

August 1966

Brief 66-10308

KSC Library

NASA TECH BRIEF



NASA Tech Briefs are issued to summarize specific innovations derived from the U. S. space program and to encourage their commercial application. Copies are available to the public from the Clearinghouse for Federal Scientific and Technical Information, Springfield, Virginia 22151.

Microphone Multiplex System Provides Multiple Outlets from Single Source

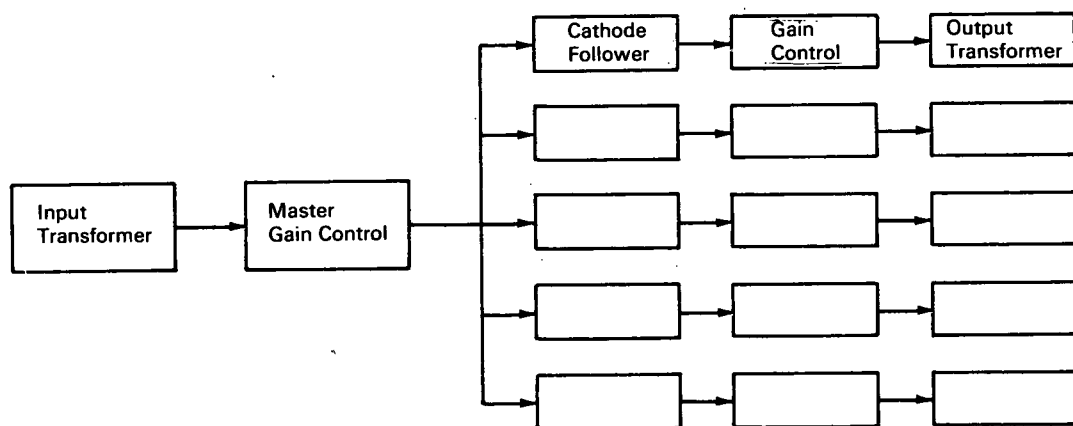

The problem:

To use a single source of audio signal to provide multiple audio outputs that can be connected to many low impedance microphone inputs simultaneously.

The solution:

A microphone multiplex system that will accept a signal from a single source (a program mixer or any 600-ohm line) and provide any number of low impedance outputs at microphone level with complete isolation between output channels.

How it's done:

The multiplexer consists of a single input transformer (600-ohm balanced or unbalanced bridge) for accepting any standard line input. The secondary of this transformer is connected to a master gain control and through isolation resistors to parallel cathode followers. The cathode followers give complete isolation between channels and connect through individual gain controls to separate output transformers. The levels of the master gain control and the

individual gain controls are adjusted so that the combined loss will be approximately 55 db at each output. Approximately 65% of this loss is taken at the individual gain controls to keep the signal-to-noise ratio and distortion at an optimum.

Notes:

1. The multiplexer meets all broadcast standards.
2. It has a response of 30 cps to 15 kc with less than 1.0% distortion at -35 db output.
3. Any input or output may be converted to high impedance by elimination of the associated transformer.
4. The input can be taken directly from a microphone with the addition of a preamplifier stage.
5. Inquiries concerning this innovation may be directed to:

Technology Utilization Officer
Goddard Space Flight Center
Greenbelt, Maryland 20771
Reference: B66-10308

(continued overleaf)

Patent status:

No patent action is contemplated by NASA.

Source: Raymond E. Lauver
(GSFC-426)