

June 1966

Brief 66-10278

# NASA TECH BRIEF



NASA Tech Briefs are issued to summarize specific innovations derived from the U. S. space program and to encourage their commercial application. Copies are available to the public from the Clearinghouse for Federal Scientific and Technical Information, Springfield, Virginia 22151.

## O-Rings with Mylar Back-Up Provide High-Pressure Cryogenic Seal

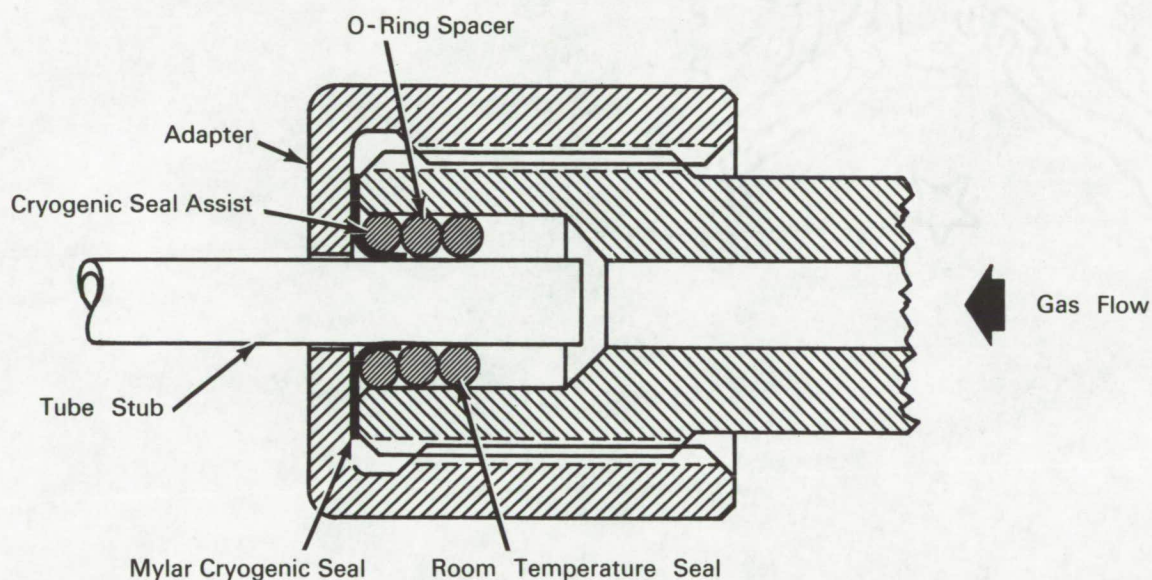

### The problem:

Sealing the junction between a tube stub and an adapter during high pressure gas flow at cryogenic to room temperatures. Leaks occur when rubber O-rings are used because they harden and shrink at cryogenic temperature.

### The solution:

A Mylar lip type back-up ring installed in combination with three rubber O-rings. Contraction pressure on the Mylar lip from one of the rings provides the low temperature seal, and the normal function of another of the seals, in conjunction with a third spacer ring, provides the ambient seal.

### How it's done:

The lip of the Mylar seal is installed on the tube stub with the disk portion resting against the end of

the adapter. The first O-ring, the cryogenic seal assist, is placed over the Mylar lip. The spacer O-ring is then placed on the tube stub adjacent to the cryogenic seal assist, and the room temperature seal O-ring is placed on the tube adjacent to the spacer.

Under cryogenic gas flow conditions, the cryogenic seal assist contracts, forcing the still resilient Mylar lip firmly against the tube for an effective seal. Axial gas pressure forces the cryogenic assist ring and the disk portion of the Mylar against the adapter end for further sealing.

Under room temperature gas flow, the ambient seal functions as a normal O-ring. The spacer prevents the room temperature seal from riding on the Mylar lip and thus losing good sealing contact with the tube stub.

(continued overleaf)

**Notes:**

1. This design provides a leakproof seal for helium flow at 1000 psig, ranging from room temperature to  $-320^{\circ}\text{F}$ .
2. Mylar seals should not be used with oxygen under pressure or in the liquid state.
3. The tube stub surface finish as it comes from stock is sufficient for effective sealing by this method.
4. Inquiries concerning this invention may be directed to:

Technology Utilization Officer  
Marshall Space Flight Center  
Huntsville, Alabama 35812  
Reference: B66-10278

**Patent status:**

Inquiries about obtaining rights for the commercial use of this invention may be made to NASA, Code GP, Washington, D.C. 20546.

Source: G. M. Funk  
of North American Aviation, Inc.  
under contract to  
Marshall Space Flight Center  
(M-FS-603)