

May 1966

Brief 66-10204

NASA TECH BRIEF



NASA Tech Briefs are issued to summarize specific innovations derived from the U. S. space program and to encourage their commercial application. Copies are available to the public from the Clearinghouse for Federal Scientific and Technical Information, Springfield, Virginia 22151.

Torque Wrench Allows Readings from Inaccessible Locations

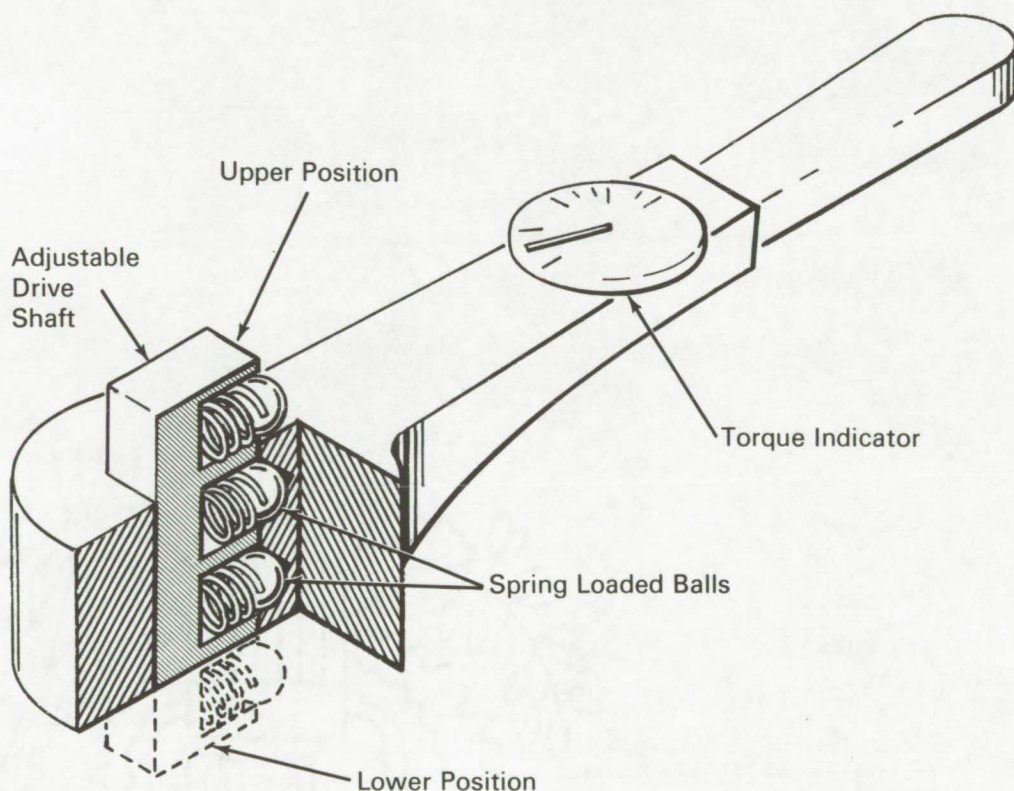

The problem:

To provide a means for viewing the indicator on a torque wrench when used on a section of equipment with limited access. When using a conventional torque wrench on the underside of a machine, for example, it is necessary for the worker either to lie on his back or use a mirror to read the indicator.

The solution:

A torque wrench with a drive shaft that can be made to protrude from either side of the wrench head would allow the torque indicator to remain in view at all times. This configuration for a torque wrench is a concept only.

(continued overleaf)

How it's done:

The torque wrench may be designed with a square shaft that can be adjusted to move out on either side of the wrench, depending on which side the socket is to be placed. The shaft has three spring-loaded balls; two are used to lock the shaft in position; the third is used to lock into the socket like a conventional wrench.

The wrench can be easily adjusted to accommodate the socket on the other side by pushing one end of the shaft into the shank. This exposes the other end and allows the socket to lock on to it.

Note:

Inquiries concerning this innovation may be directed to:

Technology Utilization Officer
Marshall Space Flight Center
Huntsville, Alabama, 35812
Reference: B66-10204

Patent status:

No patent action is contemplated by NASA:

Source: Mario DeBarnardo
of North American Aviation, Inc.
under contract to
Marshall Space Flight Center
(M-FS-598)