

April 1966

Brief 66-10149

NASA TECH BRIEF



NASA Tech Briefs are issued to summarize specific innovations derived from the U. S. space program and to encourage their commercial application. Copies are available to the public from the Clearinghouse for Federal Scientific and Technical Information, Springfield, Virginia 22151.

Depth Indicator and Stop Aid Machining to Precise Tolerances

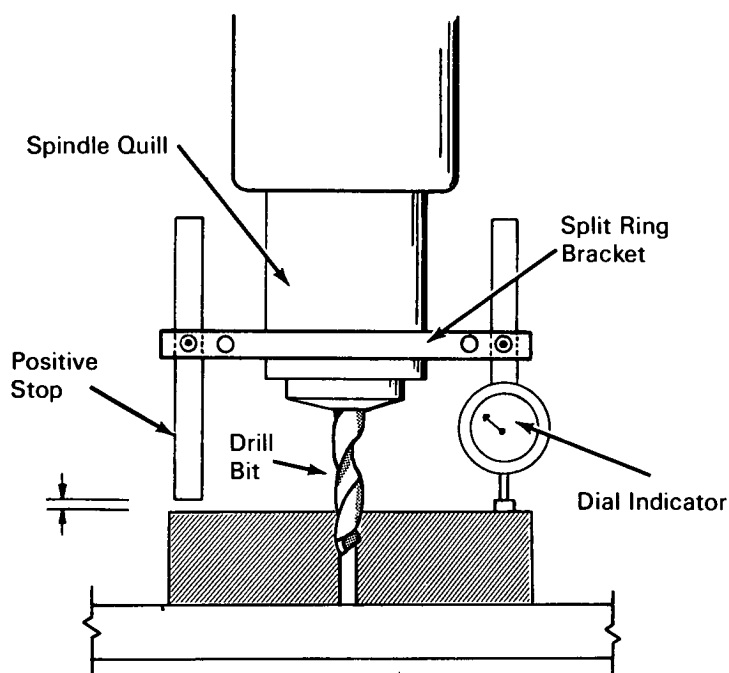

The problem:

With many drill presses, vertical milling machines, and jig borers, it is difficult to consistently hold depths of cut to close tolerances.

The solution:

An attachment that provides the machine with a visual indication of the depth of cut and also provides a positive stop to prevent overcutting.

How it's done:

The attachment consists of a split-ring bracket (shown attached to a drill-press spindle quill) that

attaches to the machine and mounts a travel dial indicator at one end and adjustable stop bar at the other. The rod holding the travel dial indicator is positioned so that the indicator will contact a reference surface. With the cutting tool mounted in the spindle, the quill and spindle are lowered until the tool reaches the precise depth of cut desired. The travel dial indicator is engaged with the reference surface and set to zero. The stop rod is then set to engage the workpiece, fixture, or press bed at the depth of cut. The tool, spindle, and quill are retracted and the workpiece put in place.

(continued overleaf)

Notes:

1. With this attachment, an operator can make repeated cuts to precise depth by observing the travel dial indicator for a zero indication.
2. Inquiries concerning this innovation may be directed to:

Technology Utilization Officer
Marshall Space Flight Center
Huntsville, Alabama, 35812
Reference: B66-10149

Patent status:

No patent action is contemplated by NASA.

Source: John L. Lavery
of North American Aviation, Inc.
under contract to
Marshall Space Flight Center
(M-FS-553)