

March 1966

Brief 66-10105

# NASA TECH BRIEF



NASA Tech Briefs are issued to summarize specific innovations derived from the U. S. space program and to encourage their commercial application. Copies are available to the public from the Clearinghouse for Federal Scientific and Technical Information, Springfield, Virginia 22151.

## Angular Acceleration Measured by Deflection in Sensing Ring

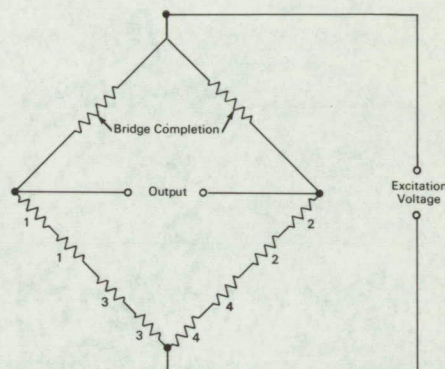
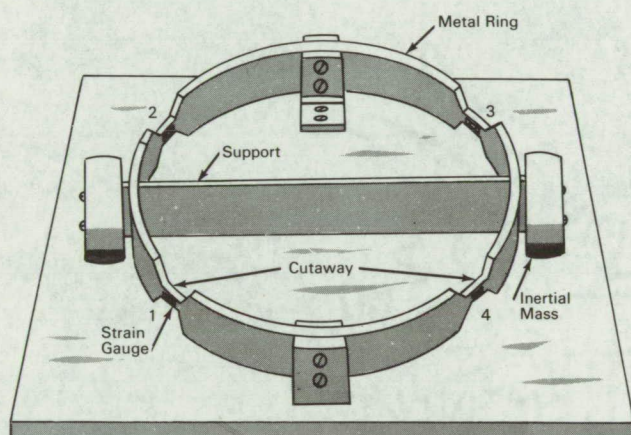

### The problem:

To design a small, lightweight angular accelerometer of simple and inexpensive construction that will perform reliably when subjected to harsh temperature and vibration environments.

### The solution:

A device that uses strain gauges to measure the amount of deflection in a metal ring caused by movement of inertial masses mounted through the ring.

### How it's done:

The sensing element consists of a metal ring to which two inertial masses are mounted and joined by a common support. The ring is cut away in four places to create strain intensification areas. Strain gauges are mounted on each side of these four areas and connected to a constantly excited wheatstone bridge circuit. Inertial force of acceleration from the two inertial masses is transmitted along the sensing ring causing

change in strain gauge current thus affecting bridge circuit output. The four inside strain gauges give greater overall sensitivity and provide cancellation of most effects not yielding angular acceleration data.

### Notes:

1. Range of the instrument is easily varied by varying the value of the inertial masses.
2. Inquiries concerning this invention may be directed to:

Technology Utilization Officer  
Manned Spacecraft Center  
Houston, Texas, 77001  
Reference: B66-10105

### Patent status:

Inquiries about obtaining rights for the commercial use of this invention may be made to NASA, Code GP, Washington, D.C., 20546.

Source: Richard Ray Richard  
(MSC-250)  
Category 01