

February 1966

Brief 66-10071

NASA TECH BRIEF



NASA Tech Briefs are issued to summarize specific innovations derived from the U. S. space program and to encourage their commercial application. Copies are available to the public from the Clearinghouse for Federal Scientific and Technical Information, Springfield, Virginia 22151.

Mechanism Isolates Load Weighing Cell During Lifting of Load

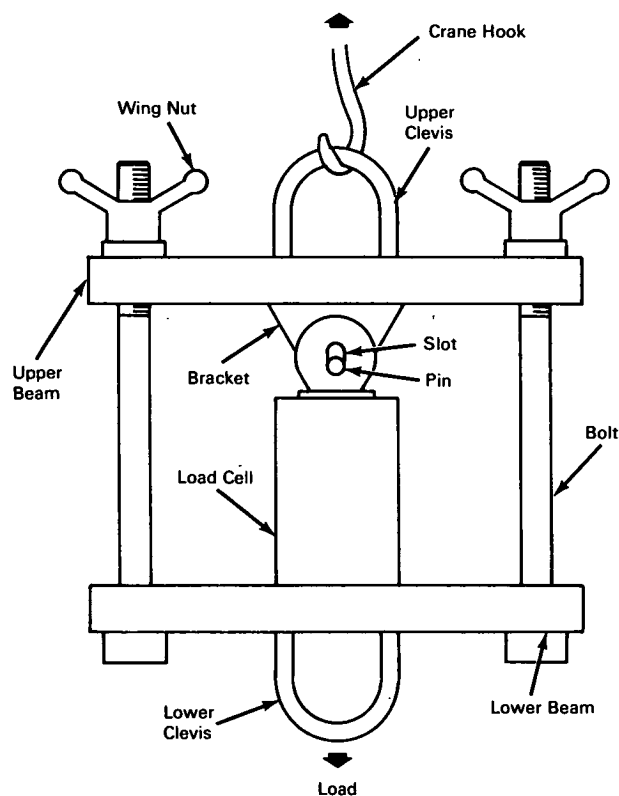

The problem:

When using a load weighing cell in conjunction with a hoist, it is desirable to isolate the cell during lifting and manipulation of the load in order to prevent application of shock and vibration forces to the cell.

The solution:

A simple mechanism, attached to a crane hook, that provides a screw adjustment for engaging the load cell during weighing of the load and isolating it

from the lift forces during hoisting or other manipulation of the load.

How it's done:

The crane hook is attached to the upper clevis, and the load is attached to the lower clevis. To engage the load cell for a weighing operation, the two wing nuts are uniformly loosened until the pin on the bracket attached to the upper beam is drawn up into contact with the top of the slot. The load cell, attached

(continued overleaf)

to the lower beam, is then freely suspended from the pin to register the weight of the load when the crane hook is pulled up. After the weight is recorded, the wing nuts are uniformly tightened until the pin is locked in contact with the bottom of the slot, as shown in the illustration. In this position, the load is fully supported by the bolts and the cell is relieved from all loading during subsequent hoisting operations.

Notes:

1. This device is in a conceptual stage only; as of the date of this Tech Brief, a model had not been constructed. In an actual model, the wing nuts would be replaced by a mechanism that would provide a sufficient mechanical advantage for engaging and disengaging the cell under load and a means for ensuring uniform tightening and loosening of the nuts.

2. Inquiries concerning this innovation may be directed to:

Technology Utilization Officer
Manned Spacecraft Center
P.O. Box 1537
Houston, Texas, 77001
Reference: B66-10071

Patent status:

No patent action is contemplated by NASA.

Source: John S. Haigler
of North American Aviation, Inc.,
under contract to
Manned Spacecraft Center
(MSC-297)