

February 1966

Brief 66-10061

# NASA TECH BRIEF



NASA Tech Briefs are issued to summarize specific innovations derived from the U. S. space program and to encourage their commercial application. Copies are available to the public from the Clearinghouse for Federal Scientific and Technical Information, Springfield, Virginia 22151.

## Instrument Quickly Transposes Ground Reference Target to Eye Level

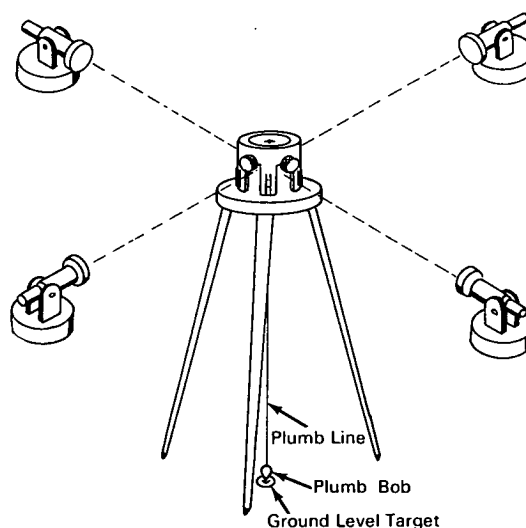
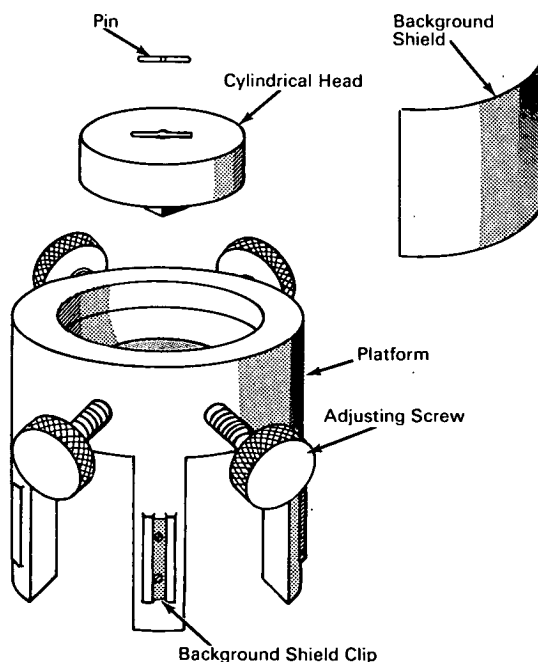

SIGHTING ON PLUMB LINE  
FROM FOUR DIRECTIONS

### The problem:

Optical alignment of equipment such as star simulators for star tracker checkout is both difficult and time consuming. Using a bore sighting instrument above a ground reference point, removing it and putting the target in place is tedious and requires a perfectly level platform, otherwise, the target is of no value.

### The solution:

A traverse target that uses a string suspending a plumb bob to transpose the ground level point to eye-level operation. The unit need not be level because

the plumb bob string will always be perfectly perpendicular.

### How it's done:

A platform provides for the lateral adjustment of a cylindrical head from which a plumb line is suspended. The head rests on a circular flange and is moved laterally by four thumb screws engaging a square protrusion on its bottom side. An aperture in the head and an opening through the center of the platform allow the plumb line, tied to a pin resting across the head aperture, to be suspended to the ground when the entire instrument is rested on its four base legs on a suitable tripod or stand.

(continued overleaf)

In use, the tripod supporting the instrument is positioned over the ground level target so that the plumb bob is approximately over the target. The four adjustment screws are then used to laterally position the head until the point of the plumb bob is exactly centered over the ground target. Leveling of the instrument is not required as the plumb string itself serves as the eye level target. The string may be sighted between the legs of the instrument from different directions. A background shield snapped into the clips on any two base legs provides for better viewing of the string.

**Notes:**

1. Normally, only 5 minutes are required to perform the total operation, an appreciable reduction in time from the present method of using a bore sighting instrument, and the same degree of precision is achieved.

2. The instrument may be used in situations where optical alignment is accomplished using a ground level reference point, and where sighting on the North Star is utilized for accurately locating a point source within optically confined areas.
3. Inquiries concerning this innovation may be directed to:

Technology Utilization Officer  
Manned Spacecraft Center  
P.O. Box 1537  
Houston, Texas, 77001  
Reference: B66-10061

**Patent status:**

No patent action is contemplated by NASA.

Source: B. E. Green and E. L. Van Deventer  
of North American Aviation, Inc.  
under contract to  
Manned Spacecraft Center  
(MSC-275)