

NASA TECH BRIEF

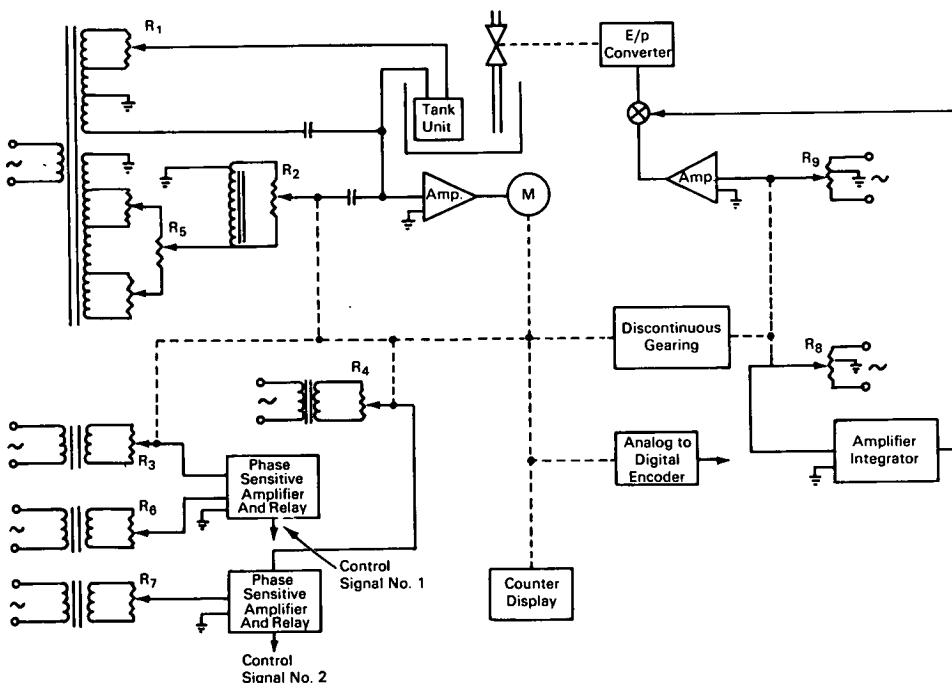

NASA Tech Briefs are issued to summarize specific innovations derived from the U. S. space program and to encourage their commercial application. Copies are available to the public from the Clearinghouse for Federal Scientific and Technical Information, Springfield, Virginia 22151.

Control System Maintains Selected Liquid Level



The problem: To provide a single-sensor control system, in which liquid hydrogen is controlled to fill a tank to a desired level, regardless of boiloff of the hydrogen. Conventional techniques employ separate sensors for each monitored level.

The solution: A single-sensor control system in which the output is calibrated in percentage. Thus, when the fuel is at a preselected desired level, the system output will indicate 100 percent regardless of what percent of tank capacity the fuel has reached. The output will be the control signal for desired level maintenance.

How it's done: A signal obtained from empty adjustment potentiometer R_1 is applied through the tank unit (liquid level sensor) to an amplifier-motor combination. Mechanical linkage from the motor extends to R_2 , R_3 , R_4 , counter display, analog-to-digital encoder, and discontinuous gearing units. Potentiometer R_5 is adjusted to select the desired tank fill level, which may range from 60 to 100 percent of the tank capacity. A correction signal applied through R_2 from R_5 combines with the signal from the tank unit, and is applied as an input to the amplifier-motor combination. The motor will operate until the signal output

(continued overleaf)

from R₂ is equal (true level) to the tank unit signal; this indicates that the fuel level in the tank has reached 100 percent of the setting of R₅. The counter display unit gives a visual percentage output indicative of the wiper position of R₂. The analog-to-digital encoder, an optional circuit item, takes the analog signal provided by the gearing and provides a digital output for computer use. Potentiometers R₃ and R₄, in conjunction with R₆ and R₇, respectively, may be set to desired levels to generate control signals from phase sensitive amplifier and relay circuits.

The discontinuous gearing unit operates when the R₂ wiper is at positions representing above 95 percent of its true level. Until R₂ reaches 95 percent of its true level, the discontinuous gearing is inoperative, keeping the wipers of R₈ and R₉ at one end of the potentiometer; no control is applied through the summing circuit and the electrical-to-pressure converter (E/P converter) which allows the valve feeding liquid hydrogen to the tank unit to remain open. When R₂ reaches 95 percent of its true value, the discontinuous gearing, acting through summing circuits and the E/P converter, starts the closing of the liquid hydrogen valve. Potentiometer R₉ is the main control over the closing

of the liquid hydrogen valve until R₂ has reached approximately 99.9 percent of its true value (representing 99.9 percent of a predetermined fill level in the tank unit). At 99.9 percent, vernier potentiometer R₈ becomes the controlling component until R₂ reaches 100 percent of its true value. Potentiometer R₈ can be adjusted for a slight overfill to allow for the natural boiling-off process of the liquid hydrogen.

Note: This gaging system would have value in controlling liquid levels in tanks, such as in the filling of commercial tank cars where the fluids frequently boil or leak away, or for use in industrial processes where the level of fluids must be constant.

Patent status: Title to this invention has been waived under the provisions of the National Aeronautics and Space Act (42 U.S.C. 2457 (f)), to Honeywell, Incorporated, 2600 Ridgway Road, Minneapolis, Minnesota, 55413.

Source: Raymond L. Bergeson and
Jack W. Schuck of
Honeywell, Incorporated
under contract to
Marshall Space Flight Center
(M-FS-470)