

January 1966

Brief 66-10002

NASA TECH BRIEF



NASA Tech Briefs are issued to summarize specific innovations derived from the U. S. space program and to encourage their commercial application. Copies are available to the public from the Clearinghouse for Federal Scientific and Technical Information, Springfield, Virginia 22151.

Dual-Voltage Power Supply Has Increased Efficiency

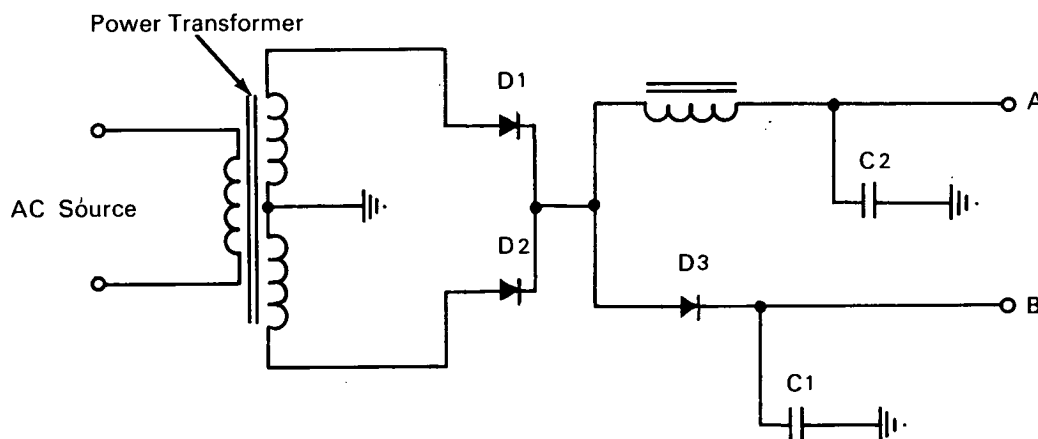

The problem: To design an efficient circuit that will provide two different dc output voltages from an ac source. Conventional circuits require either a precisely tapped transformer with a separate rectifier and filter for each voltage output, or dropping resistors, which waste power and result in poor regulation.

The solution: A simple circuit employing a full-wave rectifier connected to two passive branches from which the separate dc voltages are taken.

How it's done: The primary winding of the power transformer is connected to the ac source, and the secondary winding is connected to the full-wave rectifier consisting of diodes D1 and D2. The unfiltered output from the full-wave rectifier is fed in parallel to a conventional choke-input filter branch and a diode-capacitor branch. The diode, D3, in this branch conducts on the peaks of the full-wave rectifier current and charges capacitor C1 to the peak voltage across

one half of the secondary winding of the power transformer. The voltage at terminal A will be approximately 40% greater than at terminal B. The required peak inverse-voltage rating of diode D3 is only one-half the peak voltage across the full secondary winding of the transformer.

Notes:

1. For maximum voltage output at terminal A, a high-conductance semiconductor diode should be used in the branch.
2. The ratio of the output voltages may be varied by proper choice of component values.
3. The outputs have low ripple and good voltage regulation.
4. This circuit can be used in lieu of relatively complex and expensive voltage regulators to supply dual voltages in applications not requiring precise voltage regulation.

(continued overleaf)

5. Inquiries concerning this invention may be directed to:

Technology Utilization Officer
Lewis Research Center
21000 Brookpark Road
Cleveland, Ohio, 44135
Reference: B66-10002

Patent status: NASA encourages the commercial use of this invention. It was invented by a NASA employee, and U.S. Patent No. 3,053,991 has been issued to him. Inquiries about obtaining license rights for its commercial development should be addressed to the inventor, Mr. John C. Sturman, NASA, Lewis Research Center, 21000 Brookpark Road, Cleveland, Ohio, 44135

Source: (Lewis-107A)