

December 1965

Brief 65-10388

NASA TECH BRIEF



NASA Tech Briefs are issued by the Technology Utilization Division to summarize specific technical innovations derived from the space program. Copies are available to the public from the Clearinghouse for Federal Scientific and Technical Information, Springfield, Virginia, 22151.

Strainer Fits Inside Flared-Tube Fittings

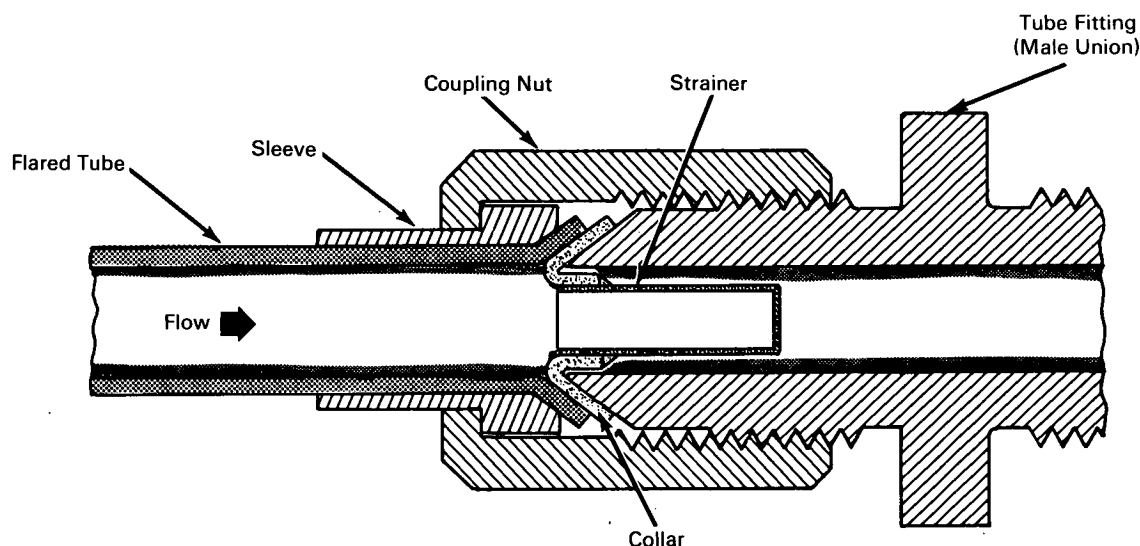

The problem: To provide a simple, easily replaceable strainer that can be readily installed in standard flared-tube fittings.

The solution: A cylindrical wire-mesh strainer with a collar that seats on the tapered shoulder of the male fitting.

How it's done: The strainer is inserted into the bore of the tube fitting so that the collar seats on the tapered shoulder at the upstream end of the fitting. When the coupling nut is tightened, the strainer is held firmly in place and a leakproof seal is formed at the junction surfaces.

Notes:

1. This strainer can be readily installed in existing plumbing systems that use flared-tube fittings.

2. Inquiries concerning this invention may be directed to:

Technology Utilization Officer
Langley Research Center
Langley Station
Hampton, Virginia, 23365
Reference: B65-10388

Patent status: NASA encourages the immediate commercial use of this invention. It is owned by NASA and inquiries about obtaining royalty-free rights for its commercial use may be made to NASA, Code AGP, Washington, D.C., 20546.

Source: Otis J. Parker
(Langley-180)

Category 05