

September 1965

Brief 65-10266

# NASA TECH BRIEF



NASA Tech Briefs are issued by the Technology Utilization Division to summarize specific technical innovations derived from the space program. Copies are available to the public from the Clearinghouse for Federal Scientific and Technical Information, Springfield, Virginia, 22151.

## One-Shot Valve May Be Remotely Actuated

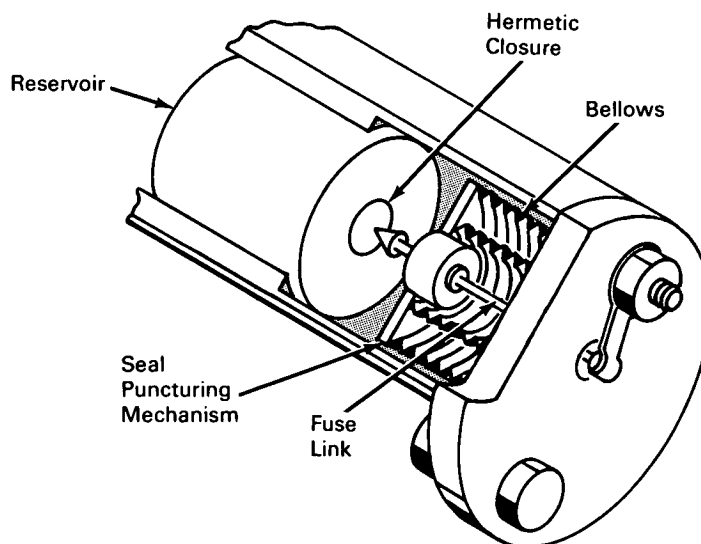

**The problem:** To provide a hermetically sealed closure with an emergency release that can be actuated by a remote sensor.

**The solution:** A one-shot valve that contains a spring-loaded plunger and sealing diaphragm. The plunger is released by the electrical melting of a fuse link and pierces the valve seal.

**How it's done:** The bellows is held in a constrained position by the plunger and fuse link. An electric current is passed through the fuse link causing it to melt, thus releasing the compressed bellows which then drives the plunger through the hermetic closure. The bellows acts as a dynamic seal so that the unit remains hermetically sealed after actuation.

### Notes:

1. This innovation could be used to lower fluid pressure in a container without losing the contained fluid.

2. This valve is a one-shot device and must be replaced after use.
3. Inquiries concerning this innovation may be directed to:

Technology Utilization Officer  
Western Operations Office  
150 Pico Boulevard  
Santa Monica, California, 90406  
Reference: B65-10266

**Patent status:** NASA encourages commercial use of this innovation. No patent action is contemplated by NASA.

Source: S. Kami of  
Hughes Aircraft Company  
under contract to  
Western Operations Office  
(WOO-195)  
Category 05