

August 1965

Brief 65-10244

NASA TECH BRIEF



NASA Tech Briefs are issued by the Technology Utilization Division to summarize specific technical innovations derived from the space program. Copies are available to the public from the Clearinghouse for Federal Scientific and Technical Information, Springfield, Virginia, 22151.

Lightweight Coaxial Cable Connector Reduces Signal Loss

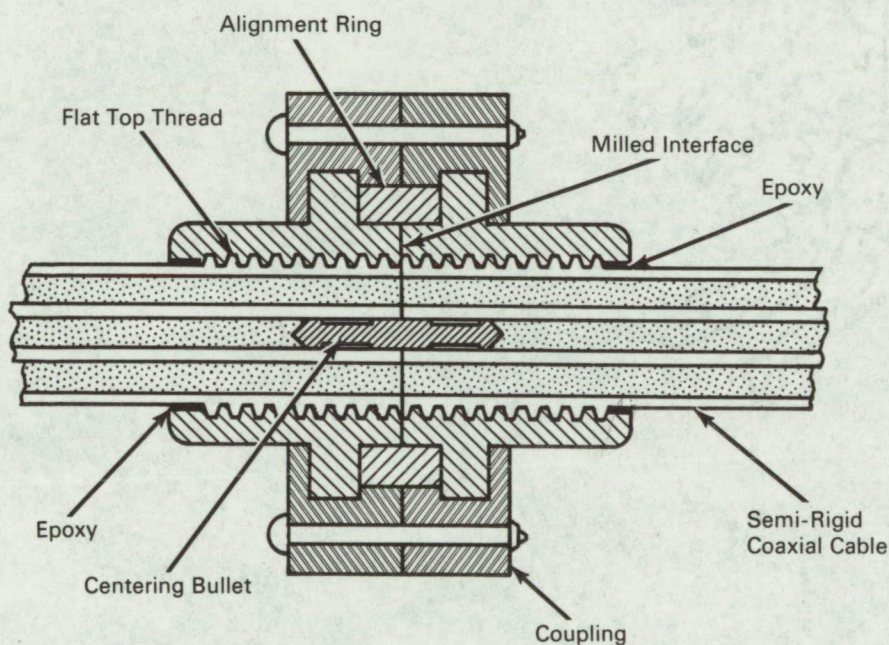

The problem: To design a connector, for flexible, semirigid, and rigid rf coaxial cables, that eliminates the possibility of secondary-emission discharge and provides low signal loss, low VSWR, lightweight construction, and good protection of the cable ends.

The solution: A connector with milled interface surfaces that provide near perfect electrical contact, plus alignment and centering components to assure proper joint concentricity.

How it's done: The milled interface ensures an almost perfectly smooth electrical contact, free of discontinuities and high or low spots. Because there is

essentially no air gap, the contact is free of secondary-emission discharge, which, if sufficiently high, can result in short circuit and breakdown of the cable. The modified threads engaging the outer conductor provide a gap between conductor and connector body for sealing and locking the threads with an epoxy. Precisely concentric alignment of the inner conductor is assured by a centering bullet, and of the outer conductor by a precision alignment ring. A standard, flanged coupling holds the connector together.

Notes:

1. This invention should be of interest to designers of communications systems.

(continued overleaf)

2. Inquiries concerning this invention may be directed to:

Technology Utilization Officer
Jet Propulsion Laboratory
4800 Oak Grove Drive
Pasadena, California, 91103
Reference: B65-10244

Patent status: NASA encourages the immediate commercial use of this invention. Inquiries about obtaining rights for its commercial use may be made to NASA, Code AGP, Washington, D.C., 20546.

Source: Albert G. Brejcha, Jr.
(JPL-720)