

June 1965

Brief 65-10198

NASA TECH BRIEF



NASA Tech Briefs are issued by the Technology Utilization Division to summarize specific technical innovations derived from the space program. Copies are available to the public from the Clearinghouse for Federal Scientific and Technical Information, Springfield, Virginia, 22151.

Self-Aligning Fixture Used in Lathe Chuck Jaw Refacing

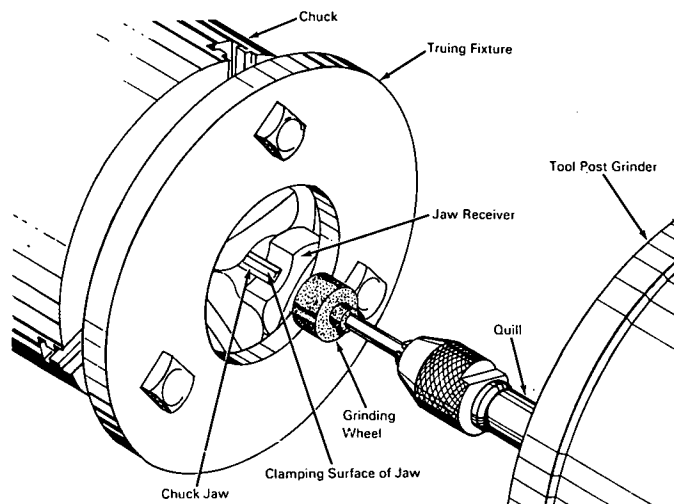

The problem: To properly position and rigidly hold lathe chuck jaws for refacing and truing of the clamping surfaces. The ideal method would have the jaws clamp a holding fixture during refacing in the same manner a workpiece is held. Fixtures used previously either did not hold the jaws accurately or could not be used on different size chucks.

The solution: A self-aligning fixture that positions the chuck jaws accurately as they clamp it in the manner of clamping a workpiece. The fixture can be used on a range of chuck sizes.

How it's done: Chuck jaw receivers are bolted to a ring in a free-pivoting mode. The receivers have tapered walls that slip over and mate with the tapered sides of the chuck jaws. The tapered walls are slightly cut out at their apex so that the chuck jaws, in the engaged position, protrude slightly to present their clamping surfaces to the truing and refacing tool. The chuck jaws are closed to come into firm bearing contact with the receivers thus accomplishing a rigid, true positioning as in the normal clamping of a workpiece.

The conventional tool post grinder is then used to true and reface the chuck jaw clamping surfaces.

Notes:

1. This design may be readily modified to accommodate 4-jawed checks, which, though less susceptible to out-of-true wear because of their adjustable centering feature, do suffer wear and looseness over long usage.
2. Inquiries concerning this innovation may be directed to:

Technology Utilization Officer
Flight Research Center
P.O. Box 273
Edwards, California, 93523
Reference: B65-10198

Patent status: NASA encourages the immediate commercial use of this innovation. No patent action is contemplated.

Source: Charles C. Linn
(FRC-21)
Category No. 05