

June 1965

Brief 65-10174

# NASA TECH BRIEF



NASA Tech Briefs are issued by the Technology Utilization Division to summarize specific technical innovations derived from the space program. Copies are available to the public from the Clearinghouse for Federal Scientific and Technical Information, Springfield, Virginia, 22151.

## Pressure Transducer System Is Force-Balanced, Has Digital Output

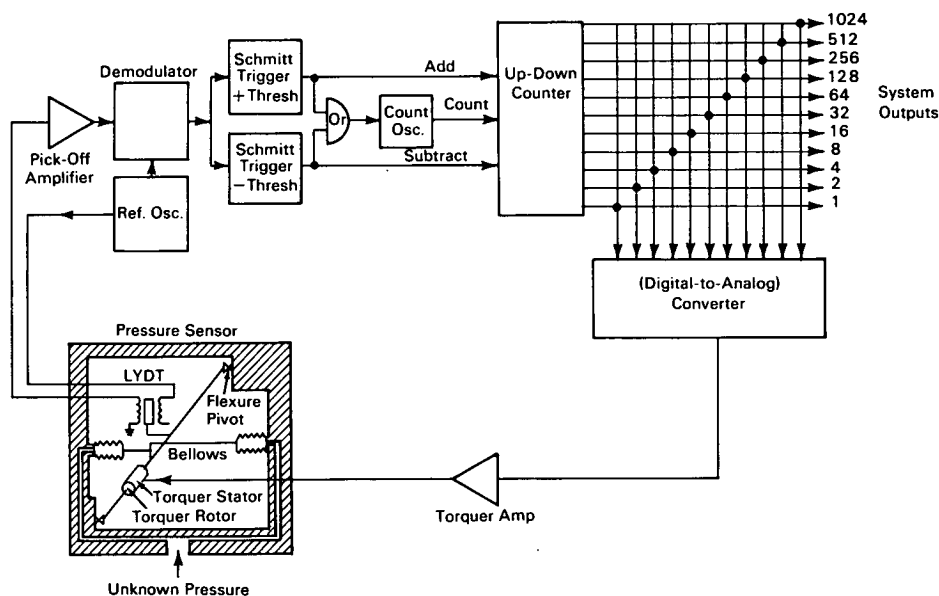

**The problem:** Much pressure testing of space equipment systems under actual operating conditions must be controlled and recorded remotely. Present methods use an analog-to-digital conversion from pre-calibrated sensors. For increased accuracy, a balancing device with associated circuitry that would automatically convert the sensed condition to digital form was desired.

**The solution:** A force-balanced pressure transducer and associated circuitry that automatically converts the sensed pressure to a digital output as a pure parallel binary number.

**How it's done:** The input pressure is routed to a pair of bellows that convert it to a net force. This force acts on a rotatable assembly to produce a torque that moves the assembly minutely in its flexure pivot mounts. Displacement of the assembly is sensed by a

linear variable differential transformer (LVDT) that detects both the direction and amplitude of the movement. The signal from the LVDT is amplified, phase detected, shaped, and fed to a counter. The counter will count up or down (add or subtract) any signal above a selected amplitude in accordance with its phase. Output of the counter is a pure parallel binary counter.

From the counter output, a balance circuit is operated through a digital-to-analog converter that produces voltage increments in accordance with the binary code. The sum of these increments is an analog voltage proportional to the system digital output. The voltage is converted to a current and fed to a d-c torquer that is an integral part of the rotatable assembly. The coils of the torquer are so arranged that a torque is produced to oppose that produced by the

input pressure. This opposing torque serves to rebalance the rotatable assembly so that the pickup output (or error signal) remains at a null. Actual motion in the rotatable assembly is limited to a fraction of an arc minute and the transducer approaches the ideal "no moving-part" system. The device is a closed loop in that it will continue to operate until the sum of the moments about the rotatable assembly is zero, that is, the input displacement has been cancelled.

**Note:** Inquiries concerning this invention may be directed to:

Technology Utilization Officer  
Marshall Space Flight Center  
Huntsville, Alabama, 35812  
Reference: B65-10174

**Patent status:** NASA encourages the immediate commercial use of this invention. Inquiries about obtaining rights for its commercial use may be made to NASA, Code AGP, Washington, D.C., 20546.

Source: Giannini Controls Corporation  
under contract to  
Marshall Space Flight Center  
(M-FS-154)