

January 1965.

Brief 65-10013

NASA TECH BRIEF



NASA Tech Briefs are issued by the Technology Utilization Division to summarize specific technical innovations derived from the space program. Copies are available to the public from the Clearinghouse for Federal Scientific and Technical Information, Springfield, Virginia, 22151.

Zener Diode Function Generator Requires No External Reference Voltage

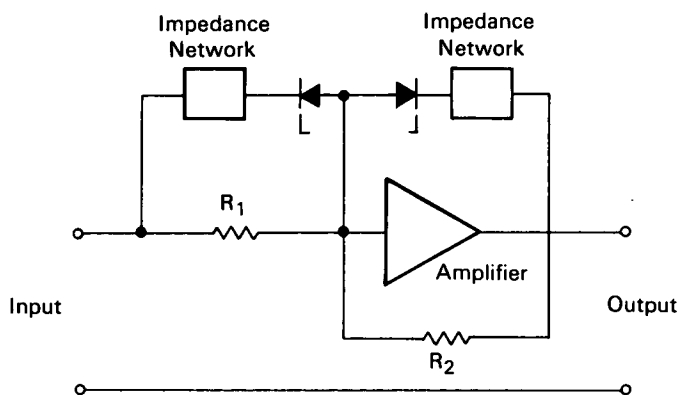

FIGURE 1

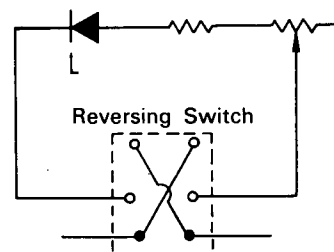

FIGURE 2

The problem: For many applications, an electronic differential analyzer requires a function generator that can produce functions discontinuous in slope as well as smooth monotonic and polytonic continuous functions. Diode function generators previously used alone or with smoothing oscillators require external voltage references and are subject to drift due to reference voltage drift as well as to temperature variations in the diodes.

The solution: A function generator using zener diodes is reasonably stable with temperature variations and requires no external reference voltage. The generator provides a wide variety of breakpoints and features repeatable operation with a minimum of recalibration required.

How it's done: The general layout of the zener diode function generator is shown in figure 1. An input signal is fed into R_1 which is connected in

parallel with an impedance network and a zener diode. In series with these circuit elements is another parallel network consisting of a zener diode, a second impedance network, a high-gain dc amplifier, and a resistance R_2 . The function generated appears at the output of this parallel network in the form of a voltage varying in time. The nature of this function depends on the two impedance networks. The network may consist of one or more basic cells of the type shown in figure 2, connected in parallel. The basic cell has a reversing switch for effecting an interchange of the external connections, a zener diode, a resistor, and potentiometer, all connected in parallel. The diode is selected for its zener voltage which determines the point in the generated function at which there is an abrupt change in the slope. This voltage is the point at which the resistance in the back direction is very low. Diodes are commercially available covering a wide range of zener voltage so that a great variety of functions may be generated with the proper selection of diodes.

(continued overleaf)

Note: Inquiries concerning this invention may be directed to:

Technology Utilization Officer
Jet Propulsion Laboratory
4800 Oak Grove Drive
Pasadena, California, 91103
Reference: B65-10013

Patent status: NASA encourages the immediate commercial use of this invention. Inquiries about obtaining rights for its commercial use may be made to NASA, Code AGP, Washington, D.C., 20546.

Source: George Bolte and
Robert Burns
(JPL-0031)