

N64-30342

COMMUNICATIONS SATELLITE TECHNOLOGY

ALBERT L. HEDRICH

Communications Consultant
Spacecraft Systems and Projects Division
NASA Goddard Space Flight Center

One of the first applications of Earth-orbiting satellites considered was for intercontinental communications. Neither of the other means available—cables and high-frequency radio—completely meets the current requirements of intercontinental communications. A modern system must be capable of furnishing real-time contact between any two points on the Earth whenever the user or customer wants it. It must be reliable and it must be flexible. Cables are reliable but have fixed end points and, therefore, lack flexibility and require a high density of traffic between these points to justify their installation. High-frequency radio, on the other hand, has the requisite flexibility and can provide communication between any two points having the necessary local fixed equipment; but it leaves much to be desired in reliability. It depends on the ionosphere acting as a reflector to direct the signals over the horizon, and the user is left at the mercy of a highly variable transmission path.

Earth-orbiting satellites have, potentially at least, the answers to the shortcomings of both cables and high-frequency radio while still meeting the other requirements of intercontinental communications. Frequencies high enough to be independent of the ionosphere can be used to provide the high reliability without sacrificing the flexibility of high-frequency radio.

There were, however, a number of problems to be solved before such a system could be considered practical from an operations viewpoint. A communications satellite system has been compared with a microwave relay system, and the similarities have been stressed. From the engineer's viewpoint, however, the differences are much more substantial. The distance between transmitter and receiver is much great-

er; the repeater must operate in an environment quite different from that on the Earth's surface, one that even now is not completely defined; the power available at the repeater is severely limited; the entire package must survive launching and then operate for a long period without servicing or attention of any kind. These were very serious problems when the communications satellite program was undertaken in NASA. The story of their solutions and the development of the technology to the point where it can be turned over to the industry for use in routine communications service is interesting and one in which all of the scientific community who took part can take pride.

COMMUNICATIONS SATELLITE SYSTEMS

A communications satellite cannot be considered apart from the system in which it operates. The design of the satellite must consider the nature of the signals that will pass through it. The location, movement, and power output of the satellite determine the specifications for a suitable ground station to operate with it. It is not surprising, therefore, to find that development of ground-station technology has proceeded concurrently with the development of the satellite.

Before considering specific communications satellites, it is useful to examine the overall system to see how the satellite imposes certain constraints on the other system components and how these constraints affect the application of the system.

Two basic types of systems are shown in figure 1. The passive satellite serves to reflect or scatter the signal beamed at it from the transmitting ground station. In this respect its function is the same as that of the ionosphere in the high-frequency radio sys-

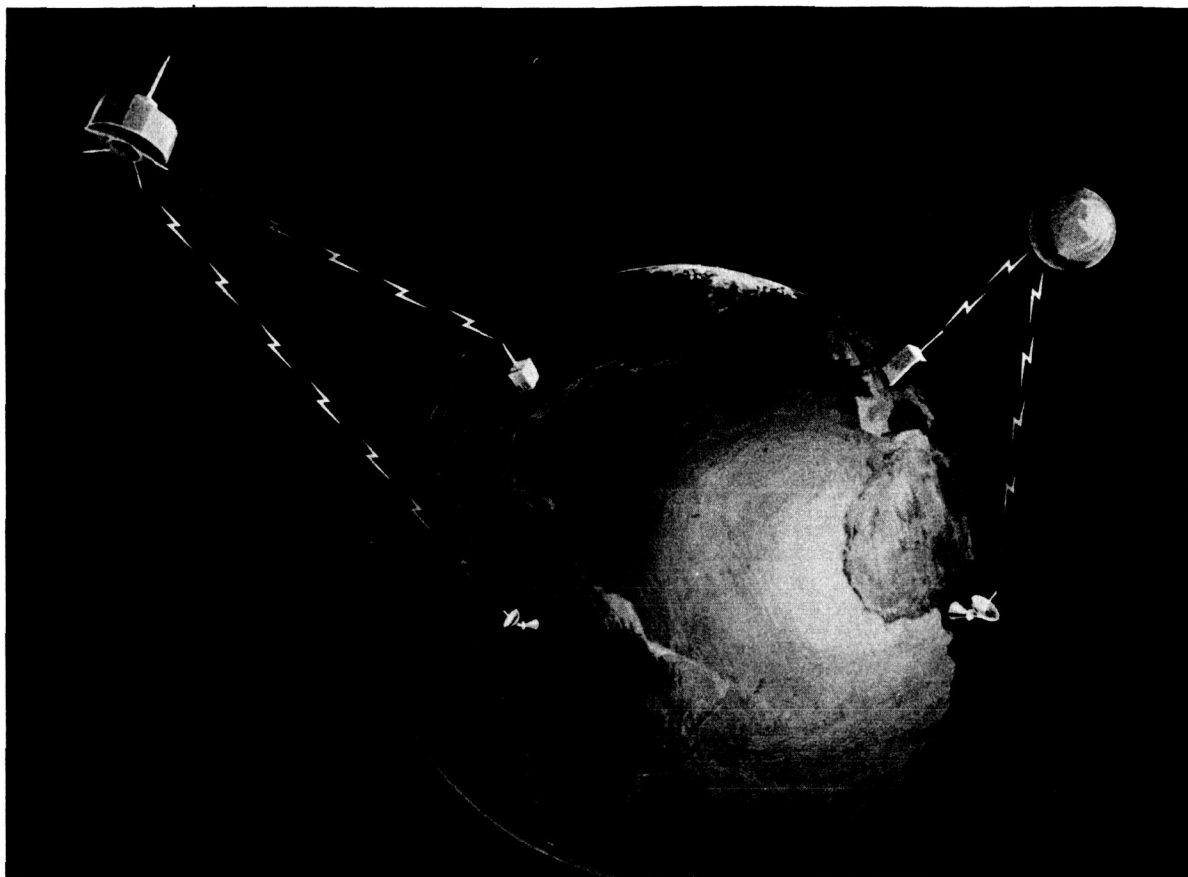

FIGURE 1.—Communications via active repeater and passive satellites.

tems. The passive satellite, however, is much more predictable than the ionosphere and, therefore, can provide a more reliable communication link. Any receiving station that can "see" the satellite can function as the other end of the link. Since the satellite will reflect signals of any frequency in essentially the same way, any two stations operating on the same frequency can communicate via the satellite without regard to any other stations using it. The only requirement is that each transmitting station operate on a different frequency. The absence of any signal amplification in the satellite results in a very low power level present at the receiver. This limits the maximum altitude at which passive satellites can be used which, in turn, limits the area on the Earth's surface from which the satellite can be seen. Thus, a large number of satellites would be required in an operational system. The high attenuation suffered by the signal means that a high power must be transmit-

ted if the system is to have a useful capacity. The effect is to transfer complexity from the satellite to the ground station. One of the most important implications of the satellite simplicity is the long satellite lifetime in orbit that can be expected. The advantages of the passive system are its potentially long lifetime, high reliability due to its simplicity, and the fact that it can be used by any number of pairs of ground stations simultaneously without interference as long as no two transmitting stations use the same frequency. The advantages appear at the present time to be more than outweighed by the disadvantages if commercial use is considered. The primary disadvantage is the requirement of complex and, therefore, expensive ground stations for even a limited traffic capacity. The development of larger satellites in the future may make them attractive in some kinds of service.

The other system shown in figure 1 is the active

communications satellite system. This system differs from the passive system in that the satellite, after receiving the signal from the transmitting ground station, amplifies it and retransmits it at a much higher power level. This feature allows much simpler ground stations to be used for a given traffic handling capability than is necessary with a passive system. It also requires a much more complicated satellite than the balloon of the passive system, and it can be used simultaneously by only a limited number of ground stations. Since there is a much higher power level on the down link than there is with a passive system, the satellite can be placed at a much higher altitude and can, therefore, provide wider geographical coverage.

Having briefly described the two main classes of communications satellites in a general way, let us now consider the present state of the technology.

REVIEW OF PRESENT TECHNOLOGY

Passive Satellites

On August 12, 1960, the first passive communications satellite, Echo I, was launched by NASA. Almost 4 years later it is still orbiting the Earth and is being used in communications experiments. It was originally in the shape of a sphere with a diameter of 100 feet and was made of Mylar film which was made reflective by a very thin layer of evaporated aluminum. The effects of solar pressure and the tendency of the material to refold after internal pressure was lost has caused it to lose its spherical shape and greatly reduced its effectiveness as a communications device.

Echo II was launched in January of this year and represents an improvement over Echo I in size and rigidity. Echo II is 135 feet in diameter; this results in a twofold increase in signal level at the receiving station, all other factors being constant. It is constructed of a material made by laminating two thin sheets of aluminum on each side of a Mylar sheet. When this material is stressed sufficiently, it is smoothed out and loses its tendency to refold. It then is rigid enough to resist the force of solar pressure which would deform it. It can, therefore, be expected to remain useful as a communications satellite much longer than did Echo I. Figure 2 shows one of the test spheres inflated in a hangar at Lakehurst, N.J., prior to the launch. Techniques for handling large structures of this type and for making quantitative measurements of the surface characteristics, both

optically and electromagnetically, were developed. The development of the Echo II satellite has resulted in the development of materials, processes, and techniques with potential applications in other than communications satellite technology. It makes available techniques for erecting large structures in space, such as directive antennas and large solar collectors. Means for controlling the inflation of such structures by the use of subliming solids were demonstrated. A television system was carried in the Agena vehicle and was used to view the deployment and inflation in space of the Echo II sphere in real time.

The versatility of the passive system is dramatically demonstrated by Echo II. The U.S. Air Force is conducting experiments with Echo II using their facilities at Rome, N.Y., Trinidad, and Ohio State University. The U.S. Navy and NASA are engaged in a cooperative program, using facilities of the Naval Research Laboratory at Stump Neck, Md.; the Naval Electronics Laboratory at San Diego, Calif.; and the Collins Radio Co. at Dallas, Tex. The United Kingdom and the U.S.S.R. have conducted experiments between the Jodrell Bank Observatory in England and the Zimenki Observatory at Gorkiy, Russia. The U.S. Coast and Geodetic Survey has indicated an interest in using it in survey work. All of this has been done without the necessity of scheduling the availability of the satellite to those who desire to use it. NASA has freely supplied orbital information to any who desire it to allow them to track the satellite.

Echo I and Echo II have also provided visible evidence to the entire world of our ability to orbit manmade satellites. This can be expected to spark the imagination of young people particularly and create an interest in the space program.

Active Satellites

Active communications satellite technology has advanced to the point where a corporation has been chartered to establish and operate a system utilizing satellites for international communications. The technology has been demonstrated by the successful launching by NASA and experimental use of five active communications satellites. On July 10, 1962, NASA launched the first Telstar satellite for AT & T. This was followed on December 13, 1962, by the launching of Relay I, which is still operating and is being used in experiments and demonstrations between the United States and Europe, South America,

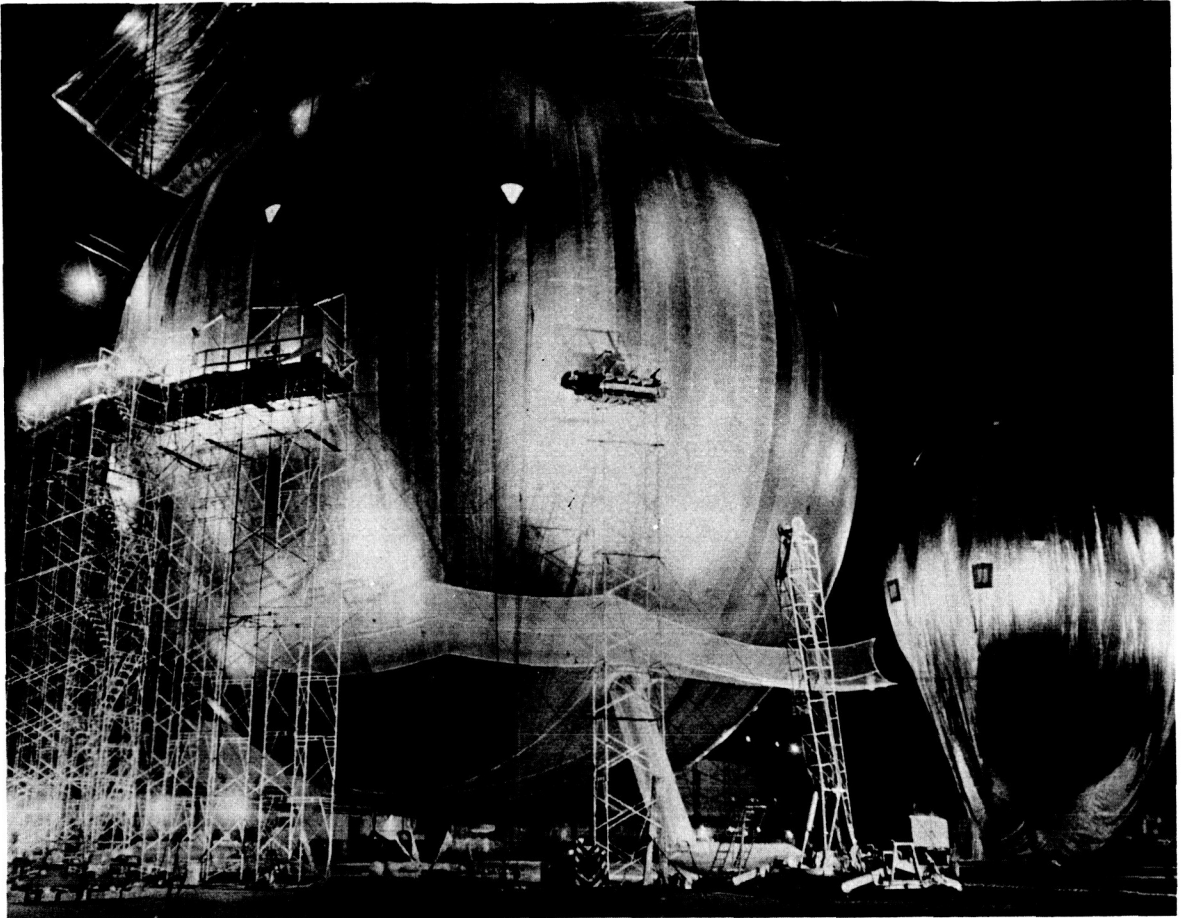

FIGURE 2.—Echo II test sphere.

and Japan. 1963 saw the successful launching of the second Telstar and Syncom. In January of this year the second Relay satellite was launched. Of these five satellites, all but the first Telstar are still operating and furnishing valuable information for future planning and satellite design.

The most difficult problem facing the designers of the first active communications satellites was how to make a satellite with a lifetime of at least 1 year in orbit. A lifetime of 1 year was chosen as a goal not because this would provide an economical system but because, considering the state of the art at the time and past experience, this seemed to be almost impossible. However, subsequent experience has shown even longer lifetimes to be feasible at the present time.

The only part of the spacecraft with an inherently short life is the power-supply system. All other subsystems could be expected to survive for a very long

time in space, barring any unexpected severe environmental conditions in space, if they survived the rigors of the launch. The knowledge of the space environment was based on somewhat scattered data points and involved some extrapolation to get to the conditions to be expected. A high-altitude nuclear test a short time prior to the launching of the first Telstar resulted in an enhanced radiation field through which the satellite traveled. This is thought to have contributed significantly to the premature failure of the command system of this spacecraft and has increased the rate of degradation of the solar cells used to supply power to subsequent satellites in the medium-altitude range.

This first Relay satellite was launched by NASA on December 13, 1962. The satellite is shown in figure 3. Characteristics of the orbit and the satellite are shown in table I.



FIGURE 3.—The first Relay satellite.

TABLE I.—Relay I orbit and satellite data.

Spacecraft weight.....	172 pounds
Height of apogee (approx.).....	4,000 nautical miles
Height of perigee (approx.).....	700 nautical miles
Inclination.....	47.52 degrees
Stabilization.....	Spin
Communications frequencies:	
Up link.....	1,725 Mc
Down link.....	4,170 Mc
Modulation.....	FM on both up and down links

Figure 4 shows the Relay satellite in orbit. Relay I is spin-stabilized with the spin axis in the plane of the orbit. The antenna pattern, shown in figure 4, is a figure of revolution about the spin axis. The satellite is useful for communications use only when in the orientation with respect to the Earth as shown. Twice in each orbit one end of the satellite is pointed toward the Earth, and the Earth is in a null

of the antenna. In this orientation the satellite is not used. The orbit has an apogee of approximately 4,000 nautical miles and a perigee of approximately 700 nautical miles. This orbit was chosen because it provided mutual visibility times between North America and Europe of up to about 50 minutes when apogee occurred over the North Atlantic. This was important to allow meaningful experiments and convincing demonstrations to be performed between the AT & T. ground station at Andover, Maine, and the British and French stations at Goonhilly and Plemeur Bodou, respectively. In addition to communications between these large stations, smaller stations in the United States, South America, Italy, and Japan successfully communicated via Relay. The ground stations that participated in the Relay experiment are shown in figure 5.

A significant part of the project staff's efforts has been devoted to scheduling the use of Relay I by the large number of ground stations desiring to use it. The procedures that have been developed are considered to be a major contribution of the project to communications satellite technology.

The central point of the Relay system is the operations control office at Goddard Space Flight Center, Greenbelt, Md. This office, designated COMSOC for Communication Satellite Operations Center, is used to direct all command and control of the satellite, evaluation of real-time data, and as the office through which all communications experiment scheduling and coordination is conducted. COMSOC issues all operation plans and experiment schedules and acts as a clearing-house for orbital predictions and correlated data.

The Relay satellites are operated daily. Because of the size limitations on the power supply and since the wideband subsystem represents a severe electrical load, it is necessary to exercise precise control in order to realize maximum utilization of available power. This can only be effected through the means of reliable command capability and real-time telemetry data readout. The spacecraft is controlled by COMSOC, utilizing the test station (COMCON) to provide the command and telemetry function at the direction of COMSOC. These functions are critical because of the necessity for turning on the spacecraft at a pre-scheduled time in order that one or more communication stations can conduct experiments. The actual control of the satellite is performed by the COMSOC-COMCON combination with direction being supplied by COMSOC.

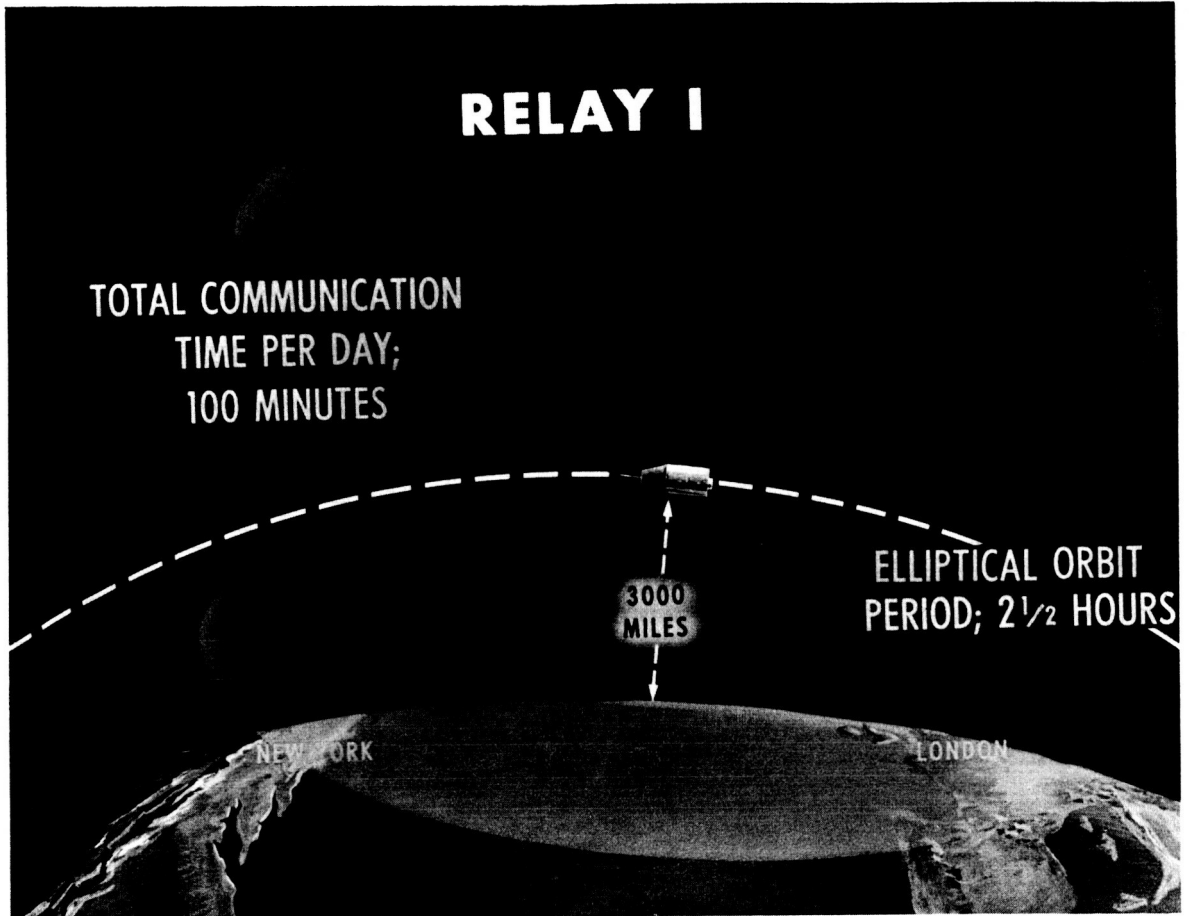

FIGURE 4.—Relay I in orbit.

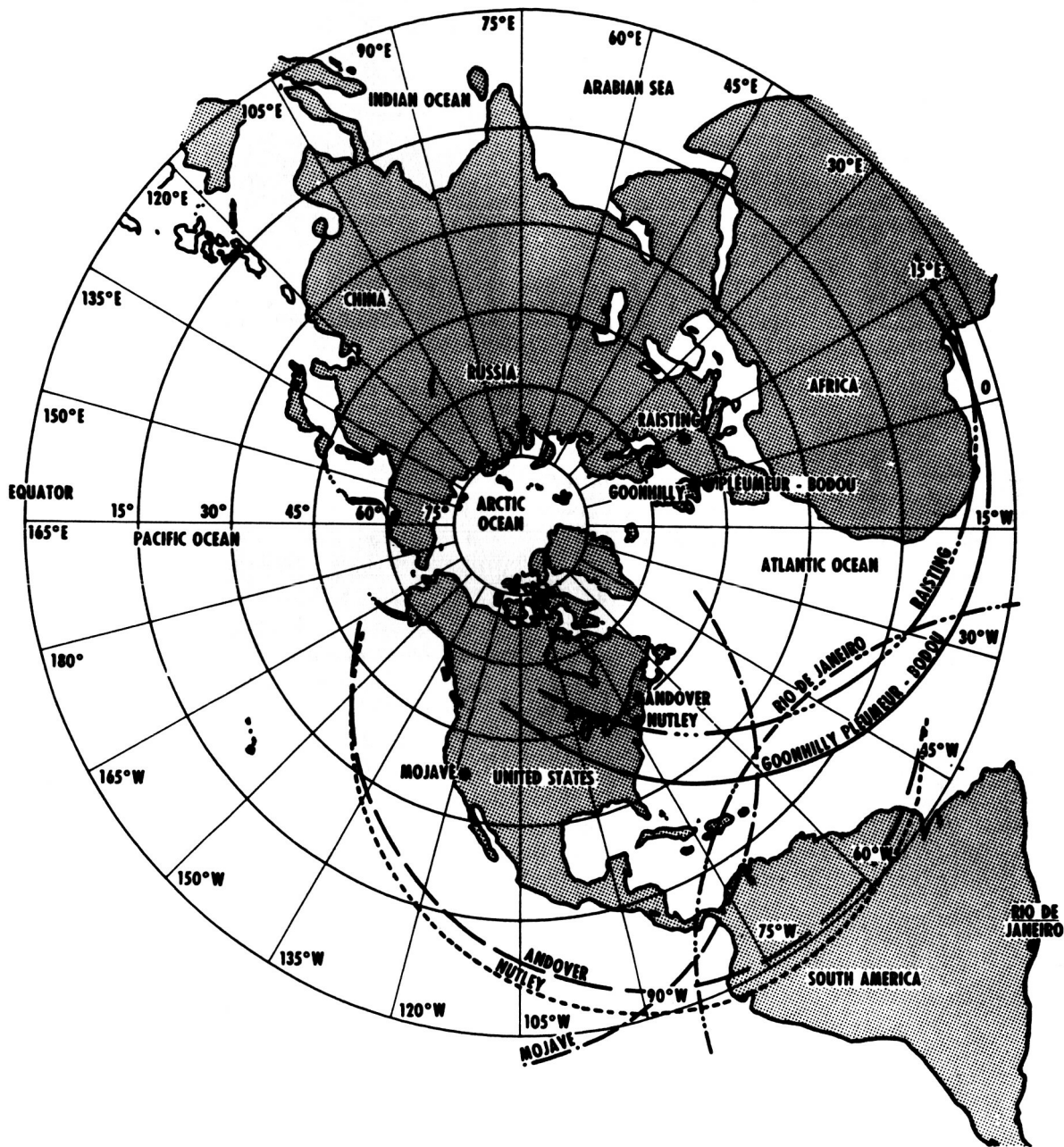

FIGURE 5.—Relay ground station and test station location. Circles show points on the Earth beneath the satellite at 2,000-mile altitude at an elevation angle of 5° from each ground station.

Controlling the experimentation on Relay is a continuous problem because each station has a diversified capability unique to itself. In addition, the variety of communications experiments to be conducted are complex. They require coordination so that the stations participating are assured of adequate test setup time. Of course, one aspect not to be neglected is that Relay has the capability of supporting public demonstrations of television, teletype, facsimile, and telephony. To make certain that these demonstrations are started at the precise time that the transponder is available, COMSOC has been used to cue the program network. Many of the requirements of the Relay system are the result of the experimental nature of the program. Some of the requirements, however, are common to both experimental and operational systems. Therefore, the experience gained with the Relay satellites should be of value in establishing an operational system.

Control of the spacecraft is exercised from either of the stations at Nutley, N.J. (fig. 6), or Mojave, Calif., under direction from the Goddard Space Flight Center; and it is necessary for them to determine the spacecraft condition at the beginning of each pass during which it is to be used before releasing it for an experiment or a demonstration. This prevents possible damage to the spacecraft which could be caused by operating it in certain conditions. It also serves to insure that experiments will be meaningful and that the user will not be embarrassed by using the spacecraft in a demonstration when it is in a substandard condition.

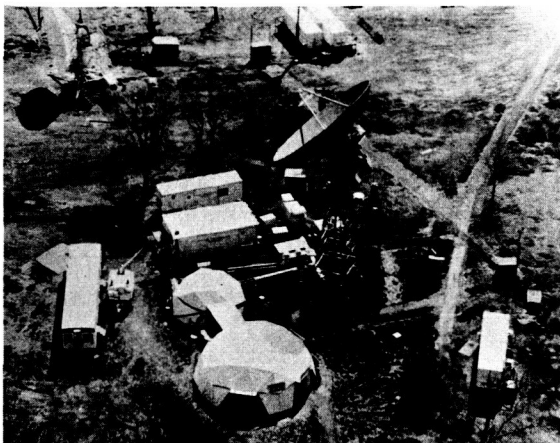

FIGURE 6.—Station at Nutley, New Jersey.

Figure 7 shows a block diagram of the telemetry system in the satellite and at the test station. After reception at the test station the data are processed and separated into three categories designated class I, class II, and class III.

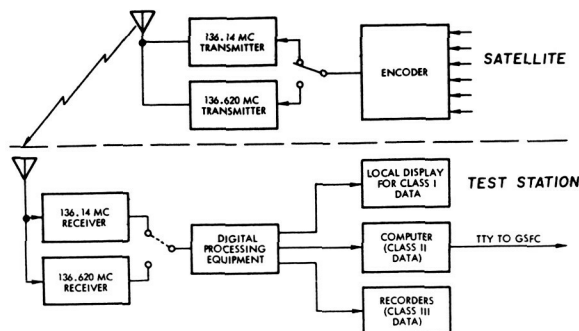

FIGURE 7.—Relay telemetry system.

Class I data are reduced in real time and may be used for making a GO/NO-GO-spacecraft-operation decision. There are nine such items of information. A digital limit checker compares the incoming signal values against preset limits. If all critical values are within tolerance, a row of green lights appear. If a signal is out of specification, a red light appears and an alarm is sounded. Since the lights are labeled, the operator can tell immediately which parameter is faulty. The class I data are also recorded in analog form on a paper strip recorder.

Class II data consist of 34 items of spacecraft telemetry and are utilized to determine spacecraft condition in more detail than is available from class I data. Class II data are also reduced in real time, formatted for transmission over a teletype circuit, and transmitted to Goddard Space Flight Center in order that the detailed status of the spacecraft can be observed immediately prior to, during, and following utilization of the spacecraft.

Class III data contain all of the class I and II and radiation experiment telemetry data. Class III data are recorded on magnetic tape for future data reduction. The tape recorder also records digital time for proper time tagging of events. Recording tapes are sent to the Data Reduction Center at Goddard.

Figure 8 is a block program illustrating the flow of information in controlling and scheduling the satellite.

The Project Relay satellites have performed very

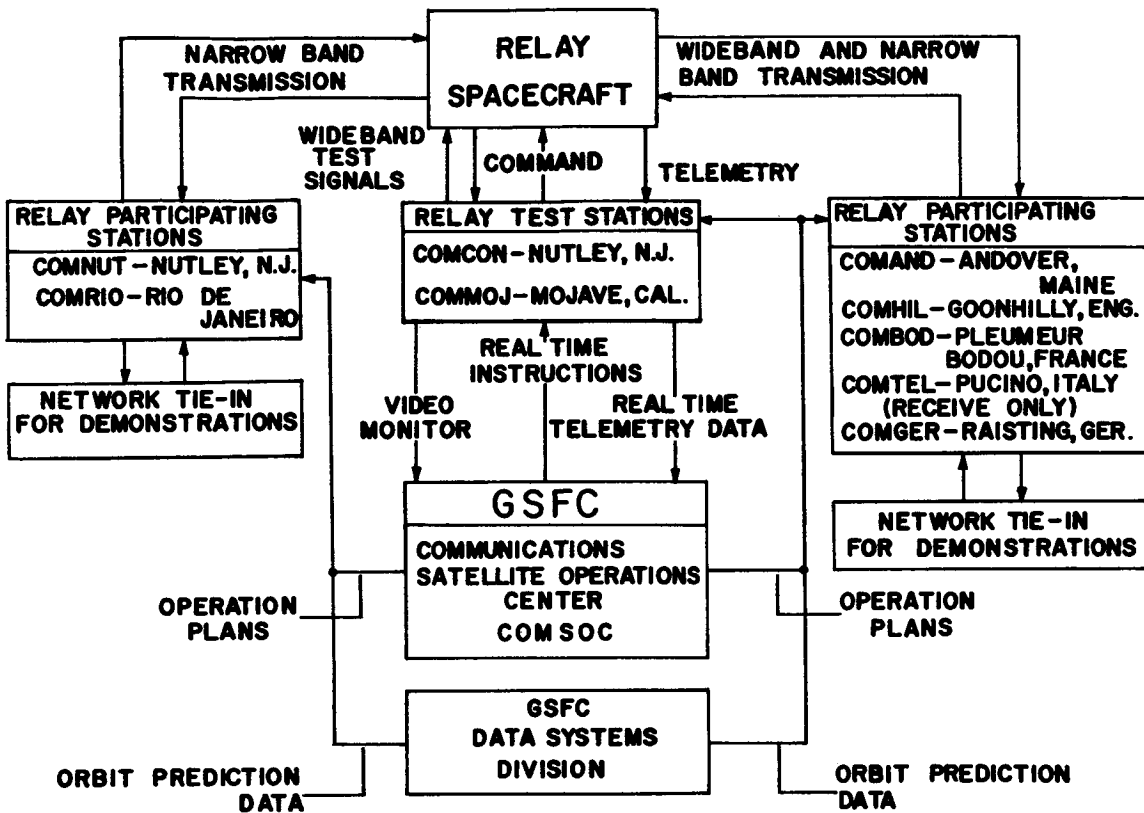

FIGURE 8.—Relay operations control system.

well as a communications medium. The large number of experiments conducted by all the participating stations validated the original system design philosophy and the choice of operating parameters. The fact that the repeater is a moving vehicle in a space environment has presented no particular difficulties not encountered with a ground microwave relay system.

The communication system in the Relay satellite receives the 1725 Mc transmitted signal and retransmits at 4170 Mc. The system is capable of supporting one television signal or 300 one-way telephone channels at a time. The satellite can be switched to a narrowband mode which can provide 12 simultaneous two-way channels. As of April 8, 1964, the Relay I spacecraft has been used for 1,372 wideband experiments, 653 narrowband experiments, and 172 demonstrations; and the transponder had been operated for 302 hours during 760 operations. In addition, there has been much radiation data taken. The general results of the communications experiments are summarized below.

The Relay system test categories are as follows:

Wideband (television and 300-channel telephony)

- Received carrier power
- Noise—random, periodic, and impulsive
- Linear distortion
 - Waveform tests
 - Steady-state characteristics
- Nonlinear distortion
 - Differential gain and phase
 - Differential time delay
 - Intermodulation noise
- Television test signals

Narrowband (12-channel telephony)

- Received carrier power
- Noise—random, periodic, and impulsive
- Linear distortion
- Nonlinear distortion
 - Differential time delay
 - Intermodulation—harmonic and noise loading
- Intelligible cross talk

The wideband communication experiments consist principally of tests designed to evaluate the Relay system with respect to its ability to transmit a television picture and sound. However, two of the experiments are directly related to the transmission of frequency-division multiplex (FDM) telephony by means of frequency-modulated (FM) carrier. The wideband mode of the satellite was designed to accommodate 300 FDM/FM telephone channels in half-duplex (one-way) operation. The narrowband communication experiments are designed to evaluate the ability of the system to transmit 12 two-way FDM/FM voice channels. In addition to voice transmission, these telephone channels can handle several frequency-shift keyed (FSK) teletype channels or facsimile. A number of public demonstrations also have been conducted using the telephone and television capabilities. The communication performance of the Relay communication satellite system can be conveniently summarized in the framework of the experiment categories shown above.

In the thermal-noise-limited Relay system, adequate received carrier power is essential. Generally, fair agreement between predicted and measured carrier power has been obtained. Nevertheless, it is not unusual to observe discrepancies of several decibels during a typical pass. A system margin of 5 to 6 db to provide for such occurrences therefore seems mandatory in future system design. Because of the vanishing margins at the smaller stations, difficulty in making some of the communication tests has been encountered. Phase-lock demodulators have been utilized and proved their worth in lowering the minimum received signal power required. Without them, additional spacecraft with effective radiated power or lower noise ground stations with greater antenna gain would be necessary. Operation near threshold has been hampered by the modulation on the carrier because of the spin of the satellite. Spin modulation has also caused some difficulty in autotracking for some stations when at high-elevation angles.

Agreement between predicted and measured post-detection signal-to-noise ratios has been in most cases less satisfactory than for received carrier power. This is primarily due to the difficulty in predicting the characteristics of the baseband noise and its effect on the signal at low levels.

Linear waveform and steady-state response tests have indicated that the satellite contributes slightly to linear distortion. This was expected. Linear dis-

tortion is principally a function of the baseband equipment. Since this equipment is not substantially different from that which would be used in a ground microwave relay, except for greater deviations and bandwidths, the design considerations and problems should be similar.

Substantial nonlinear distortion, on the other hand, has been discovered both in the ground equipment and the satellite. Differential gain measurements have shown the baseband equipment to be relatively free of nonlinear distortion. Differential phase and differential time delay, however, exist both in the ground and satellite IF and/or RF equipment. The differential phase was found to be excessive for the transmission of quality color television, for example. However, with preemphasis and some delay equalization in the ground stations, the system could be used for color transmissions. Reasonable agreement between differential phase and delay measurements has been obtained.

The intermodulation noise in a telephone channel for the wideband mode also has been predicted from differential delay measurements and verified by noise-loading stimulation of the voice channels. In general, the intermodulation noise appears to be at or above the Relay objective, especially in the wideband mode. It would appear that some delay equalization would be appropriate. Such equalization should not be difficult to apply, since a substantial portion of the distortion appears to be located in the ground equipment.

In the narrowband mode, measurements indicate that intelligible cross talk would be a problem in a system like Relay unless complementary channel operation is employed. Complementary channel operation means that a speaker talks and listens in the same baseband frequency slot. "Intelligible cross talk" then becomes echo under these conditions. An important source of intelligible cross talk is AM-to-PM conversion in the spacecraft TWT transmitter. Cross talk could be reduced by operating this tube below saturation, but this would penalize the system by reducing the satellite power output.

The Relay project has demonstrated the feasibility of a long-life satellite and the use of this satellite in a communications link. It also, with the Telstar project, provided the inducement to other nations to develop and install ground stations for use with communications satellite systems. These ground stations now are available for use with the commercial system

to be established by the Communications Satellite Corp. The experience gained in controlling, scheduling, and operating the Relay satellite will be of great value to the corporation in establishing their system.

A satellite in an equatorial orbit with a period of 24 hours will appear to be stationary from all points on the Earth's surface from which it is visible. Such an orbit has obvious advantages when applied to communications satellites. It does, however, impose the requirements on the satellite that it be accurately controlled in orbit. A satellite in an almost synchronous orbit is visible for long periods from any particular point on the Earth but, by the same token, is invisible for long periods from those same points. The problem is further complicated by the fact that, after the orbit is adjusted to exactly the proper one, it will, in general, not remain so. This is brought about by the fact that the Earth is not perfectly spherical and its gravitational field is, therefore, somewhat distorted. The satellite must, therefore, carry means of performing orbital corrections throughout its useful life. The Syncom project was designed to investigate the problems of placing a satellite in a synchronous orbit and maintaining it there for a useful lifetime.

Syncom II, the world's first active, synchronous orbit, communications satellite, was successfully launched on July 26, 1963 from Cape Canaveral, Fla. The satellite has been adjusted to a true synchronous orbit with the orbital node at 55° W. longitude and has been oriented to place the satellite spin axis perpendicular to the orbital plane. All systems and functions of the satellite have been proven and found to be normal with only minor exceptions.

The objective of the Syncom program has been met; the feasibility of a spin-stabilized, synchronous-orbit, active-communications satellite has been demonstrated. Orbital control has been achieved without difficulty. The launch by the Thor-Delta booster and apogee motor boost resulted in the expected near-synchronous orbit. Velocity corrections and spacecraft orientation have been made by the spacecraft control subsystem in a predicted manner.

The results of communications experiments have been excellent. High-quality voice signals have been transmitted with signal-to-noise ratios up to 40 db. Photographs have been transmitted by facsimile with a resolution greater than that of standard television. The main communications ground stations have been

able to lock on to the spacecraft beacon signals at elevation angles less than one-half degree.

It is predicted that satellite operation on full-duty cycles will be limited to 1 year by performance degradation of the satellite power supply. Operation can be continued beyond 1 year on lower-duty cycles by using the batteries to support the power demand. Degradation in other satellite subsystems and a gradual decrease in spin speed will not affect operation for several years.

The Syncom II satellite system consists of the spacecraft, ground-communications terminals, and telemetry and command ground-control stations. A computing facility for determination of proper orbit correction data is a necessary adjunct to the Syncom II system during critical orbit adjustment periods. The Minitrack network is used in satellite tracking.

The spacecraft was designed to be launched by the Thor-Delta vehicle and incorporates a solid-propellant apogee motor for changing from the elliptical-transfer orbit to a nearly circular synchronous orbit.

Communications ground stations are provided by the U.S. Army Satellite Communications Agency. Equipment for measuring range and range rate was supplied by NASA and was used in conjunction with the ground communication stations. One communication ground station was aboard the U.S.N.S. *Kingsport*, anchored in the port of Lagos, Nigeria. The other principal station is located at Lakehurst, N.J. A station at Fort Dix, N.J., is used as a backup to the Lakehurst station.

The telemetry and command ground-control stations are furnished by Hughes Aircraft Co. The primary station for spacecraft control and receipt of telemetry data during the launch and orbital period was aboard the U.S.N.S. *Kingsport* at Lagos. A station at Johannesburg, South Africa, served as a backup to the Lagos station during the launch and orbit-adjustment period. After orbital adjustment was completed, principal control was assigned to a telemetry and command station located at Lakehurst.

Satellite tracking was done by two methods: Johannesburg Minitrack station tracking of the spacecraft-communications signal, and telemetry and command-station tracking of the spacecraft-telemetry signal. The Minitrack data were used for initial orbit determination. The communications-station tracking data were the most accurate and provided a determination of spacecraft spin-axis orientation. Telemetry and

command station tracking was less precise than the other method, and was used as a backup.

Because of launch vehicle limitations, Syncom was placed in an inclined orbit rather than an equatorial orbit. The Syncom orbit is inclined approximately 32 degrees to the equatorial plane. This in no way, however, affects the validity of the results of the experiments.

To accomplish this, a Thor-Delta three-stage vehicle was used to place the satellite in an elliptical-transfer orbit with an apogee equal to the synchronous altitude of 19,300 nautical miles. When the spacecraft reached apogee, a solid propellant motor, which was an integral part of the spacecraft, was fired to furnish the additional velocity required to circularize the orbit at this altitude. At the completion of this maneuver the spacecraft was in an orbit that was slightly low in energy and was drifting in an easterly direction at a rate of approximately 8 degrees per day. This was well within the tolerances of the system. The spin axis at this time was in the orbital plane. Two changes in the spacecraft position were now required to put it in its intended position at 55° W. longitude with the spin axis normal to the orbital plane: (1) the satellite drift had to be changed from eastward to westward, and (2) the spin axis had to be rotated through 90 degrees.

The first correction consisted of an increase in energy or velocity to change the direction of the drift. The drift rate was changed from 8 degrees/day eastward to 4.6 degrees/day westward. The satellite spin axis was then rotated 90 degrees. This maneuver also changed the drift rate to about 7 degrees/day westward. By August 18, 1963, the satellite was essentially stopped at 55° W. longitude with a drift rate of 0.0012 degree/day. As of April 16, 1964, it was drifting westward at a rate of 1.3 degrees/day and was at approximately 105° W. longitude. This drift rate and position was the result of natural orbit perturbations and exercises performed with the control system.

Figure 9 shows an artist's conception of this launch sequence. The reorientation of the spacecraft is shown being accomplished prior to the velocity correction. The order in which these maneuvers are performed depends on the change required and is chosen to conserve the control capability as much as possible. Figure 10 shows the ground track of the satellite through launch and the first few orbits. The final position over 55° W. longitude is also shown.

Figure 11 is a photograph of the spacecraft. A major part of the spacecraft consists of the velocity- and attitude-control system. There are two independent systems: one using hydrogen peroxide and the other using nitrogen gas. The hydrogen peroxide system is more efficient in terms of spacecraft weight for a given amount of control and, as a result of experience gained with this spacecraft, will be the only type carried on future spacecraft of this kind. The nitrogen system was carried on Syncom because of a lack of experience with a hydrogen peroxide system in this mode of operation.

The communications subsystem contains two transponders: one narrowband, and one wideband. The narrowband transponder is required to relay, with high quality, two voice-modulated carriers (either FM or PM) between ground terminals having the characteristics listed in Table II. The wideband transponders transmit to the ground a reference signal derived from the master oscillator, which is used on the ground in a range and range-rate measurement system. The frequency of this reference signal falls in the passband of the ground receiver low-noise preamplifier.

TABLE II.—*Ground Station Characteristics*

Transmitter power.....	20 kilowatts
Transmitter antenna.....	30-foot-diameter parabola, 50 percent efficient, plane-polarized
Transmitter frequency.....	7360 ± 5 Mc
Transmitter modulation...	Angle modulation only (FM or PM)
Transmitted signal, RF bandwidth.	80 kc
Receiver frequency.....	1815 ± 5 Mc
Receiver antenna.....	30-foot-diameter parabola, 50 percent efficient, plane-polarized
Receiver preamplifier bandwidth.	10 Mc
Receiver IF bandwidth.....	100 kc maximum

The communications subsystem employs a frequency translation type of transponder having a 2-watt (nominal saturated power output) traveling-wave tube for its power amplifier. The main beam of the transmitting antenna is broad enough to encompass the Earth at all times.

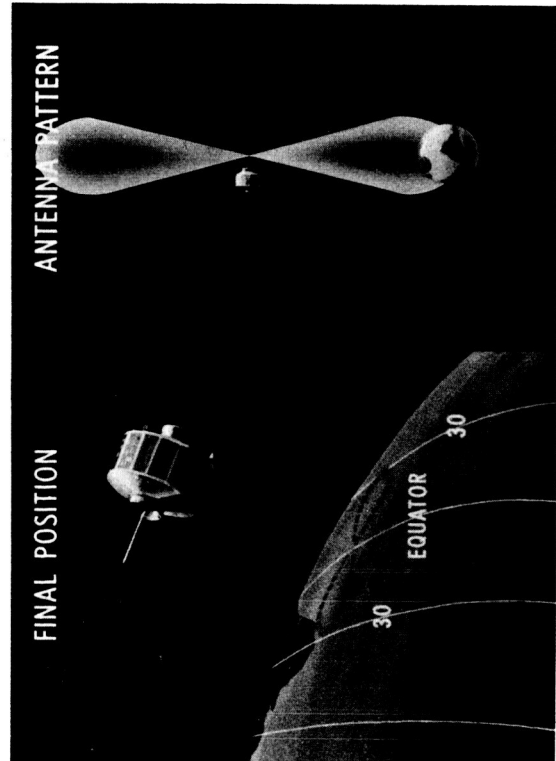
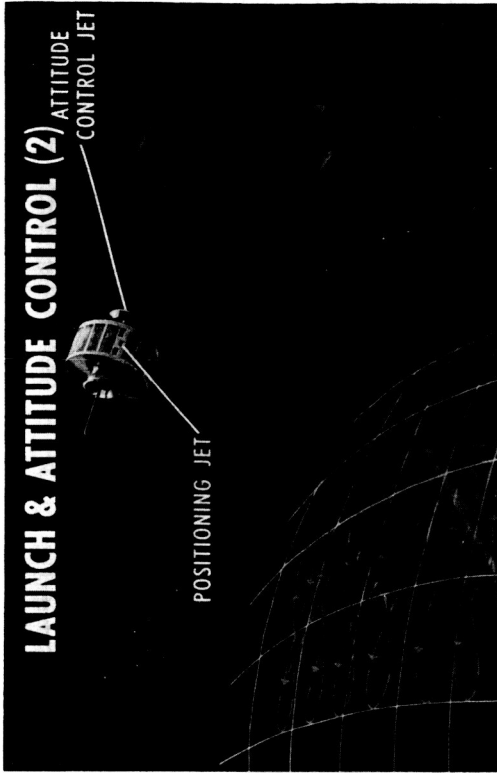
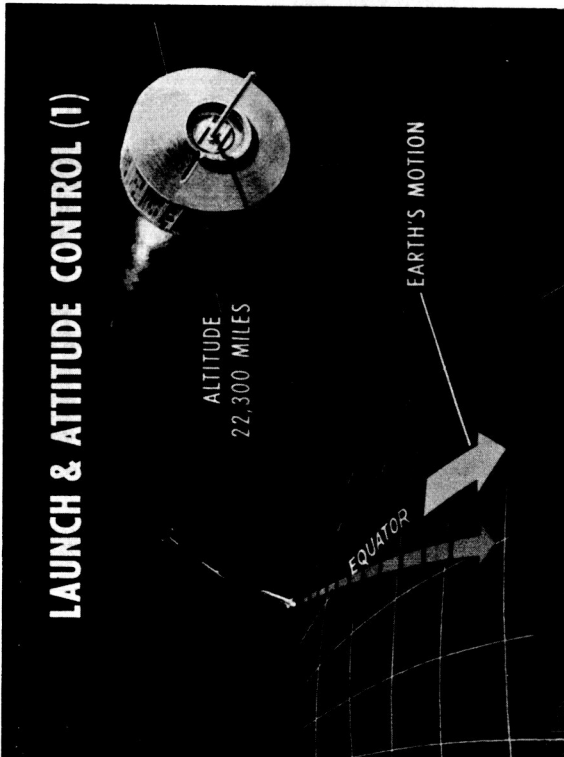

FIGURE 9.—Syncom launch sequence.

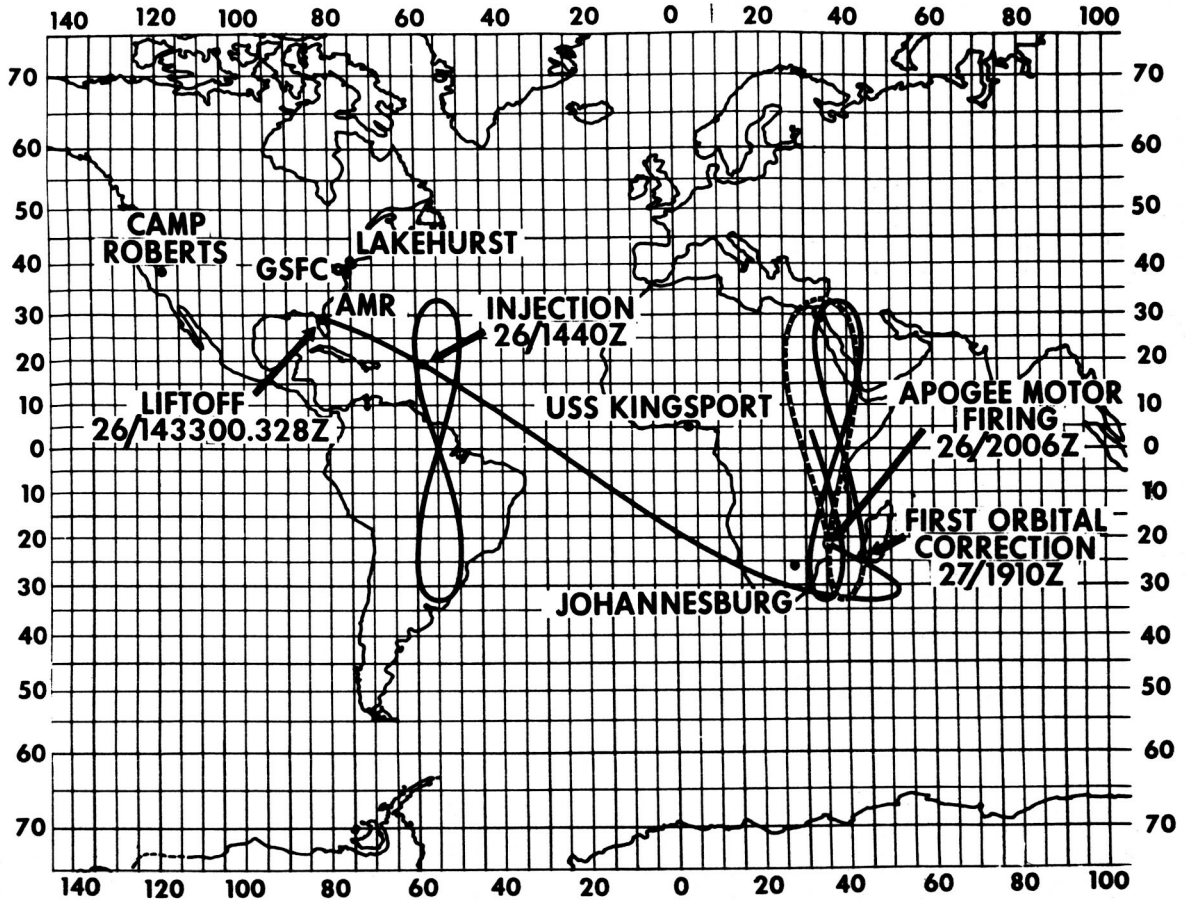

FIGURE 10.—Syncom ground tracking.

The spacecraft power supply and thermal design allows for continuous operation of the communications system except during and shortly after periods of eclipse.

Some of the more important characteristics of the transponder are listed in table III. The transponders are interconnected in a manner that will allow either receiver to drive either transmitter. Only one receiver and one transmitter may be used at a time, the selection being made by ground commands. The interconnections among antennas, receivers, and transmitters are accomplished by stripline hybrid networks and a coaxial switch. These units, along with the receiver input mixers and preamplifiers, are packaged in the central member of the structure. All other units are mounted along the outer cylinder.

The signals received by the slot-dipole antenna are

introduced with less than 1 db loss into the mixer of the ON receiver. This is accomplished by using half-wave lengths of cable between the input junction and the mixers and by back-biasing the crystal detectors of the OFF receiver, causing a high impedance to appear at its input junction. The received signals are converted to intermediate frequencies in the mixer with a reference frequency, 7396 Mc, that is the 256th harmonic of the master crystal oscillator which operates at 28.8917 Mc.

The frequency multiplication is accomplished in eight doublers, of which all but the first involve the use of varactor diodes connected push-push in efficient duo-mode networks. The first doubler uses a conventional transistor circuit. When using the narrow-band transponder, the two IF signals are amplified in a common linear amplifier consisting of a preamplifier

having a 3.5 db noise figure and a postamplifier, with a combined gain of 90 db. At this level, representing a combined carrier power of approximately 1 milliwatt, the signals are split into two channels having separate filters, limiters, and squelch circuits which are used to prevent receiver noise from loading the transmitter when a carrier is absent.

TABLE III.—*Transponder Characteristics*

Transmitter type.....	Traveling-wave tube
Transmitter power output.....	2 watts (nominal)
Transmitter carrier frequencies.....	1814.969 Mc, 1815.794 Mc
Transmitter reference frequency.....	1820.177 Mc
Beacon power.....	100 milliwatts
Receiver type.....	Frequency translation
Receiver carrier frequencies:	
Narrowband.....	7361.275 Mc, 7363.000 Mc
Wideband.....	7362.582 Mc
Receiver noise figure.....	10 db
Receiver channel bandwidth:	
Narrowband.....	500 kc (each channel)
Wideband.....	5 Mc
Antenna type.....	Skirted collinear slot dipoles
Receiving antenna gain.....	2 db (excluding losses)
Transmitter antenna gain.....	6 db (excluding losses)
Total transponder weight.....	103 ounces (each)
Total transponder power consumption.....	14.6 watts

A portion of the master-oscillator power is added to the receiver signals after they have been limited, and the combined signals are passed through a common limiter and introduced into the second mixer. The reference frequency of the second mixer is 1849 Mc, the 64th harmonic of the master oscillator. The output signals are filtered and introduced into the interconnecting hybrid which drives both transmitters, at a power level of 1 milliwatt each.

The wideband transponder is the same as the narrowband except for the IF amplifier. The signal is received from the postamplifier and is further amplified and limited. There is no squelch circuitry associated with the wideband transponder. The beacon signal is added in the same way as the narrowband case.

The transmitters are traveling-wave tubes having a signal gain of 33 db, and nominally 2 watts of power output. The dc power for all tube elements is sup-

plied through dc-to-dc converters, the inputs of which are regulated —24 volts. The power out of the ON transmitter is directed to a collinear slot array antenna by a latching coaxial switch.

The telemetry subsystem consists of two phase-modulated 136-Mc transmitters; two frequency-modulated, time-division multiplexed encoders with analog telemetry inputs; and an antenna unit shared with the command subsystem by frequency diplexing.

A turnstyle antenna oriented at 25 degrees to the spin axis of the spacecraft is used for command and telemetry. Gain is essentially isotropic, the variations with spacecraft attitudes ranging from a maximum of +0.5 db within 11 degrees of the perpendicular to the spin axis to a minimum of —3.2 db at the worst axis orientation.

The antenna is constructed of four quarter-wave whips at 90-degree intervals around the spacecraft circumference. The whips fold parallel to the spacecraft axis during ground handling and launch. Although this arrangement results in antenna detuning and mismatch, signal strengths during prelaunch checkout and liftoff tracking are sufficient because of proximity.

SUMMARY

On August 12, 1960, NASA launched the first satellite, Echo I, designed to investigate the use of artificial satellites in nonmilitary communication systems. This first passive communications satellite has been followed by Telstar I, Relay I, Syncom I, Telstar II, Syncom II, Relay II, and Echo II. All but Echo I and Echo II are active satellites, and all but Syncom I have been highly successful.

Successful communications experiments have been conducted by several agencies using the passive satellites Echo I and Echo II, including experiments by the United Kingdom and the U.S.S.R. with Echo II.

Telstar I, Telstar II, Relay I, and Relay II all have been used in intercontinental experiments and demonstrations. Relay I has had a lifetime of over 16 months in orbit.

Syncom I was successfully launched, but the electronic equipment failed to operate in orbit. Syncom II has been very successful and has been used to demonstrate our ability to place a satellite in a 24-hour orbit and control its position there.

The state of the art has been taken to the point where the Communications Satellite Corp. is now planning an interim system for commercial use and making long-range plans for a more sophisticated system.

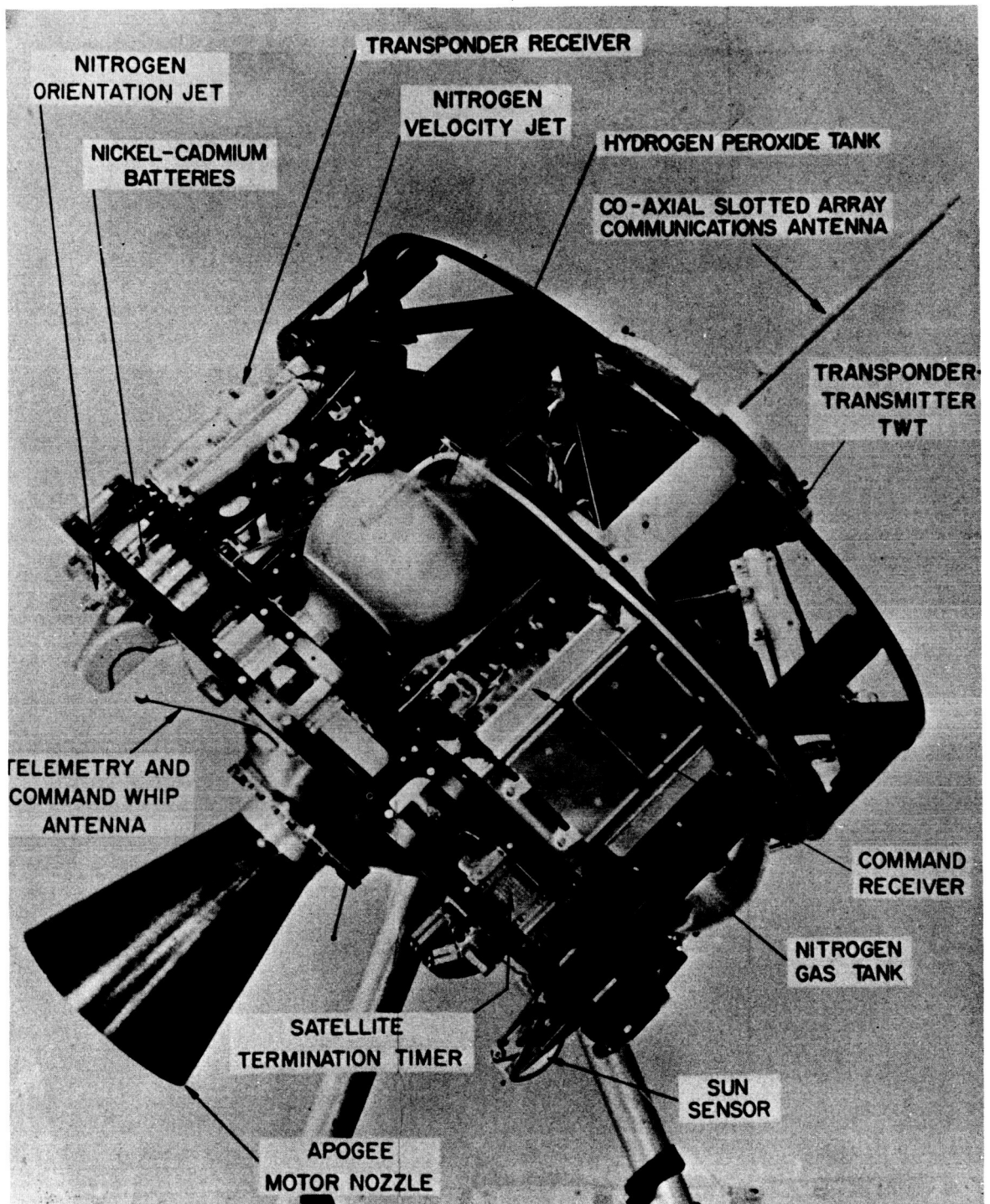

FIGURE 11.—Syncom II.