

June 1964

Brief 64-10145

NASA TECH BRIEF



This NASA Tech Brief is issued by the Technology Utilization Division to acquaint industry with the technical content of an innovation derived from the NASA space program.

Flexible Fastener Allows Thermal Expansion

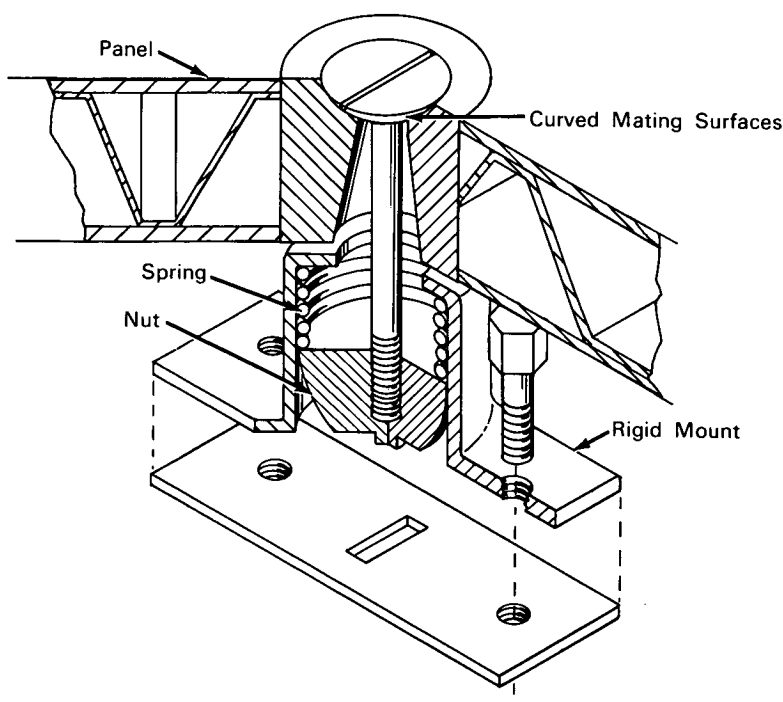

The problem: Provide flexible yet secure attachment of wind-tunnel research model skin sections. Thermal expansion of skin sections rigidly fastened to supporting structures produces stress concentrations which often cause the skin to rupture or buckle.

The solution: A flexible fastener that employs a modified ball-joint contact between the fastener and a skin section.

How it's done: The contact surfaces between the fastener head and skin section are mated to form a modified ball-joint. This allows the skin section to

move laterally without creating the large bending moments which would occur if the mating surfaces were flat. The threaded end of the fastener shank is secured to a spring-held nut housed in a rigid mount. A rectangular protrusion from the nut into a fixed slot prevents rotation during installation; however, it does not prevent wobble or vertical movement after installation.

Notes:

1. Although this fastener was designed to relieve thermally induced stresses, it may be used to

(continued overleaf)

connect two bodies wherein a provision for slight relative motion is necessary.

2. For further information about this innovation inquiries may be directed to:

Technology Utilization Officer
Langley Research Center
Langley Station
Hampton, Virginia 23365
Reference: B64-10145

Patent status: NASA encourages the immediate commercial use of this invention. It is owned by NASA and inquiries about obtaining royalty-free rights for its commercial use may be made to NASA Headquarters, Washington, D.C. 20546.

Source: Weymouth B. Crumpler
(Langley-40)