

July 1964

Brief 64-10144

NASA TECH BRIEF



This NASA Tech Brief is issued by the Technology Utilization Division to acquaint industry with the technical content of an innovation derived from the space program.

Ring Counter May Be Advanced or Retarded by Command Signal

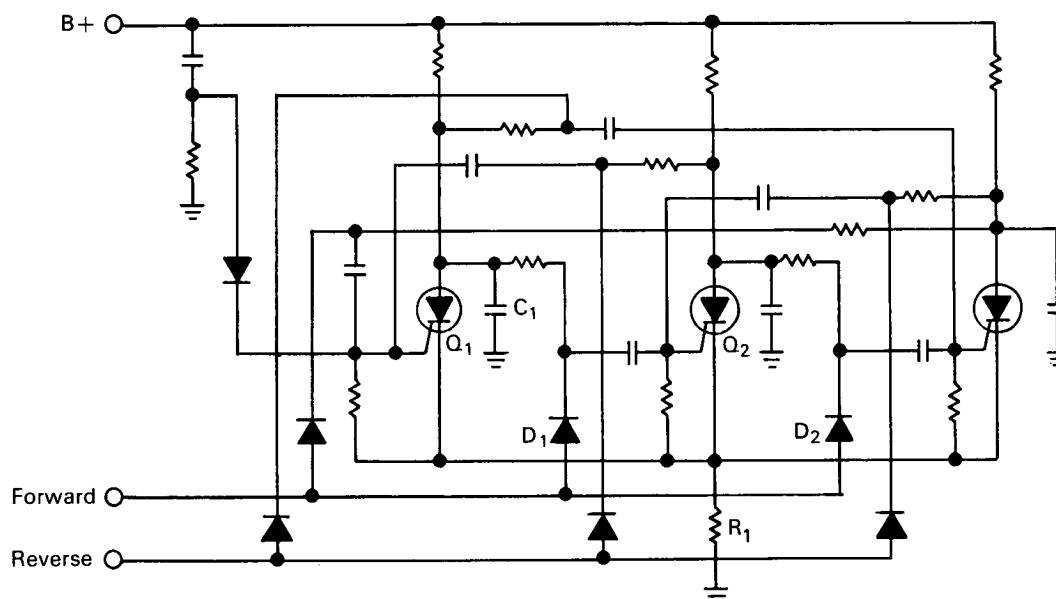

The problem: Driving small loads, such as lamps, relays, solenoids, and the like, in planned sequence forward or reverse. Previous designs have not included this bidirectional feature.

The solution: A power logic circuit in the form of a shift register with bidirectional capability.

How it's done: A reversible ring counter designed with rings or stages cascaded in any desired number. Each stage consists of a silicon-controlled rectifier (SCR), three capacitors, two resistors, and two steering diodes. When power is applied to the circuit, the charging of C_1 develops a positive pulse at the gate of Q_1 , which is turned on. The voltage at the anode of Q_1 will then be low while the anodes of all other stages will be at $B+$. In the presence of a

command forward pulse, D_1 is forward biased. All other diodes are reverse biased and not receptive to a pulse on the command bus. The command forward pulse will pass through D_1 to the gate of Q_2 , which is turned on. The discharge of C_1 through Q_2 into R_1 will then turn Q_1 off. D_2 is now forward biased to receive the next forward pulse, while D_1 and all other diodes are reverse biased. The circuit proceeds to step with each command pulse. The last stage is coupled back to the first stage thus completing the ring. Additional stages may be added as needed so long as the last stage is coupled back to the first stage. Stepping in the reverse direction is identical in that pulses on the reverse bus forward bias each succeeding diode to operate the SCRs in inverse order. This is the unique feature of this device.

(continued overleaf)

Notes:

1. This circuit may be used in place of a motor-driven switch or a stepping solenoid switch to achieve greater reliability.
2. This device can be used to drive any type of load up to 100 ma in step sequence forward or backward.
3. For further information about this innovation inquiries may be directed to:

Technology Utilization Officer
Goddard Space Flight Center
Greenbelt, Maryland 20771
Reference: B64-10144

Patent status: NASA encourages the immediate commercial use of this invention. Inquiries about obtaining rights for its commercial use may be made to NASA Headquarters, Washington, D.C. 20546.

Source: John N. Libby and Harry D. Moore
(GSFC-101)