

June 1964

Brief 64-10121

NASA TECH BRIEF

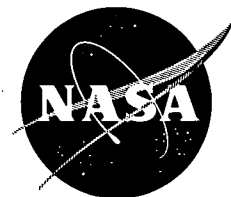

This NASA Tech Brief is issued by the Technology Utilization Division to acquaint industry with the technical content of an innovation derived from the NASA space program.

Electronic Assembly Rack Panels Snap On and Off

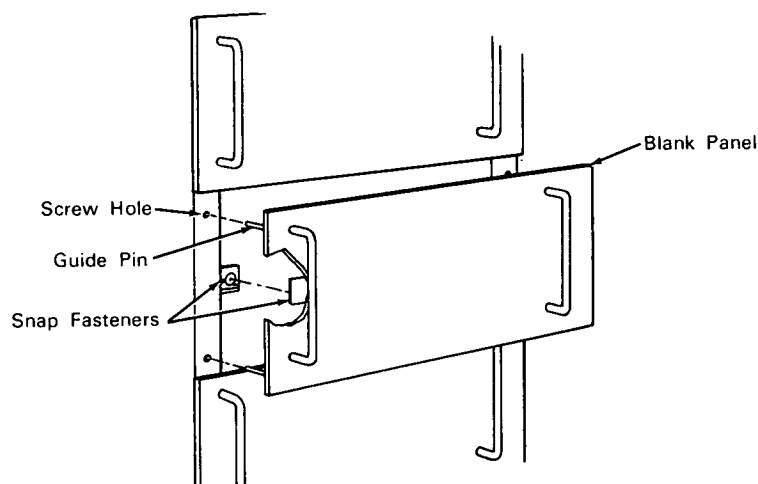

The problem: Quick fastening and unfastening of electronic assembly rack blank panels. The conventional method, requiring alignment of the panels and the use of screws to fasten them to the rack, is slow and awkward. Considerable time can be lost in removing screws when immediate access to the interior of the rack is required during operation of the electronic units.

The solution: A set of snap fasteners on each side of the panel. Guide pins extending from the face inside of the panel easily slip into standard screw holes on the frame of the rack and provide additional support to the panel.

How it's done: The panel is fastened to the rack by lining up the guide pins with matching mounting holes on the rack frame and inserting the panel with a light pressure. The panel is simply and quickly removed by gently pulling on the handles to release the snap fasteners.

Notes:

1. Wheel-and-clip, spring, or other fasteners may be utilized to provide the desired holding characteristics in this or other snap-panel applications.
2. For further information about this innovation inquiries may be directed to:
Technology Utilization Officer
Goddard Space Flight Center
Greenbelt, Maryland 20771
Reference: B64-10121

Patent status: NASA encourages the immediate commercial use of this invention. Inquiries about obtaining rights for its commercial use may be made to NASA Headquarters, Washington, D.C. 20546.

Source: James W. Bailey
(GSFC-59)