

October 1964

Brief 64-10069

NASA TECH BRIEF



This NASA Tech Brief is issued by the Technology Utilization Division to acquaint industry with the technical content of an innovation derived from the space program.

Metal-Bending Brake Facilitates Lightweight, Close-Tolerance Fabrication

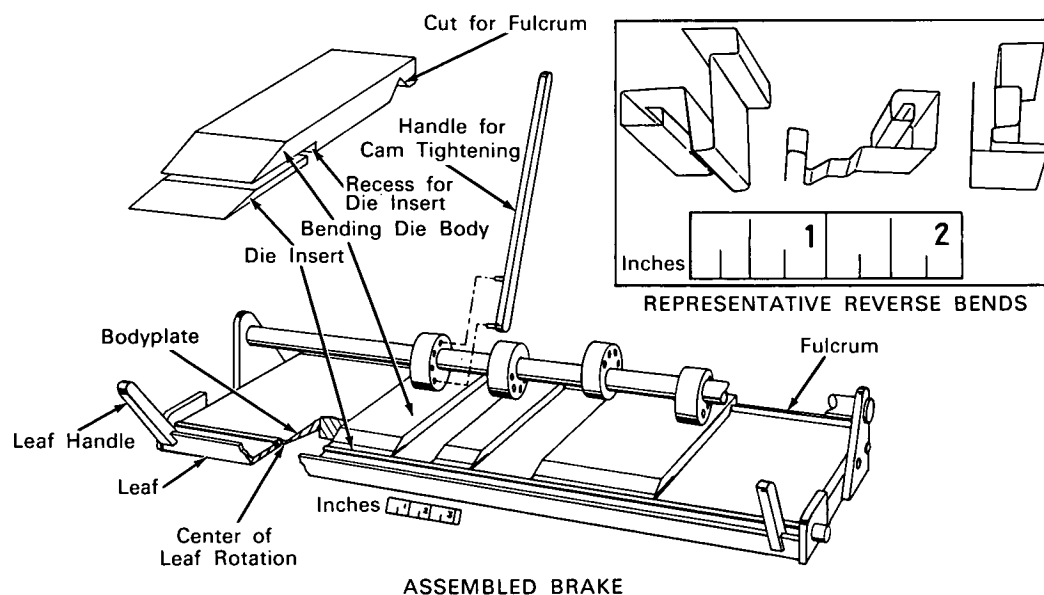

The problem: Making very accurate bends, including complex reverse bends, in small, lightweight, sheet-metal stock.

The solution: A small-sized bending brake for making all types of bends, including complex reverse bends, to close tolerances.

How it's done: The bending brake incorporates one or more cams that can be positioned and locked in place to apply a uniform force directly to the bending die bodies. This direct application of force combined with a rigid fulcrum bar and "V" recesses in die bodies prevents movement of the dies and thus ensures very accurate bends. The die inserts can be

easily removed and changed for particular jobs by releasing the cams. Features of the brake that adapt it for making complex reverse bends to close tolerances are a pronounced relief or cutaway of the underside of the bodyplate combined with modifications in the leaf design and its suspension.

Notes:

1. The design principles used for this small-sized bending brake can be applied to the construction of brakes of larger size and capacity. Such brakes are inexpensive to build and should find application in all metal-bending jobs where high accuracy, speed, and versatility are important.

(continued overleaf)

2. The brake has been in successful use at Ames Research Center for 0.025-inch-thick brass, aluminum, and copper sheet. It should be equally useful for work on steel sheet.
3. Inquiries concerning this invention may be directed to:

Technology Utilization Officer
Ames Research Center
Moffett Field, California, 94035
Reference: B64-10069

Patent status: NASA encourages the immediate commercial use of this invention. Inquiries about obtaining rights for its commercial use may be made to NASA Headquarters, Washington, D.C., 20546.

Source: Kenneth B. Wilton and
Alfred L. Ercoline
(ARC-29)