

June 1964

Brief 64-10024

# NASA TECH BRIEF



This NASA Tech Brief is issued by the Technology Utilization Division to acquaint industry with the technical content of an innovation derived from the NASA space program.

## Efficient Circuit Triggers High-Current, High-Voltage Pulses

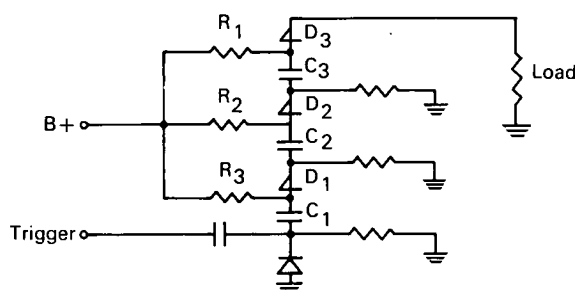

CONVENTIONAL CIRCUIT

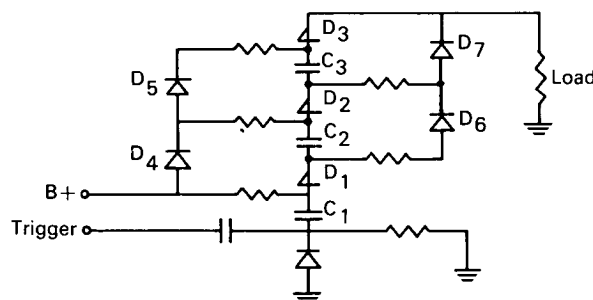

IMPROVED CIRCUIT

**The problem:** To design an efficient parallel-charging, high-voltage pulse modulator where low-voltage rating of components is an advantage. Conventional circuits for producing high-voltage output pulses dissipate a portion of their theoretical output power across the charging resistors.

**The solution:** A modified circuit employing diodes that effectively disconnect the charging resistors from the circuit during the discharge cycle.

**How it's done:** The diagrams of a conventional circuit and the improved circuit show three parallel stages for charging and a single stage for discharging

the capacitors  $C_1$ ,  $C_2$ , and  $C_3$  in series through the load. Either of the circuits can theoretically employ as many stages as required to produce an output voltage of the desired magnitude.

In the conventional circuit illustrated, the capacitors  $C_1$ ,  $C_2$ , and  $C_3$  are charged to the  $B+$  voltage through charging resistors  $R_1$ ,  $R_2$ , and  $R_3$ . A trigger pulse applied to  $C_1$  biases the four-layer diode  $D_1$  to a low-impedance state, opening a series conductive path from  $C_1$  through  $D_3$  to impress the sum of the voltages across the three capacitors onto the load. The output pulse, however, also appears across the charging resistors, where  $I^2R$  losses occur. Since the maximum

(continued overleaf)

voltage drop occurs in  $R_1$ , this resistor cannot be a low-voltage component, and the effect of voltage gradients must be considered. Currents larger than the diode holding current will flow through the charging resistor, making it difficult to turn the circuit off before the capacitors are completely discharged.

In the improved circuit, the diodes  $D_4$ ,  $D_5$ ,  $D_6$ , and  $D_7$  effectively disconnect the charging resistors from the circuit during the discharge cycle. This circuit thus allows the use of low-voltage charging resistors and eliminates power loss through these resistors, as well as the problems of voltage gradients and power turnoff associated with the conventional circuit.

**Note:**

For further information about this innovation inquiries may be directed to:

Technology Utilization Officer  
Manned Spacecraft Center  
P.O. Box 1537  
Houston, Texas 77001  
Reference: B64-10024

**Patent status:** NASA encourages commercial use of this innovation. No patent action is contemplated.

Source: Westinghouse Electric Corporation  
under contract to  
Manned Spacecraft Center (MSC-14)