

May 1964

Brief 64-10010

NASA TECH BRIEF

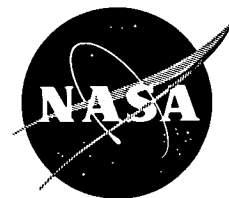

This NASA Tech Brief is issued by the Technology Utilization Division to acquaint industry with the technical content of an innovation derived from the NASA space program.

Modified RF Coaxial Connector Ends Vacuum Chamber Wiring Problem

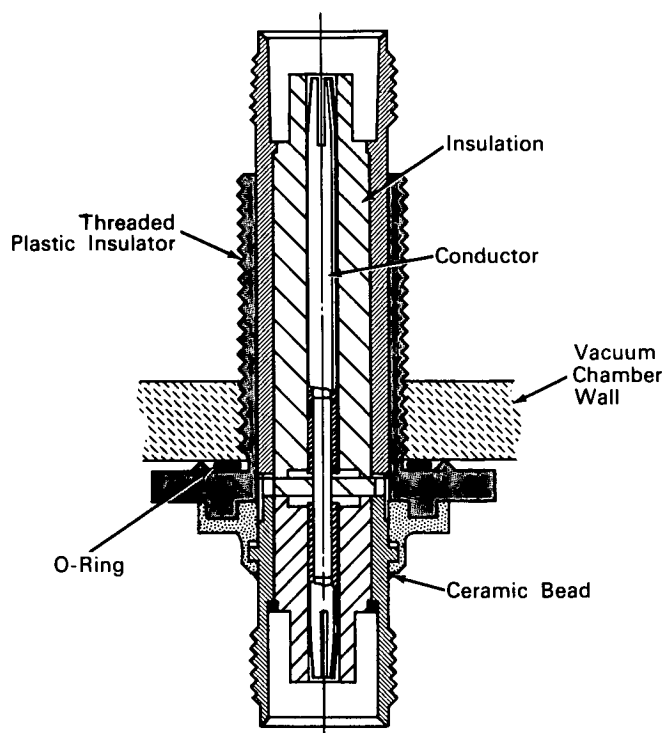

The problem: Tests conducted in a vacuum environment may require that radio-frequency signals be sent through the wall of the vacuum chamber. It is essential to eliminate ground loops and interference pickups when coaxial cables are connected from the inside to the outside of a metal chamber wall.

The solution: Modification of a standard radio-frequency coaxial connector so that a plastic insulating sleeve can be mounted in the wall of the vacuum chamber. Only a modest amount of machining, or other work, is required.

How it's done: A standard rf coaxial connector is modified by removing the outer threads of the connector. A molded plastic sleeve is pressed over the connector and then threaded. At the collar portion of the plastic sleeve a V-shaped ring, 1/32-inch high is machined to serve as a retainer for an O-ring. The O-ring assembled around the insulator seals the joint and preserves the vacuum in the chamber. Outside the chamber wall there is a retainer for the plastic insulator. A ceramic bead is soldered around the retainer for additional sealing.

(continued overleaf)

Notes:

1. This innovation would be of interest to laboratories equipped with vacuum chambers and to manufacturers of connectors, cables, or vacuum equipment.
2. For some applications, additional development would be required. It would be necessary, for example, to protect against the shock hazard from radio-frequency current.

3. For further information about this innovation inquiries may be directed to:
Technology Utilization Officer
Goddard Space Flight Center
Greenbelt, Maryland
Reference: B64-10010

Patent status: NASA encourages the commercial use of this innovation. No patent action is contemplated.

Source: David Weiner
(GSFC-150)