

July 1964

Brief 64-10007

NASA TECH BRIEF



This NASA Tech Brief is issued by the Technology Utilization Division to acquaint industry with the technical content of an innovation derived from the space program.

Low-Power Transistorized Circuit Provides Staircase Waveform

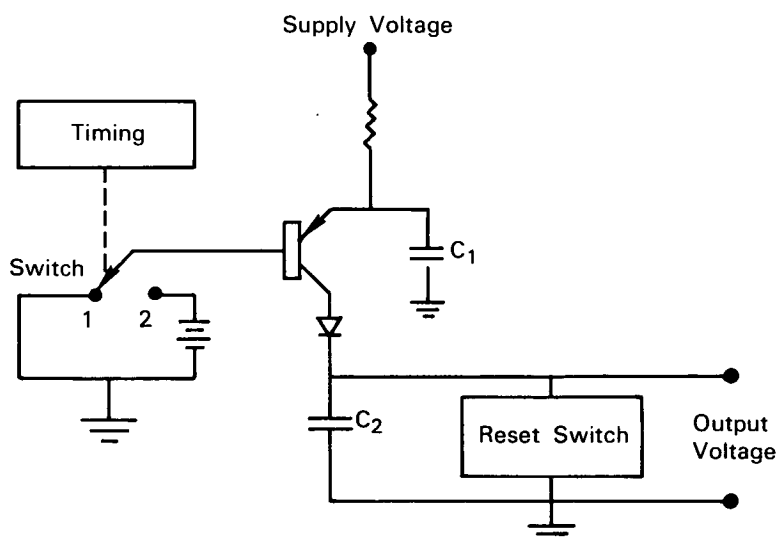

The problem: To generate a staircase waveform of high step uniformity, low step droop, and fast transition time using low input power and no feedback.

The solution: Transferring a charge from an input capacitor to an output capacitor in such a way that the transferred charge is independent of the state of charge of the output capacitor. Equal step increments are thereby achieved without feedback. Use is made of that property of a transistor whereby the collector current is proportional to the current flowing in the emitter circuit and independent, over a substantial range, of collector voltage.

How it's done: A capacitor C_1 is added to the emitter circuit of a conventional gating stage as shown in the illustration. The resistor is large enough to make C_1 the sole power source for the transistor. Since the energy stored in C_1 is finite and discrete, the gate

will remain open (conducting) during a timing pulse only as long as the emitter voltage remains greater than the base-emitter threshold. This RC circuit is designed, based on the low saturation resistance of the transistor, to decay within the duration of any reasonable timing pulse. The discharge of C_1 results in a pulse of collector current that imposes a discrete charge on the output capacitor C_2 and produces a corresponding step in the output voltage. The depletion of the charge on C_1 results in a quiescent cutoff condition in the transistor that continues through termination of that timing pulse to the point in the following pulse at which C_1 again is discharged. When the switch moves to position 2, the resulting rise in base voltage unclamps the emitter voltage that rises as C_1 charges through the resistor toward the supply voltage. Since steady state is achieved well in advance of the next timing pulse, the amount of charge stored

(continued overleaf)

in C_1 will be known and discrete. Thus the discrete increments made in the output voltage are independent of the number of previous charging pulses and unaffected by variations in timing pulse frequency.

Notes:

1. This circuit could be used to advantage in programming physical or biological experiments for display of a family of characteristics simultaneously on a CRT.

2. For further information about this innovation inquiries may be directed to:

Technology Utilization Officer
Goddard Space Flight Center
Greenbelt, Maryland 20771
Reference: B64-10007

Patent status: NASA encourages commercial use of this innovation. No patent action is contemplated.

Source: George D. Breen
(GSFC-48)