

## 15. NIMBUS TELEMETRY

By R. Golden, GSFC; F. L. Adkins  
and C. E. Griffin, Radiation, Inc.

## 15. NIMBUS TELEMETRY

### ILLUSTRATIONS

<u>Figure</u>		<u>Page</u>
1	Pulse-Code-Modulation Subsystem - Unit A, Block Diagram . . . . .	8
2	Pulse-Code-Modulation Subsystem - Unit B, Block Diagram . . . . .	9
3	Telemetry Electronics Subsystem . . . . .	10
4	Pulse-Code-Modulation Subsystem Module . . . . .	11
5	Module Board and Tray . . . . .	12
6	Module Board and Tray . . . . .	13
7	Video Input From Telemetry Receiver, Nimbus PCM Ground Station . . . . .	14
8	Bits Without Error vs. Signal-to-Noise, in DB, Nimbus PCM Ground Station . . . . .	15
9	Nimbus PCM Ground Station Equipment . . . . .	16
10	Nimbus PCM Ground Station, Block Diagram . . . . .	17

## 15. NIMBUS TELEMETRY

By R. Golden, GSFC; F. L. Adkins  
and C. E. Griffin, Radiation, Inc.

The purpose of the Nimbus pulse-code-modulated (PCM) telemetry subsystem is to gather, store (if required), and transmit to ground stations, the engineering information needed to evaluate the detailed performance, environmental conditions, and general function of all spacecraft subsystems. In addition, the Nimbus PCM telemetry subsystem provides all attitude information needed to determine the exact location of meteorological pictures.

The choice of pulse-code modulation over other types of telemetry was made because of its accurate and reliable data-transmission capability, and the ease with which the data can be reduced.

The Nimbus spacecraft will carry two electrically independent PCM units. Unit A handles 544 channels, which it continually records on tape for readout on command; unit B delivers 128 channels by direct transmission.

The PCM telemetry subsystem will accept information from all the spacecraft subsystems for "housekeeping" purposes and will also acquire control-subsystem attitude data. Information can be of the yes-no type or in analog form, stored by the unit A recorder for command readout, or for direct transmission by unit B upon interrogation.

Unit A consists of a 7-bit analog-to-digital converter, 544-channel multiplexer, subcommutation, gates and registers (Figure 1). It uses less than 0.75w of continuous power to monitor 542 data channels for information such as voltages, current, and temperatures, and to continuously check the performance of other spacecraft subsystems. These channels are time-multiplexed and serially recorded on tape at a bit rate of 500 cps for playback at 15,000 cps, a 30-to-1 ratio of time compression.

Frame composition is 64 words, including a synchronization word composed of all "ones". Maximum number of bits per word is eight,

including word synchronization. Subcommutation is used with the 8-bit synchronization word following the frame sync. Subcommutated groups 49 to 64 may be expanded to a total of 32 subframes simply by adding the necessary gate modules and timing circuits.

Unit A coder, similar to that used in unit B for redundancy, accepts asymmetric inputs from zero to -6.4v; channel input impedance is in excess of 100,000 ohms.

Unit B operates only upon ground command, using less than 0.25w operating power to scan the 128 channels for a 1.75-minute reporting period (Figure 2). This unit employs a bit rate of 10 bits/sec, with a maximum of 128 words, including synchronization with three words in the form of all "ones" followed by all "zeros", followed by all "ones". After completion of one frame, the unit is deenergized.

Unit B consists of an analog-to-digital converter similar to that of unit A, a multiplexer, gates, and a phase-shift modulator. Output of unit B phase-shift-modulates a 5000-cps coherent subcarrier. Modulator output is a 5000-cps sine wave. A 180-degree phase relation exists between a "one" and a "zero" when compared to a reference signal.

Units A and B both are controlled by signals from the Nimbus clock subsystem which furnishes 500-cps and 10-cps square waves, respectively, to the units.

For test purposes, telemetry data at 500 cps (not stored) can be read out from the PCM subsystem.

The non-return-to-zero (NRZ) output of unit A is converted in the "A" modulator, located in the telemetry electronics (TME) package (Figure 3). One cycle of a 500-cps sine wave is generated for each "zero" bit of information. The modulator output is stored on tape and may be read out directly. The TME unit also contains record amplifiers which furnish the record signal and the 8000-cps erase and bias signals to the tape recorder heads. Playback amplifiers, also located in this unit, provide an output to amplitude-modulate the beacon transmitter 80 percent. Dual record and playback amplifiers are available for a redundant tape recorder.

The TME unit includes a tuning-fork oscillator to provide 500-cps signals for the PCM unit A bit rate and "A" modulator, as well as a two-phase 100-cps signal for one tape recorder, in case the clock signals should be interrupted.

Command switches for the PCM, TME tape-recorder amplifiers, standby clock, tape-recorder functions, and transmitter input are located in the TME package. Clock signals and unit B signals are also routed through the TME for control and output to the beacon transmitter. Special test equipment is provided to check out all units of the PCM telemetry system.

The PCM and TME subsystems employ a unique packaging concept known as the "solid mass" approach to electronic packaging, which means that all portions of the system, including the components themselves, contribute to the rigidity of the package. By holding the internal parts in compression, the side panels need be only thin lightweight sections since they experience only tension forces. This results in a very high "electronics weight" to "box weight" ratio, as compared with other types of satellite electronic packaging. The PCM module (Figure 4) weighs less than 23 pounds; the TME (Figure 3), 5 pounds.

The printed circuit cards and module layout are very important as integral parts of the package. A novel concept is the face-to-face interlocking of module-card assemblies, not only resulting in structural rigidity, but also doubling the surface area of the available printed circuit boards, thus providing more room for module interconnections.

The interlocked module-card assemblies (Figure 5), or trays, are insulated from each other by a layer of cast polyurethane foam. The trays are interconnected through a special high-density lightweight connector developed for this special application by Radiation, Inc. and U. S. Components, Inc.

The modules are welded assemblies, potted with rigid polyurethane foam (Figure 6).

System testing begins with a module test. Following this initial test, the module is potted, X-rayed, and vibrated. The second test is performed with modules temporarily connected together as a system;

the first temperature cycling is done under this condition. Upon completion of these module-level tests, the system is assembled and the system test is also conducted over the temperature range. Not until the system has passed these tests is it put into the package and the acceptance tests started.

Environmental tests consist of the Nimbus subsystem sinusoidal and random vibrations, and thermal vacuum tests. The thermal vacuum tests are conducted with the entire telemetry system, including the Hughes beacon transmitter and the Raymond Engineering tape recorder. To date, a qualified prototype and flight-model PCM and TME have been delivered.

Two units, the Nimbus PCM tape recorder and the beacon transmitter, which complete the telemetry subsystem are extremely important in data transmission.

The Nimbus PCM tape recorder is a 4/0 pressurized module, weighing 10 pounds; power input is 1.6 watts during the record cycle, and 10 watts in the playback mode. A 216-foot, 1/4-inch-wide lubricated mylar endless-loop tape is used as the storage medium for the PCM "A" data. The tape unit records at a speed of 0.4 inches/sec and plays back at 12 inches/sec to give the 30-to-1 time compression. The 100-cps rate signal required for the drive mechanism is provided by the clock subsystem or the PCM emergency oscillator. The recorder module also contains motor-drive amplifiers for record, playback, and momentum compensation.

An internal automatic-turnoff device assures that the tape unit will return to its "record" mode after a playback of slightly more than the full length of tape, or approximately 3.6 minutes. The recorder utilizes a single head for record and playback, with switching of the respective amplifiers.

The physical distance between the erase and record heads provides a blank area on this magnetic tape at the moment the tape unit is interrogated. Knowing the exact time of the tape "gap" from command time, all data on the tape may be correlated to time with the known PCM bit rate.

The beacon transmitter continuously transmits Minitrack time except when PCM interrogation is commanded; during this period, PCM data are telemetered to a ground station. The transmitter, a solid-state device using a pre-aged crystal which assures a frequency stability of 0.005 percent, has a minimum CW output of 250 mw. The AM modulator's frequency response is flat within 3 db from 100 cps to 60 kc, and within 1 db from 200 cps to 30 kc. Distortion is less than 2 percent at 50-percent modulation. The transmitter output excites four quadrupole antennas located on the periphery of the Nimbus spacecraft.

To date, three beacon transmitters have performed successfully with PCM subsystems.

The Nimbus PCM ground station has been designed to accept all video outputs of the PCM telemetry receiver, and to process, record, and display the PCM telemetry data received from the satellite. The equipment will accept and speedily process the data, allowing an immediate review of information gathered during the satellite orbit. The station is designed to display the information visually and to prepare it for relay to remote facilities; it also can present visual displays of selected data on oscillographs for a quick look at the information as it is being received. In addition, it contains a computer complex for real-time and delayed editing and processing of the information.

The ground station will, while completely unattended, acquire data from the satellite with no commands from external equipment. It will recognize, program, acquire, and process any of the three PCM data formats in any sequence.

Figure 7 presents characteristic video waveforms of the data formats. The "B" PCM signal is 10-cps bit rate, non-return-to-zero-inverted (NRZI) on a 5-kc coherent subcarrier, phase-modulated 180 degrees. Each frame of "B" data consists of 128 data words. The "B" as well as both "A" formats contain word and frame synchronization groups.

Both "A" PCM signals contain 64 channels in a primary or minor frame. Thirty-two of the 64 channels are subcommutated to 16 minor frames. As shown in Figure 7, both "A" signals are NRZ signals amplitude-modulated on a coherent subcarrier. The real-time "A" data is received at a 500-cps bit rate, the tape-playback "A" data at a 15-kc bit rate.

System performance in the presence of noise is indicated in Figure 8, which presents measured versus theoretical signal-to-noise ratio versus bits without error plots for a 15-kc "A" data. The actual curve is approximately 3 db away from the theoretical, and predicts one bit error out of one million with a signal-to-noise ratio of 17 db.

Figure 9, a photograph of the ground station, indicates the major system components. From left to right, the picture shows a teletype send-receive set; a MinCom G107 magnetic-tape recorder-reproducer; two racks containing digital-to-analog converters and oscillographs; a two-rack acquisition station; and the computer subsystem, comprising a high-speed printer, digital magnetic-tape recorder-reproducer, and the computer console. Functions of each of these components are shown in the block diagram of the station (Figure 10).

The video output from the telemetry receiver is routed to the demodulators, which remove the subcarrier from the incoming signal and put out regenerated serial data. The video output is also routed to the MinCom tape recorder where a record of the incoming signal is made for delayed processing and for backup.

The regenerated serial PCM from the three demodulators is also recorded on the MinCom. Outputs of the demodulators are also routed to the synchronizers, where the word and frame sync patterns are recognized and the data is converted from a serial to a parallel form. Therefore, the output of the synchronizers is 7-bit parallel binary data, as well as the synchronization pulses and data-status signals required to process and display the data.

As shown in Figure 10, all "B" data are routed to the teletype where the raw data are printed out in decimal form in real time.

The output of the "A" data synchronizers is routed to two decommutators which, by means of a patchboard program, can select any 32 channels from the real-time or tape-playback "A" data required to be converted to analog information and plotted on the four- to eight-channel oscillographs.

All the incoming PCM data are routed through the computer-input circuitry to the CDC-160A computer console for processing, recording, and displaying under control of the program in the computer.



An outstanding feature of the ground station is its simplicity; there are no buttons or controls to be manipulated during a satellite pass, regardless of the sequence in which the PCM data are transmitted. Also, it is complete in that all the equipment required to process, record, and display the data is an integral part of the station.

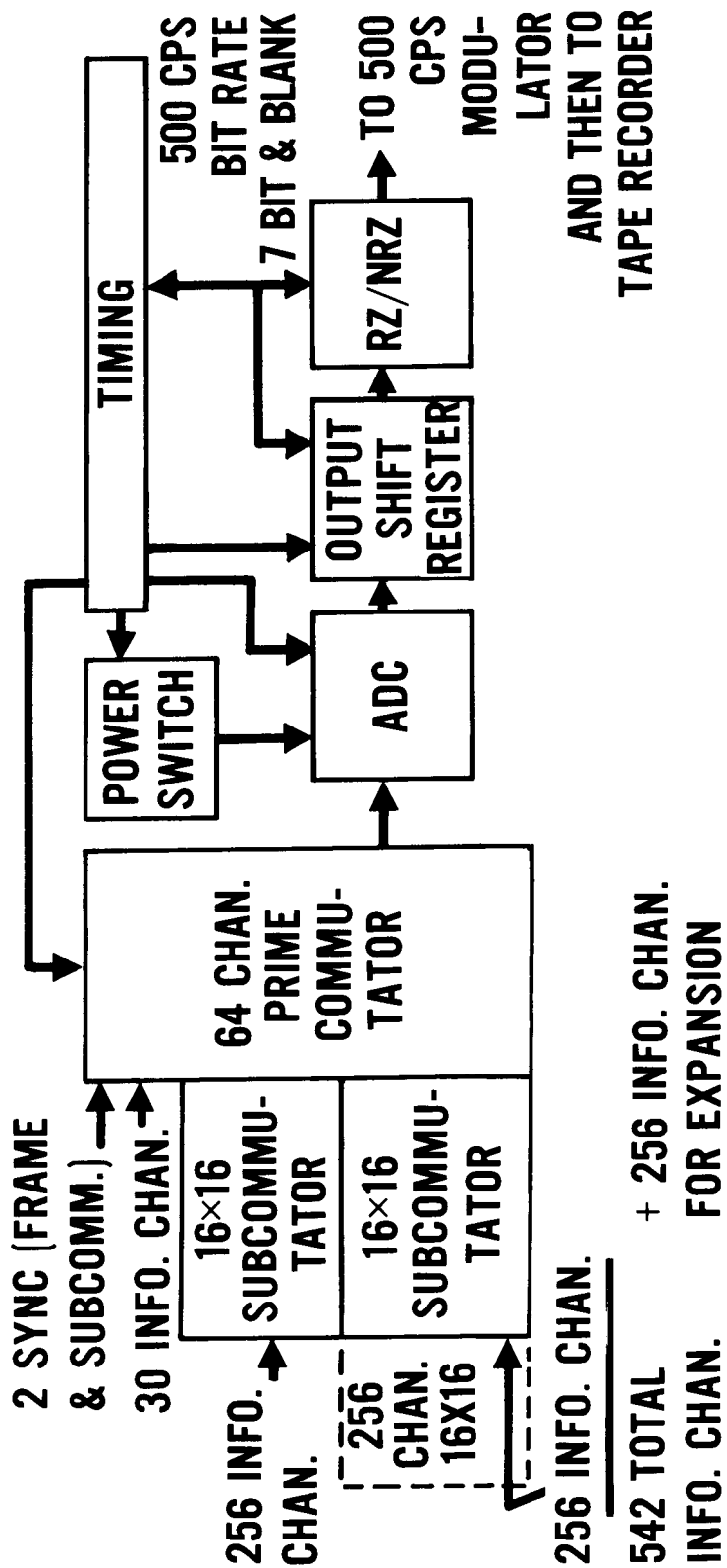

Figure 1 - Pulse-Code-Modulation Subsystem - Unit A, Block Diagram

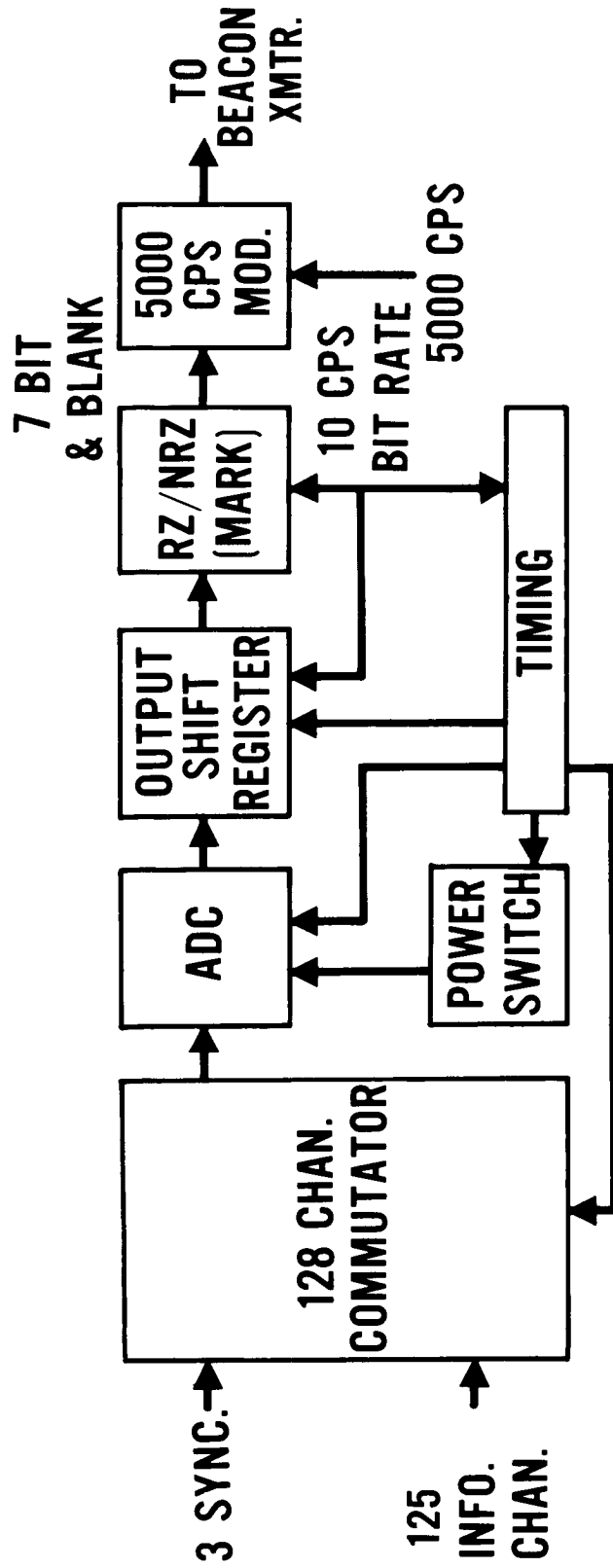

Figure 2 - Pulse-Code Modulation Subsystem - Unit B, Block Diagram



Figure 3 - Telemetry Electronics Subsystem

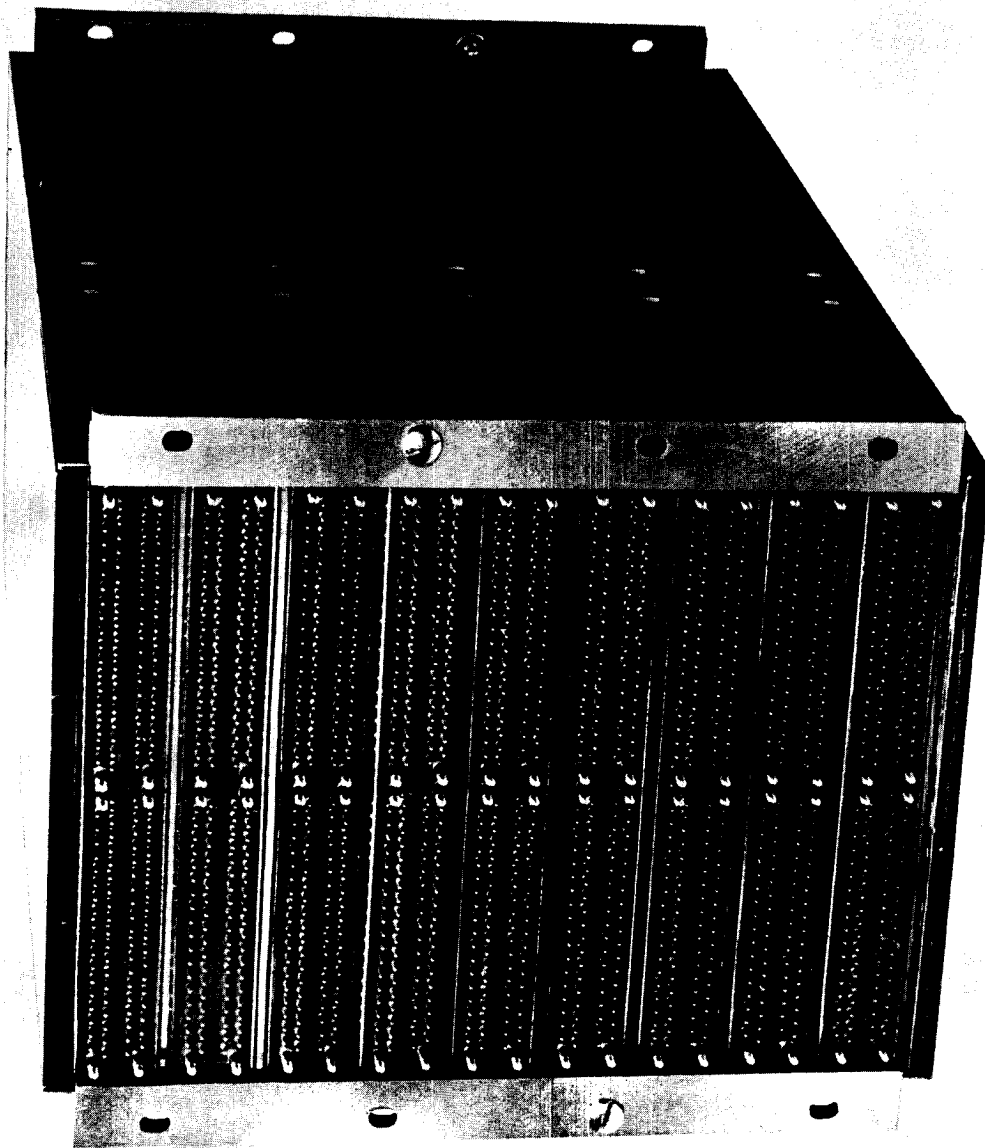

Figure 4 - Pulse-Code-Modulation Subsystem Module

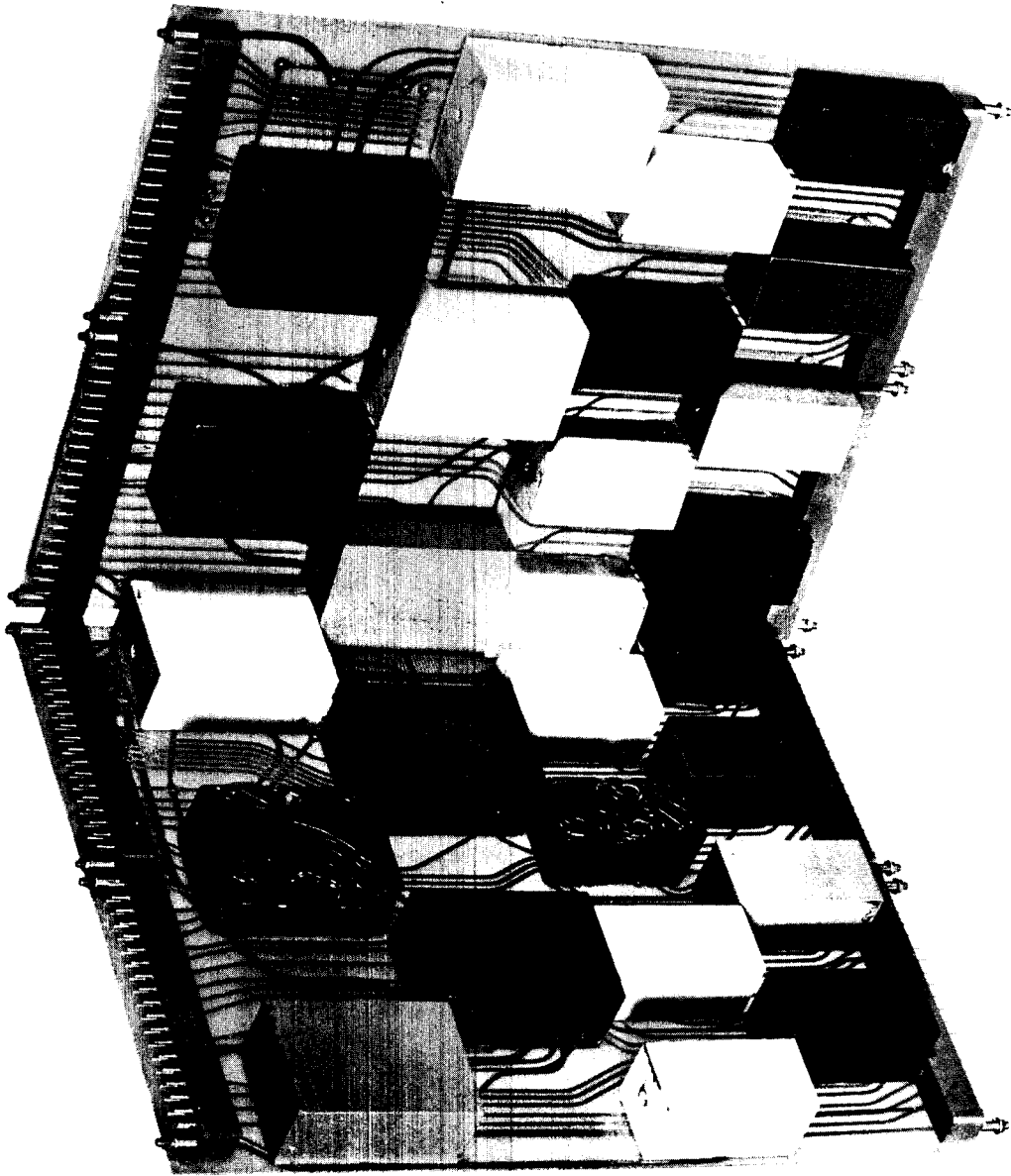

Figure 5 - Module Board and Tray

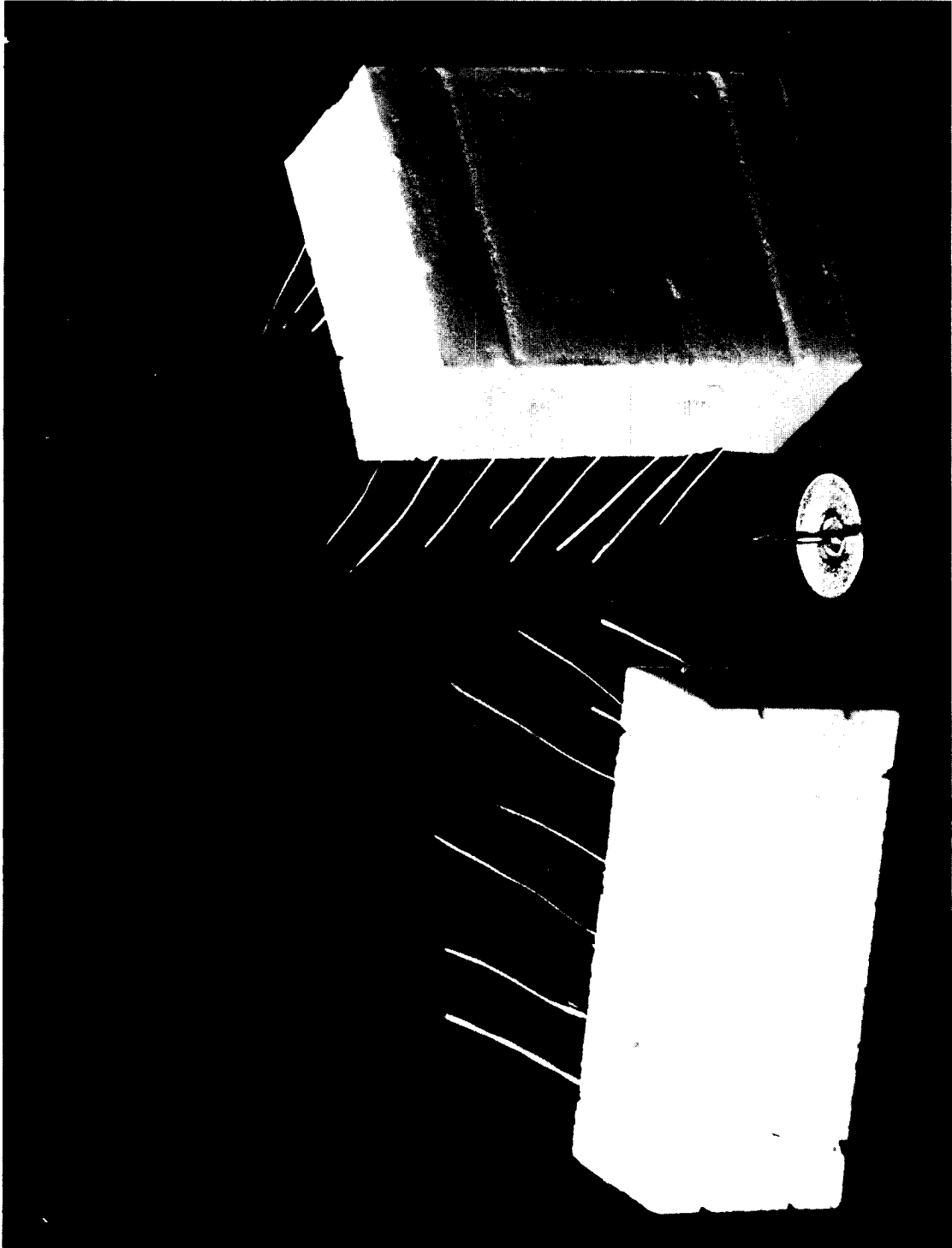

Figure 6 - Typical Modules

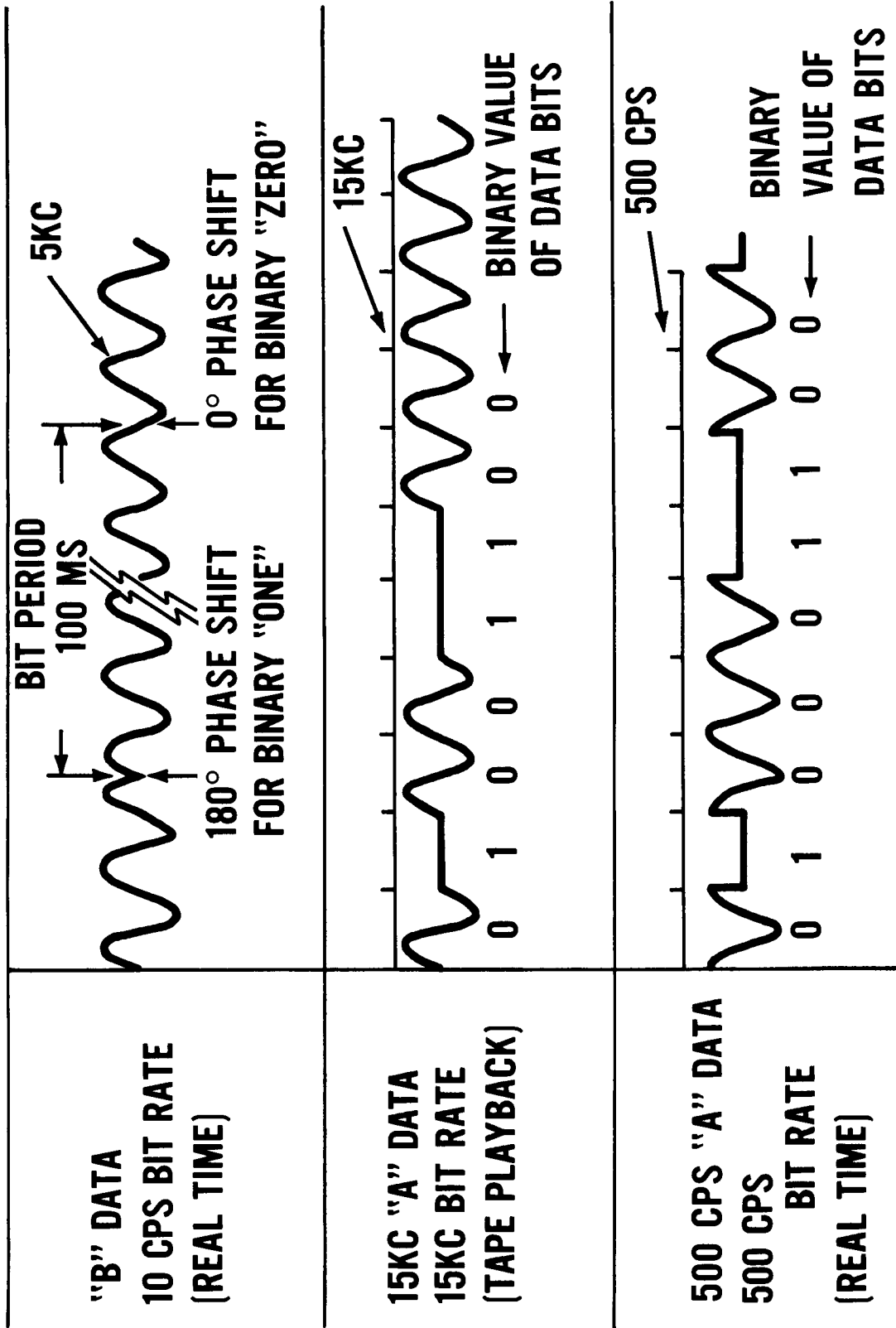

Figure 7 - Video Input From Telemetry Receiver,  
Nimbus PCM Ground Station



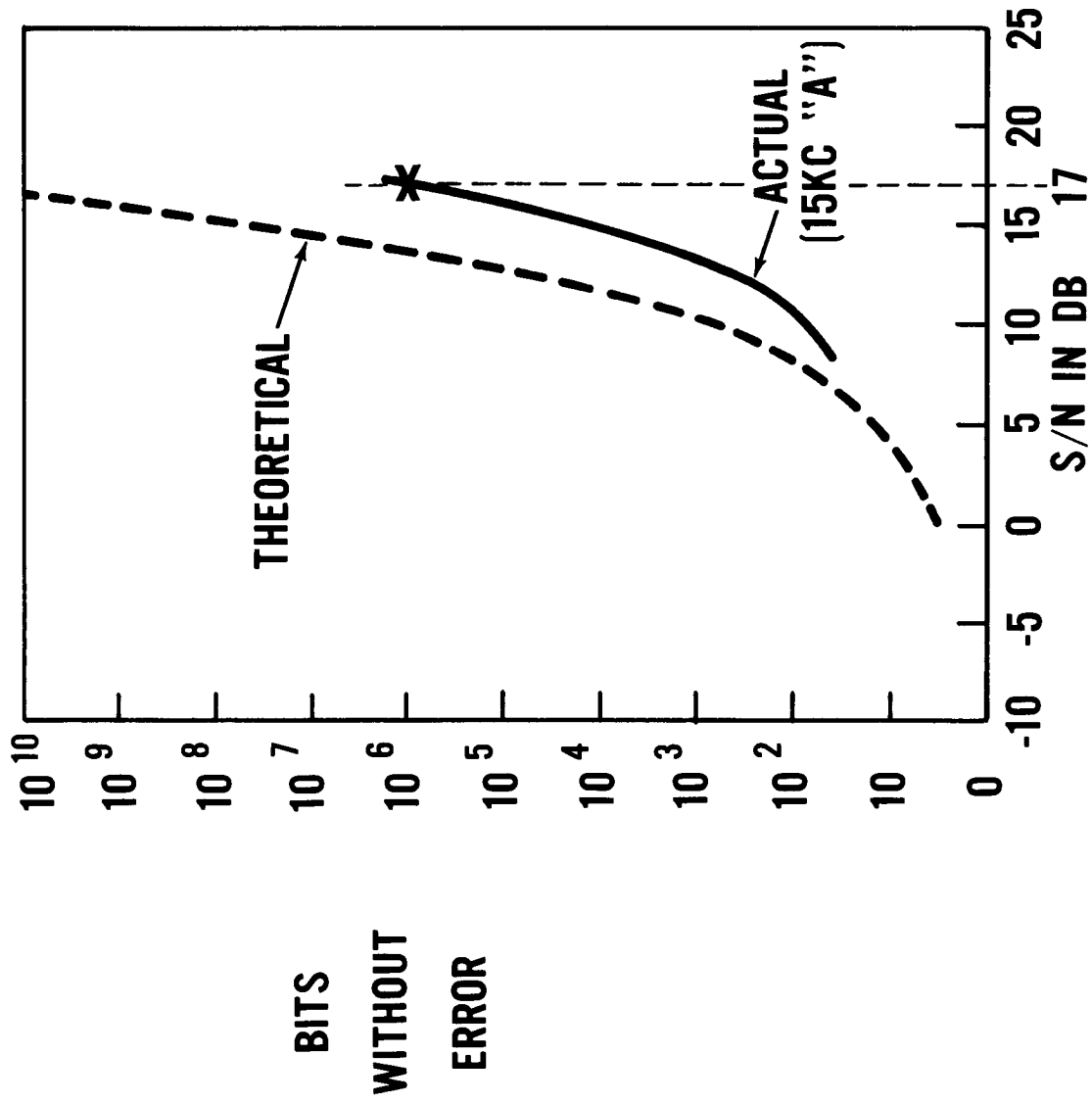

Figure 8 - Bits Without Error vs. Signal-to-Noise, in DB, Nimbus PCM Ground Station

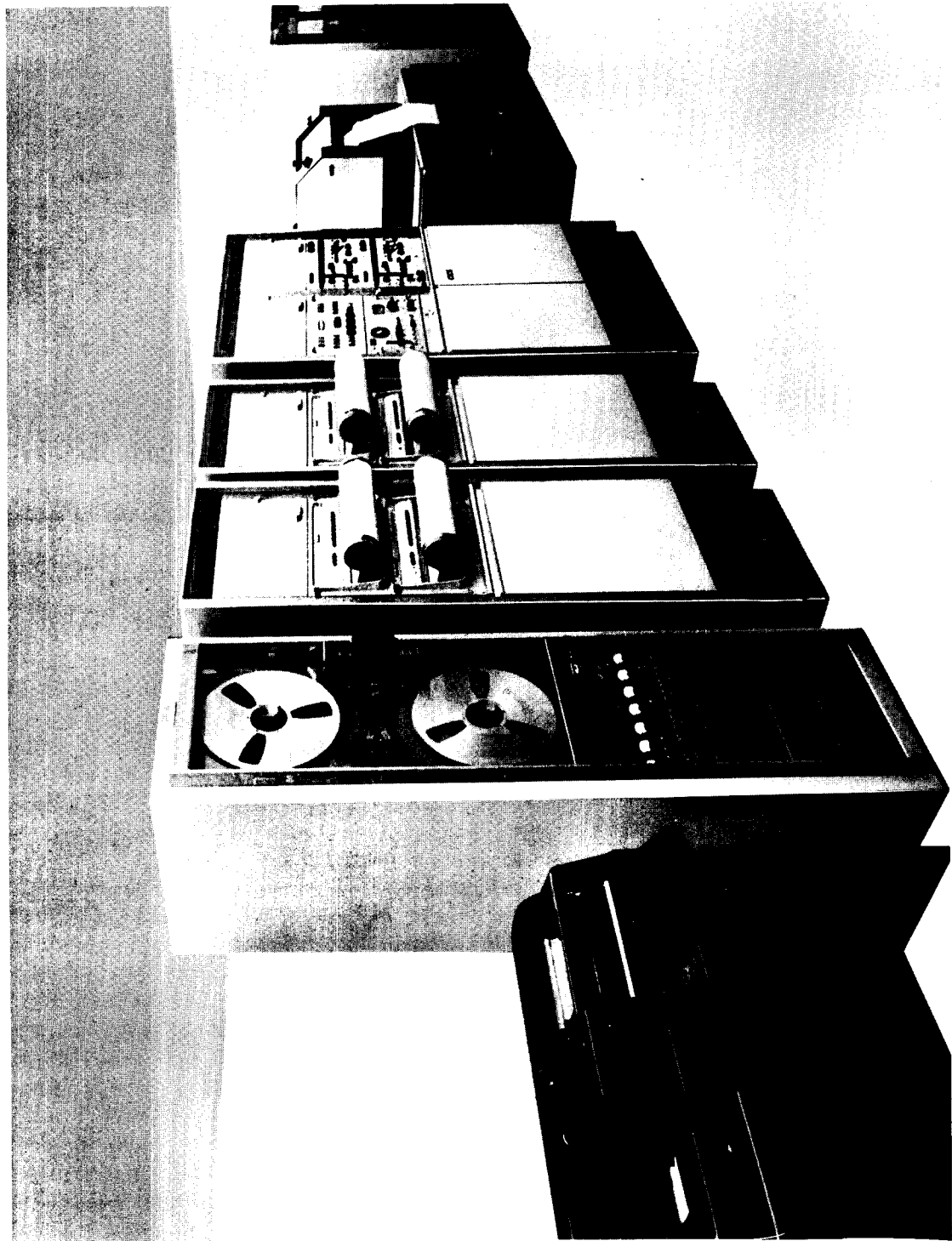

Figure 9 - Nimbus PCM Ground Station Equipment

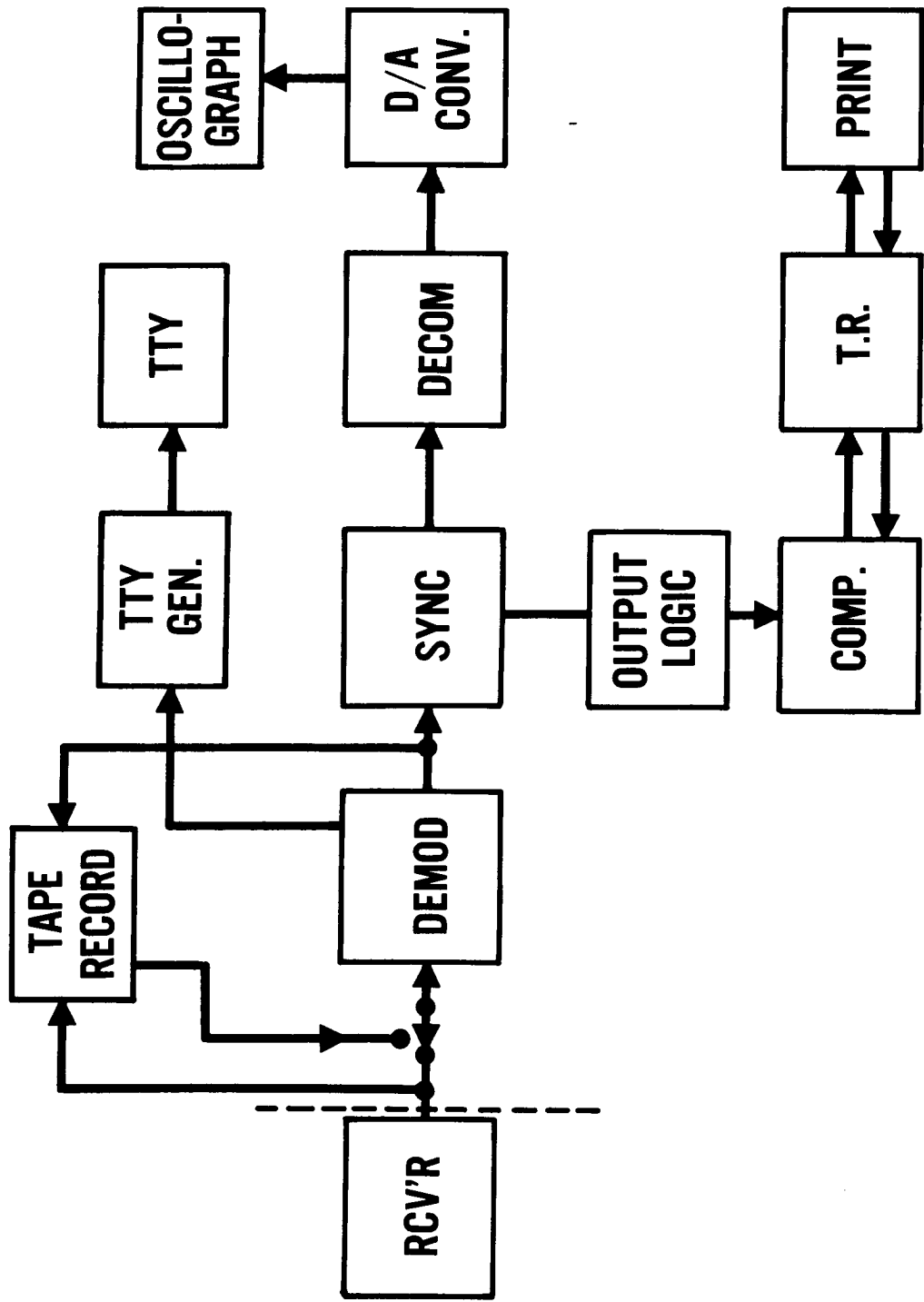

Figure 10 - Nimbus PCM Ground Station, Block Diagram