

204

No. 144-61

N63-12347

Code-1

PRIMARY COSMIC RAY AND SOLAR PROTONS II

PETER MEYER AND ROCHUS VOGT

UNPUBLISHED PRELIMINARY DATA

OTS PRICE

XEROX	\$	2.60
MICROFILM	\$	0.86



THE UNIVERSITY OF CHICAGO

THE ENRICO FERMI INSTITUTE FOR NUCLEAR STUDIES

EFINS-62-57

PRIMARY COSMIC RAY AND SOLAR PROTONS II *

Peter Meyer and Rochus Vogt[†]

Enrico Fermi Institute for Nuclear Studies and Department of Physics
University of Chicago, Chicago, Illinois

Submitted to

PHYSICAL REVIEW

December 1962

* This research was supported in part by the National Science Foundation, the National Aeronautics and Space Administration, the Office of Naval Research, USN, and the Office of Scientific Research, USAF.

[†] Present address: Norman Bridge Laboratory, California Institute of Technology, Pasadena, Cal.

PRIMARY COSMIC RAY AND SOLAR PROTONS II*

Peter Meyer and Rochus Vogt[†]

Enrico Fermi Institute for Nuclear Studies and Department of Physics
University of Chicago, Chicago, Illinois

Abstract

During July and August 1961 the energy spectrum of primary cosmic ray protons was investigated in the energy range from 80 to 350 Mev. The observations were made in five high altitude balloon flights at geomagnetic latitudes $\lambda \geq 73^\circ$ N. Solar flare and quiet day spectra were obtained. A comparison of the 1960 and 1961 results leads to the conclusions that, 1. A significant flux of low energy protons is continually present in the primary radiation in the years of high solar activity; 2. This flux decreases with the declining level of solar activity as the galactic cosmic ray flux increases. It is, therefore, suggested that it is of solar origin; 3. The time dependence of the observed proton flux suggests the following alternatives:

- a) The particles are produced or released more or less continuously by the sun and do not originate only in the large flare events; or
- b) The particles are produced in individual large solar flares and subsequently stored over long periods of time. This second alternative would require a new and as yet unknown storage mechanism with a characteristic time of about 30 or more days.

* This research was supported in part by the National Science Foundation, the National Aeronautics and Space Administration, the Office of Naval Research, USN, and the Office of Scientific Research, USAF.

[†] Present address: Norman Bridge Laboratory, California Institute of Technology, Pasadena, California.

I. Introduction

In an earlier paper¹ we have reported an investigation of the flux and energy spectrum of primary cosmic ray protons in the energy range from 80 to 350 Mev. This energy interval is of particular interest for two reasons:

1. Experiments have shown that solar processes which are capable of modulating the flux of cosmic rays of galactic origin strongly influence the low energy portion of the spectrum in the inner solar system. Current theories predict a very low flux below 500 Mev in the years near solar maximum.² Measurements of the flux and energy spectrum will, therefore, test these theories and yield information on the physical conditions prevailing in interplanetary space.

2. It is now known that the sun frequently emits protons with energies up to about 500 Mev in association with large solar flares. On rare occasions the energy of the emitted particles may go up to as high as 20 Bev. However, no evidence is available whether the large number of small flares which occur on the solar disk in the periods of enhanced solar activity contribute to the persistent flux of protons in the inner solar system.

The results of our earlier work,¹ which was carried out in 1960, not far from the maximum of solar activity, showed the continuous presence of a substantial flux of low energy protons with a spectral distribution that is radically different from predictions based on theoretical models for galactic particle modulation. Hence these results raised the question whether it is necessary to revise present ideas on the mechanism by which the sun modulates the flux of galactic particles or whether the low energy protons are accelerated within the solar system. The second alternative leads to the conclusion that either the sun itself is a more or less continuous injector of protons with energies ranging from about one hundred to

several hundred Mev, or that there exists a mechanism through which these particles may be stored in the solar system for extended periods of time after major solar flares.

In order to clarify these questions, we have continued our measurements of the proton flux and energy spectrum in the year 1961. In this paper we report experimental results from a series of balloon flights which we carried out during July and August 1961 from Ft. Churchill, Manitoba. The results from these additional experiments lead to conclusions regarding the origin of the primary cosmic ray protons in the energy range from 80 to 350 Mev near solar maximum.

2. The experiment

The equipment used to measure the flux and energy spectrum was almost identical to the one described earlier.¹ We used a counter telescope which selects particles incident from the vertical direction. The energy loss and the range in lead was measured simultaneously for each particle. These two measurements uniquely define the energy and the kind of each incident particle. We refer to our earlier paper for a full description of the instrument and its performance. A cross section of the apparatus is shown in Fig. 1. The following changes were made in the instrument:

1. We have added one additional range counter which is located directly below the NaI crystal in which the initial energy loss measurement is made. This counter helps to distinguish between particles stopping in the NaI crystal and those stopping in the first lead absorber.

2. The thickness of the NaI crystal above the lead absorber was reduced from 1/4" to 1/8".

3. We increased the area of the anticoincidence counters which surround the lead absorber by about 20%. This introduces an insignificant change in the correction of our data. We also analyzed all events in which any of the anticoincidence counters were triggered.

All balloon flights were carried out from Ft. Churchill, Manitoba at a geomagnetic latitude of 73° N. At no time did a balloon drift far enough south so that the geomagnetic cut-off could limit the acceptance of primary protons. The lowest energy that could be measured was determined by the residual atmosphere above the balloon gondola. Measurements were made on the following five days: July 22, July 29, Aug. 1, Aug. 6 and Aug. 8, 1961. The floating altitudes varied between 4.5 and 5 g/cm^2 of residual atmosphere.

3. Solar and Cosmic Ray Activity in the Period of the Experiment

At the time of our 1961 observations the general level of solar activity had substantially declined from its maximum in 1958. Average solar activity was below the 1960 level when our previous measurements were made and the quiet day galactic cosmic ray intensity at the earth was above the 1960 level (see Fig. 2).

However, some of our observations in July 1961 fell into the period when an active region (Mt. Wilson 15353) crossed the solar disc. This region, which passed central meridian on July 14, 1961,³ produced several large solar flares which were accompanied by the emission of intense fluxes of solar protons,^{4,5,6} polar cap absorptions,⁷ Forbush decreases and geomagnetic storms. In Fig. 3 we present some of the activity indices which are relevant to the discussion of our results. The figure includes the magnetic Kp indices, solar flare activity (compiled

from ref. 8) and the Chicago and Climax neutron monitor intensity as a function of time.⁶ The dates of our balloon measurements are indicated by arrows. We made our first observation of primary protons on July 22, several days after the class 3⁺ flares on July 18 and July 20, which emitted protons up to relativistic energies and were accompanied by wide band radio bursts.³ Obscured by the July 18 flare is the onset of a Forbush decrease, from which the high energy cosmic ray intensity level partially recovered on July 22. Another Forbush decrease occurred on July 27 together with the observation of large numbers of low energy solar protons,⁵ but no increase in the high energy range was observed. Our July 29 and Aug. 1 measurements took place during the recovery period of this Forbush decrease. On August 6 and August 8, the dates of our later observations, the neutron monitor levels were back to normal. A decrease in the intensity of cosmic radio noise (27.6 mc/sec) at College, Alaska⁷ was in progress from July 11 to July 28 with maxima on July 13-14, July 18, July 20 and July 26-27. This polar cap absorption is evidence for the presence of large fluxes of protons in the 10 Mev range.

4. Results and Discussion

In Table 1 we present the results on the primary proton flux which were obtained during July and August 1961. The flux values are averages over the hours of observation. We observed no intensity variations during any of the flights except on July 22, which showed a slow decrease of the particle flux between 80 and 350 Mev. This variation represents the decline in intensity of stored solar flare particles (class 3⁺ flare July 18 and July 20). The flux values shown in

Table 1 are corrected for secondaries and nuclear interactions and are extrapolated to 0 g/cm^2 atmospheric depth using the procedures which were described in ref. (1). We also show in Table 1 the uncorrected data with their statistical error. These data can be used in obtaining the relative changes in intensity between measurements carried out at different times.

The differential energy spectra of primary protons are shown in Fig. 4. In the following we shall discuss these results.

a) Solar flare events

The differential energy spectrum of July 22 is well represented by a power law with an exponent $\gamma = 4$. This spectral shape is frequently observed in the declining phase of a large solar proton event. Below 200 Mev the proton flux on July 22 consists almost entirely of solar flare particles. The subtraction of the quiet day flux would not substantially change the spectrum. On July 29 (Fig. 4b) the proton flux below 190 Mev is enhanced above the quiet day level, which was later observed. The additional low energy protons do not necessarily represent the tail of the July 18 and July 20 events. Firstly, a low energy solar proton event was seen on July 26 - 27,⁵ and secondly, a Forbush decrease had taken place on July 27 (Fig. 3). This Forbush decrease caused a reduction in flux of 22% in the energy region from 190 to 350 Mev and of 4.7% in the energy region above 350 Mev on July 29. This behavior is in qualitative agreement with the expected rigidity dependence of Forbush decreases.⁹

Since on July 22 we also measured the energy spectrum and flux of solar electrons¹⁰ we are able to determine the electron to proton ratio for certain rigidity or energy intervals. For rigidities above 350 MV we find 3 electrons per

100 protons and for energies above 80 Mev we find 20 electrons per 100 protons in the beam of solar particles. We believe it would be difficult to arrive at conclusions regarding the solar acceleration mechanism on the basis of these numbers since entirely different deceleration processes affect the two kinds of particles in their escape from the sun.

b) Short term changes of the proton flux and the energy spectrum

From August 1 through August 8 no significant change of the primary proton spectrum was observed (see Fig. 4c,d,e). The comparison of our August 8 spectrum with a measurement on August 18 by Bryant et al,¹¹ in the same energy range leads to the conclusion that no significant changes took place over even longer periods of time. To further illustrate this point we show in Fig. 5 the time dependence of the proton flux for three energy intervals. The absence of any further decrease in intensity after August 1 demonstrates that the remaining low energy protons may not be considered a residue of the previous large flares which was stored throughout the solar system by the established storage mechanism with a characteristic time of a few days. If storage of flare particles is responsible for the persistent flux of low energy protons, the storage mechanism must have a characteristic time of the order of 30 days or more to be compatible with the experimental data. This question will be discussed further in section d.

The shape of the quiet day primary proton spectrum below 100 Mev has not yet been accessible to observation. We wish to note, however, that the lowest energy point in Fig. 4c,d,e falls consistently below the extrapolated power law spectrum. This suggests that the intensity of protons below 100 MeV does not follow the power law but is significantly lower.

c) Long term changes of the proton flux and energy spectrum

Observations of the spectrum and flux of the low energy primary protons over periods of time when significant changes in the general level of solar activity take place will yield information on the origin of those particles. One has to make sure, however, that the measurements used for comparison are representative of the quiet day flux and are not influenced by individual solar events. During both periods of observation (1960 and 1961) the quiet day spectrum was occasionally affected by particle emission of large solar flares. For both years, however, we were able to obtain spectra which we consider typical for the quiet day condition. For the 1960 data we arrived at this conclusion through a careful study of the results of the balloon monitoring program of the University of Minnesota group¹² and of solar and polar cap absorption data.¹³ Both these observations show that for several weeks prior to August 22, 1960 no large solar flare event with associated particle injection occurred. While the measurement of the spectrum which we made on September 15, 1960 (see ref. 1) could be influenced by protons which were emitted by the class 3⁺ flare of September 3, 1960, the measurement of August 22, 1960 was not preceded by a large solar flare. Since the two spectra were identical and no intensity decrease could be detected during the 10-hour measurement on either day, we consider them typical for the quiet day condition. Similar arguments for the 1961 measurements were given in sections 4a and b.

Substantial changes in the primary proton spectrum were observed between 1960 and 1961 (see Fig. 6). First, the intensity of protons with energies larger than 350 Mev has increased by $(10 \pm 3)\%$ in 1961. The differential spectrum in this energy interval cannot be obtained from our measurement. The curves in

Fig. 6 are tentative extrapolations based on arguments given in ref. 1. This behavior is in agreement with earlier observations¹⁴ and predictions by theoretical models for the solar modulation of galactic cosmic rays. In the energy interval from 190 to 350 Mev we also observe an increase which amounts to $(7+5)\%$. The flux of protons below 190 Mev shows a totally different behavior. In 1961 the proton intensity between 80 and 190 Mev is about 65% of the 1960 value. The observed increase in galactic proton intensity concurrent with the decrease in the low energy proton flux leads to the conclusion that two independent mechanisms are responsible for the changes in the primary proton spectrum.

d) The origin of the low energy primary protons

The observations which we described in the preceding paragraphs enable us to decide between galactic versus solar origin for the low energy protons. In the energy region above 200 Mev solar modulation of galactic particles is the dominating process which produces the observed changes. The fact that below 200 Mev the proton intensity decreases with declining solar activity lets us conclude that most of these particles are accelerated by the sun. In the previous discussion we have shown that individual large flares cannot be responsible for the continuous presence of the low energy protons, unless there exists a storage mechanism which is capable of retaining a fraction of these particles in the solar system for extended periods of time. The same arguments apply to the possibility that large flares on the back side of the sun may be the source of the low energy protons, since intensity variations within a day and over several weeks were absent in our observations. We, therefore, propose that the low energy protons are either continuously or very frequently emitted by the sun or are evidence for long term particle storage

in the solar system. We have shown before¹ that the energy required for solar production of these particles is very small in terms of the total energy output of the sun.

5. Summary

In the years 1960 and 1961 we have investigated the differential energy spectrum of primary cosmic ray protons in the energy range from 80 to 350 Mev. We also have measured the integral proton flux for higher energies. The results obtained in 1960 are discussed in ref. 1. Five balloon flights were carried out from Ft. Churchill, Manitoba in July and August 1961. A part of these observations was made shortly after the occurrence of two class 3⁺ solar flares. The later flights took place at a time of quiet solar conditions. We have obtained the following results:

1. The solar flare proton spectrum which was observed on July 22, 1961 was of the form

$$\frac{dJ}{dE} = 4.6 \times 10^9 E^{-4} \text{ (protons/m}^2 \text{ sec sr Mev)}$$

2. A study of the time dependence of the low energy proton flux and energy spectrum after August 1, 1961 shows that these particles cannot be the residue of any preceding large solar flare, unless one invokes the existence of a new long term storage mechanism in the solar system, which has a characteristic time of about 30 days or more.

3. A comparison of the results obtained in 1960 and 1961 demonstrates the continuous presence of a significant flux of primary protons with energies down to 80 Mev and a spectrum which rises toward lower energy. There is an

indication for a flattening of the spectrum below 100 Mev. Significant changes in the spectral distribution of the protons were observed between the two years of measurement. The flux above 200 Mev increased with time as a result of decreasing efficiency of solar modulation. In the same time interval the proton flux below 200 Mev decreased. We interpret this result as evidence for the solar origin of the low energy protons. These protons must be either produced or released continuously or very frequently by the sun, or, if they are injected during large solar flares, they must have been stored in the solar system for extended periods of time.

We are indebted to T. Burdick who constructed the electronics system and was of invaluable assistance during all balloon flights. We wish to thank many individuals for their contributions to this work: J. Vesel assisted in the field operation, R. Tjonaman was responsible for the neutron monitor data, G. Lentz prepared the computer program, Miss J. Janto, J. L'Heureux and R. Eckstrom helped with the data reduction, W. Mankovich, A. Hoteko and S. Avery took care of special engineering tasks, L. Littleton constructed the pressure indicators. We are grateful to R. Keuser and the team of Raven Industries for providing us with five successful balloon flights. It is a pleasure to acknowledge the excellent support given to us by the Skyhook program of ONR, USN, the U. S. Army and the Royal Canadian Air Force at Ft. Churchill.

References:

1. R. Vogt, Phys. Rev. 125, 366 (1962).
2. See for ex. E. N. Parker, Phys. Rev. 110, 1445 (1958) and Astrophys. J. 133, 1014 (1962).
3. M. A. Ellison, S. M. P. McKenna and J. H. Reid (Preprint 1962).
4. H. Carmichael and J. F. Steljes, Journ. Phys. Soc. Japan 17, Suppl. A-II, 337 (1962).
5. B. Maehlum and B. J. O'Brien, Journ. Geophys. Res. 67, 3269 (1962).
6. The Climax and Chicago neutron monitor data are due to Dr. J. A. Simpson.
7. H. Leinbach, High Latitude Geophysical Data, UAG-C23, Univ. of Alaska (1961).
8. Solar-Geophysical Data, Part B, CRPL, Boulder, Colorado.
9. E. N. Parker, Journ. Phys. Soc. Japan 17, Suppl. A-II, 563 (1962).
10. P. Meyer and R. Vogt, Phys. Rev. Letters 8, 387 (1962).
11. Bryant, Cline, Desai and McDonald, Journ. Geophys. Res. (To be published).
12. We wish to thank Dr. J. R. Winckler for making his original data available to us.
13. This information was kindly supplied by H. Leinbach.
14. F. B. McDonald and W. Webber, Phys. Rev. 115, 194 (1959).

Table 1: Measurements of average proton flux on July 22, July 29, August 1, August 6 and August 8, 1961, for various energy intervals

Kinetic energy of primary protons at 0 g/cm ²	80 < E < 190 Mev		190 < E < 350 Mev		E > 350 Mev	
	Measured Flux ^a	Corrected Flux ^b	Measured Flux ^a	Corrected Flux ^b	Measured Flux ^a	Corrected Flux ^b
Date and time of observation	Vertically incident protons / m ² sec sr					
July 22, 1962 1100 - 1300 UT	2167 ± 42	2110 ± 42	147 ± 10	165 ± 14	726 ± 22	1062 ± 120
July 29, 1962 1000 - 2000 UT	143 ± 7	119 ± 7	72 ± 3	78 ± 4	757 ± 10	1172 ± 140
August 1, 1961 1200 - 2200 UT	129 ± 5	105 ± 6	81 ± 4	92 ± 6	777 ± 12	1204 ± 145
August 6, 1961 0700 - 1200 UT	122 ± 5	80 ± 5	-	-	855 ± 17	1324 ± 185
August 8, 1961 1200 - 2100 UT	122 ± 4	90 ± 6	93 ± 4	99 ± 5	822 ± 12	1263 ± 150

^a Errors given are statistical

^b Errors given are statistical plus systematic, corrections include nuclear interactions in lead absorber and contribution from atmospheric secondaries.

Figure Captions

- Fig. 1. Cross section of the detector system for the 1961 measurements.
- Fig. 2. Monthly average of the Climax neutron monitor intensity 1954-1962.
- Fig. 3. Daily averages of the Climax neutron monitor intensity, solar flare and geomagnetic activity during the period of the balloon measurements.
- Fig. 4. Primary proton energy spectra at 0 g/cm^2 on July 22 (a), July 29 (b), Aug. 1 (c), Aug. 6 (d) and Aug. 8 (e) 1961. Values observed by Bryant et al¹¹ on Aug. 18, 1961 are included in (e).
- Fig. 5. The primary proton flux at 0 g/cm^2 as a function of time for three energy intervals during July and August 1961.
- Fig. 6. The primary proton energy spectrum in Sept. 1960 and August 1961. The extrapolation to high energies is based on the measured integral flux for $E \geq 350 \text{ Mev}$.

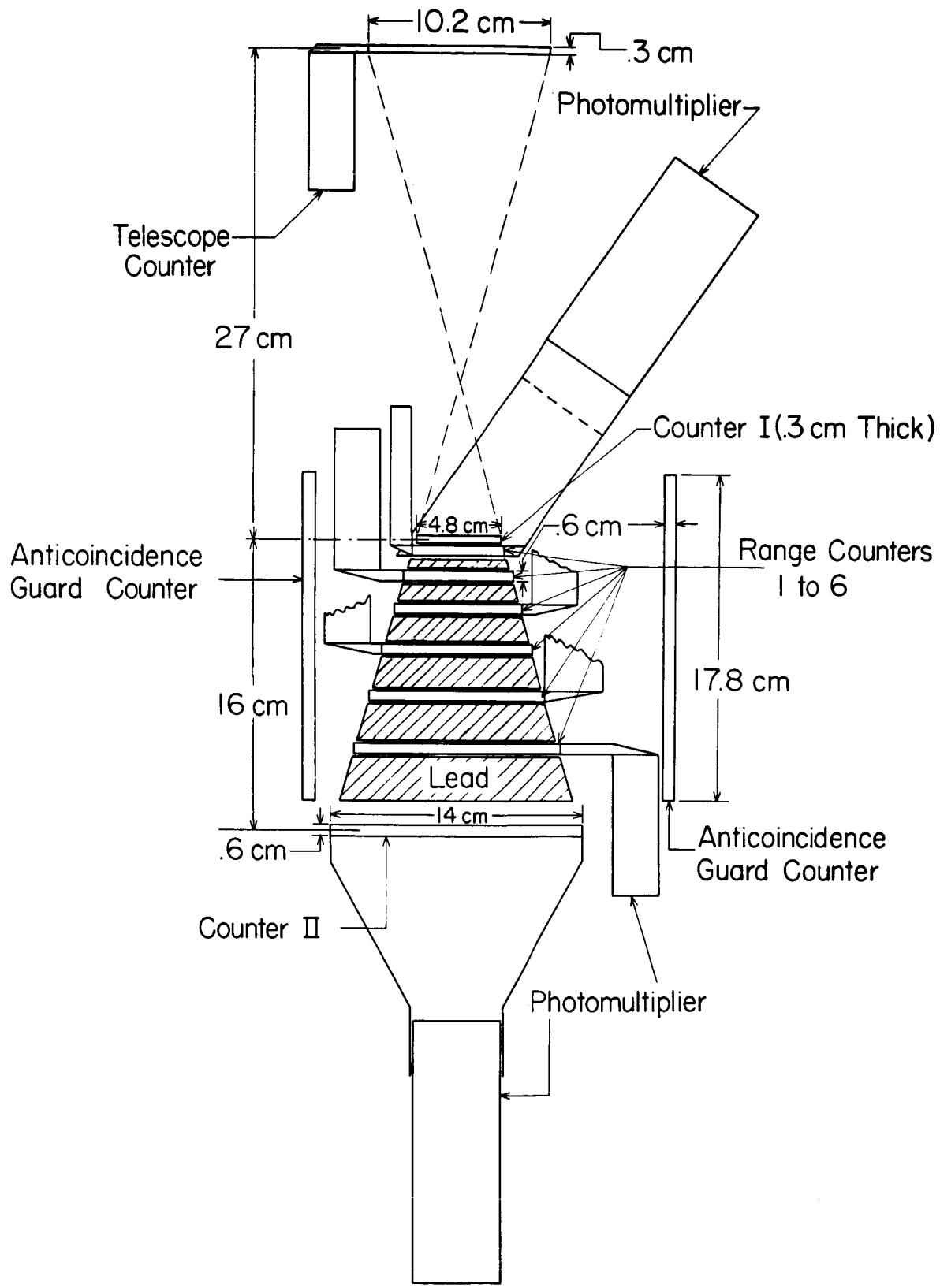

Fig.1

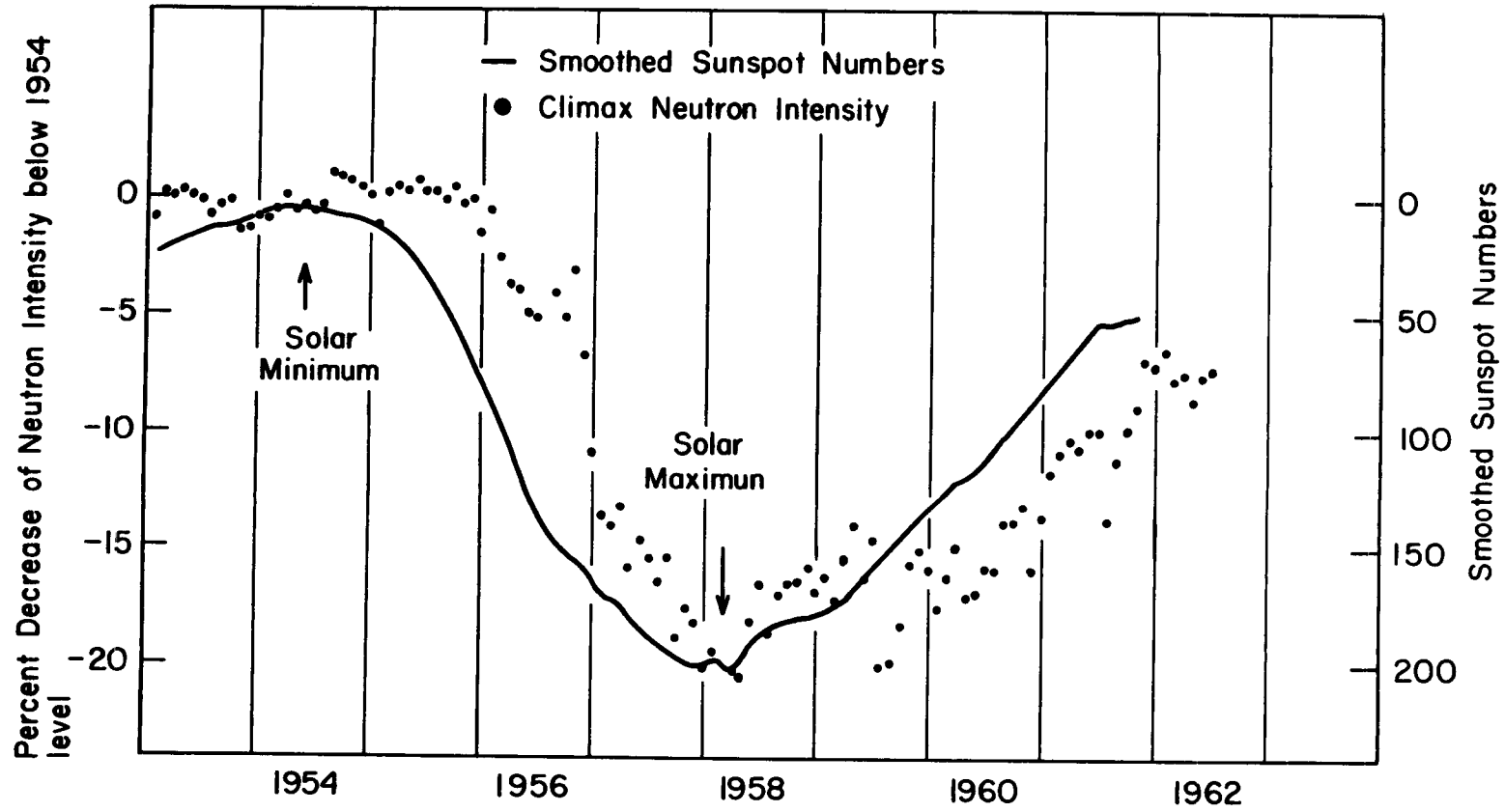

Fig. 2

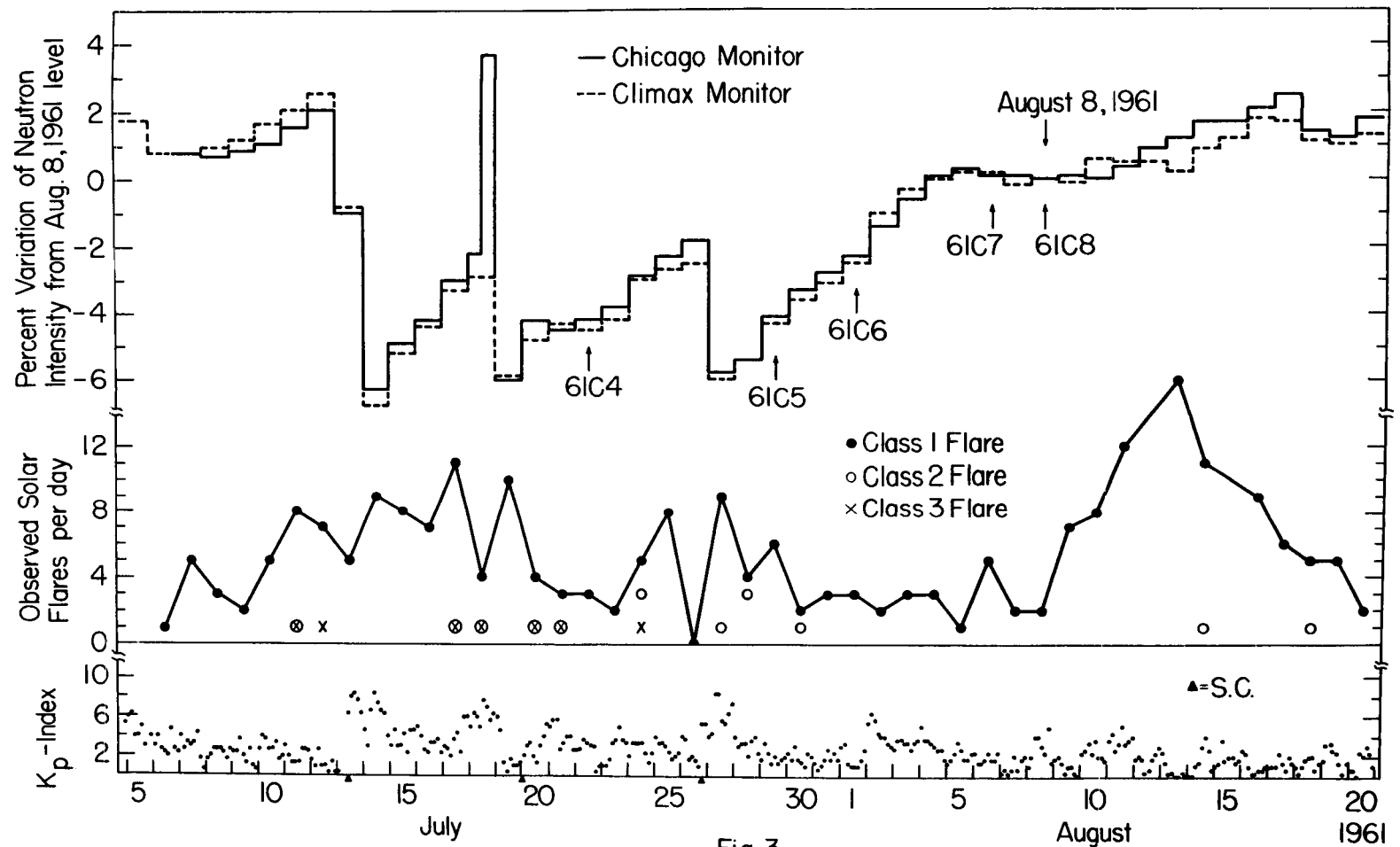

Fig. 3

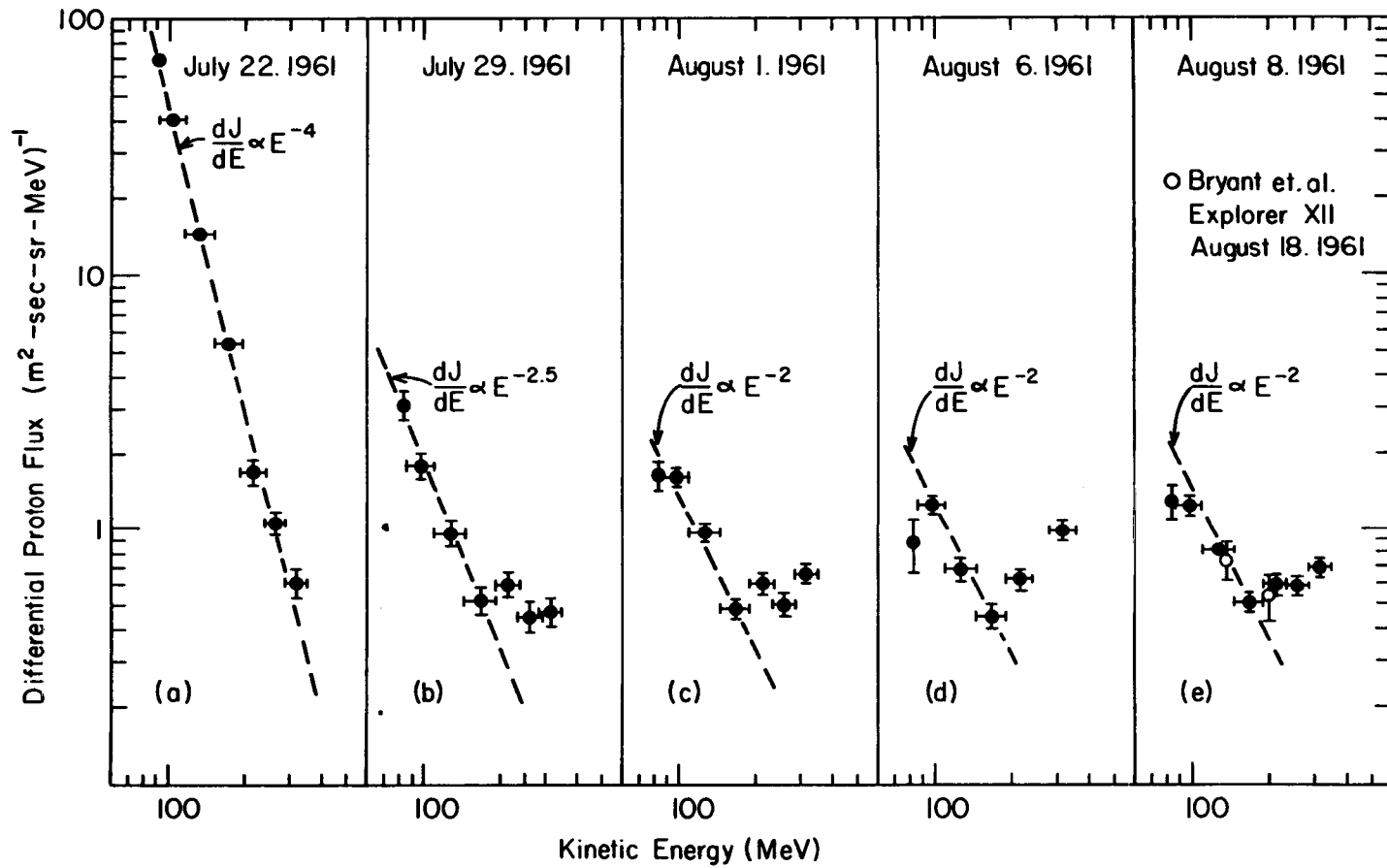

Fig. 4

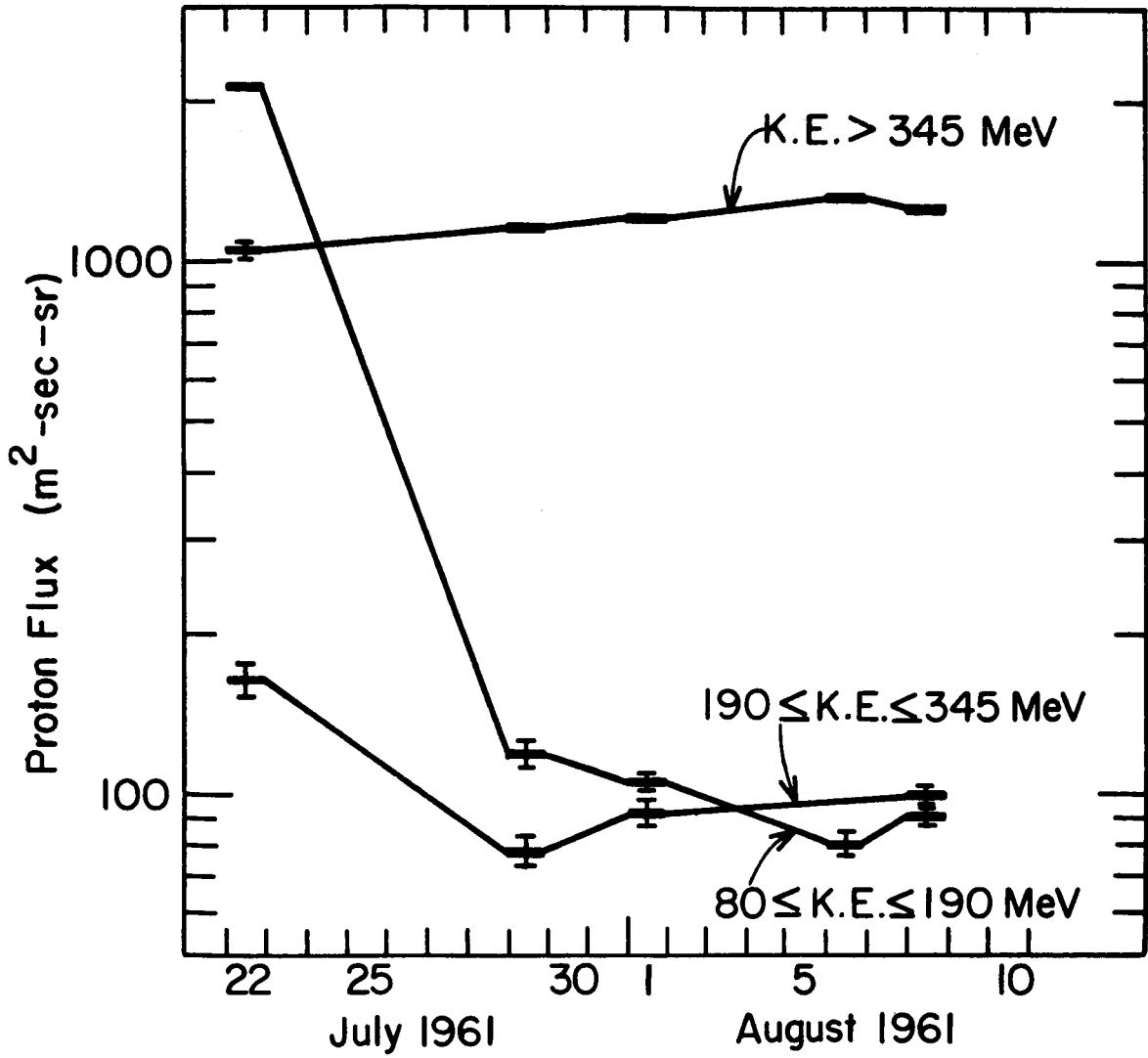

Fig.5

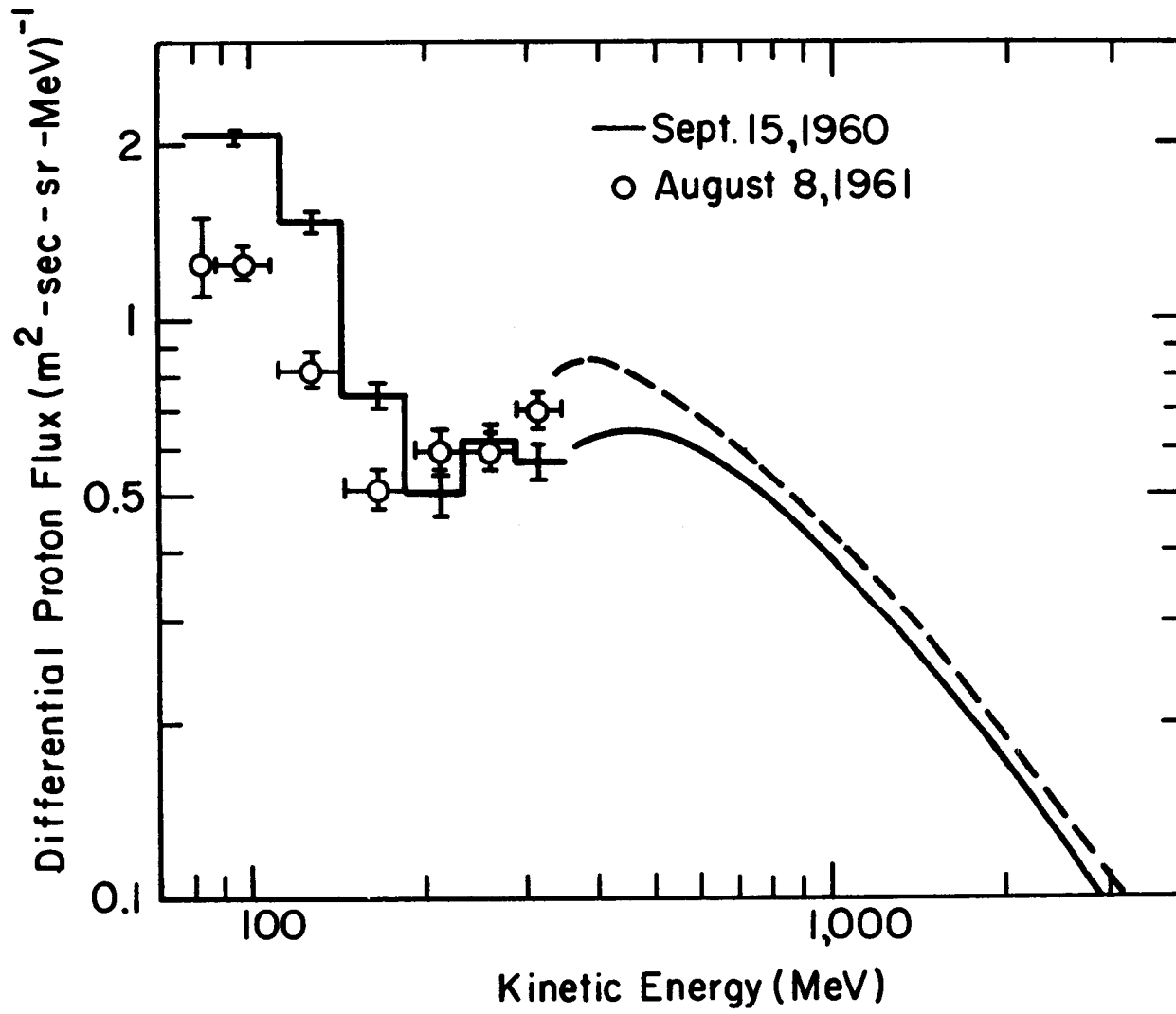

Fig. 6