

May 1964

Brief 63-10479

NASA TECH BRIEF



This NASA Tech Brief is issued by the Technology Utilization Division to acquaint industry with the technical content of an innovation derived from the NASA space program.

Improved Molybdenum Disulfide-Silver Motor Brushes Have Extended Life

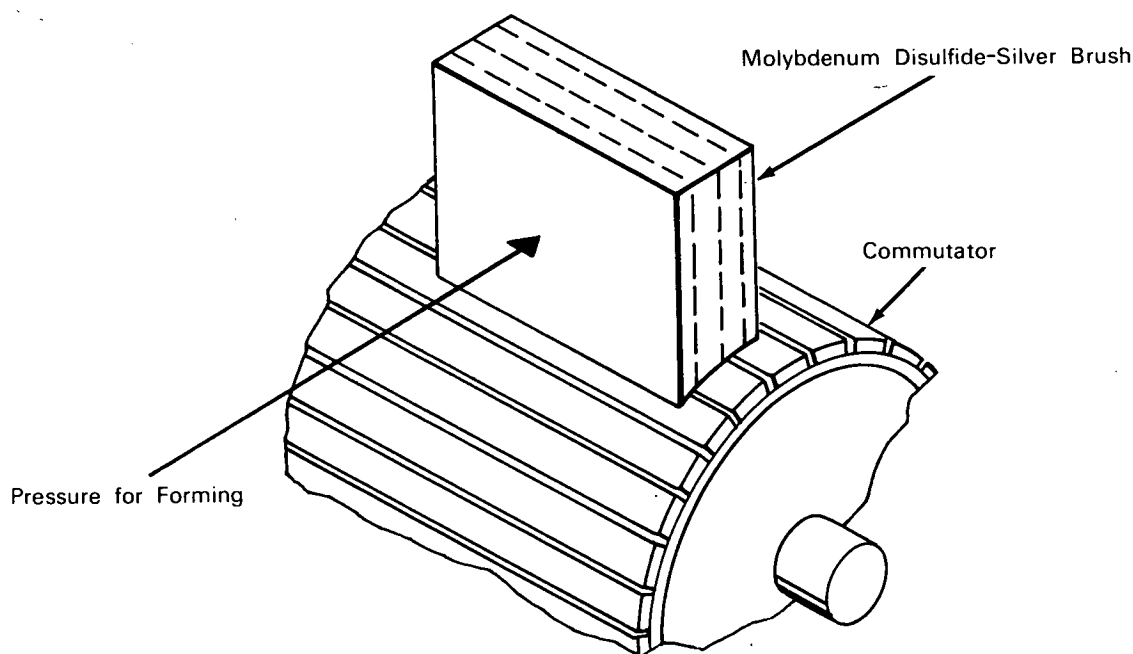

The problem: To develop a motor or generator brush material that will perform satisfactorily for extended periods in either normal atmosphere or the high vacuum of space. Studies of various brush compositions indicate that sintered brushes composed of molybdenum disulfide and metallic copper or silver can be operated in a high-vacuum environment for periods much greater than conventional high-altitude barium fluoride-graphite brushes. However, many combinations of molybdenum disulfide and copper or silver exhibit sufficient heating characteristics to cause difficulty in the standard spring and holder.

The solution: A motor brush composed of 90% molybdenum disulfide and 10% copper, or 86% molybdenum disulfide and 14% silver.

How it's done: These brushes are manufactured by conventional sintering techniques. Proper quantities of molybdenum disulfide and copper, or silver are placed in a graphite mold and raised to a temperature of 1,600 to 1,700°F while being held under 3,500 p.s.i. plunger pressure. When the maximum desired temperature has been reached, the molds are removed from the furnace and the brushes are allowed to cool. Optimum operating characteristics are ob-

(continued overleaf)

tained when molding pressure has been applied in a direction perpendicular to a plane formed by the longitudinal axis of the commutator and a radial through the centerline of the brush.

Notes:

1. Brushes made from these compositions have run in excess of 1,500 hours at 3,000 r.p.m. and brush current of 0.3 amp in an environmental pressure of 10^{-7} torr without serious heat generation. Observed wear rate is 0.1 that of high-altitude brushes, and 0.01 to 0.001 that of conventional graphite brushes.
2. Molybdenum disulfide-silver brushes can be used effectively in all applications where long wearing qualities are desired or high-altitude requirements exist.

3. For further information about this innovation inquiries may be directed to:

Technology Utilization Officer
Marshall Space Flight Center
Huntsville, Alabama 35812
Reference: B63-10479

Patent status: NASA encourages the immediate commercial use of this invention. It is owned by NASA, and a patent application has been filed. When patented, royalty-free nonexclusive licenses for its commercial use will be available. Inquiries concerning license rights should be made to NASA Headquarters, Washington, D.C. 20546.

Source: J.C. Horton and H. M. King
(M-FS-64)