

March 1964

Brief 63-10435

# NASA TECH BRIEF



This NASA Tech Brief is issued by the Technology Utilization Division to acquaint industry with the technical content of an innovation derived from the NASA space program.

## Portable Display Paneling Has Wide Use, Easy Take Down and Assembly

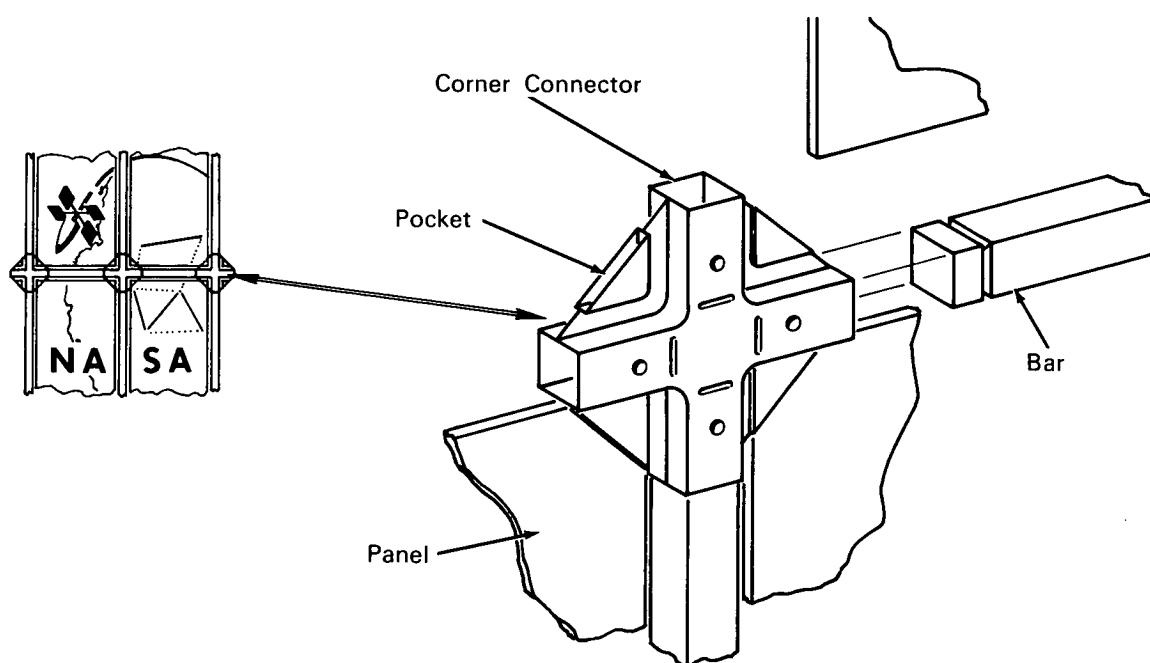

**The problem:** Design of portable display paneling that is sturdy and yet can be taken down easily or reassembled. Completed display must be attractive and moderate in cost.

**The solution:** A modular display panel based on a cross-shaped corner connector and wooden lattice bars.

**How it's done:** The key element in this panel is the metal corner connector. For this application it is made of two metal stampings so designed that two identical pieces can be spot welded together to form the connector. Other joining methods, such as bolting or riveting, can be employed.

Form of the completed connector is a right-angled cross. Arms of the cross are hollow and square in cross-section so that a square wooden lattice bar will fit into each arm. A circular detent serves to secure the bar while an elongated detent acts as a stop. In the web between two adjacent arms there is a pocket slot to hold a modular-size panel. The display is constructed by putting the required number of bars and panels together.

Variations in size, shape and choice of materials can be made to suit specific displays. Design is such that displays can be curved if desired. Other important features are: low cost, sturdiness, and ease of rapid assembly and disassembly.

(continued overleaf)

**Notes:**

1. This is a highly practical approach to the problem of large display panels. It could be useful to advertising firms, manufacturers who require displays at trade shows or other places, and research organizations.
2. Because of the ease of take-down, this display greatly simplifies the problems of transportation and storage. Space required is much less and only simple packing crates are needed.

3. Display designers will have more flexibility in planning a layout. An alternate presentation, for example, can be put on the back of the modular panels. Position of the panels can be changed so that a display could offer a change in appearance if moved from one location to another.

**Patent status:** NASA encourages commercial use of this innovation. No patent action is contemplated.

Source: H. J. DeVoto  
Ames Research Center (ARC-17)