

NASA TECH BRIEF

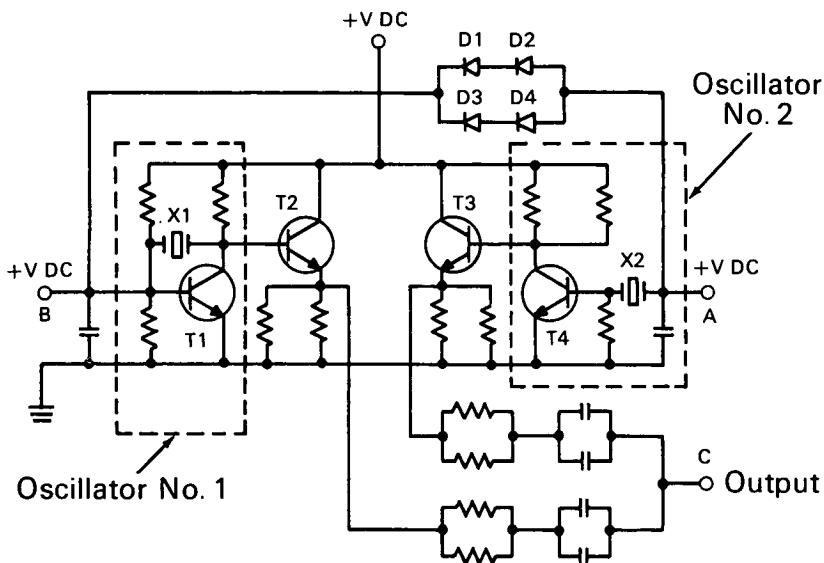

This NASA Tech Brief is issued by the Technology Utilization Division to acquaint industry with the technical content of an innovation derived from the NASA space program.

Increased Performance Reliability Obtained with Dual (Redundant) Oscillator System



The problem: To design an oscillator circuit having a high performance reliability with respect to output frequency and amplitude.

The solution: Two crystal-controlled oscillators, each with an associated buffer stage, for providing an output at a common point.

How it's done: The two oscillators No. 1 and No. 2 (including transistors T1 and T4), each with an associated buffer stage (including transistors T2 and T3), provide an output at a common point C. The output of the system will be at the selected frequency even when either one of the oscillators is not operative. To avoid the problem of synchronizing the outputs of the two oscillators at point C, the amplitude of oscillation of oscillator No. 2 is kept at a very low level by the clamping action of diodes D1-D4. When the tran-

sistor T1 of oscillator No. 1 is cooperating with crystal X1, the related feedback circuitry provides an output of proper frequency and amplitude at point C. Whenever oscillator No. 1 varies from its normal operating condition, oscillator No. 2 ceases to be clamped to a low level and takes over to provide the proper output at point C. The bias voltage at point A must be slightly positive with respect to that at point B to assure that the clamping diodes D1-D4 are normally biased to conduction.

Patent status: NASA encourages commercial use of this innovation. No patent action is contemplated.

Source: W. M. Nolis, International Business Machines under contract to Goddard Space Flight Center (GSFC-36)