

# Production System Improvement: Floor Area Reduction and Visual Management

By  
Zhuling Chen

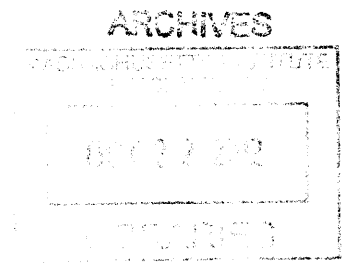
B.Eng. Chemical and Biomolecular Engineering, Nanyang Technological University, 2011

Submitted to the Department of Mechanical Engineering  
In partial fulfillment of the requirements for the degree of  
Master of Engineering in Manufacturing

at the  
MASSACHUSETTS INSTITUTE OF TECHNOLOGY

September 2012

© Massachusetts Institute of Technology, 2012. All rights reserved.



Signature of Author: \_\_\_\_\_  
Department of Mechanical Engineering  
August 9, 2012

Certified by: \_\_\_\_\_  
Stephen C. Graves  
Abraham J. Siegel Professor of Operations Management  
Thesis Supervisor

Accepted by: \_\_\_\_\_  
David E. Hardt  
Ralph E. and Eloise F. Cross Professor of Mechanical Engineering  
Chairman, Committee for Graduate Students

# **Production System Improvement: Floor Area Reduction and Visual Management**

By

Zhuling Chen

Submitted to the Department of Mechanical Engineering

On 08 August 2012, in partial fulfillment of

the requirements for the degrees of Master of Engineering in Manufacturing

## **Abstract**

This thesis suggests on the development process of a new layout design and visual management tools to improve the efficiency of a production line in a medical device company. Lean production philosophy and common lean techniques were adopted as a guideline in this project.

A new layout design was proposed to utilize less manufacturing space while maintaining or improving the current production rate. A thorough study of the current system was conducted and preliminary analysis on the current system efficiency was evaluated. Design concepts were generated based on major reduction opportunities, namely removal of non-production areas on the floor, a point of use inventory system, consolidation of equipment and benches, new bench configuration. The final layout design reduced 479 ft<sup>2</sup> from the original layout with the same production rate.

Visual management tools were developed after identifying key performance indicators for the production line. The visual management tools presented important data in a comprehensive way, facilitated communication among the production team and management team and empowered production associates in making continuous improvement on the floor.

**Key Words:** Lean Manufacturing, Floor Area Reduction, Visual Management, Key Performance Indicators, System Efficiency

**Thesis Supervisor:** Stephen C. Graves

**Title:** Abraham J. Siegel Professor of Management Science, Professor of Mechanical Engineering and Engineering Systems

## **Acknowledgement**

I would like to express my gratitude to my thesis advisor, Professor Stephen C. Graves, for providing me valuable and insightful advices during this project. His comments and guidance helped me to have the right focus and approaches to complete this thesis.

I am also grateful to Professor David E. Hardt and Dr. Brian W. Anthony for their efforts to establish and run the Master of Engineering in Manufacturing Program. It was a great experience for me and has enriched my life in so many aspects.

I would like to thank the people I worked with in the company for their support and friendliness. They have made this project possible and I enjoyed every day of work.

Thanks go to all MIT professors involved in teaching in this program. Their knowledge and passion in teaching has inspired me to find my direction for the future and share knowledge with others.

Special thanks to Ms. Jennifer L. Craig for reviewing this thesis and providing valuable technical writing advices and comments.

I would like to thank my project teammates for their excellent contribution and team spirit. They have made this project both fruitful and memorable.

Last but not least, thanks to my parents and friends for their support and encouragement to make my study at MIT a great experience.

# Table of Contents

<b>1. Introduction.....</b>	<b>10</b>
<b>1.1 Motivation.....</b>	<b>10</b>
<b>1.2 Thesis Organization.....</b>	<b>11</b>
<b>2. Problem Statement.....</b>	<b>12</b>
<b>2.1 Problem Identification.....</b>	<b>12</b>
<b>2.2 Project Scope.....</b>	<b>12</b>
<b>2.3 Other Concentrations.....</b>	<b>13</b>
<b>3. Methodology.....</b>	<b>15</b>
<b>3.1 New Floor Layout Design.....</b>	<b>15</b>
3.1.1 Defining Goals.....	15
3.1.2 Capturing the Current State.....	16
3.1.3 Analyzing the Current State.....	16
3.1.4 Designing Proposals.....	16
3.1.5 Reviewing Proposals.....	17
3.1.6 Improving Proposals.....	17
<b>3.2 Visual management.....</b>	<b>17</b>
3.2.1 Defining Goals.....	17
3.2.2 Capturing the Current State.....	17
3.2.3 Analyzing the Current State.....	17
3.2.4 Designing Proposals.....	17
3.2.5 Reviewing Proposals.....	18
3.2.6 Improving Proposals.....	18
<b>4. Literature Review.....</b>	<b>19</b>
<b>4.1 Lean manufacturing.....</b>	<b>19</b>
<b>4.2 Six Sigma.....</b>	<b>21</b>
<b>4.3 DMAIC.....</b>	<b>21</b>
<b>4.4 Lean Sigma.....</b>	<b>22</b>
<b>4.5 Concerns about Lean Six Sigma Approaches.....</b>	<b>22</b>
<b>4.6 Lean Sigma at the company.....</b>	<b>23</b>



<b>4.7 Visual Management</b> .....	<b>24</b>
4.7.1 Defining System Performance .....	24
4.7.2 Key Performance Indicators .....	25
4.7.3 Designing Metrics .....	25
4.7.4 Applications of Visual Management .....	27
<b>5. Current Production System</b> .....	<b>29</b>
<b>5.1 The Product</b> .....	<b>29</b>
<b>5.2 Current Manufacturing Operations</b> .....	<b>29</b>
5.2.1 Catheter Subassembly .....	30
5.2.2 The Accessory Subassembly .....	31
5.2.3 The Syringe Subassembly .....	32
5.2.4 Sheath Subassembly .....	33
5.2.5 Supermarket .....	33
5.2.6 Other areas .....	34
<b>5.3 Summary of Current Production System</b> .....	<b>35</b>
<b>6. Preliminary Analysis</b> .....	<b>36</b>
<b>6.1 Bench Numbering System</b> .....	<b>36</b>
<b>6.2 Overall Information and Material Flow</b> .....	<b>37</b>
<b>6.3 Product family matrix</b> .....	<b>39</b>
<b>6.4 Modeling:</b> .....	<b>41</b>
<b>7. Development of New Floor Layout</b> .....	<b>44</b>
<b>7.1 Major opportunities for floor reduction</b> .....	<b>44</b>
7.1.1 Removing non-production areas/objects .....	44
7.1.2 Decentralizing inventory to point of use .....	46
7.1.3 Consolidating equipment and shortening benches .....	48
7.1.4 Change bench configuration .....	49
<b>7.2 Brainstorming different layouts</b> .....	<b>49</b>
7.2.1 Proposals .....	49
<b>7.3 New Layout Evaluation Metrics</b> .....	<b>51</b>
<b>7.4 Evaluation of new layout designs</b> .....	<b>52</b>
<b>7.5 Layout Selection</b> .....	<b>53</b>

<b>7.6 Improvement of the Final Layout Design.....</b>	<b>54</b>
7.6.1 Iteration one.....	54
7.6.2 Iteration two .....	54
7.6.3 Iteration three.....	54
<b>7.7 Implementation Package .....</b>	<b>55</b>
<b>8. Development of Visual Management .....</b>	<b>56</b>
<b>8.1 Identification of Key Performance Indicators .....</b>	<b>56</b>
8.1.1 Key Stakeholders Identification.....	56
8.1.2 Company’s Engagement.....	57
8.1.3 Key Performance Indicators .....	58
<b>8.2 Design of Inventory Replenishment Management tool.....</b>	<b>60</b>
<b>8.3 Design of Kaizen Tool .....</b>	<b>62</b>
<b>8.4 Design of Production Performance Tool.....</b>	<b>64</b>
<b>9. Conclusions and Future Work.....</b>	<b>66</b>
9.1 Conclusions.....	66
9.2 Lesson Learned .....	66
9.3 Recommendations for the Company.....	67
9.4 Future Work .....	68
<b>REFERENCES.....</b>	<b>69</b>
<b>APPENDIX .....</b>	<b>71</b>

# List of Tables

- Figure 1: The Five Projects to Improve System Efficiency ..... 11
- Figure 2: High Level Overview of Methodology ..... 15
- Figure 3: Roadmap of DMAIC..... 22
- Figure 4: From Normal to Lean to Lean Sigma ..... 23
- Figure 5: Overview of the Current Floor Layout..... 30
- Figure 6: Catheter Subassembly..... 31
- Figure 7: The Accessory Subassembly..... 32
- Figure 8: The Syringe Subassembly ..... 32
- Figure 9: The Sheath Subassembly..... 33
- Figure 10: The Supermarket Areas..... 34
- Figure 11: Other Areas ..... 34
- Figure 12: Top view of the Current Occlusion System Floor with Bench Labeling ..... 37
- Figure 13: Schematic Diagram of Information and Material Flow ..... 38
- Figure 14: Floor area and boundary Model ..... 41
- Figure 15: Generic table model..... 42
- Figure 16: Fume hood model ..... 42
- Figure 17: Supermarket Model ..... 43
- Figure 18: Original layout model..... 43
- Figure 19: Centralized Supermarket on the Floor..... 47
- Figure 20: Design Proposals, from left to right, top to bottom,..... 50
- Figure 21: Saved Area Utilization for Design A..... 53
- Figure 22: Template of Raw Material Replenishment Tool..... 61
- Figure 23: Generic example of Kaizen Tool ..... 63
- Figure 24: Production Performance Tool ..... 65

Figure 25: An Example of a Weekly Cumulative Production Chart ..... 65

Figure 26: Current Floor Layout with Major Dimensions ..... 75

Figure 27: Proposed Floor Layout with Major Dimensions ..... 76

# List of Tables

Table 1: University of California Performance Measures [21] ..... 27

Table 2: Summary of Floor Layout for each Subassembly ..... 35

Table 3: Summary of Equipment on Each Subassembly ..... 40

Table 4: Summary of Number of Items in Each Category ..... 45

Table 5: Family Product Matrix ..... 48

Table 6: Summary of Designs based on Evaluation Metrics ..... 53

Table 7: Key Performance Indicators Identified in this project ..... 58

Table 8: Changes on Affected Benches ..... 77

Table 9: Parts to be provided ..... 83

# 1. Introduction

This thesis was prepared in partial fulfillment of the requirements for the degree of Master of Engineering in Manufacturing at the Massachusetts Institute of Technology (MIT). It is based on a three-month group project at a medical devices company aiming to achieve certain objectives that will help to enhance the manufacturing process of one of its products. As per the signed Non Disclosure Agreement, the company, products, subassemblies, procedure names and codes will be either kept anonymous or given different names.

## 1.1 Motivation

In this project, lean production techniques were adopted to improve the efficiency of the production system in a medical device company. Five aspects of the system were studied to develop a new system proposal with higher efficiency. The current production floor layout was revised and new design was proposed to reduce the production space needed while maintaining the production rate. Visual management system was tailored to facilitate information flow from the production floor to management team to monitor production activities and address anomalies in a proactive manner. The impact of different layout on cycle time and discussions on cycle time optimization was discussed [1]. The manpower allocation strategy was also revamped to fit the new layout and avoid manpower excess or shortage [2]. The supply chain system was tuned to reduce the inventory level on the floor, thus lowering down the inventory cost [3]. Each of the five projects improved one aspect of the operation of the production line and collaboratively increased the efficiency of the system. In this thesis, visual management system and new layout design are discussed in detail and the other three aspects are covered in theses of the other three teammates.

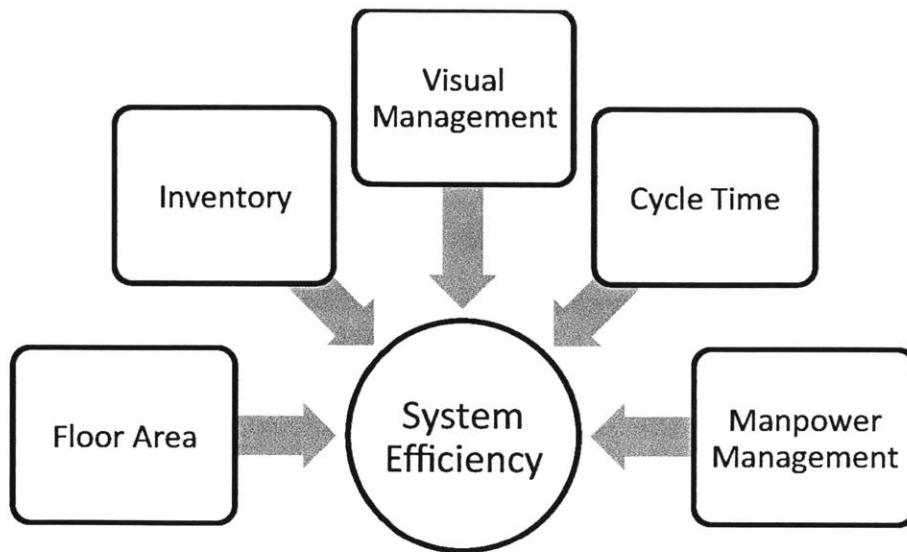


Figure 1: The Five Projects to Improve System Efficiency

## 1.2 Thesis Organization

Chapter 2 identifies the problem in this project, defines the scope and the goals of this project, providing a basis for the entire project. Chapter 3 gives a high level overview of the approaches used throughout this project. Chapter 4 provides existing research and knowledge from literature, showing some common tools and theories used in projects with similar nature. Chapter 5 depicts the current production system, including the product itself, physical layout and processes. Based on the understanding of the current production system, preliminary analysis on the current production system is conducted in Chapter 6. Chapter 7 presents the development process of the new floor layout design, including general guidelines used in designing, creating different proposals and improving proposals based on feedback and project scope. Chapter 8 presents the development process of the visual management system. Key performance indicators are discussed and different visual management tools are developed to facilitate system efficiency improvement. Chapter 9 discusses the key conclusions and recommendations from this project.

## **2. Problem Statement**

This chapter identifies the challenges within the manufacturing system and the objectives to achieve at the end of the project.

### **2.1 Problem Identification**

The MIT team was brought into the medical device company to reduce the floor layout area of an occlusion product line. The product is a legacy product that has been in market for more than ten years and has seen a low demand in the market. Despite the decreasing demand, the production line takes up a considerable space in the clean room area. As future business expansion is constrained by the clean room space, the company wants to revise the current floor layout and introduce a new production line to the saved space.

Due to the life stage of the product, the product line has not received much attention from the engineering team and management team for years. No revision of production line has been done. Despite the wide use of visual management tools on the other production lines and its proven benefit to the company, there are still no visual management tools adopted in this line. It is aligned with the company's overall strategy of being a lean manufacturing company to deploy visual management tools to this line.

After discussion with the company, the team realized that the ultimate goal of this project is in fact to improve the system efficiency of this production system while utilizing less space. There are opportunities for improvement in manpower management, inventory optimization, cycle time analysis and introduction of visual management. These aspects benefit one aspect of the business and show synergy in overall operation. By analyzing every aspect of a production system, the team would be able to provide a comprehensive analysis on the system and thus improving the system efficiency as a whole.

### **2.2 Project Scope**

The primary objective of this project was to improve the system efficiency in the occlusion system assembly line. One key objective was to reduce the footprint by one third of the original



area. The other goal of this project is implementation of effective visual management on the floor.

Before proceeding with the project, it is essential to understand the scope of the project and keep constraints in mind. This project allows the team to adjust the following:

- Tooling and fixtures.
- Process flow and working benches for the occlusion system's catheter subassembly, the accessory subassembly, the syringe subassembly, and the sheath subassembly.

On the other hand, there are certain design elements that are out of scope for this project, in particular those outside the floor layout, including:

- The coating and packaging areas outside the floor.
- This product is a FDA regulated medical device. The team must avoid new regulatory filings caused by changes to the design specifications or materials.

### **2.3 Other Concentrations**

This thesis discusses the findings on floor reduction and visual management, which floor reduction was achieved by collaborative effort and visual management was an individual concentration. The other three teammates in the team tackled other aspects in the manufacturing system:

Abdulaziz AlEisa studied the current manpower and cross training status as well as the lead time for each subassembly. Moreover, a model was provided to determine the optimal manpower requirement to run the production line for different volumes and layouts. This project covered a comprehensive analysis of the new layout effects on the manpower requirement as well as future suggestions to increase the efficiency and flexibility of the production line.

Jennifer Peterson analyzed the cycle time of the current layout. She analyzed the process map using metrics such as space, batch sizes, and line balancing to explain the resulting cycle time of the certain process. Suggestions were provided showing possible ways to improve cycle time and the productivity of the space used.

Tianying Yang analyzed the strategy of decentralizing the supermarket and provided a decentralization plan. The plan proposed a replenishment schedule that minimized parts inventory on the floor where appropriate. New color coated Kanban cards were designed with bench number indicated. A unified replenishment strategy was proposed for different subassemblies. Other detailed problems were considered during supermarket decentralization such as feasible ways to store large size containers.

# 3. Methodology

This section describes the methods the team applied to understanding the system, creating proposals and improving proposals.

The high-level methodology process followed six steps. These were defining project objective, capturing current state, analyzing current state, designing Proposals, reviewing and improving proposals. The last three steps were repeated in iterative approach. If a design required amendment, the process was back to designing layouts step with improvements made.

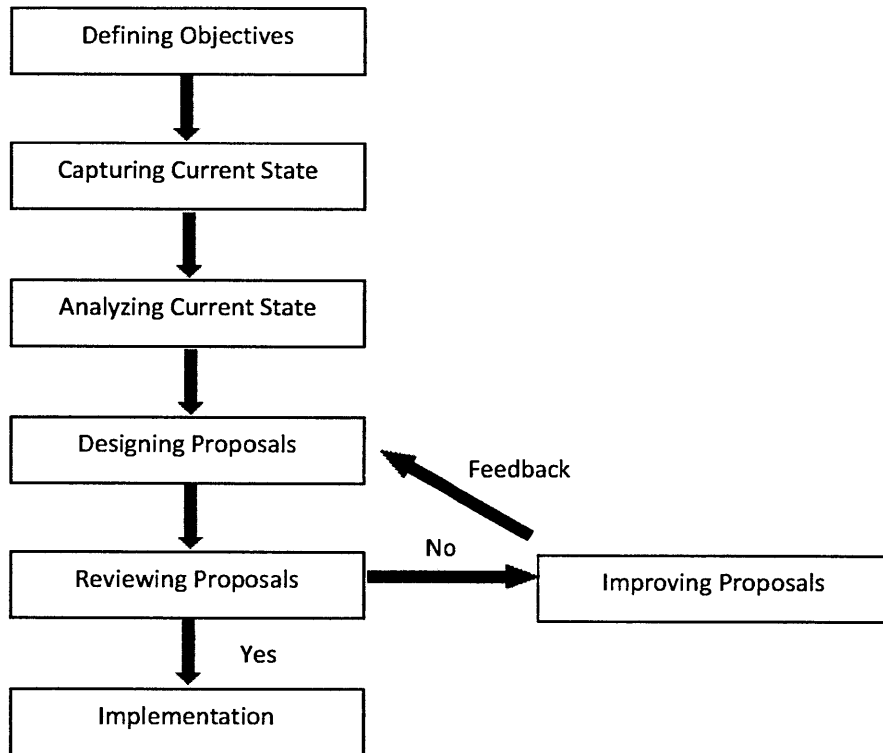


Figure 2: High Level Overview of Methodology

## 3.1 New Floor Layout Design

### 3.1.1 Defining Goals

The goals were defined in the initial meeting with management team, including site leaders and line supervisors. Objectives were defined in numbers to quantify the goals and management

engagement was confirmed to this project. The goals were reviewed in subsequent meetings to assess its feasibility. It was necessary to be consistent with and focus on the project scope.

### **3.1.2 Capturing the Current State**

To get sufficient knowledge in the product line, the current state was recorded. This included measurement and observations of both the physical layout and the operational systems used.

To capture the physical layout, the manufacturing system was measured by measuring tapes and pictures were taken for reference. The current layout was modeled using Solidworks. All equipment and fixtures were also included in the Solidworks model with dimensions. Tours were conducted by engineers and production associates to understand current process flow, inventory level, replenishment strategy, physical layout, equipment list and constraints of manufacturing operations.

### **3.1.3 Analyzing the Current State**

Based on data obtained in 3.1.2, a preliminary analysis was conducted to review the efficiency of the system using indicators like utilization rate, production rate and cycle time. These analyses revealed issues in the system which would be addressed in the new design.

### **3.1.4 Designing Proposals**

In designing proposals, brainstorming sessions generated creative ideas and hypotheses. Hypotheses were discussed with engineers and production associates to verify their relevance and importance. Several new designs were created based on relevant hypotheses and certain constraints. All aspects related to the production system are considered to maintain reasonable efficiency of the line. Cycle time should not be compromised in order to fulfill the maximum demand of the product. Parts replenishment should be as efficient as before to prevent shortages and place inventories at the most accessible locations. The new layout should also provide flexibility in manpower allocation on the line for varying demands. In addition, visual management should be in place to monitor production performance and enhance information flow on the floor.

### **3.1.5 Reviewing Proposals**

Each design was simulated as a 3-dimensional model and reviewed with management team and production team. The main evaluation criterion was determined with the company. Proposals were presented to the management team and discussed the benefit of each one. Proposals then were presented to the production team to identify operational issues or any personal concerns.

### **3.1.6 Improving Proposals**

New constraints and operational challenges were identified to refine the project scope along the way. Problems that were identified during review meetings were addressed by a new round of creative brainstorming and suggestions from the company. Revamped layouts went through another round of review session.

## **3.2 Visual management**

### **3.2.1 Defining Goals**

This is a similar process as discussed in Section 3.1.1.

### **3.2.2 Capturing the Current State**

For visual management project, more attention was paid to understand the process flow and interactions between the production line and other parties, such as management team and warehouse. The overall information and material flow map was captured. Cycle time and lead-time of the product were recorded as well.

### **3.2.3 Analyzing the Current State**

Through interviews of production manager, production supervisor and production associates. Key performance indicators concerning each party were identified and categorized to groups. Several sessions were conducted to observe production activities on the floor and record the interactions among different parties.

### **3.2.4 Designing Proposals**

Proposals were developed based on the key performance indicators. Those indicators serve two purposes on the line: one is to track the real-time performance on the floor, such as production rate and yield; the other one is to trigger proactive actions to prevent potential problems. The

idea here is to make information flow more visual so that people from different perspectives understand the status of the system by looking at key performance indicators and pay attention to the line when problems occur. An interactive communication system was integrated into the system to encourage production associates to make constant suggestions, and thus performance would be improved.

### **3.2.5 Reviewing Proposals**

The management team and production team reviewed the proposals during meetings.

Questions during the meetings or follow up discussions revealed problems within the proposal and provided suggestions that could improve the proposal.

### **3.2.6 Improving Proposals**

Similar to Section 3.1.6.

## 4. Literature Review

In order to understand the methodologies used in the manufacturing field, the team researched methodologies such as lean manufacturing, six sigma, and lean sigma. The team looked at the history and characteristics of each. For visual management, the definition of system performance and key performance indicators were discussed, followed by frameworks to design proper metrics for a system. Applications of visual management in past projects were also examined to understand its benefit and key factors to success.

### 4.1 Lean manufacturing

Lean manufacturing is a manufacturing philosophy that focuses on continuous improvement and reduction of waste. The system encourages maintaining a smooth flow throughout the manufacturing process, usually this system is applied to automobile industry. It reduces the amount of inventory in the system, thus shortening the cycle time and reducing the cost of work-in-progress parts. The concept was derived from the Toyota Production System in late 20<sup>th</sup> century. It was first discussed by John Krafcik [4]. Krafcik introduced two new terms buffered and lean production systems. Krafcik mentioned how the production systems of most western producers after World War II were buffered against almost any problem with high component and finished goods inventory levels. The core elements of lean manufacturing consist of inventory management, set-up reduction for flexible capacity, cells design, Andon, Kaizen, and Poke-Yoke [5].

Inventory management aims at reducing inventory at warehouse and work-in-progress inventory. Process flow is designed to have the same cycle time. Working parts are passed to the next stage at the same time the next process is available. Line balancing is applied in order to equalize the takt time for each process. The system is tuned to be reliable, embedded with mechanisms to self-correct, so that the process flow is smooth without disruption by defects. In order to reduce inventory levels, a pull system is created with Kanbans to indicate the status of the system. As a result, timely replenishment can be achieved and lower inventory levels are required on the floor.

Shorter set-up time reduces the downtime during changeovers, making it less costly in terms of time to manufacture another product, thus increasing line flexibility.

Cell design features sequential operations. Machines and tools are grouped according to the family of parts being produced in the line. One part is produced while moving around the cell. In doing so, one-piece flow is achieved, improving material flow and significantly reducing cumulative lead time.

Andon refers to a system that notifies all personnel, such as management, maintenance and engineers, responsible for a quality or process issue on the floor. A signaling system can be activated either by manually pressing a button by a worker or automatically by a monitoring system. It assigns workers the responsibility to stop production in the occurrence of a defect and calls for attention. As a result, problems can be resolved once they occur [6].

Kaizen is a daily process, focusing on continuous improvement of business. The current operation is reviewed on a daily basis to eliminate waste and improve process reliability. It requires constant engagement of workers as well as management in the organization. The culture of continuous improvements leads to significant overall productivity improvement.

Poke-Yoke is a mistake preventative system to avoid defects and human errors, thus improving quality yield. Workers are responsible for the machine they use and parts being produced. Together with Andon, part quality is checked at every cell, problems are made visible to whole working team immediately.

Womack in Lean Thinking stresses the importance of creating value for the customer [7]. All these tools and methods outlined above, including flexible capacity, cells design, Andon, Kaizen, and Poke-Yoke can help to create value. The objectives of the lean enterprise are to correctly specify value for the customer across the firm, to identify all the actions involved in the product, and to remove any actions which do not create value. In addition in the continuous process of Lean Manufacturing, once you fix a process, fix it again.



## **4.2 Six Sigma**

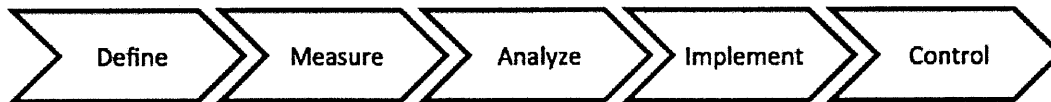
The Six Sigma approach name comes from that in a normal curve, six standard deviations or sigmas, from the mean on each side constitute 99.99966% of the sample. There would only be 3.4 defects per one million. Motorola's Bill Smith introduced the Six Sigma method in 1986 [8]. According to Motorola University, Six Sigma is a metric, methodology, and a management system. Six Sigma started as manufacturing effort that was then applied to other business processes to reduce defects. It became even more popular when General Electric Corporation adopted Six Sigma in the mid-1990s as part of leadership development. The Six Sigma approach also introduced and supported the idea that improved quality pulls down the overall cost.

The focuses of Six Sigma are to understand and manage customer requirements, align business process to achieve those requirements, utilize data analysis to minimize variation, and drive rapid and sustainable improvement to these business processes [9]. The data analysis involves statistical techniques, such as control charts and statistical process control. The second generation of Six Sigma has taken into consideration situations where Six Sigma does not apply as well, particularly human intensive processes such as marketing and human resources [10].

## **4.3 DMAIC**

DMAIC was developed as a problem-solving procedure in the Six Sigma approach that guides a project by evaluating root causes of problems and implementing best practices to improve those processes. DMAIC consists of five steps, namely define, measure, analyze, improve and control. The five steps are conducted in sequence and can be used as milestones for project management. The define phase is to identify valid improvement opportunity, clarify critical customer requirements and establish a project charter to define project goals. The measure phase is to determine what variables to measure, collect data in a planned manner. In the analysis phase, collected data is analyzed to determine process capability, throughput and cycle time. Hypotheses are made to verify root causes for variation. After hypotheses are established, the improve phase generates potential solutions based on data analysis and actions are taken to evaluate the validity of solutions. The final solution is reached in this phase and approval for implementation takes place. In the control phase, attentions are paid to

monitor and control critical outputs. Continuous improvements are made to avoid mistakes in the system [11].



**Figure 3: Roadmap of DMAIC**

#### **4.4 Lean Sigma**

Lean six sigma is an approach focused on improving product quality, reducing variations in production and reducing cost at the same time [12]. It is a combination of two process-improving techniques, Six Sigma and Lean Manufacturing as described above. The outcome of these two combined contradicts the prevailing view at that time this method was introduced that quality is at the expense of extra production cost.

A lot of studies have been done on Lean Six Sigma applications in private sectors. Maytag Corporation designed a new production line using the concepts of Lean Six sigma in 1999. The production lines space was reduced to one third of the original lines. Maytag also cut production cost by 55% [13].

#### **4.5 Concerns about Lean Six Sigma Approaches**

In 2000, the board of 3M selected James McNerney as the new CEO. McNerney was trained in the Six Sigma practices taught by Jack Welch at General Electric. McNerney implemented these six sigma practices cutting costs and improving productivity, however at the risk of new projects. 3M had been successful because of its innovation and creativity. The statistical analysis did not apply well when in the research and development process there are few facts and the nature of the problem is undefined. If unchecked the culture of Six Sigma can stifle creativity because the motivations of each culture are very different. Six Sigma stresses analysis, while innovation stresses creativity and new projects [14].

The lasting impact of lean manufacturing and six sigma projects can be questioned as well. Almost 60% of companies to implement one of these programs fail to yield the desired results.

The program's success can be declared too soon and the managerial emphasis is lost leading to increased discouragement. The gains made using these methods can then slip away. Ways to continue the successful use of these projects can include keeping the involvement of improvement experts, lining up incentives with improvement initiatives, small teams and small time frames for the projects, and finally maintaining direct involvement from the executives [15].

#### 4.6 Lean Sigma at the company

The company began focusing on their use of lean sigma techniques in 2006. From the company's training manual it says "In Lean Sigma there is a saying: blame the process, not the people." The Lean Sigma method combines the waste removal, process efficiency thinking of Lean, with the variation reduction and quality improvement techniques of Six Sigma.

The method that the company uses usually follows the pattern of first balancing the flow of the processes using lean manufacturing methods and then using Six Sigma practices to reduce the variation of the process [16].

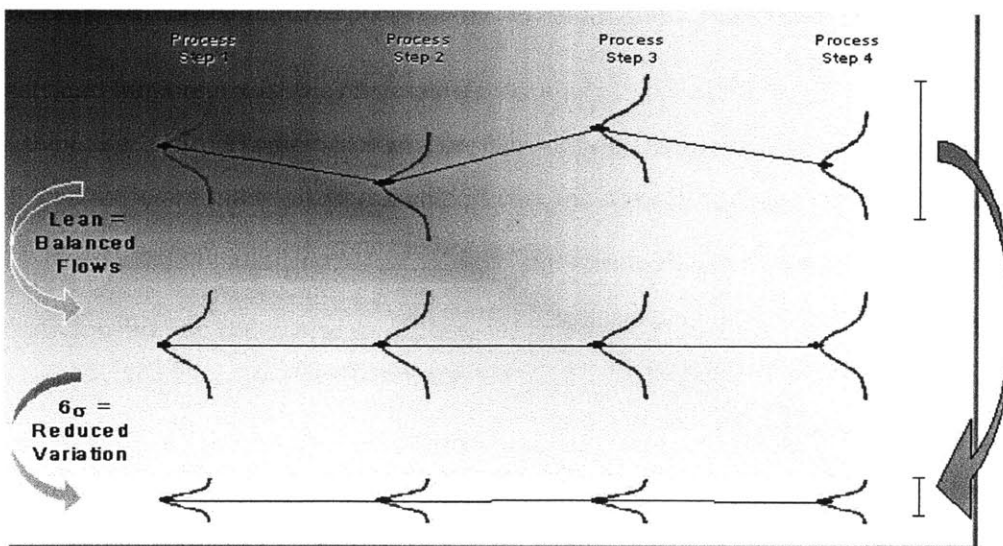


Figure 4: From Normal to Lean to Lean Sigma

An example of a successful Lean Sigma project at the company is another similar product. In 2007 the company implemented these practices on the product. In the period between 2007 and 2010 the average yield increased 6%. The productivity increased which reduced labor costs per unit significantly. There was a decrease in lead time as well. The sales increased as well as a decrease in customer complaints. The company uses many Lean and Six Sigma tools, including the DMAIC methodology. Other Lean and Six Sigma tools include 6S, VSM, MSA, Kaizen, Kanban, C&E Matrix, A3, Standard Work, and DOE.

#### **4.7 Visual Management**

As an important part of lean manufacturing, visual management is deployed as part of Andon technique to inform anyone entering the floor space with essential information about what is going on the floor, what is under control and what is not. People without deep knowledge about the operation would be able to assess the current performance of operation based on the information presented on visual management at a glance.

##### **4.7.1 Defining System Performance**

Since visual management is used to describe system performance, it is important to define system performance. Despite the complexity of system and the fact that no formal mathematical modeling is available to describe system performance, some general relationship has been identified [17].

Couzens defined the performance of a system as a function of four factors: system inputs and outputs, design parameters and resources employed:

Performance = F(Inputs, Outputs, Design Parameters, Resources) [18]

In measuring a company's ability to produce a product, Anupindi identified four process attributes: cost, flow time, flexibility and quality [19]. All of them are applicable to the company's business activity.

1. Cost: Represents the total cost that the company incurs to produce the product. The total cost includes variable cost (such as raw materials, utilities and labor), fixed cost (equipment and land), overhead costs and inventory.

2. Flow time: equivalent to cycle time. It is the total time to produce one batch of product on the floor.
3. Flexibility: With respect to the company's variety of products, process flexibility indicates the capability of the company in meeting customer's needs in a portfolio of products.
4. Quality: The quality of medical device is always a key factor in assessing the performance of a system. A number of key dimensions and operations ensure that the function of the device is delivered properly. Any failure in those factors result in a reject.

Adding these four important process attributes to the performance function, a more general performance function for a company is modified to be

Performance = F(Inputs, Outputs, Design Parameters, Resources, quality of output, flexibility, cycle time, cost) [19]

All factors discussed above have an effect on the performance delivered by the system. Each of the factors can be further decomposed into more quantitative variables. Therefore, they can be used to describe the performance of a system. The number of variables of a system is related to the complexity of the system.

#### **4.7.2 Key Performance Indicators**

Key performance indicators are usually a set of high-level metrics used to measure an organization's performance. Each key performance indicator is a function of a set of low-level metrics and the number of key performance indicators is no more than a dozen [20].

#### **4.7.3 Designing Metrics**

Identifying key performance indicators is of great importance in visual management. Metrics have to be designed in a way that it is operational on daily basis without creating additional workload to the production team. There are many frameworks available for designing effective metrics [20].

SMART framework is a good guideline for evaluating effective metrics.

S=Specific: each metric must be specific and no confusion in the terms

M=Measurable: each metric must be able to be quantified

A=actionable: each metric must be actionable for improvement or changes. Also indication of action needed has to be available.

R=Relevant: each metric must be relevant to the business.

T=Timely: the time horizon of data capture must match that of the ability to respond.

On a factory floor, metrics have to be relevant and timely to reflect day-to-day operations. They have to be designed “smart” enough such that both production associates and the management team can understand and manage those without much difficulty.

The University of California provides the following eleven questions to measure the quality of a metric [21].

1. "Is the metric objectively measurable?"
2. Does the metric include a clear statement of the end results expected?
3. Does the metric support customer requirements, including compliance issues where appropriate?
4. Does the metric focus on effectiveness and/or efficiency of the system being measured?
5. Does the metric allow for meaningful trend or statistical analysis?
6. Have appropriate industry or other external standards been applied?
7. Does the metric include milestones and/or indicators to express qualitative criteria?
8. Are the metrics challenging but at the same time attainable?
9. Are assumptions and definitions specified for what constitutes satisfactory performance?
10. Have those who are responsible for the performance being measured been fully involved

in the development of this metric?

11. Has the metric been mutually agreed upon by you and your customers?"

These questions can be asked when designing metrics and also in evaluating existing metrics. They linked the metrics with stakeholders and interactions between stakeholders.

The University of California also classified performance metrics as summarized in Table 1.

Table 1: University of California Performance Measures [21]

Measure of...	Measures...	Expressed as ratio of...
Efficiency	Ability of an organization to perform a task	Actual input/ planned input
Effectiveness	Ability of an organization to plan for output from its processes	Actual output/ planned output
Quality	Whether a unit of work was done correctly. Criteria to define "correctness" are established by the customer(s).	Number of units produced correctly/total number of units produced.
Timeliness	Whether a unit of work was done on time. Criteria to define "on-time" are established by the customer(s).	Number of units produced on time/total number of units produced.
Productivity	The amount of a resource used to produce a unit of work	Outputs/inputs

The five classifications covered the major aspects of system performance. This can be used as a guideline in identifying key performance indicators.

#### 4.7.4 Applications of Visual Management

Daniel Wolbert's research showed the impact of visual metrics on operational improvement at a manufacturing facility in several aspects [22]. These are

1. Increased visibility into the inspection process. Inspection backlogs were informed in a smoother and timelier manner. This provided more current status of the system, in terms of first pass yield. In turn, it enabled the process to be kept in control more regularly.

2. Downstream processes had more visibility into the arrival of inspected parts.
3. More rapid feedback and smooth communication allowed for quicker continuous improvement cycles.

Daniel also mentioned that in order for a metric to produce value-add behavior, the metric has to be in line with a company's strategic goals. The desired performances have to be captured and designed with careful considerations. Strategy has to be translated to the proper level throughout the organization such that metrics can be tailored to drive the right behavior. Also authorities and responsibilities should be given to those that can influence the performance metrics and encourage them to move the performance indicators to the virtuous direction [22].



# 5. Current Production System

This chapter describes the product produced on the production line, how each subassembly is assembled on dedicated lines and summarizes the current layout on the floor.

## 5.1 The Product

The Company offers a variety of medical devices. This particular production line produces embolic protection catheters to prevent emboli from moving down the bloodstream. Emboli are the debris created by catheter products in the arterial system. The product is an occlusion type protection system. The product blocks the artery below the target site and prevents emboli from passing by. There are three main components to the product, the catheter, the syringe, and the accessory. The product is offered in two types. A separate catheter is used to aspirate the debris from the artery. The product is used for both heart and brain applications, namely Coronary Artery Embolic Protection and Carotid Artery Embolic Protection. The product has demonstrated a reduction in cumulative major adverse cardiac events (MACE) following saphenous vein graft interventions. When compared to unprotected procedures, there was a reduction in myocardial infarction, MACE, and mortality.

## 5.2 Current Manufacturing Operations

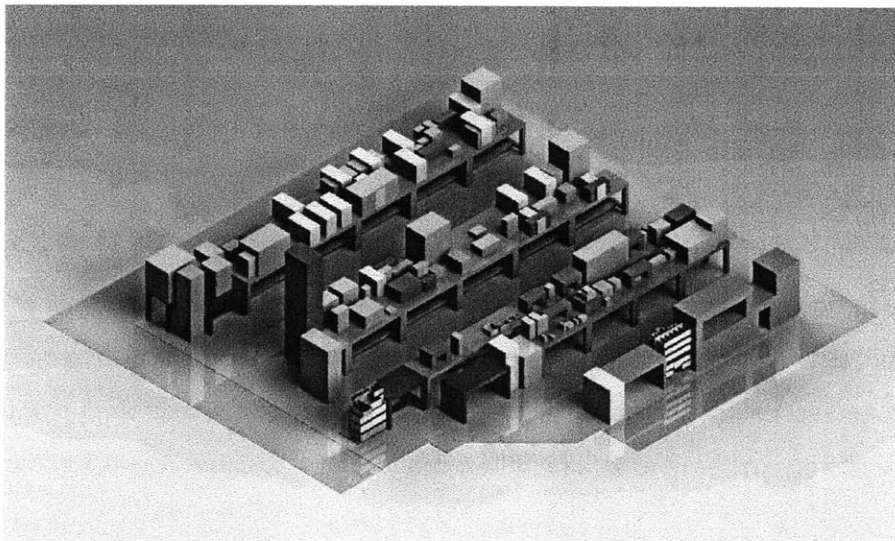
Manufacturing operations on the floor involve assembling and testing products. All parts and some subassemblies are bought from suppliers and are delivered to the warehouse. The catheter consists of many different materials and even subassemblies. It is the most complex assembly in this product. The syringe and the accessory are mainly made of injection molded parts, and require different manufacturing operations from the catheter. The different components, the catheter and its subassemblies, the syringe, and the accessory are assembled on dedicated manufacturing lines.

All of the manufacturing processes are manual and require a high degree of operator interface and skill. The line measures and tests the product's performance as well as manufacturing the product. Most of the processes require table top machinery and fixtures. There is only one shift operating on this line. The production associates on this line range from 4 to about 9 depending

on volume demanded. The production rate is relatively low compared to other products in the company as it serves only few dedicated countries.

The current floor space used by this manufacturing line is 1528 square feet. The occlusion system manufacturing area is nestled along another product line and the wall in the manufacturing area. The 1528 square feet measured area includes the necessary aisle space for the production benches. The total production line length is approximately 170 feet, where line length only includes the length of the production benches.

As shown in Figure 5, the production area's current layout consists of seven rows of production benches, computer desks, cabinets, and shelves. It is observed that equipment takes most of the spaces on bench top. Most of the equipment is placed on the production benches, however some equipment is placed to the side, above or below. Each production bench is dedicated to particular assembly procedures.

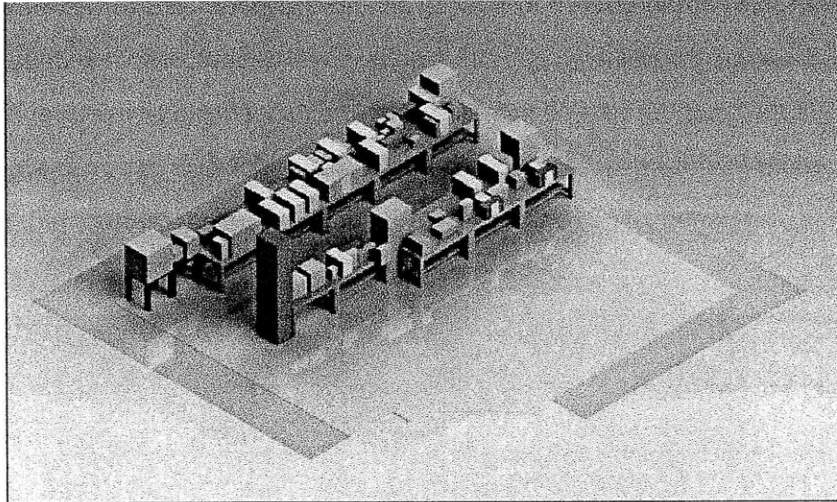


**Figure 5: Overview of the Current Floor Layout**

### **5.2.1 Catheter Subassembly**

The catheter line consists of approximately 22 production benches, distributed along four rows of benches. The total line length used for the catheter is 120 feet. The equipment used for the catheter assembly include many microscopes, laser micrometers, ultraviolet light source

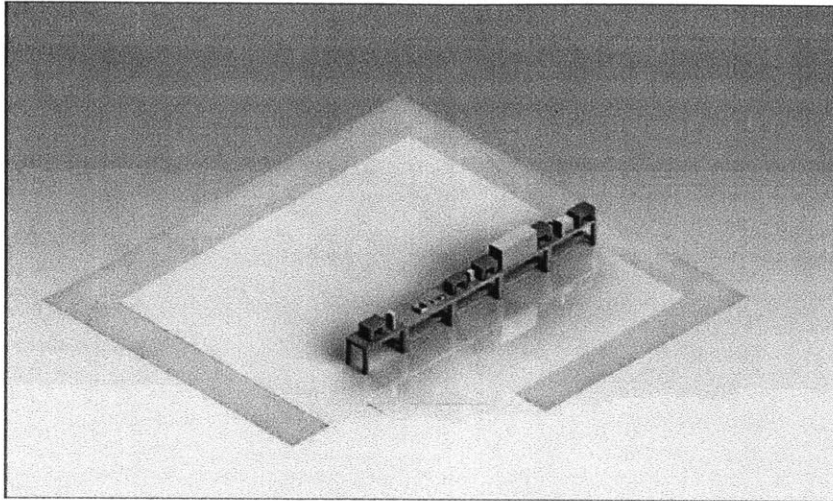
machines, ultrasonic cleaning machines, an EDM machine, hotboxes, and an oven. There are a lot of dedicated operations under microscopes and using fixtures. The current operations require space for the long catheter to lay flat on the production benches. Depending on the volume required that day, there are four to six production associates working on this line.



**Figure 6: Catheter Subassembly**

### **5.2.2 The Accessory Subassembly**

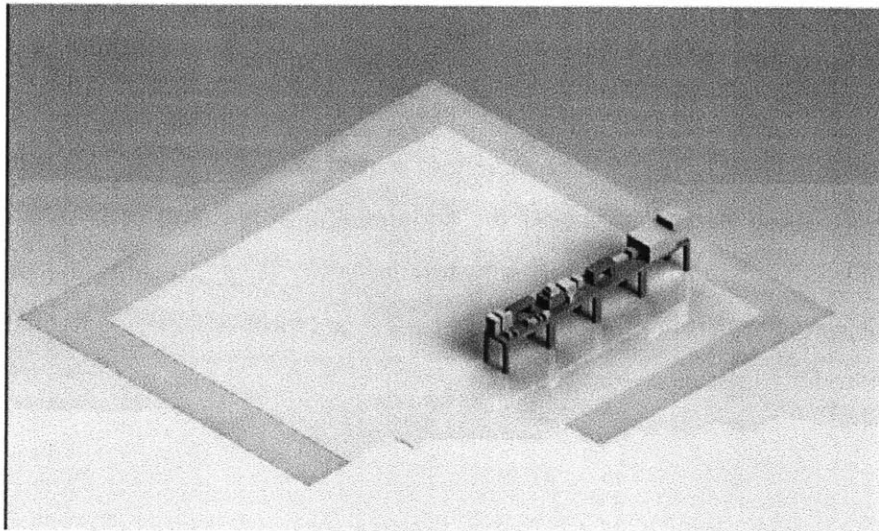
The accessory line has six production benches all in one row, with a line length of 29 feet. The equipment used for the the accessory assembly include an ultraviolet curing machine, presses, fume hoods, and screwdrivers. The operations here are mostly mechanical assembly and adhering parts together. Ventilation system extracts hazardous chemicals to protect production associates. The accessory line has usually one to two production associates working on this line.



**Figure 7: The Accessory Subassembly**

### **5.2.3 The Syringe Subassembly**

The syringe line has three production benches all in one row, with a line length of 20 feet. Equipment used for this line include fume hoods, presses, and screwdrivers. The syringe subassembly line has usually one to two production associates working on this line.



**Figure 8: The Syringe Subassembly**

#### 5.2.4 Sheath Subassembly

The Sheath has two production benches for a total line length of 12 feet. Much of the equipment is specialized for just this assembly, including a microscope and hotboxes. There is usually one production associate working on this subassembly.

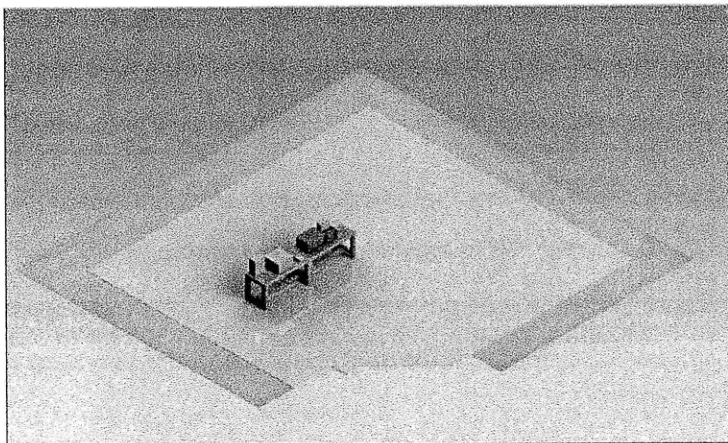
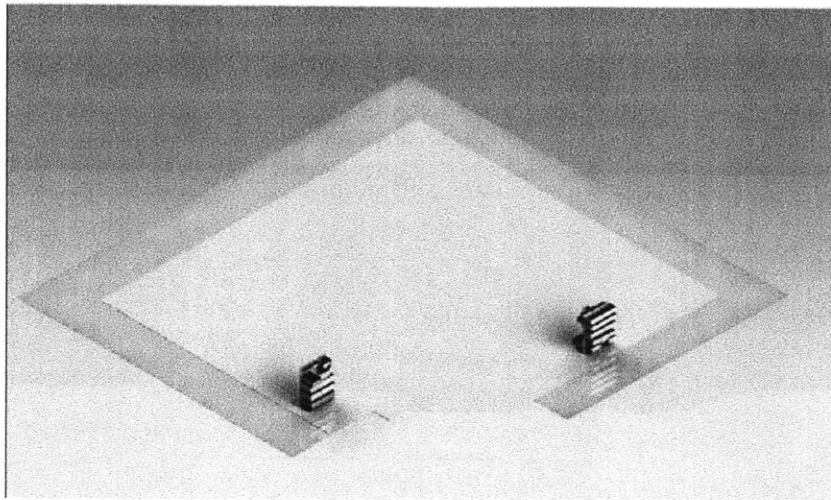


Figure 9: The Sheath Subassembly

#### 5.2.5 Supermarket

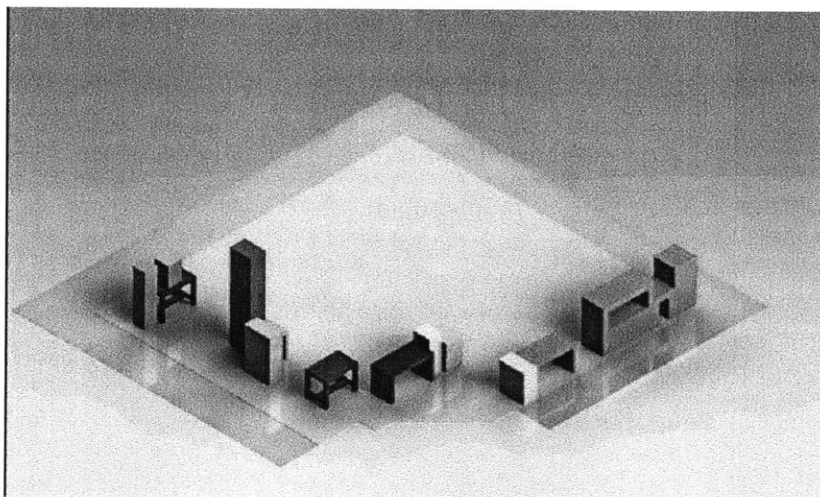
Parts and subassemblies that are needed on the floor are supplied by warehouse and stored on shelves of two supermarkets. Separate bins are used to store each parts and parts are grouped by the subassemblies where they are used for. Production associates get parts from the supermarket to make subassemblies. A Kanban system is used to control the inventory level of each part. The warehouse personnel checks the supermarket at the end of a shift in the afternoon. He collects Kanban cards of bins with low inventory level, prepares the parts at warehouse and delivers the parts to the supermarket the next morning. Supermarket acts as a central storage place for all parts.



**Figure 10: The Supermarket Areas**

### **5.2.6 Other areas**

Other areas include computer desks, cabinets, chemical storage areas, along with other miscellaneous items. Computer desks are used by safety trainers and technicians who facilitate production on the floor. Cabinets store documents and stationaries for engineers and technicians. The total length of these other areas is 30 feet and is split up among all of the rows.



**Figure 11: Other Areas**

### 5.3 Summary of Current Production System

The floor space is separated by 6 straight rows of benches that belong to specific subassemblies. The lines include all equipment and operations that are associated with each subassembly. The 7<sup>th</sup> row consists of supermarket and other miscellaneous items. A summary of each subassembly is shown below:

**Table 2: Summary of Floor Layout for each Subassembly**

	Rows Used	Benches	Total Line Length (sq feet)	Production Associates
Catheter	4	22	270	4-6
Accessory	1	6	73	1-2
Syringe	1	4	50	1-2
Sheath	1	2	30	1
Supermarkets	NA	NA	15	NA
Other Areas	NA	NA	124	NA
<b>Total</b>	7	34	562	7-10

The whole process is complex and contains different kinds of equipment. Due to the delicate operations required, many fixtures and customized equipment are on the line. Equipment is highly dedicated to specific operations. With no equipment sharing on the floor, there is much equipment performing the same service. This means that each operation is totally isolated from the adjacent ones. One can perform one operation using dedicated machines without disturbing other operations. This level of isolation makes it possible to conduct all operations at the same time, maximizing productivity. However, due to the current low demand of the product and much fewer number of operators compared to the number of operations required, the excess of equipment takes up space on the floor.



## **6. Preliminary Analysis**

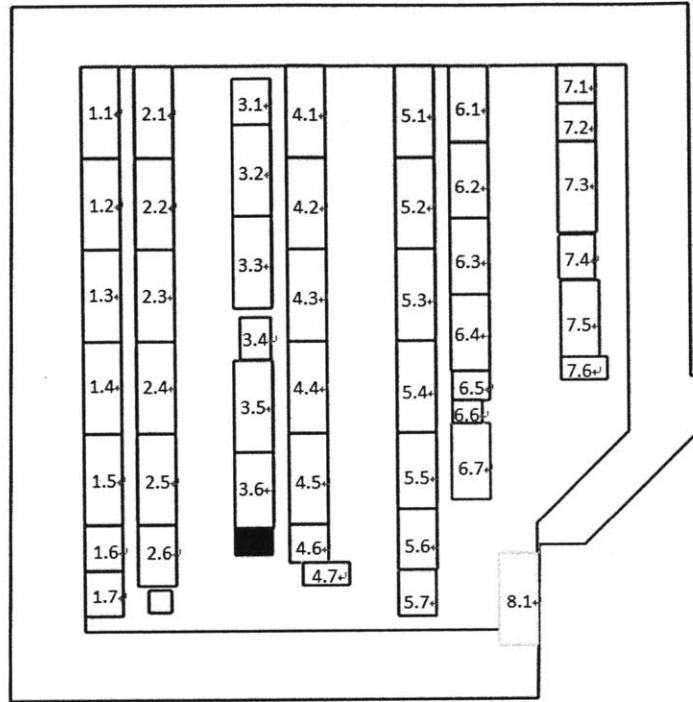
The chapter discusses some preliminary analyses on the current floor layout. Analyses include a numbering system to present the physical layout, process flow chart, overall information flow and material flow, product family matrix. Main findings and implications regarding to new layout design and visual management design are discussed.

### **6.1 Bench Numbering System**

Currently each bench on the floor is not assigned an official number but rather called by the operation performed. This works well when the layout is unchanged and people have sufficient knowledge in each operation. However it creates difficulties for people not working on the line to understand the layout in drawings and making references to benches. In addition, in designing a new layout, a concise but effective naming system is required to facilitate people with different knowledge in this project to understand the movements and changes. Therefore, it is necessary to create a numbering system for this production line.

According to the number of row on the floor and the sequence in the row, each bench was numbered with two digits. Rows were numbered from left to right. Benches were numbered from top to bottom. For example, the third bench in the fourth row was numbered 4.3. The Instron machine table besides the office was named separately as 8.1. The renumbered layout was attached below:





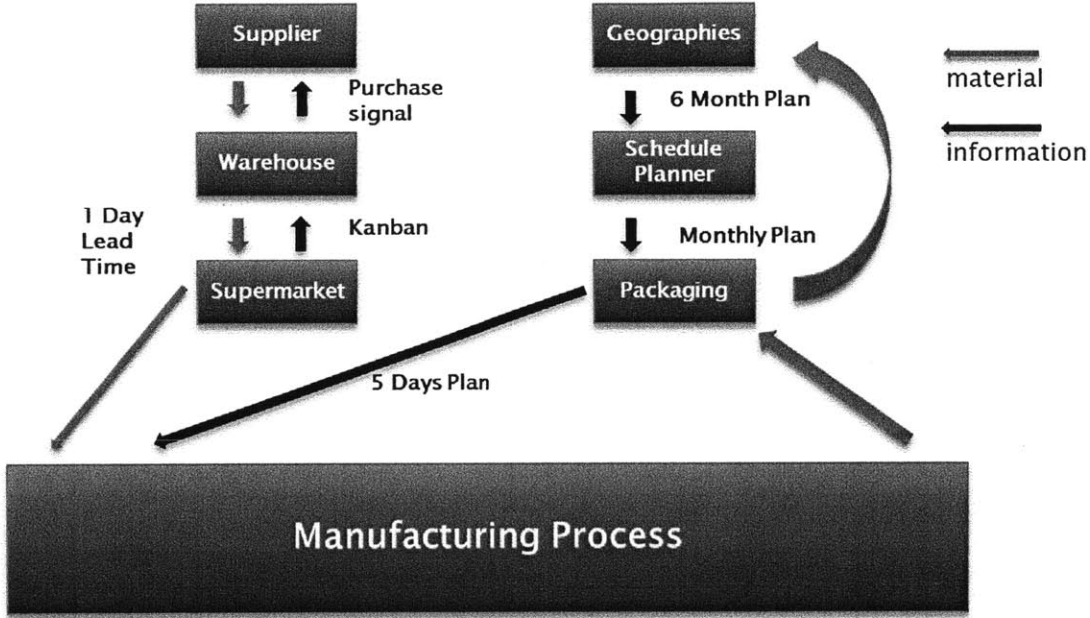
**Figure 12: Top view of the Current Occlusion System Floor with Bench Labeling**

This numbering system eliminated the communication barrier in referring to benches during discussions. Communication efficiency was improved significantly due to the common language used. It provided a systematic approach to record the detailed equipment arrangement on each bench, thus accelerating data collection process and modeling.

## **6.2 Overall Information and Material Flow**

A manufacturing system is an open system that information and material enter and exit the system from outside. Traditionally, a production line is isolated from the demand side and material supply side. Its primary function is to build as many products as possible each day regardless of the fluctuation in demand. Sufficient materials supply must be in stock otherwise production stops. This practice is known as a push system as materials are pushed through processes to become inventory waiting to be shipped to customers. Drawbacks of a push system are excess inventory and lack of flexibility in response to demand change. In lean manufacturing, the production activity interacts with the demand changes. An order triggers

the production at the same quantity. As a result, the line is only producing the amount of product in demand, no excess inventory occurs. This is an important philosophy in lean manufacturing in terms of cutting off waste due to over production and obsolescence. As this is a lean manufacturing project, understanding the current information and material flow within the manufacturing system helps to assess the company’s current lean progress and identify aspects for improvement.



**Figure 13: Schematic Diagram of Information and Material Flow**

Through interviews with the warehouse personnel, the line lead, the line manager, and demand planners the team developed the information and material flow chart that summarizes the interactions between supply side, demand side and the production line. The supply side consists of the suppliers for raw materials, the warehouse where all purchased materials are stored at the company and the supermarket where materials needed for daily production are stored in vicinity of the production line. The supermarket is supposed to store 2 days of supply for the production line and a Kanban system is used to trigger a replenishment signal to the warehouse personnel. When the inventory at supermarket is low, production associate flips the Kanban card to show the red backside. A warehouse personnel goes to the floor in the

afternoon before the end of the shift to collect all red Kanban cards and prepares the needed parts at warehouse according to the Kanban cards. The next morning he delivers the parts to the supermarket. The inventory at warehouse is managed by an electronic inventory system which tracks the inventory in stock and sends a purchase signal to the supplier when inventory is below a trigger point. It is clear that on the supply side, a pull system with Kanban cards is used to keep the supermarket always filled with parts and the inventory at a reasonable level. However, in reality due to the batch size offered from suppliers, the inventory level at supermarket is usually more than 2 days as parts are packaged in large quantity. This indicates an opportunity to bring down the inventory level on the floor.

On the demand side, a 6-month demand forecast is generated from the local market for the schedule planner. A Schedule planner then generates a monthly plan for the packaging department to inform the number of products required for packaging each month. Packaging department breaks down the monthly plan in different types of products from the line and pass on a weekly plan to the production line. Production line manufactures products according to the quantity and types of products in the weekly plan. Forecasts are used to plan the production activity, but usually forecasts are of big errors. The packaging department is also using a Kanban system for production planning in an attempt to alleviating forecast error. Packaging department stores 2 batches of inventory of each product. Once one batch is shipped to customers, they pass the Kanban card to the production line to trigger more production. This pull system would keep the inventory at packaging level low. However, it is noticed that the production line is therefore receiving two production instructions from packaging department, one is the weekly production plan and the other is the Kanban card. This practice would create a lot of confusion in production planning. Therefore, the production triggering system should be standardized to one strategy to avoid confusion.

### **6.3 Product family matrix**

As discussed in Chapter 5, the production of the product is completely manual. The majority of the space on the benches is occupied by numerous equipment. There are more than 40 operations performed on the floor. In the current layout, every individual operation has a

dedicated machine to perform it. There are over 22 different types of machines to perform dedicated operations. This is not counting the completely unique machines manufactured just for this line. A product family matrix was constructed to understand the number of machines used for similar or identical operations on the floor. The common equipment is of particular interest as some excess equipment could be identified and released from the line. This also provides insights in consolidations of some operations in the new design to maintain the same efficiency while using less space. The product family matrix below summarizes the number of common equipment on the floor. As shown in table 3, there are a lot of microscopes, fume hoods, air blowers and some other equipment on the line. Some machines perform identical operations, such as microscopes, ultra sonic cleaners and laser micrometers, while other equipment, like press machines and screwdrivers serve the same purpose but have different sizes. It is noted that the most common equipment on the line is microscope, 20 in total. By consolidating common equipment, we could reduce the number of benches required and thus the footprint.

Another interesting finding is that the syringe and the accessory assembly lines use the same set of equipment. Press machines, UV light source, fume hoods, adhering machines and screwdrivers are used to assemble the products. Therefore, both products can be assembled on one production line with the same equipment.

**Table 3: Summary of Equipment on Each Subassembly**

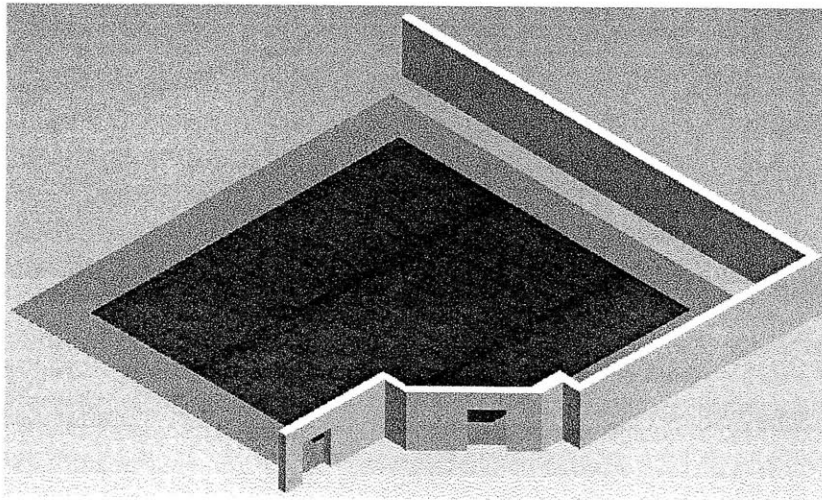
	Microscope	Laser Micrometer	Hotbox	UV Light Source	Press	Fume Hood	Adhering	Screwdriver
<b>Syringe</b>	-	-	-	1	3	2	2	1
<b>Accessory</b>	-	-	-	1	2	5	2	3
<b>Sheath</b>	-	-	1	1	-	1	1	-
<b>Catheter</b>	20	5	3	2	-	3	-	-
<b>Total</b>	20	5	4	5	5	11	5	4

## 6.4 Modeling:

Computer aided design software SolidWorks is used to develop the three dimensional models for the current floor layout to facilitate concept generation and proposal validation. The model is of real scale and important dimensions including critical aisle distance, back to back distance and safety width to the emergency exit on the right bottom of the layout.

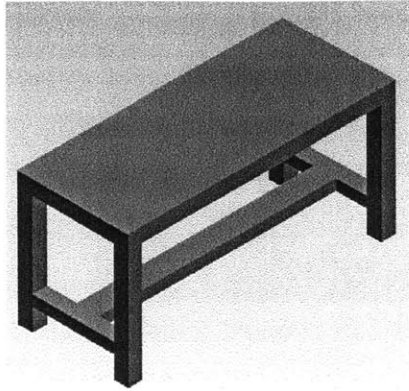
The SolidWorks include four categories of parts: production floor area with boundary walls, workbenches, apparatus and nonproduction parts. The company owns one blue print of the floor layout which is shown in the first figure in the Bench numbering system section. The file is a two dimensional CAD drawing which is modified and included in the final package.

**Production floor area with boundary walls:** the pink highlighted area represents outer aisle of the production area. Darker floor represents where benches are located.



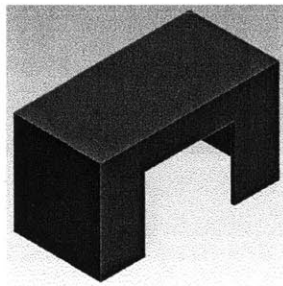
**Figure 14: Floor area and boundary Model**

**Workbenches:** the workbenches used are Phoenix Workbenches. Original models are not available from the company so benches are constructed from measurement. Five different sizes of workbenches are used in this production area: 2.5, 3, 4, 5 and 6 foot benches. A 6 foot long bench model is shown below as an example.



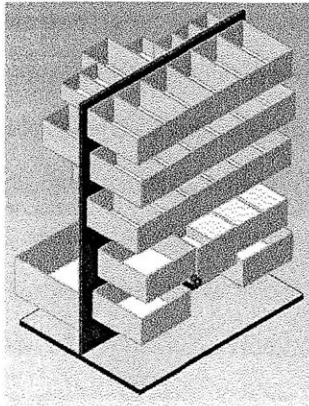
**Figure 15: Generic table model**

**Apparatus:** To simplify the modeling process, most apparatus are modeled as a block with length, width and height. Apparatus include force test equipment, leakage test equipment, microscope, laser micrometer, ultrasonic cleaner, etc. all the apparatus are located on the corresponding workbench as they appear on the floor. A fume hood model is shown below as an example:



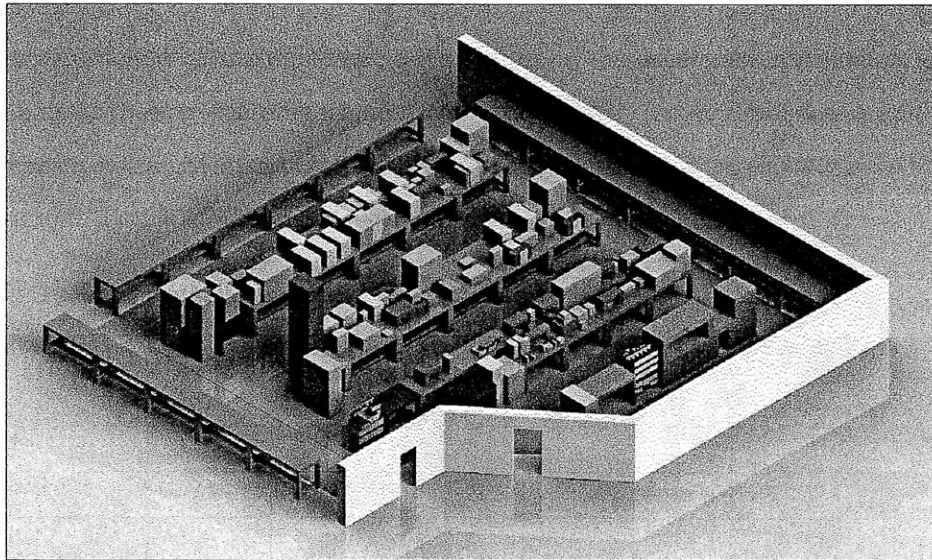
**Figure 16: Fume hood model**

**Nonproduction parts:** computer desks, file cabinets and supermarkets belong to nonproduction parts. A model of one supermarket is shown below as an example:



**Figure 17: Supermarket Model**

The whole picture of the original layout of the production floor model is shown in figure 18. The empty cyan benches are other productions lines indicating the boundary of the production area. The distances between lines are carefully measured to reflect the real operation space for production associates.



**Figure 18: Original layout model**

# 7. Development of New Floor Layout

This section discussed the development process of new floor layouts. Major opportunities for floor reduction were identified based on results in Chapter 6. Proposals with different approaches were developed during brainstorming sessions and evaluated using key metrics identified in this project. A summary of proposals was also discussed in this chapter.

## 7.1 Major opportunities for floor reduction

In order to design new layouts, several aspects were considered. These are alternative equipment arrangements, identification and removal of non-production areas from production floor, centralized supermarket compared to point of use inventory, consolidation of equipment and new bench configuration. A thorough discussion among all aspects provides various methods of reducing floor area. Linking some of the principles generates different design proposals.

### 7.1.1 Removing non-production areas/objects

“Clean room” is the term used at the company to call the area that all production activities are conducted. The space is limited in the two buildings. Therefore, it is important to increase the utilization of production area.

#### Identification of non-production items

Production items are those that are directly associated with production and assembly, including working benches that production associates performed each operation, spaces that production equipment are placed. Those spaces are used to add value to the product itself. Non-production items are items that are not directly involved in value adding but are still located on the floor. One observation on the floor is that there are a number of objects that are not directly related to production activity. Those include cabinets, fridges for chemical storage, computer desk and so on. Cabinets are very common on the floor. Some cabinets store files for maintenance technicians, production records while others store consumables and used as temporary storage space for work-in-progress parts. The ambiguity of cabinet use takes up considerable space on the floor and the majority of things stored are not facilitating production.



Fridges are placed on the production line to store chemicals such as glues when those things require storage at low temperature. Glues are small items compared to the size of fridge and the consumption rate is low. Excessive number of fridges is noticed on the floor. Computer desks are placed on the floor for various purposes. Safety trainers are stationed on the floor using computers to track safety documents. Computers for technicians are placed on the floor as office space. Other computers are used for production associates to log production records. Although each computer serves a purpose on the floor, it is noticed that none of the computers are being used fully. In addition, it is verified by the management that it is not a requirement to keep those personnel on the floor. We identified cabinet, fridge and computer workstation as non-production items.

Table 4 summarizes the number of non-production items and production related items on the floor. The number of production items including working benches and supermarket is 36 and the number of non-production items is 11. That is, non-production items consist of 25% of total objects on the floor. Therefore, sorting out and removing non-production items from the floor will increase the utilization of production space.

**Table 4: Summary of Number of Items in Each Category**

Type	Working Bench	Computer Desk	Cabinet	Chemical Storage (including Fridge)	Supermarket	Total
# of items	33	4	4	3	3	47

### **Removal plan**

In order to remove non-production items from the production line, while not disrupting daily production activity, combining storage space, relocating non-production items to less valuable space and decentralizing redundant storage are considered.

There is one fridge on product line which is merely used to store a small number of glues. After consulting the technician on the floor, we identified an opportunity to store those glues in another fridge on the floor which works under the same setting. By doing so, the fridge can be

moved for other usage and space is saved. Another benefit goes to the maintenance side, as less equipment needs to be maintained therefore technicians could be freed up for other work.

Computer workstations can be relocated out of “clean room” as those people do not have to work on the floor. The production space should be only used by production associates to make products. Facilitating parties are to be stationed in office area or less valuable place.

Cabinets that are storing files or act as temporary inventory storage should be removed. Files that are not required to be on the floor should be stored in archive place. Those required ones should be stored in smaller cabinets and place underneath working benches in order to save space. Big cabinets should be eliminated so that they are not used as temporary inventory storage.

### **7.1.2 Decentralizing inventory to point of use**

#### **Centralized supermarket**

Currently two centralized supermarkets are on the floor for the all subassemblies. Bins are placed on a shelf with Kanban cards with part number and name. Production associates obtain parts from supermarket every morning. Warehouse associate collects Kanban cards of parts with low inventory level at the end of the day and delivers replenishment the next morning. The centralized supermarket makes it easy for inventory management. Because all inventory parts are located in one place, warehouse associate do not have to deliver parts to each working bench. On the other hand, centralized supermarket takes up a lot of space: part of row 5 and half of row 7 are used as supermarket. In addition, since parts are not at the place where they are used, production associates have to go to the supermarket to obtain one day's inventory and store them on the floor. Additional inventory are created on the floor.



**Figure 19: Centralized Supermarket on the Floor**

### **Point of use inventory**

As opposed to centralized inventory, point of use inventory strategy locates each inventory to the place it is used. For example, a jaw spring is part of the accessory. Therefore, it should be stored on the working bench assembling the accessory. There are two ways of placing inventory bins: on the shelf, attach to bin rail. Each working bench has a shelf for placing documents and bins. It is above equipment on the bench; hence, bins can be stored on the shelf without disrupting operations on the bench. However, the elevation of shelf could require a certain height to reach parts on top of it. Bin rail are long plastic strips that are fixed at the back of working benches. Bins are then screwed on bin rails. Bins are therefore more accessible compared to on the shelf in terms of height but they may interrupt operations because they are close to bench surface. A decentralized inventory system meets our project object, as it takes no space on the floor to store inventory.

### 7.1.3 Consolidating equipment and shortening benches

The current layout of the product line is filled with a lot of equipment due to the large number of operations required. One way of reducing floor space is to consolidate equipment and thus reducing number of working benches. For processes that require the same type of operations, one equipment can fulfill all operations instead of having dedicated ones for each process.

**Table 5: Family Product Matrix**

	Microscope	Laser Micrometer	Hotbox	UV Light Source	Press	Fume Hood	Adhering	Screwdriver
<b>Syringe</b>	-	-	-	1	3	2	2	1
<b>Accessory</b>	-	-	-	1	2	5	2	3
<b>Sheath</b>	-	-	1	1	-	1	1	-
<b>Catheter</b>	20	5	3	2	-	3	-	-
<b>Total</b>	20	5	4	5	5	11	5	4

As shown in table 5, various types of equipment are used on the line, from optical microscope to mechanical screwdrivers. Microscope is the most used equipment: 20 microscopes are placed on the catheter line. And there are 11 fume hoods on the floor. The number of production associates on the production line is between 6 to 8. Most of the microscopes are idle at each time. This suggests that there are some excessive equipment on the floor which can be consolidated. However, before consolidating equipment, equipment has to be reviewed with great care to ensure it performs identical operation compared to the one being consolidated. Technical review and specification review are conducted by consulting quality engineer and technician.

The set of equipment required by the syringe and the accessory are observed to be similar. Both line require UV Light, fume hood, press machine, adhering and screwdriver. All operations on the syringe and the accessory lines are manual assembly and adhering parts. This similarity suggests that one set of those equipment can be utilized to perform both the syringe and the accessory operations, although only one can be performed at one time at the expense of cycle

time. However, this will eliminate one production completely and save considerable space for this project. One design based on this finding will be discussed in the next chapter.

#### **7.1.4 Change bench configuration**

As discussed in problem statement, the current layout consists of 7 lines of benches. Material flows along lines sequentially. This layout has a simple process flow but the aisle space between each line is significant.

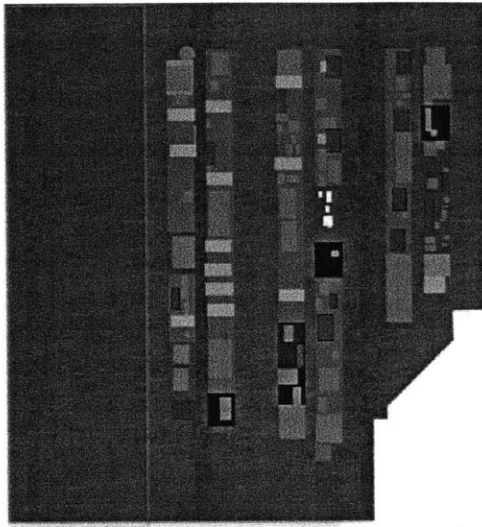
Another principle is to explore alternative line configurations besides the current layout in order to have a better process flow and increase utilization of space. In common manufacturing practice, other layouts include job shop, U-cell and transfer lines. Each layout has its unique characteristic in manufacturing activities and also in terms of space utilization. We conducted brainstorming sessions to look for alternative configuration and discussed the trade-offs specifically in our project. Detailed discussion is in next section.

### **7.2 Brainstorming different layouts**

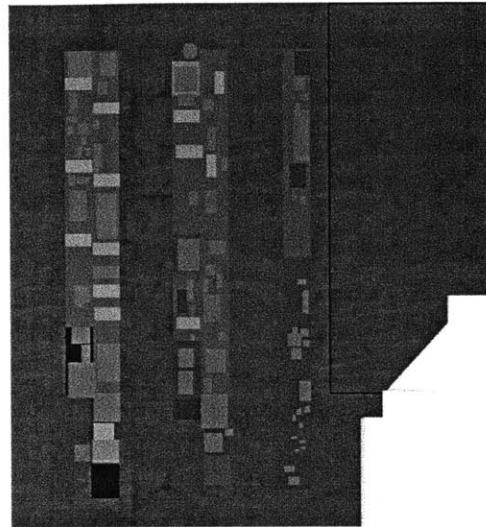
Based on the aspects for floor area reduction, several brainstorming sessions were conducted to come up with different proposals for the production floor layout utilizing the principles and. Those sessions were conducted internally (within MIT team members) and externally (including the management team, quality group, technicians, and production associate from the company). Moreover, the sessions were conducted in the form of informal meetings, floor walkthroughs, or individual discussion.

#### **7.2.1 Proposals**

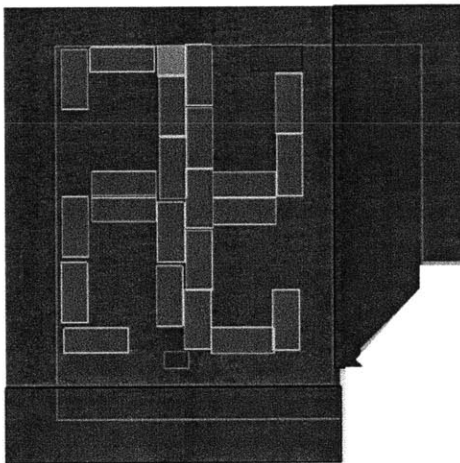
Following the guiding principles highlighted in the previous section, we developed four different proposals, they were all modeled using Solidworks and the colored background represents the original floor area and green area is the area saved in each design:



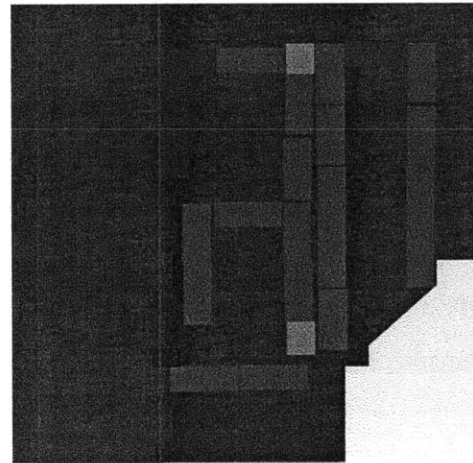
Design A



Design B



Design C



Design D

**Figure 20: Design Proposals, from left to right, top to bottom,**

**Design A, Design B, Design C and Design D**

In design A, the supermarket was decentralized to the point of use on the bench shelf. The new layout keeps the original configuration while some equipment and benches are consolidated to shorten the length of rows. The new layout design shifts to the right where the supermarket was and the saved area has an L shape with good accessibility.

Design B consolidates the equipment on the accessory and the syringe lines and thus forms one row for both subassemblies. This has been discussed in previous chapter that both lines require the same set of equipment. The saved area is on the right hand side with an irregular shape.

Design C and D are more radical and revolutionary. The idea was to create a cell operating system that production associates walk around in one cell to complete various operations. Benches were arranged not only vertically on the floor but also horizontally, increasing the area utilization. Common equipment would be more accessible for different operations as the production space were interconnected.

### **7.3 New Layout Evaluation Metrics**

Although the main goal of the project is to reduce the footprint of the production line by one third of the original area, there are other factors that are significantly considered before selecting the most appropriate layout. After discussion with the company, these metrics are identified to evaluate the cost and benefit of each new layout design. Those factors are:

#### **Saved area**

The new layout should save as much area as possible. This is the most important criterion from the company as they need more space to introduce new production line onto the floor.

#### **Area utilization**

The new free area should be accessible for the company in a way that it can be utilized for new lines. In fact, there are no specific metrics to measure this factor, however, the area should have appropriate dimensions to fit new assembly line(s) or used for other purposes.

#### **Cost of rearrangement**

The floor rearrangement should be done with minimum investment cost and with minimum interruption to the production process in the floor for different products.

#### **Ease of rearrangement**

The rearrangement process should be done with minimum manpower and paper work requirements.

#### **Tools Maintenance Time**

The new layout should be designed to minimize the required time for maintenance of the equipment and tools.

#### **Production Capacity**

Despite the current low production demand, maximizing the production capacity is desired for the new layout to account for unexpected demand increase in the future.

#### **Safety**

The area reduction should not be on the expense of the safety on the production floor. Maintaining a minimum width of 4 ft for the aisles between the working benches and 3ft for the aisles toward the emergency exit are vital requirement for any design proposal.

### **7.4 Evaluation of new layout designs**

A summary of the evaluation metrics for four designs is in table 6. All designs provide a reasonable shape for the area saved, while design A frees up the largest area among the four designs, followed by design B. The cell designs don't provide as much saved area compared to the consolidated designs. The investments of rearrangement for all four designs are the same. Design A and Design B maintain the same configuration of benches as the original layout. Design B requires the minimum rearrangement of the last two rows and Design A requires to move all benches towards right. Design C and Design D requires significant movement to the new arrangement therefore result in more logistics support and more time. Due to the new bench configuration in Design C and Design D, more potential technical risk are likely to occur compared to Design A and Design B. The technical concerns are mainly for the catheter subassembly because it requires a relatively long horizontal space that will be reduced significantly in this design. Moreover, the production rate for all subassemblies will be an area of concern that needs to be verified. In all four designs, the safety distance is kept as per request.



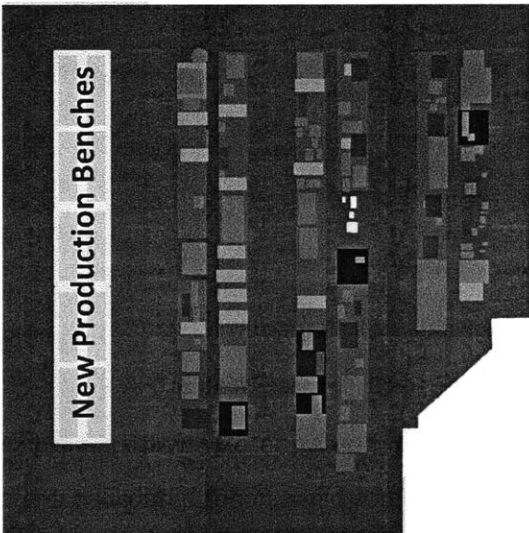
**Table 6: Summary of Designs based on Evaluation Metrics**

Design	Saved Area	Safety	Ease of Movement	Potential technical Risk	Configuration
A	476 ft <sup>2</sup>	Unchanged	Easy	Low	6 rows
B	400 ft <sup>2</sup>	Unchanged	Easy	Low	5 rows
C	300 ft <sup>2</sup>	Unclear	Difficult	High	6 rows
D	350 ft <sup>2</sup>	Unclear	Difficult	High	6 rows

**7.5 Layout Selection**

All proposals were presented, discussed, and evaluated with the management, technical staff, and operators in different meetings. Design A was selected due to the following:

- It provides the maximum saved area.
- It provides the best utilization of the saved area, where a total of 10 six-foot production benches can be introduced in the saved area as shown in Figure 5-4.
- It has the minimum cost required to purchase the needed items.
- It can be implemented with minimum distraction to the adjacent production lines.



**Figure 21: Saved Area Utilization for Design A**

## **7.6 Improvement of the Final Layout Design**

### **7.6.1 Iteration one**

The team verified the new layout on the floor. Special attention was paid to ensure safety distances from emergency exit, aisle distance met the company's safety requirement and no safety hazard present in the proposed design. Modifications were also made to address production associates' concern in operation and safety. New constraints and opportunities were revealed by discussion with each production associates.

### **7.6.2 Iteration two**

After meeting with quality engineer and technician, the team found out that quality assurance after rearrangement may take considerable time and efforts. Equipment and critical processes that were to be moved had to be calibrated and pass quality assurance in order to ensure product quality in new layout. The amount of work can be reduced if the new layout required minimum movement. The team made one round of design review to reduce movement requirement in the new design. One key finding is that the process flow of catheter subassembly in the current layout goes from row 3 to row 1. The revised design can keep row 3 unmoved and move row 2 and row 1 to the other side of the design while not disrupting the continuous process flow. This modification reduced the number of equipment for quality assurance by leaving row 3 unchanged.

### **7.6.3 Iteration three**

The utility department was involved in final review meeting to ensure utility was available on actual movement day. One issue raised was that relocation of ventilation system from the ceiling required capital investment and manpower. Currently ventilation system was used in row 5 for fume hoods to extract chemicals. In order to reduce capital investment, the team reviewed the design and switched the syringe and accessory subassembly lines with the sheath subassembly so that the fume hoods can be connected to ventilation system without any extension or modification. This proposal was justified with quality department and utility department during a walkthrough meeting. The company was convinced that the rearrangement required minimum investment and potential risks.

## **7.7 Implementation Package**

Prior to implementation, the team proposed an implementation package for each department to review the technical aspects as well as their individual responsibility in implementation. The implementation package was attached as an Appendix. The implementation package contains the following documents:

### **Bench Labeling**

Provided the numbering system for the current layout and the new layout. One can locate any bench or equipment movement using the numbering system. Drawings of the current layout and new layout in the numbering system were also provided.

### **Movement Summary**

Summarized the critical movement and changes within the line, for example, removal of equipment and benches, change of bench sizes and relocation of non-production items.

### **CAD drawings of existing and proposed layout with dimensions**

Detailed drawings with dimensions for utility department to understand the new locations of each row and also verify safety distances.

### **Purchase List**

A list of needed items for the movement. This includes small benches, bin rails for storage of raw material inventory and new equipment.

### **Supermarket Replenishment Strategy**

A detailed strategy for warehouse to implement replenishment after decentralizing the supermarket. It described standard work for warehouse personnel and production associates' responsibility to place Kanban cards onto the visual management cube. New Kanban cards were also attached with color coding.

### **New Layout Bench Details**

A detailed description of each bench. It included the operations performed on a bench, bench size, equipment arrangement on a bench, asset list and bins on the shelf. Utility and technicians can arrange the benches based on new layout bench details and use it as a checklist after movement.

## **8. Development of Visual Management**

This chapter discusses the development process of visual management system. Key performance indicators were obtained through interviews and conversations with various stakeholders. Management tools were developed to track different aspects of production activity and encourage engagement in system improvement.

### **8.1 Identification of Key Performance Indicators**

#### **8.1.1 Key Stakeholders Identification**

Visual management system indicates the line status, especially signaling for on-track and off-track production activities. It is also a communication tool to get people involved in continuous improvement of the line and escalate issues to the proper level. As an information facilitation tool, it is crucial to identify the key stakeholders so that the system is tailored to serve the objective of each stakeholder. The key stakeholders for the production line are:

##### **The production associates**

They are directly involved in production activity on daily basis. They are the key to success in implementing visual management tools on the floor. In addition, since they have the most hands-on experience and knowledge on the line itself, encouraging them to be involved in continuous improvement would benefit the production system in long run. As they are the major user of visual management tools and because of their busy production target, the tools should be designed to be easy to use without much additional training.

##### **The management team**

This includes mainly the manufacturing manager and the line supervisor. Both of them are responsible for the performance of the line, in terms of production rate, product quality and waste elimination. Because they supervise several production lines, it is important to have the visual management tools concise and keep only to the essential indicators. Consistent format with visual tools from other production lines increases their acceptance.

## **Other parties**

Other parties are not directly involved in the production line, rather facilitating production, such as warehouse department and quality department. They show up to the floor once or twice a day and deliver service to the floor. They have some knowledge in the line and are particularly interested in one aspect of the business, inventory management for warehouse, for example. Getting them updated with latest news on the floor could be beneficial to enforce the integration of whole system.

### **8.1.2 Company's Engagement**

The visual management system was not supposed to be a 6-month project, but instead an initiative to be adaptable and useful for the line for years. If the stakeholders did not feel involved or needs and desires were not expressed, this project could have been discarded and success in jeopardy. Therefore, it was important to impart a sense of ownership over the tool in the short period of time. With a strong involvement from each party, the project would then bring value to the company and continuous improvement of the tools could make it valuable and continued to be used.

Owing to the company's ongoing lean education, the concept and benefit of visual management system has been spread across the company. Managers attended lean manufacturing workshops and some visual management initiatives have taken place on other lines. Therefore, the management team was supportive of this project, providing necessary resources to carry out this project. The production team showed acceptance to the nature of the project. However, in order to push this project one step further, acceptance was not enough. Personal involvement of the team was required. Ownership was established from the beginning of the project through conversations and formal meetings to discuss what is important to the production floor and what do they care about in understanding the performance of a day. Developing tools by getting inputs from the production associates and addressing concerns they addressed, the tools were evolving towards their ideas and the production associates felt they were part of the team and they had their voices heard and valued.

### 8.1.3 Key Performance Indicators

Through informal conversations and meetings with managers and production team, the key performance indicators were identified. The production associates had good knowledge in all aspects of production activity. However, they were not able to convert the key factors into objective number terms. Questions were asked to help them identify key performance indicators. Several sample questions were:

1. What are the numbers you report to your boss?
2. How do you know whether the line is working well?
3. What are the key factors affecting the quality of this product? Can they be quantified?

Based on the results from meetings, key measures of business aspects were identified and they were quantified for more objective measurement using the performance measure discussed in Chapter 4:

**Table 7: Key Performance Indicators Identified in this project**

Key Performance Indicator	Measure of	Expression
Production Rate	Productivity	Units produced per hour/day
Yield	Quality	Number of units produced correctly/total number of units produced
Cycle Time	Lean	The time one batch/unit of product spent on the floor
Accumulative Production	Effectiveness	Accumulated number of units produced vs total demand on the same time horizon
Suggestions Proposed	Engagement	Number of suggestions proposed

Production rate is the direct indicator of the efficiency of production activity on the floor. It is usually snapshot on hourly or daily basis. It shows the number of finished product at the end of

the time horizon. High production rate represents efficient production and less machine downtime. Low production rate causes problems in meeting customer demand and requires attention to identify production bottleneck in order to expedite production.

Yield is of equal importance compared with production rate. It represents the percentage of certified units produced to the total units. Multiple of production rate and yield gives the actual production rate for products that can be shipped to customers. It also measures the correctness of production operations performed on the line. A high yield converts large percentage of resources into correct product with little wastage. In modern manufacturing activity, quality acts as a key factor of cost saving and adds to customer satisfaction level. Low yield unveils lack of standard work procedure and improper machine operations.

Cycle time measures the latency of a product to be within the manufacturing system. Two major time periods associated with cycle time are the time that a unit is processed on the line (touch time) and the waiting time a unit spent on the floor as work-in-progress inventory before it becomes finished product. The waiting time is due to down stream process being occupied or due to waiting for a batch process. The only value-adding time for one unit is the touch time, waiting time accumulates inventory between processes, increasing capital tie-up in the system. By monitoring cycle time, the production team is able to understand the production cycle and the number of parts waiting in the line, thus identifying opportunities to smooth material flow. More detailed discussion on Cycle time can be obtained from Peterson's thesis [1].

Although production rate is a good indication of parts produced on short time horizon, an order usually comes in large quantity which requires production planning and weeks of production. As production rate fluctuates, it is important to track the cumulative number of products produced as compared to planned production. It is an indicator for production planning in understanding production status. Productivity can be freed up if cumulative production is higher than planned and additional shift may be needed if cumulative production is lagging behind.

Engagement of production team can also be quantified by the number of suggestions proposed per month. The whole production system can benefit from suggestions implementation. This assessment motivates production team to be involved in problem identification and leverage their knowledge in problem solving. Management team can use this indicator to assess team morale and engagement.

## **8.2 Design of Inventory Replenishment Management tool**

As mentioned in Chapter 7, the supermarket was to be decentralized to the point of use on respective shelf of benches. Previously a warehouse person collected Kanban cards at the supermarket every afternoon when inventory was low. Since Kanban cards are now to be distributed on the whole floor with each inventory bin, the warehouse person has to walk around every bench to collect Kanban cards. This increases the amount of work for the warehouse personnel and creates potential risk of missing some Kanban signals. As a result, a new replenishment strategy has to be developed to accommodate the new layout. The objective of an inventory replenishment management tool is to integrate Kanban system with the visual management system to notify the warehouse person and production associates about all parts to be replenished, thus increasing replenishment efficiency and information transparency.

The replenishment management tool is made of a white board on a rotating cube. A magnet is attached to each Kanban card, thus Kanban cards can be attached to the replenishment management tool. By doing this, Kanban cards from empty bins can be all collected on the white board. The warehouse personnel can then get all Kanban cards from the white board and make delivery on the next morning according to the information on each Kanban card. As the warehouse personnel comes to the floor at 3pm everyday to collect Kanban cards, it is required for each worker to be responsible to place Kanban cards to the replenishment management tool when they need more parts for production next day. In order to ensure all Kanban cards are placed on time, the line lead on the floor is recommended to check inventory of each material before 3pm. The idea of standard work for production associates and line lead was communicated with the production team. It was estimated that it took less than 2 minutes for



production associates to put Kanban cards onto the inventory replenishment management tool and it took the line lead less than 5 minutes to check the all inventory at the end of a shift. Detailed discussion of the replenishment strategy was covered in Yang’s thesis [3].

Raw Material Replenishment Tool		
<u>Note:</u> Place kanban cards of low inventory raw materials onto this area at the end of the shift.		
Kanban Cards	Kanban Cards	Kanban Cards
Kanban Cards	Kanban Cards	Kanban Cards
Kanban Cards	Kanban Cards	Kanban Cards
Kanban Cards	Kanban Cards	Kanban Cards

**Figure 22: Template of Raw Material Replenishment Tool**

The template in Figure 22 has been attached onto the rotary cube. Production associates placed Kanban cards onto the dedicated place shown as “Kanban Cards” on the template. The benefit of this visual tool for the production team is that they are engaged with inventory replenishment, as they are motivated to ensure enough inventory for the next day. They welcomed such activity as a getaway from production activity for a short period everyday. In addition, since all visual management tools are placed at one location, the replenishment management tool will bring them to the visual management cube to get engaged with other management tools, encouraging them to be more involved to visual management. The other stakeholder of this tool, the warehouse person also embraced this idea. He is able to get all

Kanban he needs right away as Kanban cards are collected on the tool before he goes to the floor. The management team could be able to know the number of parts needed to be replenished by taking a glance at the Kanban cards attached to the replenishment management tool efficiently.

### **8.3 Design of Kaizen Tool**

One of the objectives in this project is to develop a system to encourage production team and management team to be continuously engaged in problem solving and system improvement. One of lean techniques, kaizen, shares the same philosophy. A successful kaizen tool serves two main purposes: escalating an issue or a suggestion for an improvement to the appropriate level for attention and actions. An issue occurs to impede a job function or put a metric at risk of failure. Suggestions for improvement identify potential project to enhance production performance. Elimination of issue and implementation of improvement would make the production activity more efficient and hazardless. Therefore, it is of the company's benefit to adopt kaizen tool to smooth operation.

A kaizen tool template from the company was modified for the production line to be posted and displayed in the work area. One kaizen card consists of two sections, each of which requires one party to fill in. Section one is to be filled by the requestor and it contains requestor's department, the requestor's name, date requested, date needed if the action has a certain deadline, a short description of the issue and recommended fix if the requestor has a possible solution. The short description and recommended fix should be as specific as possible, including the part number and affected personnel. Section two is to be filled by the department board owner. In this section, it contains the name of the resource assigned to the project, plan due date estimated by the resource, estimated completion date, actual completion date, resolution and card status. Once a resource is assigned to the issue, he should discuss the issue with the requestor and make a plan to move forward. The status of the project should be indicated using color code on card status.

In order to keep track of all kaizen cards, triplicate copies should be made for each kaizen card with different colors. The white copy remains on the visual management cube where the requestor filled in the card. All white copies of ongoing projects should be collected on the kaizen area on the cube. All updates to the card including plan dates and status changes should be made to the white copy. Yellow copy is given to the assigned resource for his reference. The requestor keeps the pink copy once he completes section one. The pink copy goes into the work center board as an archive of all kaizen projects completed. It is recommended that all accomplished kaizen cards to be posted to inform the company of the achievements and give credits to requestors.

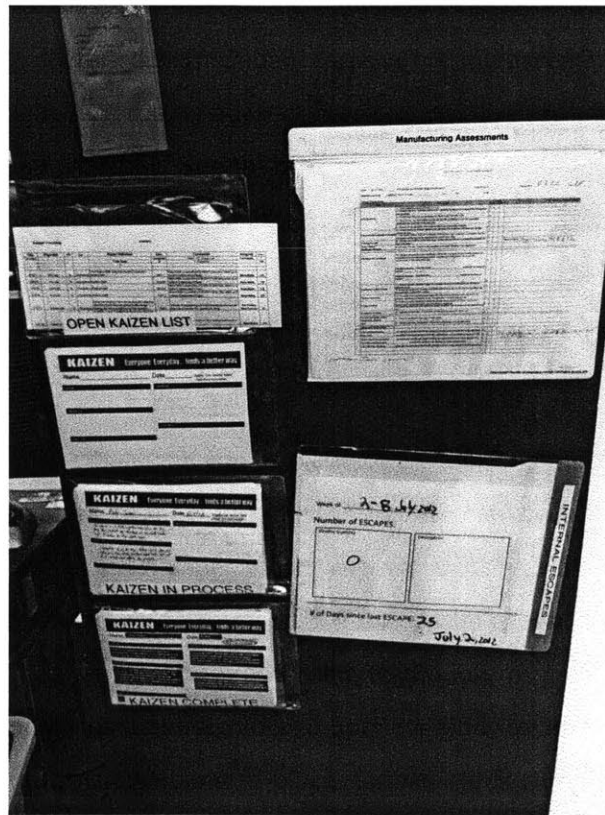


Figure 23: Generic example of Kaizen Tool

## **8.4 Design of Production Performance Tool**

As a medical device production line, production rate and product quality are of great importance to the business. A production performance tool will keep the management team informed with the line status and focus on production planning.

Previous daily production rate was recorded in a log sheet with batch size and number of rejects. It contained all essential information that people concern, however, it required people to read through lines in order to understand the status. In addition, only the production of the catheter was recorded on the log sheet, not the other subassemblies. As a result, a revamped production performance tool was created to provide more visualization and include the status of all subassemblies. Because each subassembly is manufactured as a batch, taking several hours to finish, it is reasonable to create the performance tool to track daily production instead of hourly. Better visualization requires displaying only essential information in a concise form. The revised production performance tool recorded the daily production rate, the yield percentage and batch number. The production associate who did the final inspection was responsibility to record the information to the visual manage cube.

A line chart was developed to track the cumulative production in a week. The planned weekly production was presented as a straight line with the target production rate. The actual cumulative production would be drawn onto the chart every day. The difference between actual and planned production helped the management team to assess line performance and make judgment on the production plan the next day or whether additional manpower was required.

Start Date	Batch Number	Batch Size	End Date	Cycle Time	CT>5	CT<5

Figure 24: Production Performance Tool

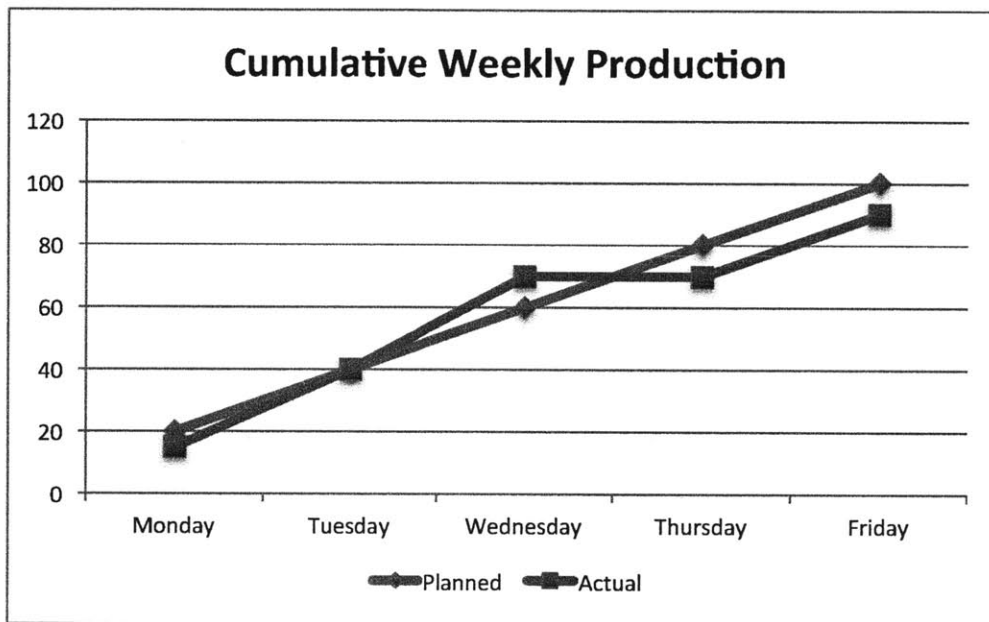


Figure 25: An Example of a Weekly Cumulative Production Chart

# 9. Conclusions and Future Work

## 9.1 Conclusions

Five aspects of manufacturing system, namely floor area reduction, cycle time, inventory, manpower management and visual management were studied to improve system efficiency in this project. This thesis discussed the development of new floor area reduction and visual management as referred to in Chapter 2.

The final floor layout design saved 476 ft<sup>2</sup> in the production area while maintaining the same production rate. A total of 10 six-foot benches along with the required safety distances can fit in the saved space. Therefore, company could introduce a new production line on the floor. It required minimum change from the current bench configuration, keeping process flow continuous and minimum purchase required. The implementation of the new layout is expected to be early August.

Visual management tools were developed by first studying the manufacturing system, understanding performance parameters associated with the system, then identifying the stakeholders of the system, involving them in discussions to identify key performance indicators. Those key performance indicators were designed according to SMART framework to be specific, measurable, actionable, relevant and timely. Various visual management tools were designed to benefit the system performance in inventory management, continuous improvement and production tracking. These tools were reviewed with all stakeholders. Standard work and responsibility in managing each tool was assigned to appropriate party in future operation.

## 9.2 Lesson Learned

There is synergy between new floor layout design and visual management design. They were not independent projects but rather complimenting to each other. As a point of use supermarket system was set up in the new layout, a new inventory replenishment strategy was required to ensure smooth material delivery from warehouse to the floor. An inventory replenishment management tool was developed to visualize the inventory level on the floor

and adopting a Kanban system to signal replenishment. It facilitates communication between warehouse and the production team and also reduces the potential risk of implementing the new layout design.

The result of floor reduction and visual management on the floor were both contributing to improvement of system efficiency in the company. Floor reduction enabled the line to produce the same number of products with less space, thus increasing the utilization of space and reducing the cost of land. Visual management, as an execution tool for connecting daily management activities to achieving strategic objectives, ensured production activity to stay aligned with the company's benefit and enhance management effort on the production line, in turn increasing the integration of the system. The complexity of a system in a manufacturing plant requires not only improvement of one aspect but rather analyzing all aspects of its production activities.

### **9.3 Recommendations for the Company**

Engagement of all stakeholders is crucial to the success of this project. Without engagement of humans, a system cannot be operated at its full capacity. Humans have the knowledge in the system and act as the inspiration source and implementer of system improvement. Therefore, human engagement unleashes the full potential of this project. With the importance being said, in a project that requires change in a system, it requires considerable time and efforts to get people involved and convince people to change. Without a strong culture of continuous improvement, people may be more resistant to changes and difficult to be convinced that there are things that can be improved. Acceptance can be nurtured by frequent communication and a sense of ownership of this project to the production team.

In the future, work with the scheduling team would be helpful. Two production planning signals sent to the production line was observed: a weekly production plan is published to the production line while a Kanban system was also used to signal production. The redundancy caused confusion in communication between the packaging department and production department. The two systems should be consolidated to improve the planning efficiency and reduce finished goods inventory level on the floor.

## **9.4 Future Work**

As a future step, the use of equipment and fixtures in the production line can be reviewed and new equipment and fixtures could be designed to reduce the space required due to the length of the product itself. The product is current being laid horizontally on benches during operations. Vertical orientation could significant reduce the space required. The line was designed in a way that each operation has its dedicated equipment. This is not necessary as the number of production associates is much less than the number of operations. More consolidation of equipment or redesign of process flow could further reduce the space. However, this requires a thorough review of the procedure of operations, large investment in purchases and may involve FDA revalidation.

Although the project has produced convincing results of improvement, periodic review of the manufacturing system is required to be engaged in continuous improvement and tackle new challenges under new circumstances. The final floor layout design provided moderate flexibility in production. In the future, this needs to be reviewed to meet the market demand. Key performance indicators need to be in sync with the company's evolving strategy and priority. With more knowledge learned in the new layout and implementation of visual management, the management team and production team will be able to suggest improvements to the system.

Also, assessing the effectiveness of visual management tools could be an interesting topic. Visual management tools were deployed to provide quantified key performance indicators, align sector objectives to sites goals, facilitate daily management activities in production, signal for abnormalities and engage human resource in continuous improvement. Metrics can be developed to assess the benefit of each tool to system performance. A close study on the information flow using visual management tools can be conducted to make a comparison with the information flow without tools to understand its impact on system-human interaction. Organizational factor and cultural factor can be discussed to find the best environment for visual management.



# REFERENCES

- [1] Peterson, J., (2012). "Production System Improvement: Floor Area Reduction and Cycle Time Analysis" S.M. thesis, Massachusetts Institute of Technology, Cambridge, MA
- [2] AlEisa, A., (2012). "Production System Improvement: Floor Layout Reduction and Manpower Analysis" S.M. thesis, Massachusetts Institute of Technology, Cambridge, MA
- [3] Yang, T., (2012). "Production System Improvement Floor Area Reduction and Inventory Optimization" S.M. thesis, Massachusetts Institute of Technology, Cambridge, MA
- [4] Krafcik, J., 1988, "The Triumph of the Lean Production System," *Sloan Management Review*, vol. 30, pp. 41-52.
- [5] Black, J. T., 1999, *Factory with a Future*, McGraw-Hill.
- [6] Womack, J.P., Jones D.T., 2003, *Lean Thinking*. 1<sup>st</sup> ed., Free Press: New York, NY, pp. 56.
- [7] Womack, J.P., Jones D.T., 2003, *Lean Thinking*. 1<sup>st</sup> ed., Free Press: New York, NY, pp. 16.
- [8] Motorola University,  
[https://mu.motorola.com/six\\_sigma\\_lessons/contemplate/assembler.asp?page=history\\_been\\_around](https://mu.motorola.com/six_sigma_lessons/contemplate/assembler.asp?page=history_been_around), accessed July 19, 2012.
- [9] Motorola University,  
[http://www.motorola.com/web/Business/\\_Moto\\_University/\\_Documents/\\_Static\\_Files/What\\_is\\_SixSigma.pdf](http://www.motorola.com/web/Business/_Moto_University/_Documents/_Static_Files/What_is_SixSigma.pdf), accessed July 19, 2012.
- [10] Barney, M., 2002, "Motorola's Second Generation," *Six Sigma Forum Magazine*, pp. 13-16.
- [11] Montgomery, D.C., 2008, *Introduction to Statistical Quality Control*, 6<sup>th</sup> ed., Wiley.
- [12] Furterer, S.L., 2009, *Lean Six Sigma in Service: Applications and Case Studies*, CRC Press, Chapter. 2.

- [13] Dubai Quality Group, 2003, "The Birth of Lean Sigma," *The Manage Mentor*, Dubai.
- [14] Hindo, B., 2007, "At 3M, A Struggle Between Efficiency and Creativity," *Businessweek*.
- [15] Chakravorty, S.S., 2010, "Where Process-Improvements Go Wrong," *Wall Street Journal*.
- [16] Company Internal Resource
- [17] Lawler, M., 2010, "Improving Shop Floor Visualization and Metrics," S.M. thesis, Massachusetts Institute of Technology, Cambridge, MA
- [18] Couzens, S., (2006). "The DNA of a High-Performing Manufacturing Organization: Using Performance Measurement to Improvement Operations Capability." S.M. thesis, Massachusetts Institute of Technology, Cambridge, MA
- [19] Anupindi, R.e, (2006). "Managing Business Process Flows: Principles of Operations Management." Upper Saddle River, NJ: Pearson/Prentice Hall
- [20] McCaghren, N., (2005). "Enabling Process Improvement through Visual Performance Indicators." S.M. thesis, Massachusetts Institute of Technology, Cambridge, MA.
- [21] Training Resources and Data Exchange (TRADE). (1995, October). "How to Measure Performance: A Handbook of Techniques and Tools." Oak Ridge Associated Universities.
- [22] Wolbert, D., (2007). "Utilization of Visual Metrics to Drive Intended Performance" S.M. thesis, Massachusetts Institute of Technology, Cambridge, MA

# APPENDIX

## Asset List

Description	Asset Number	Dimensions	Old Bench	Model #	New Bench
Oven for Balloon	TD532820	27.5*25.25*35	1.1	1.1.1	N3.1
Microscope	126736	13*29*20	1.1	1.1.2	N3.1
Laser Micrometer	TD581101	24.375*9*9.5	1.1	1.1.3	N3.1
Four Fixtures for Balloon	EQ1400C-F	8*13*8	1.1	1.1.4	N3.1
EFD	EQ12400		1.1/1.2		N3.1/N2.3
Sander	EQ12361		1.2		N3.2
Ultrasonic Cleaner	EQ1242I	13*12*11.75	1.2	1.2.1	N3.2
Blow Machine	EQ1237K	9.875*6*7.875	1.2	1.2.2	N3.2
Blow Machine	E-630	9.875*6*7.875	1.2	1.2.3	N3.2
Panel on top of Blow Machine	TD53381A	11.125*8.25*4	1.2	1.2.4	N3.2
Microscope	100301	13*29*20	1.2	1.2.5	N3.2
Blow Machine	E-630	9.875*6*7.875	1.2	1.2.6	N3.2
Panel on top of Blow Machine	TD53541A	11.125*8.25*4	1.2	1.2.7	N3.2
Spare Part for Fixture		8*14*4	1.2	1.2.8	N3.2
Microscope Base	EQ2252B	24*18*18	1.3		N3.3
Microscope Base	EQ2252C	24*18*18	1.3		N3.3
Yellow Equipment	EQ2423D	6*6*18	1.3		N3.3
Novacure Machine	EQ1464C	17*11*6	1.3		N3.3
Novacure Machine	EQ1464D	17*11*6	1.3		N3.3
Microscope with fixture A	89132	32*18*16	1.3	1.3.1	N3.3
Microscope with fixture B	126728	32*18*16	1.3	1.3.2	N3.3
Yellow Equipment	EQ2423B	6*6*18	1.4		N3.4
Microscope	126676	13*29*20	1.4	1.4.1	N3.4
Laser Micrometer	TD58110V	24.375*9*9.5	1.5	1.5.1	N3.5
Tool Box		17*11*11	1.5	1.5.2	N3.5
Nikon Measurescope		17*13*22	1.6	1.6.1	N3.6
Panasonic Image Equipment		20*10.5*12	1.6	1.6.2	N3.6
Ram Optical with Computer	EQ1256D	36*30*34	1.7	1.7.1	N3.7
Microscope with a fixture	126621	24*18*17	2.1	2.1.1	N2.1
Novacure Machine	EQ1464G	17*11*6	2.1		N2.1
Yellow Equipment		6*6*18	2.1		N2.1
Fixture	EQ2252D	24*18*16	2.1		N2.1
Microscope	126677	13*29*20	2.1	2.1.2	N2.1
Volume Static Eliminator	SDC011	13.5*11*10	2.1	2.1.3	N2.1
Heater	EQ2258C	6*14*4	2.2		N2.2

Description	Asset Number	Dimensions	Old Bench	Model #	New Bench
Microscope	126734	13*29*20	2.2	2.2.1	N2.2
Microscope	126662	13*29*20	2.2	2.2.2	N2.2
Blow Machine	EQ1237F	9.875*6*7.875	2.2	2.2.3	N2.2
Blow Machine	EQ1237I	9.875*6*7.875	2.2	2.2.4	N2.2
Laser Micrometer	TD58110N	24.375*9*9.5	2.2	2.2.5	N2.2
Proofloader	58075	48*22*21.5	2.3	2.3.1	N2.3
Microscope	100294	13*29*20	2.3	2.3.2	N2.3
Microscope Base	TD54093A	14*10*15	2.4		N2.4
Microscope	126668	13*29*20	2.4	2.4.1	N2.4
Microscope	126738	13*29*20	2.4	2.4.2	N2.4
Microscope		13*29*20	2.4	2.4.3	N2.4
Seal Insertion Machine	126888	32*24*26	2.5		N2.5
Chatillon	TD54887	9*4*2	2.5		N2.5
Microscope+Machine	126675	41*25*27	2.5	2.5.1	N2.5
EDM Machine	TD5325IB	26*26*39	3.1	3.1.1	N1.1
Medical Waste Container		diameter: 17* height: 20	3.1	3.1.2	N1.1
Pressure Regulaor	EQ1253E	7*8*4	3.2		N1.2
Sander	EQ1236B	6*6*7	3.2		N1.2
Microscope	126729	13*29*20	3.2	3.2.1	N1.2
Microscope	126735	13*29*20	3.2	3.2.2	N1.2
EDM Control Panel	TD5325IB	12.25*17*18	3.2	3.2.3	N1.2
Ultrasonic Cleaner underneath the table	USC 169	22*31*18	3.2	3.2.4	N1.2
Alcohol-Air Supply	TD55786A		3.3		N1.3
Automatic Cleaner	EQ1477A	14*10*5	3.3	3.3.1	N1.3
Flushing Patency Space	EQ1305B	33*24*74	3.4	3.4.1	N1.4
Laser meter	TD58110F	24*7*10	3.5	3.5.1	N1.5
Plastic Fume Hood (thicker)	x	24*9*14	3.5	3.5.2	N1.5
Humidifier	AOS001	14*7*18	3.5	3.5.3	N1.5
Microscope	126764	12*24*18	3.5	3.5.4	N1.5
Equipment	EQ1240L	7*6*12	3.5	3.5.5	N1.5
Acids and Corrosives		20*18*21	3.6	3.6.1	N1.6
Waste Rejected		24*16*18.5	3.6	3.6.2	N1.6
Microscope in a fume hood	126181	24*11*14	4.1	4.1.3	N5.3
USC	USC 160	13*12*11.75	4.1	4.1.4	N5.3
Laser Micrometer	TD581101	24*9*14	4.2	4.2.1	
Humidifier	AOS002	14*7*18	4.2	4.2.3	N5.4
Microscope in a fume hood	126664	36*19*19	4.2	4.2.5	N5.4
Shape Plug a	EQ1280B	23*14*8.5	4.3	4.3.1	N5.4

Description	Asset Number	Dimensions	Old Bench	Model #	New Bench
Microscope	126730	13*29*20	4.3	4.3.2	N5.4
Shape Plug b	EQ1453A	12*20*14	4.3	4.3.3	N5.4
Gra Lab 545	N/A	10*4*5	4.4		N6.1
Epoxy Gray Box	EQ1240E		4.4		N6.1
Air Blower	126619	12*10*8	4.4	4.4.1	N6.1
Introducer Sheath a		27*18*13	4.4	4.4.2	N6.1
Introducer Sheath b		15.5*7*10.5	4.4	4.4.3	N6.1
Introducer Sheath c		14*7*18	4.4	4.4.4	N6.1
Introducer Sheath AB			4.4	4.4.5	N6.1
Fiber Optic Illuminator	N/A	7*5*8	4.5		N6.2
Introducer Sheath 2a	TD52533A	15.25*9*21	4.5	4.5.1	N6.2
Introducer Sheath 2b		24*22*14	4.5	4.5.2	N6.2
Introducer Sheath 2c		8.5*8.5*3	4.5	4.5.3	N6.2
Plastic Fume Hood	x	24*16*16	5.1	5.1.1	N4.3
Ultrasonic Cleaner	TD53862B	13*13*12	5.1	5.1.2	N4.3
Press Machine	EQ20871	6*10*19	5.1	5.1.3	N4.3
Epoxy Black Tower, w/o Base	EQ1240G	3*6*11	5.1	5.1.4	N4.3
Epoxy Black Tower, w/ Base	EQ1240A	7*6*12	5.1	5.1.5	N4.3
Plastic Fume Hood	x	24*16*16	5.2	5.2.1	N4.2
UV Curing Machine	TD51436B	54*18*27	5.2	5.2.2	N4.2
Plastic Fume Hood	x	24*16*16	5.3	5.3.1	N4.1
Slider Pad and Mid Pad	EQ1274D,E	8*6*4	5.3	5.3.2	N4.1
Black Machine	EQ 1240U	7*6*12	5.3	5.3.3	N4.1
Plastic Fume Hood (thicker plastic)		24*12*14	5.3	5.3.4	N4.1
Press Machine	TD538221/01	6*10*19	5.5	5.5.1	N5.2
Plastic Fume Hood	x	24*16*16	5.5	5.5.2	N5.2
Testing Equipment	EQ1256G	20.5*20.5*26	6.1	6.1.1	N4.6
Accessories for Testing Equipment	na	7*9.5*7	6.1	6.1.2	N4.6
Inspection Computer and Monitor	na	36*30*18	6.1	6.1.3	N4.6
Fume Hood	na	28*11*14	6.2	6.2.1	N4.5
Air Supply/ Press Control	EQ1253C	7*7.5*4	6.2	6.2.2	N4.5
Equipment	EQ1465A	24*6.5*4.5	6.2	6.2.3	N4.5
Equipment Inside the UV Bonding	EQ2449A/ EQ1496A	8*9*9	6.3	6.3.1	N4.4
UV Bonding	UVH001	21*16*12	6.3	6.3.2	N4.4
EFOS Acticure	EQ1241C	12*11*6	6.3	6.3.3	N4.4
Pressure Control above UV Bond	EQ1253A	7*7.5*4	6.3	6.3.4	N4.4

Description	Asset Number	Dimensions	Old Bench	Model #	New Bench
Equipment	EQ2170A	14*14*11	6.3	6.3.5	N4.4
Top Gun on Stand Support	TD58103	5.5*4*7.5	6.3	6.3.6	N4.4
Pressing Machine	EQ2087A	7*12*17	6.4	6.4.1	N4.4
Pressing Machine	EQ2087B	7*12*17	6.4	6.4.2	N4.4
Pressing Machine	TD 129877A	7*5*15	6.4	6.4.3	N4.4
Fume Hood "Thick"	NA	30*9*14	6.4	6.4.4	N4.4
Top Gun Shelf	TD50653C	7*5*5	6.4	6.4.5	N4.5
Small Press Over the Shelf	EQ 2251A	2.5*6*4	6.4	6.4.6	N4.5
Small Press Over the Shelf	EQ 2251B	2.5*6*4	6.4	6.4.7	N4.5
Small Press Over the Shelf	TD53738A	2.5*6*6	6.4	6.4.8	N4.5
Small Press Over the Shelf	TD53738B	2.5*6*6	6.4	6.4.9	N4.5
EFD 2000 XL on Fume Hood	EQ1274	7.5*6*3	6.4	6.4.10	N4.5

### Existing and Proposed Floor Layout with Dimensions:

Figures 3 and 4 show the existing versus the proposed layouts along with their critical dimensions.

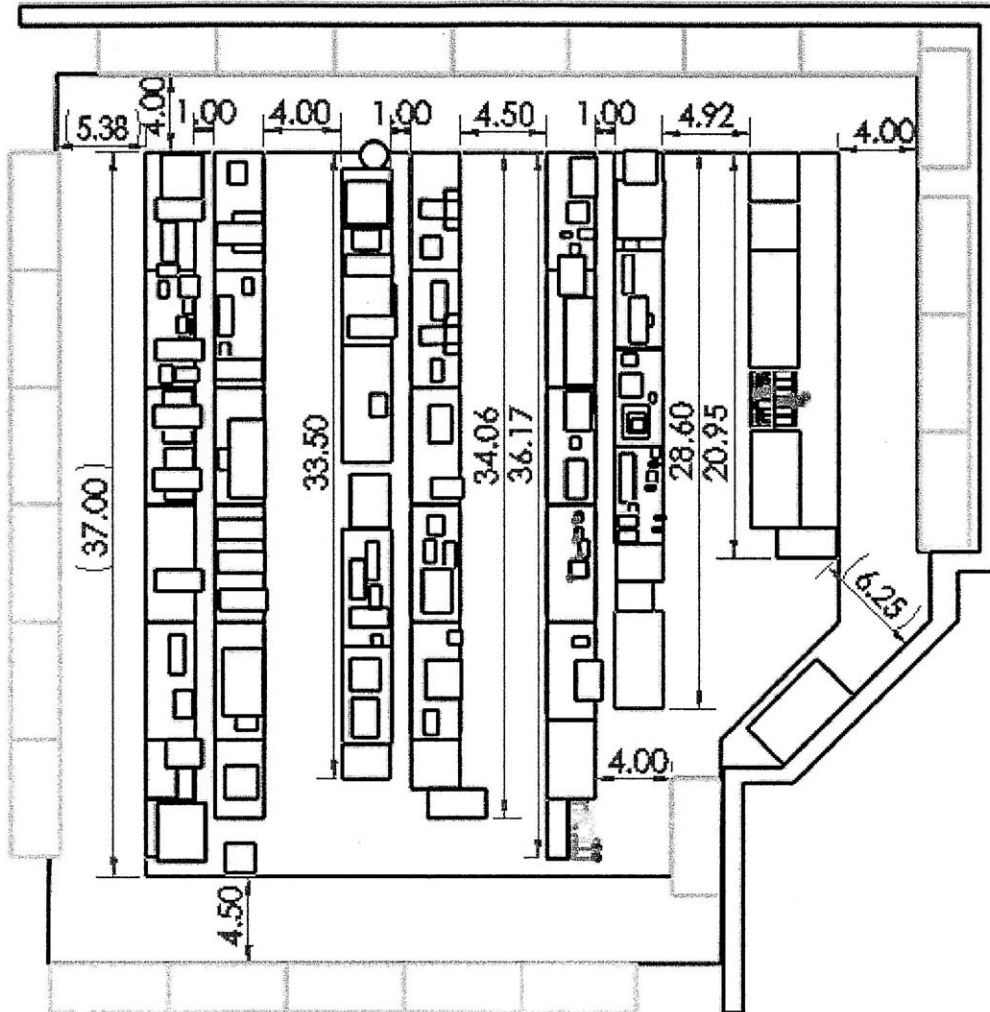


Figure 26: Current Floor Layout with Major Dimensions

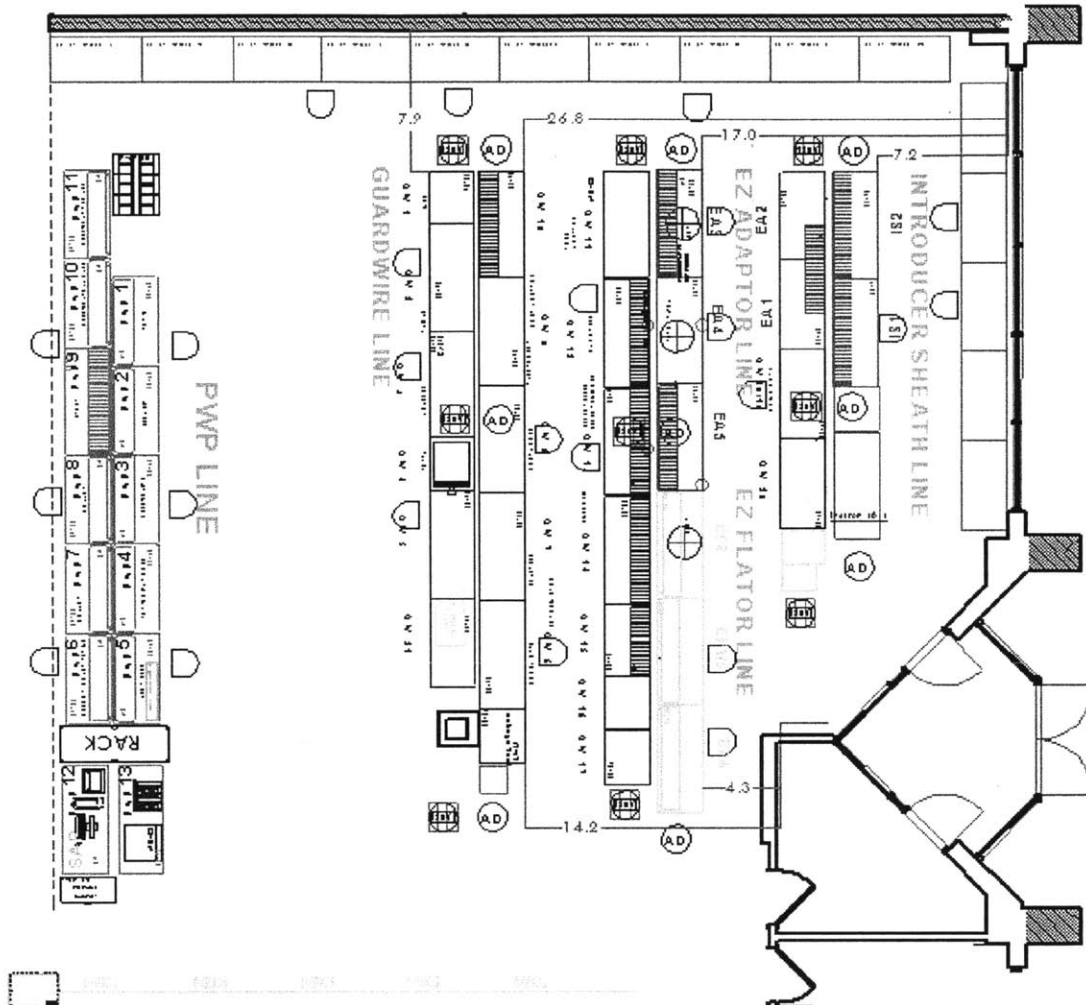


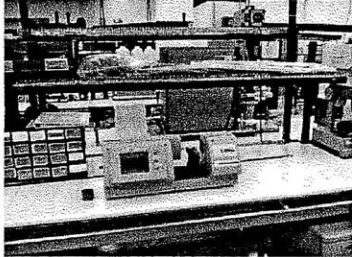
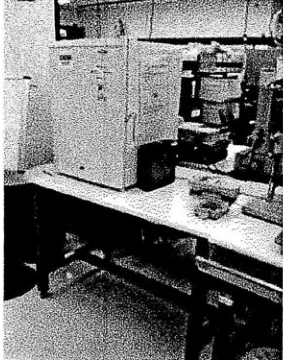

Figure 27: Proposed Floor Layout with Major Dimensions

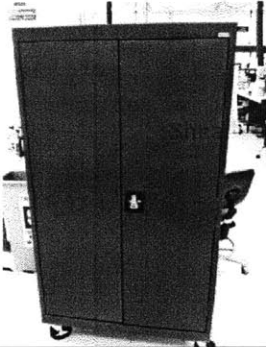

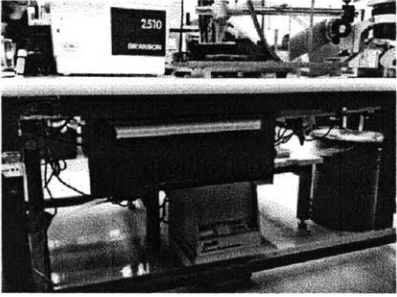




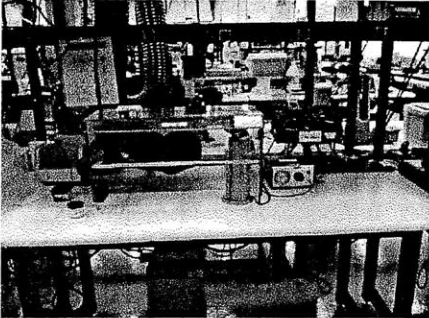
## Movements Summary




Refer to Figures 26 and 27 for the existing and new layout of the production floor. Moreover, Table 8 documents the changes that will take place on the affected benches (other than changing the location). The bench number column refers to the current layout grid numbers as seen in Figure 12.


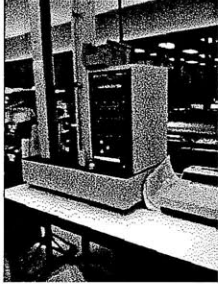

**Table 8: Changes on Affected Benches**


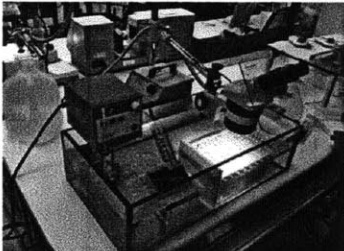
Item Description	Production Line	Bench No.	Action	Picture
Bench	Catheter	1.5	Replace the 6 ft bench with a 4 ft one.	
Fridge	Catheter	2.6	Combine it with the fridge at the coating room and eliminate its bench.	
Bench	Catheter	4.2	Replace the fume hood with a cone to be located on 4.3 and remove the 6ft bench (4.2) (Suggested by Anh During the walkthrough)	

Item Description	Production Line	Bench No.	Action	Picture
Working benches	Catheter	4.1/4.3	Replace these two benches (6ft) with two 5ft benches.	Refer to Figures 1 & 2.
Cabinet	Sheath	4.7	Decentralize the content of the cabinet to 2 small drawers to be placed underneath bench (N4.2)	
Fume hoods	The accessory production line	5.5	Combine the fume hood with the one at 5.1.	
Bench	The accessory production line	5.4/5.5	<p>Replace the 6ft bench (5.4) with a 5ft one.</p> <p>Relocate the benches 5.4 and 5.5 to their new locations shown in Figure 2 (N5.1 and N5.2 respectively)</p>	

Item Description	Production Line	Bench No.	Action	Picture
Computer Desk	The accessory production line	5.6	Replace it with the other computer desk (6.5) and relocate this desk to row 6 as shown in figure 2 (N6.3).	
Catheter Supermarket	The accessory production line	5.7	Decentralize the supermarket by relocating the bins to be at the catheter's benches as detailed in the benches details section.	
Fume hood	The syringe production line	6.2	Remove the fume hood and utilize the one on bench 6.4.	
Working benches	The syringe production line	6.1/6.2 /6.3/6.4	Replace a total of four 5ft benches with three 6ft ones	Refer to Figures 1 & 2.



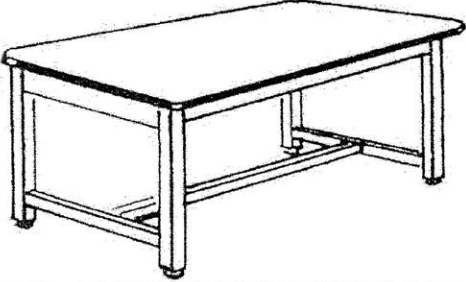
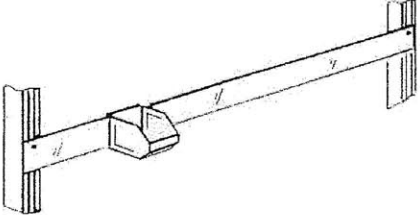
Item Description	Production Line	Bench No.	Action	Picture
Cabinets (2EA)	The syringe production line	6.7	Move them to the technician's area	
Computer desk	Supermarket	7.2	Relocate it to be outside the floor.	
Finished goods inventory	Supermarket	7.3	Take away the shelves and relocate the boxes (8 EA) to be underneath benches of the tensile test equipment and inspection bench (N4.6)	

Item Description	Production Line	Bench No.	Action	Picture
Supermarket	Supermarket area	7.4	Decentralize the supermarket by relocating the bins to be at the r benches as detailed in the benches details section.	
Tensile Test Equipment	Supermarket	7.5	Relocate the equipment to the new location (N6.4) as shown in Figure-2	
Cabinet	Supermarket	7.6	Decentralize the content of the cabinet to 2 small drawers to be placed underneath benches (TBD)	

Item Description	Production Line	Bench No.	Action	Picture
Tensile Test Equipment	Near Floor Management office	8.1	Relocate the equipment to the new location (N7.1) as shown in Figure-2	
Leakage Test Equipment	--		Locate this equipment at the end of row 2 (labeled as N2.6 in figure 2).	

## Needed Items for the Movement

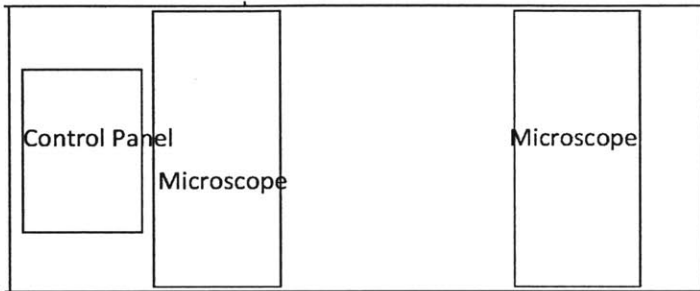
Table 9: Parts to be provided

Item Description	Quantity	Picture
Fume Cone to replace the hood on bench	1	
Drawers	4	
3 ft bench	1	
Bin Rail for 6 foot bench	3	

## New Layout Bench Details(selected page)

**Table 1, Bench N1.2 – E1**

Same bench, initially 3.2



### Equipment

Description	Asset Number	Old Bench	Voltage	Other Connections	New Bench
Microscope	123455	3.2	110V	N/A	N1.2
Microscope	122235	3.2	110V	N/A	N1.2
Control Panel	T53242	3.2	110V	Complex	N1.2

### Supermarket

Stock No.	Description	New Location	above the shelf / on bench
IM1084-03	Electronic Tungsten	N1.2	above
MC1246-01	Coil	N1.2	below