

# MEASUREMENTS AND CALIBRATION OF THE STRIPLINE BPM FOR THE ELI-NP FACILITY WITH THE STRETCHED WIRE METHOD

A. A. Nosych, U. Iriso, A. Olmos, A. Crisol, C. Colldelram, ALBA-CELLS, Barcelona, Spain  
 F. Cioeta, A. Falone, A. Ghigo, M. Serio, A. Stella, INFN/LNF, Frascati, Italy  
 A. Mostacci, Rome University, Rome, Italy

## Abstract

A methodology has been developed to perform electrical characterization of the stripline BPMs for the future Gamma Beam System of ELI Nuclear Physics facility in Romania. Several prototype units are extensively benchmarked and the results are presented in this paper. The BPM sensitivity function is determined using a uniquely designed motorized test bench with a stretched wire to measure the BPM response map. Here, the BPM feedthroughs are connected to Libera Brilliance electronics and the wire is fed by continuous wave signal, while the two software-controlled motors provide horizontal and vertical motion of the BPM around the wire. The electrical offset is obtained using S-parameter measurements with a Network Analyzer (via the ‘‘Lambertson’’ method) and is referenced to the mechanical offset.

## INTRODUCTION

The future Extreme Light Infrastructure Nuclear Physics (ELI-NP) facility will be located in Bucharest (Romania), and will be dedicated to the study of secondary light sources and attosecond pulses. This will be done by the Gamma Beam System (GBS) consisting of a 90 m long Linac producing a 700 MeV electron beam, whose main characteristics are listed in Table 1.

Table 1: Main Characteristics of the ELI-NP Linac

Number of bunches	32
Bunch spacing	16 ns
Charge/bunch	[25–400] pC
Bunch size, $\sigma_x$	100–200 $\mu\text{m}$
Bunch size, $\sigma_y$	100–200 $\mu\text{m}$
Bunch length, $\sigma_z$	3–4 ps

The stripline BPMs for the GBS of ELI-NP have been originally designed by the Accelerator division of INFN/LNF in Frascati (Rome), and are being manufactured by the company *Comeb*. After production, the BPM units are shipped to ALBA for electrical characterization and alignment measurements. In total there will be 32 BPM units, all of them  $\lambda/4$  stripline type working at  $\sim 500$  MHz, shorted on the downstream port. Figure 1 shows a schematic drawing and a model of the stripline, including the port naming convention used throughout all measurements.

This document describes the methodology followed to characterize the stripline BPMs. This is done in two ways: first, the so-called electrical offset is obtained ( $x_e, y_e$ ) using the well-known Lambertson method [1, 2], which is used to analyze the asymmetries among BPM electrodes.

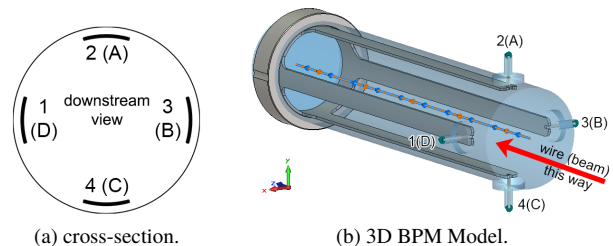

Figure 1: Naming convention and 3D BPM Model.

Next, we emulate the wire scan by scanning the BPM transversely around the stretched wire, Fig. 2, to obtain the sensitivity factors  $k_x, k_y$  and the mechanical offset ( $x_w, y_w$ ). These offsets, referenced with respect to BPM’s fiducial points, are due to all possible mechanical effects and they will be taken into account when installing the BPM units in the GBS Linac of ELI-NP facility.

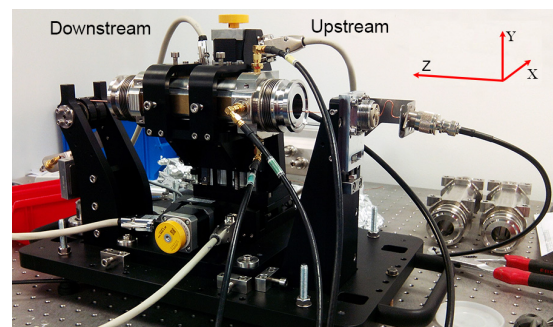

Figure 2: Photo of the BPM and the test bench in the lab.

## ELECTRICAL CHARACTERIZATION

The beam position ( $x_b, y_b$ ) in a symmetric BPM mounted in a circular chamber is obtained from the classical difference over sum (DOS) expression for the electrode signals  $V_{1..4}$  with removed offset:

$$x_b = k_x \times \frac{V_3 - V_1}{V_3 + V_1} - x_{\text{offset}} \quad (1)$$

$$y_b = k_y \times \frac{V_2 - V_4}{V_2 + V_4} - y_{\text{offset}} \quad (2)$$

### Lambertson Method

The BPM electrical center is defined as the position where  $V_3 - V_1 = V_2 - V_4 = 0$ , and it corresponds to the deviation ( $x_e, y_e$ ) from the BPM geometrical origin (mechanical center). Its measurement does not require a BPM precisely

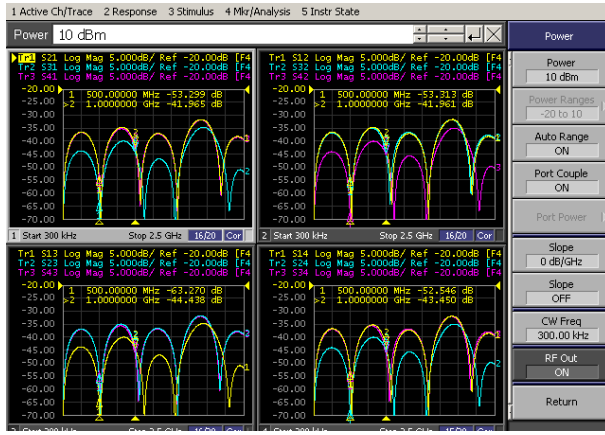

Figure 3: Sample snapshot of the S-parameter measurement by a Network Analyzer.

positioned on a test bench due to an external calibration method developed by D. Lambertson [1, 2].

This method uses the coupling between buttons/electrodes to determine the gain factors of each electrode; the ratios between gain factors then provide the difference between the mechanical and electrical centers. It has previously been applied to measure electrical offsets of the ALBA Booster BPMs with 6  $\mu\text{m}$  precision at fixed 500 MHz [3].

Each BPM electrode has an associated gain factor  $g$  which causes the difference between the mechanical and electrical center of a BPM. Based on differences between the gain factors we can obtain the electrical center with respect to the mechanical one:

$$x_e = k_x \times \frac{g_3 - g_1}{g_3 + g_1}, \quad y_e = k_y \times \frac{g_2 - g_4}{g_2 + g_4} \quad (3)$$

The normalized coupled voltage between two electrodes  $i$  (excited) and  $j$  (detected) is given by:

$$V_{ij} = 2 \cdot 50 \cdot G_{ij} g_i g_j. \quad (4)$$

where  $G_{ij} = G_{ji}$  are the capacitive coupling coefficients.

From the asymmetries between the electrodes, the gain factors  $g_{i,j}$  can be obtained from the three alternative combinations of the measured  $V_{ij}$ , e.g. for  $g_1$ , this is:

$$\begin{aligned} 2 \cdot 50 \cdot g_1^2 &= \frac{V_{21} V_{14}}{V_{42}} \times \frac{G_{13}}{G_{12} G_{23}} = \\ &= \frac{V_{12} V_{31}}{V_{32}} \times \frac{G_{23}}{G_{12} G_{13}} = \\ &= \frac{V_{41} V_{31}}{V_{43}} \times \frac{G_{12}}{G_{23} G_{13}} \end{aligned} \quad (5)$$

and 3 more similar triplet sets for  $g_{2,3,4}$ . Since we are interested in the ratios of gain factors (Eq. (3)), the values of  $G_{i,j}$  are not needed. Solving Eq. (5) and using Eq. (3) provides 3 different pairs of solutions ( $x_{e(a,b,c)}$ ,  $y_{e(a,b,c)}$ ) for each offset, whose good or bad agreement has to do with the quality of the geometrical symmetry of electrode strips.

In practice, the BPM electrical offset is obtained by measuring S-parameters of the 4 electrodes with a Network Analyzer (NA). In this case, we use the 4-port NA (*Agilent E5071B*, 300 kHz – 8.5 GHz). The NA output signal is injected through one electrode and the S-parameters of the other electrodes are measured, which correspond to the elements of the 4x4 scattering matrix (or S-matrix). A snapshot of one full measurement is shown in Fig. 3. Ideally the reflection coefficients should be zero and the transmission ones,  $S_{ij} = S_{ji}$ , symmetric.

The normalized voltage  $V_{ij}$  in Eq. (4) is equal to the transmission coefficient  $S_{ij}$ . The final calculation formula for the horizontal electrical offset, includes transformation from dB to linear S-parameter readings:

$$x_e = k_x \frac{\sqrt{10^{S_{x,ijm}/20}} - \sqrt{10^{S_{x,npq}/20}}}{\sqrt{10^{S_{x,ijm}/20}} + \sqrt{10^{S_{x,npq}/20}}} \quad (6)$$

and a similar one for  $y_e$ , where  $S_{xy,ijm}$  and  $S_{xy,npq}$  are combinations of S-parameter triplets originating from Eq. (5), which also depend on the solution of  $g_i$  used.

Finally, three variants of the offsets labeled (a), (b) and (c), e.g. ( $x_{e(a)}$ ,  $y_{e(a)}$ ) are using the corresponding sets of S-parameter triplets for  $x$  and  $y$ :

$$\begin{aligned} \text{(a)} \quad & \begin{cases} S_{x,ijm} = S_{32} + S_{42} - S_{43} \\ S_{x,npq} = S_{14} + S_{42} - S_{21} \end{cases} \\ \text{and} \quad & \begin{cases} S_{y,ijm} = S_{41} + S_{31} - S_{43} \\ S_{y,npq} = S_{32} + S_{31} - S_{21} \end{cases}, \end{aligned} \quad (7)$$

$$\begin{aligned} \text{(b)} \quad & \begin{cases} S_{x,ijm} = S_{43} + S_{42} - S_{32} \\ S_{x,npq} = S_{21} + S_{42} - S_{14} \end{cases} \\ \text{and} \quad & \begin{cases} S_{y,ijm} = S_{41} + S_{31} - S_{43} \\ S_{y,npq} = S_{32} + S_{31} - S_{21} \end{cases}, \end{aligned} \quad (8)$$

$$\begin{aligned} \text{(c)} \quad & \begin{cases} S_{x,ijm} = S_{43} + S_{14} - S_{31} \\ S_{x,npq} = S_{21} + S_{32} - S_{31} \end{cases} \\ \text{and} \quad & \begin{cases} S_{y,ijm} = S_{21} + S_{14} - S_{42} \\ S_{y,npq} = S_{32} + S_{43} - S_{42} \end{cases}. \end{aligned} \quad (9)$$

## Results

As an example, Fig. 4 shows the offset for a range of frequencies calculated by Eq. (6) for  $x_{e(a)}$ . Similar results are found for the vertical plane. The periodic notches are due to the electrode geometry and excitation system (excitation via one electrode, measuring on the others). This is in agreement with the CST simulations shown in Fig. 5, which compares the case in which the excitation is done via one electrode or through the wire. Note that when the excitation is done via one electrode (red), the notches occur at around 500 MHz, in agreement with Fig. 3. However, in the real case with an electron beam the notches are displaced to around 1 GHz.

Originally the ‘‘Lambertson’’ offset measurement is intended to be done at some fixed frequency; however, due

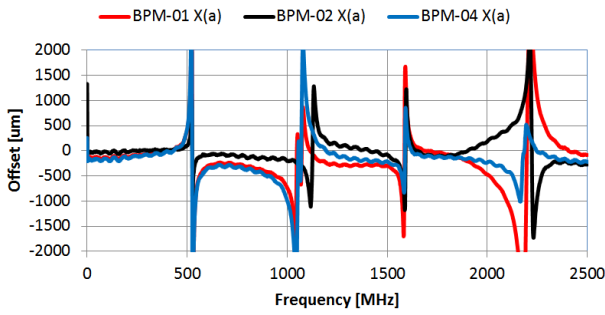

Figure 4: Horizontal electrical offset type  $x_{e(a)}$ .

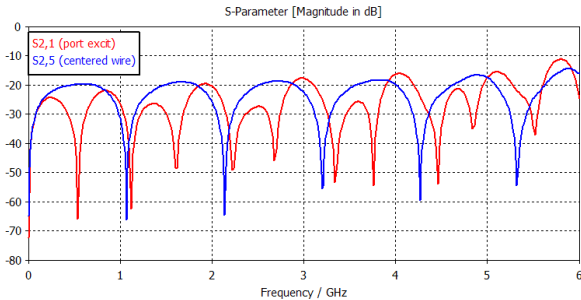

Figure 5: CST simulations exciting one electrode (red) or the wire (blue).

to aforementioned reasons, the measured offsets of the 3 striplines do not show a flat behavior at their working frequency, but rather a notch (see the zoom in Fig. 6). It therefore makes sense to take an average value for offsets in both planes between [20-200] MHz. This is shown in Table 2 for the three GBS BPMs measured so far. The electrical offsets are shown with margins taking into account the different S-parameter triplets (Eqs. (7), (8) and (9)).

The electrical offset measured this way is not affected by any systematic error due to the test bench or BPM positioning in space. However, this offset can not be compared directly with the one obtained by wire scans, because the mechanical offset measured by the wire scan is a combination of the offsets due to cable differences, reading electronics and geometrical imperfections of the BPM.

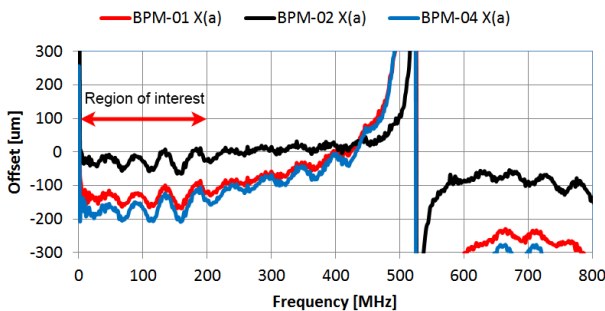

Figure 6: Horizontal electrical offset type  $x_{e(a)}$  (zoom).

Table 2: Electrical Offsets Measured Using the External “Lambertson” Method

	$x_e, \mu\text{m}$	$y_e, \mu\text{m}$
BPM-01	$132 \pm 0$	$-238 \pm 8.5$
BPM-02	$25 \pm 0.15$	$-134 \pm 10.4$
BPM-04	$165 \pm 0.7$	$-157 \pm 10$

### WIRE SCAN CHARACTERIZATION

The mechanical characterization is done via wire scanning the BPM units. The equipment and connectivity schematic is shown in Fig. 7. The BPM is placed on a test bench and a wire is pulled through its theoretical center using fiducials or other reference points/surfaces. The wire is fed by an RF signal generator and is terminated by 50 Ω at the other end. The signal, caught by the BPM electrodes, is read by *Libera Brilliance* electronics. The wire scan is done by moving the BPM in the horizontal and vertical directions using the motors in the test stand, controlled by a standard IcePap motor controller from a remote PC.

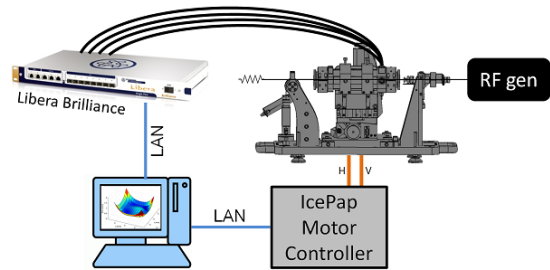

Figure 7: Schematic of lab setup and equipment connectivity for wire scanning the BPMs.

### Test Bench for Wire Mapping

The ALBA engineering department has designed an ad-hoc test bench to mechanically hold the stripline BPMs for stretched wire measurements. The bench is equipped with two motors (*Micos Linear Stage LS-120*) with unidirectional repeatability of 0.1 µm for horizontal and vertical movement. The test bench ensures reproducibility of within 20 µm between BPM-to-BPM measurements. Figure 8 shows a complete 3D model of a BPM mounted on the test bench; a photo of the setup is shown in Fig. 2.

As a compromise between stress and conductivity, the wire material is chosen to be copper of 1 mm in diameter. The wire tension is controlled by the force gauge at nominal force of 120 N to minimize contribution of the sag effect on measurements. For reference, the sag values in the mid-wire position for various tension, calculated by the catenary equation, are shown in Table 3.

Table 3: Sag Value in the Mid-Wire Position

Force, N	94	100	120
Deviation, µm	8.2	7.0	6.4

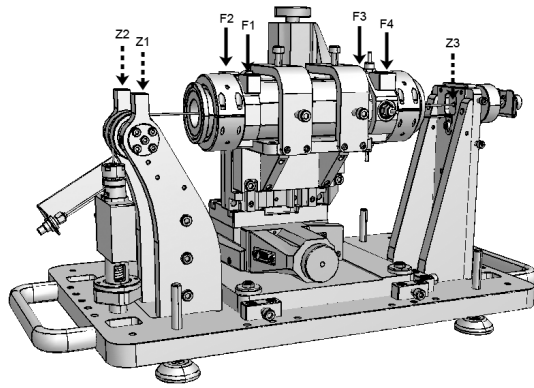

Figure 8: A complete 3D model of the test bench for ELI BPM measurements.

### Fiducial Measurements

Although the test bench ensures acceptable reproducibility of 20 μm, we have observed several mechanical issues that limit our precision to much larger values. Firstly, the BPM fiducials, labeled F1... F4 in Fig. 8 are often out of tolerances in both planes from the manufacturing criteria provided by factory certificates. As an example, Fig. 9 shows the deviations of fiducial planes as measured by the factory and by the ALBA alignment group for the vertical plane. While we generally measure slightly larger fiducial offsets, in some cases it reaches a 200 μm, and even 500 μm mismatch with respect to factory measurements.

Secondly, the diameters of some fiducial holes are out of tolerances, e.g. the 8 mm slot where the spherical mounted reflector (SMR) of the laser tracker is placed is sometimes larger by +100–200 μm (up to +400 μm in one case) with respect to +20 μm specified by the BPM drawings. This means that the horizontal position of the SMR alone can have a significant displacement.

Since its is not straightforward to align a BPM with respect to the wire by using BPM's fiducials, all BPMs are positioned on the test bench for wire mapping according to an established procedure:

- a) The stretched wire is considered as the nominal zero position, referenced by the three fiducials on the test bench (Z1, Z2 and Z3, as indicated by dashed arrows in Fig. 8).

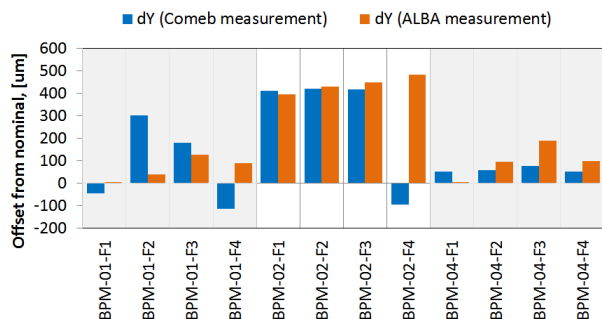

Figure 9: Fiducial position deviations from nominal in Y.

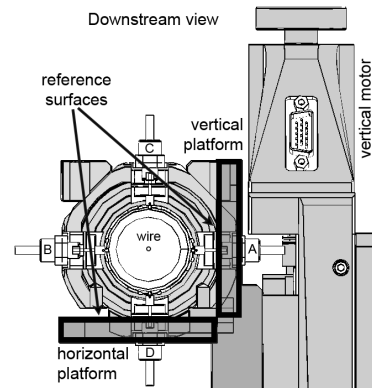

Figure 10: Positioning a BPM on an L-shaped platform by touching it with 2 reference surfaces.

- b) A BPM is placed on an L-shaped platform touching it with its two reference surfaces (bottom and right side walls), Fig. 10. The geometrical positions of the planes, manufactured with 20 μm precision, is known from the drawings with respect to BPM's origin. The pitch (20 μm in the horizontal plane) and yaw (10 μm in the vertical plane) errors of the platform are also measured.
- c) The L-platform, controlled by the motors, is placed such that its position with respect to the wire resembles the nominal distances from the BPM side walls to its center. This platform's position (motor settings) is defined as the *homing position*, meaning the wire here is at  $(x, y) = [0, 0]$  which is same for all BPMs.
- d) When the BPM is positioned on the platform its fiducial positions are measured with the laser tracker with respect to the stretched wire. Any tilt, yaw or roll imperfection of the particular BPM is encoded in its fiducial coordinates with respect to the stretched wire.
- e) After these considerations and measurements the BPM is mapped.

### Wire Mapping

Wire mapping is done by exciting the wire to a continuous wave excitation of 499.654 MHz and moving the motors to scan the BPM around the wire. The motor positions are then translated into wire movements. The electrode voltages are read by the Libera with averaging over 1024 samples and processed by DOS equations with  $k_x = k_y = 10$ :

$$x_{bpm} = k_x \times \frac{V_3 - V_1}{V_3 + V_1} \tag{10}$$

$$y_{bpm} = k_y \times \frac{V_2 - V_4}{V_2 + V_4} \tag{11}$$

Figure 11 shows the result of wire scanning of one of the first BPM units, including the error map defined as absolute distance between the measured and actual wire positions. The measured map offset  $(x_w, y_w)$  is relative to the wire at its homing position. It includes the mechanical and the "Lambertson" electrical offsets, hence  $x_{offset} = x_w$  and  $y_{offset} = y_w$ .

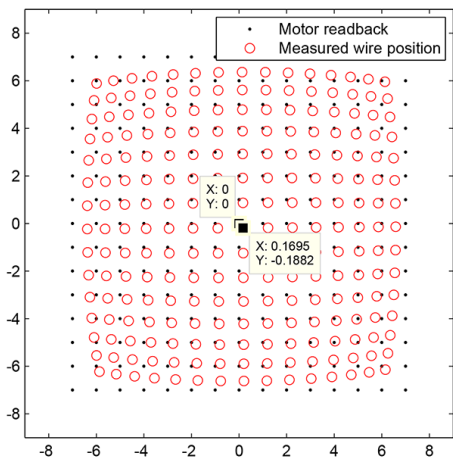

(a) BPM response map measured by wire scanning within  $\pm 7$  mm. The central point corresponds to the wire homing position (0, 0). Its electrode readings correspond to the mechanical offset of the BPM.

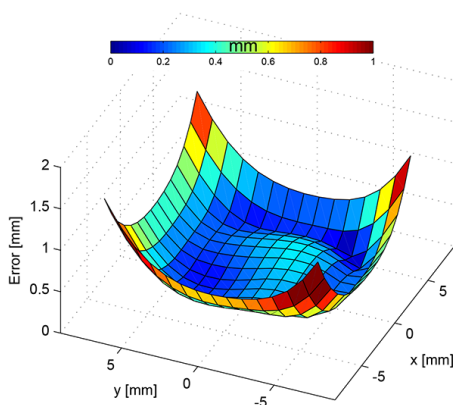

(b) Error of the response map in mm with respect to motor read-back positions.

Figure 11: Wire mapping the BPM-02 of the ELI-NP.

The repeatability of wire scans was also checked by measuring the map center with respect to the homing position by repeating the dismount-mount cycle of same BPM several times. This way the map center was usually measured within  $50 \mu\text{m}$  in both X and Y for all BPMs.

**Results**

Table 4 lists the results of the offsets measured by wire scanning. These values include both the electrical offsets, shown in Tab 2, and mechanical manufacturing imperfections. Besides, while the theoretical value of  $k_{x,y} = 10$ , its

Table 4: Offsets Measured Using the Wire Scan

	$k_x$	$k_y$	$x_w, \mu\text{m}$	$y_w, \mu\text{m}$
BPM-01	9.57	9.51	$146 \pm 39$	$-19 \pm 16$
BPM-02	9.47	9.45	$114 \pm 14$	$-210 \pm 48$
BPM-04	9.57	9.54	$256 \pm 16$	$-139 \pm 34$

values, measured in  $3 \times 3$  points within  $\pm 1$  mm, are also shown.

**CONCLUSIONS**

Using different techniques, we have measured the electrical and the mechanical offsets of several BPM units for the future Gamma Beam System of the ELI Nuclear Physics facility.

For the electrical offset an external calibration, called the ‘‘Lambertson’’ method, was applied, estimating the geometrical asymmetry of the stripline electrodes. For measuring the mechanical offset and the sensitivity factors of the BPMs we have designed and built a motorized test bench for wire mapping the BPM units. The obtained sensitivity factors have shown to be smaller than their theoretical value. Fiducial coordinates of the BPM units were also measured with the laser tracker and found to be significantly different from the factory-provided values.

The mechanical offsets, referenced with respect to BPM’s fiducial points, are due to all possible mechanical effects and they will be taken into account when installing the BPM units in the GBS Linac of ELI-NP facility.

**ACKNOWLEDGEMENTS**

We would like to thank the alignment team of ALBA, M. Llonch and J. Landera for their time and extensive alignment measurements.

**REFERENCES**

- [1] G.R. Lambertson, ‘‘Calibration of Position Electrodes using external measurements’’, LSAP Note-5, LBL, 1987.
- [2] Y. Chung, G. Decker, ‘‘Offset calibration of the Beam Position Monitor Using External Means’’, Proc. of 1991 Acc. Instrum. Workshop.
- [3] A. Olmos, M. Alvarez and F. Perez, ‘‘Beam position monitors characterization for ALBA’’, TUPSM075, Proceedings of BIW10, 2010.