

# The Influence of runner system on production of injection molds

Vaclav Janostik<sup>1,a</sup>, Michal Stanek<sup>1</sup>, David Manas<sup>1</sup>, Miroslav Manas<sup>1</sup> and Vojtech Senkerik<sup>1</sup>

<sup>1</sup> Tomas Bata University in Zlin, TGM 5555, 760 01 Zlin, Czech Republic

**Abstract.** This experimental study describes the influence of runner system on rheological properties during the injection molding process. Economic effects on the amount of production are discussed as well. Autodesk Moldflow Synergy 2016 (Moldflow) was used for the study of the injection process. Three suggestions of the runner system, cold runner system, hot runner system and the combination of cold-hot runner system have been promoted. These three variants underwent the rheological and economic analysis. As a result, recommendations for the application of the runner system for the required amount of production have been suggested

## 1 Introduction

Injection molding is a thermodynamic cyclic process forming of polymer materials wherein material from a solid phase in a granular form is transferred into plastic state (a state of melt) under the action of thermal and mechanic (dissipative) energy. Afterwards the material in a plastic state is injected at a high speed in a closed cavity of a mould which is tempered for injecting of thermoplastic at a significantly lower temperature than the temperature of the melt.

The price of an injected part plays an important role. The price depends on the amount of the production, difficulty of injection mold, multiplicity of injection mold and the quantity of the used material. The aim of this experiment to determine the suitability of a runner system based on the amount of the production for the specific part.

The technology of injection is used for the production from hundreds to millions products. Any particular saving on the time or quantity of the used material causes an important financial saving.

## 2 Process setting

Experiments were processed in a moldflow program. Very similar injecting conditions were set for all the types of experiments. Product was projected in 3D mesh. The vertices were 1,5 mm distant. Trajectory tempering circuits were the same as well. Diameter of a tempering channel was 6 mm. Tempering medium was the solution of ethylene glycol and water in the ratio of 1:4. Material of the product was selected from MID - Range polymers PA66 filled with 30% of glass fiber by Ultramid A3EG6. The weight of one piece of the product is 21g. Total weight is 84g because the conception is quadrupled. The rest is waste.

**Table 1.** Process parameters.

Process parameter	CRS	HRS	HRSCG
Filling time [s]	2	1,3	1,4
Pressure controlled [%]	90	90	90
Melt temperature [°C]	300	300	300
Ejection temperature [°C]	195	195	195
Max pressure [MPa]	15	18,87	34,2
Cooling [s]	30	30	30

## 3 Experiment

### 3.1. Cold runner system (CRS)

The first variant was a cold runner system which is one of the most simple from the construction point of view. No necessary special construction parts or components forming the runner system are needed. This advantage is very important for the price of the injection mold.

Inlet system is formed by runner insert which guarantees leakage of injection mold with a plasticizing unit of the injection molding machine. Furthermore, the anchoring plates milled inlet channels. The aim of this channel is to distribute polymer melt into shaped mold cavities. The last section of the runner system is a gate locatio, which can influent the shear rate for filling the cavity. Determination of suitable place can minimize pressures required for the transport of the polymer melt.

The final price consists of the price of injecting mold, quantity of material consumption for the production and consumption of energy. In this case, the option with the cold runner system means a consumption of material of 120 g for one cycle. Total weight of a product is 84 g.

<sup>a</sup> Corresponding author: [vjanostik@ft.utb.cz](mailto:vjanostik@ft.utb.cz)

The big part of this number is waste. It is 36 g which is 30% of total weight of material used.

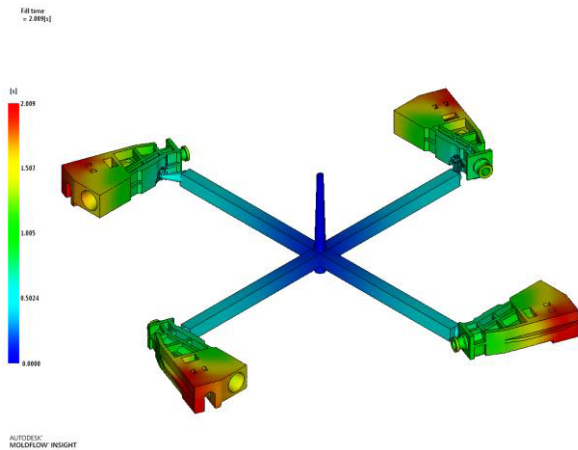

Figure 1. Cold runner system.

### 3.2. Hot runner system (HRS)

The second option for the analysis is the injection mold with a hot runner system. This conception is much more complex if compared with a cold distribution system. There is a need of additional plates of the injecting mold, such as spacers. Furthermore, special constructions parts of inlet system, which are usually heat resistant, are used. These constructions parts are very expensive and therefore it increases the final price of machine. Design of part placement in mold is similar to the first variant. The cold runner system is substituted by hot distribution system consisting of a hot distribution block and four hot nozzles. The significant advantage of this option is no waste.

The weight of material needed for fulfilling one cycle is 84 g. Due to using the special construction parts, this injection form is 4 800 € more expensive than within the cold runner system.

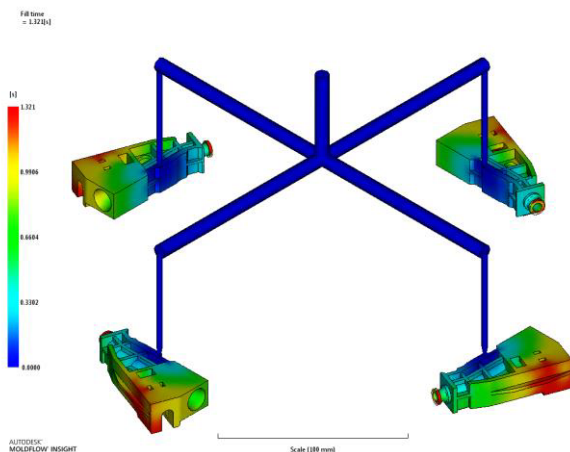

Figure 2. Hot runner system.

### 3.3. Combination of a hot runner system and a cold gate location (HRSCG)

The third variant is the combination of a hot runner system and a cold gate zone. This variant combines the advantages of a hot runner system and cold gate zone. There is also a benefit of using a cold gate zone as it is a low price part of a relatively simple construction. Inlet system is formed by hot distribution system, two nozzles and a gate zone which is milled on the anchor plate. Compared to Experiment 1, this is also an expensive design but still cheaper than Experiment 2 with a hot distribution system. A runner block of type 1 and only two nozzles perform in this option.

Total weight of a product is 84 g and the number of waste is minimized to 6%, only. From the economic point of view, the amount of waste is acceptable. The final price is about 2 500 € higher than in Experiment 1.

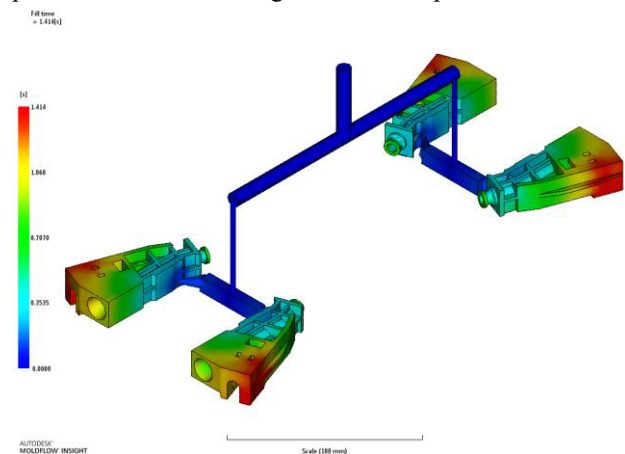

Figure 3. Combination Hot.

## 4 Results

### 4.1. Economic results

The options described above have been compared from the economic point of view. The most important factor is the amount of production. The price and consumption of the material and energy required for the heating of elements are included as well.

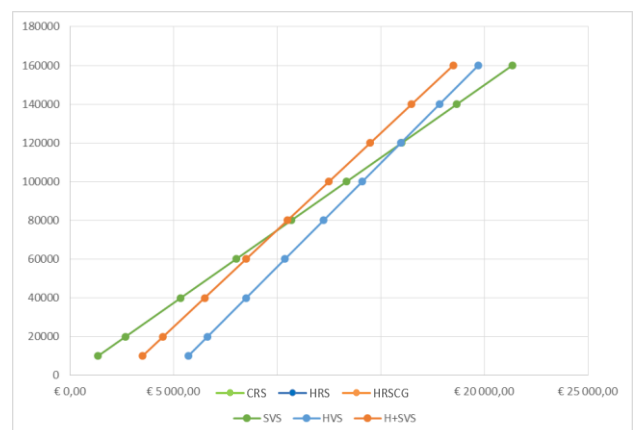

Figure 4. Economic index.

For the number of products up to 80 000, the option described in Experiment 1 should be performed, although the amount of waste represents 36%. It could be decreased by using the variant with a combined system where the waste is only 6%. But the financial savings due to the lower consumption of the material are not so significant.

Within the production over 80 000 pieces it is profitable to use the option with a combined runner system. There is a smaller amount of waste and special construction parts of a runner system and materials would be saved as well. There are lower costs associated with recycling the waste.

Regarding the production over 350 000 pieces savings precautions could be performed by using an injecting mold with a hot runner system.

## 4.2 Technical results

### 4.2.1 Pressure at injection

The following figure shows the progress of the pressure during the injection cycle. The injection cycle was optimized to provide an optimal progress of the pressure in the mold cavity. At the beginning there is a steep increase of pressure during the filling phase. The value of the highest pressure is called an injection pressure. Followed by a slight decrease during a replenishment of the melt, it leads to the compression of the melt inside the mold cavity. Then the sharp decrease of pressure occurs due to freezing inlet orifice. It is followed by a cooling phase and by fixing the product in the final shape. After that, the mold is opened and the moldings are ejected.

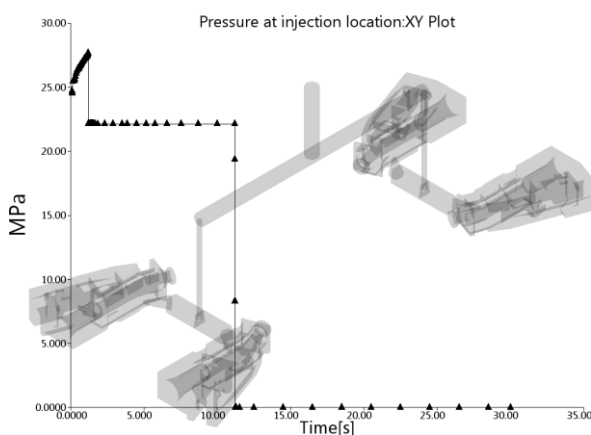

Figure 5. Pressure at an injection location.

### 4.2.2 Clamp force

The following graph describes the process of clamping force in injection cycle. When the mold is in the injection phase and the injection pressure counteract to the closing force, the closing force have to be the biggest. The melt tends to open the form and against the acting closing force. The value of the maximum closing force of the

machine is 2 000 kN. The closing force required at the time of injection is only 190 kN. There is a lot of space for clamping force.

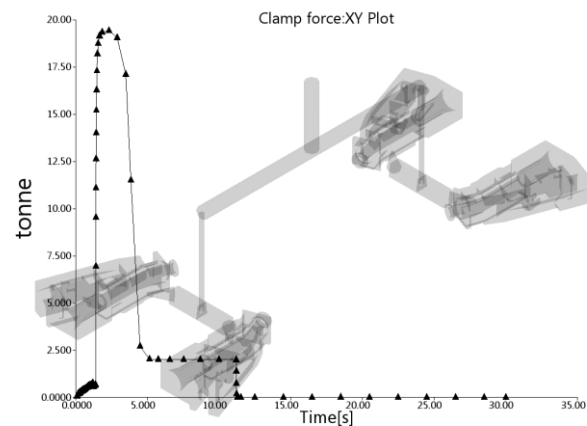

Figure 6. Clamp Force.

### 4.2.3 Deformation

The level of deformation is characterized by the difference in dimensions of forms and dimensions of the resulting moldings. The shrinkage value is influenced by both the type of polymer, the shape of the ejection and by the injection mold (gating, holding pressure and choice of tempering channels). The total deformation of operating pressures, material shrinkage and the influence of annealing is 0.5 mm. This value is relative to the central axis of a system model. To achieve preservation of dimensions of the products the mold cavity should be increased by a shrinkage value.

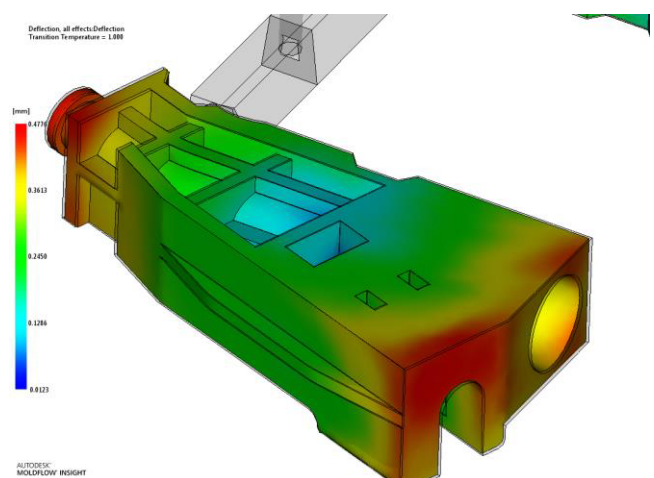

Figure 7. Absolute deformation.

### 4.2.4 Weld lines

The cold seal is formed by a collision of the front of the melt, such as wrapping cores. It is caused by local lower

strength product. The following figure shows the placement of the collision of two faces melt and the formation of the cold joints. The most serious are the furthest cold joints. Due to long flow paths the fronts of the cooled polymer melt is cooled at this point and metallic additional coating is located there as well. The temperature of the polymer melt front at this point is 298°C. Due to such a high temperature of the polymer melt a cold seal with a significantly lower strength is not created.

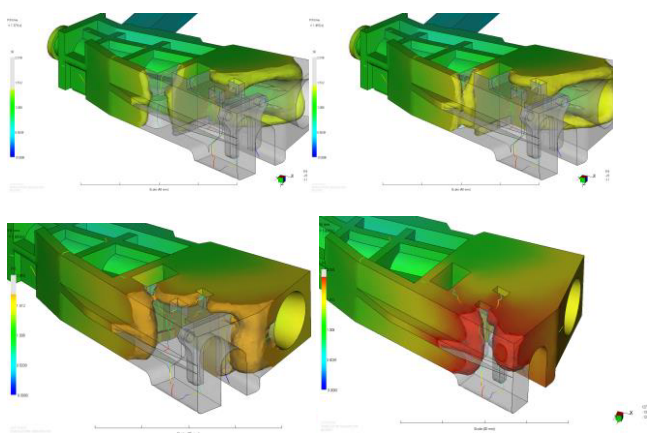

Figure 8. Weld lines.

Table 2. Results.

Result	CRS	HRS	H+SVS
Fill time [s]	2	1,3	1,4
Max Pressure [MPa]	14,88	18,87	34,52
Clamp force [tonne]	13,70	12,26	24,30
Max share rate [1/s]	18 916	11 369	21 349
Shear stress at wall [MPa]	0,22	0,19	0,24
Circuit flow rate[lit/min]	1,4	1,4	1,4
Warp deflection [mm]	0,51	0,39	0,47

## 5 Conclusion

Because of the similar design aspects, such as the location of the inlet orifice, choice of the temperature and technological conditions, technological results are similar.

Time of filling is the same for all analysed options and ranged between 2 and 1.3 s. The highest pressure inside the intake system is the variant with a combination of a hot distribution channel with the cold-air intake opening. This phenomenon has occurred because of the great complexity of the flow paths. With the size of the pressure inside the cavity the size of the closing force is related. It is the opposite of the force of the pressure and prevents the injection mold from opening. The largest

speed shear deformation is also the variant of HRSCG. This value is not approaching the limit value of the rate of shear deformation which is satisfactory. From the economic point of view it is best to use the option of HRSCG. It suits all the technological parameters and economic requirements. The amount of the production is a significant value. With the knowledge of this information, the injection mold could be designed to perform significant financial and time savings.

## Acknowledgement

This work was supported by the Ministry of Education, Youth and Sports of the Czech Republic within the National Sustainability Programme project No. LO1303 (MSMT-7778/2014) and by the European Regional Development Fund under the project CEBIA-Tech No. CZ.1.05/2.1.00/03.0089 and also by the internal grant of TBU in Zlin No. IGA/FT/2016/010 funded from the resources of specific university research.

## References

1. M. Ovsik, D. Manas, M. Manas, M. Stanek, M. Hribova, K. Kocman, D. Samek, Irradiated Polypropylene Studied by Microhardness and WAXS, *Chemicke listy* 106, (2012)
2. M. Stanek, M. Manas, D. Manas, V. Pata, S. Sanda, V. Senkerik, A. Skrobak, How the Filler Influence the Fluidity of Polymer, *Chemicke listy*, (2011)
3. M. Stanek, D. Manas, M. Manas, O. Suba, Optimization of injection molding process, *Intl. J. of Math. and Computers in Simul.*, Vol.5, No.5, (2011)
4. J. Javorik, M. Stanek, The shape optimization of the pneumatic valve diaphragms, *Intl. J. of Math. and Computers in Simul.*, Vol.5, No.4, (2011)
5. M. Stanek, D. Manas, M. Manas, J. Javorik, Simulation of injection molding process by cadmould rubber, *Intl. J. of Math. and Computers in Simul.*, Vol.5, No.5, (2011)
6. M. Ovsik, D. Manas, M. Manas, M. Stanek, M. Bednarik, P. Kratky, Effect of beta irradiation on microhardness of polyamide 6, *Key Engineering Materials*, vol. 586, (2014)
7. M. Manas, D. Manas, M. Stanek, A. Mizera, M. Ovsik, Modification of polymer properties by irradiation properties of thermoplastic elastomer after radiation cross-linking, *Asian Journal of Chemistry*, vol. 25, Issue 9, (2013)
8. Tim A. Osswald, *International Plastics Handbook: the Resource for Plastics Engineers* (fourth ed.) Hanser Publishers, Munich (2006)
9. Dobransky, J., et al. Comparison of Cooling Variants by Simulation Software. *Advanced Materials Research*. Vol. 801 (2013). pp. 75-80. ISSN 1022-6680.
10. Behalek, L. and Dobransky, J. Conformal cooling of the injection moulds. *Applied Mechanics and Materials*. Vol. 308 (2013). pp. 127-132. ISSN 1660-9336.