

Technical University of Denmark



2D Numerical Modelling of the Resin Injection Pultrusion Process Including Experimental Resin Kinetics and Temperature Validation

Rasmussen, Filip Salling; Sonne, Mads Rostgaard; Larsen, Martin ; Spangenberg, Jon; Lilleheden, Lars T.; Hattel, Jesper Henri

Published in:

Proceedings of the 21s International Conference on Composite Materials (ICCM-21)

Publication date:

2017

Document Version

Peer reviewed version

[Link back to DTU Orbit](#)

Citation (APA):

Rasmussen, F. S., Sonne, M. R., Larsen, M., Spangenberg, J., Lilleheden, L. T., & Hattel, J. H. (2017). 2D Numerical Modelling of the Resin Injection Pultrusion Process Including Experimental Resin Kinetics and Temperature Validation. In Proceedings of the 21s International Conference on Composite Materials (ICCM-21)

DTU Library

Technical Information Center of Denmark

General rights

Copyright and moral rights for the publications made accessible in the public portal are retained by the authors and/or other copyright owners and it is a condition of accessing publications that users recognise and abide by the legal requirements associated with these rights.

- Users may download and print one copy of any publication from the public portal for the purpose of private study or research.
- You may not further distribute the material or use it for any profit-making activity or commercial gain
- You may freely distribute the URL identifying the publication in the public portal

If you believe that this document breaches copyright please contact us providing details, and we will remove access to the work immediately and investigate your claim.

2D NUMERICAL MODELLING OF THE RESIN INJECTION PULTRUSION PROCESS INCLUDING EXPERIMENTAL RESIN KINETICS AND TEMPERATURE VALIDATION

*Filip S. Rasmussen¹, Mads R. Sonne¹, Martin Larsen², Jon Spangenberg¹, Lars T. Lilleheden² and
Jesper H. Hattel¹.

¹ Produktionstorvet Building 425, DK-2800 Kgs. Lyngby, Department of Mechanical Engineering,
Technical University of Denmark.

² Barmstedt Allé 5, DK-5500 Middelfart, Fiberline Composites A/S

* Corresponding author: fsras@mek.dtu.dk

Keywords: Composites, Pultrusion, Curing, Modelling, Characterization.

ABSTRACT

In the present study, a two-dimensional (2D) transient Eulerian thermo-chemical analysis of a carbon fibre epoxy thermosetting Resin Injection Pultrusion (RIP) process is carried out. The numerical model is implemented using the well known unconditionally stable Alternating Direction Implicit (ADI) scheme. The total heat of reaction and the cure kinetics of the epoxy thermosetting are determined using Differential Scanning Calorimetry (DSC). A very good agreement is observed between the fitted cure kinetic model and the experimental measurements. The numerical steady state temperature predictions inside the composite profile are validated by comparison with experimental measurements and good agreement is found.

1 INTRODUCTION

The resin injection pultrusion (RIP) process is a continuous, automated, closed moulding and cost effective composite manufacturing process used for high-volume production of constant cross sectional composite parts. The fiber reinforcements are first fed through pre-forming guiders which start shaping the reinforcements into the finished product. These reinforcements are then pulled into a resin injection chamber being wetted out and subsequently entering a heating/forming die where the exothermic reaction is initiated and consequently curing the resin. The cured profile is advanced via a pulling system to a cut-off saw where it is cut to its final length. A schematic representation of the RIP process is illustrated in Fig. 1.

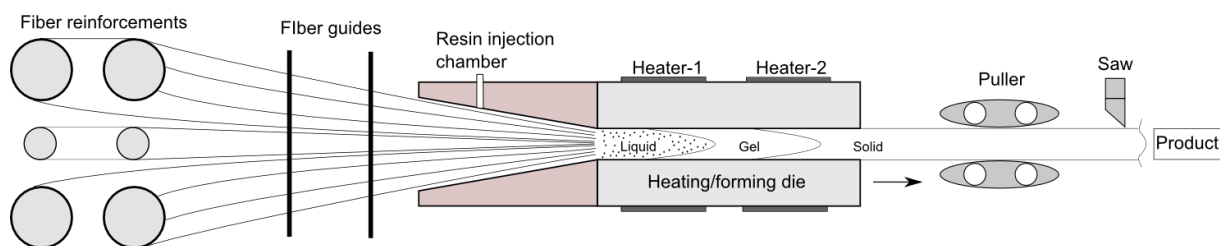

Figure 1: Schematic representation of the Resin Injection Pultrusion (RIP) process.

Several numerical studies of pultrusion are found in literature, e.g. investigating temperature and degree of cure development inside the die. The well known finite difference method (FDM), finite volume method (FVM) or finite element method (FEM) have been utilized.

A thermo-chemical model of the pultrusion process using thermosetting resins was used in [1]. In this study, longitudinal heat transfer was neglected. Hence, a simplified one dimensional (1D) model utilizing the FDM was carried out implicitly. In [2,3], two dimensional analyses were carried out using the Alternate Direction Implicit (ADI) scheme, which is known to be unconditionally stable [4]. In both studies [2,3], the effects of chemical cure shrinkage on the interface heat transfer between die and profile is accounted for by thermal contact resistances.

Three dimensional (3D) simulations on different composite cross section profiles were conducted in [5-7]. In [5], the unconditionally stable ADI Douglas-Gunn (ADI-DG) scheme was implemented for the first time in this field of application. The exothermic curing kinetics of thermosetting resins are in general characterized using Differential Scanning Calorimetry (DSC) [8].

In the present study, a 2D thermo-chemical analysis of the RIP process of a flat composite plate is performed using a transient approach. The unconditionally stable 2D ADI scheme is used for the implementation based on [5,9,10]. The cure kinetics of the resin, hence, exothermic heat generation is characterized using DSC. A detailed description is given regarding discretization of the convective/advective terms (spatial derivatives) as well as the time stepping. The steady state temperature predictions are validated by comparison with temperature measurements inside the profile. The analyses are performed on an industrial carbon fibre/epoxy based pultrusion profile.

2 GOVERNING EQUATIONS

Considering pultrusion of thin plates (*width* \gg *thickness*) an assumption of negligible heat transfer in the width direction is assumed to prevail. Hence, the heat transfer phenomenon in a thin plate pultrusion case will be governed by the 2D transient energy equation, see (1). From (1) it should be noticed how the convective nature of the pultrusion process is only considered along the pulling direction x (axial or longitudinal), see Fig. 5.

$$\rho C_p \left(\frac{\partial T}{\partial t} + u \frac{\partial T}{\partial x} \right) = \frac{\partial}{\partial x} \left(k_x \frac{\partial T}{\partial x} \right) + \frac{\partial}{\partial z} \left(k_z \frac{\partial T}{\partial z} \right) + \dot{Q}''' \quad (1)$$

where T is temperature, t is time, u is pulling speed (x -direction), ρ is density, C_p the specific heat, k_x and k_z are the thermal conductivities in the x - and z -directions, respectively and \dot{Q}''' is the source term. Equation (1) is directly applicable for the heat transfer analysis of the composite profile, while when considering the die, the convective term and the source term are discarded.

Pultrusion of thermosetting based composites implies exothermic heat generation associated with the curing process. The exothermic heat generation is included in the energy equation via the following source term:

$$\dot{Q}''' = (1 - V_f) \rho_r Q \quad (2)$$

where V_f is the fibre volume fraction, ρ_r the resin density and Q the specific heat generation rate [W/kg] associated with the exothermic curing reaction of the resin.

The degree of cure (α) can be expressed as the ratio of the amount of heat generated to the total heat of reaction, i.e. $\alpha = H(t)/H_{tr}$. Hence, the cure rate or reaction of cure (R_r) is given by:

$$R_r = \frac{d\alpha}{dt} = \frac{1}{H_{tr}} \frac{dH(t)}{dt} \quad (3)$$

Realizing that $Q = dH(t)/dt$ and combining (2) and (3) gives:

$$\dot{Q}''' = (1 - V_f) \rho_r H_{tr} R_r \quad (4)$$

where H_{tr} is the total heat of reaction and the reaction of cure is described using an Arrhenius type temperature dependency and an autocatalytic reaction mechanism model [11,12]:

$$R_r(\alpha, T) = A \cdot \exp \left\{ \frac{-E}{R \cdot T} \right\} \cdot \alpha^m (1 - \alpha)^n \quad (5)$$

The kinetic parameters (A, E, m, n) are obtained by regression analysis on DSC data.

Due to the advective/convective nature of the pultrusion process (the degree of cure is a function of both time and position, $\alpha(t, x)$) care must be taken when evaluating the cure rate. This is accounted for by taking the total derivative of the degree of cure using the chain rule

$$\frac{d\alpha}{dt} = \frac{\partial\alpha}{\partial t} \frac{dt}{dt} + \frac{\partial\alpha}{\partial x} \frac{dx}{dt} = \frac{\partial\alpha}{\partial t} + u \frac{\partial\alpha}{\partial x} \quad (6)$$

and by combining (3) and (6) the following is obtained:

$$\frac{\partial\alpha}{\partial t} = R_r(\alpha, T) - u \frac{\partial\alpha}{\partial x} \quad (7)$$

3 NUMERICAL IMPLEMENTATION

The 2D domain is discretized using the control volume based finite difference method (CV-FDM) where two adjacent control volumes are coupled via the sum of thermal resistances between them (coupled in series) [9]. Fig. 2 illustrates the spatial discretization using a structured mesh, the resistances and the indexing using subscripts.

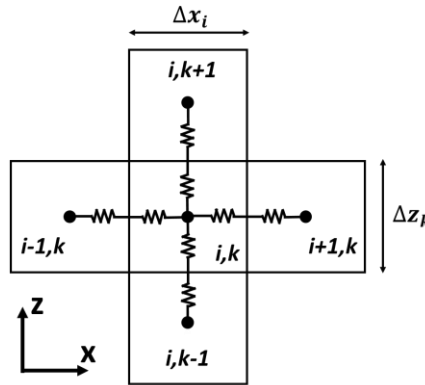

Figure 2: Schematic representation of indexing in the 2D domain (length-thickness plane) including thermal resistances (zigzag lines).

An upwind scheme is used for the discretization of the convective term and the spatial discretization of the degree of cure (advective term). This is necessary in order to obtain stable numerical solutions for high Peclet numbers, i.e. $Pe > 2$, [5,10]. The dimensionless Peclet number is defined as:

$$Pe = \frac{u \cdot \Delta x}{\kappa} \quad (8)$$

where $\kappa = k/\rho c_p$ is the thermal diffusivity. The Peclet number indicates the strength between convection and conduction.

The exothermic heat generation (4) and the resin kinetics (5) are coupled with the energy equation (1) in an explicit manner to ensure a fast numerical solution as suggested in [5]. The degree of cure is updated explicitly using the upwind discretised form of (7):

$$\frac{\alpha_{i,k}^{t+\Delta t} - \alpha_{i,k}^t}{\Delta t} = [R_r(\alpha, T)]^t - u \frac{\alpha_{i,k}^t - \alpha_{i-1,k}^t}{\Delta x} \quad (9)$$

where Δx is evaluated equally between the two adjacent control volumes (i, k) and $(i-1, k)$.

The convergence criteria for reaching steady state are defined as a maximum change in temperature and degree of cure of $1e-4^\circ\text{C}$ and $1e-6$, respectively.

4 MATERIALS CHARACTERIZATION – EPOXY RESIN CURE KINETICS

DSC experiments are carried out in order to characterize the curing kinetics of an industrial thermosetting epoxy resin. The cure kinetics parameters are used in the resin reaction model for the numerical simulations, see (5). The experiments were carried out using three isothermal (120, 130, 140 °C) and three dynamic (5, 7.5, 10 °C/min) temperature programs in order to obtain a versatile Cure Kinetic Model (CKM) describing a wide range of processing conditions [13-15]. A sample mass of 9mg and a sampling rate of $1s^{-1}$ were used for all the experiments. For all 6 type of experiments, three to five samples were tested. The mean heat flow curve for each type of experiment is depicted in Fig. 3.

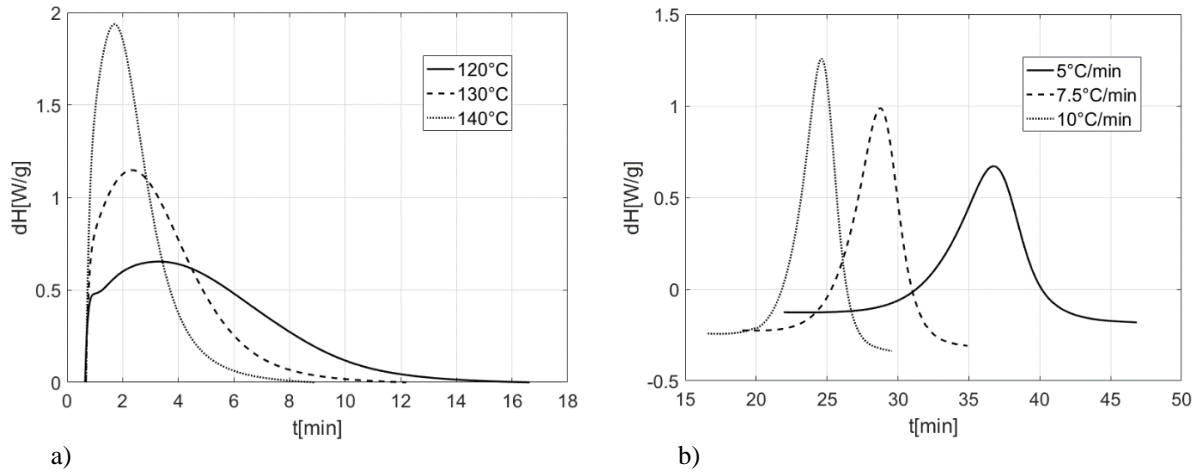

Figure 3: Heat flow curves from DSC experiments. a) Isothermal, b) dynamic.

All the heat flow curves (cf. Fig. 3) show a clear exothermic peak. A mean total exothermic heat of reaction of $H_{tr} = 282 \pm 12 \frac{kJ}{kg}$ is calculated by integration of the heat flow curves using a linear baseline. The cure rate and the degree of cure is then calculated using (3).

A least square non-linear regression analysis is used to estimate the kinetic parameters for the CKM (cf. Eq. (5)). The least squares non-linear regression analysis evaluates and minimizes the residual sum of squares (RSS) [15]. In the present work the regression is conducted using the *fminsearch* built-in function in *Matlab* for minimizing the following RSS:

$$RSS = \sum_{j=1}^6 \sum_{i=t_s}^{t_e} \left\{ \left[\frac{d\alpha}{dt} \right]_{i,j}^{measured} - \left[A \cdot \exp \left\{ \frac{-E}{R \cdot T_{i,j}} \right\} \cdot \alpha_{i,j}^m (1 - \alpha_{i,j})^n \right]^{CKM} \right\}^2 \rightarrow 0 \quad (9)$$

where i and j indicate all the data points and each of the 6 experiments, isothermal: (120, 130, 140 °C) and dynamic: (5, 7.5, 10 °C/min), respectively. The fitted cure kinetic parameters are summarized in Table 1.

The experimental cure rate is compared with the corresponding predictions obtained using the fitted CKM, see Fig. 4.

Kinetic parameters	Units	Fitted value
A	$[s^{-1}]$	6125e3
E	$[J/mol]$	67857
m	–	0.45
n	–	1.03

Table 1: Fitted cure kinetic parameters for the thermosetting epoxy resin.

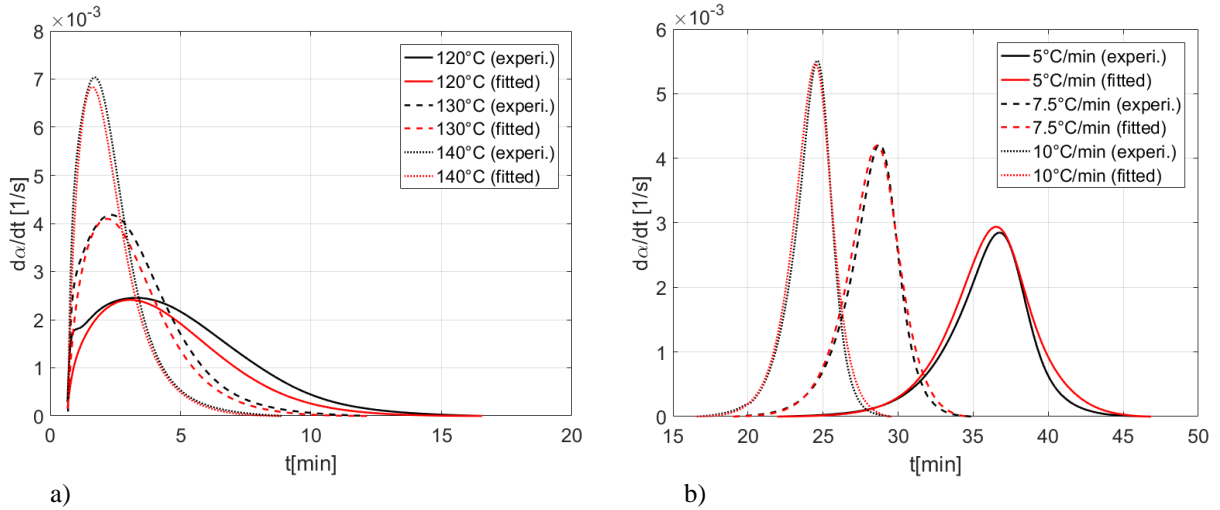

Figure 4: Comparison of experimental cure rate with CKM predictions (cf. Eq. (5) and Table 1).
a) isothermal, b) dynamic.

Comparing the experimentally estimated cure rates with the corresponding CKM predictions a very good agreement is generally observed (cf. Fig. 4). It should, however, be noticed how the CKM predictions for the isothermal cure rate curves (Fig. 4a) are in general a little too narrow, while the opposite is true for the dynamic cure rate curves (Fig. 4b). These deviations are considered to be a result of including all 6 experimental data sets in the same regression analysis. The fitted CKM is, however, also considered the most versatile, hence an applicable model for numerical implementation.

5 VALIDATION TEST CASE

In the present study, a unidirectional (UD) carbon fibre/epoxy based laminate is investigated both experimentally and numerically. The work is bound by a non-disclosure agreement with *Fiberline Composites A/S (Middelfart, Denmark)*. Hence, most dimensions, process conditions and material data and results are presented in normalized form. The material properties of the steel die and the constituent and effective laminate are summarized in Table 2. The laminate geometry is a thin plate, hence the $width \gg thickness$. Because of the relatively small thickness the heat transfer in the width direction is assumed negligible, effectively leaving the two directions of interest the thickness- and length-directions. Hence, a simple, symmetrical 2D domain is considered sufficient for the numerical analysis. The analyzed domain is the heating/forming die (cf. Fig 1). A setup with three heaters and a single cooler with the following normalized temperatures are used, heaters: (103, 102, 85), cooler: 25, see Fig. 5.

Initially all nodal point temperatures are set to normalized ambient conditions ($T = 11$) and the degree of cure in all composite nodal points are set to a negligible value ($\alpha = 1e-30$). For $t > 0$ a normalized infusion temperature of 28 is used at the die inlet while an adiabatic boundary is used at the

die exit. The ambient convective cooling of the die is implemented in the numerical model via a heat transfer coefficient of $HTC = 15 \frac{W}{m^2K}$, which is considered applicable for natural convection [16].

Material:	$\rho \left[\frac{kg}{m^3} \right]$	$C_p \left[\frac{J}{kgK} \right]$	$k_x \left[\frac{W}{mK} \right]$	$k_z \left[\frac{W}{mK} \right]$
Epoxy	1255	1201	0.189	0.189
Carbon fibre	1825	710	200	80
Lumped (ROM, $V_f = 60-67\%$)	1630	878	132	0.55
Steel die	7833	465	25	25

Table 2: Steel die and constituent- and effective laminate material properties. The fibre volume fraction and steel die properties are supplied by *Fiberline*. The laminate constituent properties are found in *Cambridge Engineering Selector* (CES).

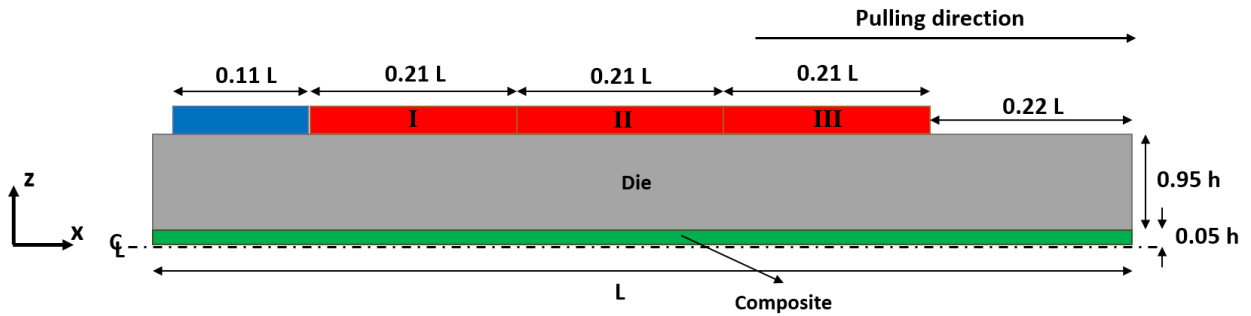

Figure 5: Normalized 2D schematic representation of half of the pultrusion domain (not to scale).

The domain illustrated in Fig. 5 is discretized using a non-uniform structured mesh of 98×27 CVs (including boundary condition ghost cells). By grouping the 98 CVs in the longitudinal direction as CV (1: 3, 4: 70, 71: 98), the mesh size is given by $\Delta x = L \left(\frac{1}{118}, \frac{1}{89}, \frac{1}{118} \right)$. Describing the 27 CVs in the thickness direction in the same manner, then the CVs (1: 2, 3: 7, 8: 27) have the mesh size $\Delta z = h \left(\frac{1}{334}, \frac{1}{100}, \frac{1}{20} \right)$. The boundary conditions are implemented as fixed surface temperature as described in [9].

A somehow arbitrary, normalized pulling speed of 0.5 and a time step of $\Delta t = 1$ s is used for the simulations. Hence, a Peclet number of $Pe = 2.9$ is calculated using (8) and the necessity of using the upwind scheme is confirmed. The corresponding Courant number (Cr) is calculated as

$$Cr = u \frac{\Delta t}{\Delta x} \quad (10)$$

hence, $Cr = 0.9$. In order to ensure numerical stability, the following condition must be met $Cr < 1$, [17].

6 RESULTS AND DISCUSSION

6.1 Modelling Results

The steady state solution is reached at $t = 6000s$. The calculated steady state temperatures for the whole 2D domain, including boundary conditions, are illustrated in Fig. 6a. It is observed that the temperature contour is highly affected by the convective nature of the pultrusion process (high pulling speed). In addition, it is observed that the exothermic heat generation is heavily increasing the temperatures inside the composite (and die) along $x = 0.35 - 0.55$ (longitudinal direction). The temperature contour inside the composite along the aforementioned length is illustrated in Fig. 6b.

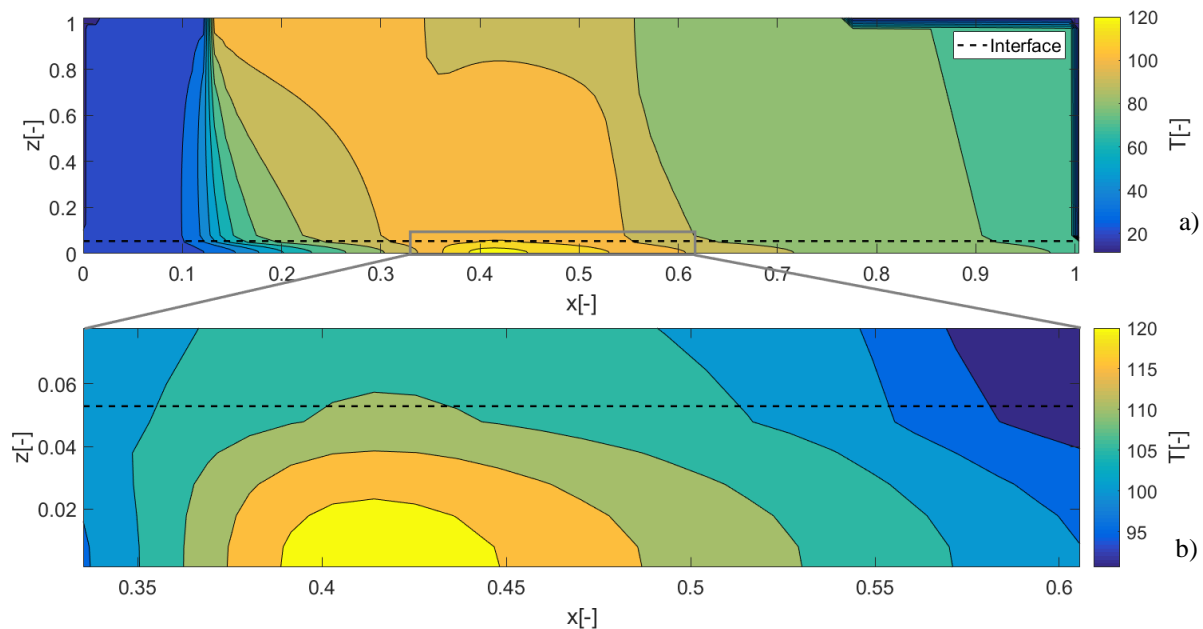

Figure 6: Normalized steady state temperature contour (not to scale): a) The whole 2D domain, b) Zoom, illustrating the exothermic heat generation inside the composite.

From Fig. 6b it is clearly observed how the temperature inside the composite exceeds the die temperature. Hence, the heat flow direction is reversed as compared with the prior positions along the longitudinal direction.

The steady state centreline and surface predictions (temperature and degree of cure) inside the composite is illustrated in Fig. 7. From Fig. 7a it should be noticed how the composite surface is rapidly heated up by the die at $x = 0.1-0.35$, while the centreline temperature is only gradually increasing due to the poor thermal conductivity of the resin (cf. Table 2). However, passing $x = 0.35$ the centreline temperature is exceeding the surface temperature due to a rapidly increase in exothermic heat generated by the curing of the resin (see slope of centreline degree of cure in Fig. 7b).

From Fig. 7b it is observed how the curing behaviour of the composite is predominantly outside-in up to a degree of cure of $\alpha \approx 0.7$. This outside-in curing is considered to be a classical behaviour for curing of thin laminates, where the heat flow is dominated by the die.

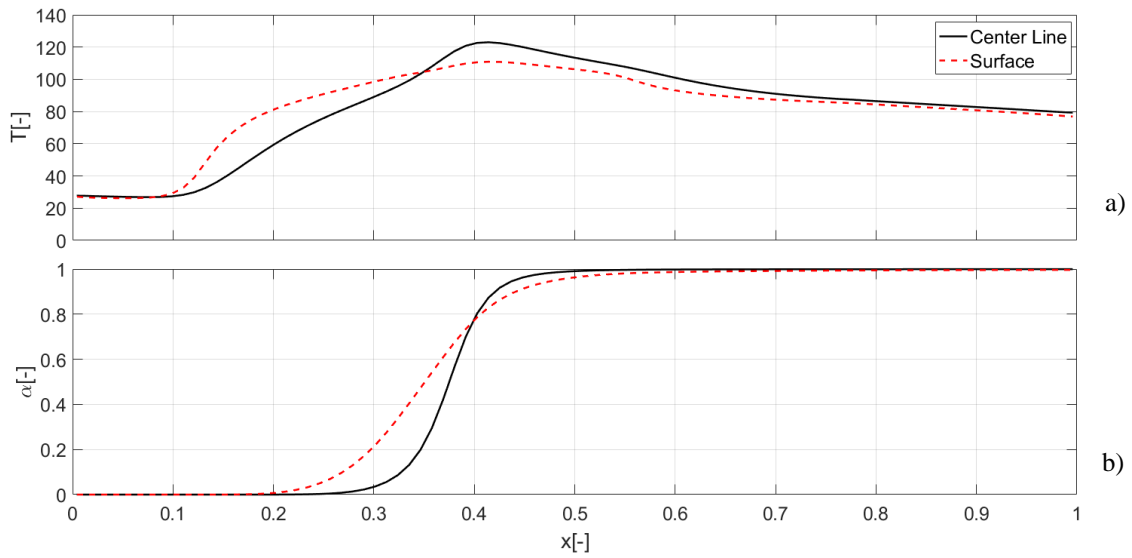

Figure 7: Comparison of normalized centerline and surface predictions:
a) temperature, b) degree of cure.

As mentioned above, the outside-in curing behaviour is only predominant up to a degree of cure of 0.7, after which the cure characteristics change to an inside-out behaviour during the last 0.3 degree of cure. This change in cure behaviour is illustrated in Fig. 8, where it should be noticed that the change happens at $x \approx 0.4$.

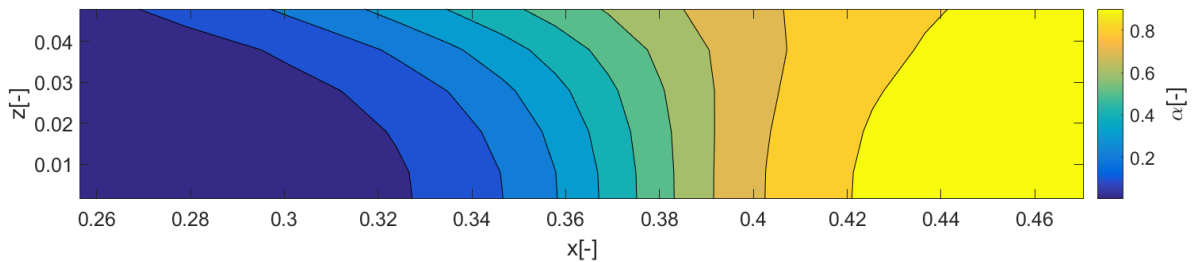

Figure 8: Normalized contour illustrating the evolution of the degree of cure (not to scale).

The sudden reverse in cure characteristics could possibly cause a built up of residual stresses, as described in [18].

6.2 Model Validation

The numerical model predictions are validated by comparison with temperature measurements on an industrial pultrusion line. The measurements were conducted using two thermocouples attached to fibres, which were approximately located at the centreline and a quarter into the composite (thickness direction) and in the middle considering the width direction (ensuring the assumption of 2D heat transfer to prevail). The position of the thermocouples along the longitudinal direction was estimated using the known pulling speed. The temperature measurements and the corresponding numerical predictions are compared in Fig. 9.

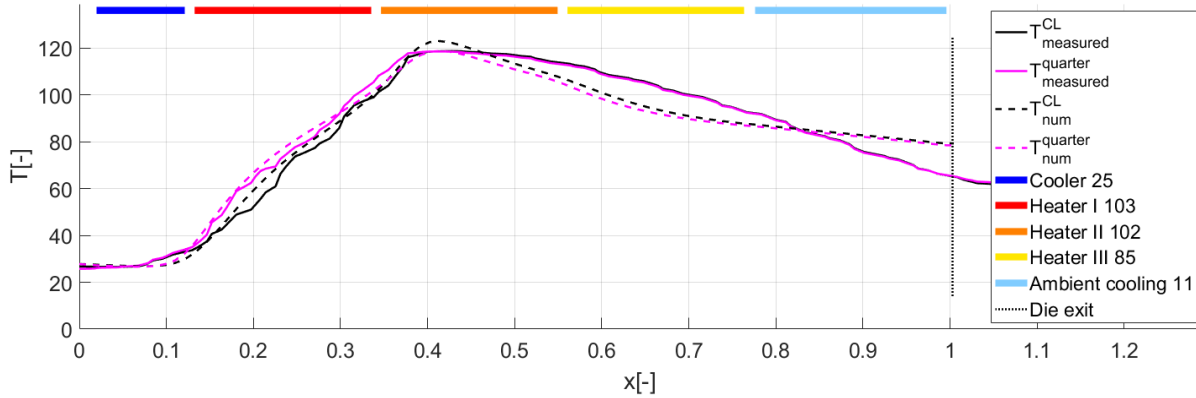

Figure 9: Comparison of measured and numerically predicted temperature profiles including the positions of cooler, heaters and ambient cooling along the longitudinal direction (normalized).

From the temperature comparison in Fig. 9 a good agreement is generally observed. It is seen that the difference between the two curves (CL and quarter) show the same trends for the numerical and measured curves. A very good agreement is observed under the cooler, the first heater and beginning of the second heater. In addition, it should be noticed how a good agreement is observed along $x = 0.3-0.5$. This is where most of the exothermic heat is generated (cf. Fig. 8) and the experimental cure kinetic parameters, obtained by DSC (cf. Table 1), are considered to capture the exothermic heat generation in a proper way, which is not straight forward. Considering the latter half of the pultrusion domain (longitudinal direction) a somehow inferior compliance is observed. From $x = 0.5-0.8$ the numerical predictions tend to predict too strong cooling of the composite by the die. This is most likely due to the poor assumption of perfect thermal contact at the interface, which is not considered to prevail in reality due to volumetric cure shrinkage. This deviation could possibly be accounted for by including position dependent thermal contact resistances as in [3]. The numerical temperature predictions close to the die exit tend to predict too high temperatures.

7 CONCLUSIONS

In the present study, a 2D thermo-chemical numerical model for simulations of the resin injection pultrusion of a flat profile is presented. The transient solution is modelled using the unconditionally stable 2D ADI method [9]. The predominant convective nature of the RIP process, due to a high pulling speed, necessitates upwind discretization of the convective/advective terms (spatial derivatives). The highly non-linear heat generation is included in the numerical simulations using experimental resin kinetics found by DSC.

A total heat of reaction of $H_{tr} = 282 \pm 12 \frac{kJ}{kg}$ for the industrial epoxy resin was obtained by integration over the DSC heat flow curves using linear baselines. A least squares non-linear regression analysis was conducted, fitting the CKM to the measured data. A very good compliance between the experimental cure rate and the corresponding cure kinetic model predictions was observed.

The numerical steady state temperature predictions inside the profile were validated by comparison with temperature measurements along the whole die length. In general, a good compliance was observed. The most significant deviations are considered to be a result of neglecting the effects of volumetric cure shrinkage leading to non-perfect thermal contact at the interface between the composite and the die [3].

The numerical simulations show a predominant outside-in cure behaviour, which is reversed considering the last 0.3 degree of cure. Hence, a built up of residual stresses is considered very likely [18]. This is the subject of ongoing investigations by the authors.

ACKNOWLEDGEMENTS

This work is part of the *Resin Injection Pultrusion (RIP)* project which has been granted by the Danish Council for Independent Research | Technology and Production Sciences (DFF/FTP), Grant no. DFF-6111-00112.

REFERENCES

- [1] G.L. Batch, C.W. Macosko, Heat Transfer and Cure in Pultrusion: Model and Experimental Verification, *AICHA J.*, **39**, 1993, pp. 1228-1241.
- [3] Z. Ding, S. Li, L.J. Lee, Influence of Heat Transfer and Curing on the Quality of Pultruded Composites. II: Modeling and Simulation, *Polymer Composites*, **23**, 2002, pp. 957-969.
- [3] I. Baran, C.C. Tutum, J.H. Hattel, The effect of thermal contact resistance on the thermosetting pultrusion process, *Composites Part B*, **45**, 2013, pp. 995-1000.
- [4] D.W. Peaceman, H.H. Rachford Jr., The numerical solution of parabolic and elliptic differential equations, *J. of the Society for Industrial and App. Math.*, **Vol. 3**, 1955, pp. 28-41.
- [5] I. Baran, J.H. Hattel, C.C. Tutum, Thermo-Chemical Modelling Strategies for the Pultrusion Process, *Applied Composite Materials.*, **20**, 2013, pp. 1247-1263.
- [6] M. Valliappan, J.A. Roux, J.G. Vaughan, Die and post-die temperature and cure in graphite/epoxy composites, *Composites Part B*, **27B**, 1996, pp. 1-9.
- [7] Y.R. Chachad, J.A. Roux, J.G. Vaughan, Three-Dimensional Characterization of Pultruded Fiberglass-Epoxy Composite Materials, *Journal of Reinf. Plast. Comp.*, **14**, 1995, pp. 495-512.
- [8] I. Baran, R. Akkerman, J.H. Hattel, Materials characterization of a polyester resin system for the pultrusion process, *Composites Part B*, **64**, 2014, pp. 194-201.
- [9] J.H. Hattel, *Fundamentals of Numerical Modelling of Casting Processes*, 1. edition., Polytekniske Forlag, Kgs. Lyngby, Denmark, 2005.
- [10] F.S. Rasmussen, Master Thesis: Thermomechanical Modelling of Composites Manufacturing, *Department of Mechanical Engineering – Tech. University of Denmark*, 2017.
- [11] D.D. Shin, H.T. Hahn, A consistent cure kinetic model for AS4/3502 graphite/epoxy, *Composites Part A*, **31**, 2000, pp. 991-999.
- [12] R.J. Varley, Reaction Kinetics and Phase Transformation During Cure of a Thermoplastic-Modified Epoxy Thermoset, *Macromolecular Materials and Eng.*, **292**, 2007, pp. 46-61.
- [13] Y. Leng, *Materials Characterization – Introduction to Microscopic and Spectroscopic Methods*, 2. Edition, Wiley-VCH, Weinheim, Germany, 2013.
- [14] S. Vyazovkin et al., ICTAC Kinetics Committee recommendations for collecting experimental thermal analysis data for kinetic computations, *Thermochimica Acta*, **590**, 2014, pp. 1-23.
- [15] S. Vyazovkin et al., ICTAC Kinetics Committee recommendations for performing kinetic computations on thermal analysis, *Thermochimica Acta*, **520**, 2011, pp. 1-19.
- [16] T.L. Bergman et al., *Fundamentals of Heat and Mass Transfer*, 7th edition, Wiley, R.R. Donnelley, Jefferson City, 2011.
- [17] A.N. Brooks, T.J.R. Hughes, Streamline Upwind/Petrov-Galerkin Formulations for Convection Dominated Flows with Particular Emphasis on the Incompressible Navier-Stokes Equations, *Computer Methods in Applied Mechanics and Engineering*, **32**, 1982, pp. 199-259.
- [18] T.A. Bogetti, J.W. Gillespie, Process-Induced Stress and Deformation in Thick-Section Thermoset Composite Laminates, *Journal of Composite Materials*, **26**, 1992, pp. 626-659.