

Technical University of Denmark



Intelligent Scheduling of a Grid-Connected Heat Pump in a Danish Detached House

Gianniou, Panagiota; Foteinaki, Kyriaki; Heller, Alfred; Rode, Carsten

Publication date:
2017

Document Version
Peer reviewed version

[Link back to DTU Orbit](#)

Citation (APA):

Gianniou, P., Foteinaki, K., Heller, A., & Rode, C. (2017). Intelligent Scheduling of a Grid-Connected Heat Pump in a Danish Detached House. Paper presented at Building Simulation 2017, San Francisco, United States.

DTU Library

Technical Information Center of Denmark

General rights

Copyright and moral rights for the publications made accessible in the public portal are retained by the authors and/or other copyright owners and it is a condition of accessing publications that users recognise and abide by the legal requirements associated with these rights.

- Users may download and print one copy of any publication from the public portal for the purpose of private study or research.
- You may not further distribute the material or use it for any profit-making activity or commercial gain
- You may freely distribute the URL identifying the publication in the public portal

If you believe that this document breaches copyright please contact us providing details, and we will remove access to the work immediately and investigate your claim.

Intelligent Scheduling of a Grid-Connected Heat Pump in a Danish Detached House

Panagiota Gianniou¹, Kyriaki Foteinaki¹, Alfred Heller¹, Carsten Rode¹

¹Department of Civil Engineering, DTU, Kgs. Lyngby, Denmark

Contact: pagian@byg.dtu.dk

Abstract

This study proposes a methodology for intelligent scheduling of a heat pump installed in a refurbished grid-connected detached house in Denmark. This scheduling is conducted through the coupling of a dynamic building simulation tool with an optimization tool. The optimization of the operation of the system is based on a price-signal considering a three-day period for different weather cases. The results show that the optimal scheduling of the system is successful in terms of reducing the peak load during times when electricity prices are high, thus achieving cost savings as well as maintaining good thermal comfort conditions. The proposed methodology bridges dynamic building modelling with optimization of real-time operation of HVAC systems offering a detailed model for building physics, especially regarding thermal mass and a stochastic price-based control.

Introduction

As the share of renewable energy sources (RES) in power generation is constantly increasing in many countries, imbalances arise between the supply and demand side. Specifically for Denmark, renewable energy is expected to cover about 80-85% of electricity consumption and up to 65% of district heating in 2020 (Danish Energy Agency, 2015). One of the main goals is that the entire energy supply is covered by RES by 2050. That calls for demand-side management (DSM) approaches that can facilitate the operation of the smart grid while enabling controllability of the electric loads.

The potential of buildings' participation in DSM approaches has been investigated, implementing strategies to reduce power consumption during peak periods (peak-shaving) and/or to shift the power consumption from peak periods to off-peak periods (load-shifting). There is a number of studies indicating the importance of the structural thermal mass of buildings, for example Reynders et al. (2013), while some others implemented DSM by adjusting the HVAC systems of the building, for example Arteconi et al. (2013) and Masy et al. (2015). There are also a few studies that tried to reschedule the operation of shiftable plug loads, such as dishwashers, washing machines and tumble dryers, as in D'hulst et al. (2015).

The two main types of control are direct control and indirect or price-based control. Schibuola et al. (2015)

concluded that HVAC systems will not undergo direct control in future smart grids due to discomfort issues that this might bring to the occupants. Thus, price response strategies will be the main focus of this study. Particularly in countries like Denmark, where power generation achieved by RES accounted for 25% of the adjusted gross energy consumption, which describes total observed energy consumption adjusted for fluctuations in climate with respect to a normal weather year (Danish Energy Agency, 2015), this leads to very low electricity spot prices or even negative ones. Thus, price-based control can achieve peak-shaving that is much needed by the grid to ensure decrease or displacement of peak loads.

Computational methods of design optimization have proven to be advantageous in several building studies according to Evins (2013). Optimization algorithms are mainly categorized into heuristic and meta-heuristic when it comes to building co-simulation. Heuristic algorithms include direct search such as pattern search and linear or non-linear programming. Meta-heuristic algorithms consist of evolutionary algorithms such as genetic algorithms (GA) or particle swarm optimization (PSO). So far, optimization in building modelling has been used with regards to building envelope, systems, energy generation and holistic approaches considering many aspects in building operation (Evins, 2013). Extensive studies have focused on optimizing the building envelope and dimensioning of the systems mostly during the design phase. The optimization of the control of the HVAC systems has been implemented in some studies. Particularly Zhou et al. (2003) investigated the minimization of electricity cost of varying cooling set-points for different algorithms and concluded on a most suitable one. Miara et al. (2014) investigated how heat pumps provided with heat storage and floor heating system may take advantage of real-time pricing. The authors determined that the most important parameter to ensure this was the water heat storage tank. However, the flexibility that thermal mass, which is embedded into the building structure, can offer along with demand response management of the heating systems, have not been thoroughly discussed. Especially when using reduced order models or grey-box models, many optimization techniques and algorithms can ensure their feasibility. Their application has not been extensively highlighted though, in cases of flexible operation of HVAC systems in residential buildings. Particularly in the case of white-box building models, which describe building physics and

heat transfer mechanisms in full detail, little effort has been made to use them as basis for optimal scheduling of the HVAC systems based on electricity pricing. This is mainly due to their complexity, which impedes their coupling with advanced optimization tools. However, the potential that the thermal mass of the building gives with regards to energy flexibility is crucial to such studies and should be modelled with every detail possible.

The current study aims at developing a methodology for optimally scheduling the systems of a grid-connected single-family house equipped with an air-to-water heat pump and low temperature radiators based on a price response strategy. This strategy will indicate the potential of the systems for optimization, which will define a generic methodology while enabling the utilization of the building's thermal mass that can be applied in every residential building with similar HVAC systems.

Model description

The current analysis was conducted by use of a building model. This corresponds to a typical Danish single-family house (SFH) built between 1961-1972 (Figure 1), which is the most common type of SFH in Denmark according to Danmarks Statistik (2016). The properties of the building envelope and systems have been created according to TABULA database (2016). The building area is 153m², while the glazing covers an area of 34m². Its building envelope has been extensively renovated and the average U-value of the building is 0.27 W/m²K. The material layers that consist the building components can be seen in Table 1. The house contains an air-to-water heat pump (HP) of 13 kW with COP of 3.5. The heat emission system installed is a hydronic one with low-temperature water radiators. The controller of the hydronic system is a thermostat set at 21°C with 2°C deadband based on the operative temperature.

Table 1: Material layers

Building component	Layer material	Thickness (m)	U-value (W/m ² K)
External walls	Brick	0.05	0.13
	Light insulation	0.25	
	Brick	0.05	
Roof	Light insulation	0.34	0.10
	Wood	0.03	
	Gypsum	0.013	
Floor	Wood	0.02	0.12
	Light insulation	0.28	
	Gypsum	0.02	

Deterministic profiles were created for the internal gains. The occupants living in the house were assumed to be two according to data from Danish Statistics (Danmarks Statistik, 2016) following a typical house living profile (Figure 2) and with sedentary activity level (met-value=1.2) according to DS/EN 15251 (2007). Their clothing was variable ranging from 1 during the winter season to 0.5 for the summer season. The schedules of

equipment and lighting can also be found in Figure 2. Internal blinds were drawn in cases of excessive solar radiation. It was also assumed that windows started to open when indoor temperature reaches 25°C and opened fully at 27°C. There was no mechanical ventilation or cooling installed in the building. The infiltration rate was 0.2 ACH representing a quite air-tight refurbished envelope. The location was set to Copenhagen, Denmark. The main façade of the house was assumed to be oriented towards the south. The weather file used was the Danish Design Reference Year (DRY) (DMI, 2013).

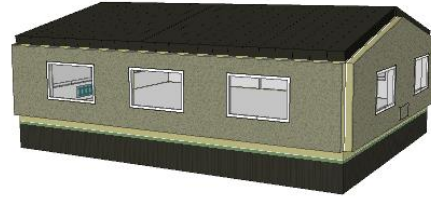

Figure 1: Design of examined SFH

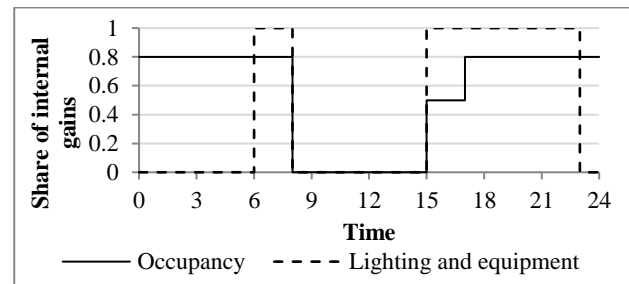

Figure 2: Daily schedule for internal gains

Since emphasis will be placed on the utilization of the thermal mass of the building in the present study, the heat transfer mechanisms taking place inside the building structure are important. The wall model used is a finite difference model of multi-layered components. Each material layer is discretized into four nodes. Thus, it can provide accuracy when alternative models, such as RC-networks, fail to. Furthermore, nonlinear effects in the thermal dynamics of buildings, which are usually oversimplified in RC-networks (Thavlov and Bindner, 2015), (Zong et al., 2017), are described in detail in the current model.

Methodology

In this paper, a price-based control strategy for the management of the heat pump was implemented that enabled the exploitation of dynamic electricity prices and thus management of the energy load according to the grid's imbalances. In this way, the interaction of the detached house with the grid was improved. The scheduling of the HP comprised two parts: the control of the system, and its optimization.

The scheduling of the heat pump was carried out considering an advanced controller for the radiators. This can be seen in Figure 3. The base heating setpoint was set to 20°C. An additional controller, which contained an algorithm to smooth its output as an approximation to a P-

controller so that no events (abrupt turn-ons and offs) were created, was added in the loop to allow for the system's flexibility when the electricity prices were low. Therefore, the operation of the HP was forced to increase during low-tariff hours. The hourly tariff concept was assumed to reflect the lack of or excess of RES energy in the grid and thus represent the stress on the grid (Dar et al., 2014). The low electricity prices were defined as the ones that were lower than the average electricity price of the specific month. This means that when the electricity price was low, a positive deadband of 3°C was added to the base setpoint, resulting in 23°C upper threshold, which allowed the system to take advantage of the low prices. In this way, the increase in the heating setpoint would enable heat to be stored into the thermal mass during low price periods, and be released back to the room when prices were higher. The electricity price signal was imported into the model as a source file connected to the P-controller. The proportional band of the P-controller was set to -0.5 as this referred to heating mode. The capability of the system to keep the indoor environment within comfort conditions was a significant advantage of the selected control strategy. According to EN/DS 15251 (2007), Category II of acceptable thermal comfort ranges from 20-25°C.

The optimization was defined as minimization of the operating cost of the HP. This cost depended on the variable electricity prices and on the consumption of the HP. The cost-optimal control of the heat pump on a 3-day horizon would ensure cost savings in the electricity bill along with the desired peak shavings in the heat load of the building. Also, the 3-day horizon was selected so that any phenomena of cumulative heat storage into the thermal mass can be observed. Due to increased computation time, it was not selected to investigate a longer period. It has to be clarified that no electricity was assumed to be sold back to the grid or modelled in this case for simplification reasons.

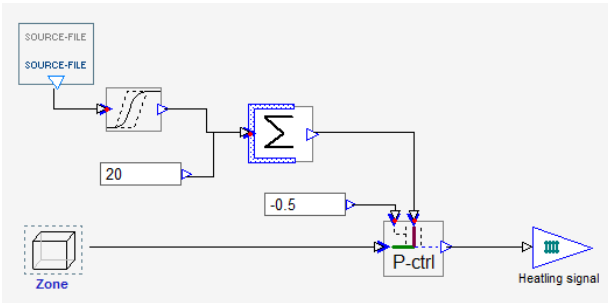

Figure 3: Control of heating system based on price signal

The optimization problem of the intelligent scheduling of the heat pump according to the price signal was formulated as following:

$$\text{Minimize } C_{HP} \quad (1)$$

where C_{HP} is the operating cost of the HP, calculated as following:

$$C_{HP} = p_{el} \cdot W \quad (2)$$

where p_{el} is the total electricity price and W is the energy consumption of the HP.

The optimization of the system operation was conducted through the boiler schedule which was characterized by ten variables per day, b_i , corresponding to the schedule of the part load operation of the HP. This means that a different schedule of the HP operation was optimized for each day.

$$b_i \in [0,1] \text{ for } i = 1 \dots 30 \quad (3)$$

The optimization was conducted with the use of the open-source software MOBO. MOBO is a generic freeware designed to handle single-objective and multi-objective optimization problems with continuous or discrete variables (Rosli et al., 2016). It provides the possibility to be coupled to building performance simulation tools, while selecting different algorithms to perform the calculations. Furthermore, MOBO has the feature of running multiple simulations in parallel, thus reducing the overall computation time with a factor equal to the number of threads available in the computer. In this case, different optimization algorithms were selected, and they were compared upon the optimal solution and the number of runs. In particular, a deterministic algorithm (Hooke-Jeeves), two genetic algorithms (NSGA-II, Omni-optimizer) and a hybrid one (GA and Hooke-Jeeves) were tested. As defined in Wetter and Wright (2004), GA are algorithms that operate on a finite set of points, called a population. The different populations are called generations. They are derived on the principles of natural selection and incorporate operators for fitness assignment, selection of points for recombination, recombination of points, and mutation of a point. The simple GA iterates either until a user-specified number of generations is exceeded, or until all iterates of the current generation have the same cost function value (Wetter and Wright, 2004). Initially, the optimization algorithms were implemented having the same solver settings. These were 8 populations, 20 generations, 0.05 mutation probability and 0.9 cross-over probability. The meaning of the cross-over probability is that when this is not met, the individuals do not continue to the new population as explained in Evins et al. (2010). The crossover process continues until the new population is full. The reason for using a small population size was to reduce computation time. The deterministic algorithm that was tested does not enable parallel computing, thus being significantly slower. The settings of the deterministic algorithm were $\rho=0.05$ (convergence parameter) and $\epsilon=0.01$ (minimum criterion to stop the search).

Furthermore, different solver settings were applied to determine their effect on achieving the optimal solution. Based on the cost-optimal solution and the number of simulations carried out until convergence was reached, one optimization algorithm was selected and tested upon its accuracy for various numbers of generations. Then, the solver settings that reached the biggest cost reduction were selected and implemented into the building model. The schedule for the boiler/HP operation was thus defined according to the optimal solution. These results were

compared to the ones of the reference case with normal operation of the HP, as previously described in the model description.

Simulation

The simulation was run in IDA ICE Version 4.7 (EQUA, 2013) using MOBO. The building was simulated as a single-zone model. The reference model was initially run with the DRY weather file. Three climate cases were selected out of the entire simulation period, the coldest 3-day period of the heating season (January) with a mean ambient temperature of -4°C , the warmest 3-day period of the heating season (September) with a mean ambient temperature of 11°C and an intermediate one (April) when the average ambient temperature was 3°C .

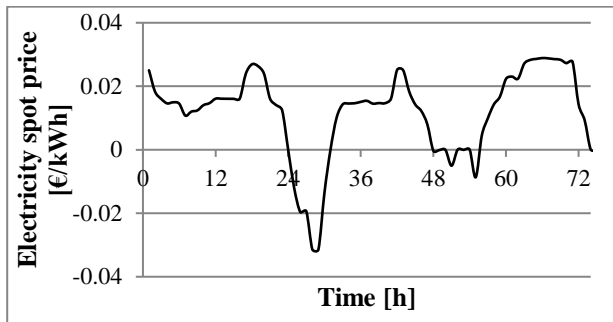

Figure 4: Electricity spot prices over 3 days

The prices for electricity were set in the model through a stochastic profile reflecting real electricity prices in 2015 according to the Nordic electricity market Nord Pool for East Denmark. During this period, wind power generation accounted for 74% of the total electricity production, which explains the low electricity prices that comprise the price signal that was coupled to the IDA ICE model. These prices reflect the total electricity prices consisting of variable el-spot prices (commercial), which account for 32% of the total price in Denmark, while the remaining 68% are fixed taxes for local network, grid and system tariffs, public service obligation tariff and further subscriptions to electrical companies based on the Association of Danish Energy Companies (2015). The total electricity prices were used in the model so that they correspond to the ones that electricity customers have to

pay. The same price-signal was used for all three cases of weather data to ensure comparability, so it has not been correlated to the climate data. Figure 4 presents the electricity spot prices during this 3-day period. The negative prices indicate the surplus of wind power generation during these days.

Result analysis and discussion

As mentioned before, different optimization algorithms were tested in MOBO in order to determine which one to select based on the biggest cost reduction they could achieve. The selected genetic and deterministic algorithms were implemented and tested for the three different weather data having the same solver settings, as described in the Methodology section. The implemented algorithms are presented in Table 2. A detailed explanation of all the algorithm parameters is beyond the scope of this paper and we refer the readers to Wetter and Wright (2003). The cost-optimal solution refers to the minimum cost (€) that each optimization algorithm achieved which means the total operating cost of the HP needed to heat up the building for the examined 3 days.

Due to the increased number of variables used in the optimization problem, some discontinuities could be expected in the cost function which would make optimization rather difficult to be achieved (Wetter, 2004). For this reason, different optimization algorithms were tested, some of which (i.e. Hooke-Jeeves) are less likely to converge to a discontinuity far from the optimal solution (Wetter, 2011). Moreover, the total cost reduction observed might be limited for the above-described reasons and is not assessed per se but in comparison with the rest of the results. Furthermore, some uncertainty in the results has to be considered due to randomness of the optimization. The hybrid algorithm, GA and Hooke-Jeeves, proved to be the best one among the rest, even though the differences were very small, calculating the biggest cost reduction in all three weather cases. It has to be noticed that the hybrid algorithm led to a higher number of simulations, due to which it converged to a lower cost-optimal solution. Thus, it was selected to run some further analysis on the impact that the number of generations has on achieving the optimal solution.

Table 2: Results of different optimization algorithms

Optimization algorithm	Type of algorithm	Cost-optimal solution [€]	Simulations until convergence (output)	Weather data
NSGA-II	Genetic (evolutionary)	1.802	144	Cold
		0.787	152	Intermediate
		0.008	152	Warm
Hooke-Jeeves	Deterministic (pattern-search)	1.775	221	Cold
		0.778	166	Intermediate
		0.008	60	Warm
GA and Hooke-Jeeves	Hybrid	1.774	311	Cold
		0.778	363	Intermediate
		0.007	311	Warm
Omni-optimizer	Genetic (evolutionary)	1.806	152	Cold
		0.780	152	Intermediate
		0.007	152	Warm

Three numbers of generations were applied to the hybrid algorithm being comprised of GA and Hooke-Jeeves, and are presented in Table 3 along with the number of simulations and the solution they resulted in. It can be observed that the higher the number of generations and the more simulations conducted, the bigger cost reduction was achieved, as it was expected. Therefore, the optimal solution found with 100 generations for each weather case was used for the following analysis. However, it has to be pointed out that even though a scenario of 100 generations leads to approximately twice as many simulations as the one of 50 generations, the cost reduction is not significantly bigger. Specifically, this was 2% for the cold and intermediate weather data and 1% for the warm case, (Table 3). Therefore, it was decided not to investigate an even bigger number of generations.

Table 3: Impact of generations on optimal solution

GA and Hooke-Jeeves	Cost-optimal solution [€] (Number of simulations)		
	Cold	Intermediate	Warm
Generations			
25	1.7741 (311)	0.7778 (363)	0.0075 (311)
50	1.7727 (512)	0.7771 (568)	0.0074 (800)
100	1.7418 (913)	0.7612 (909)	0.0073 (1491)

Figure 5 shows the power consumption for the reference and optimized case for each of the weather cases. As it was expected, the pattern is different for the different climate cases examined. For the cold weather, when using the thermostat as in the reference case, the HP turned on and off in very small intervals, in order to cover the high demand, which results in high power peaks. On the other hand, for the optimal case, the power consumption presented a considerably more smooth pattern, which was fully in line with the price signal. This is also attributed to the smoothing effect that the controller applied in the optimal scenario has. There were small parts of the load that were shifted towards a different timing than in the

reference case, but this schedule mainly achieved considerable peak shaving. It is clear that the optimization was conducted successfully, as during times with low electricity prices, the HP was forced to increase its part load and vice versa. For the intermediate climate case, it can be seen that the power consumption pattern is similar for the reference and optimal cases. The time when the power consumption peaks is almost identical, but still there was peak shaving achieved with the optimal case and the operation pattern of the HP is more smooth. This means that continuous on/off's are avoided, which would lead to a decrease in HP's lifetime and inefficient operation. For the warm climate case, it is obvious that the energy demand is almost zero, so the difference between the two cases is marginal. This minimum heat load left no room for the optimization to take place.

Table 4. Total energy consumption results

Weather data	Total energy consumption (kWh)	
	Reference case	Optimal case
Cold	191	180
Intermediate	92	104
Warm	8.80E-05	8.70E-05

Regarding the total energy consumption, the results were different for the different climate cases. These are presented in Table 4. For the cold climate, there was an energy consumption reduction of 6% with the optimal case, while for the intermediate climate there was a 13% increase for the optimal case. This indicates that when implementing a DSM strategy, i.e. peak shaving, this might result in an overall over-consumption. However, the goal of this strategy is to use the energy produced from RES, which is, in this study, reflected in the low prices. So, the focus is not to achieve energy minimization, but to "force" the operation of the HP to follow the production pattern of renewable energy in the energy system, while maintaining the thermal comfort and achieving cost savings for the occupants. As previously mentioned, the heat demand for the warm climate is minor, so there is only 1% decrease in the total energy consumption after the optimal case was applied.

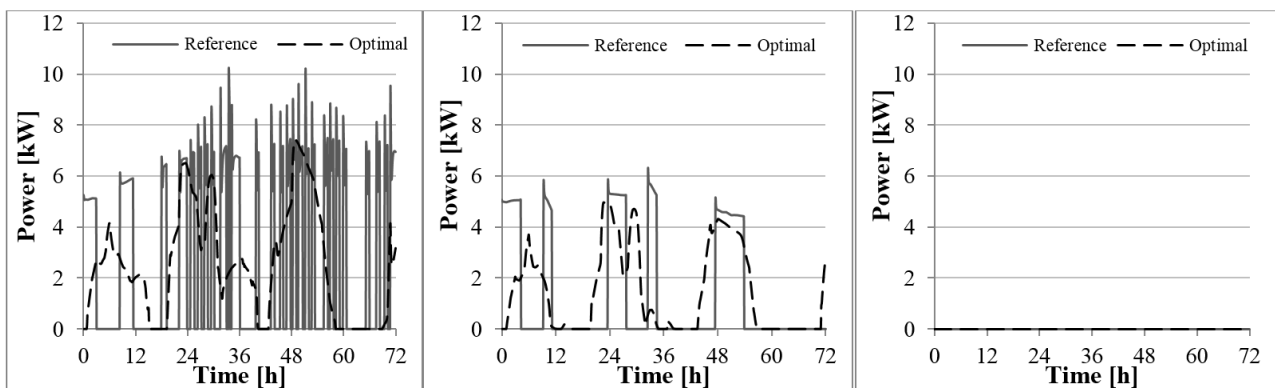

Figure 5: Power results for the optimized scheduling of the HP and the reference operation for cold weather data (left), intermediate (middle) and warm (right)

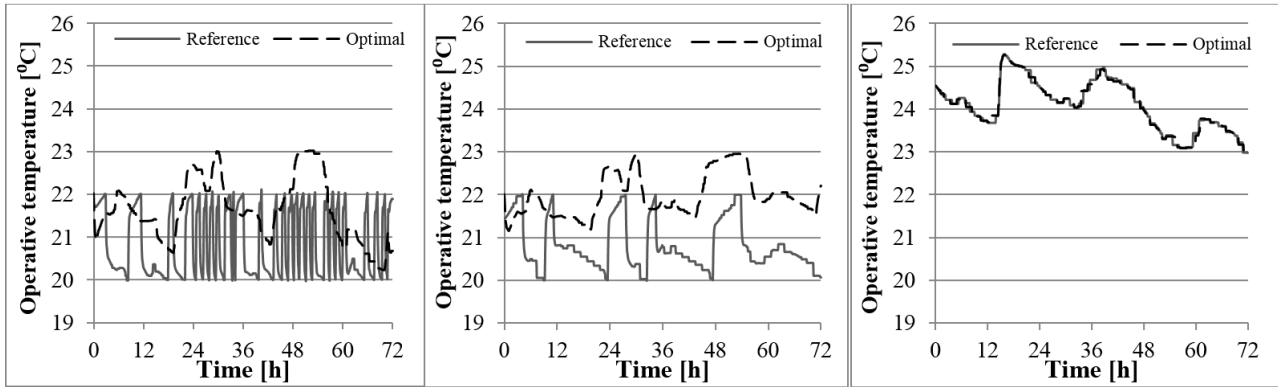

Figure 6: Operative temperature results for the optimized scheduling of the HP and the reference operation for cold weather data (left), intermediate (middle) and warm (right)

As far as cost reduction is concerned, the results varied, too, with regards to the different climate cases and can be seen in Table 5. In the cold weather case, optimally scheduling the HP resulted in 42% decrease in the total operating cost of the HP for the examined 3-day period. In the intermediate case, the cost savings were 22% compared to the reference operation of the HP, while in the warm weather case these were significantly lower, approximately 13%, as it was expected.

Table 5. Operating cost results of the HP for 3 days

Weather data	Total operating cost (€)	
	Reference case	Optimal case
Cold	2.998	1.742
Intermediate	0.979	0.761
Warm	0.008	0.007

Regarding peak shavings, which is the main goal of this demand side management approach, the results showed a clear decrease in peak consumption at the optimal case both for the cold and the intermediate weather. Taking the highest peak in power for each case, there was a reduction of 27% (2.75 kW) for the cold weather and 21% (1.32 kW) for the intermediate weather (Figure 5). This was achieved due to the smoother operation pattern of the heat pump that shifted parts of the load in time, which led to reduced peak demand. The magnitude of the potential peak decrease would always depend on the price signal, but the main outcome is that the implemented control is an effective peak shaving strategy.

Figure 6 presents the operative temperature for the reference and optimized cases for each of the weather cases. It can be observed that there is a trend for the optimal cases to have higher operative temperature than the respective of the reference cases at all climate cases. This can be explained by the control of the heating system, which was able to increase the setpoint up to 23°C when the electricity prices were low. It has to be pointed out that the electricity prices according to which the optimal scheduling of the HP was conducted in the three weather cases were found to be low compared to the average monthly price, which resulted in utilization of the increased heating setpoint most of the time. If a different threshold was used instead of the monthly average

electricity price, the price signal might not be characterized as low most of the time and the results would be somewhat different as the decision to add the deadband to the base setpoint would alter. The lowest threshold of the thermal setpoint (considering the given deadband) was set to be equal for the reference and the optimal cases (20°C), so that they both retain similar thermal comfort conditions. Furthermore, there is a clear correlation between the power consumption pattern and the operative temperature pattern. This explains why the temperature of the reference case of the cold climate had frequent fluctuations, whereas the temperature of the optimal case of the cold climate and both cases of the intermediate climate had a smooth pattern. Due to the cold external temperatures that reached -18°C, the HP was forced to switch on and off very frequently creating high peaks in order to maintain the desired indoor temperature. In the intermediate weather case, the significantly higher ambient temperatures allowed a more flexible operation of the HP. In the warm climate case, there was almost no difference observed in the operative temperatures between the optimal and the reference case since the HP operated for a very short time. In all cases, the operative temperature stayed within the acceptable limits of EN/DS 15251 ensuring that with the applied control and cost optimization, the thermal comfort for the occupants was not compromised.

This can be verified by the amount of occupancy hours into the different comfort categories, which were in all cases within the acceptable categories according to EN/DS 15251, as it can be seen in Table 6. In particular, Table 6 indicates the cumulative share of occupancy hours that fell into the three comfort categories according to EN/DS 15251. Category IV is not presented since no occupancy hours belonged to that. The optimized scheduling of the HP increased the amount of occupancy hours belonging to comfort Category I for the cold and intermediate weather case, while slightly decreased these for the warm weather case. Overall, the optimized operation of the HP maintained the good thermal comfort corresponding to the design conditions of the heating system in all three weather cases.

Table 6: Thermal comfort assessment for optimal scheduling of HP

Weather data	Cold		Intermediate		Warm	
	Opt.	Ref.	Opt.	Ref.	Opt.	Ref.
Case						
Comfort category	Share of occupancy hours (%)					
I (best) (21-25°C)	71	40	100	26	78	100
II (good) (20-25°C)	100	98	100	100	100	100
III (acceptable) (18-25°C)	100	100	100	100	100	100

Summing up, the optimization problem has been solved using MOBO coupled with IDA ICE. The simulations were performed on a computer with Intel i7 4-core processor clocking at 2.1 GHz and 8 GB of RAM. The average total time of solving was 7250 seconds for the cold and warm weather case and 7460 seconds for the intermediate one. In this specific case, the optimization problem was solved for a three-day period.

It has to be pointed out that the goal of this study was the proposal of a methodology to schedule the HP operation intelligently using building performance simulation tools according to the grid's imbalances that are reflected on the price signal and not the investigation of optimization techniques. In addition to this, the complicated building model and the large number of continuous variables used in the optimization problem increased significantly the computation time. On the other hand, the advanced building model that was used modelled accurately the thermal building physics mainly of the thermal mass and the complicated heat transfer mechanisms that take place during the charging or discharging of the thermal mass. These were critical to estimate the flexible operation of the HP.

Due to increased computation time, it was chosen to investigate a three-day design period for each weather case instead of a whole- year simulation that would be more representative. The optimization horizon was not restricted to one day, since the authors wanted to investigate any heat storage mechanisms into the thermal mass of the building, which are cumulative over time. Furthermore, the proposed methodology refers to future energy market designs, where the optimization of individual buildings' heating or cooling systems based on price signals will be possible. In this case, day-ahead prices will be available, so the optimization problem will be solved only for the following day, which will result in shorter computation time. However, attention should be paid to the initial and final conditions of the thermal model, so that they are consistent with the ones of the previous and following day.

Computationally expensive simulations also led to tight solver settings (small number of populations and low mutation probability), which increased the chances of not converging to a stationary minimum point of the cost function.

The positive 3°C deadband provided to the base heating setpoint that allowed for the system flexibility was selected such that the thermal comfort of occupants was not compromised with the optimized scheduling of the heating system. If a looser comfort threshold was to be achieved, this deadband could be further expanded so that lower operative temperatures than 20°C should be allowed. Furthermore, different price signals could have been applied to the case so that an estimate of the range of peak and power savings could be made and also a realistic correlation to the weather data would be possible. Lastly, the use of historical weather data for the examined period would have resulted in much more clear optimization results and would have avoided uncertainty. Hence, they ought to replace the DRY weather file as a next step to this study.

Conclusion

In this study, the cost optimization of the control of a HP in a detached Danish house was investigated. A dynamic building performance simulation tool was coupled to an optimization software. A hybrid genetic algorithm was selected as the most suitable one to achieve the biggest cost reduction of the operation of the HP. The optimal scheduling of the HP that was achieved based on a price signal for three weather data was compared to the reference case, which was normal operation of the HP system. The comparison was made with regards to power peak shavings, cost savings, operative temperature and thermal comfort. The results showed that the optimization was conducted successfully, as the price-based control managed to reduce the peak loads during high price times and increase the energy load during the low price times. This resulted in a smoother pattern for the operation of the HP for the cold and intermediate weather data. In the warm weather case, the very low heating demand left no room for optimization. Furthermore, the optimal scheduling of the HP maintained good thermal comfort of the occupants with regards to the operative temperature. The operative temperatures during the optimal scheduling of the system were maintained in a good comfort category according to EN/DS 15251. Even though the detailed building model that was used increased the number of variables in the optimization problem and the computation time, it modelled the heat dynamics into the thermal mass sufficiently well, which allowed for the flexible operation of the HP.

Finally, the three selected weather cases represented different climatic conditions during a heating season in Denmark. The cold and the intermediate weather cases proved to be representative of extreme and mild winter weather conditions and enabled the optimization of the HP. The warm weather data could not be considered for the optimal scheduling of the HP, since the heat demand was very low. Therefore, should a holistic overview of the intelligent scheduling of a HP in a similar building and climate be given, a combination of the two aforementioned weather data has to be considered.

Acknowledgements

This study is part of the Danish research project CITIES (Centre for IT-Intelligent Energy Systems in cities) and EnergyLab Nordhavn. The authors would like to thank Mika Vuolle, Erkki Karjalainen and Ala Hasan for their useful comments on MOBO and Rune Korsholm Andersen for his help regarding the implementation in IDA ICE.

References

- Arteconi, A., Hewitt, N. J., Polonara, F. (2013). Domestic demand-side management (DSM): Role of heat pumps and thermal energy storage (TES) systems. *Applied Thermal Engineering*, 51(1–2), 155–165.
- Association of Danish Energy Companies (2015). Electric Utility tariffs and electricity prices (Danish title: Dansk Energi. Elforsyningens tariffer & elpriser)
- D'hulst, R., Labeeuw, W., Beusen, B., Claessens, S., Deconinck, G., Vanthournout, K. (2015). Demand response flexibility and flexibility potential of residential smart appliances: Experiences from large pilot test in Belgium. *Applied Energy*, 155, 79–90.
- Danish Energy Agency (2015). Danish energy and climate outlook. Published in December 2015 by the Danish Energy Agency, Copenhagen, Denmark.
- Danmarks Statistik (accessed 2nd December 2016). <https://www.statbank.dk/statbank5a/default.asp?w=1920>
- Dar, U. I., Sartori, I., Georges, L., Novakovic, V. (2014). Advanced control of heat pumps for improved flexibility of Net-ZEB towards the grid. *Energy and Buildings*, 69, 74–84.
- DMI, Danish Meteorological Institute (2013). Danish Ministry of Climate, Energy and Building: 2001-2010 Danish Design Reference Year. Technical Report 13-19.
- EN/DS 15251 (2007). Indoor environmental input parameters for design and assessment of energy performance of buildings addressing indoor air quality, thermal environment, lighting and acoustics.
- Evins, R. (2013). A review of computational optimisation methods applied to sustainable building design. *Renewable and Sustainable Energy Reviews*, 22, 230–245.
- Evins, R., Pointer, P., Vaidyanathan, R. (2010). Configuration of a genetic algorithm for multi-objective optimisation of solar gain to buildings. In: *Proceedings of the genetic and evolutionary computation (GECCO)*. New York, NY, USA, 1327–1328.
- EQUA (2013). IDA Indoor Climate and Energy. User Manual. Version 4.5. <http://www.equaonline.com/iceuser/pdf/ICE45eng.pdf>.
- Masy, G., Georges, E., Verhelst, C., Lemort, V., Andre, P. (2015). Smart grid energy flexible buildings through the use of heat pumps and building thermal mass as energy storage in the Belgian context. *Science and Technology for the Built Environment*, 4731(August), 800–811.
- Miara, M., Günther, D., Leitner, Z. L., Wapler, J. (2014). Simulation of an Air-to-Water Heat Pump System to Evaluate the Impact of Demand-Side-Management Measures on Efficiency and Load-Shifting Potential. *Energy Technology*, 2(1), 90–99.
- Reynders, G., Nuytten, T., Saelens, D. (2013). Potential of structural thermal mass for demand-side management in dwellings. *Building and Environment*, 64, 187–199.
- Rosli, E. M.A.M., Sopian, K., Mat, S., Sulaiman, M. Y. (2016). Renewable Energy in the Service of Mankind Vol II. *Selected Topics from the World Renewable Energy Congress WREC 2014, I*, 583–590.
- Schibuola, L., Scarpa, M., Tambani, C. (2015). Demand response management by means of heat pumps controlled via real time pricing. *Energy and Buildings*, 90, 15–28.
- TABULA WebTool (accessed 30th November 2016). <http://webtool.building-typology.eu/#bm>.
- Thavlov, A., Bindner, H. (2015). A Heat Dynamic Model for Intelligent Heating of Buildings. *International Journal of Green Energy*, 12, 240–247.
- Wetter, M. and Wright, J. (2003). Comparison of a generalized pattern search and a genetic algorithm optimization method. In Augenbroe, G. and Hensen, J., editors, *Proc. of the 8-th IBPSA Conference*, volume III, pages 1401-1408, Eindhoven, NL.
- Wetter, M. and Wright, J. (2004). A comparison of deterministic and probabilistic optimization algorithms for nonsmooth simulation-based optimization. *Building and Environment*, 39, 989–999.
- Wetter, M. (2011). GenOpt, generic optimization program, user manual, version 3.1.0. Lawrence Berkeley National Laboratory, Berkeley, CA, USA.
- Zhou, G., Ihm, P., Krarti, M., Liu, S., Henze, G. (2003). Integration of an internal optimization module within EnergyPlus. In: *Proceedings of the building simulation*, Eindhoven, Netherlands.
- Zong, H., Bönning, G. M., Santos, R. M., You, S., Hu, J., Han, X. (2017). Challenges of implementing economic model predictive control strategy for buildings interacting with smart energy systems. *Applied Thermal Engineering*, 114, 1476–1486.