

Engineering geology of British rocks and soils

Gault Clay



Technical Report WN/94/31

**Engineering geology of British
rocks and soils:
Gault clay**

A Forster, P R N Hobbs, A C Cripps, D C
Entwistle, S M M Fenwick, M R Raines,
J R Hallam, L D Jones, S J Self and
J L Meakin

BRITISH GEOLOGICAL SURVEY

TECHNICAL REPORT WN/94/31

Engineering geology of British rocks and soils: Gault clay

A Forster, P R N Hobbs, A C Cripps, D C Entwistle,
S M M Fenwick, M R Raines, J R Hallam, L D Jones,
S J Self and J L Meakin

Cover illustration

Outcrop of the Gault and Upper
Greenstone in England

Authors

**Forster, A, Hobbs, P R N, Cripps,
A C, Entwistle, D C, Fenwick,
S M M, Raines, M R, Hallam,
J R, Jones, L D, Self, S J, and
Meakin, J L.**

Maps and diagrams use topography
based on Ordnance Survey mapping

Bibliographic reference

FORSTER, A and others. 1994.
Engineering geology of British
rocks and soils: Gault clay. *British
Geological Survey Technical
Report WN/94/31.*

BRITISH GEOLOGICAL SURVEY

The full range of Survey publications is available from the BGS Sales Desk at the Survey headquarters, Keyworth, Nottingham. The more popular maps and books may be purchased from BGS-approved stockists and agents and over the counter at the Bookshop, Gallery 37, Natural History Museum, Cromwell Road, (Earth Galleries), London. Sales Desks are also located at the BGS London Information Office, and at Murchison House, Edinburgh. The London Information Office maintains a reference collection of BGS publications including maps for consultation. Some BGS books and reports may also be obtained from HMSO Publications Centre or from HMSO bookshops and agents.

The Survey publishes an annual catalogue of maps, which lists published material and contains index maps for several of the BGS series.

The British Geological Survey carries out the geological survey of Great Britain and Northern Ireland (the latter as an agency service for the government of Northern Ireland), and of the surrounding continental shelf, as well as its basic research projects. It also undertakes programmes of British technical aid in geology in developing countries as arranged by the Overseas Development Administration.

The British Geological Survey is a component body of the Natural Environment Research Council.

Keyworth, Nottingham NG12 5GG

☎ 0115-936 3100

Telex 378173 BGSKEY G
Fax 0115-936 3200

Murchison House, West Mains Road, Edinburgh, EH9 3LA

☎ 0131-667 1000

Telex 727343 SEISED G
Fax 0131-668 2683

London Information Office at the Natural History Museum, Earth Galleries, Exhibition Road, South Kensington, London, SW7 2DE

☎ 0171-589 4090

Fax 0171-584 8270

☎ 0171-938 9056/57

St Just, 30 Pennsylvania Road, Exeter EX4 6BX

☎ 01392-78312

Fax 01392-437505

Geological Survey of Northern Ireland, 20 College Gardens, Belfast BT9 6BS

☎ 01232-666595

Fax 01232-662835

Maclean Building, Crowmarsh Gifford, Wallingford, Oxfordshire OX10 8BB

☎ 01491-838800

Telex 849365 HYDROL G
Fax 01491-692345

Parent Body

Natural Environment Research Council

Polaris House, North Star Avenue, Swindon, Wiltshire

SN2 1EU

☎ 01793-411500

Telex 444293 ENVRE G
Fax 01793-411501

‘In civil engineering projects the largest element of technical and financial risk usually lies in the ground’

The ground is a vital element of all structures which rest on it or in it, and there is no other element about which less is known.’

‘Insufficient attention is given to desk studies to provide valuable information at low cost’

(from: Report of the Site Investigation Steering Group of the Institution of Civil Engineers on *Site Investigation in Construction, Volume 1, Without Site Investigation Ground is a Hazard*. Thomas Telford, London 1994.)

CONTENTS

1 Introduction	1
1.1 Background to report	1
1.2 Methodology	1
2 Geological framework	2
2.1 Stratigraphic setting	2
2.2 Lithological characteristics	3
2.3 Depositional environment	4
3 Mineralogical considerations	6
3.1 Non-clay minerals	6
3.2 Clay minerals	6
3.3 Regional variation	6
3.4 Diagenesis and weathering	8
4 Geophysical correlation	10
4.1 Regional geophysical correlations	10
4.2 Well-log correlations	11
5 Geotechnical database	12
5.1 Data sources	12
5.2 Database structure	12
5.3 Data validation	12
5.4 Data analysis	12
5.4.1 Statistical values	12
5.4.2 Box plots	13
5.4.3 Extended box plots	14
6 Geotechnical properties	15
6.1 Parameter range and their variation	15
6.2 Depth profiles	19
6.3 Parameter correlations	21
6.4 Summation	21
7 Groundwater considerations	38
7.1 Porosity and permeability	38
7.2 Permeability heterogeneity	39
7.3 Pore water chemistry	39
7.4 Role in the regional hydrogeological regime	40
8 Implications for land-use and engineering construction	41
8.1 Slope stability	41
8.1.1 Causes of shallow landslides	41
8.1.2 Shallow slope instability	43
8.1.3 Major deep-seated landslides	44
8.1.4 Implications for land-use and construction	44
8.2 Foundations	44
8.2.1 Shrinking and swelling	44
8.2.2 Chemical attack on buried concrete	45
8.3 Earthworks	46
8.3.1 Excavations	46
8.3.2 Cuttings and embankments	47
8.4 Site investigation procedures	48
9 Conclusions	49
References and bibliography	53
Project reports	57
Appendix 1	58
Regional geophysical borehole log correlations	58
Boreholes used for geological/geophysical correlation	59

FIGURES

2.1 Outcrop of the Gault and Upper Greensand	2
2.2 Idealised rhythmic sedimentary unit (after Gallois and Morter, 1982)	4
3.1 Liquid and plastic limit of the Upper and Lower Gault with the dominant clay minerals present	7
3.2 Fence diagram of the Gault clay/Upper Greensand of southern England showing regional variations in thickness and mineral assemblages (Jeans, 1978)	8
5.1 The areas used for statistical examination of regional variation in geotechnical properties	13
6.1 Box and Whisker plot: Bulk density, γ_b (Mg/m ³)	23
6.2 Box and Whisker plot: Dry density, γ_d (Mg/m ³)	23
6.3 Box and Whisker plot: Moisture content, w (%)	23
6.4 Box and Whisker plot: Liquid limit, LL (%)	23
6.5 Box and Whisker plot: Plastic limit, PL (%)	24
6.6 Box and Whisker plot: Plasticity index, PI (%)	24
6.7 Envelope plot: Particle size grading (all data)	25
6.8 Box and Whisker plot: Total sulphate, TS (%)	24
6.9 Box and Whisker plot: pH	24
6.10 Box and Whisker plot: Total cohesion, c_u (kPa)	26
6.11 Box and Whisker plot: Effective cohesion, c' (kPa)	26
6.12 Box and Whisker plot: Effective friction angle, ϕ' (degrees)	26
6.13 Scatter plot: Effective shear strength vs. Depth (Triaxial — all data)	27
6.14 Line plot: Natural moisture content, w (%) v Depth (m)	27
6.15 Line plot: Liquid limit, Plastic limit, natural moisture content, w (%) v. Depth (Arlesey and Klondyke)	28
6.16 Line plot: Bulk density, γ_b (Mg/m ³) v Depth (m)	28
6.17 Scatter plot: Total cohesion vs. Depth (Triaxial — all data)	29
6.18 Scatter plot: Total shear strength vs. Depth (Triaxial — all data)	29
6.19 Envelope plot: Total cohesion vs. Depth (by Area)	30
6.20 Scatter plot: Bulk density, measured vs. calculated (from moisture content)	31
6.21 Casagrande 'plasticity' plot (all data except Harwell)	32
6.22 Casagrande 'plasticity' plot — area envelopes (all data except Harwell)	33
6.23 Casagrande 'plasticity' plot (all data)	34
6.24 Skempton 'activity' plot (all data)	35
6.25 Scatter plot: Carbonate content vs. Liquid limit (Arlesey, Klondyke Farm and Harwell)	36
6.26 Scatter plot: Effective residual friction angle vs. Plasticity index (All)	37
6.27 Scatter plot: Effective residual friction angle vs. per cent Clay size (All)	37
8.1 A plot of plasticity index and whole rock smectite content for samples from boreholes at Arlesey, Klondyke and Shaftesbury	42

- 8.2 A plot of liquid limit and whole rock smectite content for samples from boreholes at Arlesey, Klondyke and Shaftesbury 42
- 8.3 A plot of Atterberg limits with whole sample smectite content and clay mineral assemblage for samples from the Arlesey borehole 43

PLATES

- 1 Arlesey pit. The Chalk is exposed at the top of the pit resting unconformably on the Gault clay 3
- 2 Selbourne Brickworks. Weathered, desiccated highly fissured Gault clay with water flowing through the oxidised fissures 20
- 3 Arlesey Brickpit. Fresh Gault clay showing concoidal fracture and much less fissuring than the weathered material shown in Plate 2 20
- 4 Cutting in Gault clay on the route of the M40 Motorway where a slide has occurred on a discontinuity in the clay which is dipping out of the face at a high angle. The face is capped by a thin layer of gravelly sand 46
- 5 Arlesey Brickpit. Remoulded wet Gault clay in the pit floor causing poor trafficability 47

TABLES

- 2.1 Generalised Albian zonal scheme 3
- 5.1 Relationship between size of dataset and number of subsidiary percentile boxes shown 14
- 6.1 Arithmetic means of the basic index parameters for each Area 15
- 6.2 Classification of soil for precautions against sulphate attack on buried concrete based on total sulphate content 16
- 6.3 Arithmetic means and medians for chemical test results 16
- 6.4 Arlesey and Klondyke Farm — oedometer and triaxial test summary data 17
- 6.5 Arithmetic means for the triaxial strength parameters of each Area 17
- 6.6 Arlesey, Klondyke Farm, and Shaftesbury — residual strength test summary data 18
- 6.7 Boreholes in the geotechnical database greater than 30 m depth 19

DIRECTOR'S PREFACE

Since its inception in 1967, the Engineering Geology and Geophysics Group has been responsible for providing information on the physical properties of rocks and sediments to a wide range of BGS activities both on land and at sea. The Group has maintained a laboratory facility over this period and has carried out a wide range of geotechnical and geophysical tests on core samples from boreholes, block samples from trenches, and samples from rock exposures in the survey areas. All the data obtained have been collected and retained on a number of databases, which are now being brought together in one common format via specific studies on the various geological map sheets or general studies such as the Gault Clay Project described below.

Early work concentrated on the production of engineering geological maps and over the years a wide range of different types of maps have been produced both for BGS projects and specialised studies for the Department of Environment. These maps were developed with the associated database and often a table, in which the engineering properties of all the formations on the map were assessed from the point of view of civil engineering construction. This approach produced generalised geotechnical and geophysical appraisal of the geological formations concerned on the maps but did not examine the variability of these properties for a specific formation outside the area of interest. Hence, the present approach of studying a single formation in more detail over its total extent both vertically and laterally was considered and the Gault Clay Study described below is the first in this new series of geotechnical/geophysical studies.

Although it is not the intention to look at every geological formation in the UK the overall project is intended to study those formations which present serious engineering problems or on which significant areas of the built environment are founded. It is anticipated that the project

will take a number of years to characterise the necessary formations.

The study of the first formation has also been a search for the best methodology with which to achieve the desired end result. Therefore, the first study has evolved as it has progressed. Its scope and emphasis has changed and its timescale has been longer than that envisaged for most of the formations still to be studied. It became apparent during the initial stages of the project that in order to study and understand the variation in engineering behaviour shown by a formation the geophysical properties should also be considered and that geophysical borehole log correlation could assist in the interpretation of regional variation in engineering behaviour. The scope of the project was therefore expanded to include the geophysical properties of formations and their regional correlation.

The Gault clay project thanks the many people who have helped in the course of this study, especially the civil engineering industry whose contractors, consultants and their clients have donated or made available geotechnical information which has been central to the study. Thanks are also due to the many staff of the British Geological Survey, not named in the report as coauthors, who have contributed in many ways to the success of the project.

Peter J Cook, DSc

Director

British Geological Survey

Keyworth

Nottingham

June 1995

EXECUTIVE SUMMARY

The Gault is a sequence of clays, mudstones and thin siltstones with bands of phosphatic nodules of Middle and Upper Albian age. Its outcrop stretches south-westward from East Anglia through Wessex to west Dorset and surrounds the Weald in an arc from North East Kent westwards through Surrey to Hampshire where it turns south and returns eastward through west and east Sussex. The Gault clay thickens to the south and reaches its maximum development of over 100 m in the Weald and thins to the west as it passes into Hampshire and Dorset.

The Gault clay contains both clay and non-clay minerals. The major non-clay minerals are quartz and calcite. Quartz usually makes up about 20% or more of the Gault and its distribution is fairly uniform. Calcite is present as fossil debris and as a cementing agent. The Gault is more calcareous in the north east than the south and west.

The major clay minerals present are kaolinite, illite and smectite. Two main clay mineral assemblages have been identified 'Kaolinite-illite' and 'Smectite-illite'. Higher concentrations of smectite have been found in fissures and in the zones around shear surfaces in landslips.

A geotechnical database for Gault clay was compiled from site investigations for major road developments and smaller local developments. The data were divided into eight geographical areas to study regional variation in geotechnical properties.

The study of the geotechnical properties in the database has shown that regional variations in geotechnical properties exist. These variations appear to be largely a function of depositional environment, lithology and stress history. Individual borehole records of the geotechnical index parameters generally show little variation with depth where the Gault is at outcrop, except near to the surface. However, greater variation is shown at subcrop and at depth.

Gault clay causes a number of serious geotechnical problems. Ancient and recent landslides have been recognised throughout the outcrop of the Gault clay and in some areas mapped. Most movement is of shallow translational type with rotational elements at the back scarp and flows at the toe region. Multiple retrogressive rotational failures occur on some slopes. Where Gault clay is part of a major, inland escarpment or coastal cliff, large, deep seated, landslide complexes have developed as at Folkestone Warren near Dover and at Ventnor on the Isle of Wight. Char-

acteristic slope angles measured in the field, used with geotechnical laboratory test data, can establish the maximum angle for long term stable slopes.

Gault clay contains significant amounts of smectite clays in parts of its sequence. In the south-west, where the Gault becomes siltier and more sandy, it is only of medium to high expansive potential; the remainder of the outcrop falls almost entirely in the very high expansive potential category. If foundations are placed at too shallow depth on such a material seasonal shrinking and swelling may result in damage to the building. Trees, shrubs or hedges may cause desiccation and damage if planted too close to a building or lead to swelling if they are removed prior to construction.

Gault clay may contain aqueous solutions of sulphate and sulphuric acid in the ground in sufficient quantity for potential chemical attack on concrete. The rate of attack is very much influenced by the permeability of the concrete and the position of the groundwater table.

Gault clay may be expected to be classed as medium to hard with respect to its diggability but the sides of the excavation itself may be unstable during and after excavation. The inflow of water into an excavation in Gault clay may soften the clay making traffic movement difficult or impossible for wheeled vehicles and may cause soft patches in the sub foundation clay which might require removal before foundation placement.

The recommended maximum slope angles for cuttings and embankments in order to restrict the failures to less than 1% within 22 years of construction are between 1:3.5 and 1:5 depending on the slope height.

The design of a site investigation should be preceded by a desk study and walk over survey. In areas which include sloping ground it is important to look at slopes both in and outside the site in order to ascertain their stability. The use of cable percussion drilling and sampling may not prove effective other than for disturbed samples. Modern rotary coring techniques offer good quality samples but may encounter problems with swelling. Near-surface, the use of trial pits has significant advantages over percussive or rotary drilling. When working in weak, sheared, disturbed material, such as soliflucted and cryoturbated Gault clay, it is essential that safety procedures are observed and suitable support is installed to maintain the safe standing of the pit walls during logging and sampling.

1 Introduction

1.1 BACKGROUND TO REPORT

The Gault clay of England is a clay formation which causes a number of serious geotechnical problems and exerts a significant influence on land-use and the construction of transportation routes. Its properties are such that it may cause structural damage to buildings, due to shrinking and swelling under the influence of moisture content variation. This is a problem which has caused considerable financial loss during the protracted droughts of recent years. The Gault outcrop is also frequently associated with landsliding on both large and small scale.

This report on the Gault clay is one of a series on the rocks and soils of Great Britain which aims to satisfy a need of geologists and engineers for reference works describing the engineering behaviour of important geological formations present in the British landmass.

1.2 METHODOLOGY

The properties and behaviour of geological materials are not solely the result of their component minerals. Their texture, which is a reflection of their depositional environment, diagenesis and subsequent tectonic history also have a major influence on the current engineering behaviour of the formation as a whole. Also, the near-surface zone has been influenced by earth surface processes acting recently. In many instances the behaviour of the material cannot be predicted unless the recent geological history of the site is understood.

The Gault clay study comprised three phases. Initially, earth-surface processes were studied, then a detailed examination of the geotechnical properties of the Gault clay core from two research boreholes was carried out and lastly the regional variation in lithological character, geotechnical properties and engineering behaviour was reviewed using an extensive geotechnical database

assembled from site investigation reports. The first phase of the project addressed the influence of earth-surface processes on the behaviour of the Gault clay and its interaction with adjacent formations, the Upper and Lower Greensand. The relationship between the Gault clay and the Upper Greensand, with regard to landsliding, hydrogeology and glacial history, was examined, in particular, at sites near Shaftesbury (Dorset) and Sherborne (Hampshire). In the course of this work four boreholes were drilled at Church Farm, Shaftesbury [ST 8650 2230], to give lithological and geotechnical information which would assist in the interpretation of the landslide processes. These data were added to in the second phase of the project in which two research, cored boreholes were drilled at Arlesey, Bedfordshire [TL 1887 3463] and Klondyke Farm, Cambridgeshire [TL 5940 7010]. The latter holes were logged with wire line geophysical tools to give in-situ information. The cores were logged using geological, geophysical and engineering geological methods and subjected to close sampling for very detailed geotechnical and mineralogical examination.

The regional study of geotechnical properties and engineering behaviour was based on a collection of geotechnical data from published papers, site investigation reports and laboratory reports. Much of these data were obtained from local authorities, geotechnical engineering consultants and contractors. The data collected were used to compile two databases: (a) a geotechnical database which would be used for studying regional variation and subsequently incorporated into the BGS National Geotechnical Database and (b) a geophysical database of geophysical logs of boreholes drilled into, and through, the Gault clay was assembled from as many sites as possible. This enabled a detailed correlation of the geophysical and biostratigraphical divisions of the Gault clay and adjacent formations to be carried out. This provided the framework within which the regional variation of geotechnical properties was reviewed.

2 Geological framework

2.1 STRATIGRAPHIC SETTING

The Gault outcrop stretches south-westward from East Anglia through Wessex to west Dorset and surrounds the Weald in an arc from north-east Kent westwards through Surrey to Hampshire where it turns south and returns to an eastward strike through west and east Sussex. Outcrops are also present on the Isle of Wight Figure (2.1). It is an argillaceous formation within a group of sediments which comprise the Albian Stage and form the upper part of the Lower Greensand (Aptian) and the base of the Chalk (Cenomanian) (Table 2.1). Depending on the geographical location, the base of the Chalk is taken as the base of the Glauconite Marl (the Chloritic Marl of older texts e.g. Jukes-Brown, 1900) or the base of the Cambridge Greensand. This dual definition of the boundary depends on the presence or absence of the Upper Greensand which

overlies the Gault to the south and south-west of southern Bedfordshire. The Glauconite Marl occurs as a variable sandy argillaceous chalk with a varying glauconite and quartz content. The upper surface of the Albian, on which the Glauconite Marl rests, is eroded, often phosphatised, pitted and polished. Although, in the south and west of England, the Cambridge Greensand occupies the same stratigraphic position as the Glauconite Marl and occurs as a glauconitic silty marl with phosphatic pebbles, it cannot be assumed to be directly correlatable. The age difference of these basal Cenomanian deposits is indicated by the contained indigenous and *remanie* faunas.

The base of the Albian is less easily defined. The bulk of the Lower Greensand lies within the underlying Aptian Stage, but faunal zonation evidence shows that the Carstone, which occurs primarily in East Anglia and the Isle of Wight, and part of the Folkestone Beds (Kent/Sussex) form the basal beds of the Albian. These beds

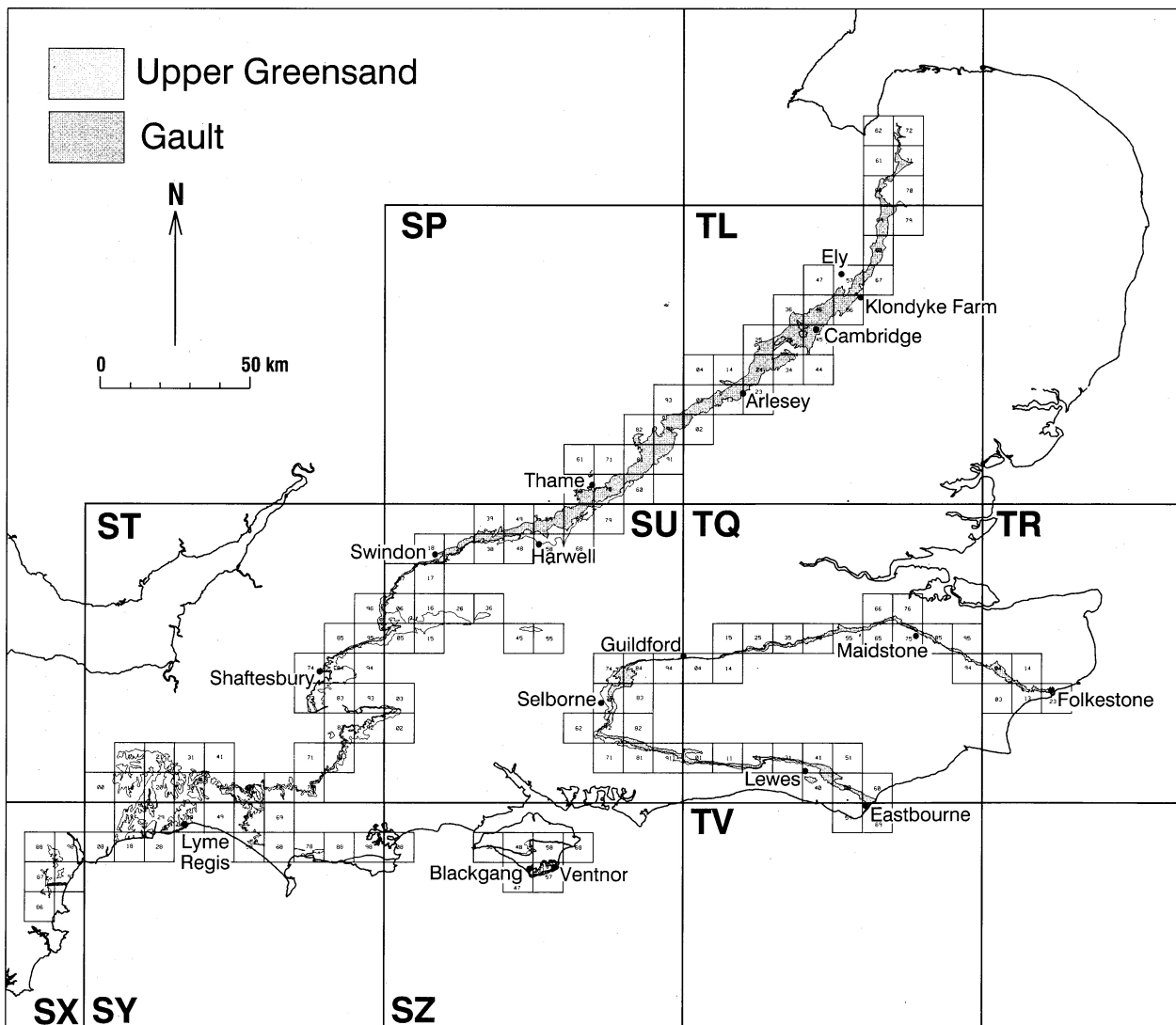

Figure 2.1 Outcrop of the Gault and Upper Greensand.

Table 2.1 Generalised Albian zonal scheme.

STAGE*	ZONE	FORMATION*
CENOMANIAN (pars)	<i>Mantelliceras mantelli</i>	LOWER CHALK
UPPER ALBIAN	<i>Stoliczkaia dispar</i> <i>Mortoniceras inflatum</i>	UPPER GREENSAND CAMBRIDGE GREENSAND GLAUCONITE MARL
MIDDLE ALBIAN	<i>Euhoplites lautus</i> <i>Euhoplites lorricatus</i> <i>Hoplites dentatus</i>	GAULT
LOWER ALBIAN	<i>Douvilleiceras mammillatum</i> <i>Leymeriella tardefurcata</i>	'CARSTONE'
APTIAN (pars)	<i>Parahoplites nutfieldensis</i>	LOWER GREENSAND

(based on Gallois, 1988 Ely memoir)

* DEFINITIONS

1. STAGE: the basic unit in chronostratigraphy
2. FORMATION: the basic unit in lithostratigraphy and can be defined as the smallest mappable unit (scale dependant) and exhibits a distinct lithology as compared with those above and below. The boundaries may be fixed where sharp or randomly placed in a gradational sequence. A Formation can be subdivided into:

MEMBER: for a minor or less extensive lithological variation within the main sequence, e.g. sand lens

BED: each bed within the sequence

commonly comprise sandy clays with phosphatic nodules, exhibit an upward increase in clay content and pass gradationally into the mudstones of the Gault. The depositional environment indicates that they are more closely related to the Albian sediments above them than the Aptian sands below.

The boundary between the Lower and Middle Albian, i.e. between the basal arenites (Carstone) and argillites (Gault) has been placed at a level showing a change from predom-

antly arenaceous to argillaceous sediments which coincides with the top of the mammillatum Zone (Table 2.1).

The Gault and Upper Greensand, whilst being separate formations, occur as a lateral facies variation. The Gault clay in eastern Kent extends to the top of the Albian stage where the Upper Greensand is absent.

2.2 LITHOLOGICAL CHARACTERISTICS

Gault is the name given to the sequence of predominantly clay facies sediments within the Albian Stage of the Lower Cretaceous, which rests unconformably on older strata, and is itself overlain unconformably by the Chalk (Plate 1). Three major lithological units form the sequence, (Table 2.1).

(a) The Carstone (Lower Albian) is present at the base of the sequence in East Anglia and southward through the Weald to the Isle of Wight. It is an arenaceous facies which together with older sands forms the Lower Greensand (in a broad definition). It is up to 18 m thick, and passes gradationally upwards to the Gault clay.

(b) The Gault (Middle and Upper Albian), is a sequence of clays, mudstones and thin siltstones with variable bands of phosphatic nodules. In East Anglia and East Kent, the Gault extends upwards to include sediments of Upper Albian age. In the northern part of East Anglia the clays are replaced by the Red Chalk, a carbonate facies equivalent to the Middle and Upper Albian elsewhere, which reaches a maximum thickness of approximately 2 m. The Gault thickens to the south and reaches its maximum development of over 100 m in the Weald. This clay facies thins to the west as it passes into Hampshire and Dorset, the upper zones being replaced by sand and chert of the Upper Greensand. In the Penn Cross Borehole in west Dorset the clay facies has a thickness of only 1.9 m (Anon, 1974).

(c) The Upper Albian of Wessex and the western Weald shows the development of beds of sand and chert of the

Plate 1 Arlesey Pit. The Chalk is exposed at the top of the pit resting unconformably on the Gault clay.



Figure 2.2 Idealised rhythmic sedimentary unit (after Gallois and Morter, 1982).

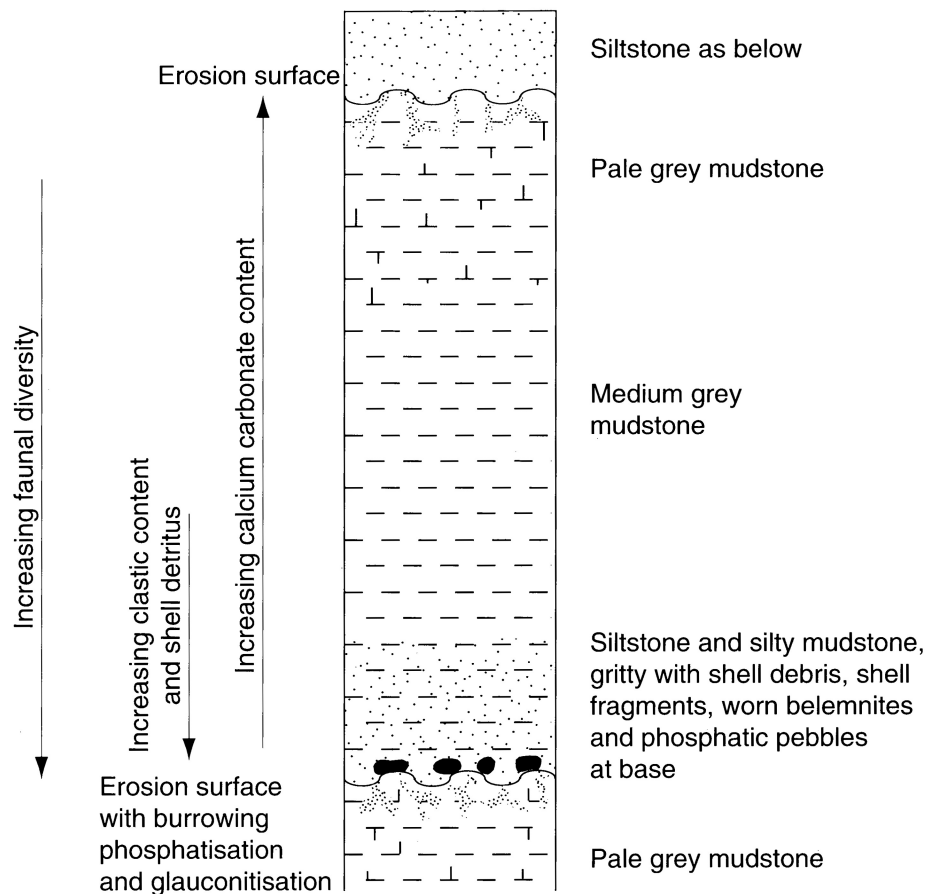

Upper Greensand, which both thicken and overstep the Gault to the west.

The Gault can be divided into two parts on the basis of lithology, the Lower and the Upper. The Lower consists mainly of medium and dark grey, soft mudstones and silty mudstones, with illite and kaolinite the predominant clay minerals. The Upper division is paler, has a higher calcium carbonate content, and smectite is the dominant clay mineral group. In general, the Upper Gault is thicker than the Lower and a faster deposition rate has been suggested.

The Lower Gault, and lower part of the Upper Gault comprise a number of thin (1–2 m maximum) rhythmic sedimentary units. At the base, these units are marked by a burrowed, phosphatised glauconite-rich erosion surface; the lower sections are shell-fragmental siltstones or silty mudstones with worn belemnites and phosphatic pebbles (nodules) which indicate a depositional hiatus associated with a break in the supply of terrigenous material. These, in turn, are gradationally overlain by medium grey mudstones which pass upwards to pale grey mudstones to complete the cycle (Figure 2.2).

It has been suggested that a large proportion of the Gault time span is represented by periods of non-deposition (Gallois, personal communication). It has also been suggested that the phosphate nodules were formed by colloidal aggregation about a 'seed' nucleus during periods of winnowing of loose unconsolidated argillaceous material (Merriman, personal communication). Sulphide accessory minerals are not uncommon which suggests an anaerobic environment. The basal beds of the Albian in Kent are, locally, up to 300 mm in thickness and are named the Sulphur Beds, an allusion to the large quantities of

massive iron pyrites mixed with phosphatic nodules which they contain.

2.3 DEPOSITIONAL ENVIRONMENT

In general, the whole of the Lower Cretaceous of southern and south eastern England indicates a marine transgression from the coastal lagoonal and deltaic deposits of the Lower Greensand (*sensu lato*, Aptian and Albian stages) to the marine offshore sequences of the Middle and Upper Albian, the Gault and Upper Greensand. This transgression can be demonstrated to have progressed westwards from the south-east because the base of the Gault is unconformable on increasingly older strata towards the west and faunal zones at the base of the Gault become younger in that direction. In the Weald, East Anglia and parts of Wessex where the Carstone is present below the clays, the base of the Carstone can be shown to mark the position of the unconformity. However, this is not obvious as there is no distinct angular discontinuity between the Albian and Aptian sediments below.

The continued submergence of land masses during the later Albian resulted in later units of the Gault lying directly on the Palaeozoic basement of the Anglo-Brabant Massif; rapid local variations in the age of the base of the Gault over this structural high suggests the submergence was associated with penecontemporaneous block faulting which affected the deposition of the Gault (Owen, 1971). Elsewhere, notably in Dorset, intra-Cretaceous tectonic movements resulted in the faulted periclinal structures around Weymouth, together with less severe structures in the Vale of Wardour. In eastern Dorset the base of the

Gault rests on sediments of Lower Kimmeridgian age and this suggests the removal, prior to the deposition of the Gault, of the order of 1200 m of sediments (Hancock, 1969). Drummond (1970) suggests a series of faults and folds with a Charnoid trend extend across central Dorset (the 'Mid-Dorset Swell') which affected the deposition of Upper Albian sediments (also the succeeding Cenomanian) with local erosion and condensed sequences of *inflatum* and *dispar* zone arenites across the axis.

In the northern part of East Anglia, passing into Lincolnshire and Yorkshire, the clay facies passes laterally into the carbonates of the Red Chalk. Fossil remains of algal stromatolitic mats found in these carbonates indicate that they were probably deposited under shallow water or intertidal conditions because analogous present day forms are developed only in the photic zone.

A lateral facies change in the Upper Albian occurred westwards from the Central Weald and resulted in the formation of a laterally variable sequence of arenaceous sediments, the Upper Greensand. This is considered to be a proximal onshore or coastal shallows deposit. It reaches its maximum thickness in western Wessex and, where the Gault is absent to the west of Lyme Bay, it replaces the Gault as the oldest Albian formation. The Upper Greensand outcrop continues westward overstepping progressively older strata, until in the western limits, to the east of Dartmoor in the Haldon Hills, *inflatum* zone sediments of

Upper Albian age rest on Permian deposits (Hamblin 1968, 1972).

The presence of glauconitic sands of the Upper Greensand above the Gault which extend as far east as Sevenoaks in the Weald and into southern Bedfordshire, has been interpreted as a prograding to the east of the shoreline conditions and possibly represents a minor regressive phase (Sellwood and Sladen, 1981). This eastward regression of the Upper Greensand is supported by lateral variation in the stratigraphic position of chert beds in the Upper Greensand of Wessex. Tresise (1961) demonstrates that the relative age of chert beds is younger in the eastern Wessex Basin than in the west on the premise that the development of chert requires a low energy environment. As onshore conditions regressed eastward so the conditions for the chert development regressed ahead of the high energy environment sands. Tresise (1961) suggests that the Upper Greensand chert had been formed by the precipitation of colloidal silica on the sea bed and that the resultant siliceous sinter was later converted to chert by the deposition of silica from solution the secondary silica having been derived from the exsolution of opaline silica from sponge spicules.

A sequence of passage beds occurs between the Gault and the Upper Greensand where the clays pass up into sands. These transitional beds occur primarily in the Wessex basin and are locally several metres in thickness.

3 Mineralogical considerations

3.1 NON-CLAY MINERALS

The Gault contains both clay and non-clay minerals. In studies of the Gault, as with most predominantly argillaceous sediments, most attention has been concentrated on the nature and distribution of the clay minerals and, thus, there is little information on non-clay mineral species within the clayey facies (Shaw, 1981). The major non-clay minerals are quartz and calcite. Quartz usually comprises about 20% or more of the Gault and its distribution is fairly uniform. Calcite is present largely as macrofossils, (mainly shell fragments) and micro fossils (mainly coccoliths). The Upper Gault tends to be more calcareous than the Lower Gault and the Gault in the north-east tends to be more calcareous than to the south and west. Recrystallised calcite may act as a cementing agent. Other non-clay minerals present are feldspar, mica, pyrite and, near to the surface, gypsum. In the near-surface zone calcite may be converted to gypsum by its reaction with acidic groundwater produced by the oxidation of pyrite during weathering. Two authigenic minerals, clinoptilolite and opal-CT, are found in the upper part of the Upper Gault at Harwell and may also act, locally, as cementing agents (Milodowski et al., 1982).

3.2 CLAY MINERALS

The clay minerals present in the Gault are predominantly kaolinite, illite (<2 μm mica), and smectite. Also present are vermiculite, chlorite and mixed layer clays. The distribution of these minerals within the formation is neither uniform nor random but occurs as a small number of identifiable associations or assemblages. The mineral composition of a soil or rock and its variation have an important bearing on the geotechnical behaviour. This is shown by, for example, the relationship between stratigraphy, bulk mineralogy, plastic limit and liquid limit for samples of Gault clay from Harwell Boreholes 3 (SU 46801 86441) and 4 (SU 46808 86440) (Figure 3.1) (Horseman et al., 1982; Gallois and Worssam, 1983; Wilmot and Morgan, 1982; Milodowski et al., 1982). The upper part of the Upper Gault exhibits very high liquid limits (>90%) within the smectite-dominated zone. Clays with high smectite content show high plasticity with low strength and are likely to undergo significant volume change with moisture content variation, have high swelling pressures, low angles of internal resistance and low residual strength. High smectite content can be inferred from the high surface area of the clay mineral component and the extremely high liquid limit results. The smectite content, determined by surface area measurement, is a useful guide to geotechnical behaviour and may be used in conjunction with X-ray diffraction analysis to indicate the clay species present.

An understanding of the geological origin and mode of deposition of the high smectite clays, together with other clay mineral analyses, can give a model of their regional distribution which can be used as a guide to predict geotechnical behaviour. A detailed account of the results of the

mineralogical work done during this study is given by Entwisle (1994).

3.3 REGIONAL VARIATION

A fence diagram based on the results of analyses of material from boreholes, pits and natural exposures (Jeans, 1978; Jeans et al., 1982) (Figure 3.2) shows that the Gault can be split into two major divisions on the basis of its clay mineral composition: a kaolinite-illite dominated assemblage and a smectite-illite dominated assemblage.

The kaolinite-illite assemblage is characterised by large amounts of kaolinite and illite with variable amounts of vermiculite and mixed-layer phases, such as smectite-illite, smectite-vermiculite and vermiculite-illite. The smectite-illite assemblage is characterised by smectite and/or irregular mixed-layer smectite-mica as a major phase where illite may be the major or minor component; kaolinite is absent or present only in minor or trace amounts (Jeans et al., 1982). Three sub-assemblages within the smectite-illite assemblage have been recognised: (i) smectite-illite (S-I), (ii) smectite-illite-quartz (S-I-Q), (iii) smectite-illite-quartz-opal-CT-zeolite (S-I-Q-O-Z). Each sub-assemblage has a characteristic distribution. S-I is restricted to clay-grade facies and clay lenses within sand facies and S-I-Q and S-I-Q-O-Z are found in sand-grade and silt-grade facies, (mainly the Upper Greensand).

Around the margins of the London Platform at Folkestone, Warlingham and Leighton Buzzard, thick, localised, lenticular, clay bodies of the S-I sub-assemblages are found at the base of the Gault. They contain fresh sand-grade volcanoclastic grains which include unabraded, 'glassy, pumice particles, sanidine fragments, apatite and rutile needles. The S-I sub-assemblage is also present in the upper part of the Gault where it occurs in clay units below the base of the Upper Greensand. Jeans (1978) found that the Upper Greensand was characterised by S-I-Q and S-I-Q-O-Z. Jeans et al. (1982), reported that the smectite-illite-quartz-opal-zeolite assemblage in Upper Albian sequences is only found in the Upper Greensand and is always separated from a kaolinite-illite assemblage by the smectite-illite assemblage. However, Wilmot and Morgan (1982) and Milodowski et al. (1982) showed that the S-I-Q-O-Z sub-assemblage was also found in the upper part of the Gault at Harwell, with the smectite-mica zone between the S-M-O-Q-Z and the kaolinite-mica assemblage.

The smectite-mica clays of the upper part of the Gault are not usually associated with sand-grade volcanoclastics, although pumice and sanidine grains have been found in the Upper Gault at Folkestone (Jeans et al., 1982). However, they do have similar trace element patterns to the S-I clays at the base of the Gault at Folkestone, Warlingham and Leighton Buzzard. This suggests that smectite found in the Gault is of mainly volcanic origin. At the base of the Gault at Folkestone, Leighton Buzzard and Warlingham the smectite is a secondary bentonite, the result of post-depositional argillisation of localised current

Figure 3.1
Liquid and plastic limit of the Upper and Lower Gault with the dominant clay minerals present.

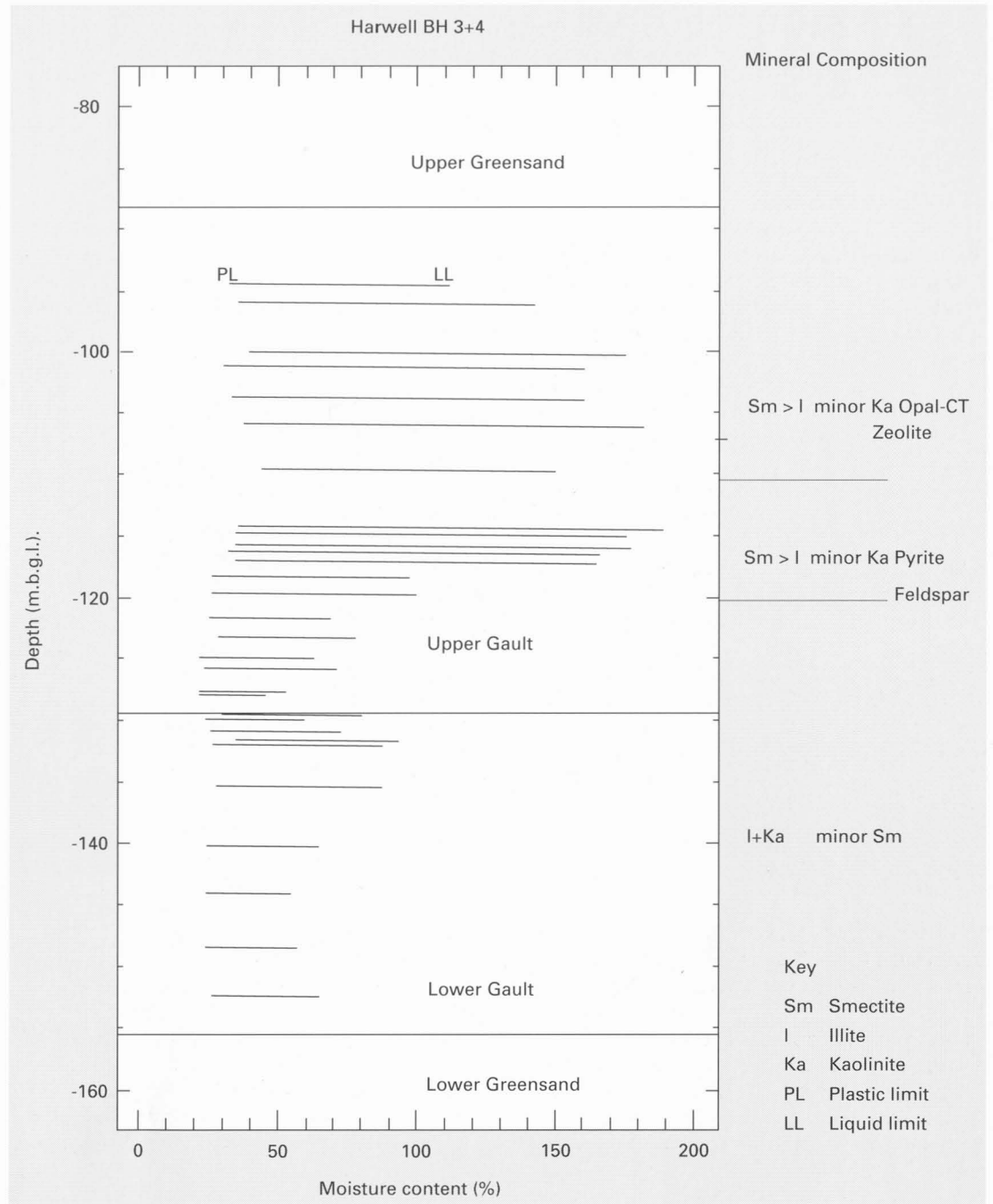

accumulations of volcanic ash transported into the marine environment by rivers draining from a nearby landmass. The secondary bentonite is typically altered, coarse-grained ash, commonly interbedded with near-shore sands and shows internal cross-lamination, which suggests rapid deposition from turbidity currents. It also occurs as finer-grade deposits, usually interbedded with non-volcanic, locally derived, terrigenous material which was deposited relatively slowly. Secondary bentonite occurs as lenticular deposits of limited lateral extent (hundreds of metres) which vary in thickness from about 0.01 m to 4 m. The smectite of the upper part of the Gault is derived from volcanic ash distributed throughout the sediment, mixed to varying degrees with terrigenous material, but it does not form major concentrations typical of direct, air fall, deposition of ash.

The kaolinite-mica assemblage is typically found in the lower part of the Gault (except as described above), around the Weald and west of Leighton Buzzard. The Gault in the

north east (Norfolk and Bedfordshire) contains only the kaolinite-mica assemblage. In the south and east of the Weald the Upper Greensand is missing and the smectite-illite assemblage is found above the kaolinite-illite assemblage. South of the Weald the smectite assemblage is at its greatest thickness in the Glyndebourne borehole where it is about 75 m thick. It then dips below the Upper Greensand and thins towards the west until it is replaced by the Upper Greensand in Devon.

The distribution of the clay mineral assemblages, described by Jeans (1978) and Jeans et al. (1982) has formation control but little stratigraphic control. It is possible that the smectite-mica clays represent the upper part of the Gault or that there is a difference in the distribution of clay minerals within the Gault of the same age. In Jeans et al. (1982) the biostratigraphic bed numbers are compared with the clay mineral assemblages using the section at Folkestone as an example. This approach has been extended by Entwisle (1994) using boreholes and

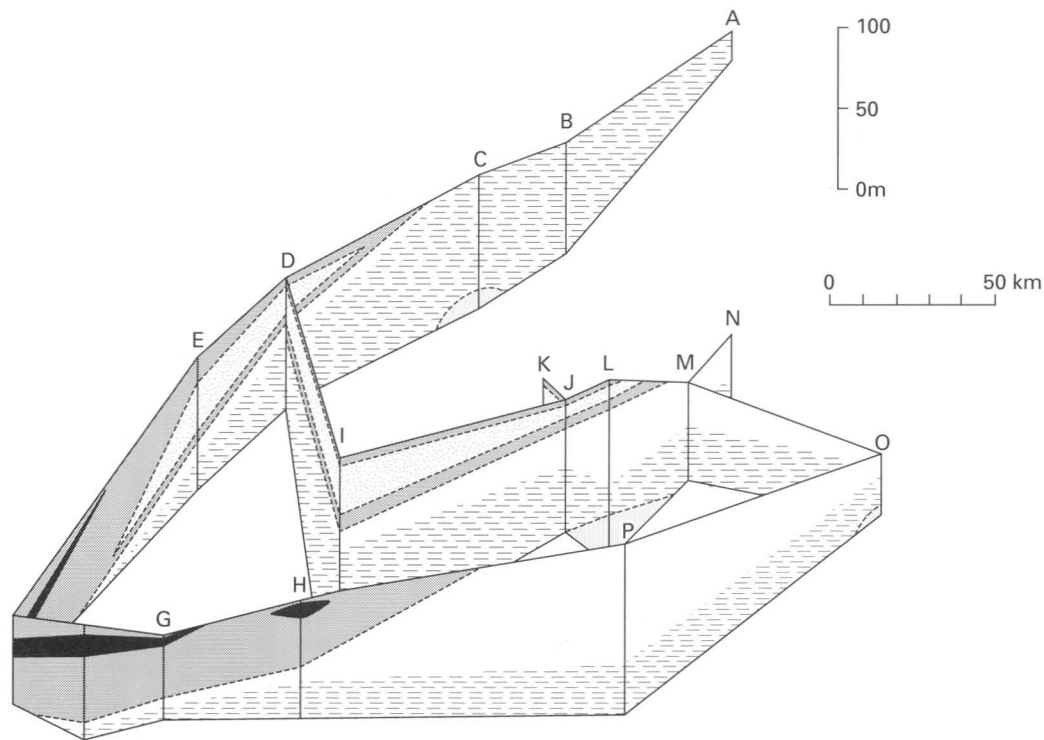
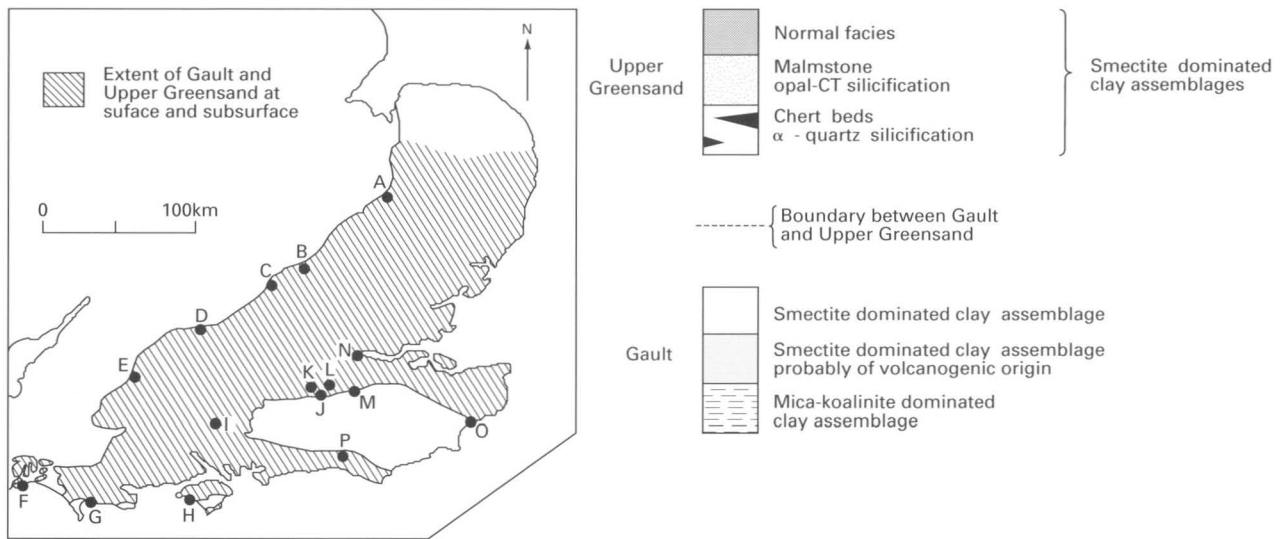

Figure 3.2 Fence diagram of the Gault clay/Upper Greensand of southern England showing regional variations in thickness and mineral assemblages (Jeans, 1978).

exposures for which the clay mineral assemblages and biostratigraphy have since become available.

3.4 DIAGENESIS AND WEATHERING

Most of the authigenic mineralisation and secondary porosity which have developed in the Gault clay appear to have formed at an early stage during the sediment's history. Opal-CT cemented clays, of the upper part of the Upper Gault at Harwell, have a relatively open, uncompacted fabric which suggests that the rock fabric was rigidly cemented by the precipitation of Opal-CT prior to significant burial and compaction. The apatite, seen in the lower

part of the sequence, is present as a cementing agent and is also interpreted as an early diagenetic change before significant compaction. In the more clay-rich samples from lower in the sequence many of the diagenetic voids have been crushed as a result of later compaction. Zeolite and smectite are seen coating opal-CT lepispheres (Milodowski et al., 1982). The diagenetic glauconite, and most pyrite, which occur as infills within microfossil cavities pre-date the development of diagenetic silica. The order of diagenetic changes is interpreted as follows:

- 1) Precipitation of pyrite and glauconite in reducing micro-environments within skeletal pore spaces. Glauconite formation requires aluminium, silicon, iron

and potassium. Silicon was supplied by the dissolution of biogenic silica, aluminium from amorphous aluminosilicate gels and fine volcanic dust; iron came from volcanic ash. Glauconite forms close to a water/sediment interface, at an aerobic/anaerobic boundary in slightly alkaline water, in conditions of low or negative sedimentation and is often associated with marine transgression. Favoured sites are found in foraminifer shells, filled with volcanic dust, and faecal pellets of volcanic dust which contain organic matter.

- 2) The formation of opal-CT, occurs after glauconite production at about 10 m or more below the water/sediment interface and occurs as follows;
 - i) Dissolution of biogenic silica to produce a secondary porosity.
 - ii) Precipitation of globules of amorphous silica and crystallisation to form opal-CT in the form of spherical aggregates of bladed crystals called lepispheres.
- 3) Precipitation of smectite and zeolite.
- 4) Recrystallisation of early-formed pyrite or, possibly, precipitation of secondary pyrite.
- 5) Compaction and minor deformation of the sediment fabric.

Some opal-CT in the Upper Gault occurs as linings on the walls of large diagenetic voids and some acts as a cementing agent. This was found to be the case during sample preparation for mineralogical determination, Wilmot and Morgan (1982) stated that 'In samples from the Upper Greensand and the uppermost Gault, complete dispersion could not be achieved using the ultrasonic probe; a number of hard, angular, blocky fragments remained which were cemented'. It was suggested that opal was the cementing agent. Mixed layer smectite/clay aggregates are also associated with opal-CT and zeolite.

In the Gault at Shaftesbury an anomalously high concentration of smectite was found in a very narrow band associated with a shear plane intersected by both Church Farm boreholes 1 and 2, (Bloodworth, 1990; Gostelow, 1991). An increase in smectite of 10–15% in the immediate vicinity of the shear plane was found in both boreholes. Each show a similar pattern of smectite content up to a metre either side of the shear plane. It has been suggested that the increase in the smectite content reflects the proportion of volcanic ash being deposited and may have been responsible for a lowered shear strength giving a predisposition for shearing along that horizon (Gostelow, 1991). However, the shear plane may cut different stratigraphical horizons in each borehole and it is possible that diagenetic changes along a zone of fluid flow may have been the cause of the increased smectite content. Smectite enrichment, in a zone 50–100 μm wide around fissures has been found in samples of Gault clay from the Klondyke borehole (Prior et al., 1993). It is likely that fissures or fractures, caused by stress relief, tectonic activity or mass movement may produce a narrow zone in which precipitation of smectite takes place producing a weaker zone. The zones are typically very narrow (μm to mm scale) and are unlikely to be detected by normal sampling methods but they may have a significant effect on slope stability.

The differences in the calcite and pyrite content between the two boreholes at Church Farm is attributed to the weathering of the near-surface material in borehole 2. The presence of gypsum in some samples in the upper part of borehole 2 suggests that oxidation of pyrite has taken place forming sulphuric acid which has reacted with calcium carbonate to produce secondary gypsum. The removal of calcite, if it is present as a cementing agent, will decrease the strength of the clay. The weathering processes does not appear to have affected the silicate component of the rocks to a significant degree.

4 Geophysical correlation

4.1 REGIONAL GEOPHYSICAL CORRELATIONS

Whilst there are a number of measured, detailed lithological and biostratigraphic sections of some parts of the Gault outcrop, there are few lithological correlations between the sites. A small number of cored boreholes penetrate the Albian and have been correlated with the outcrop sections using faunal zonation. However, a considerable number of non-cored boreholes penetrate the sequence and many of these have been geophysically logged, although few sites have a full biostratigraphic log.

Where boreholes do not penetrate the full sequence or have not been fully analysed to determine their biostratigraphic position it is not possible to place the geophysical logs in their correct stratigraphic position. This is further complicated in sequences lacking marker bands or those exhibiting lateral sediment variation. However, if sufficient coverage is available from other, fully penetrating boreholes in the region it is possible to assign the site to its appropriate stratigraphic position.

Borehole geophysical well-logs are a proven technique of long-distance lithological correlation and this method has been applied to the Albian, using the natural gamma logs (Appendix 1, Figure 1). Where possible, the correlations are based on data obtained from boreholes which have been both fully cored and geophysically logged (primarily those in East Anglia) with zonal or chronostratigraphic control, but elsewhere correlations shown in the figures are taken at levels of well-defined lithological variation.

Seventy-one hydrocarbon boreholes with natural gamma logs through the Albian have been identified within the BGS Wellog Database (Appendix 1). Among these 24 also have sonic logs, 16 neutron (porosity) logs, and 11 density logs. However, not all of these can be used for correlation purposes. Several of the older data sets in north-east Norfolk and in east Kent exhibit such poor definition that it is difficult to identify the Albian even where its position has been fixed from lithological logs of cuttings.

Without biozonal or palynological zonal evidence from cores or cutting samples it is not possible from the geophysical evidence alone to decide if variations between successive sites represent changes in the true formation thicknesses (i.e. true vertical thickness). Similarly, it is not possible to estimate the intersection angle between the borehole and the dip of the strata and it is not possible to ascertain if any sections have been faulted resulting in the absence or repetition of parts of the sequence. At only one site (Lomer, SU 5959 2356) are the effects of faulting obvious as illustrated by comparison of the Lomer and Horndean boreholes (Appendix 1, Figure 2). In this case, it appears that two faults are present which affect the Albian; the lower cuts out the majority of the Gault and possibly the lowest beds of the Upper Greensand, whilst the upper has removed approximately 15 m from the top of the Upper Greensand together with part of the Glauconite Marl (the basal Cenomanian is only half as thick as it is elsewhere).

Variations in the quality, and hence the usefulness, of gamma logs are attributable to:

- (a) Differences in logging tools such as variations in detector size; the larger detectors giving more detailed logs.
- (b) Variations in logging speeds; the slower the speed the more detailed is the log.
- (c) Variations in casing thickness. Each casing string attenuates the signal by approximately 30%. Therefore, the more casing strings which are present, the weaker will be the signal. An apparent drop in signal may occur where casing strings terminate within the sequence falsely implying the upper sections are more arenaceous than those below. For example the log from the borehole at Aston Tirrold (Appendix 1, Figure. 9) shows an apparent drop in gamma reading at 47 m within the Upper Gault section. This feature does not exist elsewhere and it is probable that the drop is associated with the termination of a surface casing string.
- (d) The age of the log. Older logs are less detailed and are of poorer quality than more recent ones, mainly as a result of advances in the design and sensitivity of logging tools and to data capture in digital form.
- (e) The original purpose of the borehole. Boreholes drilled specifically for stratigraphic research have more detailed logs than those for hydrocarbon exploration because it is uneconomic to log, in detail, formations which are not of interest for reservoir potential or source rock evaluation.

Further complications arise from the inconsistencies between the various bed/zonal classifications of the Albian used by the various workers. This is a serious problem for Gault correlation. However, whilst there is a general agreement as to the ammonite zone sequence in the Albian, different bed sequences have been erected for some areas. These sequences have not been inter-correlated by lithology. In the southern and western Weald 13 beds have been recognised based on those observed at the type section at Folkestone (Casey, 1961). However, in East Anglia, Gallois and Morter (1982) recognised 19 subdivisions based on rhythmic sedimentation sequences. A third lithostratigraphic classification has been applied to the Dorset/Hampshire area, where beds are classified according to those compiled by Lang (1914) for the Charmouth area and this has been applied to the Albian section of the core from the Winterbourne Kingston borehole.

The highly variable nature of the sediments have precluded long distance bed sequence comparison between locations for the Upper Greensand. Also, the general lack of faunas within these deposits has inhibited biozonal correlation, although some units are well represented. Where biozonal control has been established, for example for the Winterbourne Kingston borehole reported by Morter (1982), the data indicate that the Upper Greensand is contemporaneous with the Gault clay and supports the evidence for these being facies variations of comparable age. This is exemplified by the position of the boundary between the *dispar* and *inflatum* zones (beds 16/17 of Gallois and Morter, 1982) which in East Anglia are within the Upper Gault but at Winterborne Kingston occur in the higher sections of the Upper Greensand.

Correlation of natural gamma logs is based on comparison of the relative position, geometry and detailed characteristics of the positive/negative features (peaks/lows) on the logs. In sedimentary sequences long distance correlations are relatively straightforward. In a limestone or sandstone (i.e. low gamma) sequence, selected marker bands are commonly mudstone or shale horizons which show as higher gamma peaks and are readily recognisable (e.g. marl bands in the Chalk). Conversely within a predominantly clay sequence the marker bands are gamma lows corresponding to siltstone, sandstone or limestone horizons (e.g. cementstone bands in the Oxford Clay).

The Gault clay and Upper Greensand contain no well defined lithological marker bands of value for correlation. In the case of the Gault clay, comparisons are based on mineralogical variations within the clays, namely glauconitic and phosphatic nodule bands; both features show as positive gamma values, glauconite due to an increase in potassium content and phosphatic nodules due to their enrichment in uranium.

Glauconite is present, also, as amorphous colloidal granules, composed of an hydrated iron/potassium silicate of variable composition, and is particularly common at the base of both the Gault and the Chalk.

The phosphatic nodule bands frequently contain rolled, or fragmental, shell debris and represent erosion levels within the clay sequence. Sulphide accessory minerals are not uncommon which suggests an anaerobic environment. The basal beds of the Albian in Kent are, locally, up to 300 mm in thickness and are named the Sulphur Beds, an allusion to the large quantities of massive iron pyrites mixed with phosphate nodules that they contain.

The enrichment by uranium, which gives rise to high gamma peaks, is probably also associated with anaerobic conditions. Bacteria, in anaerobic conditions, act as catalysts for the exsolution of soluble uranyl salts which form a substitution series of calcium and uranium phosphates. The nodules are concentrated in troughs within each erosive cycle; the troughs can be likened to 'mega-ripples' with a wave-length of kilometric scale and amplitudes up to several metres. Nodule concentrations are lower on the intervening ridges. Therefore, the position of the gamma log peaks in a borehole and their strength will vary depending upon where

it penetrates the troughs and highs of successive erosion cycles in the sequence (Figure 2.2). Correlations are made more difficult when the borehole, or its logging, does not penetrate the full thickness of the Gault.

4.2 WELL-LOG CORRELATIONS

The location of the comparative sections for the Albian are shown in Appendix 1 (Figure 1), together with the locations of the selected boreholes which were used to compile the sections. Although transgressive, the base of the Gault clay is taken as the standard reference level throughout. Whereas the top of the clay facies/base Upper Greensand junction is not always present or clearly defined and the upper boundary of the Albian (i.e. base of the Chalk) has not always been logged, the base of the Gault clay is well defined throughout. Owing to the lack of biostratigraphic zonal details for the majority of the sites the general correlations are constructed for:

Top of the Albian
Top of the Gault (where Upper Greensand is present)
Base of the Gault

However, where local zonal details exist other correlations have been added and extrapolated as far as the log data permits. These are primarily on the East Anglian sections, (Appendix 1, Figures 3 and 4), where it has been possible to erect further correlations, based primarily on the work by Gallois and Morter (1982). These levels are:

Boundary between Beds 16/17
Boundary between Beds 15/16
Upper/Lower Gault junction

In general the top of the Albian section is marked, almost everywhere, by a large gamma peak corresponding to either the Cambridge Greensand or to the Glauconite Marl; whilst the base is marked by a further gamma peak at the level of the glauconitic basal phosphate nodule band of the Gault. The details for each of the comparative sections and individual site details are given in Appendix 1.

5 Geotechnical database

5.1 DATA SOURCES

The geotechnical database for the Gault has been compiled from approximately 50 reports, the majority of the data were taken from a relatively small number of investigations for major road developments. Such investigations provide an abundance of good quality data, often across the entire outcrop, or occasionally (as in the case of the M25 motorway) for a considerable distance along it. This main data source has been supplemented by the reports of investigations for smaller local developments, which have tended to be more variable in quality. Whilst these latter reports have improved the geographical data coverage, some significant gaps inevitably remain along the predominantly rural Gault outcrop.

5.2 DATABASE STRUCTURE

The relational database structure for the geotechnical data comprises eight data tables, at four hierarchical levels. Table 1, (Reports), includes general information applicable to each report. Table 2, (Boreholes), records the location, ground level and depths to the top and base of the Gault for each of 502 boreholes. The stratigraphy and lithology of the 2500 individual 'samples' or test points is recorded at the third level, in Table 3, (Samples and Descriptors). A 'sample' here refers, equally, to a specimen of soil or rock which was removed for testing or, a test point, that is; a position in a borehole at which an in situ test was carried out. At the fourth level are the five tables, 3a–3e, in which are recorded the numeric geotechnical data. Of these, Table 3a, (General and Index Properties), and Table 3c, (Soil Strength), comprise the majority of the data.

The geotechnical data have been grouped into eight geographical areas to examine whether variation in properties takes place laterally along the outcrop (Figure 5.1). The geographical division has been based on the nature of the actual data distribution, to ensure at least a modest amount of data in each for statistical analysis, rather than on geological criteria. Areas 1 to 3 cover the main outcrop from Wessex to Cambridgeshire. Areas 4 and 8 respectively cover the western and southern outcrops of the Wealden syncline. Given the abundance of available 'motorway' data, the central section of the northern outcrop has been divided into three areas, (5–7), to enable more localised trends in the geotechnical properties to be examined. The three BGS boreholes from which geotechnical data were obtained for the full Gault sequence (Arlesey, Klondyke and Harwell) are excluded and treated individually.

5.3 DATA VALIDATION

The various tests, for which the data were obtained, should have been carried out to the appropriate British Standard (or other recognised international standard). However, experimental and operator error may result in variation in results between one contractor and another, and between

one report and the next. The data, as compiled, will inevitably include some which are inaccurate to a greater or lesser degree, resulting in a greater spread of results than would probably be found within any one report. Whilst assessing the site investigation data prior to data banking, efforts were made to reject clearly erroneous test results.

Once the data entry had been completed, each field of numeric data was examined, as a whole and for each of the eight geographic areas. Any extreme values, high or low, were checked against the data source, and those which were obviously unrealistic for the Gault were deleted as being gross errors. Each of the data sets were then displayed as normal probability plots using statistical graphics software. Where the data are normally distributed, they will plot as a straight line. Some parameters, such as cohesion, will typically show an even curvature or skew when the data axis is arithmetic, but a straight line if the axis scaling is changed to logarithmic. Such data distributions are referred to as log-normal. Sinuous plots, with the shape of an 'S' or a reversed 'S', show that the data is more heavy or light tailed than a normal Gaussian distribution (kurtosis). In practice, most geotechnical parameters plot with a limited degree of curvature or inflection, and the lines become noticeably ragged with smaller data sets.

For data validation, the ends, rather than the general shape, of the plots were examined. Sudden flexures here, with one or more points clearly departing from the general shape of the plot, indicate that these values are anomalous and unlikely to come from the same population as the bulk of the data. Such data were also checked against the source, and deleted when no plausible explanation could be found for their unusual value. Although somewhat subjective, this validation procedure is quite rapid. A major benefit is that the graphical display enables possibly anomalous points to be seen in relation to the degree of consistency in the body of the data.

5.4 DATA ANALYSIS

5.4.1 Statistical values

The data have been 'validated', as above, only in the sense that gross errors and anomalous values have been deleted. It is inevitable that all data of this type will be potentially subject to several sources of error. An examination of the frequency distributions from the Gault and other formations has shown that any assumption of normal (Gaussian) or other mathematically simple distributions is rarely satisfactory for geotechnical parameters.

In these circumstances the conventional summary statistics, such as the mean, and standard deviation can be very misleading since they do not portray the more reliable bulk of the data. These parameters (together with the less often quoted skewness and kurtosis) are sensitive to atypical and possibly erroneous values which may be expected in a geotechnical database derived from a variety of sources.

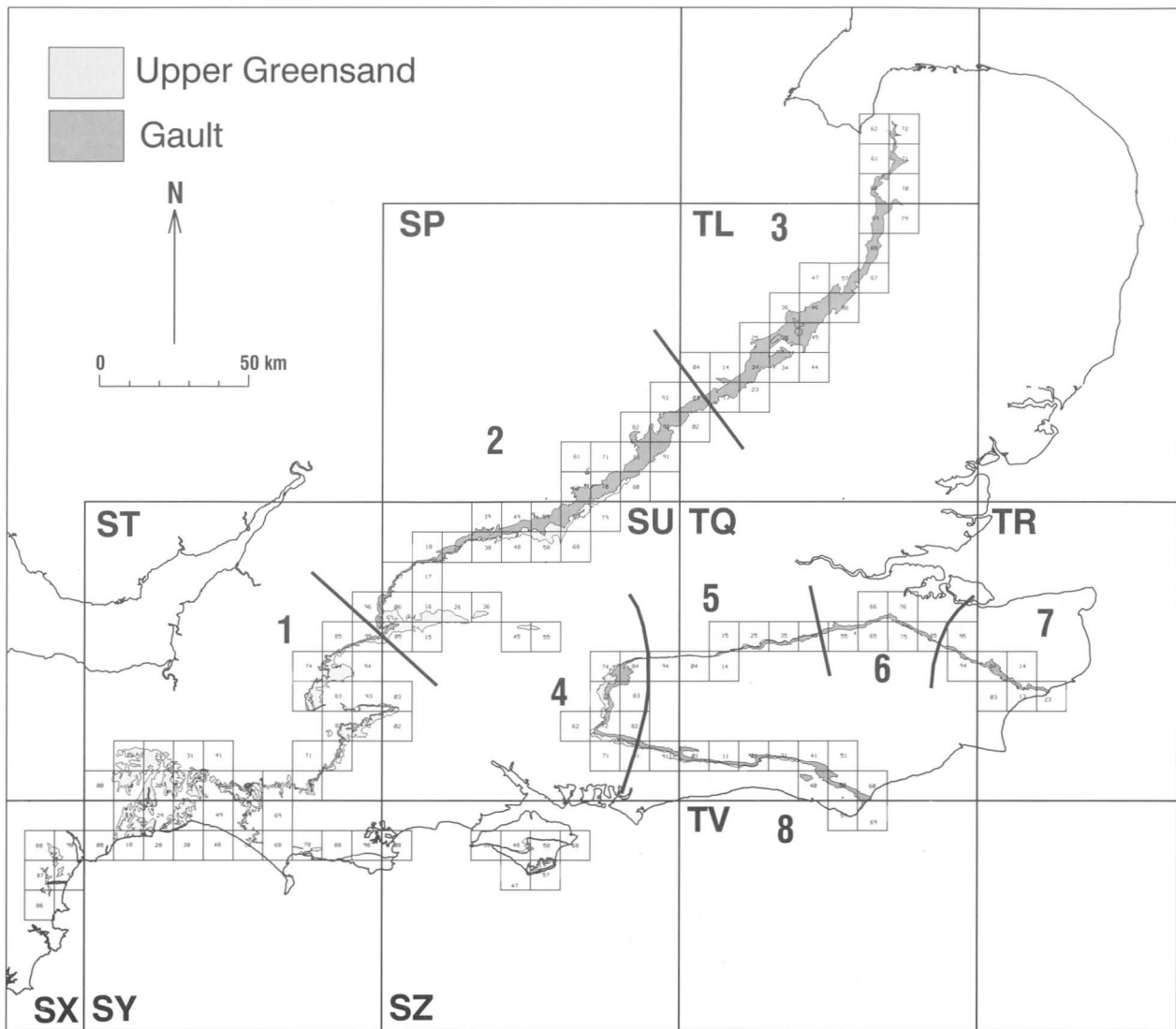

Figure 5.1 The areas used for statistical examination of regional variation in geotechnical properties.

For the data analysis and presentation, the approach has been to use ‘robust’ statistics, based on percentiles, rather than conventional or ‘classical’ parameters. A percentile is the data value below which a given percentage of the data falls. For example, if the 10th percentile of a set of data values is 57 then 10% of the values will be less than 57, and 90% will be greater. The median, or 50th percentile, is the most commonly used, as the central measure of a distribution. The 25th and 75th percentiles are also widely used and are known as the lower quartile and the upper quartile respectively. A commonly used measure of spread of a distribution is the Inter Quartile Range (IQR), i.e. the difference between the upper and lower quartiles.

5.4.2 Box plots

The box plot is a simple compact graphical method of summarising a frequency distribution, based on the robust median and quartiles. The alternative term ‘box and whisker’ plot is also in use.

The ends of the box are drawn at the lower and upper quartiles (25th and 75th percentiles) with an internal division at the median value. Side bars or ‘whiskers’ are conventionally drawn from these ends to the lowest and highest data values that are not ‘outliers’. Outliers are usually represented by individual crosses beyond the

whisker ends. Simple summaries of the frequency distributions of several batches of data may be compared by drawing parallel box plots to a common data scale.

With a box plot it is possible to grasp the major aspects of a distribution at a glance. The centre of the distribution is shown by the median crossbar within the box. For an indication of spread, the interquartile range is shown by the length of the box. The whiskers illustrate the tail lengths of the distribution. The relative position of the median crossbar within the box and the relative lengths of the whiskers indicate the skewness of the distribution.

To a first approximation the confidence with which the parameters of an actual distribution can be used to infer those of the total population increases as the square root of the number of data values. Thus, if the height of the boxes is drawn in proportion to the square root of the size of each data set, the relative significance of each can be compared.

As a summary of a geotechnical property distribution the box plot has two particular limitations. First is the simple convention to determine whether a value will fall within a tail whisker or be classed as an outlier. The lower and upper cutoffs are $1.5 \times \text{IQR}$ below the lower and above the upper quartiles respectively. However this approach is rather too simplistic where the distribution exhibits appreciable non-Gaussian kurtosis. In these cases reasonable tail values will

be classed as outliers and vice versa. It would be preferable to determine the two cutoffs separately, with regard to the distribution in each tail area. This would also help in determining a realistic spread or 'range' within which the great bulk of the data distribution falls.

The second is again concerned with the tail areas. By far the greatest distinction between the many distributions encountered is to be found in the tail areas. The mid part of a distribution is usually very well defined by just the median and quartiles. The conventional box plot gives minimal information beyond the quartile box.

5.4.3 Extended box plots

A refinement of the box plot has been devised (Hallam, 1990) to provide a more comprehensive representation of the frequency distribution of geotechnical data sets particularly in the tail areas. This is referred to as the 'extended box plot' and is used here for statistical data summaries for most of the geotechnical parameters of the Gault.

These plots are constructed from the 0.5th, 2.5th, 10th, 25th, 50th, 75th, 90th, 97.5th and 99.5th percentiles of the data sets. The selected percentiles have been chosen as a compromise between practical geotechnics and statistical rigour. For the former, the simple percentages should be readily recognisable and useful. For the latter, the selection is such that the percentages plot at approximately equal intervals for normally distributed data.

The 25th, 50th and 75th percentiles are used to construct a central box with median division, as for the standard box plot. The remaining percentiles are used to define a series of subsidiary boxes to either side of the central box. In order to distinguish between, and readily recognise, the successive boxes, they are shaded alternately from the centre in complimentary pairs. Thus the outer limits of the shaded boxes will fall at the 0.5th, 10th, 90th and 99.5th percentiles.

By comparing the relative width of the boxes, an indication of the skewness, and even the kurtosis, of the data distributions may be obtained, as they will be of almost equal width for a normal distribution where the data scale is drawn arithmetically. Logarithmic scaling is used for those parameters which generally have distributions that are approximately log-normal. Various measures of the spread or variability of the data can be determined from symmetrical pairs of the percentiles. For example 95% of the data will fall between 2.5th and 97.5th percentiles.

Typically, most actual data sets will be of insufficient size to calculate the outer percentiles and will have only perhaps one or two data values 'contained' within the outermost boxes. Therefore, to ensure that the plot is reasonably meaningful, it is necessary to relate the number of subsidiary boxes to the size of the data set. In order that the outermost box, at each end, should contain a minimum of three values and that at least two further values should fall beyond this box, the following relationship shown in Table 5.1 is used:

The number of available data values is statistically very important. To a first approximation, the statistical significance of the data summary is proportional to the square root of this number. The height of each box within the plots should therefore be drawn in direct proportion to the square root of the number of data values that fall within it. Limitations of the graphics software used to display the

data did not permit this to be achieved, but a series of box heights are used which approximate to the required effect for sets of an average size within each of the above categories. The statistical significance that can be given to each data summary is therefore reflected in both the height of the plot and the number of boxes that it contains.

The lines drawn beyond the outer boxes extend to the minimum and maximum values in the data batch. As the outer boxes of any plot are necessarily based on a minimal number of data values, the quantitative information that they portray should be treated with great caution. The tail lines beyond these boxes will have virtually no statistical significance.

Extended box plots offer the following advantages:

- Compact graphical displays are used to compare the distributions of several data sets.
- The distribution centre and several measures of its spread are shown.
- The height of each display and the number of subsidiary boxes indicate the significance which should be given to each data set.
- Being based on percentiles, the box plot is resistant to any major disturbance by gross outliers and is not dependant on any underlying frequency distribution. It emphasises the structure of the bulk of the data.
- The outermost boxes indicate the rough limits to which any statements concerning the distribution tails can be justified as at all meaningful (the outermost limit shown should always be treated with considerable caution). Thus it may be of practical use to say that 90% of the actual data have values above 'x', or 95% fall between 'y' and 'z', whereas the conventional range (between the most extreme values) is virtually worthless.

This graphical form of statistical presentation was devised to provide a rapid and reliable summary of the 'centre' and spread of each data set and the relative confidence that should be placed in these. The summaries of the geotechnical data are useful guides to the engineering properties of the Gault provided the limitations in the quantity and quality of the source data are remembered and over-interpretation is avoided.

It is stressed that the summary geotechnical values should be used as a general guide only and not as a substitute for adequate site investigation, or in detailed design calculations.

Table 5.1 Relationship between size of dataset and number of subsidiary percentile boxes shown.

Number of samples	Parameter values shown
≥5	50th percentile (Median)
≥10	25th and 75th percentiles (lower and upper quartiles)
≥25	10th and 90th percentiles
≥100	2.5th and 97.5th percentiles
≥500	0.5th and 99.5th percentiles

6 Geotechnical properties

6.1 PARAMETER RANGE AND THEIR VARIATION

The geotechnical properties of Gault clay, as collected for the database, are described in this section. The data were obtained from tests carried out by the BGS — Engineering Geology and Geophysics Group and from test results reported in site investigation reports.

It is stressed that the geotechnical values quoted should be used as a general guide only and not as a substitute for adequate site investigation, or in detailed design calculations.

‘Box-and-whisker’ plots are used to give an impression of the distribution of values of widely used ‘index’ test parameters, whilst scatter plots show the correlations between specific parameters or the variation of a parameter with depth in a borehole. Only geotechnical parameters gathered in sufficient numbers for valid statistical analysis are discussed.

Although the use of non parametric statistics is advocated in Chapter 5, and have been used to analyse the data in the geotechnical database, it is recognised that some readers are more familiar with data being expressed as arithmetic means. In order to make the data as useful as possible and for comparison with data quoted elsewhere the arithmetic mean has also been quoted in this chapter where it is thought to be helpful.

The arithmetic means of the basic index parameters for each area are summarised in Table 6.1. Figures 6.1 to 6.12 show separate ‘box and whisker’ plots for each of the Gault clay ‘areas’ (1 to 8) described in section 5, as well as for the Arlesey (Ar), Klondyke (Kl), and Harwell (Hw) boreholes. The topmost ‘box and whisker’ in each figure (‘All’) represents the combined data for all areas and boreholes. It should be noted that in some figures logarithmic scales are used, where the parameter tends to follow a log-normal distribution.

The values of the geotechnical parameters determined from samples from the Harwell borehole reflect the fact

Table 6.1 Arithmetic means of the basic index parameters for each Area.

Area	Arithmetic Means				
	δ (Mg/m ³)	M/C (%)	LL (%)	PL (%)	PI (%)
1	1.94	24.1	53.9	24.4	29.5
2	1.91	29.9	89.2	30.3	58.9
2*					49.8
3	1.94	28.2	70.1	27.3	42.8
4	1.98	28.2	71.8	27.9	43.9
5	1.93	29.1	75.8	32.0	43.8
6	1.97	28.2	74.7	29.1	45.6
7	1.91	25.5	70.3	23.3	46.9
8	1.95	27.9	74.8	29.0	45.7

2* excluding data from the Harwell boreholes.

that these samples were taken from a Gault clay subcrop at depths of between 87 m and 155 m below ground level, and have not, therefore, been subject to weathering or the degree of stress relief associated with Gault clay at outcrop. Some of the samples also contain very high smectite contents. Therefore, the values appear to be anomalous when compared with results obtained from other areas. This is demonstrated by the relatively high values of bulk density (median 2.07 Mg/m³), dry density (median 1.67 Mg/m³), low moisture content (median 22%) and the liquid limit, plastic limit and plasticity index results which are shown in Figures 6.4, 6.5, and 6.6. These extremely high liquid limits (>160%) and plasticity indices (>110%) are due to high smectite contents (Milodowski et al., 1982, Horseman et al., 1982) and are discussed in relation to mineralogy in Chapter 3.

6.1.1 Density

Figure 6.1 shows that the medians for bulk density lie between 1.89 Mg/m³ and 2.01 Mg/m³, with 1.94 Mg/m³ as the overall median. This figure, as is the case with many others, tends to be dominated by Area 6 (Figure 5.1). Figure 6.2 shows that the median values for dry density lie between 1.47 Mg/m³ and 1.53 Mg/m³, with the exception of Area 1 (Figure 5.1).

6.1.2 Moisture content

Figure 6.3 shows the ‘box and whisker’ plot for moisture content. Moisture content medians vary from 26% to 30% with the exception of Area 1 (median 23%). The overall median is 28%.

6.1.3 Atterberg limits

Figures 6.4, 6.5, and 6.6 show the ‘box and whisker’ plots for the results of Atterberg limit index tests, i.e. liquid limit, plastic limit, and plasticity index, respectively. These plots are dominated, in terms of sample numbers, by Area 6. The liquid limit medians vary from 68% to 80%. Area 1 stands out by virtue of its low liquid limit values. The plastic limit medians vary overall from 23% to 32%. Area 7 exhibits the lowest plastic limit results. The trends in plasticity index are not dissimilar to trends in liquid limit. Plasticity index medians range from 41% to 48%, except Area 1 (27%). With the exceptions of Areas 1 and 2 the arithmetic means for plasticity index are very similar; ranging from 42.8% to 46.9%. The Area 1 and 2 means are 29.5% and 58.9%, respectively.

6.1.4 Specific gravity

There are few values for specific gravity (or particle density), G_s, in the database and no values for most areas. Values range from 2.60 to 2.87 overall, with a median of 2.74. Values from Area 5, though sparse, are notably lower than these (G_s = 2.65). These compare with values of between 2.71 and 2.73 from the Ely–Ouse tunnel project which lie in area 3 (Samuels, 1975).

6.1.5 Particle size

Apart from values from the Arlesey, Klondyke Farm, and Harwell boreholes only 34 determinations of particle size were collected. The clay size content (<2 µm) for Gault clay varies from 15% to 65%, though the lower limit is quoted elsewhere as lying between 35% to 40% (Cripps and Taylor, 1981). The silt size content (2 µm to 60 µm) is often similar to the clay size content. Particles larger than 2 mm (coarse sand) usually constitute less than 1% of the whole. The clay content at Arlesey ranges from 44% to 61%, and at Klondyke Farm from 21% to 61%. Standard particle size and 'sedigraph' analyses from the Arlesey and Klondyke Farm boreholes (Prior et al., 1993) show that the silt size and clay size components tend to be well graded, i.e. have an approximately log-linear grading plot, though this is not always the case. An envelope of grading plots is shown in Figure 6.7. The relationship between clay size fraction and plasticity index is discussed in section 6.3. The mineralogy of the clay size fraction was discussed in detail in Chapter 3.

6.1.6 Chemical tests

Results from four chemical tests are contained in the database: sulphate content, pH, organic content and carbonate content (Anon, 1990a) Figure 6.8 shows the 'box and whisker' plot (log scale) for total sulphate content combined with the BS 5930 (Anon, 1981a) sulphate classification 1 to 5 based on the recommendations of the Building Research Establishment (Table 6.2). Generally, the results fall into classes 1 and 2. However, some data values extend to classes 3 and 4 with only Area 2 having results in class 5.

Table 6.2 Classification of soil for precautions against sulphate attack on buried concrete based on total sulphate content*.

Total sulphate content %	Class
<0.2	1
0.2–0.5	2
0.5–1.0	3
1.0–2.0	4
>2.0	5

Increasing potential for attack
↓

* This is based on BRE Digest 250, 1981 now superceded by Digest 363, 1991.

The 'box and whisker' plot for pH (Figure 6.9) shows values for pH ranging from 3.4 to 9.1. The overall median is 7.7, with medians for all areas ranging from 7.4 to 8.0. The Harwell data give a median for pH of 8.9 with an overall trend of decreasing pH with depth. Areas 2, 6 and 8 have pH values in excess of 8 and only a small number of very low values are found in Area 7.

Very few organic content determinations were collected for the database. All of these are from the Harwell boreholes. Here, values for organic content range from 1.07% to 2.00%, with an arithmetic mean of 1.44%. Organic contents from the Ely–Ouse tunnel (Samuels, 1975), obtained by bulk rock chemical analysis, ranged from 0.4% to 0.8%.

Carbonate contents are very variable and range overall from 1.5% to 66.0%, with an arithmetic mean of 39.2%. The highest values are from Area 6 (Figure 5.1) and indicate a 'marl' rather than a clay. Areas 1, 4, 5, 7, and 8 are, however, unrepresented in the database. Data from the Ely–Ouse tunnel (Samuels, 1975) show carbonate contents ranging from 9% to 19%. In general, the Upper Gault is more calcareous than the Lower Gault. Whilst there is a general negative correlation between carbonate content and plasticity (Marsh and Greenwood, 1992), in some cases high carbonate contents may be accompanied by high clay size contents and high activity clay minerals as at Harwell (Milodowski et al., 1982; Hobbs et al., 1982). A summary of chemical test results is shown in Table 6.3. It should be noted that it is derived from geotechnical classification tests made according to the procedures described in BS 1377 (Anon, 1990a), as distinct from the quantitative mineralogical determinations described by Prior et al. (1993).

Table 6.3 Arithmetic means and medians for chemical test results.

	pH	Total Sulphate (%)	Organic content (%)	Carbonate content (%)
Arithmetic mean	7.7	0.3	1.1	39.2
Median	7.7	0.2	1.0	41.0

6.1.7 Strength tests

Figures 6.10, 6.11, and 6.12, show the 'box and whisker' plots for the results of triaxial strength laboratory tests (i.e. cohesion, c_u , effective cohesion, c' , and effective friction angle ϕ'). Areas 5 and 8 are not represented in the effective strength data. The cohesion results were mainly obtained from 'quick undrained' or 'unconsolidated undrained (UU)' triaxial strength tests. The cohesion is the intercept of the failure 'envelope' on the Y-axis of the Mohr-circle plot (Head, 1986). Usually, a ϕ' of zero is assumed in these tests. Effective cohesion, c' , and effective friction angle ϕ' are usually obtained from 'consolidated undrained (CU)' or 'consolidated drained (CD)' triaxial tests. Total cohesion data are shown in Figure 6.10. Figures 6.10 and 6.11 are plotted on a log scale and hence the representation of the results is skewed towards zero. It should be noted that apparent inter-area variations may be influenced by sampling and testing techniques. Triaxial strength (and oedometer consolidation) summary data for the Arlesey and Klondyke Farm boreholes are given in Table 6.4; details are given in a series of separate reports (see references and bibliography), but statistical assessments are included in the summaries for Area 3. The 'box and whisker' plots show medians ranging from 85 kPa to 148 kPa for total (triaxial-undrained) cohesion, c_u , and from 0° to 7° for total (triaxial-undrained) friction angle, ϕ_u . The highest c_u median is for Area 1 and the lowest for Area 4. Medians for effective cohesion, c' , range from 7 kPa to 80 kPa, and for effective friction angle, ϕ' , from 3° to 24°. With the exception of Area 1, medians for c' are very similar, ranging from 21° to 24°. The total cohesion, c_u , when normalised to estimated present overburden pressure, P_o , gives median values of c_u/P_o ranging from

Table 6.4 Arlesey and Klondyke Farm Borehole — oedometer and triaxial test summary data.

<i>OEDOMETER</i>											
BH	Depth m	MC %	$\gamma_{b(0)}$ Mg/m ³	e_0	σ'_{sw} kPa	P_c' kPa	Cc	Ce	$k_{oed(p)}$ $\times 10^{-11}$ m/s	Mv(p) m ² /MN	OCR
Arlesey	15.7	28.0	1.95	0.82	114	430	0.16	0.08	1.6	0.07	2.9
Arlesey	34.5	24.0	2.02	0.69	41	371	0.08	0.04	3.5	0.04	1.1
Arlesey	46.4	27.1	1.97	0.78	73	354	0.12	0.06	1.8	0.05	0.8
Klondyke	6.8	27.8	1.96	0.77	147	330	1.10	0.06	—	—	5.2
Klondyke	10.6	27.7	1.97	0.79	138	400	0.12	0.08	—	—	4.0
Klondyke	14.5	25.0	2.00	0.71	244	502	0.10	0.06	—	—	1.6
Klondyke	23.5	29.5	1.93	0.84	106	358	0.15	0.09	11.2	0.10	1.6
Klondyke	27.0	28.2	1.93	0.82	170	473	0.13	0.08	4.0	0.05	1.9

<i>TRIAXIAL</i>											
BH	Depth m	MC %	$\gamma_{b(0)}$ Mg/m ³	$\gamma_{d(0)}$ Mg/m ³	$k_{(100)}$ $\times 10^{-11}$ m/s	Mvi ₍₁₀₀₎ m ² /MN	c' kPa	ϕ' degr	θ degr	S' kPa	
Arlesey	35.5	24.0	2.00	1.63	3.10	0.10	73.0	19.4	38	193	
Klondyke	6.8	27.8	1.99	1.53	12.70	0.16	12.7	23.5	32	41	
Klondyke	10.5	27.7	1.94	1.54	5.40	0.35	23.6	27.3	33	74	
Klondyke	14.5	25.0	2.00	1.60	6.40	0.18	29.9	24.2	38	92	
Klondyke	23.5	29.5	1.99	1.49	2.60	0.19	22.6	25.0	44	129	
Klondyke	27.0	28.2	2.02	1.51	3.10	0.15	29.3	22.5	341	38	

- MC = moisture content
- $k_{oed(p)}$ = permeability at estimated overburden
- Mvi₍₁₀₀₎ = coefficient of volume compressibility, (isotr) $\sigma_3 = 100$
- Cc = compression index
- c' = effective cohesion
- Ce = swelling index
- ϕ' = effective friction angle
- Mv(p) = coefficient of volume compressibility at estimated overburden
- θ = shear plane angle (to horizontal)
- σ'_{sw} = swelling stress
- $k_{(100)}$ = permeability at σ_3' of 100–150 kPa
- P_c' = estimated yield stress
- OCR = overconsolidation ratio
- S' = effective shear strength
- $\gamma_{b(0)}$ = initial bulk unit weight
- $\gamma_{d(0)}$ = initial dry unit weight
- e_0 = initial voids ratio

0.63 to 1.53; the lowest representing Areas 4 and 6, and the highest Area 7. (present overburden pressure has been estimated using the arithmetic mean bulk density for each Area). Arithmetic means for the triaxial strength parameters of each Area are given in Table 6.5.

Total shear values strength derived from unconfined compression test data at Harwell give a range for s_u , of

Table 6.5 Arithmetic means for the triaxial strength parameters of each Area.

Arithmetic means					
Area	c_u (kPa)	ϕ_u (°)	c' (kPa)	ϕ' (°)	c_u/P_o
1	183	0	80	3	1.1
2	109	2	7	23	1.07
3	121	0	35	23	1.31
4	106	8	11	24	0.71
5	161	0			
6	117	5	13	24	0.93
7	121	4	66	22	1.84
8	129	3			

340 kPa to 1840 kPa in the Gault at depths of between 84 m and 132 m (Horseman et al., 1982).

Total (undrained) shear strength, s_u , is calculated from the following formula:

$$s_u = c_u + \sigma_n \tan \phi_u$$

where σ_n is the normal stress, taken here as the overburden pressure. Thus, when ϕ_u is zero then $s_u = c_u$. Ideally ϕ_u should equal zero, however, factors such as fissuring and non-saturation of clays may result in the Mohr-circle failure envelope having a positive gradient at low applied stresses, and hence ϕ_u having a positive value. In many site investigation reports no value for ϕ_u is given and the assumption is made in these cases that it is equal to zero. Effective shear strength, s' , is here derived from either consolidated-drained or consolidated-undrained (with pore pressure measurement) triaxial tests, using the following formula:

$$s' = c' + \sigma_n \tan \phi'$$

The shear strength of a clay tends to increase with depth of burial for a given lithology. The variation of shear strength with depth for Gault clay is discussed in section 6.2.

Gault clay is well known to be susceptible to landsliding (Chandler, 1984; Toms, 1953; Hutchinson, 1969; Hutchinson et al., 1980; Gostelow, 1990; Gostelow, 1991; Hobbs, 1990; Forster, 1992). Residual strength is an important parameter in the case of Gault clay, as it determines the strength along pre-existing shear planes, and hence is crucial in the quantitative analysis of slope stability. Few data are available for residual strength from the database. Determinations of residual strength, using the Bromhead ring-shear apparatus, were carried out on samples from the Arlesey and Klondyke Farm boreholes (Entwisle, 1993), and for a landslide at Shaftesbury (Entwisle, 1992). Denness (1969) and Humphris (1979), reported in Chandler (1984), made determinations of residual shear strength, using reverse shear box tests and ring shear tests, respectively, for Gault clay at Blackgang, Isle of Wight. Values of effective residual friction angle, ϕ_r' , from the Arlesey and Klondyke Farm boreholes range from 9° to 25°. At Shaftesbury ϕ_r' ranges from 10° to 25° with striking differences locally across landslide shear zones. Similar ranges are reported for ϕ_r' at Blackgang: 7° to 25°; differences at certain levels within the Gault succession have been attributed to lithological changes (Chandler, 1984).

Estimates of residual shear strength, s_r' , at Arlesey and Klondyke Farm range from 49 kPa to 76 kPa and 14 kPa to 40 kPa, respectively. At Shaftesbury values of s_r' range from 9 kPa to 24 kPa. Results of these tests are summarised in Table 6.6. Hutchinson et al. (1980) quoted values for ϕ_r' of 12° for 'low liquid limit' Gault and 7° for 'high liquid limit' Gault at normal effective stresses at Folkestone Warren. Values derived from back analysis at Folkestone Warren tend to be several degrees higher. Values of effective residual friction angle, ϕ_r' , are dependent on the value of normal effective stress applied. Thus care should be taken that values are compared at similar stresses.

Total and effective shear strength data from the Klondyke Farm borehole are summarised in Table 6.4. Values of effective cohesion, c' , range from 12.7 kPa to 29.9 kPa for Klondyke Farm (Arlesey has a single c' value of 73 kPa at 35.5 m). Effective friction angle, ϕ' , ranges from 22.5° to 27.5° (19.4° at Arlesey). Values of effective shear strength, s' , range from 4 kPa to 138 kPa for

Klondyke Farm (Arlesey has a single s' result of 193 kPa at 35.5 m). As might be expected, s' increases steadily with increasing depth as shown by data from other deep boreholes (Figure 6.13).

6.1.8 Swelling tests

Gault clay is susceptible to swelling and shrinkage, following an increase or decrease, respectively, of moisture content. Swelling and consolidation data are relatively uncommon in site investigation reports compared to other geotechnical data and are consequently poorly represented in the database. Data are available from the Harwell boreholes, from the Ely–Ouse site investigation and from Area 2. Swelling indices, C_e , from oedometer tests from the Ely–Ouse boreholes range from 0.02 to 0.19, and swelling pressures from 200 kPa to 1250 kPa (Samuels, 1975). A wide scatter of swelling values is found and no clear trend with depth is apparent. Samuels (1975) reported swell sensitivity ranged from 3.3 to 5.6 (block samples only). This is indicative of diagenetic/chemical bonding which may be broken by sample disturbance and remoulding. Swelling data from Harwell (Hobbs et al., 1982) again showed a wide scatter of data and a poor correlation of swelling parameters with Atterberg limits, depth, or clay mineralogy, though an inverse relationship between clay mineral (interplate) half-distance and swelling pressure may be inferred (Madsen and Muller-Von Moos, 1985). However, the 'free swell' test data show a zone of high values (>200%) coincident with the high smectite content and high plasticity values zone at the top of the Gault. At Harwell the swelling pressures range from 110 kPa to 620 kPa and the free swell values from 140% to 340%, thus placing the Gault entirely within the 'high swelling potential' category (>100%) of Holtz and Gibbs (1956).

6.1.9 Consolidation tests

Compressibility data from the Arlesey and Klondyke Farm oedometer tests are summarised in Table 6.4. These indicate a coefficient of volume compressibility, M_v , (at equivalent effective overburden stress) of 0.05 m²/MN to 0.10 m²/MN for Klondyke Farm and 0.04 m²/MN to 0.07 m²/MN for Arlesey. Here, the value of M_v tends to either decrease uniformly with depth, or to increase to a stress close to the pre-consolidation stress, P_c' , and then to decrease uniformly with further stress increase. Compressibility data from Area 2 (Marsh and Greenwood, 1992), largely derived from SPT tests, show an overall decrease in M_v with depth (to 20 m) from values of 0.28 m²/MN to 0.02 m²/MN. Hyde and Leach (1975) quote M_v values of 0.02 m²/MN to 0.12 m²/MN for the Gault at Didcot (Area 2). Compression index, C_c , for Arlesey and Klondyke Farm ranges from 0.08 to 0.16 and 0.1 to 1.1, respectively, whilst swelling (rebound) indices, C_e , range 0.04 to 0.08 and 0.06 to 0.09, respectively.

Values of pre-consolidation (estimated maximum previous overburden) stress range from 354 kPa to 430 kPa for Arlesey and 330 kPa to 502 kPa for Klondyke Farm. These

Table 6.6 Arlesey, Klondyke Farm and Shaftesbury — residual strength test summary data.

BH	Depth (m)	LL (%)	PL (%)	PI (%)	Smec. (%)	Clay (%)	c_r' (kPa)	ϕ_r' (kPa)
Arlesey	15.0	40	20	20	12.6	26	3.3	23.0
Arlesey	18.0	80	27	53	18.8	46	1.5	13.7
Arlesey	42.0	75	29	46		57	1.4	10.9
Klondyke Farm	4.0	63	26	37	13.0	48	4.7	14.7
Klondyke Farm	11.0	72	25	47	17.5	50	4.5	10.1
Klondyke Farm	26.0	83	23	60	23.8	21	2.7	8.7
Shaftesbury, BH1	10.8					38	3.8	10.2
Shaftesbury, BH2	5.64					32	1.1	24.5
Shaftesbury, BH2	5.65					46	3.5	7.4
Shaftesbury, BH2	5.66					46	3.2	9.3

c_r' = Effective residual cohesion
 ϕ_r' = Effective residual friction angle
 Clay = Clay size fraction, <2 μ (% of whole rock)
 Smec. = Smectite content (% of whole rock)

data give estimated over-consolidation ratios, OCR, of 0.8 to 2.9 for Arlesey and 1.6 to 5.2 for Klondyke Farm. These translate to inconsistent estimates of the 'maximum erosion', with a range from -9.3 m to $+30.0$ m for Arlesey and $+8.7$ m to $+24.3$ m for Klondyke Farm. Pre-consolidation stresses in the range 3350 kPa to 3850 kPa are quoted for Folkestone Warren by Hutchinson (1969). Matthews (1977) suggested values greater than 5000 kPa for the Isle of Wight. These are an order of magnitude higher than those from Arlesey and Klondyke Farm, but reflect the greater depth of the samples at Folkestone and the Isle of Wight.

Values of the coefficient of consolidation, C_v , range from 0.4 m²/yr to 10.4 m²/yr for Arlesey and 1.0 m²/yr to 6.7 m²/yr for Klondyke Farm. These result in estimates for the oedometer permeability, $k_{(oed)}$, of between 1.6 to 3.5×10^{-11} m/s and 4.0 to 11.2×10^{-11} m/s, respectively. Hutchinson et al. (1980) quoted a value for field permeability, k , of 7.3×10^{-11} m/s for slip zone Gault clay. The higher values of C_v are not confined to the weathered Gault and are generally higher than those quoted by Cripps and Taylor (1981). Initial swelling pressures, σ'_{sw} , measured in the oedometer, ranged from 41 kPa to 114 kPa for Arlesey and 106 kPa to 244 kPa for Klondyke Farm. Voids ratio vs. (log) stress plots for Arlesey and Klondyke Farm are of similar shape with a marked high rebound (high C_e value). Values for secondary consolidation, C_{α} , from the oedometer test, range from 0.0002 to 0.002 at Arlesey and 0.0003 to 0.0017 at Klondyke Farm. The trend is for an overall increase in C with increasing applied stress.

Consolidation data are difficult to convey in a database format. Values of C_v and M_v may be quoted at specified stresses such as 100 kPa or 200 kPa, or at a stress equivalent to the estimated overburden stress. Oedometer tests from different sources tend, however, to be carried out at different stress increments which depend on specimen size, test equipment etc. It is possible to interpolate between stresses, but this is not always reliable.

6.2 DEPTH PROFILES

The majority of boreholes represented in the geotechnical database are less than 30 m depth. The exceptions are given in Table 6.7. Of these, only the Harwell, Arlesey, and Klondyke Farm boreholes penetrate the Gault sub-crop, 87 m below G.L. at Harwell and 15 m and 4 m at Arlesey and Klondyke Farm, respectively. Investigations at Didcot Power Station (Hyde and Leach, 1975) penetrated over 40 m of Gault. In addition, the Ely–Ouse tunnel boreholes penetrated the Gault sub-crop at between 20 m and 80 m below G.L. (Samuels, 1975), the Channel Tunnel boreholes (Varley et al., 1993) at between 30 m and 130 m

Table 6.7 Boreholes in the geotechnical database greater than 30 m depth.

Sheet No.	BGS No.	Depth	Area
SP60SE	68A	49 m	2
SU48NE	93S	94–132 m	2 (Harwell)
TL13SE	45	71 m	3
TQ35SW	132	36 m	5
TQ35SW	144	35 m	5
TQ45NE	1006	35 m	6

below ground and sea floor levels, and the 45 m thickness of Gault clay at Folkestone Warren (Toms, 1953; Hutchinson, 1969; Hutchinson et al., 1980) at a depth of approximately 135 m.

The variations of geotechnical parameters with depth are shown in Figures 6.13 to 6.19. These data are shown in the form of 'scatterplots' (i.e. with data points unrelated to each other), or as 'line plots' (i.e. connected data points from individual boreholes). To produce the line plots, data have been restricted to only those with more than 3 data points in the same borehole. However, scatterplots show all available data points, unless otherwise indicated. Where large numbers of data points are involved, the line plots invariably become jumbled. In the case of the scatterplot it should be noted that no inter-relationship of data points nor geological stratification are implied. Depths are taken from the ground surface in each case.

Figure 6.14 shows the depth profile line plot of natural moisture content (MC) for all data except Harwell. A clear trend is seen of a gradual decrease in natural moisture content with increasing depth. Between ground level and 5 m the decrease in moisture content is marked. However, at a depth of approximately 15 m the moisture content values tend to approach a minimum value of about 25%, below which there is little variation. However, borehole 68A (sheet SP60SE, Area 2) shows moisture content decreasing progressively to a depth of at least 50 m. The few anomalously low natural moisture content values (as low as 5%) are likely to be in error. The scatter becomes more marked at shallow depths, where natural moisture content is affected by the surface environment. The uppermost Harwell moisture content data (95 m–105 m) range between 23% and 27% and do not appear to follow the trend with depth extrapolated from the other, shallower, data, whereas the lowermost Harwell data (119 m–133 m) lie between 20% and 25%.

Natural Moisture Content v Depth plots from the Klondyke Farm and Arlesey boreholes are shown in Figure 6.15. Klondyke Farm values remain largely unchanged with depth (MC = 25%–29.5%) but in the case of Arlesey there is a slight decrease with depth between 17 m and 22 m, below which there is little change with depth, except for an indication of minor cyclicity ranging between 23% and 28%. At Ely–Ouse there is little change in moisture content with depth (Samuels, 1975). However, moisture content data from the Channel Tunnel (not incorporated in the project database) indicate a general increase in moisture content with depth, both within the Gault clay and the overlying Chalk Marl (Varley et al., 1993) values typically ranging from 15% to 25% within the Gault clay between 30 m and 115 m below sea floor. The Folkestone Warren landslide investigation (Toms, 1953; Hutchinson, 1969) gave a moisture content v depth profile for the Gault Clay between c. 140 m and 190 m below G.L., which is essentially uniform at 20%–23% but with three zones of higher moisture content at the top, middle, and bottom of the formation. Also, the moisture content drops below 20% close to the underlying Folkestone Beds. Moisture content data from the Ely–Ouse water tunnel (Samuels, 1975) for the Gault clay, at depths ranging from 19 m to 73 m, again show a uniform depth profile with values close to 25%. Few differences are seen between moisture content profiles 20 km apart and at different burial depths.

Cripps and Taylor (1981) quoted the following ranges of moisture contents for the Gault Clay: 32%–42% (weathered) and 18%–30% (unweathered). The natural moisture content is discussed further in relation to



Plate 2 Selbourne Brickworks. Weathered, desiccated highly fissured Gault clay with water flowing through the oxidised fissures.

liquidity index in chapter 3 (Mineralogy). Samuels (1975) gave the mean natural moisture content for the Ely–Ouse Tunnel as 25.6%. At Folkestone Warren (Hutchinson, 1969) the mean natural moisture content was given as

Plate 3 Arlesey Brickpit. Fresh Gault clay showing concoidal fracture and much less fissuring than the weathered material shown in Plate 2.



22%. The bulk density variation with depth (Figure 6.16) tends to show a mirror image of that for the natural moisture content data.

The variations of total cohesion, c_u , and total (undrained) shear strength with depth are given in Figures 6.17 and 6.18. There is a large amount of scatter that tends to increase with depth. Such scatter is reported elsewhere for Gault clay (Samuels, 1975). This may be due to variations in sample size, testing technique, saturation, and sample disturbance, as well as lithological variability. There does not appear to be a marked increase in cohesion with depth below about 5 m, with the exception of Area 5. Area 5 exhibits an apparently continuing trend of increasing strength with depth down to 35 m, reaching values of 700 kPa. Area 5 accounts for most of the values above 400 kPa in Figure 6.17. Area 6, though adjacent and having a larger data set, exhibits a distinctly lower spread of values at depth. Also, the plot showing ‘envelopes’ of data for each Area (Figure 6.19) reveals an apparent ‘pinching’ of the envelopes of Areas 2, 4, 6, and 8 at approximately 15 m depth. Hyde and Leach (1975) showed the shear strength increasing overall with depth from a value of about 50 kPa at 3 m to about 600 kPa at 35 m depth. This gives a total strength gradient, c_u/D , of approximately +17 kPa/m. Strength gradients for Ely–Ouse (Samuels, 1975), and for a site in Oxfordshire (Area 2) reported by Marsh and Greenwood (1992) are approximately +7 kPa/m and +10 kPa/m, respectively. However, the equivalent gradient at Harwell is negative overall.

Near-surface strength profiles may be influenced by weathering and stress-relief to depths of at least 10 m. However, the depth of weathering is usually quoted as being between 0 m and 5 m, and typically as 3 m. Comparison of weathering descriptions given in site investigation reports is difficult if the standard BS 5930 classification has not been used. In many site investigation reports no direct assessment of weathering is made. Weathering of the Gault is associated with the type and frequency of the fissures present (Plates 2 and 3). Fookes and Denness (1969) described the fissures found in the Gault at sites on the Isle of Wight. They found that the intensity of fissuring

increased with increasing degree of weathering but not that the fissure fabric and size were unaffected. The pattern of fissuring was not altered by minor lithological variation. As samples of the Gault from Harwell are unweathered throughout, the strength variation is clearly due to factors other than weathering including mineralogy, cementation, and structure. This also applies to boreholes from the Ely–Ouse and the Channel Tunnel. Unfortunately, individual strength profiles are not given in Samuels (1975) and for the Channel Tunnel single values of undrained cohesion (derived from unconfined compression strength tests) of 1000 kPa and 1500 kPa are quoted for UK under sea (60 m depth) and under land (130 m depth) sites, respectively (Fugeman et al., 1993). Undrained shear strength values (from unconfined compression strength tests) at Harwell ranged from 340 kPa to 1840 kPa. These appear to have a positive correlation with carbonate content (Horseman et al., 1982).

Compressibility data from Area 2 (Marsh and Greenwood, 1992) showed an overall decrease in the coefficient of volume compressibility, M_v , with depth (to 20 m) from values of 0.28 m^2/MN to 0.02 m^2/MN . The authors equate this trend with the decreasing degree of weathering with depth. Hyde and Leach (1975) quoted M_v values decreasing steadily from 0.12 m^2/MN at 2 m depth to reach a minimum of 0.01 m^2/MN at 42 m depth at Didcot (Area 2). Hutchinson et al. (1980) quoted values for M_v of 0.19 m^2/MN for the Upper Gault and 0.3 m^2/MN for the Lower Gault, and corresponding C_v values of 1.9 m^2/yr and 0.14 m^2/yr ; these values having been obtained from remoulded specimens as part of ring shear tests.

6.3 PARAMETER CORRELATIONS

The relationship between pairs of selected geotechnical parameters, irrespective of depth, is shown in the form of ‘scatterplots’ in Figures 6.20 to 6.27. These can be used to estimate parameters by means of correlations with more easily measured or more widely available parameters, and to classify soils by virtue of their locus on the plot.

A fundamental physical property relationship is that between bulk density (γ_b) and moisture content (w). Deviations from the best-fit line indicate either changes in specific gravity (particle density) or errors in measurement or recording. A plot of $1/\gamma_b \text{ v } 100/(100 + w)$ for all data is given in Figure 6.20. This shows a slightly non-linear, inverse correlation with quite a wide scatter of points.

Classification of soils by their plasticity and related parameters is made using the Casagrande ‘plasticity’ plot and the Skempton ‘activity’ plot (Skempton, 1953). The former relates liquid limit to plasticity index and the latter relates per cent clay size ($<2 \mu$) to plasticity index. These plots are shown for the whole data set in Figures 6.21, 6.22, 6.23, and 6.24. The ‘plasticity’ plot includes the ‘A-line’ which is an arbitrary division between silts/organic soils (below the line) and clays (above the line), and the grouping codes used in the Unified Soil Classification system (Wagner, 1957); it is not a best-fit line to the data points. It will be noted that the linear best-fit (‘t-line’) to the data has a steeper gradient than the ‘A-line’.

The ‘plasticity’ plots in Figures 6.21 to 6.23 show a considerable variation for each area from CL (low) to CE (extremely high) with a small proportion placed below the ‘A-line’, as well as a considerable overlap of areas. These plots do not include the data from the upper part of the profile at Harwell because this gave extremely high

plasticity values not found elsewhere. Although the values were rigorously checked and were consistent in adjacent boreholes the results are so high that the possibility of contamination by drilling mud cannot be completely ruled. The contribution of the Harwell data is shown in Figure 6.23. The Area 1 envelope, in Figure 6.22, is confined to the lower end of the plot, mainly in classes CI (intermediate) and CH. Area 2 (not including Harwell) spans CH, CV (very high) and CE classes. Area 3 covers a relatively small zone mainly within the upper part of the CH and lower part of the CV classes. Area 4 is similar but extends slightly into the CE class. Areas 5 and 6 both have large envelopes which extend well below the ‘A-line’. The Area 6 envelope in particular covers a very wide zone from CL to CE and MH to MV. Area 7 has a long but narrower envelope spanning classes CL to CE with few data points below the A-line, whilst the Area 8 envelope is even narrower and shorter, ranging from CH to CE. The Area 6 envelope is influenced of course by its large data set. Figure 6.23 clearly shows the anomalous Harwell data set located well into the CE class but never-the-less on the same best-fit line. The equation for this overall best-fit (linear) ‘t-line’ is:

$$PI = -16.4 + 0.84(LL)$$

If the Harwell data are removed this equation becomes:

$$PI = -18.9 + 0.86(LL)$$

The equations for individual Areas are as follows:

Area 1	$PI = -16.3 + 0.85(LL)$
Area 2	$PI = -22.5 + 0.91(LL)$
Area 3	$PI = -12.6 + 0.79(LL)$
Area 4	$PI = -3.0 + 0.65(LL)$
Area 5	$PI = -15.0 + 0.78(LL)$
Area 6	$PI = -19.0 + 0.86(LL)$
Area 7	$PI = -10.2 + 0.81(LL)$
Area 8	$PI = -25.8 + 0.96(LL)$

The ‘activity’ plot is used to show the plasticity of the clay size fraction of the soil, and is a function of its clay mineralogy (Skempton, 1953). Values for activity, A_c , range from 0.5 to 3.0, but with most values lying in the range 0.7 to 1.0. These compare with values quoted by Chandler (1984) for Blackgang, Isle of Wight of 0.48 to 0.82. It is clear from Figure 6.24 that despite variations in numbers of data points there is a difference in A_c values from one area to another. The data from Area 3 (all from Arlesey and Klondyke Farm boreholes) are compact and centred in the ‘normal’ classification zone, whereas data from Areas 1 and 5 are widely scattered across the zones. Activity data should be treated with some caution, however, as particle size results for the Gault are often influenced by poor disaggregation of clay minerals during sample preparation.

Correlations between Atterberg limits and other index, chemical, or strength parameters can be made where sampling points coincide. A negative correlation between calcite (or carbonate) content and liquid limit is indicated by Marsh and Greenwood (1992) and Samuels (1975). This correlation is shown for Arlesey, Klondyke Farm, and Harwell in Figure 6.25. It is clear from this plot that the highly plastic upper part of the Harwell Gault plots separately from the rest. The Arlesey and Klondyke Farm data, as well as the lower Gault data from Harwell, appear to lie on a similar line. However, taken in isolation, the Harwell

data would give a positive correlation as the uppermost part (above 120 m depth) has both high plasticity and high carbonate content compared with the lower (below 120 m). Figure 6.25 shows that the correlation only applies locally and cannot be extrapolated more broadly or from Upper to Lower Gault or vice versa. The correlation between carbonate content and strength would be expected to produce a positive correlation.

Correlations between effective residual friction angle, and plasticity index and per cent clay size are given in Figures 6.26 and 6.27, respectively. Generally, these show an inverse correlation, that is effective residual friction angle decreases with increasing plasticity index and with increasing proportion of clay size fraction. However, there are insufficient data, as yet, for this correlation to be used in a predictive manner, and it should be noted that per cent clay size data are unreliable if complete disaggregation has not taken place during sample preparation.

6.4 SUMMATION

Whilst the Gault clay may be described generally as a moderately to extremely plastic, overconsolidated, very stiff to hard, clay soil or a weak mudrock, study of its geotechnical properties has shown that important regional variations in geotechnical properties exist. Consequently engineering behaviour can be expected to vary regionally. These appear to be largely a function of lithology which in turn is a function of depositional environment and stress history. The geotechnical index parameters generally show little variation with depth where the Gault is at outcrop, except near to the surface. For example, the Atterberg limits and moisture contents are frequently constant to depths of 20 m or more. However, in the few instances where the full thickness of Gault is tested at subcrop and at considerable depth, as at Harwell, the Channel Tunnel, and the Ely–Ouse Tunnel, then the picture is different. In these latter cases index properties show greater variation with depth, at Ely–Ouse to a limited extent and at Harwell to a considerable extent. Some minor cyclicality is noted in the case of geotechnical index parameters. These probably relate to minor lithological variations, in particular particle size.

The Atterberg limits appear to bear a relationship to the calcium carbonate content, though this is not necessarily a simple one. The Gault is generally a silty clay, often with similar proportions of silt size to clay size fractions. Despite this, it may be highly plastic and even extremely plastic, due to the relatively high content of smectite within the clay size

fraction. Some determinations of clay size fraction may be inaccurate due to the difficulty of achieving complete disaggregation. This is suggested by comparing clay mineral contents from geochemical analyses and clay size fractions from mechanical analyses. A significant anomalous layer of extremely high plasticity Gault clay has been identified at Harwell with liquid limits as high as 180%. Such levels have not been recorded elsewhere, even in the nearby Didcot area. Zones of high plasticity have been recorded elsewhere but nowhere else does the liquid limit exceed 125%. Whilst the anomalous values at Harwell were repeated in two boreholes and have been rigorously checked, the possibility of drilling mud contamination cannot be totally ruled out.

The clay size particle content has been found to be very variable. The determination of this parameter is subject to experimental error and some data may be underestimates. The relationship between carbonate content and clay size content, and between carbonate content and index geotechnical parameters has been found to be different at different locations. The carbonate content of the Gault is very variable and in some cases Gault clay may be classified as a marl.

The Gault clay is particularly susceptible to landsliding. The key geotechnical parameter for landslide analysis is effective residual strength. Values of effective residual shear strength have been found to be reasonably consistent for a given test type and a given normal applied stress. Values are low for the higher plasticity Gault clays. The Gault clay is also particularly susceptible to swelling and shrinkage in the engineering environment. Swelling data have been found to be disappointingly sparse in the database. Where present, the data on swelling are often unclear and, frequently, do not correlate well with geotechnical index tests. Part of the problem is the diversity of test types and the reported correlations which may have been derived from other soil types. The ‘free-swell’ test is simple and may be a useful index test to use with the Gault clay. However, most indications are that the Gault clay has a high swelling potential and has shown high swelling pressures and swelling strains under certain conditions. Consolidation data have revealed an apparent wide variation in pre-consolidation stresses, as derived from oedometer or triaxial tests. However, reliable data are limited and an areal interpretation is difficult to make with any confidence.

The correlation of geotechnical properties between boreholes or between areas is difficult because of poor or non-existent stratigraphic descriptions of the formations in site investigation boreholes. Biostratigraphic zonation is not yet used in site investigations.

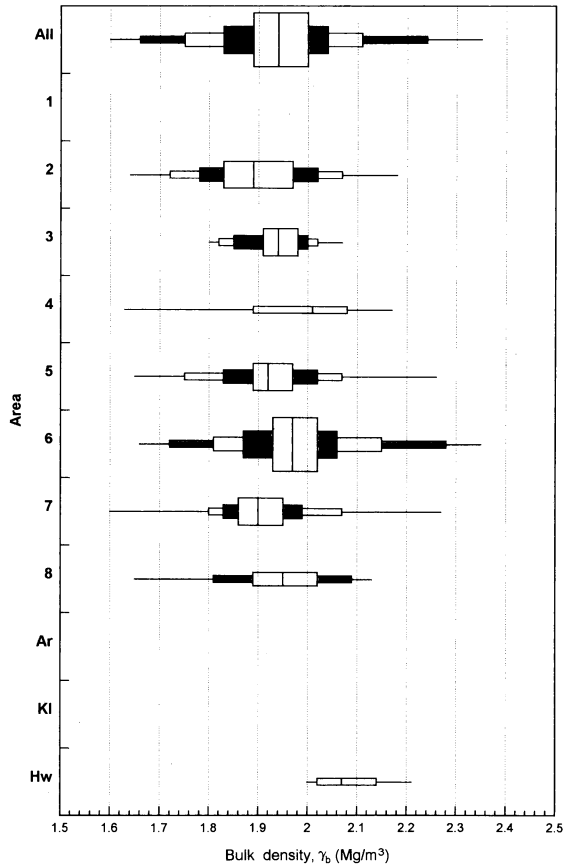

Figure 6.1 Box and Whisker plot: Bulk density, γ_b (Mg/m^3).

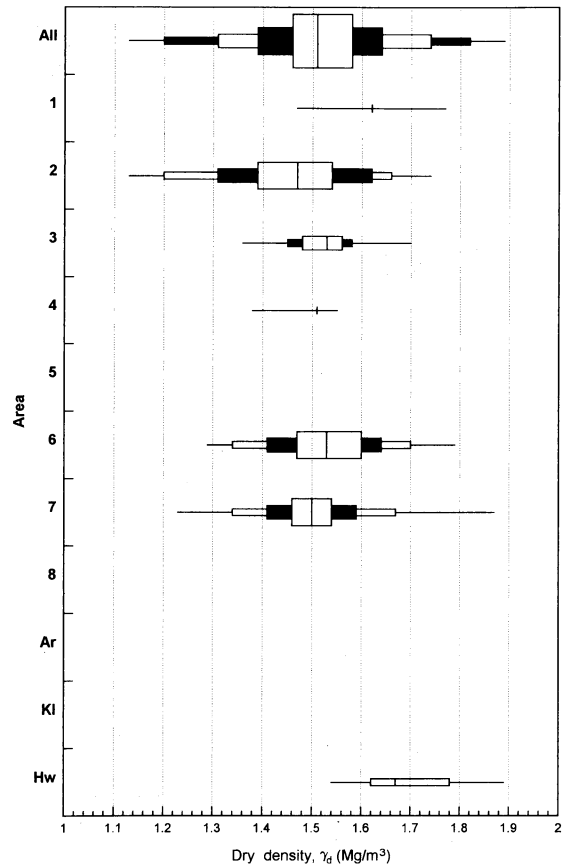

Figure 6.2 Box and Whisker plot: Dry density, γ_d (Mg/m^3).

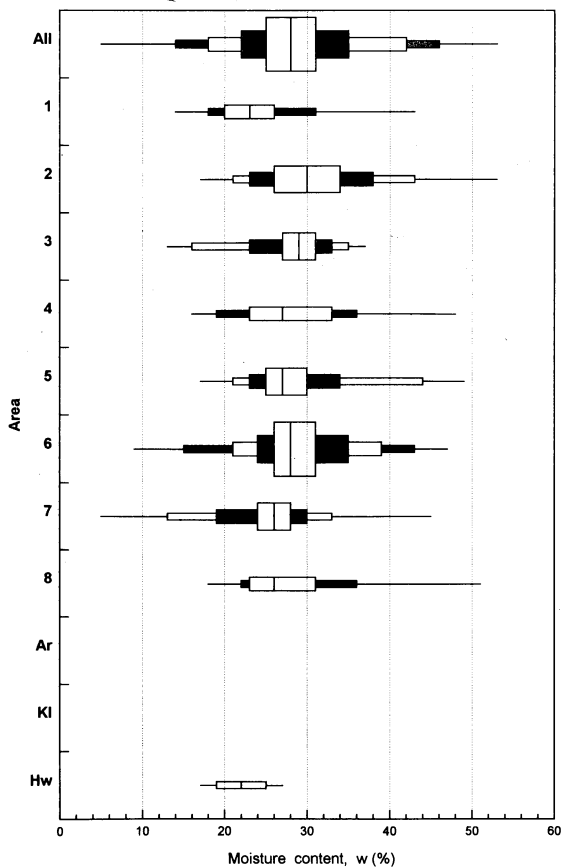

Figure 6.3 Box and Whisker plot: Moisture content, w (%).

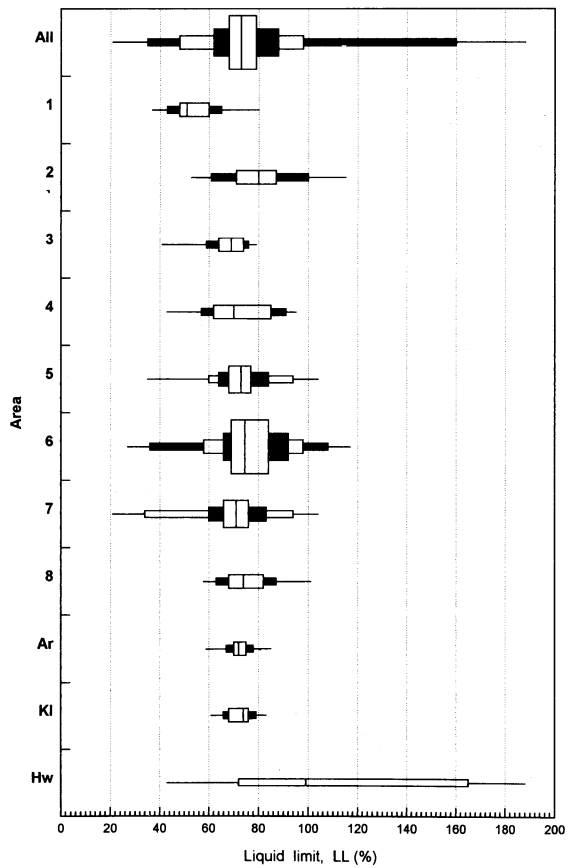

Figure 6.4 Box and Whisker plot: Liquid limit, LL (%).

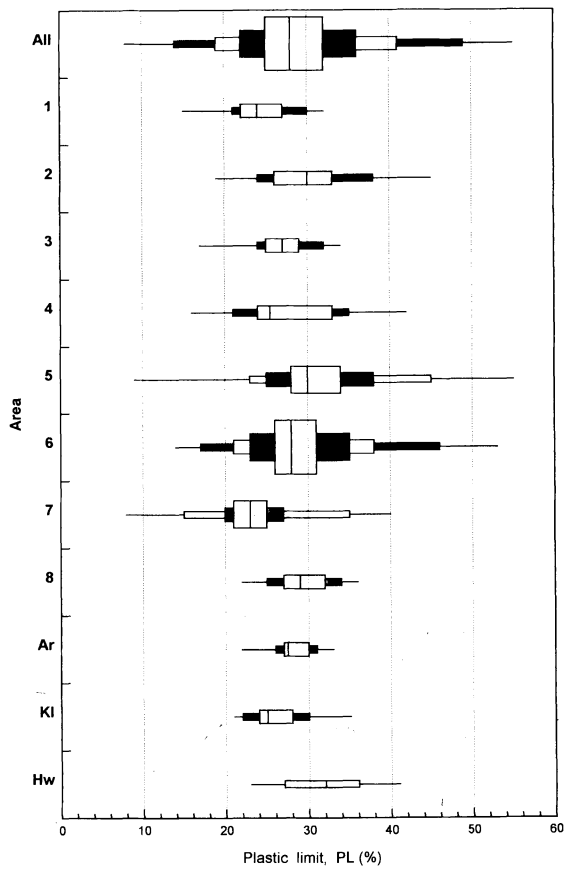

Figure 6.5 Box and Whisker plot: Plastic limit, PL (%).

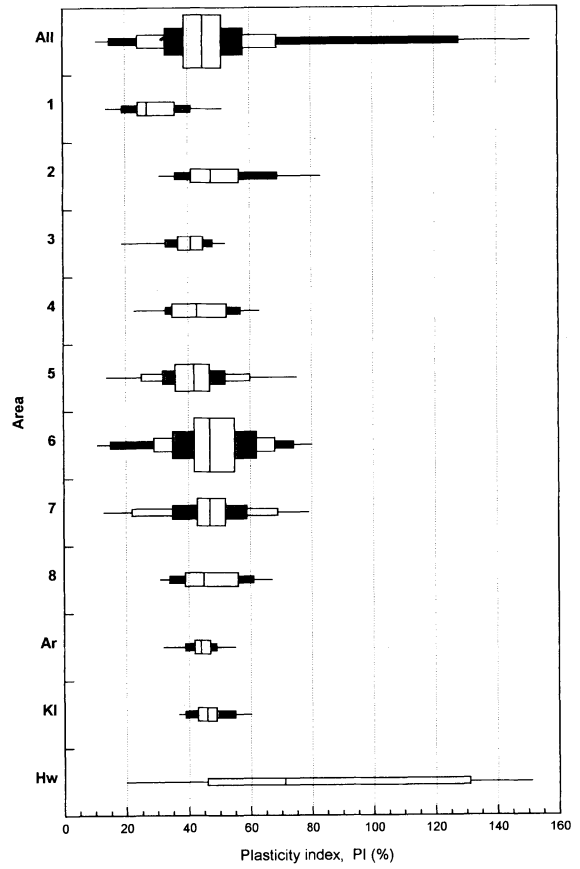

Figure 6.6 Box and Whisker plot: Plasticity index, PI (%).

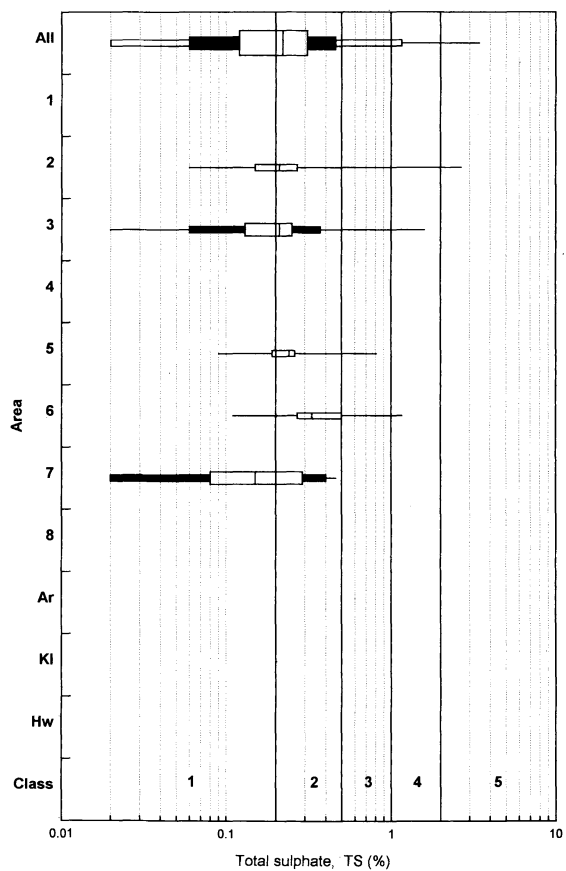

Figure 6.8 Box and Whisker plot: Total sulphate, TS (%).

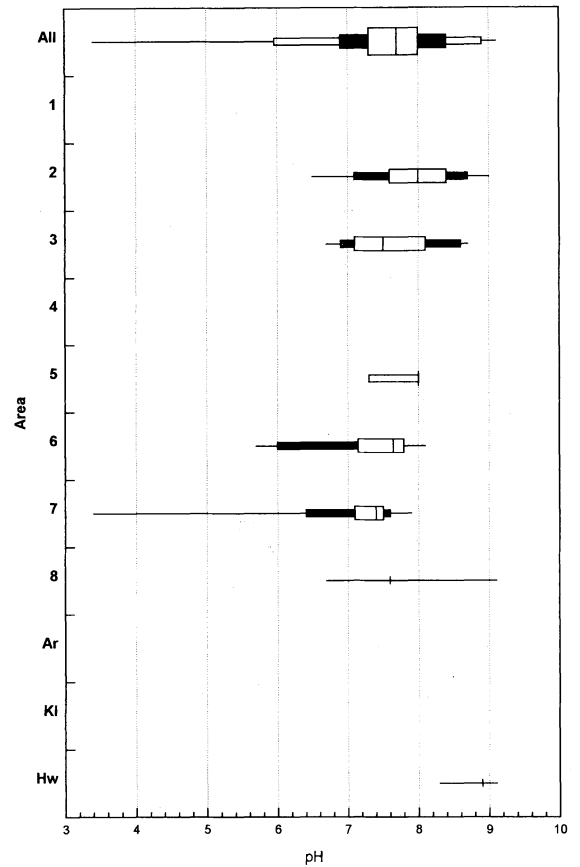

Figure 6.9 Box and Whisker plot: pH.

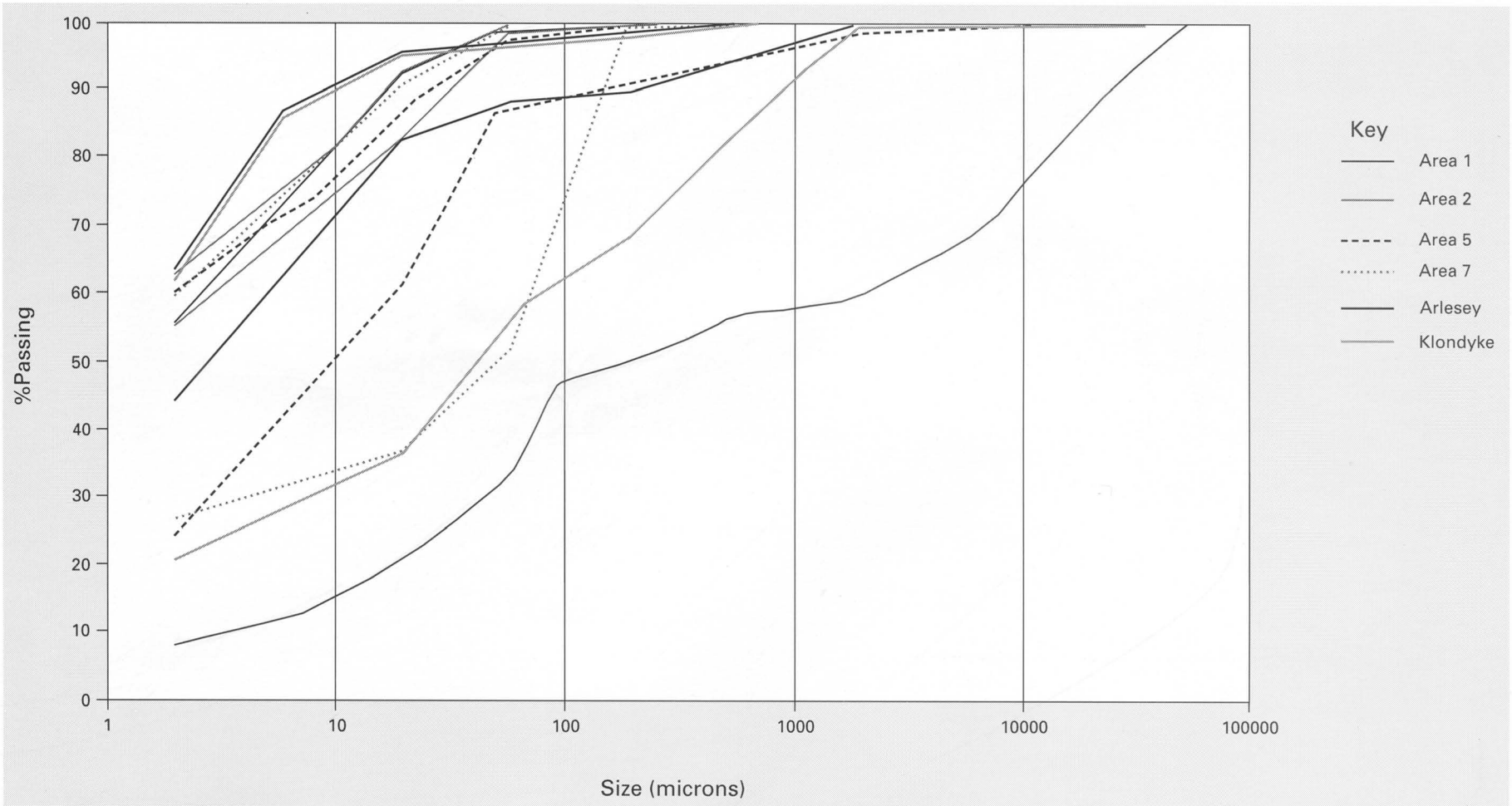

Figure 6.7 Envelope plot: Particle size grading (all data).

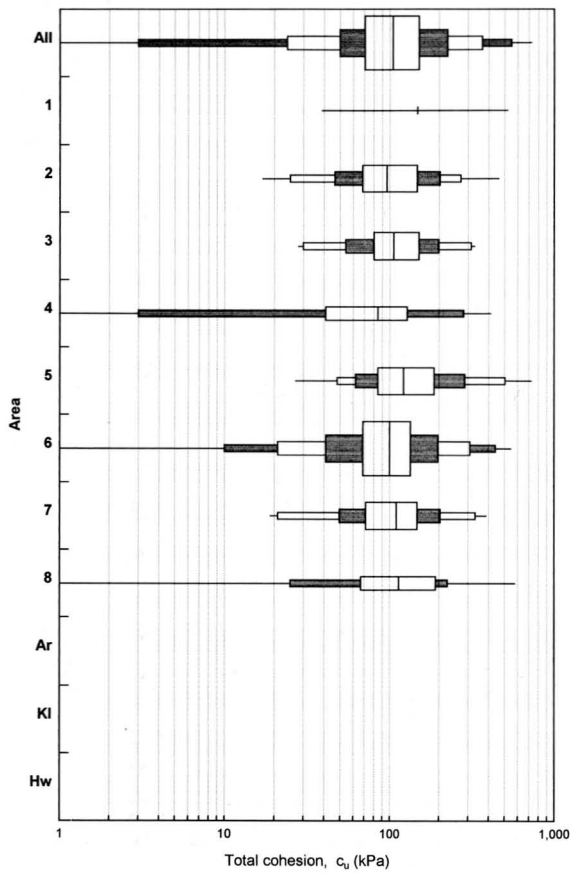

Figure 6.10 Box and Whisker plot: Total cohesion, c_u (kPa).

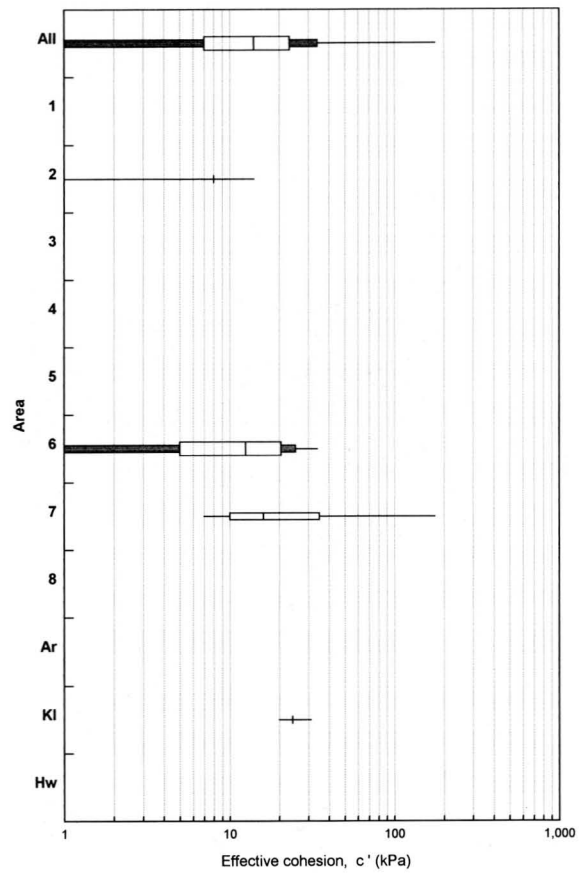

Figure 6.11 Box and Whisker plot: Effective cohesion, c' (kPa).

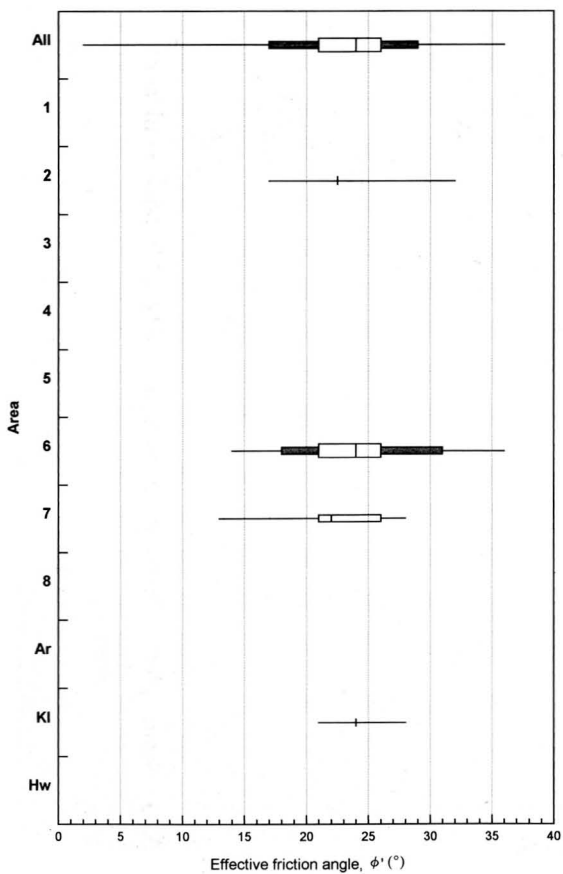

Figure 6.12 Box and Whisker plot: Effective friction angle, ϕ' (degrees).

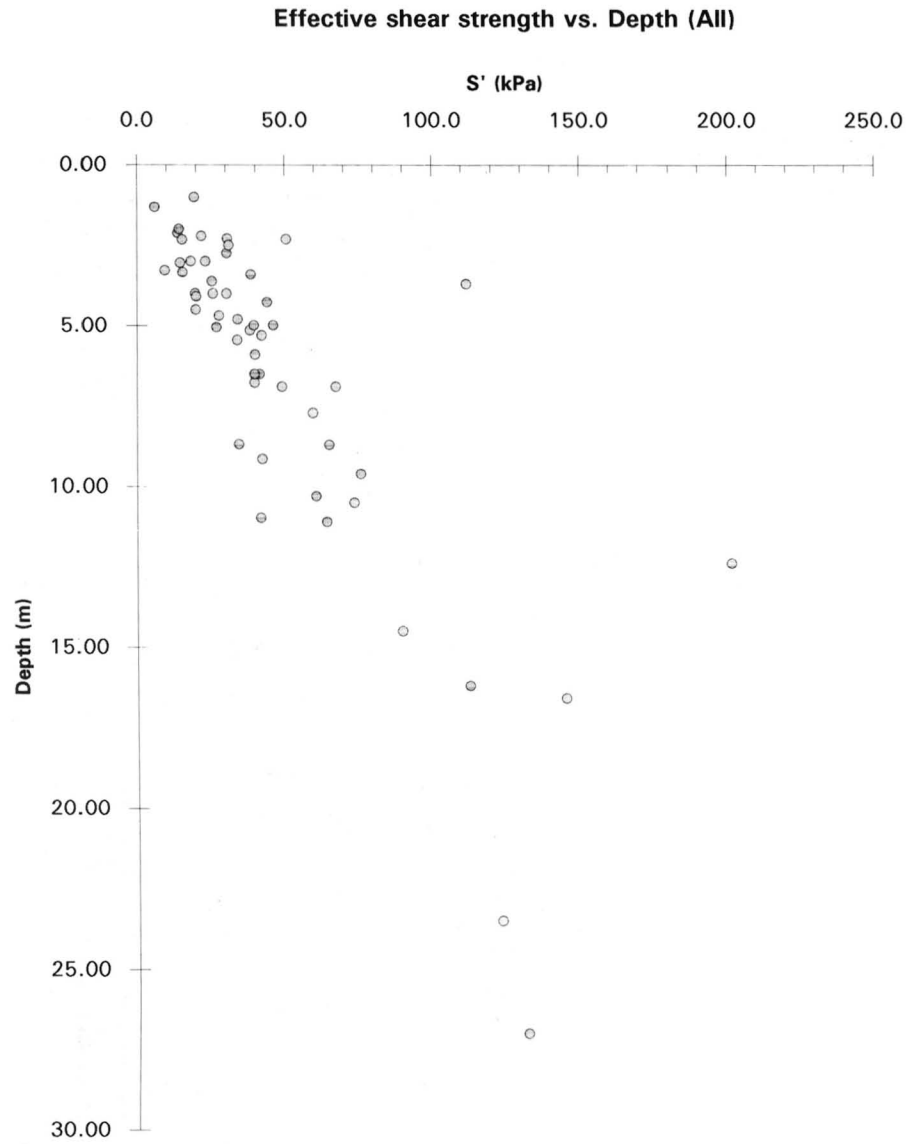

Figure 6.13 Scatter plot: Effective shear strength vs. Depth (Triaxial — all data).

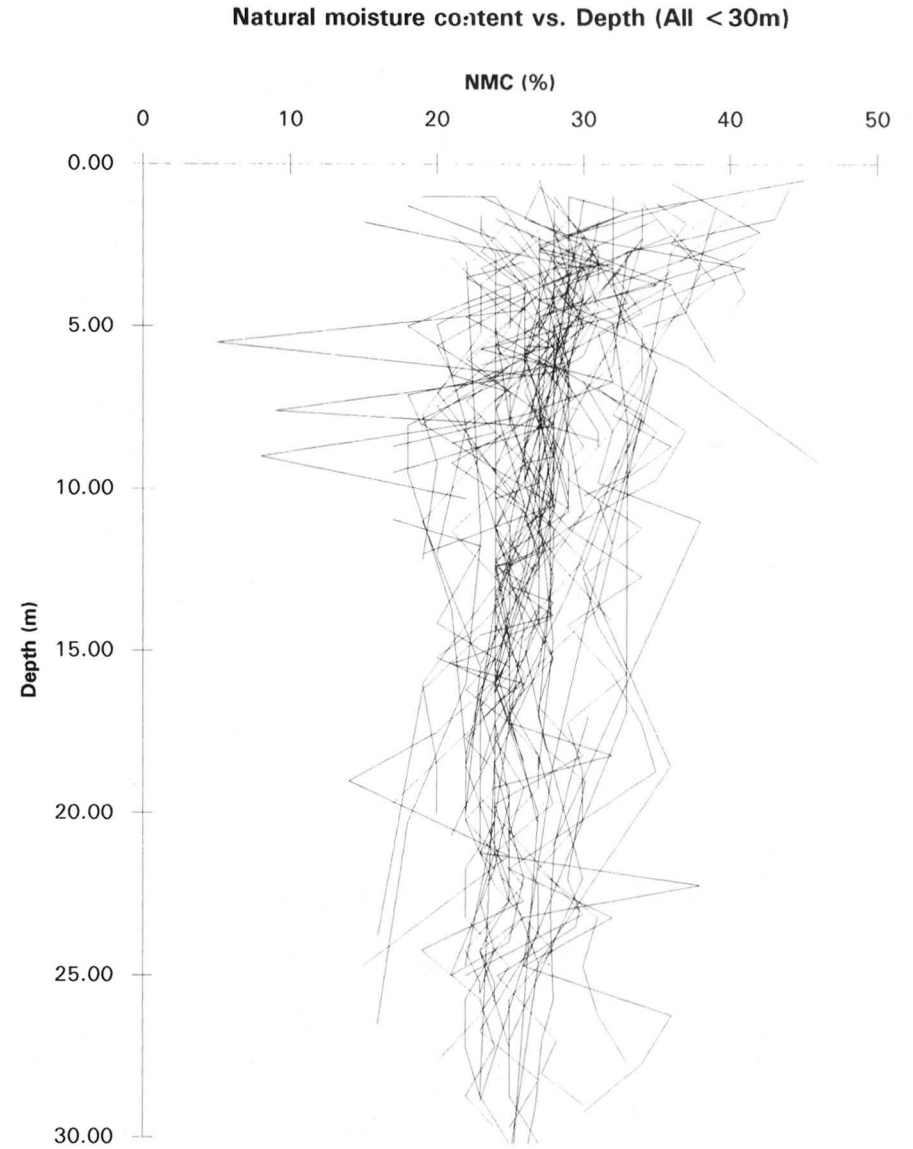

Figure 6.14 Line plot: Natural moisture content, (%) v Depth (m).

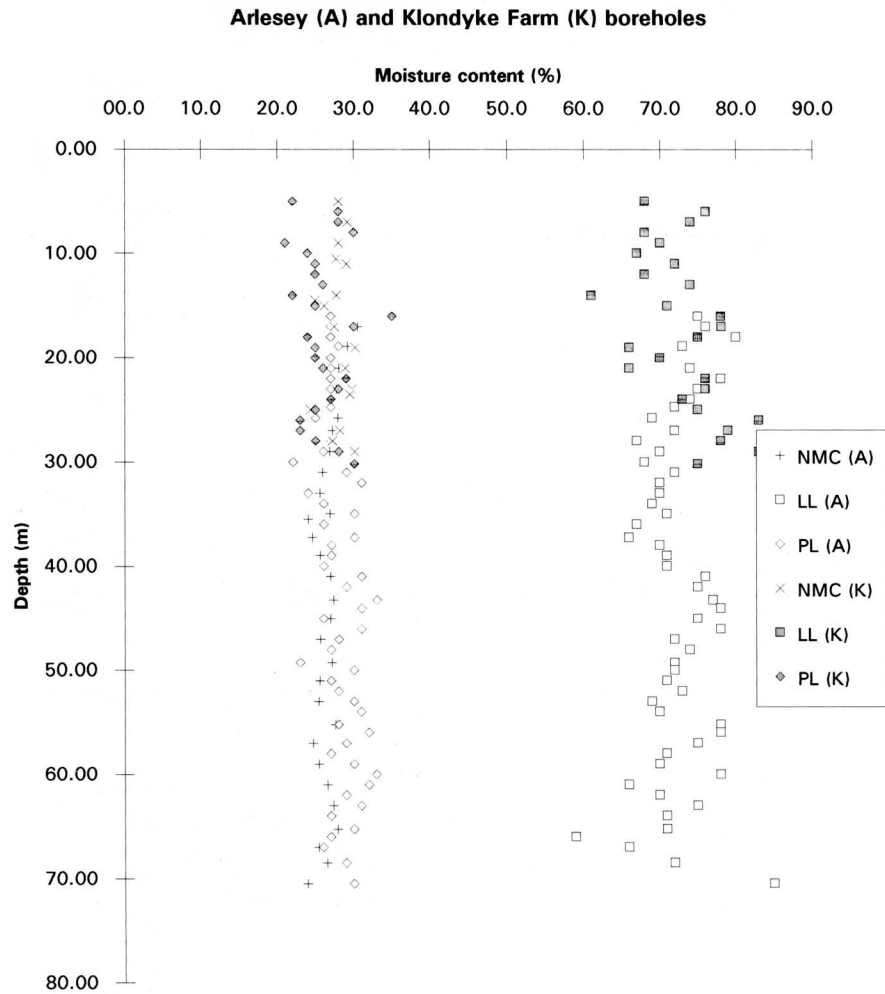

Figure 6.15 Line plot: Liquid limit, Plastic limit, natural moisture content, w (%) v Depth (Arlesey and Klondyke).

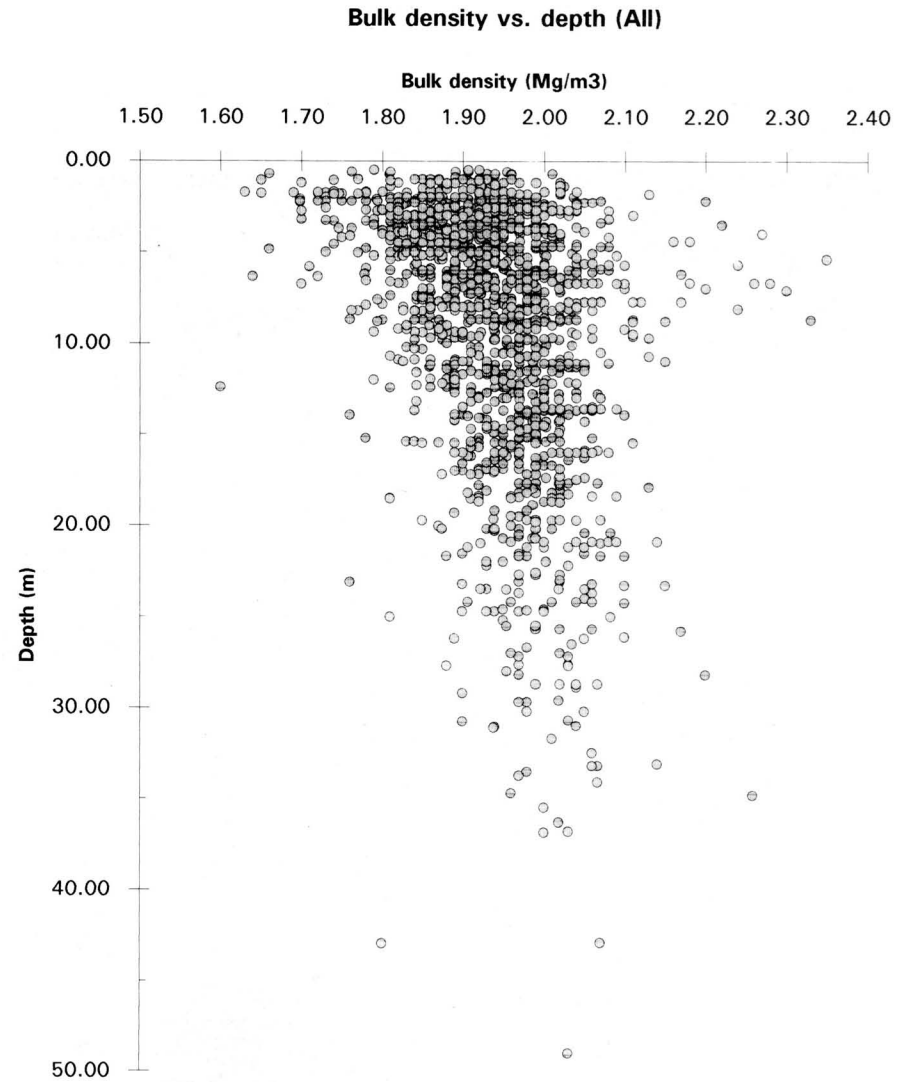

Figure 6.16 Line plot: Bulk density, γ_b (Mg/m³) v Depth (m).

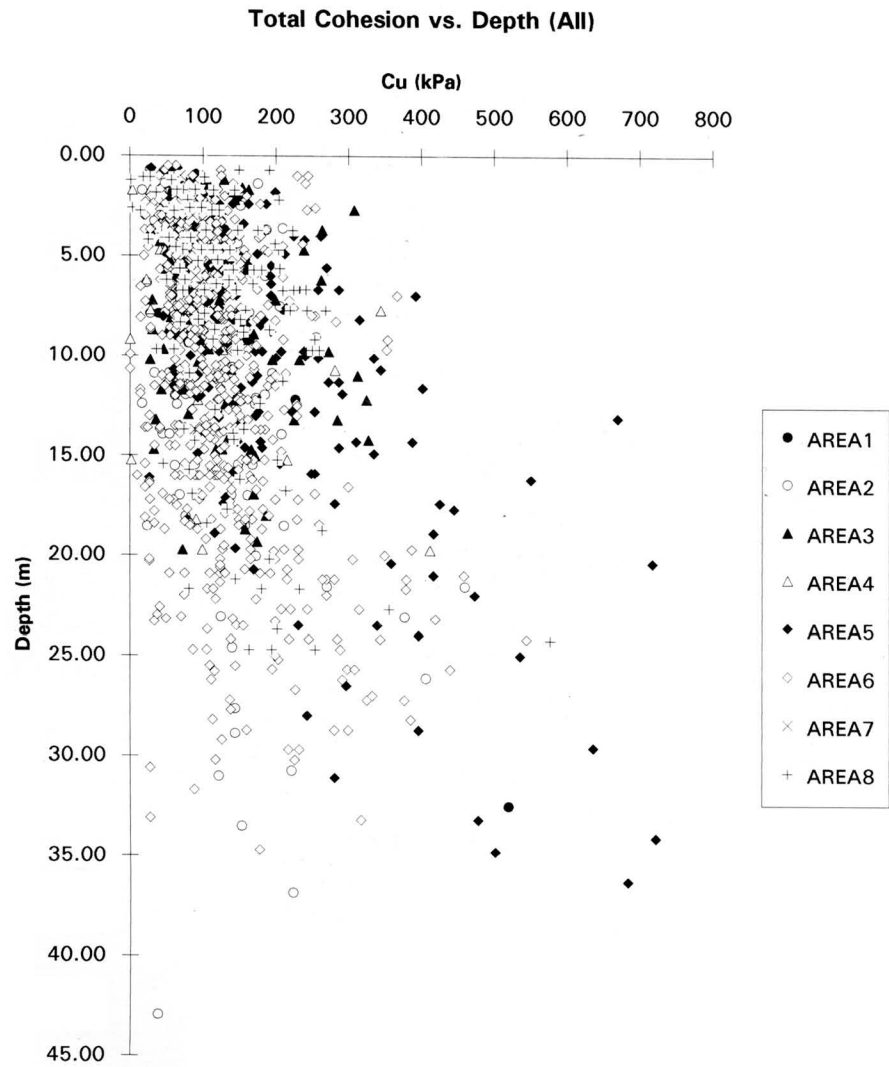

Figure 6.17 Scatter plot: Total cohesion vs. Depth (Triaxial — all data).

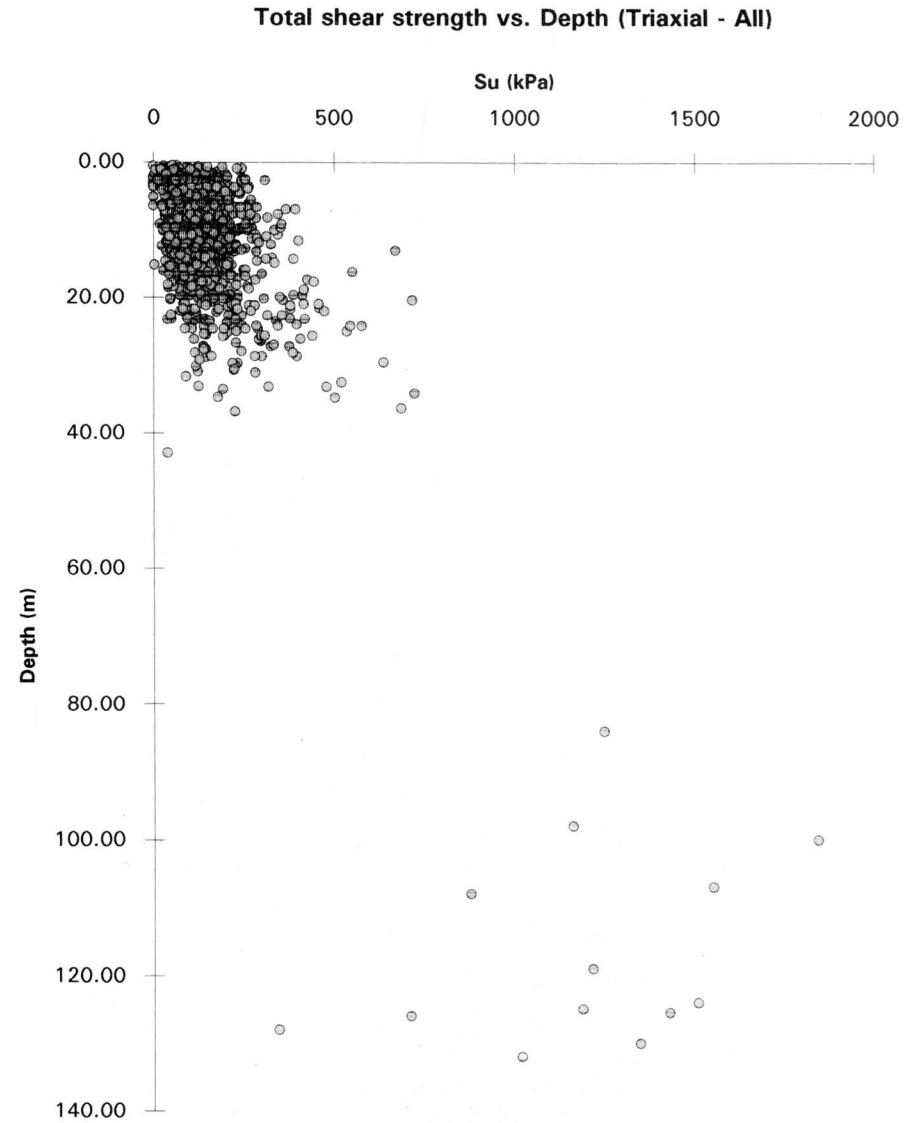

Figure 6.18 Scatter plot: Total shear strength vs. Depth (Triaxial — all data).

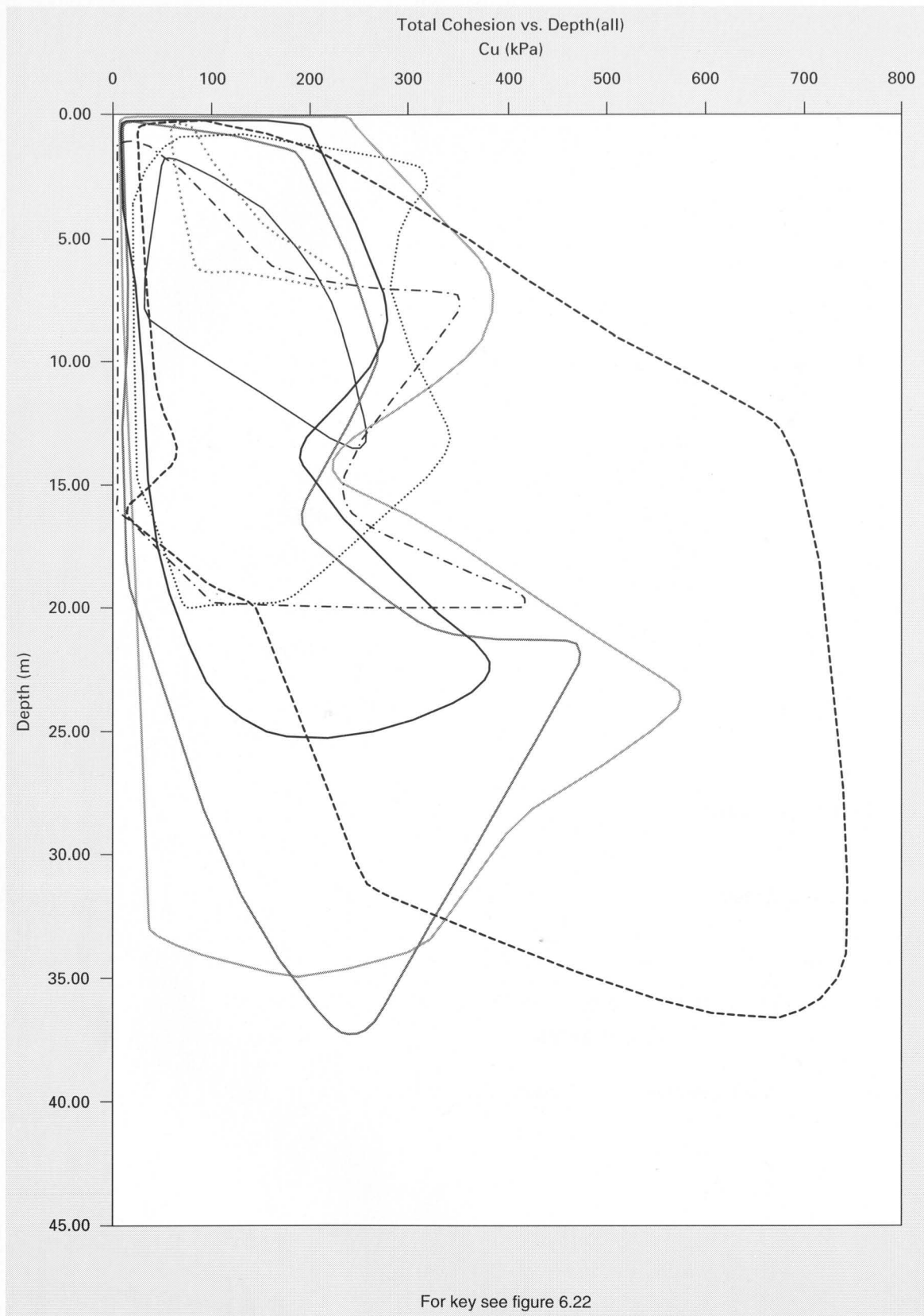

Figure 6.19 Envelope plot: Total cohesion vs. Depth (by Area).

Bulk density (measured) vs. bulk density (calculated) - (All)

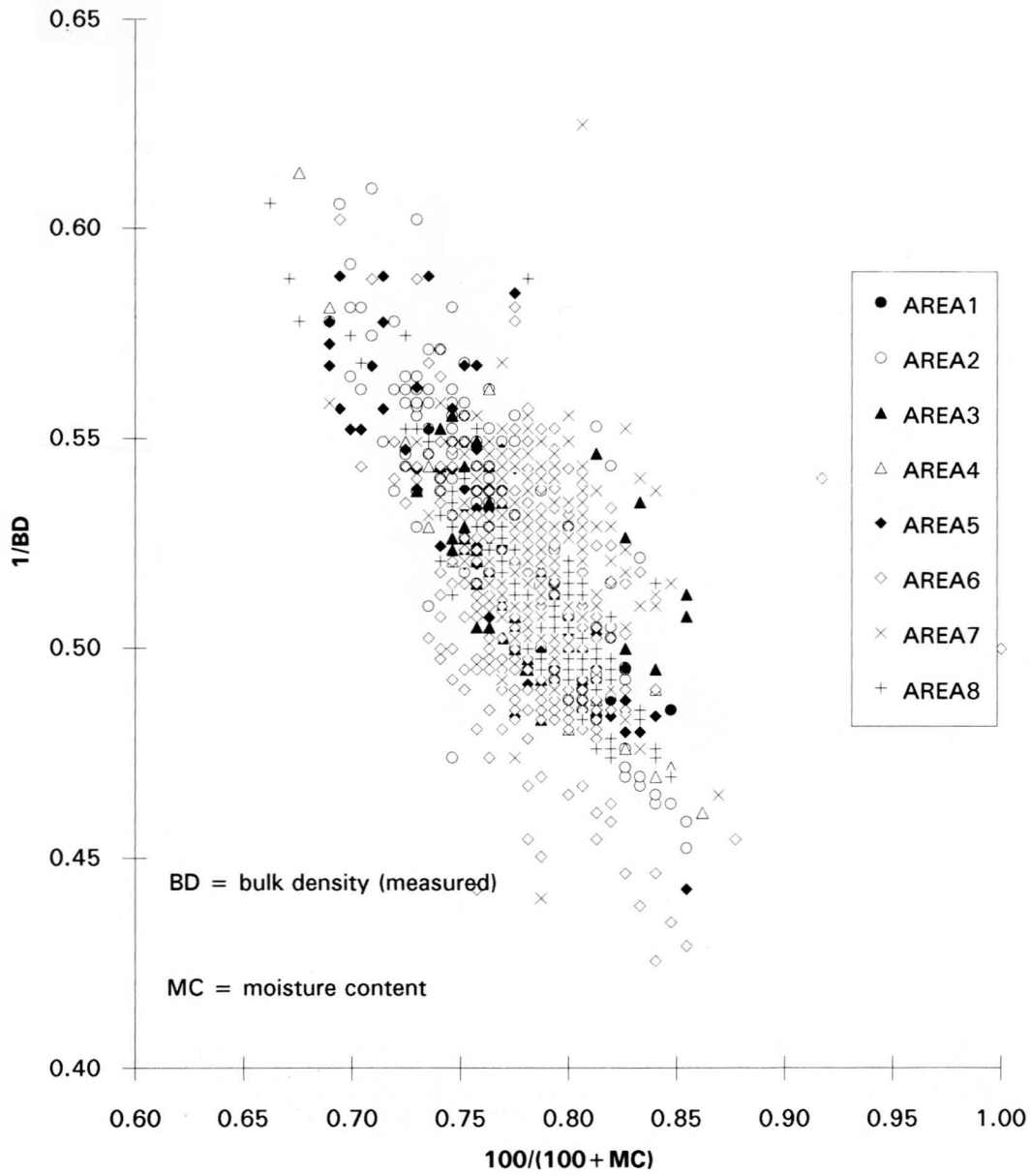
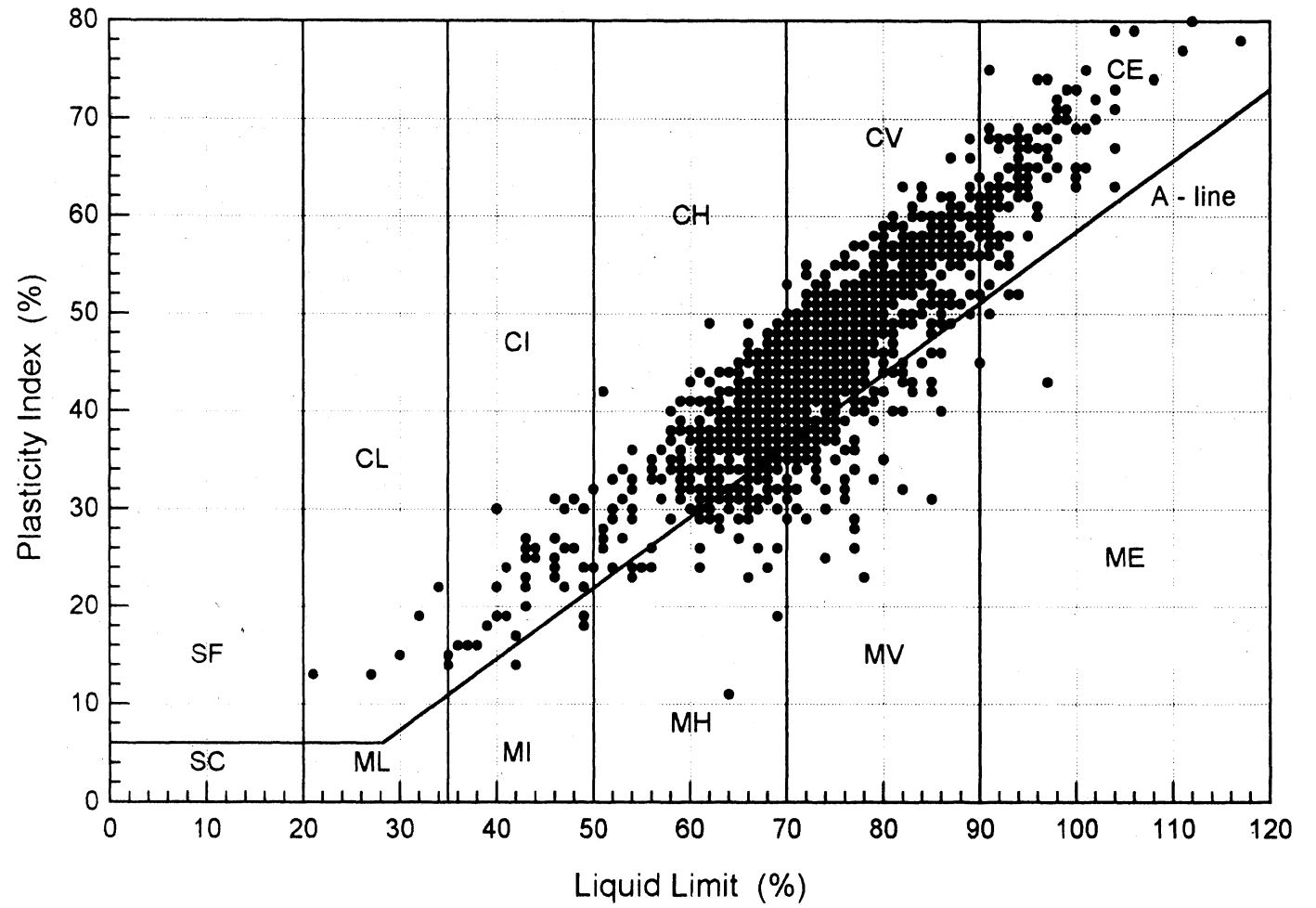

Figure 6.20 Scatter plot: Bulk density, measured vs. calculated (from moisture content).

Figure 6.21 Casagrande 'plasticity' plot (all data except Harwell).



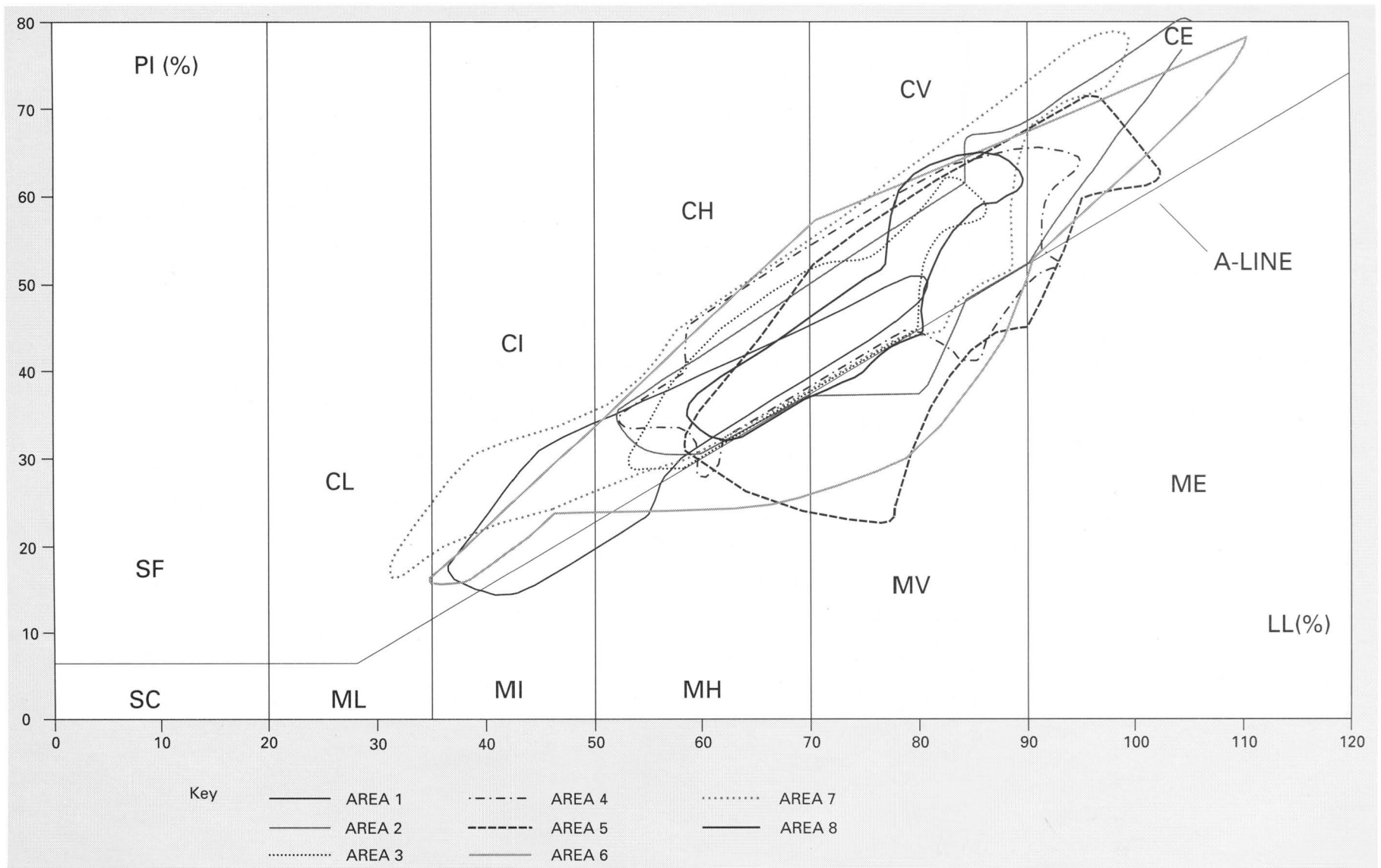
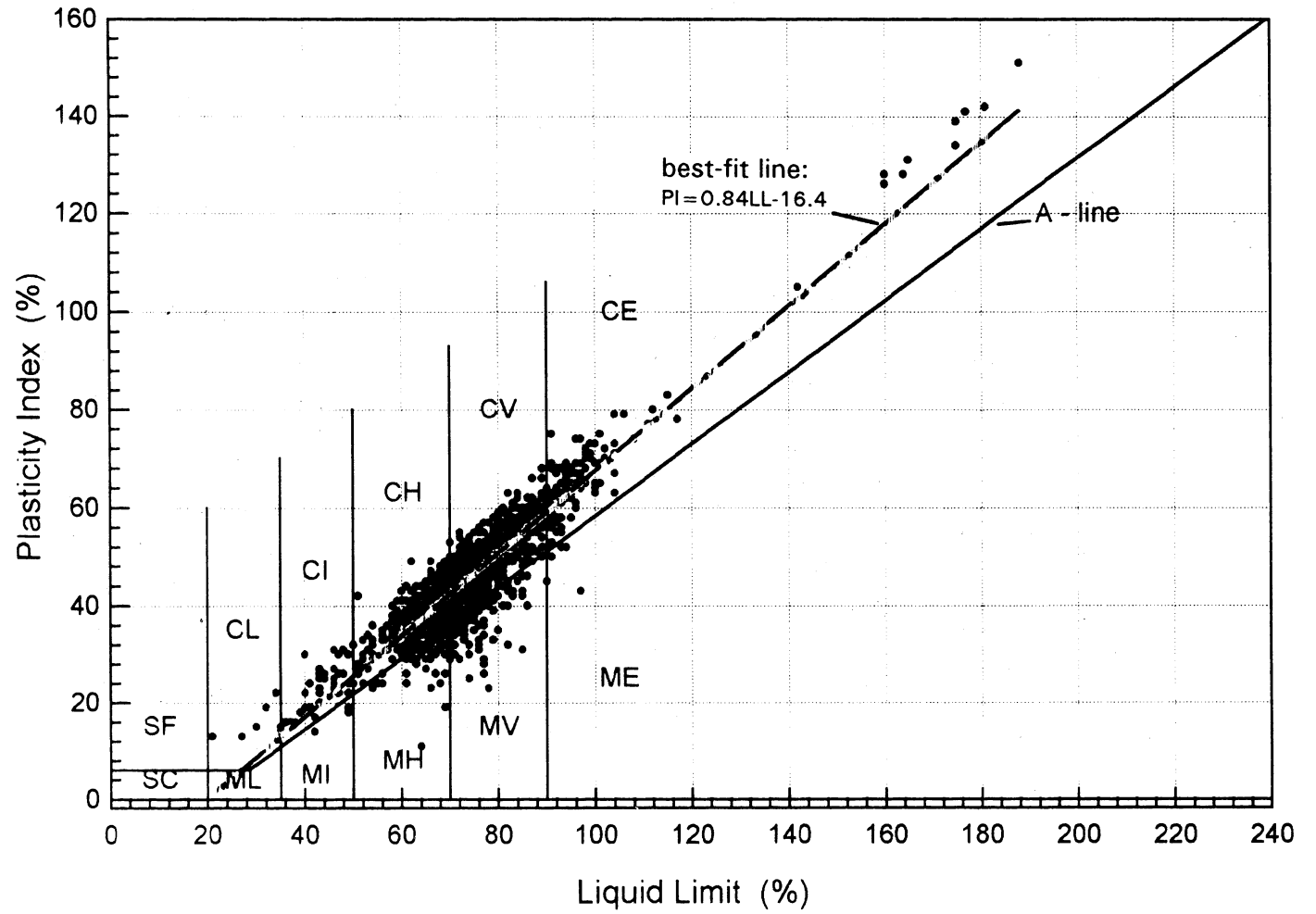

Figure 6.22 Casagrande 'plasticity' plot — area envelopes (all data except Harwell).

Figure 6.23 Casagrande 'plasticity' plot (all data).



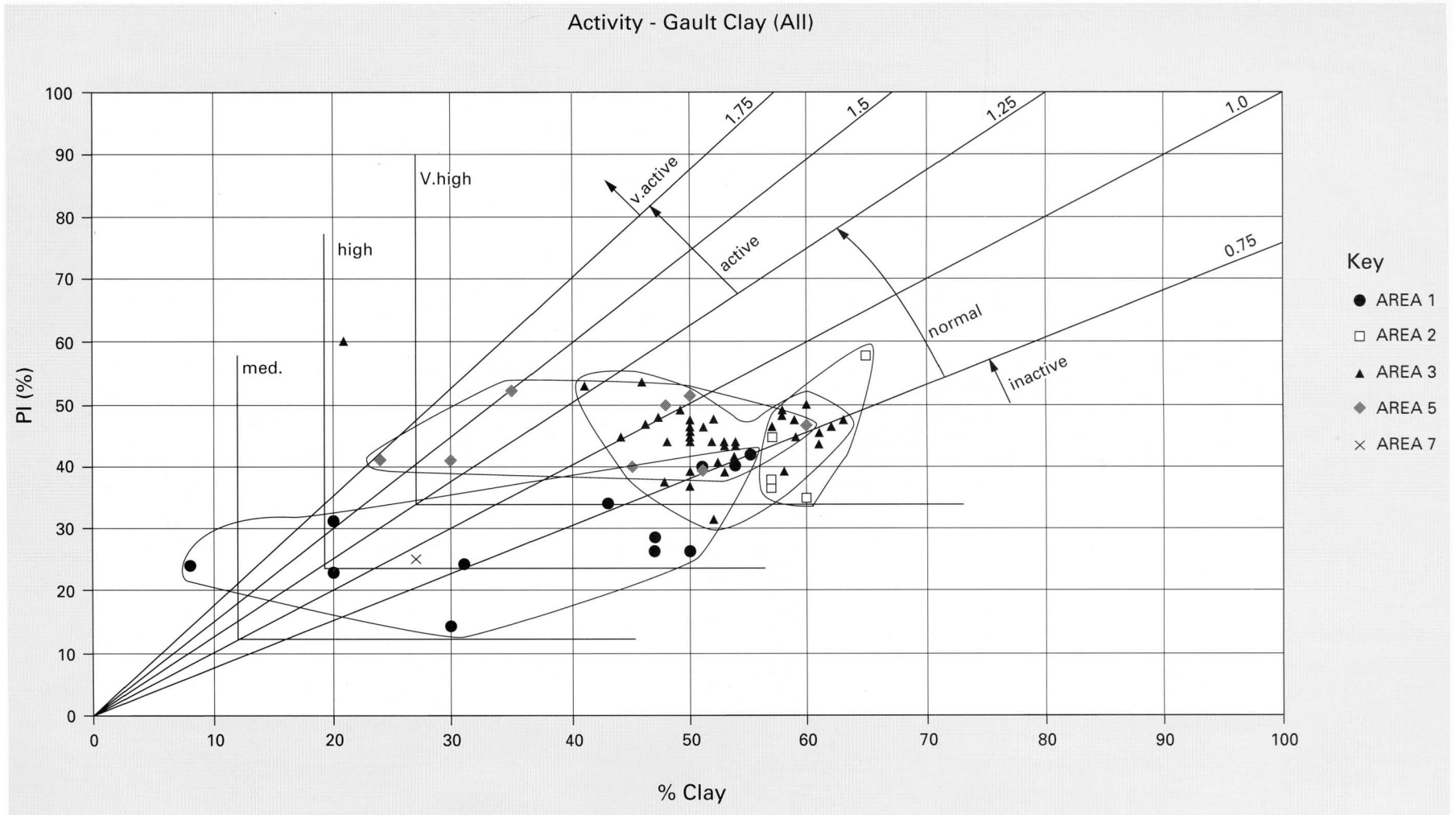
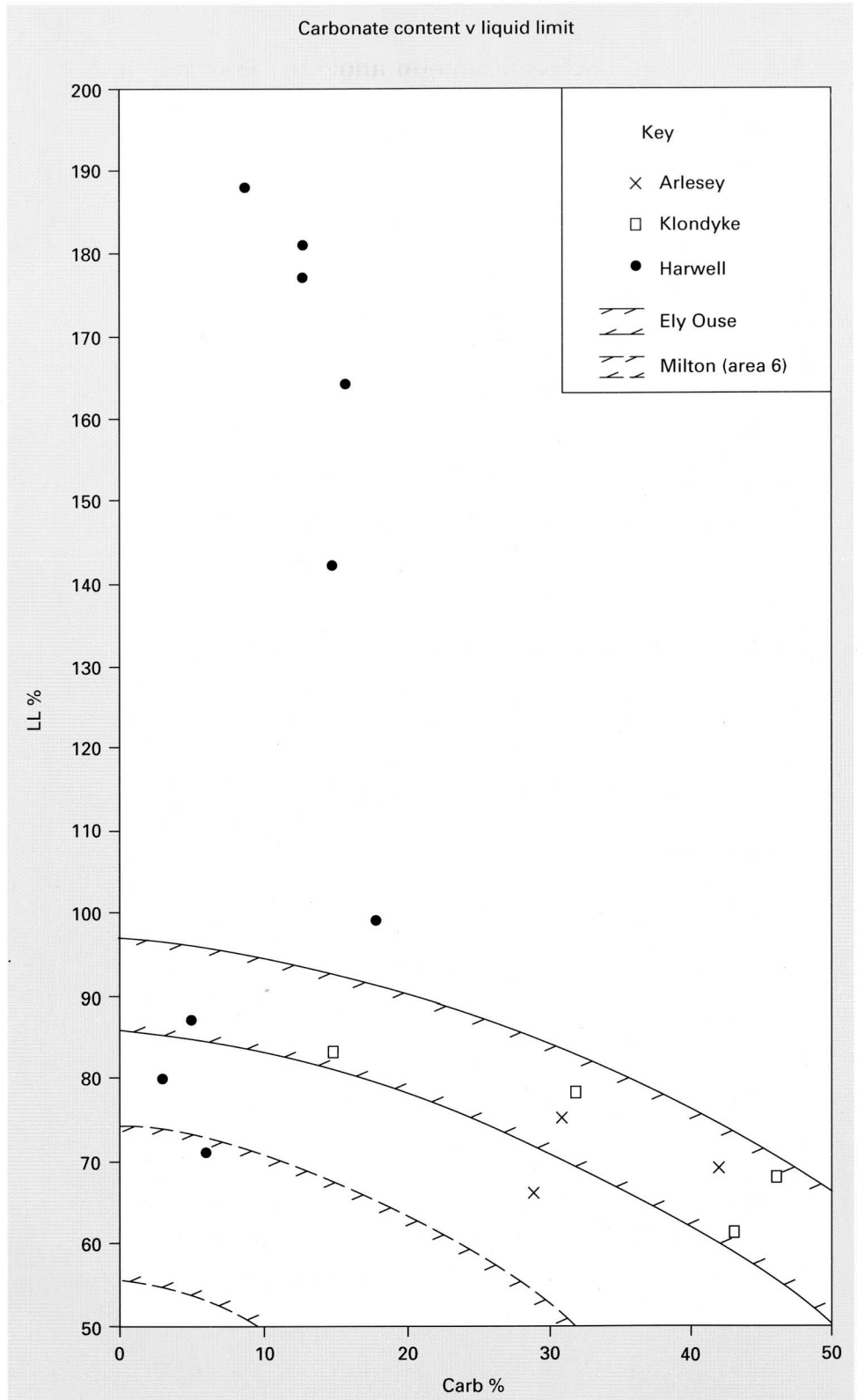

Figure 6.24 Skempton 'activity' plot (all data).

Figure 6.25 Scatter plot: Carbonate content vs. Liquid limit (Arlesey, Klondyke Farm and Harwell).



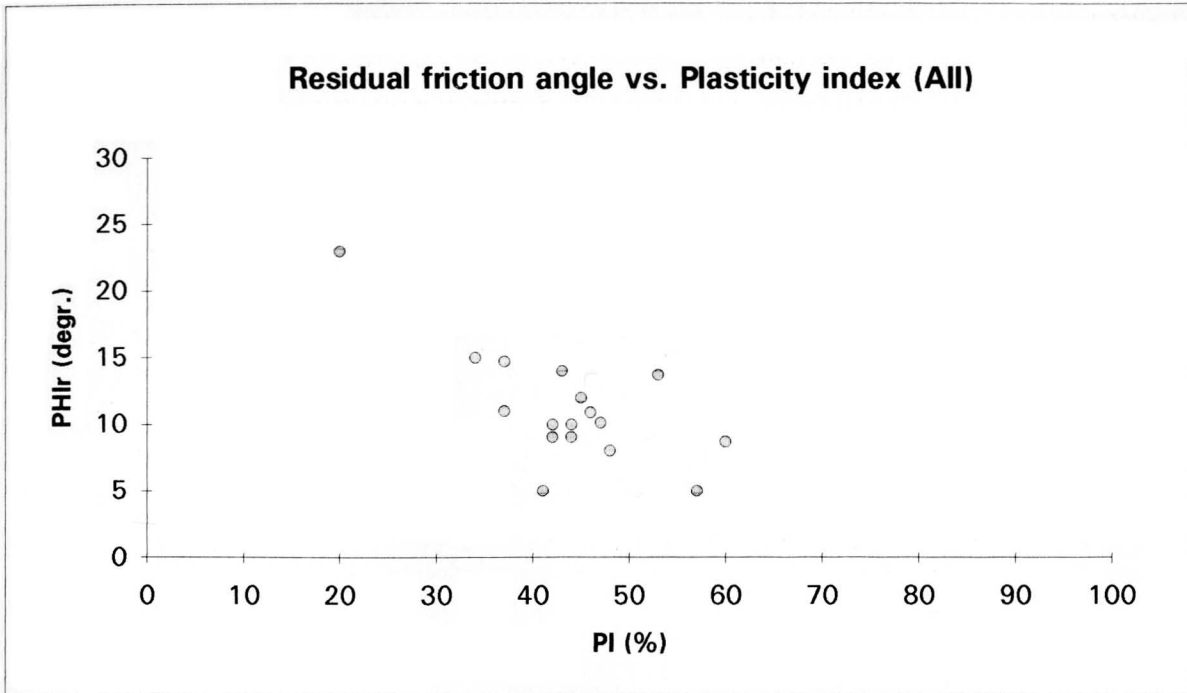

Figure 6.26 Scatter plot: Effective residual friction angle vs. Plasticity index (All).

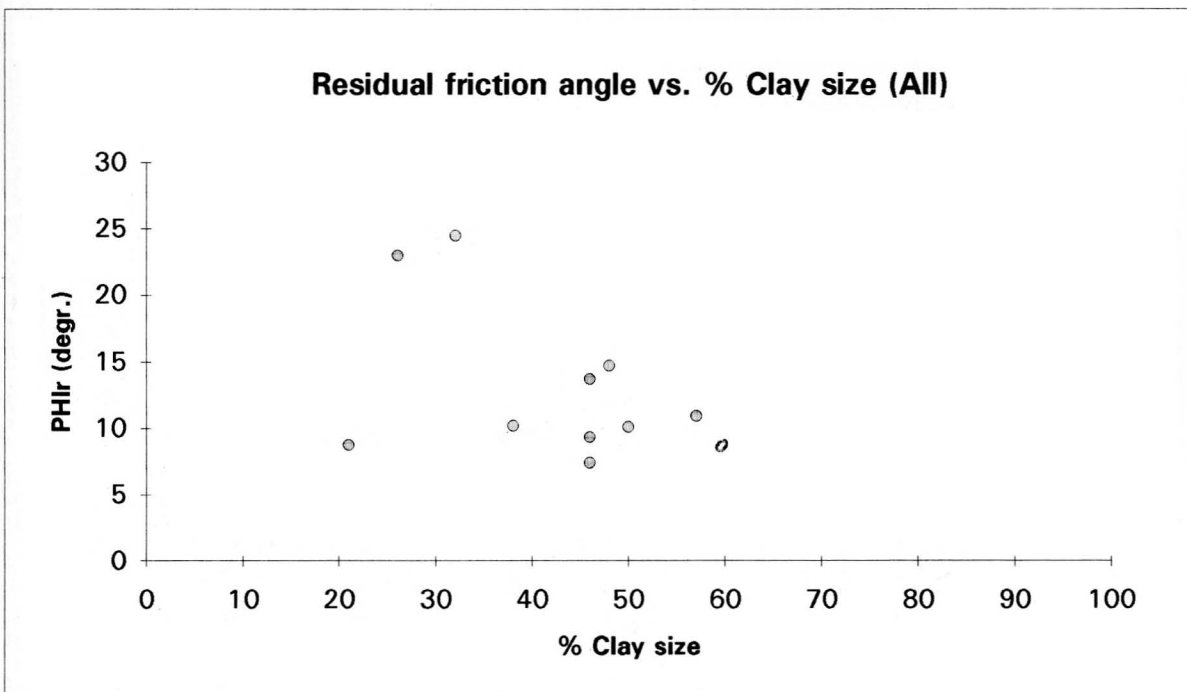

Figure 6.27 Scatter plot: Effective residual friction angle vs. per cent Clay size (All).

7 Groundwater considerations

The hydrogeology of mudrock formations has a significant influence on its engineering behaviour and the regional groundwater system. A review of the hydrogeology of the Gault clay and adjacent formations was given by Fenwick (1994). Heterogeneity, particularly fracturing, is a significant control on groundwater flow through mudrocks because flow through the matrix is extremely slow (Plate 2). The near-surface hydrogeology of the Gault clay is strongly controlled by its level of disturbance and degree of weathering; thus statistical analysis of locally measured hydraulic properties may not give a representative picture of regional values. Also, it is important to measure in-situ hydraulic conductivity to assess bulk permeability and to define the significance of groundwater sample chemistry which is dependent on the method of abstraction of the sample. Profiles of natural groundwater chemistry can be useful in helping to evaluate groundwater flow through mudrocks.

7.1 POROSITY AND PERMEABILITY

Mudrock porosity is dominated by small, planar pores, of less than $1\ \mu$ in size. Mudrocks normally have had a high porosity and low permeability from deposition, generally with little subsequent development of a diagenetic porosity (Alexander et al., 1987). In the Gault and Upper Greensand porosity is dominated by intergranular pores. But fractures and, in the Upper Greensand, diagenetic voids are likely to be significant in terms of their bulk permeability. Cripps and Taylor (1981) found that the porosity of the Gault varied between 31% and 48%, the higher values being derived from published dry density and specific gravity values. This agrees well with the values calculated during this project from values of specific gravity and dry density in the project database. Values ranged from 31.5% to 48.0%, though one value of 52.9% was calculated from a particularly low bulk density sample. Alexander (1983a) stated that porosity ranges from 35% to 40% in the Upper Greensand.

At Harwell Brightman et al. (1987) found the permeability of Gault clay to be $8.3 \times 10^{-12}\ \text{ms}^{-1}$. Alexander (1983a) stated that the hydraulic conductivity of the Upper Greensand in the same region ranged from 1×10^{-9} to $1 \times 10^{-6}\ \text{ms}^{-1}$, and its regional range was 1.3×10^{-8} to $1.5 \times 10^{-7}\ \text{ms}^{-1}$. Laboratory hydraulic conductivity values tend to be lower than field values because the contribution of fissure flow in the field is absent in the laboratory. At Harwell Brightman et al. (1987) found the specific storage of Gault clay to be 2.3×10^{-5} , and that of the Upper Greensand to be 1×10^{-6} . Permeability was determined during oedometer and triaxial testing of material from the Klondkye Farm and Arlesey Boreholes (Chapter 6) and the results are quoted in Table 6.4.

The depositional history of a material is important because rapidly changing palaeogeography results in very variable lithologies and heterogeneous flow paths with vertical and horizontal variability in porosity and hydraulic conductivity (Alexander, 1983a). In the Gault and Upper

Greensand these features are not extreme, but variations in particle size distributions and pore morphologies in these formations influence groundwater fluxes passing through them. Marine and non-marine environments affect hydrochemistry differently, and salinity gradients can cause the migration of water even in the absence of other gradients (Alexander, 1983a).

The diagenetic processes which have affected the Gault and Upper Greensand have significant implications (Milodowski et al., 1982). Diagenesis is important in determining the chemistry and the orientation of the diagenetic mineralisation in pores and this has a particularly significant influence on matrix permeability.

Milodowski et al. (1982) described the different types of pores in the Upper Greensand at Harwell. The fossil porosity consists of large pores ($20\text{--}50\ \mu\text{m}$). These pores are often filled with authigenic mineral growth and tend to be isolated, unless their walls are breached. Consequently they do not contribute significantly to groundwater movement. Intragranular pores, those within grains, are a minor, insignificant, component of total porosity, though they are hydraulically connected. Intergranular pores, often less than $1\ \mu\text{m}$ in size, are the main source of porosity. Diagenetic pores are usually large ($5\text{--}100\ \mu\text{m}$), interconnected, and are significant to groundwater flow. They are always lined with opal CT, which is sometimes covered with zeolite growths and clay bushes up to $10\ \mu\text{m}$ in size. Intergranular fractures do not contribute, significantly to overall porosity, but they may be important routes for water movement; some of these are cemented by pyrite, while others are open and clear.

The porosity of the Gault is similar to that of the Upper Greensand though localised diagenetic voids are only ever found in the upper Gault (Milodowski et al., 1982). Larger fractures are more common in the Gault, and can increase its permeability by over an order of magnitude. Compaction has produced a closely-packed sediment fabric throughout. Intergranular porosity is both laminar and equant in the upper Gault, but mainly laminar in the lower Gault (Milodowski et al., 1982). This may cause the ratio of vertical to horizontal permeability to vary through the unit.

The depth of weathering will vary with clay mineral composition, site location and site conditions, such that local conditions largely control the hydrogeological and hydrochemical environment of the near-surface mudrock (Alexander et al., 1987). Hence regional assessments based on the premise of 'uniform' conditions are not well supported by local shallow investigations. The effects of chemical weathering on British mudrocks is usually confined to the top 3 m to 5 m and rarely extends to a depth of 10 m in unfractured masses (Alexander et al., 1987). Major structural factors, or impersistent lithological features, will enhance in-situ permeability and facilitate the movement of fluids into the rock mass, and cause local modifications of flux-patterns (Alexander et al., 1987).

Periglacial disturbance results in higher bulk permeability near to the surface, cryoturbation shears tending to be more randomly oriented and more steeply

inclined than low-angle solifluction shears (Newman, 1985).

Chinsman (1972) found that permeability, and its variability, in the Gault clay decreased with increasing load. This effect was irrespective of its state of weathering or disturbance and he attributed it to the closure and constriction of fissures. Also, fissure spacing was observed to increase with depth in trial pits in the Gault. Free moisture was sometimes evident from fractures in trial pits, indicating that they are a groundwater flow path (Plate 2). He also observed silt-filled wedges and veins down to the top 2 m of unweathered Gault, which would increase near-surface permeability.

The reduction of stress on excavation of a fissured clay will cause the fissures to open, allowing a more rapid distribution of pore water pressure, so that the pore water pressure adjustment to long-term equilibrium conditions will occur more rapidly. Pore water pressure decreases with excavation, though there appears to be a time-lag between the two (Chinsman, 1972). There may even be drawdown behind a Gault clay cutting, since pore water pressure change seems to be a function of both vertical and lateral stress changes.

In those zones of the Gault exhibiting high permeability some water content changes may occur during typical construction periods, especially under low levels of stress. High in-situ permeability also allows seepage and rapid softening during water impoundment (Chinsman, 1972).

7.2 PERMEABILITY HETEROGENEITY

Fracturing in the Gault is common and is frequently open. It is divided into two types by Milodowski et al. (1982). Firstly, large aperture (1 mm–5 mm) open fractures across core, with clay particles on their flanks orientated parallel to them; these may be natural joints or may be drilling-induced fractures. Secondly, microscopic fractures exist which are several millimetres long and are often lined with authigenic pyrite. Tectonic discontinuities could be included as a third fracture type. These are often slicken-sided and are common in the Weald, where tectonic effects are more pronounced, than further north. Glacio-tectonic faults and disturbance may be present in the more northern Gault outcrops, where it may have been affected by overlying, mobile ice during the last Ice Age. Fissures from these two processes may be quite extensive and therefore significant in hydrogeological terms. Fractures in the Upper Greensand are sometimes infilled, which reduces their impact on bulk permeability (Milodowski et al., 1982).

Other components affecting the permeability of the Gault are silt veins, bands of shattered siltstone, phosphatic nodules, pyrite nodules, selenite crystals and occasionally thin seams of silt-size and sand-size particles between fissure faces. These minor variations will be reflected by in-situ permeability (Chinsman, 1972).

Overconsolidated clays, such as Gault clay, usually give a lower magnitude and faster rate of settlement than predicted from tests on laboratory samples. This may be attributed to considerably greater mass permeability in the field than is measured from samples. Chinsman (1972) found that the field permeability of the Gault can be at least an order-of-magnitude greater than laboratory permeability. He attributed this to the lack of homogeneity on the larger scale mainly as a result of fissuring, three

dimensional drainage and anisotropic stress conditions in-situ.

7.3 PORE WATER CHEMISTRY

At Harwell, where the Gault is over 95 m below ground level (bgl), the dominant pore water chemistry comprises Na, Cl and SO₄ (Brightman et al., 1985). At Milton where the Gault is found at a shallower depth (2.8 m bgl), it is dominated by Ca, Mg and SO₄, with significant Na and Cl. At a site on the Upper Greensand outcrop to the north of Harwell, Brightman et al. (1985) found that the Upper Greensand groundwater chemistry is dominated by Na, Cl and HCO₃, with significant SO₄, although the solutions are not very saline.

Stable isotope results from the relatively low salinity waters of both the Upper Greensand and the Gault are representative of recent local meteoric recharge mixed with small proportions of saline groundwater (Alexander et al., 1987; Brightman et al., 1985). The stable isotope results also correlate with the depths from which the individual samples were obtained.

Alexander et al. (1987) found that increased salinity with depth coincided with locations of postulated downward vertical flow. Whereas, where there was thought to be vertical upward groundwater movement, differences in composition are associated with distinct horizons, which could be a result of changes in migration direction over time.

In low-flow environments with minimal hydraulic gradients, it is differences in fluid chemistry, leading to the processes of osmosis and diffusion, which are the major cause of solute migration rather than fluid movement itself (Alexander et al., 1987). This migration will be further restricted by the considerable potential of mudrocks for ion-exchange and sorption reactions.

The oxidation of pyrite, which is frequently found in Gault clay, is enhanced by microbial breakdown, and could result in acidic pore waters, which would enhance leaching and the transport of pollutants, as well as locally increasing porosity and permeability by the dissolution of unstable phases en route (Alexander et al., 1987; Milodowski et al., 1982). However, calcite in the Upper Greensand and upper Gault would buffer this, minimise its effect and reduce the solubilities of many ions. (Alexander et al., 1987). This also has implications for the transport of leachate from waste disposal sites.

Brightman et al. (1985) showed that a temperature rise would strongly influence solute transport; a 40°C rise in temperature on a clay sample caused a significant increase in dissolved concentrations, which has important implications for heat-generating waste. Large fractures will usually be lined with the detrital component phases through which they cut. In the Upper Greensand and Upper Gault these will be smectite, illite and opal-CT, and in the lower Gault illite and kaolinite, thus creating a significant potential for ion-exchange (Milodowski et al., 1982). Swelling clays, such as the vermiculite and smectite groups have a much higher specific surface area and therefore higher cation exchange capacities than non-swelling clays such as the illite or kaolinite groups (Alexander et al., 1987). Thus, the Upper Gault, in particular, has considerable potential for ion-exchange and sorption reactions with passing solutes. However, the diagenetic voids in the Upper Greensand and in parts of the Upper Gault are mainly lined with opal-CT and only minor

zeolites and smectite, and therefore, do not provide much ion-exchange capacity (Milodowski et al., 1982).

7.4 ROLE IN THE REGIONAL HYDROGEOLOGICAL REGIME

The Gault clay acts as a confining or leaky layer above several aquifers on which it rests unconformably. Groundwater level fluctuations in an aquifer will generally be lower for greater thicknesses of confining Gault, because of the dampened recharge response. Any deviations from this are usually attributed to abstraction effects though significant changes in hydraulic properties, such as faults, may impart smaller scale fluctuations (Alexander, 1983a). Alexander et al. (1987) found that the standard deviation of aquifer groundwater levels is a useful statistical measure of their variability.

The Lower Greensand is highly permeable but regionally very variable in thickness, and is sometimes absent (Alexander, 1983a). It has a restricted outcrop at Harlow, resulting in poor recharge potential, so that its deeper waters can be saline. This restriction of its groundwater movement suggests it is effectively confined by the Gault (Alexander, 1983a).

The Great Oolite underlies the Gault/Upper Greensand to the north and east of Bridport in south-west England. It is a fissured limestone with an abundance of springs at outcrop and is a significant aquifer for water supply. Where it

lies under the Oxford Clay its waters are non-potable and do not fluctuate seasonally more than a few kilometres from outcrop, and this could also be the case where it is overlain by the Albian (Alexander, 1983a). The Great Oolite has a higher head than the Corallian at Harwell, implying upward flow through the Oxford Clay (Alexander, 1983a). If there is a similar upward head gradient where it lies directly below the Gault/Upper Greensand, a similar situation could occur.

However, in the west of England the Gault becomes progressively siltier and passes laterally and vertically into Upper Greensand. Thus the overlying Gault/Upper Greensand in the south-west may be significantly permeable, and with a downward head gradient it could leak recharge to the limestone and dampen groundwater level fluctuations within it. Some outliers of Chalk lie on top of the Albian in this area and may contribute water to it in turn. Where the Gault/Upper Greensand is of very low permeability, this will highlight the low storage potential of the limestone and will amplify groundwater level variations, which can result seasonally in artesian conditions. (Alexander, 1983a).

The Gault is thus an important modifier of the regional hydrogeological regime. It restricts groundwater fluxes through it and therefore helps to control the recharge and discharge of adjacent aquifers. The Gault acts as an imperfect confining layer over underlying aquifers, and the Upper Greensand may locally act as a combined aquifer system with the overlying Chalk.

8 Implications for land-use and engineering construction

INTRODUCTION

The Gault clay does not have a large outcrop compared to many other geological formations. Historically there has been generally little construction on it other than isolated dwellings. It would appear that the problems it presented had been recognised and avoided if possible. In more recent times with increased population and more sophisticated requirements for transport, construction has had to move onto less tractable geological materials including Gault clay. The development of the motorway network since the 1960s and the associated development of housing, industry and retail premises has highlighted this problem. However, Gault clay can offer reasonable foundation conditions for structures if suitably designed foundations are used, which take into account the geotechnical properties of the material.

The problems posed by Gault clay are largely a result of its geological history and mineral composition especially the presence of smectite clays. High smectite content may increase plasticity, decrease strength, cause large volume changes with moisture content variation, high swelling pressures, low angles of internal resistance and low residual strength. The smectite content and plasticity data from Arlesey, Klondyke Farm and Shaftesbury show that as the smectite content increases so do the liquid limit and plasticity values (Figures 8.1 and 8.2). The differences between the boreholes may be due to modifying effects of local mineral variation, to regional variation or to systematic experimental error. The relationship between depth, Atterberg limits and smectite content for samples from the Arlesey borehole are given in Figure 8.3. This shows that the clay mineral assemblage determined by the height of the X-ray diffraction peaks changes down the borehole from a smectite/mica assemblage at the top to a kaolinite/mica assemblage at the bottom but the change is not reflected by any significant variation in the plasticity limits or plasticity index. However they do follow quite closely the smectite content, as determined by surface area measurement. Therefore, smectite content, derived from the determination of surface area is a much better indicator of plasticity of the material than clay mineralogy determined by X-ray diffraction.

8.1 SLOPE STABILITY

In Britain at the end of the last Ice Age, approximately 10 000 years ago, the downslope mass movement of material was an almost ubiquitous process. At that time the downslope slumping of waterlogged material in periglacial conditions (solifluction) was active over most of Britain, particularly in the 'soft rock' areas of clays and sands in the south and east. The result of this activity was to leave much of Britain draped in a mantle of fossil solifluction sheets and head deposits. Solifluction deposits may contain fossil shear surfaces capable of reactivation if the stress conditions alter adversely. Since that time of intense activity further sliding has taken place as reactivations of earlier slides and as first time failures.

Ancient and recent landsliding have been recognised, and in some areas mapped, throughout the outcrop of the Gault. The review of research into landsliding in Great Britain, commissioned by the Department of the Environment (Anon, 1987a), attributed a landslide density of 5.00 to 9.99 slips per 100 km² to the Gault outcrop. However, the study was based on information from published sources and could not take into account landslides that were unrecorded or unrecognised. The bias towards underestimation was recognised by the authors and in the case of the Gault, where slips are mainly shallow and in rural areas, the underestimation may be considerable.

Landslides on Gault clay are often difficult to classify in detail since the characteristic topographic features which enable the type of movement to be identified frequently have degraded to an indistinct hummocky topography of coalesced slumps and flows with varying degrees of weathering. However, most movement is of shallow translational type with rotational elements at the back scarp and flows at the toe region. Multiple retrogressive rotational failures occur on some slopes. In some areas where Gault clay is part of a major, inland escarpment or coastal cliff then major, deep-seated, landslide complexes have developed as at Folkestone Warren near Dover and at Ventnor on the Isle of Wight.

Major landslides are usually easily seen during geological mapping but shallower landslides on Gault clay may be difficult for the nonspecialist to identify and may be degraded beyond recognition by natural weathering and erosion processes. Agricultural activity can mask the surface expression of landsliding and ploughing can remove all surface traces in a few seasons, but below the depth of ploughing shear surfaces, capable of reactivation, will remain.

8.1.1 Causes of shallow landslides

Examination of the geological setting of shallow landslides in Gault clay show that the clay is frequently overlain by more permeable strata (Upper Greensand, superficial deposits) which, if water-bearing, will cause a spring line to form at the interface with the relatively impermeable strata below. Water issuing from the springs results in an increase of the pore water pressure in the material below, reducing its strength and, therefore, the stability of the slope. Thus, the landslides are a result of the coincidence of a clay lithology below water-bearing strata on a slope too steep for the strength of the material of which it is composed, under the prevailing hydrogeological conditions. Groundwater conditions in a landslide may be isolated from the underlying clay as a result of reduced permeability normal to the failure surface and the introduction of directional permeability along it (Chinsman, 1972). Pore water pressures thus may be practically independent of those in the undisturbed formation below. Groundwater levels in landslide material tend to fluctuate with high amplitude in response to rainfall events, implying the existence of perched water tables. Whereas, in weathered or unweathered Gault, the groundwater level

Figure 8.1 A plot of plasticity index and whole rock smectite content for samples from boreholes at Arlesey, Klondyke and Shaftesbury.

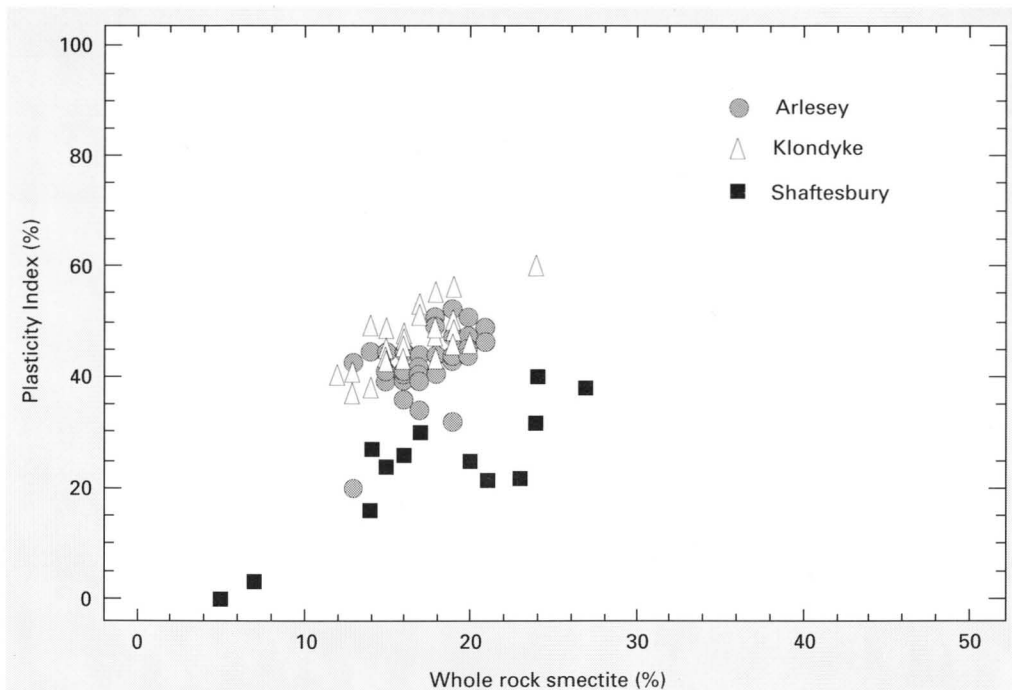
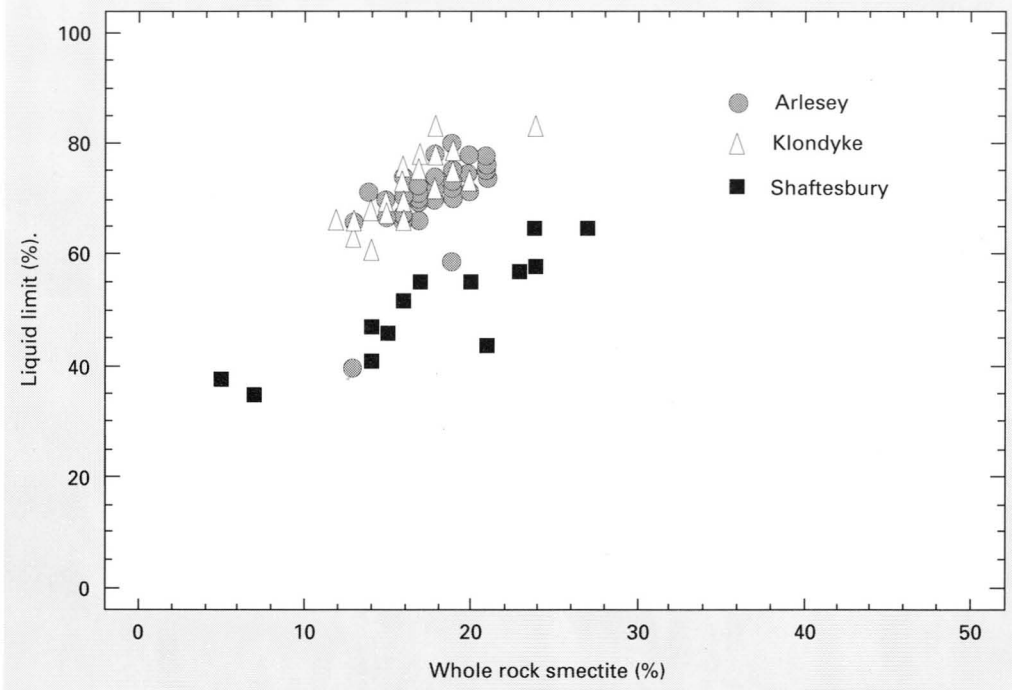

Figure 8.2 A plot of liquid limit and whole rock smectite content for samples from boreholes at Arlesey, Klondyke and Shaftesbury.



displays a far smaller amplitude, changing gradually with the seasons rather than rainfall events (Chinsman, 1972).

Local variations in water table levels and material properties make it difficult to predict a maximum stable slope angle for a lithology which forms a hill side but by using representative geotechnical test data and assuming the 'worst case' groundwater conditions, a first approximation can be calculated using the 'infinite slope' method (Skempton and De Lory, 1957).

The maximum stable slope angle for a lithology cannot be calculated unless the groundwater conditions are known. Groundwater levels are linked to rainfall and show a short term variation with the annual cycle of weather and a longer term variation with climatic change. Therefore,

the maximum stable angle of a slope will vary through time as groundwater level varies. However, it may be assumed that, ultimately, the least stable groundwater condition (excluding artesian conditions), that of ground water at the surface, will occur. If the maximum stable slope angle for this condition is calculated it will indicate a maximum safe, slope angle for that lithology, for long term stability. In the time since the last Ice Age the 'groundwater level at the surface' condition will probably have occurred and failure of slopes steeper than the maximum stable angle will have taken place, reducing the slope angle until a mature stable slope is formed. These mature slopes will now be at, or below, the maximum stable angle. Slopes that exceed this angle may not be mature slopes and

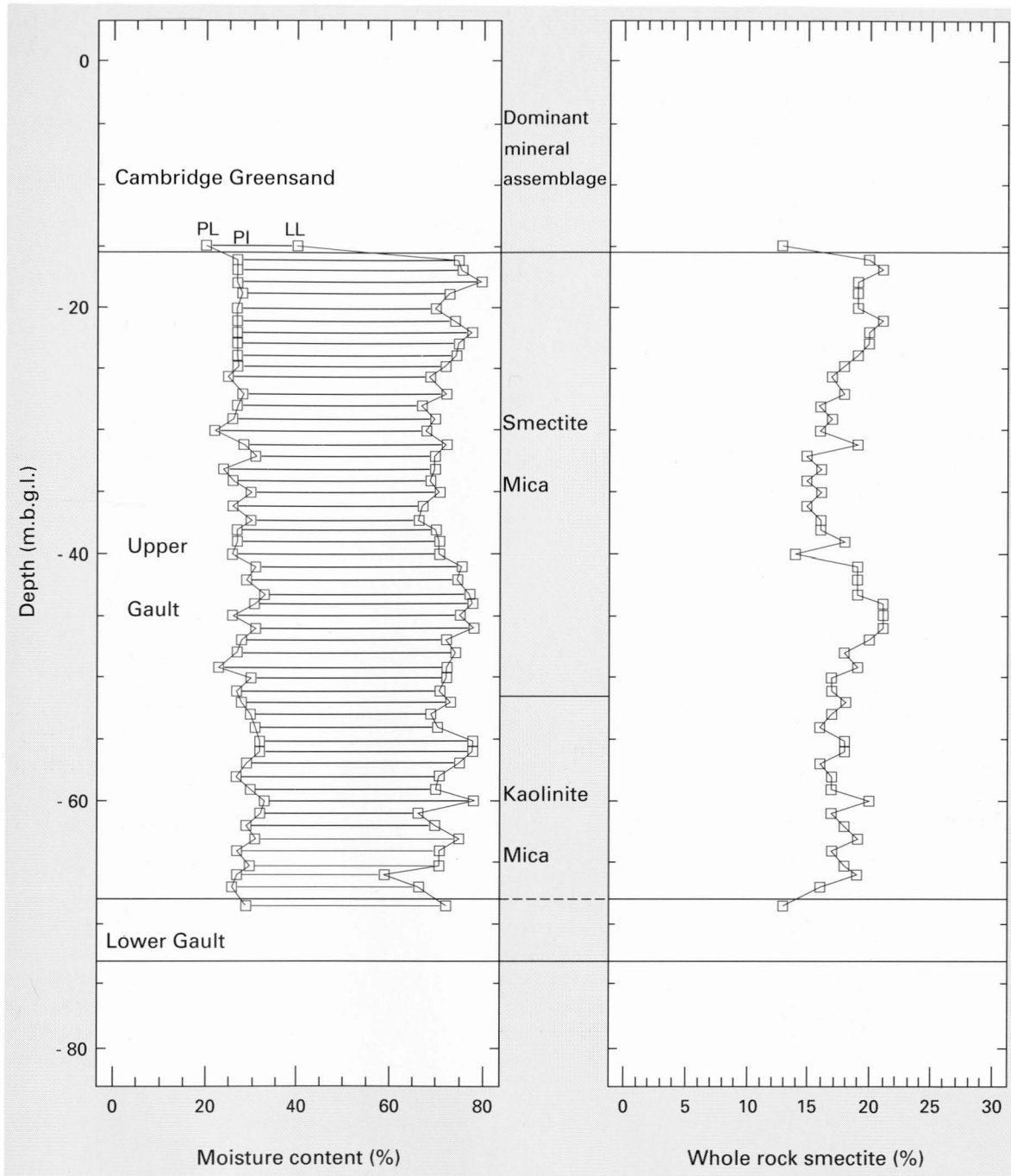

Figure 8.3 A plot of Atterberg limits with whole sample smectite content and clay mineral assemblage for samples from the Arlesey borehole.

may still be at risk from landsliding if groundwater conditions alter.

Examination of slope angles formed by landslide-prone lithologies in the field, in both slipped and stable areas can establish the maximum angle for long term stable slopes which can be compared with the theoretical value calculated using geotechnical test data and the Skempton-De Lory infinite slope equation (Forster and Culshaw, 1994).

8.1.2 Shallow slope instability

Gault clay is a high-to-extremely-high plasticity, over-consolidated clay and therefore, it is particularly prone to landsliding. Shallow landsliding in Head deposits derived from Gault clay may also present potential instability prob-

lems. Head is in a remoulded condition and, therefore, tends to have strength parameters close to the residual strength of its parent material. Its formation may have included processes such as solifluction which left ancient shear surfaces within the material. Therefore, even on modest slopes, Head deposits may suffer slope instability problems due to its inherent weakness or the reactivation of ancient shear surfaces. Unstable slopes are often capped by the Upper Greensand, gravel or sandy Head. The residual angle of internal friction of Gault clay in the Thame area was found to be in the range 17°–32° (triaxial tests) or 10°–15° (ring shear tests), these values are broadly consistent with values from other areas quoted in section 6. The calculated maximum slope angle for conditions where groundwater is at the surface is 12.5° using a residual angle of internal friction

determined by triaxial compression tests and 6° using a residual angle of internal friction determined by ring shear tests. The slope angle based on triaxial test results may be an overestimate because the test may not take into account the effect of fissuring in the soil mass which would weaken the material as a whole. However, the ring shear test, which uses completely remoulded material, may underestimate the slope angle. The average angle of stable Gault clay slopes observed in the Thame area is about 7° and the maximum angle of observed slopes is 9° . These figures are between the two laboratory based estimates. The slope angles found on landslid Gault clay slopes vary from 7° to 14° with an average of about 10° . Therefore, the limiting angle for shallow landslides in the Thame area would appear to be about 7° . This figure is probably applicable to slopes over much of the Gault outcrop.

8.1.3 Major deep-seated landslides

Major deep-seated landslides involving Gault clay are much less common than shallow slides but they can be the cause of significant damage and are much more difficult to control. Deep-seated slides occur typically at coastal outcrops where erosion by the sea maintains a high, steep, cliff profile. Examples of deep-seated slides are found on the southern coast of the Isle of Wight notably at Ventnor and at Folkstone Warren near Dover. Deep-seated movements also occur inland where there is a suitable escarpment as is the case at Shaftesbury, Dorset. The mechanism by which these deeper slides take place is different to that of shallow sliding and the influence of near, horizontal, preferred planes of weakness has been cited by some authors as being the controlling factor in the case of the Gault clay (Bromhead et al., 1991; Hutchinson et al., 1991; Gostelow, 1991), and other clay formations (Barton, 1984; Barton and Thomson, 1988; Bromhead, 1978).

The origin of these preferred planes of weakness is not well understood and has been attributed to several possible mechanisms. Hutchinson (1988) showed that under mild tectonic compression interbed displacement of up to 100 mm can occur where a thick brittle clay is adjacent to a stiffer stronger rock. The displacement would be sufficient to cause shear failure and a reduction of the peak friction angle to the residual value thus supplying a potential failure plane for landsliding. Barton and Thomson (1988) discussed the possibility of layered mineralogical composition, and thin, confined, aquifers under high piezometric pressures. Gostelow (1991) put forward a mechanism involving transient water pressures set up during the evolution of the sedimentary basin containing the Gault.

The investigation of the landsliding at Shaftesbury (Gostelow, 1991) indicated that a failure plane which had been intersected by two site investigation boreholes had followed a narrow band enriched in smectite (Bloodworth, 1990). This band was attributed to the deposition of secondary bentonite derived from an adjacent volcanic ash blanketed landmass. Detailed geotechnical and mineralogical examination of a failure plane in material from a cored borehole at Klondyke farm (TL 5940 7010) showed no major difference in matrix fabric between the area of the failure plane and other samples in the borehole. However, the precipitation of smectite along micro fractures appeared to have been responsible for the failure plane development (Prior et al., 1993). To what degree there is a potential for smectite-rich bands to act as incipient failure surfaces is not clear. However, if they do act in this way then they would not be sufficiently thick or

widespread throughout a sequence to be detected by normal geotechnical sampling and testing and other methods must be developed to detect them.

8.1.4 Implications for land use and construction

Although some active landsliding in Britain is due to natural causes the main cause of first time landsliding and the reactivation of ancient landslides has been attributed to human activity (Anon, 1990b). Common causes of slope instability are the removal of support from the foot of a slope, loading at the top of a slope, deforestation, decreased strength due to weathering or the build up of high pore water pressures within the slope. These changes may be the result of natural processes or may be brought about artificially. It is very important that any work that affects natural slopes in Gault clay avoids undercutting, top loading and, above all, the introduction of large amounts of water to the slope. When dealing with a sloping site or a site adjacent to a slope, a survey should be carried out to determine not only the stability of the slope within the site but also the stability of the area around it, especially up and down slope, which may affect, or be affected by, the development of the site. The survey may include aerial photography, engineering geomorphology mapping, trial pitting, boreholes, field testing, geophysical investigation and laboratory testing. The results of the survey should enable a calculated stability analysis to be carried out. Depending on the findings of the study, slope instability mitigation measures might be required such as regrading, vegetation, the installation of shear keys, the construction of a free-draining counterweight at the toe, the removal of water from the slope and its surrounding area (drainage) or a combination of such measures. It is important that water is removed from a susceptible slope to an area which will not, itself, be made unstable. Removal should be done in such a way that the method of removal is not liable to be disrupted by minor landslide movements resulting in the discharge of water onto the slope itself.

8.2 FOUNDATIONS

8.2.1 Shrinking and Swelling

When clay soils absorb water or become desiccated their volume increases or decreases respectively. The magnitude of the change in volume is controlled, primarily, by the type of clay minerals present and is indirectly measured by the plasticity of the clay soil (where the clay fraction forms a significant proportion of the soil). Two modes of swelling in clay minerals are recognised, inter-crystalline swelling and infra-crystalline swelling (Grim, 1962). Inter-crystalline swelling occurs when moisture is taken up on external clay crystal surfaces and in inter-crystal voids; this causes relatively small volume changes. Infra-crystalline swelling occurs when moisture is taken up between the weakly bonded inter-molecular layers of the clay crystal and gives rise to very large volume changes with variation in moisture content. This mode of swelling is characteristic of the smectite family of clay minerals. Gault clay, in some areas, contains significant amounts of smectite clays and reference to the plasticity chart Figure 6.21. shows it to be of mainly high to very high plasticity. As a general rule for clay soils, the higher the plasticity the greater is the soil's potential for volume change with changes in moisture content. The activity chart Figure 6.24 shows that Gault

clay falls in the very high expansive potential zone except for the outcrop in the south-west (area 1) which is only of medium to high expansive potential because the Gault becomes siltier and more sandy in this area.

The ground below a typical green field site on shrinkable clay may be subject to a seasonal variation in moisture content to a depth of 1 m to 1.5 m. This will cause shrinking and swelling of the clay soil and in years of severe drought this may result in damage to foundations in the soil which have been insufficiently deeply placed, and, hence, damage to the super-structure. Since the 1940s the Building Research Establishment has recommended that a minimum foundation depth of 0.9 m is needed to avoid seasonal volume changes due to wetting and drying when construction is on an open site on swelling clay, (Anon, 1993).

Where trees, shrubs or hedges are growing on a clay soil site a zone of reduced moisture content, compared to the surrounding soil, may be detected to a depth of 5 m or 6 m below the vegetation and a zone of permanent desiccation may be present below large trees. Where trees, shrubs or hedges are removed prior to construction, there will be a potential for long term swelling and surface heave as the desiccated soil re-establishes an equilibrium moisture content with its surroundings. This rise in the ground surface will not necessarily be uniform over a site and the resulting uplift could be potentially damaging to shallow, strip foundations. The use of bored piles linked by a reinforced ground beam may be preferable to a deep strip foundation taken to below the desiccated zone. In the case of floor slabs, strip, and piled foundations precautions should be taken to allow for, or avoid, lateral and upward forces. Compressible material may be placed adjacent to strip foundations and below ground beams and floor slabs to allow for seasonal stresses. The upper part of piles may be sleeved in polythene sheeting, pvc or cardboard tubes, to allow for negative skin friction, and the pile itself reinforced. Alternatively, suspended floors could be used instead of floor slabs on compressible material. The design of foundations on shrinkable clay sites is discussed in Building Research Establishment Digest 241 (Anon, 1980b).

The effect of trees in the post-construction phase can be equally damaging if planted too close to a building. The severity of the drying and shrinking of the soil caused by the removal of the soil moisture by the tree's roots will depend on the size and species of the tree. In general, trees should not be planted closer to a building than $0.5\text{--}1.0 \times$ the height of the mature tree unless suitable deep foundations have been used to minimise the effects of soil desiccation due to the tree. In the case of existing trees a number of management options are possible to restrict growth and minimise soil moisture variation (Anon, 1985).

In industrial buildings in which processes involving large amounts of heat are installed, consideration must be given, at the design stage, to the potential for the drying out of the clay below the factory floor and the consequent effects of the clay shrinkage on the floor slabs and foundations.

8.2.2 Chemical attack on buried concrete

Gault clay contains iron sulphide which may break down on weathering and under the influence of bacterial action to form sulphuric acid and sulphates in acid solution. If calcium carbonate is available, for example, from fossils, then calcium sulphate may be formed as selenite crystals.

The presence of aqueous solutions of sulphate and sulphuric acid in the ground gives a potential for chemical attack on buried concrete which may reduce the effec-

tiveness of buried structures. The sulphates and sulphuric acid react with tri-calcium aluminate in Portland cement to form calcium sulpho-aluminate or ettringite. This reaction is accompanied by expansion and loss of strength. The rate of attack is influenced by the permeability of the concrete and the position of the groundwater table (sulphates are brought into contact with the cement in concrete by movement of their solutions in water). If a structure is permanently above the water table it is unlikely to suffer attack. When a structure is below the groundwater table but the groundwater is not mobile, reaction will be limited as the sulphates in the groundwater are not replaced. However, if there is movement of the groundwater then the sulphate removed by reaction with cement will be replaced, thereby continuing the process. Structures such as retaining walls, which have only one side in contact with the groundwater, are particularly vulnerable if water drains behind or through them.

Concrete of low permeability is required to resist sulphate attack, hence it should be adequately compacted and cured. Additionally, sulphate-resistant cements, that is, those in which the tricalcium aluminate is low, can be used to reduce the potential for chemical reactivity. However, where soil permeability is low, or when groundwater flow is very low or absent, the potential for attack will be low even where the sulphate content of the soil is quite high. In some circumstances it may be acceptable, and cost effective, to allow for a few centimetres of concrete to be sacrificed on the outside of a mass concrete structure rather than use a sulphate-resistant cement or to protect the concrete from sulphate attack by using impermeable geo-membranes or bituminous or epoxy tar coatings (Lea, 1970).

Chemical tests recorded in the Gault clay database indicate soil conditions to be generally near to neutral or of slightly alkaline pH, only very rarely have low pH values indicating potentially damaging acidic conditions been recorded (Figure 6.11). Therefore, acid attack on concrete or metal services below the water table is unlikely.

The database values for sulphate content and sulphate class were derived largely from site investigations carried out before 1991. These investigations carried out sulphate testing in accordance with contemporary British Standard procedures. In the case of sulphate these were the methods described in Building Research Establishment Digest 250 (Anon, 1981a) which included acid extraction to give total sulphate. In 1991 the recommendations in Digest 250 were superseded. The more recent Digest 363 (Anon, 1991) emphasises the classification on the basis of sulphate solubility in water. As a consequence, formations containing gypsum are moved to lower classes than those indicated by tests based on acid soluble sulphate content. Consequently, some of the data quoted for gypsiferous formations such as the Gault clay may indicate higher sulphate classes than would be the case if tested by the current recommendations in Digest 363.

The database values for Gault clay (Figure 6.8) indicate that total sulphate content ranges from 0.02% to 3.5% with a median value of about 1.1%. In terms of the old standard this would indicate sulphate classes of 1 to 5 with a median value of 2. However under the new recommendations the sulphate class would need to be reassessed for all samples with a sulphate content greater than 0.24%, using a 2:1 soil water extract. The soil water extract would be expected to reduce the sulphate class of the sample from the original classification. However, the presence of high sulphate values in some samples of Gault clay indicate that there is a potential for attack which would require sulphate-resistant concrete mixes or other preventive measures to be used.

The problem of sulphate attack is also a potential problem with the use of lime stabilisation of clay for road sub-base. In the alkaline conditions caused by the addition of quicklime, clay minerals will react chemically and release alumina. The alumina will combine with sulphates to produce calcium aluminium-sulphate hydrate compounds and finally ettringite or thaumasite which will hydrate in the presence of water with a significant increase in volume, hence causing breaking of the road.

8.3 EARTHWORKS

8.3.1 Excavations

As a heavy clay, Gault clay may be expected to be classed as medium to hard with respect to its diggability and it should be workable using normal digging machinery. The choice of machinery will depend on the site itself and will

be governed by the volume and distance that material has to be moved. However, Gault clay is a fissured, over consolidated clay and the stability of the sides of the excavation itself may present problems of instability during and after excavation.

Fissuring in the clay may have been caused by one or a number of processes which have acted on the clay during its geological history. Fissuring may have resulted from tectonic movement, stress relief on the removal of overburden, desiccation, glacial loading, solifluction or landsliding. The fissures which result from these phenomena may reduce the strength of the material to only slightly higher than its residual value (Skempton et al., 1969). Thus, even on flat ground, fissures may be present which are inclined into the excavation at angles greater than the residual friction angle and, where intersected by the excavated face, may act as failure planes for slides into the excavation (Plate 4). Since the effective residual friction

Plate 4 Cutting in Gault clay on the route of the M40 Motorway where a slide has occurred on a discontinuity in the clay which is dipping out of the cut face at a high angle. The face is capped by a thin layer of gravelly sand.



angle ranges recorded in the database range from about 10° to 30° there is a significant potential for side collapse into the excavation along fissures inclined at steeper angles than these figures.

In addition to the problems posed by fissures, the fabric of the Gault clay is usually affected by weathering to a depth of several metres. In those areas which were subjected to periglacial action during the last Ice Age cryoturbation may have disturbed the structure of the clay and may have brought about the introduction of overlying deposits of contrasting geotechnical properties into the clay. Features such as sand-filled ice wedges may be encountered in excavations which will themselves be unstable at the angle of cut and, if water-bearing, may cause the clay to soften to the detriment of its stability.

The inflow of water into an excavation in Gault clay may take place through normal precipitation as rain or snow, through overlying permeable strata or from surface water courses. The result may be to cause problems to construction due to the increased moisture content of the clay making traffic movement on site difficult or impossible for wheeled vehicles especially on temporary haul roads (Plate 5). Where water is allowed ingress to foundation excavations, the wetting of the clay may cause soft patches in the sub-foundation clay which may require removal before foundation placement. If this is likely to be a problem then a blinding of lean concrete immediately after excavation may be necessary to protect it from wetting.

8.3.2 Cuttings and embankments

The assessment and measurement of pore water pressure distribution is necessary for the calculation of effective stress in slope stability analysis for cuttings and embankments. Seepage forces also have a bearing on stability if seepage velocities are sufficiently high, and a study of total head distribution is necessary to assess its effect. If seepage has a major component normal to, and into, the slope it would tend to have a stabilising effect (Crabb and West, 1986).

Landslides in the Gault are often initiated after high or intense rainfall. Crabb and West (1986) monitored an embankment, 7 m high, with slopes of 1:2 built of over-consolidated, part re-moulded, Gault clay on the Cambridge Northern Bypass (A45). They found that cyclic annual changes in pore water pressure occurred to a depth of about 2 m, with the highest pore water pressures occurring at the end of the winter. This coincided with the period when most landslides occurred. The slope was wettest at the toe, but there was also an area of positive pore water pressure higher up in the slope at the end of the winter, demonstrating that infiltration can occur further up slope, perhaps through soil cracks. Since macro permeability appears to greatly exceed micro permeability in the Gault, it is possible for an out-of-phase pore water pressure condition to exist, which would have a significant effect on short-term failure (Chinsman, 1972).

The long term stability of motorway cuttings and embankments in England and Wales has been reported by Perry (1989). The study concentrated on selected lengths of motorway which included the principal geological formations encountered by the motorway system, including the Gault. Gault clay proved to be the geological material with the highest percentage failure rate for both cuttings and embankments. The failure rate for cuttings was 9.6% and for embankments 8.2%. The slopes had been cut mainly at a slope of 1:2.5 (22°) but sometimes 1:3 (18°) and were 10 or 22 years old. In both embankments and cuttings the susceptibility to failure increased with increasing slope height and increasing age. Twenty two year old, Gault clay cuttings with slopes cut at 1:3 between 5.0 m and 7.5 m high had a failure rate of more than 50%. Slopes associated with open ditches were more likely to fail than slopes without drains. The maximum slope angles recommended by Perry (1989) for cuttings and embankments in Gault clay in order to restrict the failures to less than 1% within 22 years of construction are:

Slope height	Slope height	Slope height
0 m–2.5 m	2.5 m–5.0 m	>5.0 m
1:3.5	1:4	1:5

Plate 5 Arlesey Brickpit. Remoulded, wet Gault clay in the pit floor causing poor trafficability.



8.4 SITE INVESTIGATION PROCEDURES

The design of a site investigation should include a desk study and walk-over survey as described in Building Research Establishment Digests 318 and 348 (Anon, 1987b, 1989). Where the investigation is in an area which includes sloping ground, even slopes as low as 7°, it is important to look at slopes outside the prospective development in order to ascertain the stability of slopes which could affect the developed area should they fail. Air photography, engineering geomorphology and geophysics may be used to advantage where conditions are suitable and expert advice should be taken as to their application to the site in question.

The use of cable percussion drilling methods in the Gault clay may be effective for recovering disturbed samples, such as required for testing for earthworks. However, sampling by means of U 100 driven samples may not prove effective for obtaining undisturbed samples. The use of driven sampling tubes in deep boreholes may reduce the sampled material to shattered lumps of clay due to the opening up of fissures (Woods, 1955) thus reducing the ability to determine structural and textural information. The use of modern, rotary coring methods with water or mud flush can produce very good quality samples. Although, in the past, rotary methods have encountered problems such as difficulty in extracting the core barrel from the borehole, the need to ream out the borehole before the next core run and core softened by absorbing water from the flushing medium (Samuels, 1975).

In the shallow, near-surface zone, where the weathering state and periglacial disturbance is of major importance the use of trial pits has significant advantages over the use of cable percussion or rotary drilling. This is especially true where slope stability is being assessed and the logging of shear surfaces and discontinuities is important. In order to

obtain the maximum information from a pit it is desirable for the pit to be viewed and logged by an engineering geologist during its excavation in order to identify shear surfaces which may be obscured in the finished pit walls by smearing. These surfaces are frequently revealed as planes of detachment as the excavator bucket removes material from the pit. If safe to do so, the dip and strike of the plane may be measured and a block sample taken for shear strength measurement in the laboratory. The detection of thin shear planes in the pit walls is difficult after excavation, even when the face has been cleaned by a sharp tool. When working in any excavation it is essential that safety procedures are observed and suitable support is installed to maintain the safe standing of the pit walls during logging and sampling. When working with weak, sheared, disturbed material, such as soliflucted and cryoturbated Gault clay, the importance of safe working practices cannot be over emphasised.

The use of geophysical methods in conjunction with more established investigation procedures may be helpful in the early stages of site investigation especially in areas of slope instability. Geophysical techniques can be used to help determine the dimensions of landslide masses, the depth to failure planes, the distribution of areas of high moisture content, the location of perched water tables and the depth to the regional water table. Methods which have been used with success on landslides include resistivity, conductivity and seismic refraction but better equipment and new methods are constantly being developed and other techniques may also offer useful information. It is important that geophysical methods should be seen as part of an integrated site investigation programme and that a limited trial be made to establish the most suitable technique before a full scale geophysical survey of the whole site is commissioned. McCann and Forster (1990) reviewed the use of geophysical methods in landslide investigations.

9 Conclusions

GEOLOGY

The Gault is a sequence of predominantly clay facies sediments with mudstones, thin siltstones and bands of phosphatic nodules of Middle and Upper Albian age (Lower Cretaceous). In East Anglia and East Kent, the clay facies extends upwards to include sediments of Upper Albian age. In the northern part of East Anglia the clays are replaced by the Red Chalk, a carbonate facies equivalent to the Middle and Upper Albian elsewhere, which reaches a maximum thickness of approximately 2 m. The clay thickens to the south and reaches its maximum development of over 100 m in the Weald. It then thins to the west as it passes into Hampshire and Dorset, the upper zones being replaced by sand and chert of the Upper Greensand. The Gault can be divided into two parts on the basis of lithology, the Lower and the Upper. The Lower consists mainly of medium and dark grey, weak mudstones and silty mudstones. The Upper division is paler, has a higher calcium carbonate content, and smectite is the dominant clay mineral group.

MINERALOGY

Gault clay contains both clay and non-clay minerals. The major non-clay minerals are quartz and calcite. Quartz usually makes up about 20% or more of the Gault and its distribution is fairly uniform. Calcite is present mainly as shell fragments and micro fossils (coccoliths); recrystallised calcite may act as a cementing agent. The Upper Gault clay tends to be more calcareous than the Lower Gault clay and in the north east the formation tends to be more calcareous than to the south and west. In the near-surface zone calcite may be converted to gypsum by its reaction with acid groundwater produced by the oxidation of pyrite. Other non-clay minerals present are feldspar, mica and pyrite. Two authigenic minerals, clinoptilolite and opal-CT, are found in the upper part of the Upper Gault clay at Harwell and may act as cementing agents.

The major clay minerals present are kaolinite, illite and smectite. Two main clay mineral assemblages have been identified:

- 1) 'Kaolinite-illite'. This is characterised by kaolinite and illite with variable amounts of smectite, vermiculite and various mixed layer clays.
- 2) 'Smectite-illite'. This is characterised by smectite and illite or mixed layer smectite/illite; kaolinite is present as a minor or trace component. Within this assemblage two sub-assemblages are recognized:
 - i) smectite-illite and ii) smectite-illite-quartz-opal-CT-zeolite.

The distribution of the clay assemblages within the Gault clay has been defined by Jeans (1978) and Jeans et al. (1982). Secondary bentonite is found as localised deposits at the base of the Gault and has been found in a number of boreholes, (Leighton Buzzard, Waringham and Folkestone). Above these deposits the kaolinite-mica

(illite) assemblage is present throughout the Gault in the north-east (Cambridgeshire and Norfolk). To the south and west the top of the kaolinite-illite assemblage is found successively lower in the sequence further south and west until the boundary is at about the Lower/Upper Gault interface in the Kingston Lisle, Glyndebourne and Shaftesbury areas. Above the kaolinite-illite assemblage the smectite-illite assemblage is present. This is usually the smectite-illite sub-assemblage of bentonitic clay origin but in the upper part of the Upper Gault in the Harwell borehole the smectite-mica-quartz-opal-CT-zeolite sub-assemblage is present, which is more typical of the Upper Greensand. It is suggested that the influx of smectite in the Upper Gault was due to volcanic ash eroded from a nearby landmass (Jeans, 1982).

Higher concentrations of smectite have been found in fissures and in the zones around shear surfaces in landslides, this may be due to shearing following weak zones of high smectite content material deposited as ash falls or to smectite formation in already fissured, tectonically faulted or slipped material. Diagenesis may have produced the high smectite content in the upper part of the Gault clay at Harwell.

GEOTECHNICAL DATABASE

A geotechnical database for Gault clay was compiled using site investigation reports selected from the data collected during the project and entered into a computer. The majority of the data were taken from a relatively small number of investigations for major road developments. Such investigations provide good quality data, often across the entire outcrop, or for a considerable distance along it. These were supplemented by the reports of investigations for smaller local developments.

The data were divided into eight geographical areas to study regional variation in geotechnical properties. The division was based on data distribution, rather than geological criteria, to ensure sufficient data in each area for statistical analysis. Areas 1 to 3 cover the main outcrop from Wessex to Cambridgeshire. Areas 4 and 8 cover the western and southern outcrops of the Wealden syncline respectively. Given the abundance of available motorway data, the central section of the northern outcrop was divided into three areas, 5 to 7.

The data subsets were analysed and the results displayed as box plots which give a simple, compact, graphical method of summarising a frequency distribution, based on the robust median and quartiles. The summaries of the geotechnical data are useful guides to the engineering properties of the Gault provided the limitations in the quantity and quality of the source data are remembered and over-interpretation is avoided.

GEOTECHNICAL PROPERTIES

Whilst Gault clay in the United Kingdom may be described generally as a moderately to extremely plastic, over-

consolidated, very stiff to hard, clay soil or a weak mud-rock, study of its geotechnical properties has shown that important regional variations in its geotechnical properties exist, and consequently its engineering behaviour varies regionally. These appear to be largely a function of lithology which in turn is a function of depositional environment and stress history.

Taken as individual borehole records, the geotechnical index parameters generally show little variation with depth where the Gault is at outcrop, except near to the surface. However, where the full deposit of Gault has been tested at subcrop and at considerable depth, as at Harwell, the Channel Tunnel, and the Ely–Ouse Tunnel, index properties show greater variation, including minor cyclicality, with depth which probably relates to minor lithological variations, in particular those related to particle size.

The Atterberg limits appear to bear a relationship to the calcium carbonate content, though not a simple one. The Gault is generally a silty clay, often with similar proportions of silt and clay size fractions. Despite this, it may be highly plastic and even extremely plastic, due to the relatively high content of smectite within the clay size fraction. Comparison of clay mineral contents from geochemical analyses and clay size fractions from mechanical analyses suggest that some determinations of clay size fraction may be inaccurate due to the difficulty of achieving complete disaggregation. A significant layer of extremely high plasticity Gault clay with liquid limits as high as 180% has been identified at Harwell within the depth range 94 m to 119 m. The plasticity of samples from elsewhere was found to be less than 125%.

The relationship between carbonate content and clay size content, and between carbonate content and index geotechnical parameters has been found to be different at different locations. Gault clay has a very variable carbonate content and in some cases it may be classified as a marl.

Values of effective residual shear strength, required for landslide analysis, have been found to be reasonably consistent for a given test type and a given normal applied stress. Values are low for high plasticity Gault clay. Gault clay is particularly susceptible to swelling and shrinkage, to the extent that the engineering environment may be badly affected. Swelling data are sparse in the database and when present, they are often unclear and do not correlate well with geotechnical index tests. In part, this is due to the diversity of test types and correlations which may have been derived from other soil types. However, most indications are that the Gault clay has a high swelling potential and has shown high swelling pressures and swelling strains under certain conditions. The ‘free-swell’ test is simple and may be a useful index test to use with the Gault clay. Consolidation data have revealed an apparent wide variation in pre-consolidation stresses, as derived from oedometer or triaxial tests. However, reliable data are limited and an areal interpretation is difficult to make with any confidence.

The correlation of geotechnical properties between boreholes or between areas of the U.K. has proved to be difficult because poor stratigraphic descriptions of the formations in site investigation boreholes hinders their direct comparison.

GROUNDWATER CONSIDERATIONS

Gault clay, has a significant influence on regional groundwater systems, affecting the recharge, discharge and

hydrochemistry of the surrounding aquifers. The near-surface hydrogeology of Gault clay is strongly linked to its level of disturbance and weathering. Locally measured hydraulic properties of the Gault may not give a representative picture of its regional values because flow through the matrix is extremely slow and heterogeneity, particularly fracturing, is a significant control on groundwater flow. Also, it is important to measure in-situ hydraulic conductivity to assess bulk permeability, and to define the significance of groundwater chemistry which is dependent on the method of abstraction of the sample. Profiles of natural groundwater chemistry can be useful in helping to evaluate groundwater flows through mudrocks.

For a waste disposal site or a clay liner to such a site, the clay mineralogy of the Gault clay may play an important role in the retardation of the passage of contaminants, and, in the former case, the Gault’s calcite content would be an important buffer to acidic leachates.

The Gault is an important modifier of the regional hydrogeological regime. It restricts groundwater fluxes through it and therefore helps to control the recharge and discharge of adjacent aquifers. The Gault acts as an imperfect confining layer over underlying aquifers and the Upper Greensand may locally act as a combined aquifer system with the overlying Chalk.

IMPLICATIONS FOR LAND USE

The problems posed by the Gault clay are largely a result of its geological history and mineral composition, namely discontinuities and the presence of smectite clays. High smectite content may increase plasticity, decrease strength, cause large volume changes with moisture content variation, high swelling pressures, low angles of internal resistance and low residual strength.

Landslides

Ancient and recent landslides have been recognised, and in some areas mapped, throughout the outcrop of the Gault. The review of research into landsliding in Great Britain commissioned by the Department of the Environment (Anon, 1987a) attributed a landslide density of 5.00 to 9.99 landslides per 100 km² to the Gault outcrop. However, the study was based on information from published sources and could not take into account the very large number of landslides which were unrecorded or unrecognised.

Most movement is of shallow translational type with rotational elements at the back scarp and flows at the toe region. Multiple retrogressive rotational failures occur on some slopes. Movement may be difficult to classify in detail since the characteristic topographic features, which enable the type of movement to be identified, have often degraded to an indistinct hummocky topography of coalesced slumps and flows with varying degrees of weathering. In some areas where Gault clay is part of a major, inland escarpment or coastal cliff large, deep seated, landslide complexes have developed.

Examination of the geological setting of the shallow landslides in Gault clay show that they are frequently overlain by more permeable strata (Upper Greensand, superficial deposits) which, if they are water bearing, will cause a spring line to form at the interface with the relatively impermeable strata below. Water issuing from the springs increases the pore water pressure in the material reducing its strength and, therefore, the stability of the slope.

Examination of slope angles formed by landslide-prone lithologies in the field, in both slipped and stable areas can establish the maximum angle for long term stable slopes which can be compared with the theoretical value calculated using geotechnical test data and the Skempton/De Lory infinite slope equation.

Deep-seated major landslides involving Gault clay are much less common than shallow slides but they can be the cause of significant damage and are much more difficult to control. Deep-seated slides occur typically at coastal outcrops where erosion by the sea maintains a high, steep cliff profile. The mechanism by which these deeper slides take place is different to that of shallow sliding and the influence of near-horizontal, preferred planes of weakness has been cited by some authors as being the controlling factor in the case of Gault clay (Bromhead et al., 1991; Hutchinson et al., 1991; Gostelow, 1991), and other clay formations (Barton, 1984; Barton and Thomson, 1988; Bromhead, 1978).

Although some landsliding in Britain is due to natural processes the main cause of recent, first time landsliding and the reactivation of ancient slides has been attributed to human activity (Anon, 1990b). Common causes of slope instability are the removal of support from the foot of a slope, loading at the top of a slope, deforestation, decreased strength due to weathering or the build up of high pore water pressures within the slope. Where the stability of a site is in doubt, a survey should be carried out to determine its stability and the stability of the surrounding area which may affect, or be affected by, development of the site. Depending on the findings of the study slope instability mitigation measures might include regrading, vegetation, the installation of shear keys, the construction of a free draining counterweight at the toe and the removal of water from the slope and its surrounding area.

Shrinkable clay

When clays absorb or release water their volume increases or decreases respectively. The ability to undergo large volume changes is controlled, primarily, by the type of clay minerals present and is characteristic of the smectite family of clay minerals. Gault clay contains significant amounts of smectite clays in parts of its sequence. Although in the south-west, where the Gault becomes siltier and more sandy, it is only of medium to high expansive potential the remainder of the outcrop falls almost entirely in the very high expansive potential category.

Shrinkable clay may be subject to seasonal variation in moisture content to a depth of 1 m to 1.5 m. If foundations are placed at too shallow depth on such a site seasonal moisture variations will cause shrinking and swelling which may result in damage to the foundation. The Building Research Establishment has recommended that a minimum foundation depth of 0.9 m is needed to avoid seasonal volume changes due to wetting and drying when construction is on a swelling clay, open site (Anon, 1993).

Where trees shrubs or hedges are present the zone of moisture reduction may extend to a depth of 5 m or 6 m. When such vegetation is removed prior to construction, there will be a potential for long term swelling and surface heave as the desiccated soil re-establishes equilibrium moisture content with its surroundings. This rise in the ground surface will not necessarily be uniform over a site

and the resulting uplift could be potentially damaging to shallow, strip foundations. The use of bored piles linked by a reinforced ground beam may be preferable to a deep strip foundation taken to below the desiccated zone. In the case of floor slabs, strip and piled foundations precautions should be taken to design for, or avoid, lateral and upward forces (Anon, 1980b).

The effect of trees in the post construction phase can be equally damaging if planted too close to a building. In general trees should not be planted closer to a building than $0.5-1.0 \times$ the height of the mature tree.

Chemical attack

The Gault clay contains iron sulphide which may weather in the near-surface zone to form sulphuric acid which can react with calcite to form gypsum. The presence of aqueous solutions of sulphate and sulphuric acid in the ground gives a potential for chemical attack on concrete. The rate of attack is influenced by the permeability of the concrete and the position of the groundwater table. Concrete above the water table will be unaffected and concrete of low permeability will resist sulphate attack. Also, sulphate-resistant cements can be used to reduce the potential for chemical reactivity or concrete can be protected from sulphate attack by the use of a wide range of materials including impermeable geo-membranes and impermeable coatings. Alternatively allowance may be made in the foundation design for sacrificial cover.

Excavation

As a heavy clay Gault clay may be expected to be classed as medium to hard with respect to its diggability and it may be moved using normal digging machinery. However, Gault clay is a fissured overconsolidated clay and the stability of the sides of the excavation itself may be a problem during and after excavation. The fissures may reduce the strength of the material to only slightly higher than its residual strength. (Skempton et al., 1969). Thus, fissures which are inclined into the excavation at angles greater than the residual friction angle and are intersected by the excavated face will be likely to act as failure planes for a slide into the excavation.

The Gault clay is usually affected by weathering to a depth of several metres and in those areas which were subjected to periglacial action during the last Ice Age cryoturbation may have introduced overlying deposits of contrasting geotechnical properties into the clay. Features such as sand wedges may be encountered in excavations which will themselves be unstable at the angle of cut and may be water-bearing causing the clay to soften to the detriment of its stability.

The inflow of water into an excavation in Gault clay may wet the clay making movement difficult or impossible for wheeled vehicles and may cause soft patches in sub-foundation clay which may require removal before foundation placement.

Cuttings and embankments

The long term stability of motorway cuttings and embankments in England and Wales was studied by Perry (1989). The Gault proved to be the geological formation with the highest percentage failure rate for both cuttings and embankments. The recommended maximum slope angles for cuttings and embankments in order to restrict

the failures to less than 1% within 22 years of construction are:

Slope height	Slope height	Slope height
0 m–2.5 m	2.5 m–5.0 m	>5.0 m
1:3.5	1:4	1:5

Site investigation

The design of a site investigation should include an initial a desk study and walk-over survey. Where the investigation is in a sloping area it is important to consider slopes outside the prospective development to ascertain their potential for instability which could impinge on, or be caused by, the development.

The use of cable percussion drilling methods and sampling by means of U 100 driven samples may suffer some limitations when used in the Gault clay. The use of

modern rotary coring techniques offer, higher quality samples but in the past has encountered problems in extracting the core barrel from the borehole and the need to ream out the borehole before the next core run. Precautions may be needed to avoid the core absorbing water from the flushing medium and softening.

In shallower, near-surface zones, where the weathering state and periglacial disturbance is of major importance, the use of trial pits has significant advantages over the use of percussion or rotary drilling. When working in weak, sheared, disturbed material, such as soliflucted and cryoturbated Gault clay, it is essential that safety procedures are observed and suitable support is installed to maintain the safe standing of the pit walls during logging and sampling.

The use of geophysical methods in conjunction with more established investigation procedures may be helpful in the early stages of site investigation especially in areas of slope instability.

REFERENCES AND BIBLIOGRAPHY

- AARONS, A, WEEKS, A G, and PARKES, R D. 1977. Site investigation for the Channel Tunnel British Ferry Terminal. *Ground Engineering*, May, 43–47.
- ALEXANDER, J. 1983a. The groundwater regime of the Harwell region. *Report of the Fluid Processes Research Group Institute of Geological Sciences*, FLUPU 83-10.
- ALEXANDER, J. 1983b. The local groundwater regime of the Harwell research site. *Report of the Fluid Processes Research Group Institute of Geological Sciences*, FLUPU 83-1.
- ALEXANDER, J, and BRIGHTMAN, M A. 1985. A hypothesis to account for the groundwater quality variations in the Corallian of the Thames Valley. *Hydrogeology in the service of man: Memoirs of the International Association of Hydrogeologists*.
- ALEXANDER, J, BRIGHTMAN, M A, and MILODOWSKI, A E. 1987. Mudrock hydrogeology and hydrogeochemistry of a shallow sedimentary environment: the Middle Thames Valley area. *Report of the Fluid Processes Research Group Institute of Geological Sciences*, FLUPU 87-3.
- ANON. 1974. IGS Boreholes 1973. *Report of the Institute of Geological Sciences*, No. 74/7. 23pp.
- ANON. 1980b. Low rise buildings on shrinkable clay soils: Part 2. *Building Research Digest*, No. 241.
- ANON. 1981a. Concrete in sulphate-bearing soils and ground waters. *Building Research Digest*, No. 250.
- ANON. 1981b. BS5930: *Code of practice for site investigation*. (London: British Standards Institute.)
- ANON. 1985. The influence of trees on house foundations in clay soils. *Building Research Digest*, No. 298.
- ANON. 1987a. Review of research into landsliding in Great Britain. Geomorphological Services Ltd, Reports to the Department of the Environment.
- ANON. 1987b. Site investigation for low rise building: desk study. *Building Research Digest*, No. 318.
- ANON. 1989. Site investigation for low rise building: the walk over survey. *Building Research Digest*, No. 348.
- ANON. 1990a. BS1377: *British Standard Methods of test for soils for civil engineering purposes*. (London: British Standards Institute.)
- ANON. 1990b. Planning policy guidance 14: Development of unstable ground. Department of the Environment, Welsh Office, HMSO.
- ANON. 1991. Sulphate and acid resistance of concrete in the ground. *Building Research Digest*, No. 363.
- ANON. 1993. Low rise buildings on shrinkable clay soils: Part 1. *Building Research Digest*, No. 240.
- BAKER, M C W. 1990. Use of topographic linearments to extend the known structure and facies patterns in the Mesozoic of Southern England. *Marine and Petroleum Geology*, Vol. 7, 181–187.
- BARTON, M E. 1984. The preferred path of landslide shear surfaces in overconsolidated clays and soft rocks. *Proceedings of the 4th International Symposium on Landslides, Toronto, Canada*, Vol. 3, 75–79.
- BARTON, M E. 1987. The sunken lanes of southern England: engineering geological considerations. *Engineering Geology Special Publication of the Geological Society of London*, No. 4: Planning and Engineering Geology, 411–417.
- BARTON, M E. 1989. Landsliding in the Upper Greensand scarp slope in east Hampshire. Field Notes of Easter Meeting Engineering Group, Geological Society.
- BARTON, M E, and THOMSON, R I. 1988. Seepage characteristics and landsliding of the A3 zone of the Barton Beds. *Engineering Geology Special Publication of the Geological Society of London*, No. 3 'Groundwater in Engineering Geology', 107–114.
- BLOODWORTH, A J. 1990. Mineralogy and petrology of borehole samples taken from landslipped Gault clay, Shaftesbury, Dorset. *British Geological Survey Technical Report*, WG/90/36.
- BRIGHTMAN, M A, ALEXANDER, J, and GOSTELOW, T P. 1987. Groundwater movement in mudrocks — measurement and interpretation. *Report of the Fluid Processes Research Group Institute of Geological Sciences*, FLUPU 87-1.
- BRIGHTMAN, M A, BATH, A H, CAVE, M R, and DARLING, W G. 1985. Pore fluids from the argillaceous rocks of the Harwell region. *Report of the Fluid Processes Research Group Institute of Geological Sciences*, FLUPU 85-6.
- BRISTOW, H W. 1889. Geology of the Isle of Wight. *Memoirs of the Geological Survey of England and Wales*.
- BROMHEAD. 1978. Large landslides in London Clay at Herne Bay, Kent. *Quarterly Journal of Engineering Geology*, Vol. 11, 292–304.
- BROMHEAD, E N, CHANDLER, M P, and HUTCHINSON, J N. 1991. The recent history and geotechnics at Gore Cliff, Isle of Wight. *Slope stability engineering*, 189–196. (London: Thomas Telford for Institution of Civil Engineers.)
- BROWN, S F, AERIAL, M P, and LOACH, S C. 1990. The relationship between California bearing ratio and elastic stiffness for compacted clays. *Ground Engineering*, October, 27–31.
- BRUNSDEN, D, and JONES, D K C. 1976. The evolution of landslide slopes in Dorset. *Philosophical Transactions of the Royal Society, London*, A 283, 605–631.
- CASEY, R. 1961. The stratigraphical palaeontology of the Lower Greensand. *Palaeontology*, Vol. 3, 487–621
- CHANDLER, M P. 1984. The coastal landslides forming the undercliff of the Isle of Wight. PhD thesis University of London.
- CHANDLER, M P, and HUTCHINSON, J N. 1984. Assessment of relative slide hazard within a large pre-existing coastal landslide at Ventnor, Isle of Wight. *4th International Symposium on Landslides, Toronto, Canada*, Vol. 2, 517–522.
- CHATWIN, C P. 1938. The geology of the Selbourne district. *Transactions of South Eastern Union of Scientific Societies. Naturalist and Antiquary*, Vol. 43, 47–57.
- CHATWIN, C P. 1961. British regional geology: East Anglia. (London: HMSO for British Geological Survey.)
- CHINSMAN, B W E. 1972. Field and laboratory studies of "short term" earthworks failures involving the Gault clay in West Kent. PhD thesis. University of Surrey.
- CLARKE, B G, and ROTH, C P. 1984. Analysis of the Dunton Green retaining wall based on results of pressure meter tests. *Geotechnique*, Vol. 34, No. 4, 549–561.
- COOPER, M R, and GRANT, D I. 1989. Instrumentation systems for an experimental cut slope at Selbourne, Hampshire: design and initial performance (1984–1989). Unpublished.
- CRABB, G I, and WEST, G. 1986. Monitoring groundwater conditions in a highway embankment. *Engineering Geology Special Publication of the Geological Society of London*, No. 3: Groundwater in Engineering Geology, 387–394.
- CRABB, G I, WEST, G, and AERIAL, M P. 1987. Groundwater conditions in 3 highway embankments. *Proceedings of the European Conference on Soil mechanics and Foundation Engineering, Dublin*, Vol. 9, 401–406.

- CRIPPS, J C, and TAYLOR, R K. 1981. The engineering properties of mudrocks. *Quarterly Journal of Engineering Geology*, 14, 325–346.
- DALTON, J C P, and HAWKINS, M A. 1982. Fields of stress — some measurements of the in-situ stress in a meadow in the Cambridgeshire countryside. *Ground Engineering*, May, 15–22.
- DENIS, J H, KEALL, M J, HALL, P L, and MEETEN, G H. 1991. Influence of potassium concentration on the swelling and compaction of mixed (Na, K) ion exchanged montmorillonite. *Clay Minerals*, Vol. 26, 255–268.
- DENNESS, B. 1969. Fissures and related studies in selected Cretaceous rocks of S.E. England. PhD thesis. London University.
- DESTOMBES, J P, and SHEPHARD-THORN, R. 1971. Resultats geologiques des recherches pour l'implantation d'un tunnel sous la Manche. *Memoires du BRGM*, 79, *Colloque sur la geologie de la Manche*, 14–15 January, Paris.
- DIXON, J E, FITTON, J G, and FROST, R T C. 1981. The tectonic significance of post-carboniferous igneous activity in the North Sea Basin. *Petroleum Geology off the Continental Shelf of North West Europe* (ILLING, L V, and HOSON, G D, editors). (London: Institute of Petroleum), 121–137.
- DRUMMOND, P V O. 1970. The Mid-Dorset Swell. Evidence of Albian-Cenomanian Movements in Wessex. *Proceedings of the Geologists Association*, Vol. 81, 679–715.
- ENTWISLE, D C. 1992. Atterberg limits, particle size, and residual shear strength of borehole samples from two boreholes near Shaftesbury, Dorset. BGS (EGGG) Laboratory Report No. 92/36.
- ENTWISLE, D C. 1993. Residual shear strength of six samples from two boreholes, Arlesey, Bedfordshire and Klondyke Farm, Cambridgeshire. BGS (EGGG) Laboratory Report No. 93/2.
- ENTWISLE, D C. 1994. The mineralogy of the Gault clay. *British Geological Survey Technical Report*, WN/94/8.
- ERBA, E, CASTRODORI, D, GUASTI, G, and RIPEPE, M. 1992. Calcareous nannofossils and Milankovitch cycles: the example of the Albian Gault Clay Formation (southern England). *Palaeogeography, Palaeoclimatology, Palaeoecology*, Vol. 93, 47–69.
- FENWICK, S M M. 1994. The Hydrogeology of the Gault clay. *British Geological Survey Technical Report*, WN/94/6.
- FOOKES, P G, and DENNESS, B. 1969. Observational studies on fissure patterns in Cretaceous sediments of southeast England. *Geotechnique*, Vol. 19, No. 4, 453–477.
- FORSTER, A. 1991. The engineering geology of the area around Thame, Oxfordshire, 1:50 000 geological sheet 237. *British Geological Survey Technical Report*, WN/91/14.
- FORSTER, A. 1992. The geotechnical properties of the Gault clay near Thame Oxfordshire and their implications for engineering. *British Geological Survey Technical Report*, WN/92/13.
- FORSTER, A, and CULSHAW, M G C. 1994. Slope instability assessment from geotechnical and slope data for planning purposes. *Proceedings of the 7th Congress of the International Association of Engineering Geology, Lisbon, 1771–1775*.
- FREEMAN, I L. 1964. Mineralogy of ten British brick clays. *Clay Minerals Bulletin*, Vol. 5, 474–486.
- FUGEMAN, I C D, HAWLEY, J, and MYERS, A G. 1993. Major underground structures. *The Channel Tunnel. Proceedings of the Institution of Civil Engineers*, part 1, 87–102.
- GALE, A S. 1989. Field meeting at Folkstone Warren, on 29th November 1987. *Proceedings of the Geologists Association*, Vol. 100, No. 1, 73–82.
- GALLOIS, R W. 1965. *Regional guide to the geology of the Wealden district*. (London: HMSO for British Geological Survey.)
- GALLOIS, R W. 1988. Geology of the country around Ely. *Memoir of the British Geological Survey*, Sheet 173. (London: HMSO.)
- GALLOIS, R W, and MORTER, A A. 1982. The stratigraphy of the Gault of East Anglia. *Proceedings of the Geologists Association*, Vol. 93, No. 4, 351–368.
- GALLOIS, R W, and WORSAM, B C. 1983. Stratigraphy of the Harwell Boreholes. *Report of the Fluid Processes Research Group Institute of Geological Sciences*, FLUPU 83-14.
- GARRETT, C, and WALE, J H. 1985. Performance of embankments and cuttings in Gault clay in Kent. *Failures in Earthworks*. (London: Thomas Telford Ltd.)
- GARRETT, C, and BARNES, S J. 1984. The design and performance of the Dunton Green retaining wall. *Geotechnique*, Vol. 34, No. 4, 533–548.
- GILBERT, G K. 1895. Sedimentary measurement of Cretaceous time. *Journal of Geology*, 121–127.
- GOSTELOW, T P. 1990. Channel Tunnel: report on the Castle Hill Landslip. *British Geological Survey Technical Report*, WN/90/14C.
- GOSTELOW, T P. 1991. Geological processes and their effect on the engineering behaviour of the Gault clay and Upper Greensand; an example from Shaftesbury, Dorset. *British Geological Survey Technical Report*, WN/91/9.
- GRAINGER, P, TUBB, C D N, and NEILSON, A P M. 1985. Landslide activity at the Pinhay water source, Lyme Regis. *Proceedings of the Usher Society*, Vol. 6, 246–252.
- GRIM, R E. 1962. Applied clay mineralogy. (New York: McGraw-Hill.)
- HALLAM, J H. 1990. The statistical analysis and summarisation of geotechnical databases. *British Geological Survey Technical Report*, WN/90/16.
- HAMBLIN, R J O. 1968. Results of mapping the Haldon Hills. *Proceedings of the Ussher Society*, Part 1, 21–22.
- HAMBLIN, R J O. 1972. Tertiary structure of the Haldon Hills. *Proceedings of the Ussher Society*, Part 5, 442–447.
- HANCOCK, J M (compiler). 1965. The Gault of the Weald (symposium compilation). *Proceedings of the Geologists Association*, Vol. 76, 243–261.
- HART, M B, and WILLIAMS, C L. 1990. The Upper Greensand in east Devon: new data but old problems. *Proceedings of the Usher Society*, Vol. 7, 273–278.
- HEAD, K H. 1986. *Manual of soil laboratory testing. Effective Stress Tests*, Vol. 3. (London: Pentech Press.)
- HIGGINBOTTOM, I E, and FOOKES, P G. 1971. Engineering aspects of periglacial features in Britain. *Quarterly Journal of Engineering Geology*, Vol. 3, 85–117.
- HOBBS, P R N. 1990. Fieldwork at Selbourne, Hampshire. *British Geological Survey Technical Report*, WN/91/2.
- HOBBS, P R N, YEOW, H, HORSEMAN, S T, and JACKSON, P D. 1982. Swelling properties of the mudrocks at Harwell. *Report of the Institute Geological Sciences*, ENPU 82-11.
- HOLTZ, W G, and GIBBS, H J. 1956. Engineering properties of expansive clays. *Transactions of the American Society of Civil Engineers*, Vol. 121, 641–663.
- HORSEMAN, S T, HOBBS, P, MCEWAN, T J, AVERY, L, and FORSTER, A. 1982. Basic geotechnical properties of core from the Harwell boreholes. *Report of the Institute Geological Sciences*, ENPU 82-7.
- HOULSBY, G T, and WITHERS, N J. 1988. Analysis of the cone pressure meter test in clay. *Geotechnique*, Vol. 38, No. 4, 575–587.
- HUMPHRIS, C J. 1979. An account of the geomorphology and mechanics of a failure of a stretch of coastal cliffs between Blackgang and St Catherine's Point, Isle of Wight. Unpublished BSc project. Kingston Polytechnic.

- HUTCHINSON, J N. 1969. A reconsideration of the coastal landslides at Folkestone Warren, Kent. *Geotechnique*, Vol. 19 (1), 6–38.
- HUTCHINSON, J N. 1988. General report: Morphological and geotechnical parameters of landslides in relation to geology and hydrogeology. *5th International Symposium on Landslides, Lausanne*, Vol. 1, 3–35
- HUTCHINSON, J N, BROMHEAD, E N, and CHANDLER, M P. 1991. Investigations at St. Catherine's point, Isle of Wight. *Slope stability engineering*. (London: Thomas Telford for Institution of Civil Engineers.) 169–179.
- HUTCHINSON, J N, BROMHEAD, E N, and LUPINI, J F. 1980. Additional observations on the Folkestone Warren landslides. *Quarterly Journal of Engineering Geology*, Vol. 13, 1–31.
- HUTCHINSON, J N, CHANDLER, M P, and BROMHEAD, E N. 1981. Cliff Recession on the Isle of Wight southwest coast. *Proceedings of the 10th International Conference on Soil Mechanics and Foundation Engineering*, Vol. 1, 429–434.
- HYDE, R B, and LEACH, B A. 1975. Settlement at Didcot Power Station. *Proceedings of the Conference Settlement of structures, Cambridge*. (Pentech Press: British Geotechnical Society.) 169–176.
- JEANS, C V. 1978. Silicification and associated clay assemblages in the Cretaceous Marine sediments of southern England. *Clay Minerals*, Vol. 13, 101–126.
- JEANS, C V M, MERRIMAN, R J, MITCHELL, J G, and BLAND, D J. 1982. Volcanic Clays in the Cretaceous of Southern England and Northern Ireland. *Clay Minerals*, Vol. 17, 105–156.
- JUKES-BROWN, A J. 1900. The Cretaceous Rocks of Britain. 1 The Gault and Upper Greensand of England. *Memoir of the British Geological Survey*. (London: HMSO.) 1–499
- KAY, J N, and PARRY, R H G. 1982. Screw plate tests in a stiff clay. *Ground Engineering*, September, 22–30.
- LAKE, R D, YOUNG, B, WOOD, C J, and MORTIMORE, R N. 1987. The Geology of the country around Lewes. *Memoirs of the British Geological Survey*. (London: HMSO.)
- LANG, W D. 1914. The Geology of the Charmouth Cliffs, Beach and Foreshore. *Proceedings of the Geologists Association*, Vol. 25, 293–360
- LEA, F M. 1970. The chemistry of cement and concrete, 3rd Edition. (London: Edward Arnold.)
- LOVELAND, P J. 1984. The soil clays of Great Britain: I. England and Wales. *Clay Minerals*, Vol. 19, 681–707.
- MADSEN, F T, and MULLER-VONMOOS, M. 1985. Swelling pressures calculated from mineralogical properties of Jurassic Opalinum Shale, Switzerland. *Clays and Clay Minerals*, Vol. 33, 501–509.
- MARSH, A H, and GREENWOOD, N R. 1995. Foundations in Gault clay. *Engineering Geology Special Publication of the Geological Society*, No. 10: Engineering Geology of Construction.
- MARSLAND, A, and POWELL, J J M. 1990. Pressure meter tests on stiff clays and soft rocks: factors affecting measurements and their interpretation. *Engineering Geology Special Publication of the Geological Society*, No. 6: Field testing in Engineering Geology, 91–110.
- MATTHEWS, G A. 1977. Geological and geotechnical report on south east Isle of Wight: geotechnical study of the eastern extremity of the Undercliff (the Landslip). Unpublished BSC project report. Portsmouth Polytechnic.
- MCCANN, D M, and FORSTER, A. 1990. Reconnaissance geophysical methods in landslide investigations. *Engineering Geology*, Vol. 29, 59–78. (Amsterdam: Elsevier.)
- MCRAE, S G, and LAMBERT, J L M. 1968. A study of some glauconites from Cretaceous and Tertiary formations in southeast England. *Clay Minerals*, 7, 431–439.
- MILODOWSKI, A E, and WILMOT, R D. 1985. Mineralogy and petrography studies of Jurassic and Cretaceous sediments from southern England and their relevance to waste disposal. *Mineralogical Magazine*, Vol. 49, 255–263.
- MILODOWSKI, A E, MARTIN, B A, and WILMOT, R D. 1982. Petrography of the Cretaceous core from the Harwell Research Site. *British Geological Survey ENPU Report*, 82-14.
- MORRIS, D V, and ABBIS, C P. 1979. Static modulus of Gault clay predicted from seismic tests. *Ground Engineering*, Vol. 12 No. 8, 44–51.
- MORTER, A A. 1982. In RHYS, G H, LOTT, G K, and CALVER, M A (editors) 1982. The Winterbourne Kingston borehole, Dorset, England. *Report of the Institute of Geological Sciences*, 81/3
- NEWMAN, R L. 1985. Geological and geotechnical considerations associated with some sections of the M25 construction. *Quarterly Journal of Engineering Geology*, Vol. 18, 149–160.
- OSBOURNE-WHITE, H J. 1913. The Geology of the country around Farnham and Havant. *Memoirs of the Geological Survey of Great Britain*. (London: HMSO.)
- OWEN, H G. 1958. Lower Gault sections in the northern Weald and the zoning of the Lower Gault. *Proceedings of the Geologists Association*, Vol. 69, No. 3, 148–165.
- OWEN, H G. 1960. The Gault-Lower Greensand junction and the Lower Gault of the Maidstone by-pass (east section), Kent. *Proceedings of the Geologists Association*, Vol. 71, No. 4, 364–378.
- OWEN, H G. 1971. The Stratigraphy of the Gault in the Thames Estuary and its Bearing on the Mesozoic Tectonic History of the area. *Proceedings of the Geologists Association*, Vol. 82, 187–207
- OWEN, H G. 1972. The Gault and its junction with the Woburn Sands in the Leighton Buzzard area, Bedfordshire and Buckinghamshire. *Proceedings of the Geologists Association*, Vol. 83, No. 3, 287–312.
- OWEN, H G. 1975. The stratigraphy of the Gault and Upper Greensand of the Weald. *Proceedings of the Geologists Association*, Vol. 86, 475–499
- PARRY, R H G. 1988. Short term slipping of a shallow excavation in Gault clay *Proceedings of the Institution of Civil Engineers*, part 1, 84, 337–353.
- PARSON, A W, and PERRY, J. 1985. Slope stability problems in ageing highway earthworks. *Failures in Earthworks*. (London: Thomas Telford Ltd.)
- PERRIN, R M S. 1957. The clay mineralogy of some tills in the Cambridge district. *Clay Mineralogy*, Bv 3 (8), 193–205.
- PERRIN, R M S. 1971. The clay mineralogy of British Sediments. Mineralogical Society, London.
- PERRY, J. 1989. A survey of slope condition on motorway earthworks in England and Wales. *Transport and Road Research Laboratory*, Report 199.
- PRIOR, S V, KEMP, S J, PEARCE, J M, and INGLETHORPE, S D J. 1993. Mineralogy of the Gault clay from the Arlesey and Klondyke Farm boreholes. *British Geological Survey Technical Report*, WG/93/17.
- RANKIN, W J, and CANN, J. 1992. The use of downhole geophysics for correlating geotechnical properties of the Chalk Marl and Gault clay. *Engineering Geology Special Publication of the Geological Society*, No. 8: Engineering Geology of Weak Rocks.
- REID, C. 1898. The Geology of Eastbourne. *Memoirs of the Geological Survey of Great Britain*. (London: HMSO.)
- REID, C. 1903. The Geology of Chichester. *Memoirs of the Geological Survey of Great Britain*. (London: HMSO.)
- RHYS, G H, Lott, G K, and CALVER, M A (editors). 1982. The Winterbourne Kingston borehole, Dorset, England. *Report of the Institute of Geological Sciences*, 81/3

- ROWE, R K, and NADARAJAH, P. 1993. Evaluation of the hydraulic conductivity of aquitards. *Canadian Geotechnical Journal*, Vol. 30, 781–800.
- RUFFELL, A H. 1991. Geophysical correlation of the Aptian and Albian formations in the Wessex Basin of southern England. *Geological Magazine*, Vol. 128, 67–75.
- SAMUELS, S G. 1975. Some properties of the Gault clay from the Ely–Ouse Essex Water Tunnel. *Geotechnique*, Vol. 25, No. 2, 239–264.
- SEED, H B, WOODWARD, R J, and LUNDGREN, R. 1964. Clay mineralogical aspects of the Atterberg limits. *Proceedings of the American Society of Civil Engineers, Journal of the Soil Mechanics and Foundation Division*, Vol. 90, No. SM4 July, 107–130.
- SELLWOOD, B W, and SLADEN, C P. 1981. Mesozoic and Tertiary argillaceous units: distribution and composition. *Quarterly Journal of Engineering Geology*, Vol. 14, 263–275.
- SHAW, H F. 1981. Mineralogy and petrology of the argillaceous rocks of the U.K. *Quarterly Journal of Engineering Geology*, Vol. 14, 277–290.
- SHERIFF, E R. 1984. *Encyclopedic Dictionary of Exploration Geophysics*. Society of Exploration Geophysicists. Tulsa, Oklahoma, USA.
- SHERLOCK, R L. 1960. *British Regional Geology London and the Thames Valley regional guide*. (London: HMSO.)
- SKEMPTON, A W. 1953. The colloidal "activity" of clay. *Proc. Third International Conference on Soil Mechanics*, Vol. 1, 57–61.
- SKEMPTON, A W, and DE LORY, F A. 1957. Stability of natural slopes in London Clay. *Proceedings of the Fourth International Conference on Soil Mechanics and Foundation Engineering, London*, Vol. 2, 378–381.
- SKEMPTON, A W, SCHUSTER, R L, and PETLEY, D F. 1969. Joints and fractures in the London Clay at Wragsby and Edgeware. *Geotechnique*, Vol. 19, 205–217.
- SMART, J G O, SABINE, P A, and BULLERWELL, W. 1964. The geological exploratory borehole at Canvey Island, Essex. *Bulletin of the Geological Survey of Great Britain*, Vol. 21, 1–37.
- SMART, J G O, BISSON, G, and WORSSAM, B C. 1966. Geology of the country around Canterbury and Folkestone. *Memoirs of the Geological Survey of Great Britain*, Sheets 289, 305 and 306.
- THURRELL, R G, WORSSAM, B C, and EDMONDS, E A. 1968. The geology of Haslemere. *Memoirs of the Geological Survey of Great Britain*. (London: HMSO.)
- TOMS, A H. 1953. Recent research into the coastal landslides at Folkestone Warren, Kent, England. *Proceedings of the 3rd International Conference on Soil Mechanics*, Vol. 2, 288–293.
- TRESISE, G R. 1961. The Nature and Origin of Chert in the Upper Greensand of Wessex. *Proceedings of the Geologists Association*, Vol. 72, 333–357.
- VARLEY, P, DARBY, A, and RADCLIFFE, E. 1993. Geology, alignment, and survey. In: *The Channel Tunnel. Proceedings of the Institution of Civil Engineers*, part 1, 43–54.
- WAGNER, A A. 1957. The use of the Unified Soil Classification System for the Bureau of reclamation. *Proceedings of the 4th International Conference on Soil mechanics and Foundation Engineering, London*, Vol. 1, 125–134.
- WEST, R G. 1972. Relative land-sea level changes in southeast England during the Pleistocene. *Philosophical Transactions of the Royal Society, London*, A 272, 87–98.
- WHITE, H J O. 1910. The geology of the country around Arlesford. *Memoirs of the Geological Survey of Great Britain*. (London: HMSO.)
- WILKINSON, I P. 1991. Micropalaeontology of the Lower Cretaceous deposits of the Church Farm No. 2 borehole, Shaftesbury. *British Geological Survey Report*, WH/91/72R.
- WILMOT, R D, and MORGAN, D J. 1982. Mineralogical and litho-chemical studies of strata beneath the Harwell Research site. *British Geological Survey ENPU Report*, 82–13.
- WOODS, A M M. 1955. Folkestone Warren Landslips: investigations 1948–50. *Proceedings of the Institution of Civil Engineers*, Railway Paper 56, 410–428.
- WOODS, M A. 1992a. Biostratigraphical interpretation of the Cretaceous macrofaunas of the Arlesey Borehole. *British Geological Survey Technical Report*, WH/92/83/R.
- WOODS, M A. 1992b. Preliminary biostratigraphic interpretation of the Gault of the Klondyke Farm Borehole. *British Geological Survey Technical Report*, WH/92/264/R.
- YOUNG, B, and LAKE, R D. 1988. The geology of the country around Brighton and Worthing. *Memoirs of the Geological Survey of Great Britain*. (London: HMSO.)

PROJECT REPORTS

TECHNICAL REPORTS

Landslipping and slope development around Shaftesbury, Dorset. By T P Gostelow (In: Geological notes and local details of 1:10 000 sheets East-Stour, Shaftesbury 82SW-82SE, by Bristow et al., BGS Report WA89/58). BGS Report WN/89/3.

Mineralogy and petrology of borehole samples taken from landslipped Gault clay, Shaftesbury, Dorset. By A J Bloodworth. BGS Report WG/90/36.

Fieldwork at Selbourne, Hampshire. By P R N Hobbs. BGS Report WN/91/2.

Micropalaeontology of the Lower Cretaceous deposits of Church Farm No. 2 Borehole, Shaftesbury. By I P Wilkinson. BGS Report WH/91/72R.

Geological processes and their effect on the engineering behaviour of the Gault clay and Upper Greensand; an example from Shaftesbury, Dorset. By T P Gostelow. BGS Report WN/91/9. (Contribution to "The geology of the country around Shaftesbury. Explanation of 1:50 000 geological sheet 313. Bristow et al., in press.)

Swelling and shrinkage characteristics of Gault clay. By A T M Shakhawat. MSc dissertation, Dept of Earth Sciences and Civil Engineering, University of Leeds. 1992.

Preliminary report on the correlation of geophysical wireline borehole logs in the U.K. By A C Cripps. BGS report WN/92/12.

The geotechnical properties of the Gault clay near Thame Oxfordshire and their implications for engineering. By A Forster. BGS Report WN/92/13.

Biostratigraphical interpretation of the Cretaceous macrofaunas of the Arlesey Borehole. By M A Woods. BGS technical report WH/92/83/R.

Preliminary biostratigraphic interpretation of the Gault of the Klondyke Farm Borehole. By M A Woods. BGS technical report WH/92/264/R.

Mineralogy of the Gault clay from the Arlesey and Klondyke Farm Boreholes. By S V Prior, S J Kemp, J M Pearce, and S D J Inglethorpe. BGS Report WG/93/17.

The Hydrogeology of the Gault clay. By S M M Fenwick. BGS Report No. WN/94/6.

The mineralogy of the Gault clay. By D C Entwisle. BGS Report No. WN/94/8.

Geotechnical properties of the Gault clay. By P R N Hobbs and D C Entwisle. BGS Report No. WN/94/10.

Magnetic susceptibility correlations in the Gault clay boreholes at Arlesey and Klondyke Farm. By M G Raines. BGS Report No. WN/94/14.

LABORATORY REPORTS

BGS (EGGG) Laboratory Report No. 92/33 (1992) Determination of liquid, plastic, and linear shrinkage limits (Arlesey, Klondyke Farm boreholes) by T Grantham, Sept. 1992.

BGS (EGGG) Laboratory Report No. 92/36 (1992) Atterberg limits, particle size, and residual shear strength of borehole samples from two boreholes near Shaftesbury, Dorset by D C Entwisle, Dec. 1992.

BGS (EGGG) Laboratory Report No. 93/2 (1993) Residual shear strength of six samples from two boreholes, Arlesey, Bedfordshire and Klondyke Farm, Cambridgeshire by D C Entwisle, March 1993.

BGS (EGGG) Laboratory Report No. 93/4 (1993) The engineering geology of British soils and rocks. The Gault clay in

England. Particle size analysis and specific gravity testing by L Jones, March 1993.

BGS (EGGG) Laboratory Report No. 93/5 (1993) The engineering geology of British soils and rocks. The Gault clay in England. Consolidation of a sample from Klondyke Farm borehole, 6.77 m by D C Entwisle, April, 1993.

BGS (EGGG) Laboratory Report No. 93/6 (1993) The engineering geology of British soils and rocks. The Gault clay in England. Consolidation of a sample from Klondyke Farm borehole, 10.55 m by D C Entwisle, April, 1993.

BGS (EGGG) Laboratory Report No. 93/7 (1993) The engineering geology of British soils and rocks. The Gault clay in England. Consolidation of a sample from Arlesey borehole, 15.65 m by D C Entwisle, April, 1993.

BGS (EGGG) Laboratory Report No. 93/8 (1993) The engineering geology of British soils and rocks. The Gault clay in England. Consolidation of a sample from Klondyke Farm borehole, 14.45 m by D C Entwisle, June, 1993.

BGS (EGGG) Laboratory Report No. 93/9 (1993) The engineering geology of British soils and rocks. The Gault clay in England. Consolidation of a sample from Klondyke Farm borehole, 23.5 m by D C Entwisle, June, 1993.

BGS (EGGG) Laboratory Report No. 93/10 (1993) The engineering geology of British soils and rocks. The Gault clay in England. Consolidation of a sample from Klondyke Farm borehole, 27.0 m by D C Entwisle, June, 1993.

BGS (EGGG) Laboratory Report No. 93/11 (1993) The engineering geology of British soils and rocks. The Gault clay in England. Consolidation of a sample from Arlesey borehole, 37.45 m by D C Entwisle, June, 1993.

BGS (EGGG) Laboratory Report No. 93/12 (1993) The engineering geology of British soils and rocks. The Gault clay in England. Consolidation of a sample from Arlesey borehole, 46.39 m by D C Entwisle, June, 1993.

BGS (EGGG) Laboratory Report No. 93/13 (1993) The engineering geology of British soils and rocks. The Gault clay in England. Consolidation of a sample from Arlesey borehole, 55.52 m by D C Entwisle, June, 1993.

BGS (EGGG) Laboratory Report No. 93/17 (1993) The engineering geology of British soils and rocks. The Gault clay in England. Multi-stage effective stress triaxial testing of Klondyke Farm borehole, 6.77 m by D C Entwisle, Oct. 1993.

BGS (EGGG) Laboratory Report No. 93/18 (1993) The engineering geology of British soils and rocks. The Gault clay in England. Multi-stage effective stress triaxial testing of Klondyke Farm borehole, 10.5 m by D C Entwisle, Oct. 1993.

BGS (EGGG) Laboratory Report No. 93/19 (1993) The engineering geology of British soils and rocks. The Gault clay in England. Multi-stage effective stress triaxial testing of Klondyke Farm borehole, 14.5 m by D C Entwisle, Oct. 1993.

BGS (EGGG) Laboratory Report No. 93/20 (1993) The engineering geology of British soils and rocks. The Gault clay in England. Multi-stage effective stress triaxial testing of Klondyke Farm borehole, 23.5 m by D C Entwisle, Oct. 1993.

BGS (EGGG) Laboratory Report No. 93/21 (1993) The engineering geology of British soils and rocks. The Gault clay in England. Multi-stage effective stress triaxial testing of Klondyke Farm borehole, 27.0 m by D C Entwisle, Oct. 1993.

BGS (EGGG) Laboratory Report No. 93/22 (1993) The engineering geology of British soils and rocks. The Gault clay in England. Multi-stage effective stress triaxial testing of Arlesey borehole, 35.45 m by D C Entwisle, Oct. 1993.

APPENDIX 1

REGIONAL GEOPHYSICAL BOREHOLE LOG CORRELATIONS

Borehole geophysical well-logs are a proven technique of long-distance lithological correlation and this method has been applied to the Albian, using the natural gamma logs (Figure 1). At only one site (Lomer, SU 5959 2356) are the effects of faulting obvious as illustrated by comparison of the Lomer and Horndean boreholes (Figure 2). In this case, it appears that two faults are present which effect the Albian; the lower cuts out the majority of the Gault and possibly the lowest beds of the Upper Greensand, whilst the upper has removed approximately 15 m from the top of the Upper Greensand together with part of the Glauconite Marl (the basal Cenomanian is only half as thick as it is elsewhere).

East Anglia

Two north-south comparative sections have been erected for East Anglia and the Thames Valley. The westernmost, from Hunstanton through Tring to Maddle Farm, (11 km south-west of Wantage) approximately follows the Albian outcrop (Figure 3) whilst along the line of the second, from South Creake to Canvey Island, the Albian is present beneath other formations (Figure 4).

The comparative plot for the western section (Figure 3) shows:

- a) Rapid thinning northwards between the Arlesey and Klondyke Farm boreholes, primarily of the central part of the formation. Further thinning occurs north of Lakenheath.
- b) Zonal evidence from the Klondyke Farm cored borehole indicates this reduction in thickness may be the result of a combination of a decrease in sediment deposition rate and an increase in intraformational erosion. This is supported by comparison with the Arlesey borehole log which shows a thinning above the level of Bed 15 from 36 m to 9 m and a reduction from 21 m to 2 m above Bed 17, suggesting considerable pre-Chalk erosion.
- c) Between Gayton and Hunstanton there is a facies change from clays to ferruginous carbonates of the Red Chalk.
- d) Correlation with the Tring borehole is by log feature identification from Arlesey and from Harwell to the south-west.
- e) The Arlesey borehole collapsed at a depth of 69 m before logging which cut off the lowermost 4.5 m of the Lower Gault. The level of the base has been fixed from the observed base in the core.
- f) The Cambridge and Soham boreholes are sited on the Albian outcrop (with thin Drift cover) hence the upper part of the sequences are missing.
- g) The presence of the Upper Greensand to the south-west of Tring.

For the central East Anglian section the correlation plot (Figure 4) shows:

- a) South of the Ellingham borehole the Carstone below the Gault is absent, with Gault resting directly on the Palaeozoic basement of the Anglo-Brabant massif.
- b) Core from the Canvey Island borehole shows the Lower Gault to be limited to a few centimetres of marginal facies sediment (Smart et al., 1964)

- c) The overall sequence is much thinner and of more constant thickness than shown in the western section. However, north of Breckles, on the Lcxham log there is a localised thickening which particularly affects the upper divisions.
- d) At South Creake evidence from lithological cuttings indicates the presence of Upper Greensand above Red Chalk and the gamma log indicates the latter to be considerably thicker than at Hunstanton.

Berkshire/North Downs section

The correlation section (Figure 5) indicates the presence of Lower Gault in the group of boreholes drilled by the Gas Council in the early 1960's at Cliffe-at-Hoo. These boreholes are approximately 15 km to the south-west of the Canvey Island Borehole, (where the Lower Gault is virtually absent) and the successions in them are comparable to that seen at outcrop, approximately 10 km to the south. The rapid increase in the thickness of the Gault is assumed to be due to penecontemporaneous faulting affecting the rate of deposition. From lithological evidence from other boreholes (which lack geophysical logs) to the west and north, the Lower Gault is absent along the line of the Anglo-Brabant Massif, but appears preserved in down-faulted troughs against the older basement. These faults were probably active in the early part of the Upper Albian. A period of erosion, indicated by the formation of a dominant phosphatic nodule band marks the base of the Upper Gault.

The division of the Lower Gault at Warlingham is by extrapolation of the features from Cliffe-at-Hoo. The Upper Greensand is seen to thin to the east and is absent east of Warlingham, although the uppermost 4.3 m of the Albian are assigned to this unit in the Canvey Island borehole by Smart et al. (1964).

Sussex and Kent sections

- a) The borehole sections (Figure 6) demonstrate the thickening, and facies change to the Upper Greensand, to the west at the top of the Albian.
- b) The Glyndebourne borehole shows the Albian to be composed entirely of the Gault clay facies (Lake et al., 1987). However, the next location on the section, Stanmer, 10 km to the west, contains 41.22 m of Upper Greensand. A comparison of the logs from these sites, together with that from Middleton (37 km further west) is shown in Figure 7, and indicates that some of the gamma peaks can be traced from the clay and into the sand facies. The nature of these peaks is not known, but they may represent glauconite enriched bands. Those indicated on Figure 7 demonstrate the western continuation of lithostratigraphic features identified on the gamma log and are not drawn at chronostratigraphic zonal boundaries.
- c) The four log sections in Kent (Figure 8) are from coal exploration sites and no lithostratigraphic details exist. The log for Glyndebourne, 37 km to the west, is added for comparative purposes only.

Hampshire and Berkshire

The majority of the gamma log data for the sections in the Hampshire/Dorset/Berkshire area (Figures 9, 10 and 11) are obtained from hydrocarbon exploration sources.

The Albian, as a whole, is seen to thin to the south and south-west, the Gault in particular thins to the south-west, as shown in

Figures 9 and 10, whilst the Upper Greensand retains a fairly constant thickness. The Winterbourne Kingston borehole was drilled as a stratigraphic and geothermal testing facility and the thicknesses of the Albian units were determined from the borehole core, (Morter *in Rhys* et al., 1982). Other stratigraphic research sites are at Glyndebourne (Figure 6), which was drilled as a fully cored Albian (Gault clay) test and at Shrewton which was primarily targeted at the pre-Mesozoic basement, consequently no cores were taken in the Albian.

The log for Shrewton (Figure 11) indicates a starting point below the base of the Chalk. However, comparison of the trace with those from Farley and Lockerley suggests the gamma low seen at the top of the section at Shrewton is just below the Chalk. Therefore, the top of the Albian is placed at a depth of 182 m.

The boundaries on the Winterbourne Kingston section are based on those obtained from the core (Morter *in Rhys* et al., 1982). The boundary at 300 m (between the *dispar* and *inflatum* zones) is at the top of the Foxmould which is recognised at its outcrop as a distinctive sequence of glauconitic sands and sandstones. This level has been extrapolated to neighbouring sites and equates to the boundary of beds 16/17 of Owen (1975).

The base of the Albian is seen to overstep locally, but progressively to the south-west, from the Lower Greensand onto variable sections of the Upper Jurassic, mainly Kimmeridgian or Oxfordian argillites (Figures 9 and 10).

No logs have been found of the Albian south of the monocline on the Isle of Wight. However, the logs at the southern end of the section shown in Figure 11 indicate the Albian to be comparable to that seen to the west in the Isle of Purbeck (Figure 10)

Other areas

Other areas of Albian sediments occur outside the main line of outcrop, but owing to facies changes and a lack of availability of geophysical logs, these are not included in the correlation sections.

Small outliers form the Haldon Hills of south Devon (east of Dartmoor) and comprise a sequence, up to 80 m thick, of varying grain size sandstones, gravels and shell beds now recognised (Hamblin and Wood, 1976) as being of Upper Albian to Lower Cenomanian age. No logged borehole sections were available within these sands and correlation with the East Devon/West Dorset sections was only possible by partial ammonite zonation indicating that the lower sections — the Telegraph Hill and Woodland Sands units and the lower part of the Ashcombe Gravels — are of Upper Albian *dispar* Zone age. The location of the Albian/Cenomanian boundary is unclear, but probably occurs within the upper part of the Ashcombe Gravels or at the junction with these gravels and the overlying Cullum Sands.

The sequence northwards from the Wash through Lincolnshire is a continuation of the Red Chalk facies developed in northern Norfolk and is everywhere underlain by the Carstone. This shows a gradational boundary with the overlying unit as seen elsewhere beneath the clay facies (i.e. Gault). The Red Chalk reaches its maximum development of 8 m thickness in southern Lincolnshire and thins northwards.

Passing northwards the Carstone thins out over the Market Weighton axis and reappears beneath the Red Chalk with a gradational junction some 20 km north of the Humber: the Red Chalk continues unaffected across the Market Weighton axis. All the Lower Cretaceous deposits (a mixture of sandstones, ironstones, limestones and clays) have thinned out approximately 35 km north of the Humber. A further 15 km north-eastwards the Red Chalk reappears but is underlain by 90 m of clays (Speeton Clay) with a basal sandstone and intercalated limestone and ironstone beds. Approximately 1 m of banded clays above a non-sequence near the top of the Speeton Clay and immediately below the Red Chalk have been assigned to the Albian and possibly are the lateral equivalent of the Carstone.

DETAILS OF BOREHOLES USED IN THE COMPARATIVE SECTIONS

Location	NGR	Depth to top Albian (m)	Thickness Gault (m)	Thickness UGS (m)
Hunstanton	TF 6857 4078	18.25	1.85	absent
Gayton	TF 7280 1974	12.7	9.5	absent
Marham	TF 7051 0803	33.43	11.97	absent
Lakenheath	TL 7480 8300	66.4	20.2	absent
Soham	TL 5928 7448	4.0*	19.05*	absent
Klondyke Farm	TL 5940 7010	4.05	27.01	absent
Cambridge	TL 4316 5949	6.5*	37.75*	absent
Arlesey	TL 1887 3463	15.75	57.2	absent
Tring	SP 9121 1036	86.2	71.2	absent
South Creake	TF 8573 3402	160.85	3.36	3.13
Lexham	TF 7280 1974	170.5	26.0	absent
Ellingham	TM 0262 9847	267.5	10.8	absent
Breckles	TL 9551 9469	224.7	12.9	absent
Four Ashes	TM 0220 7180	266.7	13.35	absent
Stowlangtoft	TL 9480 6880	211.7	14.5	absent
Clare	TL 7898 4533	221.0	11.05	absent
Canvey Island	TQ 6903 8330	363.3	4.0	4.3
Cliffe at Hoo	TQ 6903 7711	209.39	59.84	absent
Harwell	SU 4676 8645	6.4	66.13	23.1
Aston Tirrold	SU 5579 8722	5.0	70.7	20.2
Maddle Farm	SU 3053 8233	103.7	66.2	20.3
Strat B	SU 6820 6520	308.	65.65	32.5
Hook Lane	SU 5754 5388	246.2	63.55	45.1
Stockbridge	SU 410 3550	222.89	64.19	47.47

* Data used by permission of British Petroleum plc.

Location	NGR	Depth to top Albian (m)	Thickness Gault (m)	Thickness UGS (m)
Lockerle	SU 3068 2591	412.95	48.15	42.65
Fordingbridge*	SU 1876 1180	610.7	29.68	8.82
Cranbourne	SU 0341 0907	443.0	39.5	31.6
Spetisbury	ST 8942 0230	296.6	38.6	41.9
Winterbourne Kingston	SY 8470 9790	289.8	21.32	34.5
Waddock Cross	SY 8035 9125	371.0	43.83	18.6
Wareham	SY 9059 7210	533.55	24.43	36.12
Wyth Farm	SY 0104 8574	578.7	25.55	33.4
Herriard	SU 6788 4655	212.3	74.6	34.1
Humbly Grove	SU 7115 4484	192.75	70.5	30.35
Strat A	SU 9480 5280	435.9	80.35	28.05
Stanwell	TQ 0648 740	306.15	76.0	11.35
Warlingham	TQ 4376 5719	124.7	88.68	12.5
Sandhills	SZ 4571 9085	1013.9	35.85	20.45
Cowes	SZ 5004 9417	922.3	36.94	21.36
Southampton	SU 4156 1202	575.05	39.63	30.28
Chilworth	SU 3928 1798	437.5	45.9	35.1
Farley	SU 2359 2853	438.55	49.7	45.85
Shrewton	SU 0314 4199	182.0	46.69	47.51
Horndean	SU 7154 1260	410.35	56.7	40.25
Middleton	SU 9745 0140	343.3	57.4	23.9
Stanmer	TQ 3263 1142	315.4	62.08	41.22
Glyndebourne	TQ 4421 1140	48.36	104.24	absent
Paddlesworth Court	TR 1990 4041	126.0	42.75	absent
Eastling Wood	TR 3033 4729	266.8	23.7	absent
Northwall Road	TR 3681 5356	216.8	29.05	absent
Swanton Court	TR 2387 443	248.15	12.25	absent

**BGS Technical
Report WN/94/31**

Engineering geology of British rocks and soils:
Gault clay