

CoA/NIM&P-15

CoA M and P Note No. 15

ST. N. R33532/A
U.D.C.
AUTH.



THE COLLEGE OF AERONAUTICS
CRANFIELD

DIMENSIONAL CHANGES RESULTING FROM THE
HEAT TREATMENT OF EN 30B AND NIMAR 125

by

C. F. Noble



R33532/A

3 8006 10057 9054

M and P Note No. 15

December, 1966

THE COLLEGE OF AERONAUTICS

DEPARTMENT OF PRODUCTION AND INDUSTRIAL ADMINISTRATION

Dimensional changes resulting from the
heat treatment of EN 30B and Nimar 125

- by -

C.F. Noble, D.C.Ae., C.Eng., A.M.I.Prod.E.



S U M M A R Y

Three components have been manufactured in both EN 30B and NIMAR 125. Dimensional changes following heat treatment have been recorded and, while the sample is only small, the report serves to illustrate the potential benefits which arise from the use of a maraging steel. NIMAR 125 is shown to have reasonably predictable dimensional characteristics and thus indicates the feasibility of completing all machining operations prior to heat treatment.

Acknowledgements

Professor J. Loxham has long been an advocate for finish heat treatment in lieu of finish machining and it is due to his enthusiasm and foresight in consultation with English Steel Corporation that this work was undertaken. The author records his thanks to Mr. W. Stalker, Metallurgy Department, Royal Aircraft Establishment, Farnborough, and to a number of colleagues at Cranfield - Mr. R. Sollars, Materials Department; Mr. L. Arkins, Metrology Laboratory and to workshop technicians who manufactured the components.

Contents

	<u>Page No.</u>
Summary	
Acknowledgements	i
Introduction	1
Material specifications	2
Method of heat treatment	3
Design of test pieces	4
Methods of measurement	4
Discussion of results - size and shape	5
Conclusions and comments	6
Figures	
Tabulated results	

Introduction

High strength to weight or volume is a permanent target in the aircraft industry and creates, perhaps, the most important impetus to continuous developments by the material manufacturers. However, other industries producing moving machinery are becoming increasingly aware of the benefits to be gained when designs incorporate high strength materials and consequently their future utilisation is guaranteed.

Machining such materials in the high strength condition usually necessitates a grinding operation which, without considerable care and control, induces damaging residual surface stresses and, perhaps, cracks. It is therefore desirable to avoid this finishing process by completing all machining operations prior to heat treating for maximum strength. Realisation of the technological and economic advantages offered by this sequence depends on the ability to precision machine components without grinding and to predict the dimensional changes which take place during subsequent heat treatment.

Use of quite simple control units and measuring instruments will permit precision machining operations on conventional machine tools and if only industry would act less conservatively quite considerable improvements could be made, even with standard materials. Dimensional changes during heat treatment, on the other hand, although explained by the metallurgist, await applied research programmes to furnish industry with accurate numerical facts for predictive purposes. Without these facts the application of high strength alloys is considerably hindered. The purpose of this modest report is to illustrate the practical feasibility of producing the necessary empirical data.

The experiments reported herein have been restricted to a comparison between the dimensional behaviour of a well established steel, EN 30B, and a recently developed maraging steel, NIMAR 125. Only a restricted sample of three specially designed components in each material is to be considered; consequently a comprehensive analysis is not contemplated. However, it is hoped that the results will serve to foster enthusiasm for more detailed work on the distortion of heat treatable metallic alloys and encourage conscious recognition by the metal manufacturers of the need for controllable characteristics.

Material Specifications

EN 30B - 4¹/₄ per cent Ni-Cr-Mo Steel.

Specification as per B.S. 970: 1955.

Chemical Composition, per cent.								
	C	Si	Mn	S	P	Ni	Cr	Mo
Min.	0.26	0.10	0.40			3.90	1.10	0.20
Max.	0.34	0.35	0.60	0.05	0.05	4.30	1.40	0.40
Heat-Treatment								
Harden from						810-830°C, quench in air [‡]		
Temper at						250°C max.		
Mechanical Tests								
Tensile Range Symbol	Limiting Ruling Section inch.	0.2 per cent. Proof Stress t.s.i.	Yield Point (not specified) t.s.i. min.	Maximum Stress t.s.i. min.	Elongation per cent min.	Izod Impact ft.lbs min.	Brinell Hardness (not specified) min.	
2	6	80	(85)	100	10	15	(444)	

[‡] For sizes larger than 2¹/₂ in. diameter it is preferable to oil-quench.

N.B. - When supplied in the 'softened' condition the Brinell hardness number should not exceed 285.

NIMAR 125 maraging steel, 2" diameter.

Specification as per English Steel Corporation Ltd., 5th February, 1965:-

Chemical Composition, per cent.											
Cast No.	C	Si	Mn	S	P	Ni	Cr	Mo	Co	Ti	Al
FZ.0036	.016	.07	.01	.007	.002	18.36	-	4.85	8.74	.68	.17

The material has been normalised at 820°C after forging. After machining the material will require ageing at 480°C for 3 hours, air cooled, to fully harden.

This should give the following longitudinal properties:-

Mechanical Tests			
0.2 per cent Proof Stress t.s.i.	Maximum Strength t.s.i.	$4\sqrt{A}$ Elongation per cent	Reduction in Area per cent.
119.2	127.2	10	32

Method of Heat Treatment

All the components were heated in a vacuum furnace and quenched in cold argon. This method prevented formation of oxide which would have rendered dimensional comparisons impossible.

Design of Test Pieces

The test pieces, Fig. 1 and 3, have been designed as hypothetical components having varying degrees of complexity. Distortion, either directly as a result of heat treatment or indirectly as a result of residual stress relief, will be most likely in the more complex component because it incorporates thin sections and abrupt changes in configuration. However, other general dimensional behaviour following a metallurgical phase change is expected to be the same in each part.

Methods of Measurement

External dimensions - mean measurements, external micrometer - hand

Internal dimensions - mean measurements, internal micrometer - hand

Flatness - Talyrond

Tilt - Talyrond

Squareness - Surface plate, angle plate, .0001 D.T.I.

Roundness - Talyrond

All components were 'soaked' in the Metrology Laboratory at 20°C before taking the measurements and subsequently handling was enacted with care.

Discussion of Results

Size - see tabulated results and Figure 2

There appears to be an unpredictable change in size with EN 30B, some dimensions exhibiting expansion while others exhibiting contraction.

The results for NIMAR 125 illustrate predictable shrinkage of .0007 inch/inch. The final dimensions so calculated should be within $\pm .0003$ inch. This tolerance may be larger than is necessary for, although considerable care was used by an experienced operator, a hand micrometer cannot be expected to realise the accuracy of more sensitive equipment. More sensitive equipment should be used for future work.

It is to be noted that although only two internal dimensions are included in the results the shrinkage for these appears to be less than for external dimensions. This may be due to non-uniformity in the heat treatment, a not un-expected characteristic with such configurations.

Shape

(i) Roundness - see tabulated results and Figures 4 and 5.

One of the EN 30B components exhibited an increase in out-of-roundness by as much as .0013 inch on a 1.35 inch diameter. Comparison between fig. 4 and fig. 5 illustrates the very much better general behaviour of NIMAR 125, the worst increase in out-of-roundness being only .0003 inch on a 1.0 inch diameter.

(ii) Squareness - see tabulated results.

The only component suitable for squareness measurement is D 6684 and the tabulated results indicate the improved behaviour of NIMAR 125 to that of EN 30B. The NIMAR 125 only loses .0001 inch compared with .0014 inch for EN 30B.

(iii) Tilt (parallelism) - see tabulated results

Tilt has only been measured on components D 6683 and D 6685. With Nimar 125, in one case it improved by .0005 inch and in the other it became worse by .0001 inch. With EN 30B, in one case it improved by .0005 inch and in the other it became worse by .0003 inch. There is therefore no real indication of a trend and no conclusion can be drawn.

(iv) Flatness - see tabulated results.

From the tabulated results for components D 6683 and D 6685 there appears to be slight improvement in flatness following heat treatment of both EN 30B and NIMAR 125. In the case of component D 6684, however, the presence of the eccentrically placed hole is detrimental to the flatness of the two surfaces parallel and in close proximity to the hole axis, but far less so with NIMAR 125 than EN 30B. The worst change with NIMAR is from .0002 inch to .0004 inch while with EN 30B is from .0001 inch to .0005 inch.

Conclusions and Comments

This work illustrates the potential benefits to the user of a maraging steel with characteristics similar to those of NIMAR 125. During heat treatment such a material behaves in a much more predictable manner than a more conventional high tensile material such as EN 30B.

Nimar 125 shrinks by 0.0007 inch per inch during heat treatment. With more extensive tests it should be possible to apply limits to this figure. Nevertheless, actual dimensions are shown to be within $\pm .0003$ inch of prediction while change in roundness is generally not more than $\pm .0002$ inch.

The number of results for squareness, tilt and flatness do not justify numerical conclusions but the few measurements taken indicate reasonable behaviour.

The use of a vacuum furnace with subsequent argon quenching proved satisfactory and similar methods for preventing oxidation will have to be used industrially if predictable dimensional performance is to be realised.

The designs presented in this document yield results of practical significance and it is the author's opinion that all future work in the field should include experiments on components with varying degrees of complexity. Furthermore, it would be preferable to establish standard test-piece designs in order that results from separate research and development can be directly compared.

High tensile metallic materials having controllable dimensional characteristics during heat treatment permit prior completion of all machining operations. It is therefore to be hoped that the enlightened materials manufacturer will be encouraged to carry out tests and include appropriate data in guaranteed specifications.

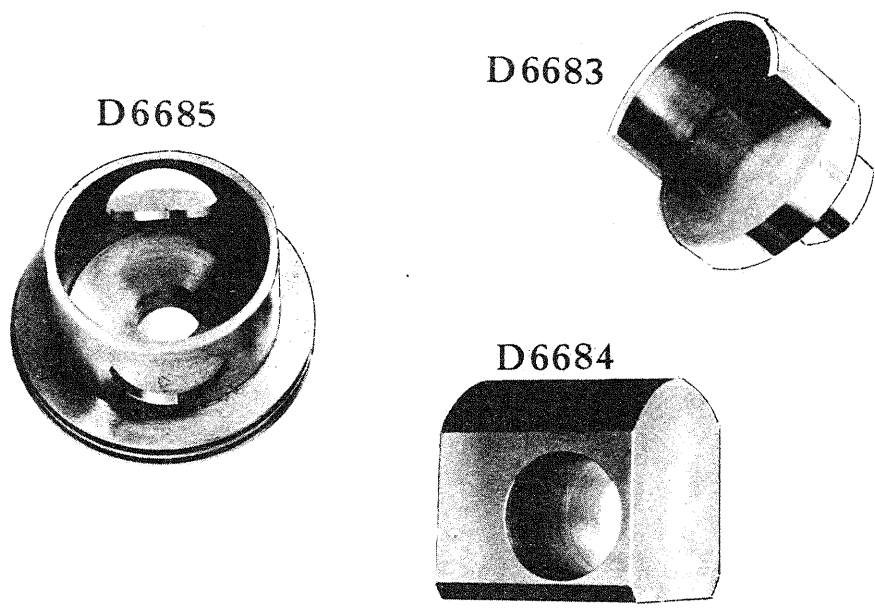

FIG. 1. PHOTOGRAPH OF THE THREE TYPES OF TEST PIECE

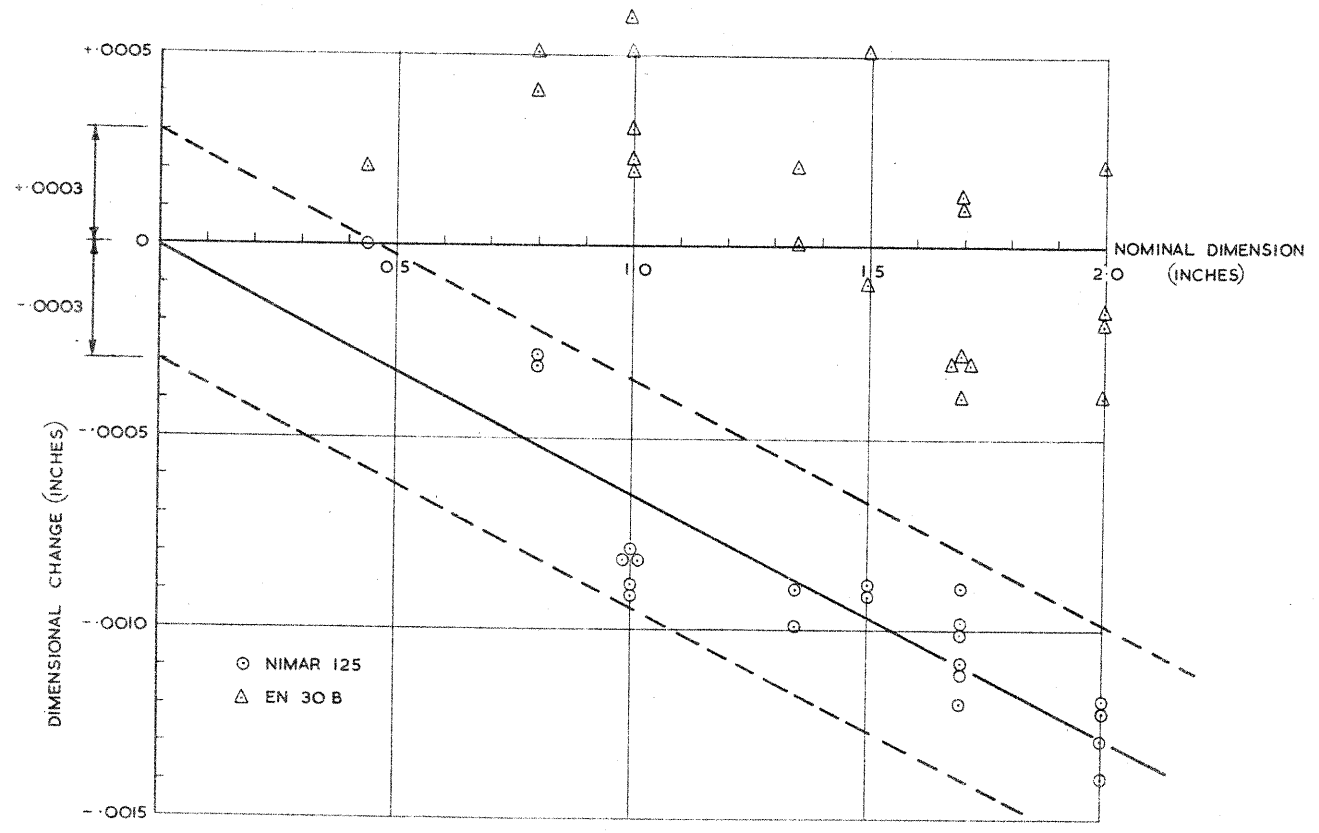
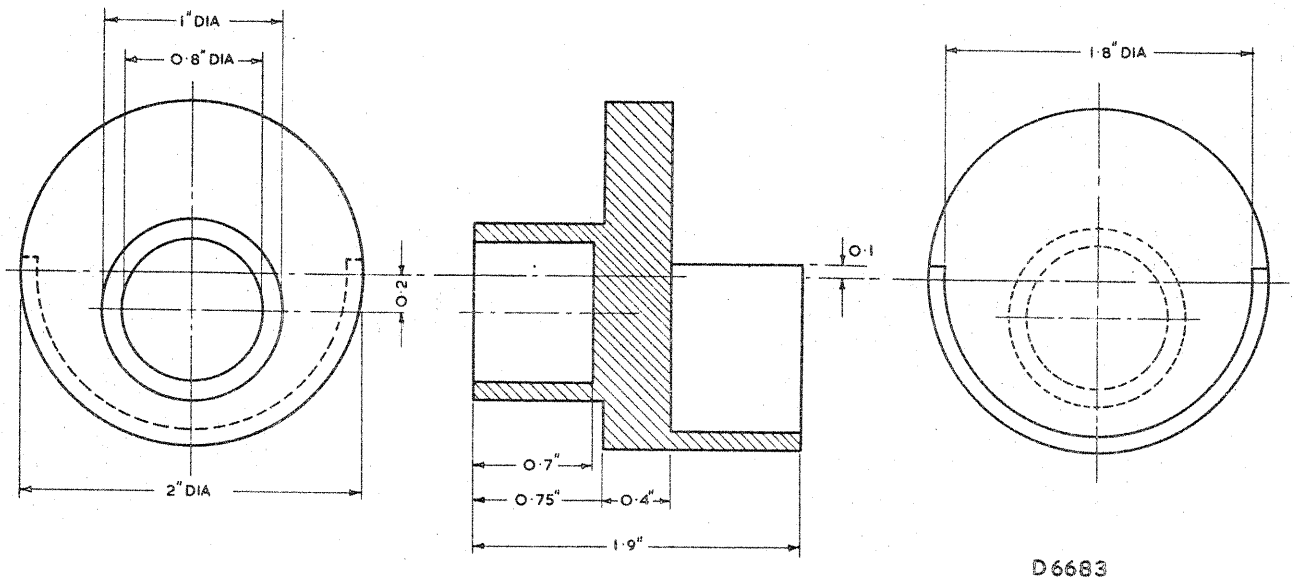
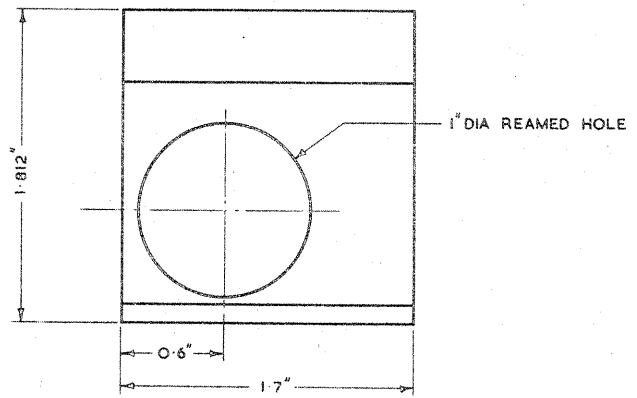
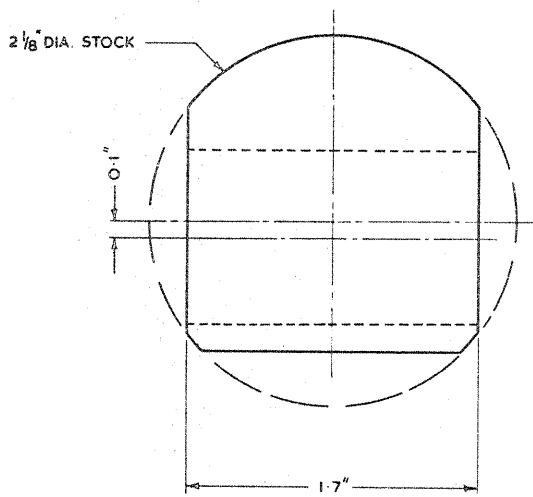

FIG. 2. DIMENSIONAL CHANGE vs NOMINAL DIMENSION.



D6683



D 6684

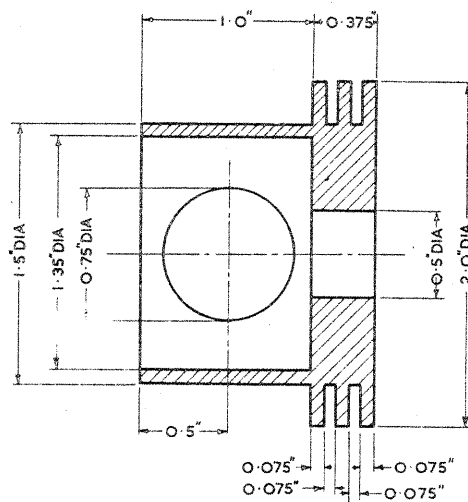
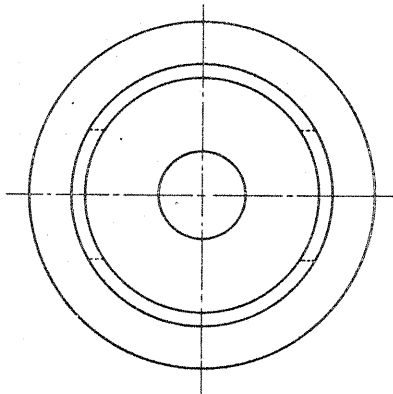

D6685

FIG.3. DETAIL DESIGN OF TEST PIECES.

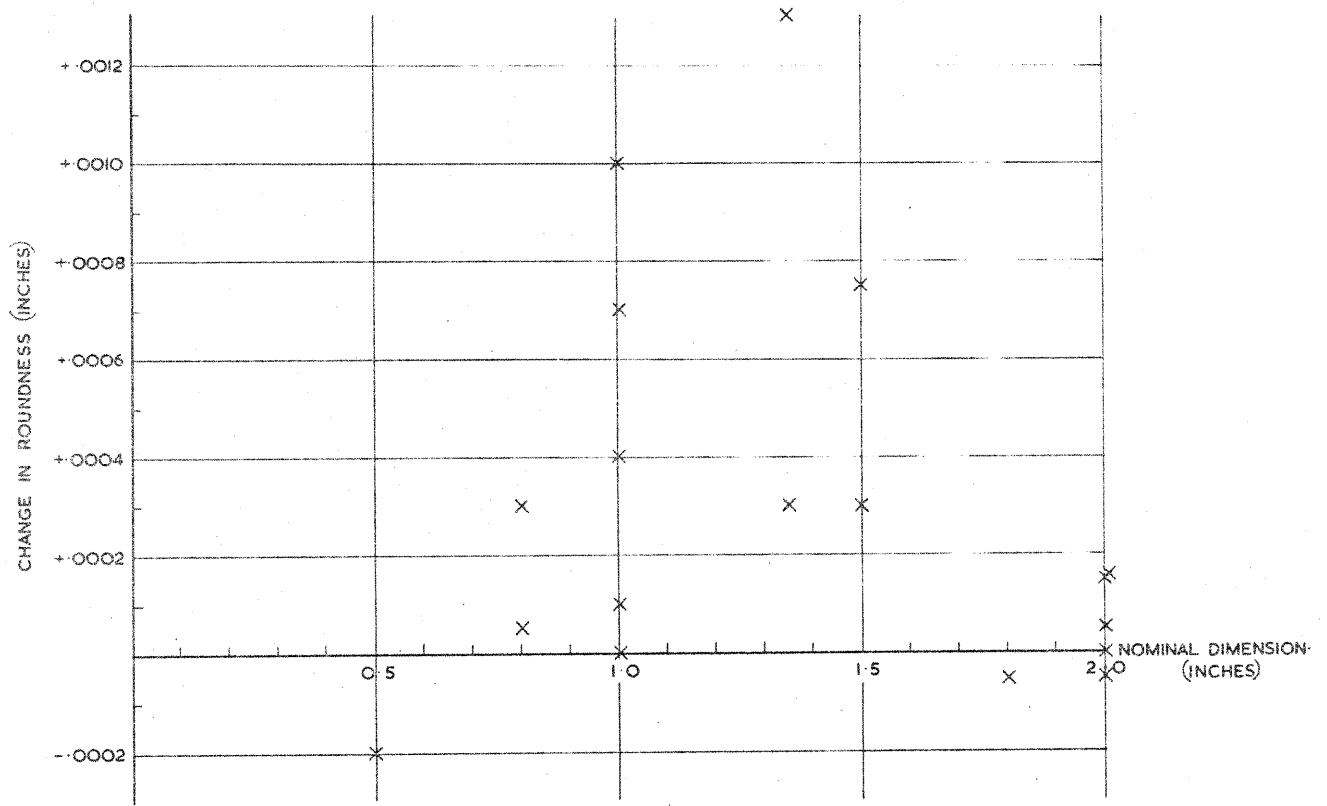

FIG.4. CHANGE IN ROUNDNESS vs NOMINAL DIMENSIONS FOR EN 30 B.

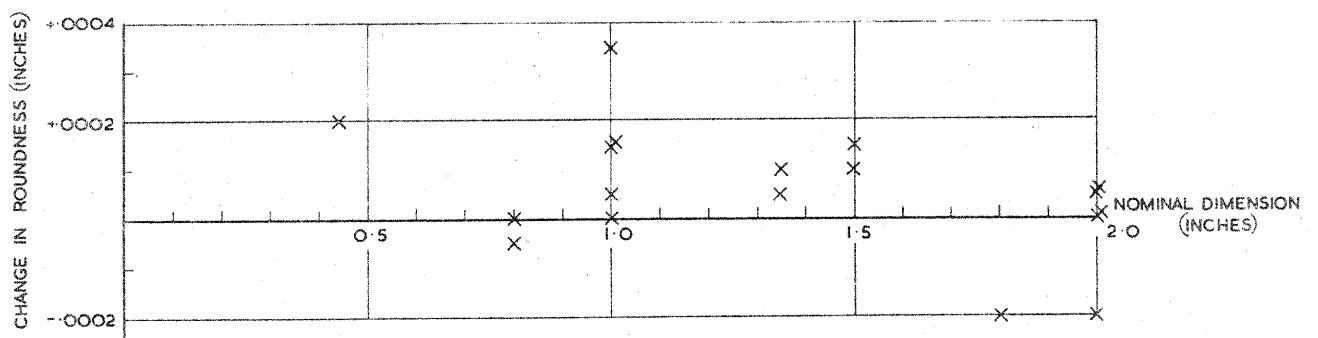
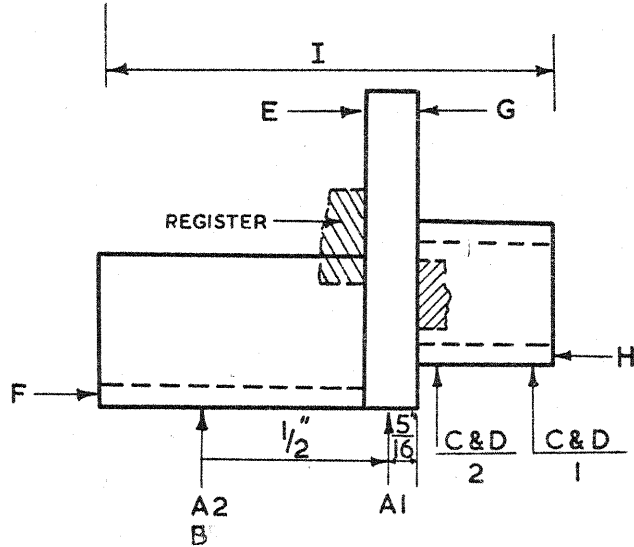
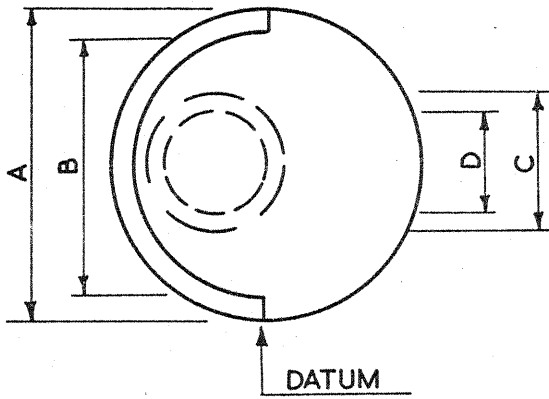

FIG.5. CHANGE IN ROUNDNESS vs NOMINAL DIMENSION FOR NIMAR 125.



Results from test piece D6683 before and after heat treatment

Nimar 125

E.N. 30B

Position	Size		Shape		Size		Shape	
	Before	After	Before	After	Before	After	Before	After
A 1	2.002"	2.0006"	E/C*	E/C*	1.9988"	2.0000"	E/C*	E/C*
A 2			0.0001"	0.0001"			0.0001"	0.00025"
B	1.8 nominal		0.001"	0.0003"			0.00025"	0.00025"
C 1	1.0003"	0.9994"	0.001"	0.0003"	0.9983"	0.9989"	0.0003"	0.00025"
C 2	1.0007"	0.9998"	0.0001"	0.00015"	0.9986"	0.9991"	0.0002"	0.0003"
D 1	0.7989"	0.7986"	0.0001"	0.0001"	0.8003"	0.8007"	0.0001"	0.0001"
D 2	0.7990"	0.7987"	0.0003"	0.00025"	0.8003"	0.8007"	0.0002"	0.0005"
			0.00015"	0.00015"	0.8000"	0.8005"	0.00015"	0.0002"
	<u>Flatness</u>		<u>Flatness</u>				<u>Flatness</u>	
E	Local		General				0.0005"	0.00025"
	0.006"	0.0035"	0.0010"	0.0001"				
			<u>Flatness</u>				<u>Flatness</u>	
F			0.0005"	0.0001"			0.0001"	0.0001"
	<u>Tilt</u>		<u>Flatness</u>		<u>Tilt</u>		<u>Flatness</u>	
G	0.0035"	0.0030"	0.0015"	0.0005"	0.0015"	0.0010"	0.00075"	0.0005"
	<u>Tilt</u>		<u>Flatness</u>		<u>Tilt</u>		<u>Flatness</u>	
H	0.002"	0.0015"	0.0010"	0.00075"	0.0008"	0.0007"	0.0003"	0.0002"
I	1.9027"	1.9018"			1.9005"	1.9009"		

*Enclosed circle

BEFORE

AFTER

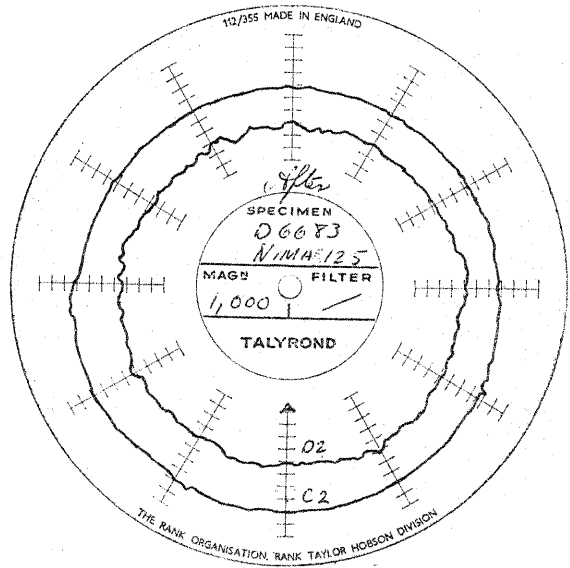
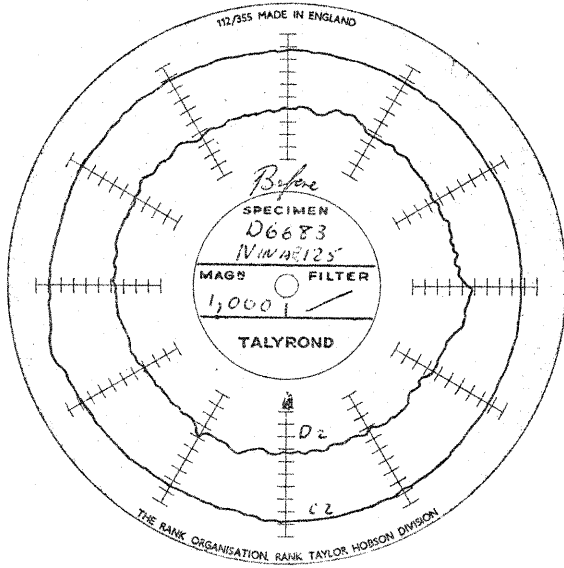
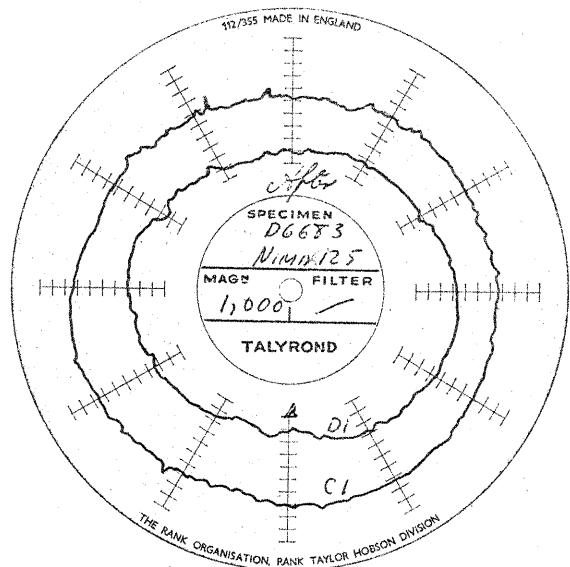
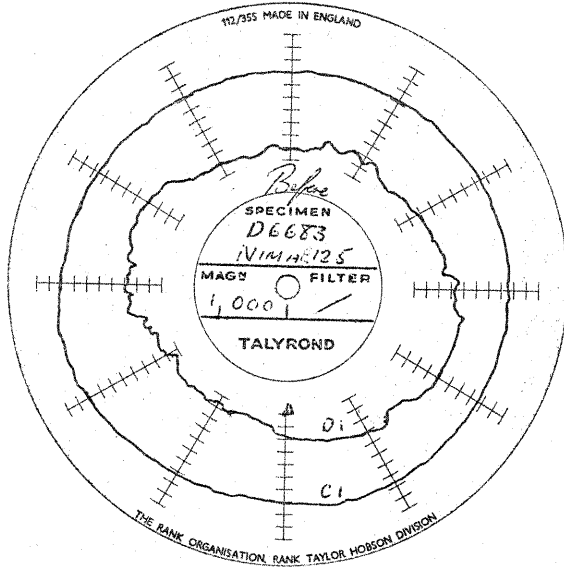
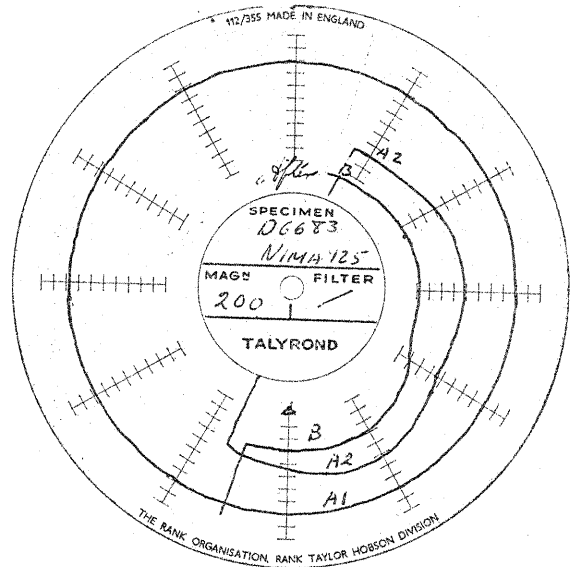
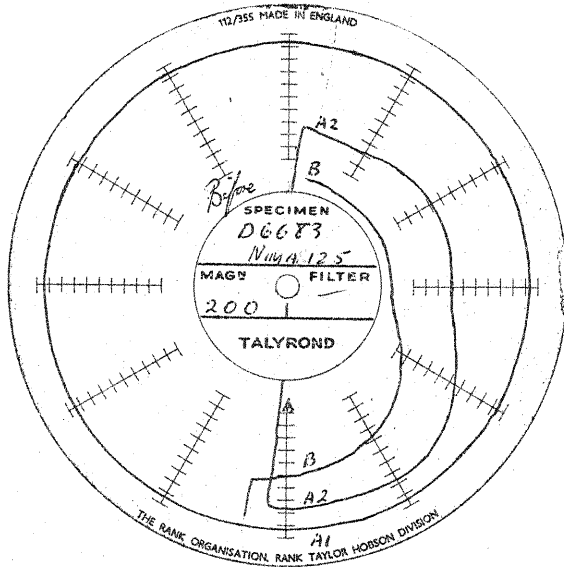

TALYROND RECORDINGS

NIMAR 125

BEFORE

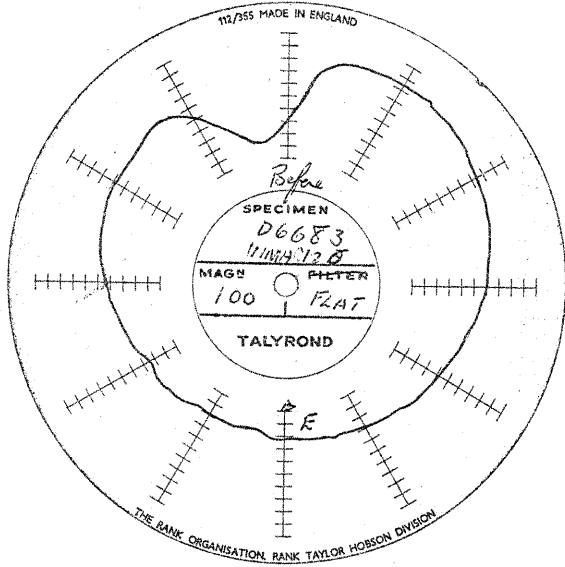

AFTER

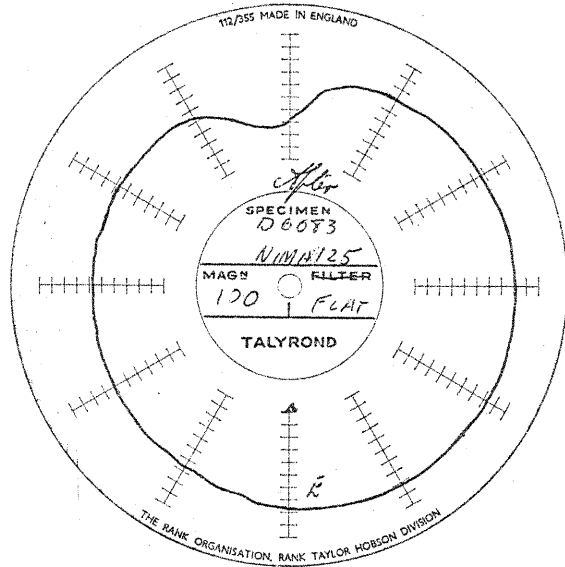

BEFORE

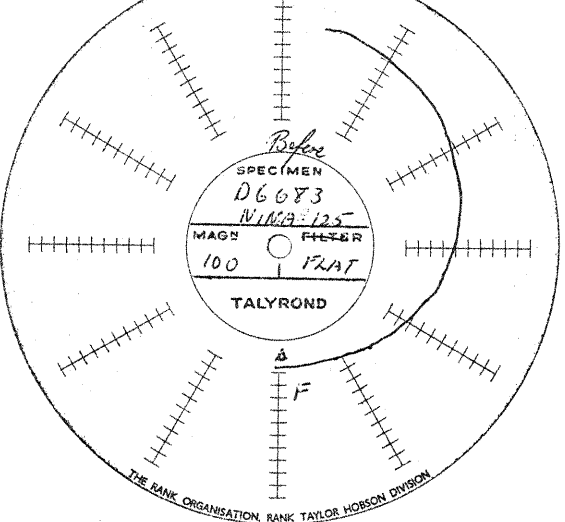

AFTER

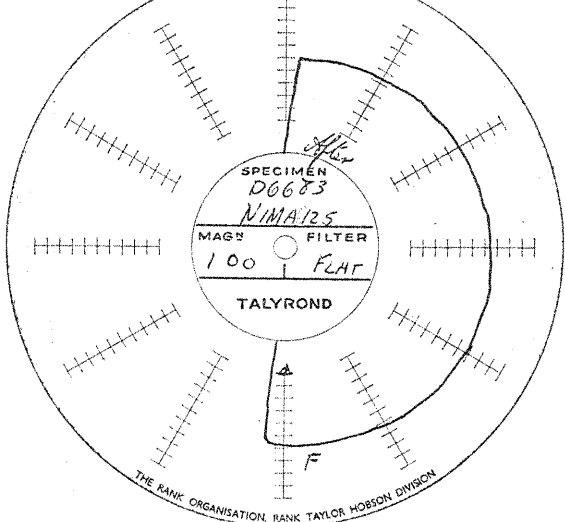

BEFORE

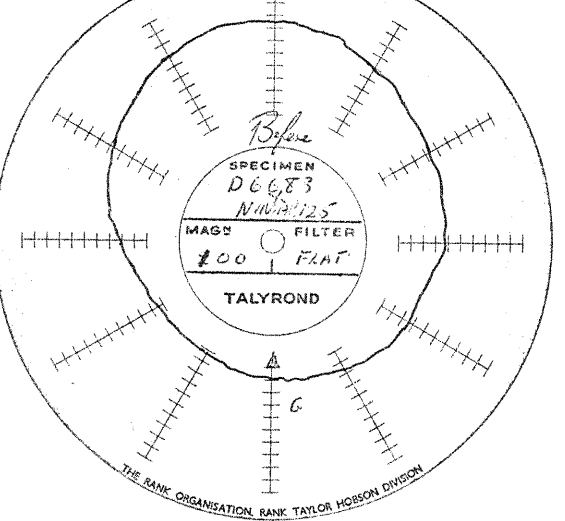

AFTER

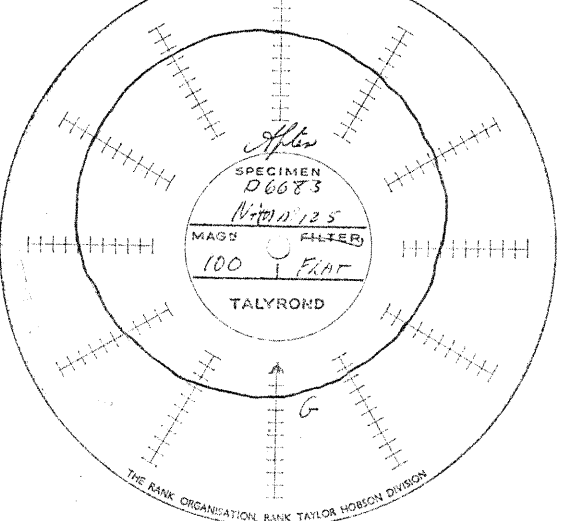

TALYROND RECORDINGS

NIMAR 125

BEFORE

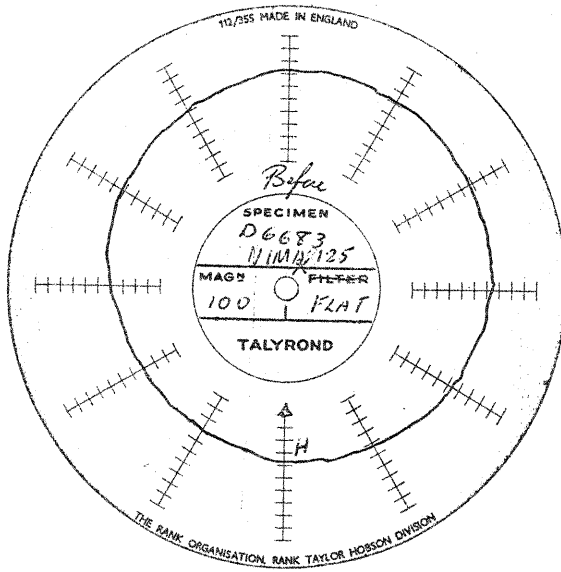

AFTER

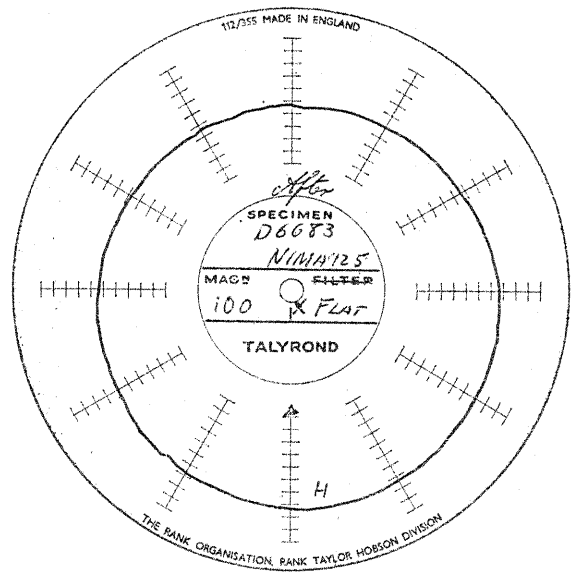

TALYROND RECORDINGS NIMAR 125

BEFORE

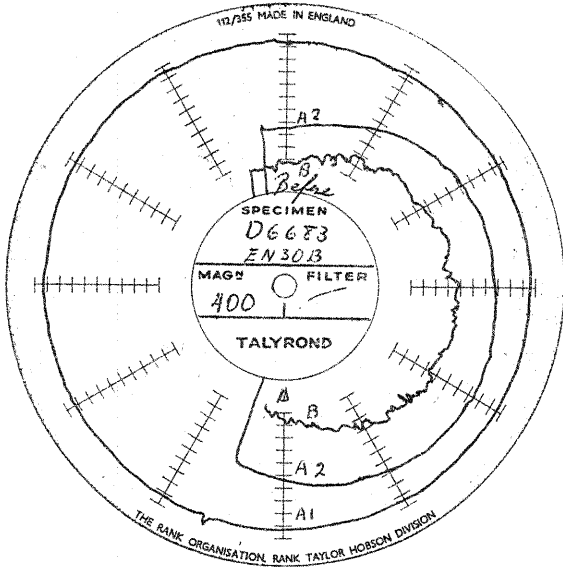

AFTER

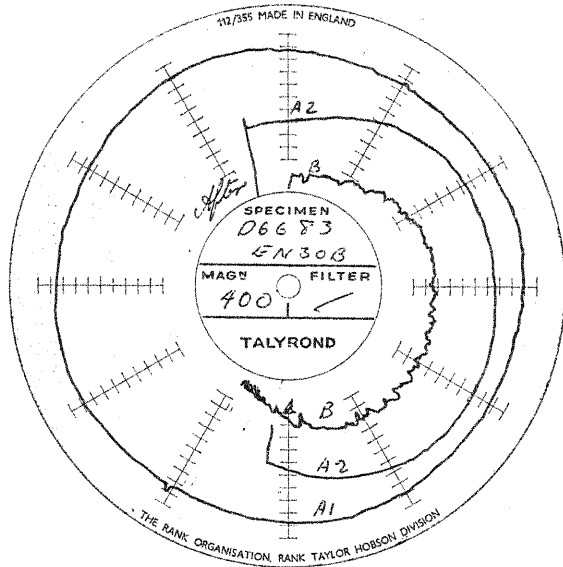

112/355 MADE IN ENGLAND

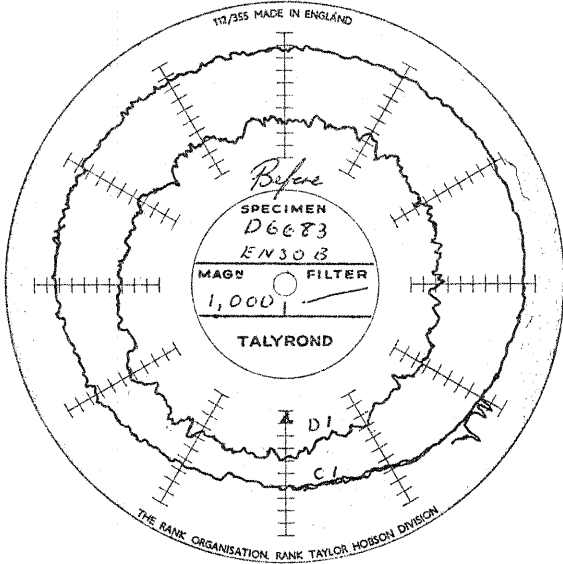

112/355 MADE IN ENGLAND

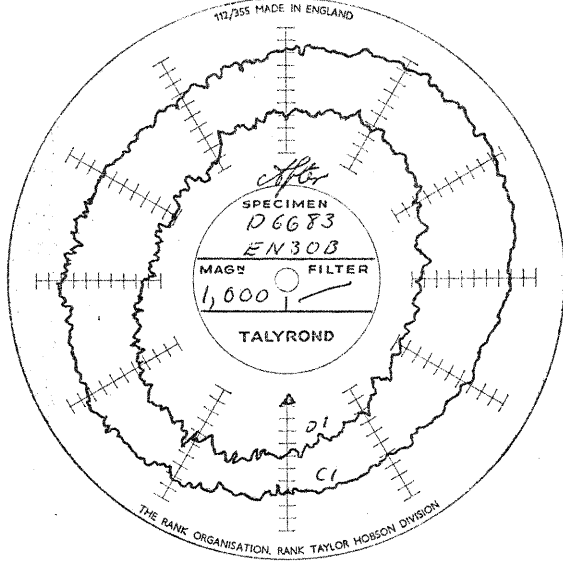

112/355 MADE IN ENGLAND

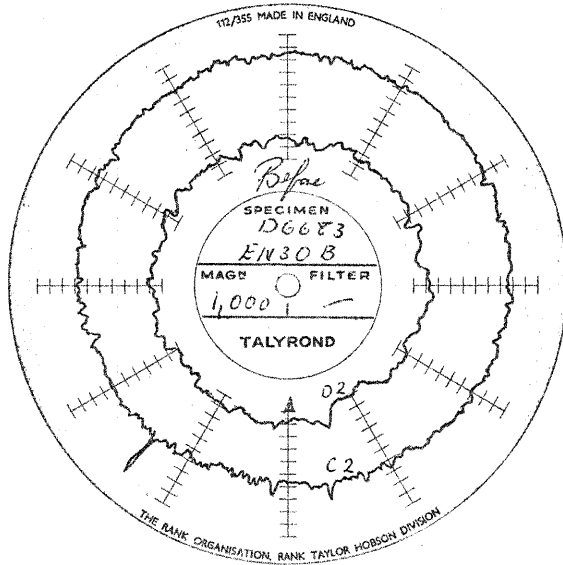

112/355 MADE IN ENGLAND

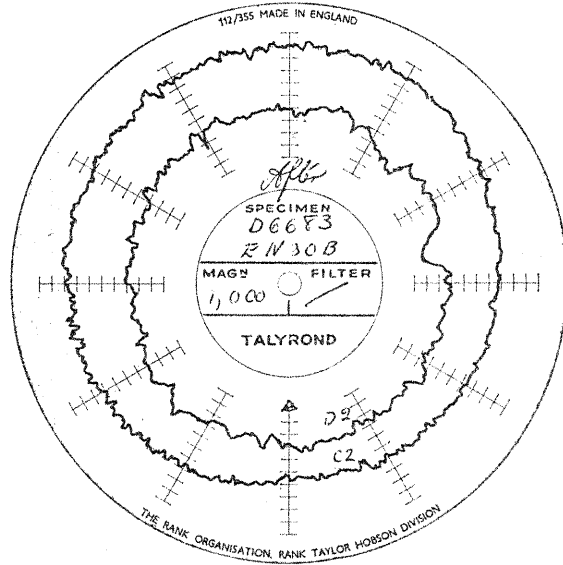

BEFORE

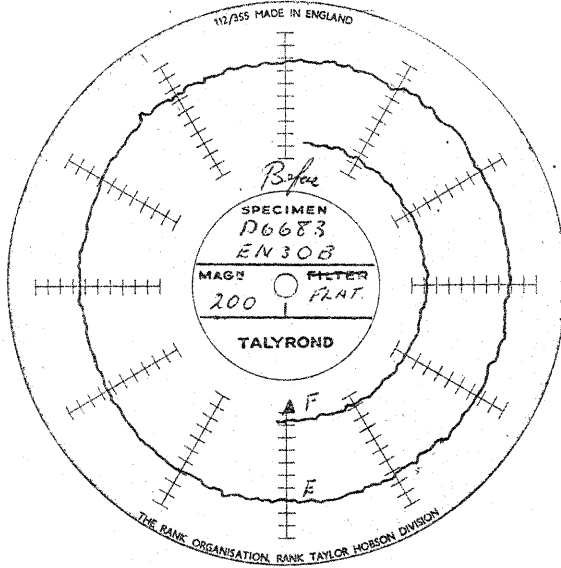

AFTER

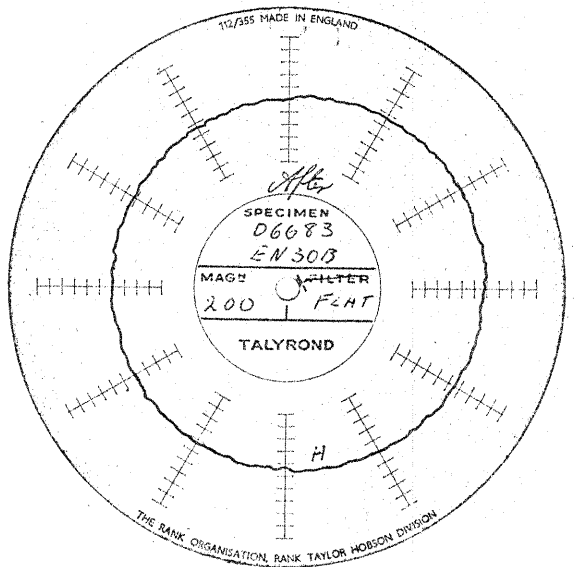
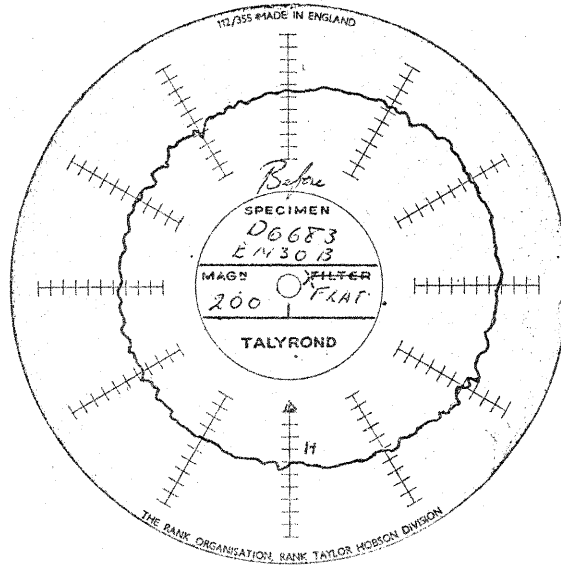
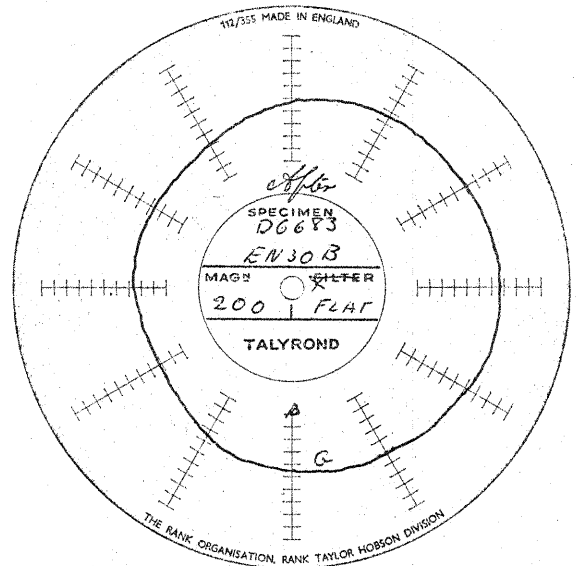
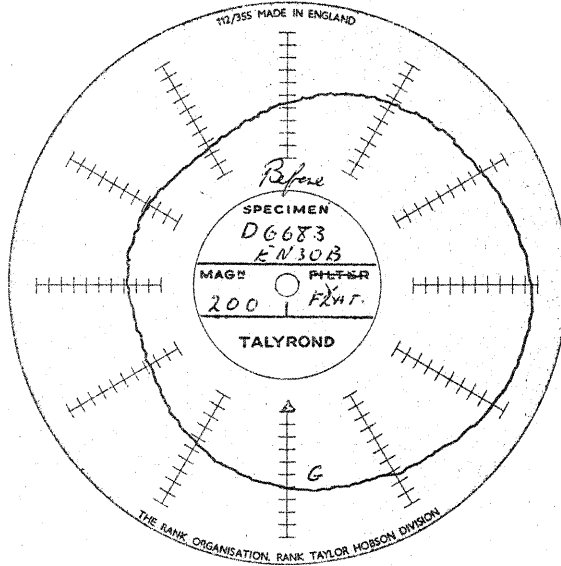
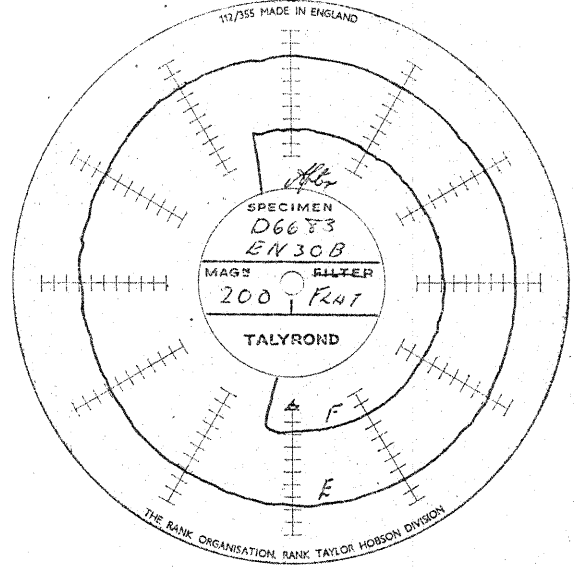

TALYROND RECORDINGS

EN 30 B

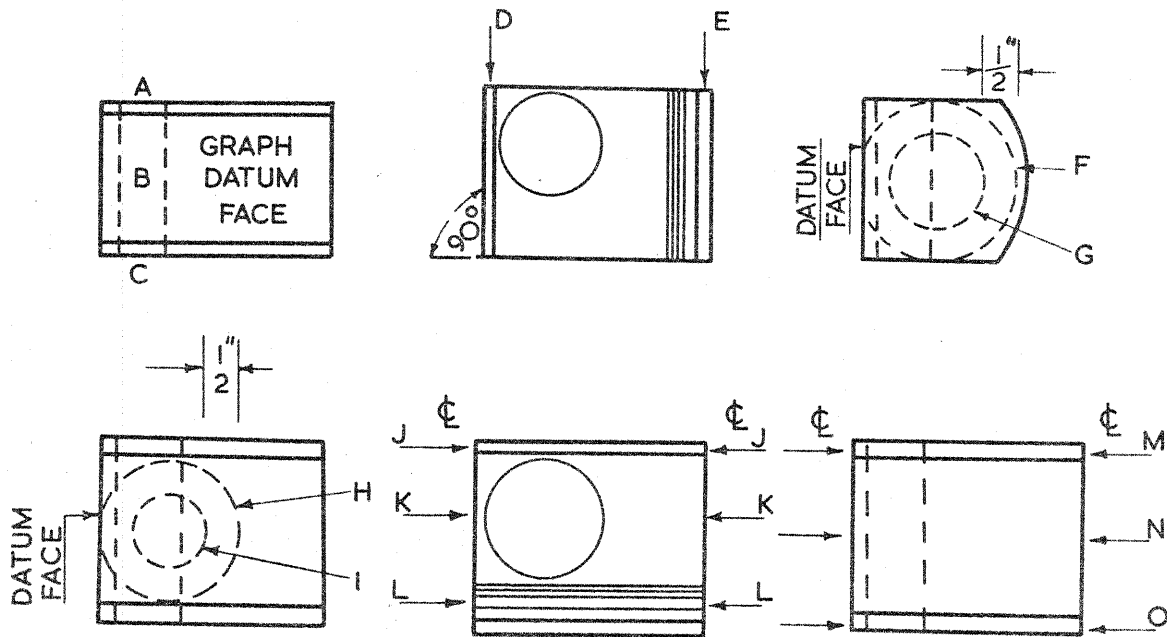

Results from test piece D6684 before and after heat treatment

Nimar 125

E.N. 30B

Position	Size		Shape		Size		Shape	
	Before	After	Before	After	Before	After	Before	After
A	1.0018"	1.0010"	E/c*	E/c*	1.0047"	1.0050"	E/c*	E/c*
B	1.0018"	1.0010"	0.00035"	0.00050"	1.0050"	1.0052"	0.0002"	0.0009"
C	1.0018"	1.0010"	0.00030"	0.00045"	1.0040"	1.0042"	0.0003"	0.0007"
			0.00050"	0.00035"	1.0040"	1.0042"	0.0025"	0.0035"
	<u>Squareness</u>				<u>Squareness</u>			
D	0	0			0	0		
E	-0.0044"	-0.0045"			-0.0068"	-0.0082"		
	<u>Flatness</u>				<u>Flatness</u>			
F	Env.	0.00015"			Env.	0.00040"		
G	0.00010"	0.00010"			0.00010"	0.00040"		
					0.00020"	0.00025"		
	<u>Flatness</u>				<u>Flatness</u>			
H	0.0002"	0.0004"			0.0001"	0.0005"		
I	0.0001"	0.00005"			0.0001"	0.0003"		
	<u>Size</u>				<u>Size</u>			
J	1.6982"	1.6971"			1.7009"	1.7005"		
K	1.6996"	1.6986"			1.7013"	1.7014"		
L	1.7012"	1.7003"			1.7010"	1.7007"		
M	1.6987"	1.6976"			1.7017"	1.7014"		
N	1.6996"	1.6986"			1.7013"	1.7014"		
O	1.7003"	1.6991"			1.6996"	1.6993"		

*Enclosed circle

BEFORE

AFTER

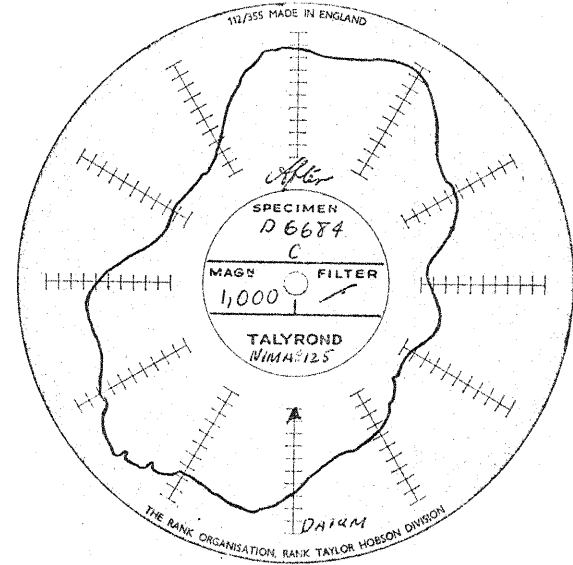
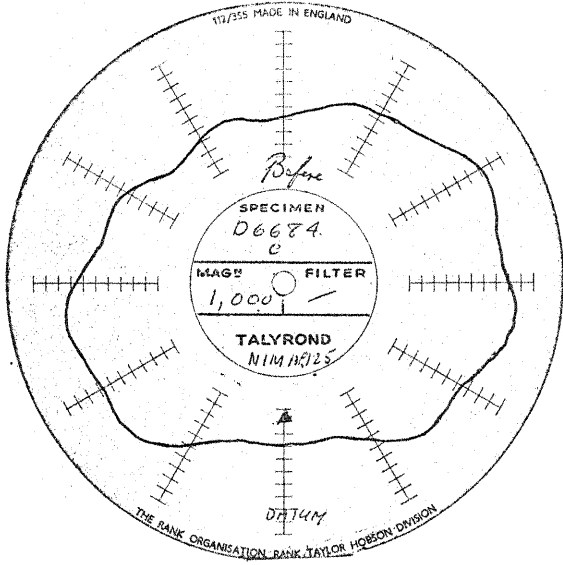
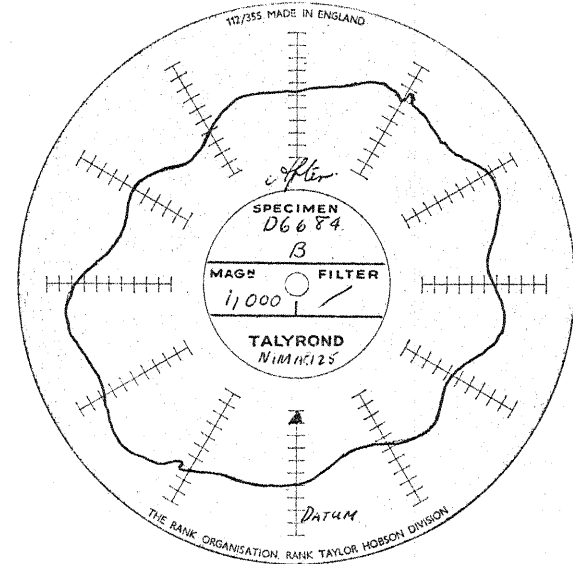
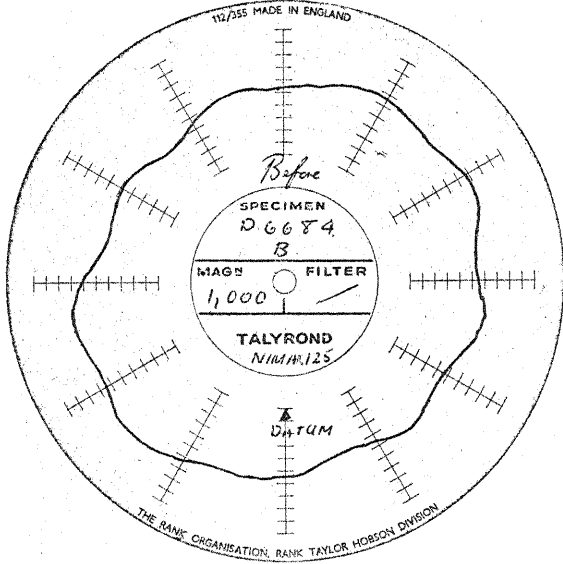
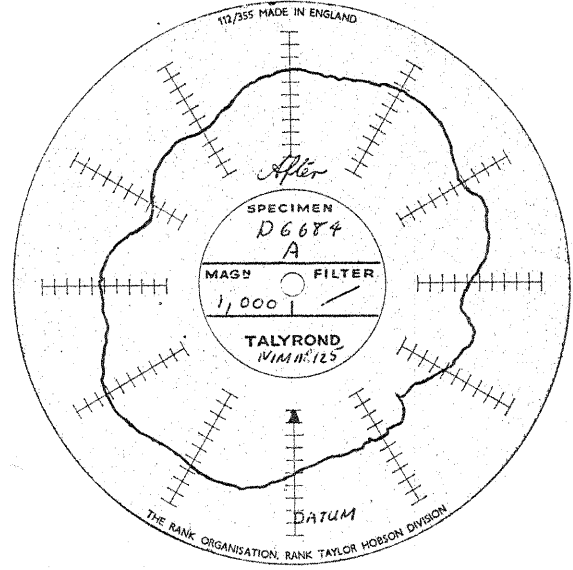
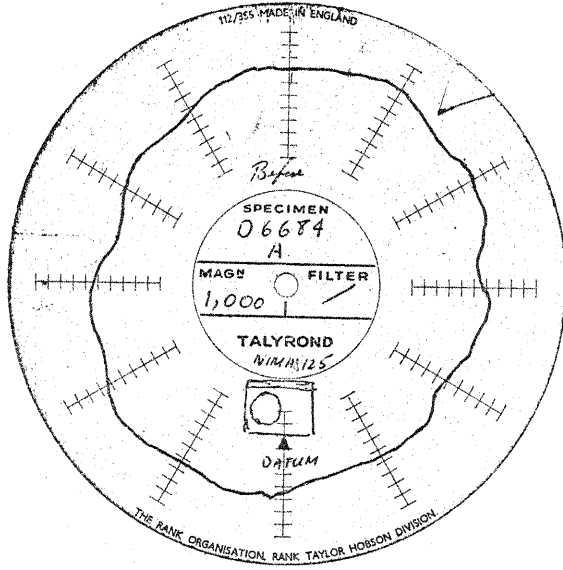

BEFORE

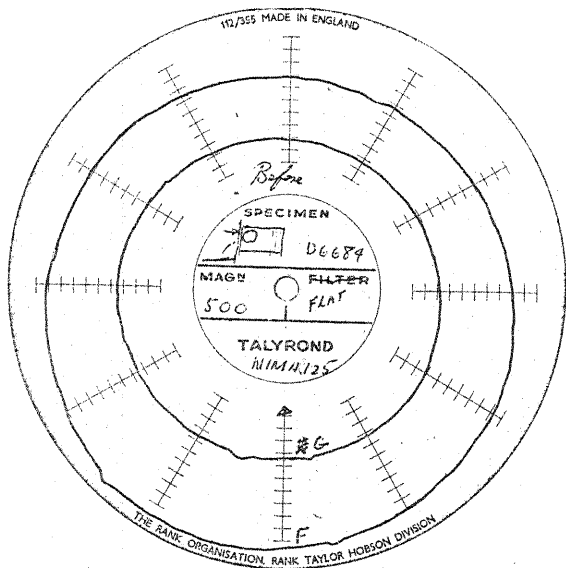

AFTER

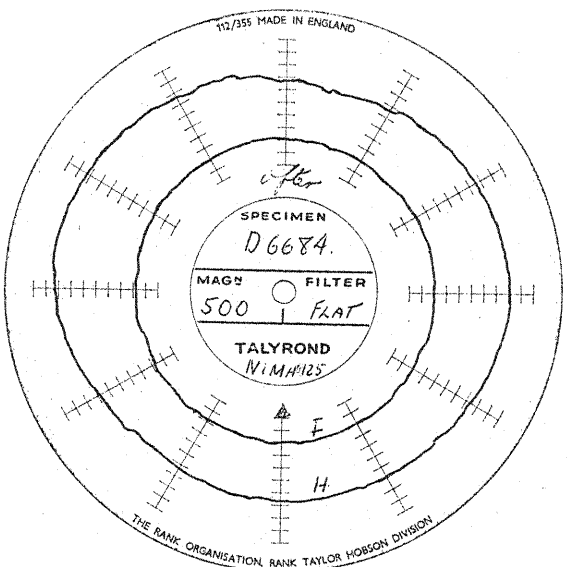
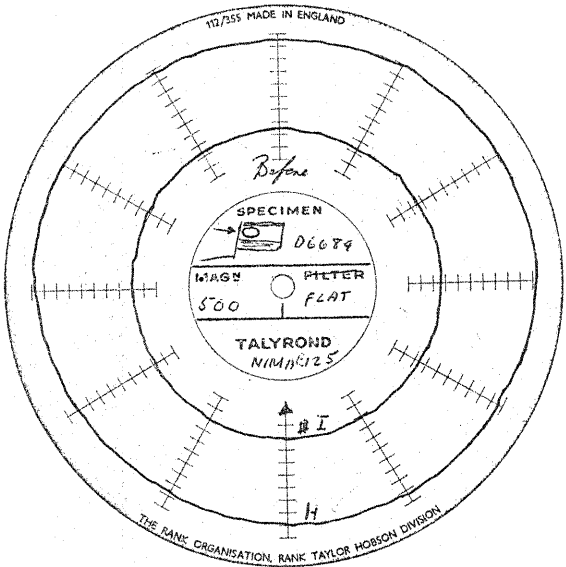
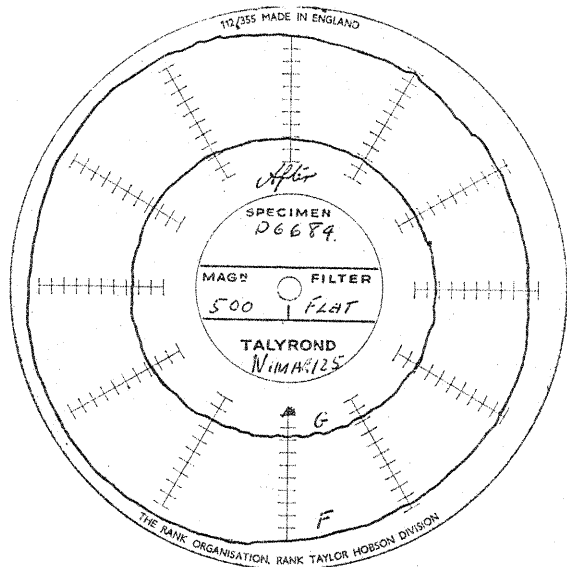

TALYROND RECORDINGS NIMAR 125

BEFORE

AFTER

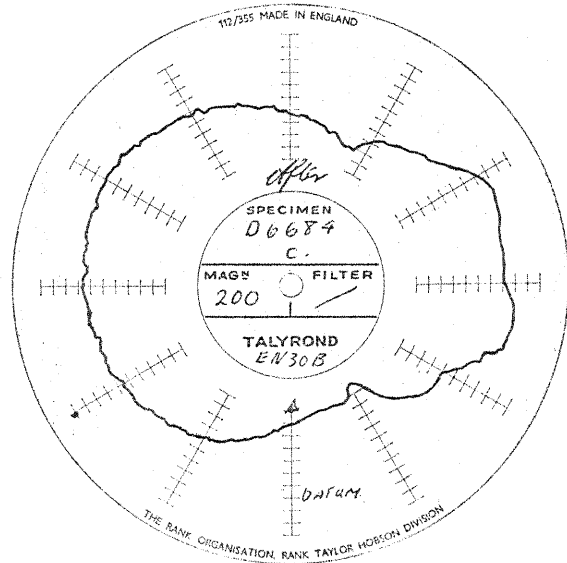
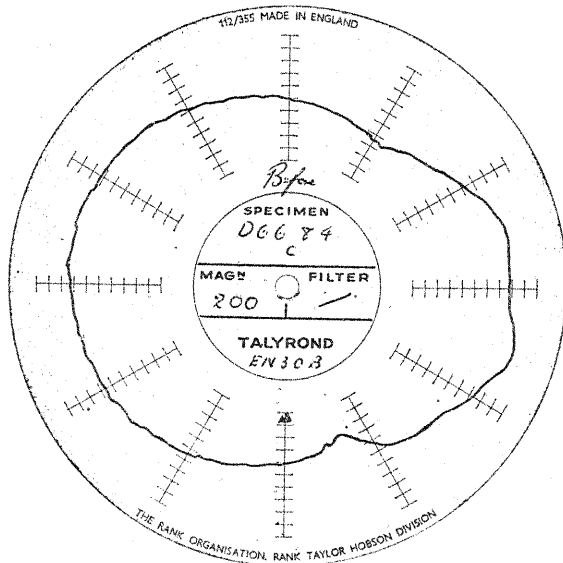
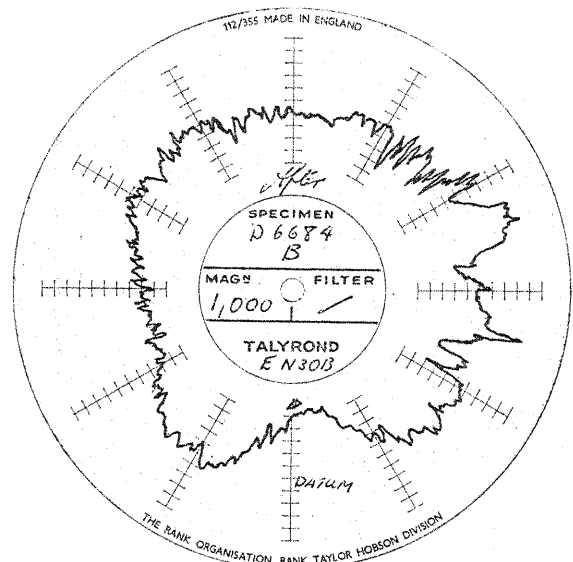
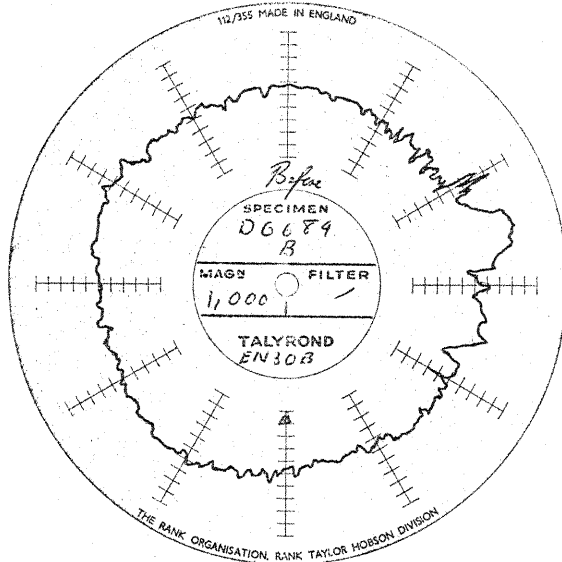
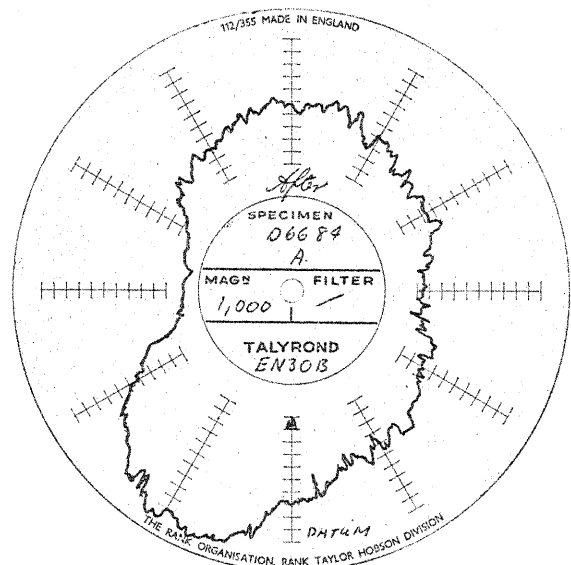
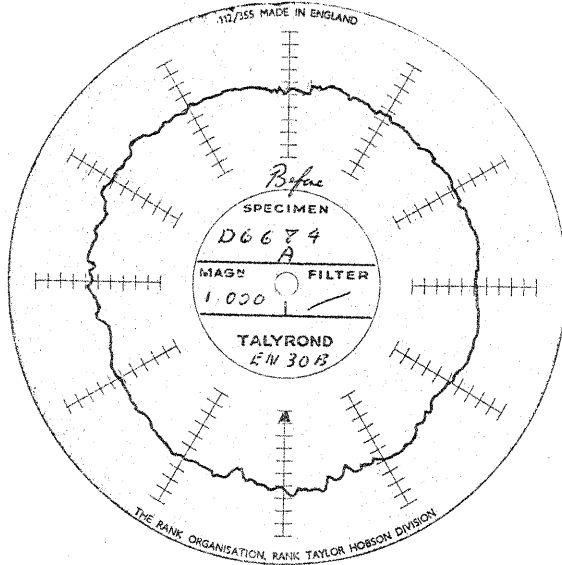

TALYROND RECORDINGS

EN 30 B

BEFORE

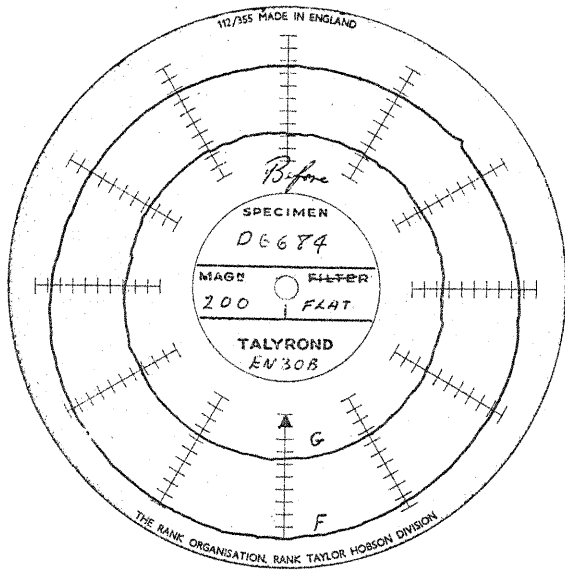

AFTER

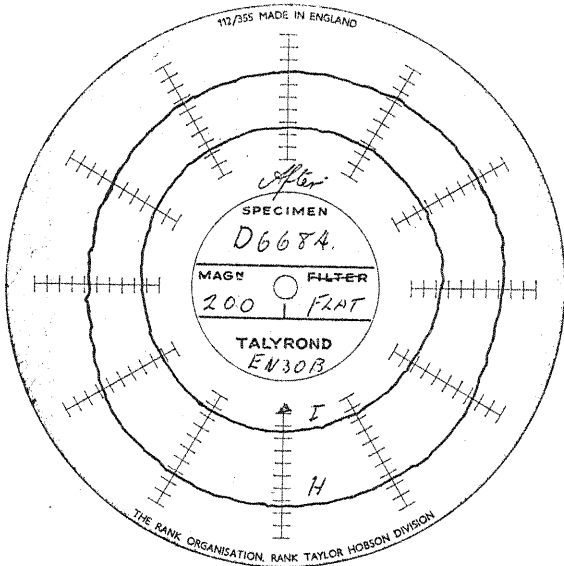
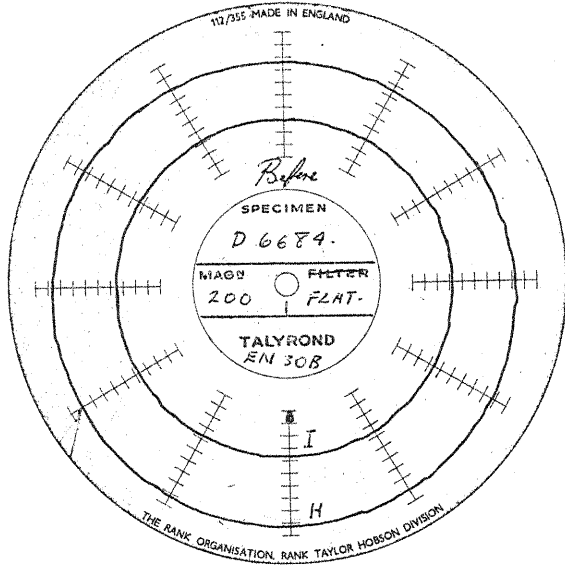
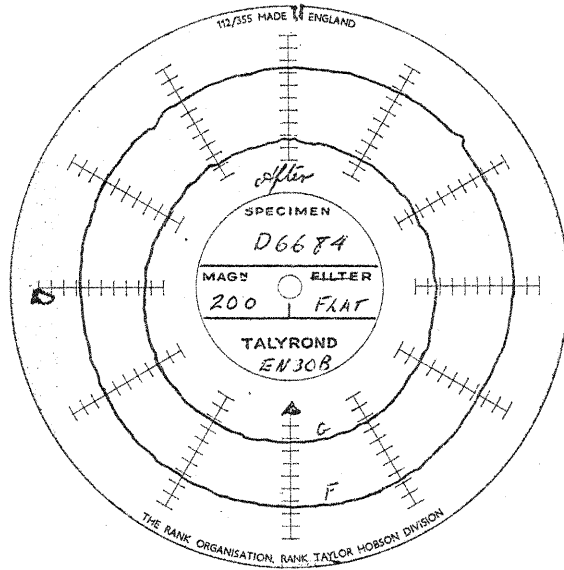

TALYROND RECORDINGS

EN 30 B

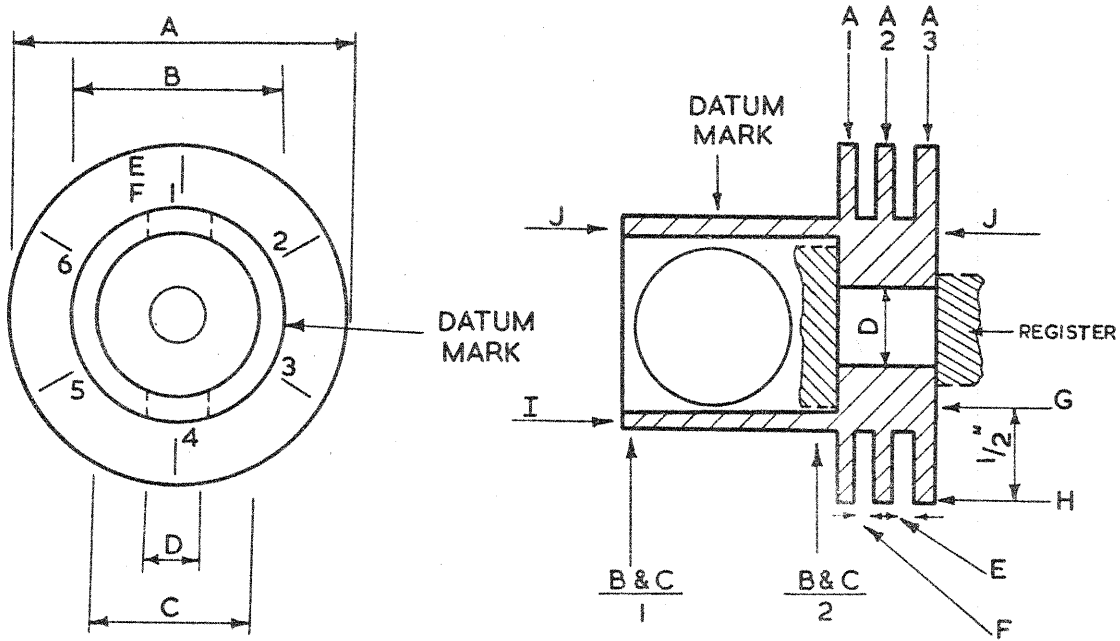

Results from test piece D6685 before and after heat treatment

Nimar 125

E.N. 30B

Position	Size		Shape		Size		Shape	
	Before	After	Before	After	Before	After	Before	After
A 1	Diameter 2.0015"	2.0002"	E/C* 0.0005"	0.0001"	Diameter 2.0144"	2.0140"	E/C* 0.0008"	0.0002"
A 2	2.0015"	2.0003"	0.0005"	0.0001"	2.0144"	2.0142"	0.0001"	0.00015"
A 3	2.0015"	2.0003"	0.0001"	0.0001"	2.0144"	2.0142"	0.0002"	0.00015"
B 1	1.5018"	1.5009"	0.00025"	0.0004"	1.5000"	1.5005"	0.00025"	0.001"
B 2	1.5019"	1.5010"	0.0005"	0.00015"	1.5008"	1.5007"	0.0001"	0.0004"
C 1	1.3496"	1.3486"	0.00025"	0.0003"	1.3518"	1.3520"	0.0007"	0.002"
C 2	1.3486"	1.3477"	0.0001"	0.0002"	1.3520"	1.3520"	0.0001"	0.0004"
D	0.4440"	0.4440"	0.0005"	0.0007"	0.5064"	0.5066"	0.0005"	0.0003"
E 1	0.0812"	0.0815"			0.0758"	0.0758"		
E 2	0.0819"	0.0816"			0.0763"	0.0753"		
E 3	0.0817"	0.0814"			0.0757"	0.0749"		
E 4	0.0817"	0.0816"			0.0767"	0.0754"		
E 5	0.0814"	0.0813"			0.0760"	0.0753"		
E 6	0.0814"	0.0814"			0.0767"	0.0755"		
F 1	0.0837"	0.0836"			0.0762"	0.0753"		
F 2	0.0838"	0.0837"			0.0759"	0.0750"		
F 3	0.0840"	0.0838"			0.0759"	0.0756"		
F 4	0.0838"	0.0836"			0.0757"	0.0757"		
F 5	0.0838"	0.0833"			0.0761"	0.0759"		
F 6	0.0838"	0.0830"			0.0769"	0.0759"		
G			<u>Flatness</u> 0.0002"	0.00015"			<u>Flatness</u> 0.0002"	0.0002"
H			0.0004"	0.0004"			0.0005"	0.0004"
I	<u>Tilt</u> 0.0004"	0.0005"	0.0006"	0.0005"	<u>Tilt</u> 0.0010"	0.0007"	0.0005"	0.0005"
J	<u>At datum</u> 1.3753"	1.3744"			<u>At datum</u> 1.3717"	1.3719"		

*Enclosed circle

BEFORE

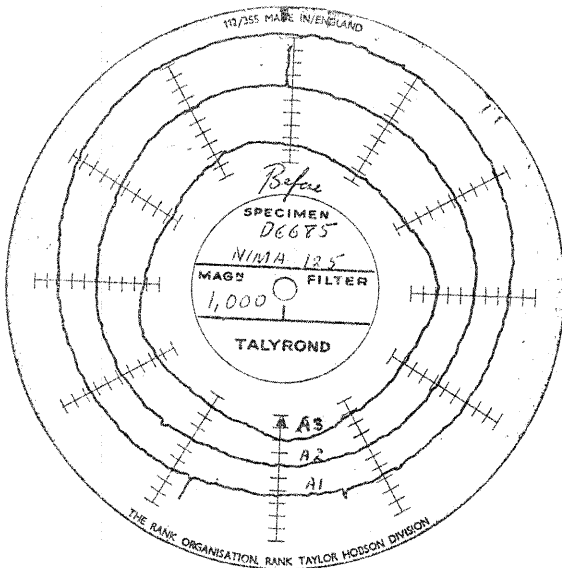

AFTER

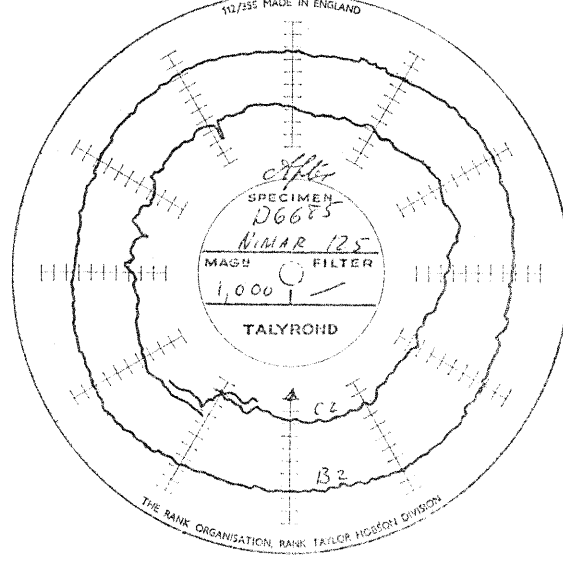
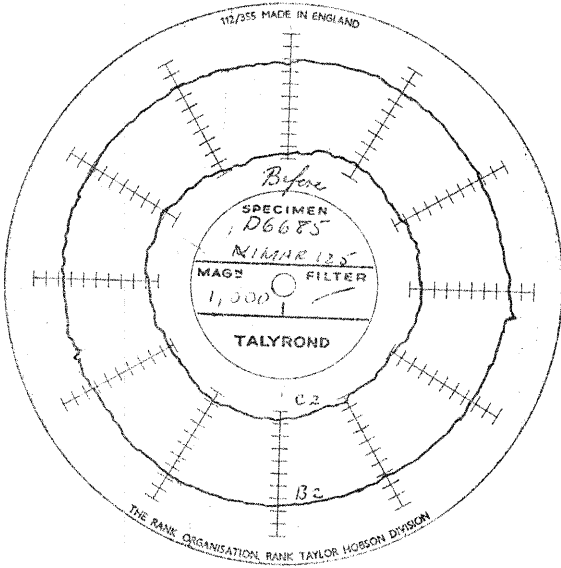
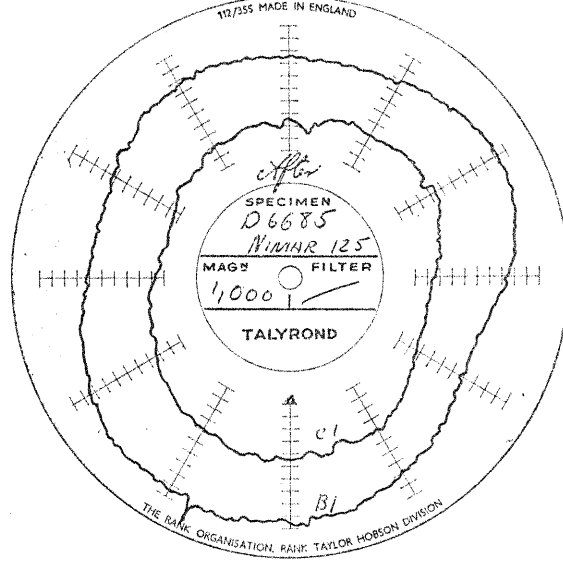
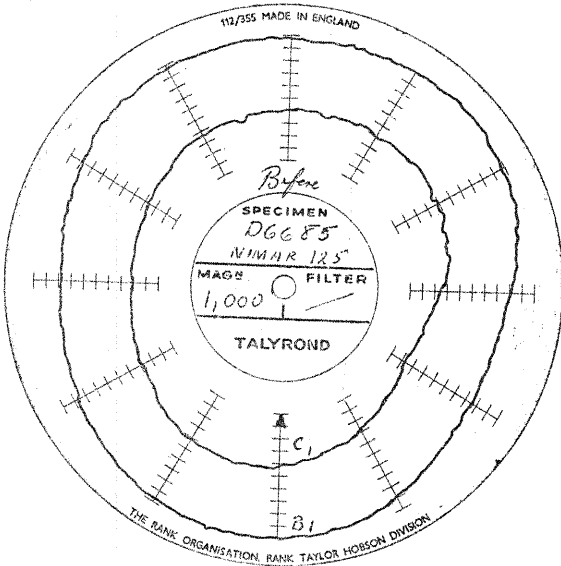
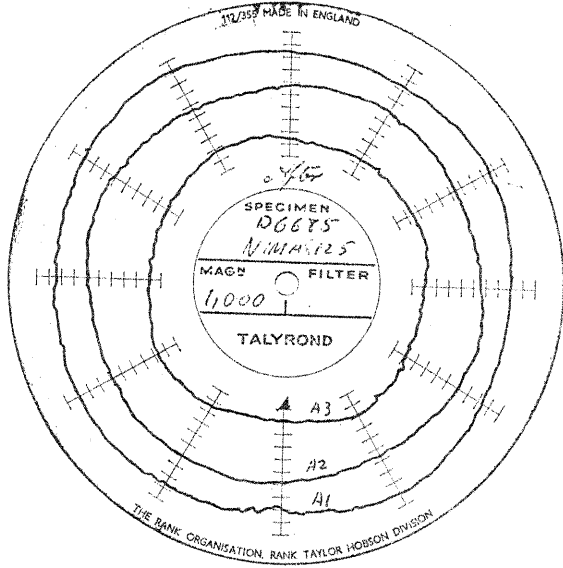

TALYROND RECORDINGS

NIMAR 125

BEFORE

AFTER

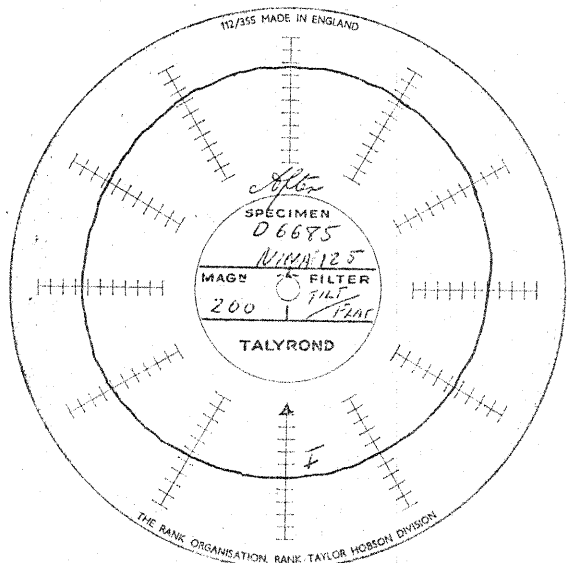
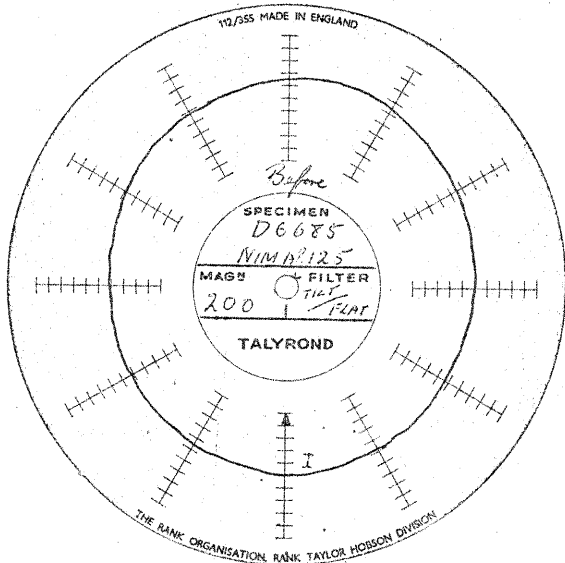
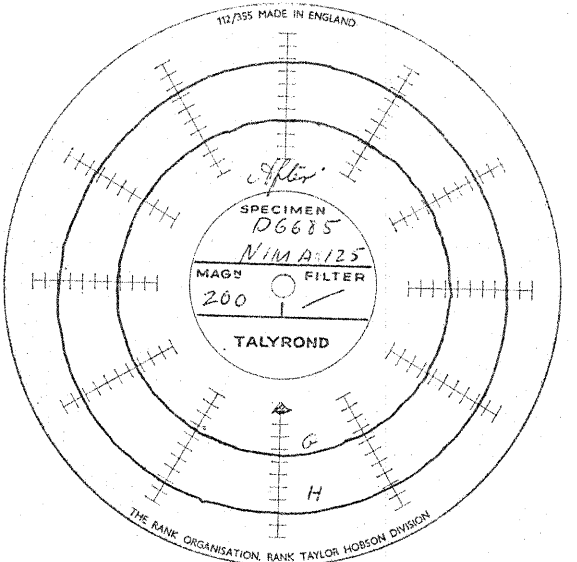
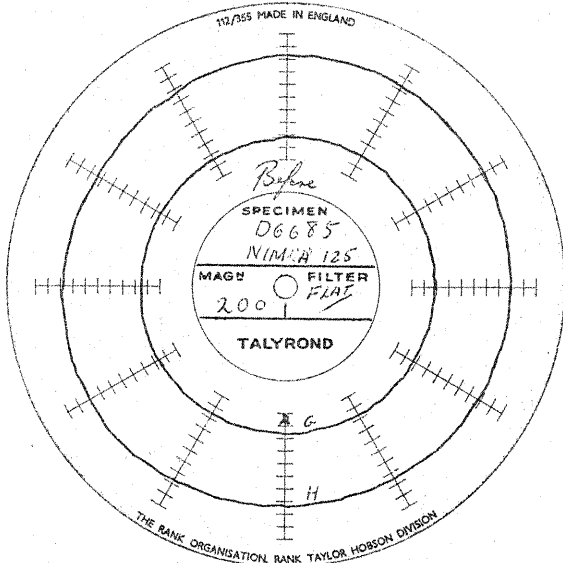
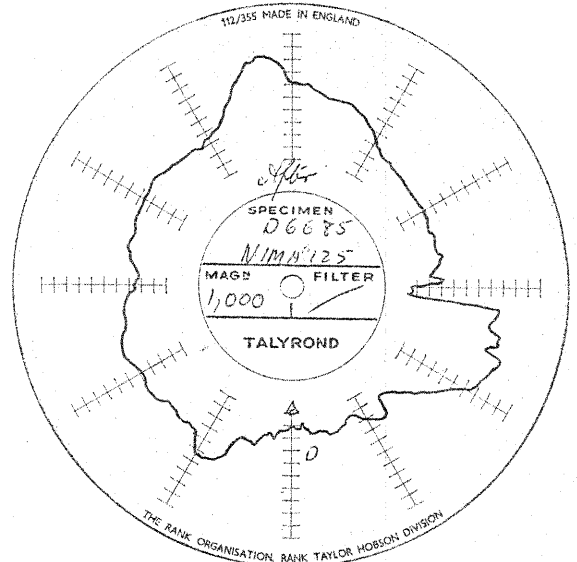
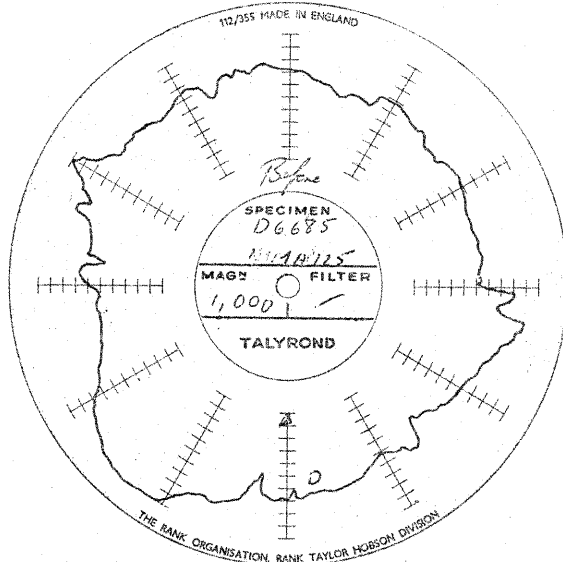

TALYROND RECORDINGS

NIMAR 125

BEFORE

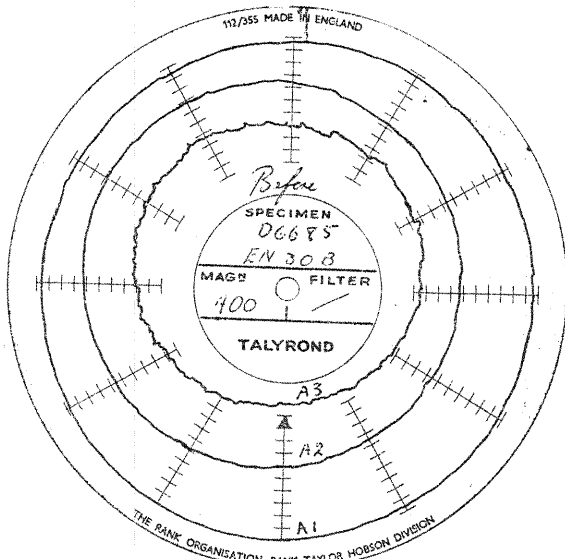

AFTER

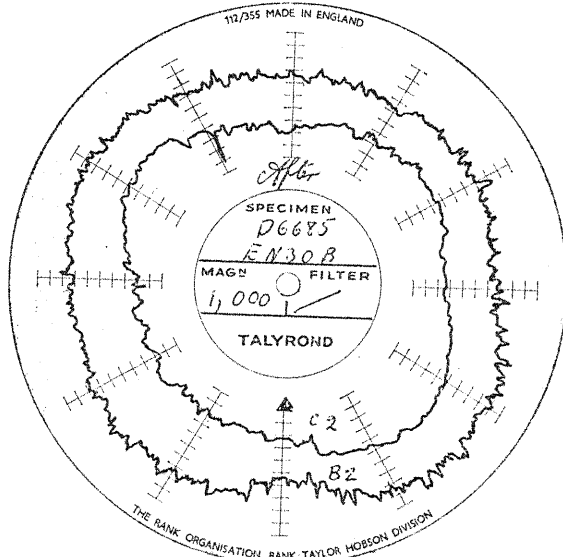
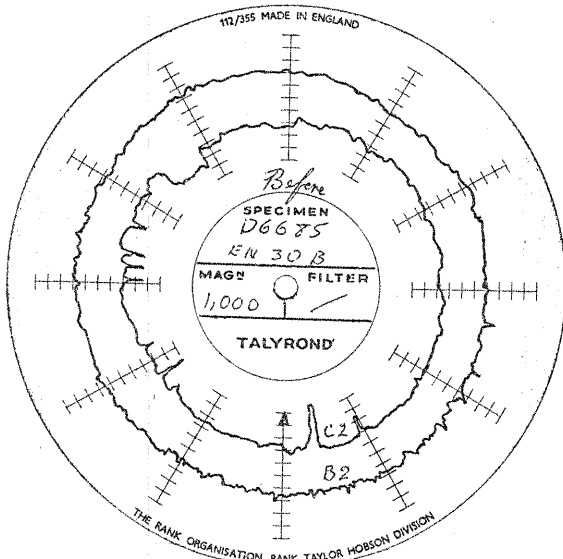
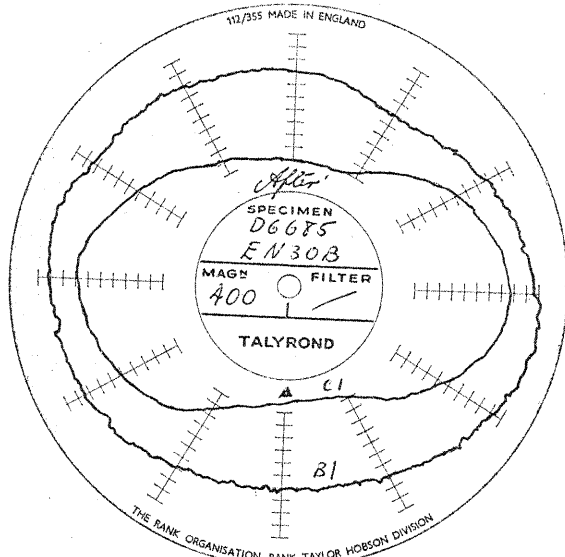
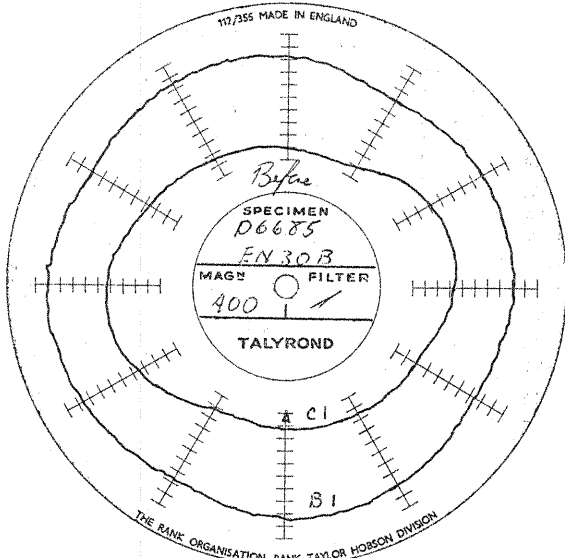
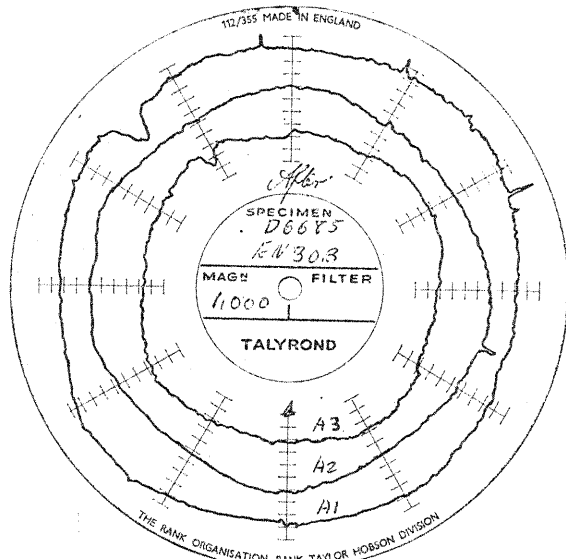

BEFORE

AFTER

