

Review of modern low emissions combustion technologies for aero gas turbine engines (Accepted Manuscript)

Authors:

Yize Liu*, Xiaoxiao Sun*, Vishal Sethi *, Devaiah Nalianda*, Yi-Guang Li *, Lu Wang **

* Propulsion Engineering Centre, Cranfield University, Bedfordshire MK43 0AL, UK

** AEEC Hunan Aviation Power Machinery Research Institute, Zhuzhou, Hunan, China

Correspondence email: yizeliu.liu@cranfield.ac.uk

Abstract

Pollutant emissions from aircraft in the vicinity of airports and at altitude are of great public concern due to their impact on environment and human health. The legislations aimed at limiting aircraft emissions have become more stringent over the past few decades. This has resulted in an urgent need to develop low emissions combustors in order to meet legislative requirements and reduce the impact of civil aviation on the environment.

This article provides a comprehensive review of low emissions combustion technologies for modern aero gas turbines. The review considers current high Technologies Readiness Level (TRL) technologies including Rich-Burn Quick-quench Lean-burn (RQL), Double Annular Combustor (DAC), Twin Annular Premixing Swirler combustors (TAPS), Lean Direct Injection (LDI). It further reviews some of the advanced technologies at lower TRL. These include NASA multi-point LDI, Lean Premixed Prevaporised (LPP), Axially Staged Combustors (ASC) and Variable Geometry Combustors (VGC).

The focus of review is placed on working principles, a review of the key technologies (includes the key technology features, methods of realising the technology, associated technology advantages and design challenges, progress in development), technology application and emissions mitigation potential. The article concludes the technology review by providing a technology evaluation matrix based on a number of combustion performance criteria including altitude relight auto-ignition flashback, combustion stability, combustion efficiency, pressure loss, size and weight, liner life and exit temperature distribution.

Keywords

Low emissions, Technologies, Combustion, Aero engines, Rich Burn, Lean Burn

Nomenclature

ACARE	Advisory Council for Aviation Research and Innovation in Europe
ACS	Axial Controlled Stoichiometry
ASC	Axially Staged Combustor
CAEE	Committee on Aircraft Engine Emissions
CAEP	Committee on Aviation Environmental Protection
CAN	Committee on Aircraft Noise
CMC	Ceramic Matrix Composite
COMAC	Commercial Aircraft Corporation of China
CRZ	Corner Recirculation Zone
DAC	Double Annular Combustor
ECCP	Experimental Clean Combustor Program
EEC	Electronic Engine Control
EI	Emission Index
ERA	Environmentally Responsible Aviation
ETS	Emissions Trading Scheme
FAA	Federal Aviation Administration
FAR	Fuel Air Ratio
FBN	Fuel Bonded Nitrogen
HC	Hydrocarbon
HSR	High Speed Research
ICAO	International Civil Aviation Organisation
IE	Independent Expert
IRA	Intercooled Recuperative
LBO	Lean Blowout
LDI	Lean Direct Injection
LEMCOTEC	Low Emission Core Engine Technology
LPP	Lean Premixed Prevaporised
LT	Long Term
LTO	Landing-takeoff
MFTF	Mixed Flow Turbofan
MLDI	Multipoint Lean Direct Injection
MRA	Multistage Radial/Axial
MT	Mid Term
NEWAC	New Aero Engine Core
NCC	National Combustion Code
OPR	Overall Pressure Ratio
OTDF	Overall Temperature Distribution Factor
PFC	Perfluorocarbon
PM	Particular Matter
PR	Pressure Ratio
P3	Combustor inlet pressure
RQL	Rich-burn Quick-quench Lean-burn

RTDF	Radial Temperature Distribution Factor
SAC	Single Annular Combustor
SD	Stepped Dome
SFC	Specific Fuel Consumption
SLS	Sea Level Static
SN	Smoke Number
SV-LDI	Swirl-Venturi Lean Direct Injection
TAPS	Twin Annular Premixing Swirler
TALON	Technology for Advanced Low NOx
TCLA	Turbine Cooling and Leakage Air
TET	Turbine Entry Temperature
TRL	Technologies Readiness Level
T3	Combustor inlet temperature
UHC	Unburned Hydrocarbons
UV	Ultraviolet
VGC	Variable Geometry Combustor

1. Introduction

The main pollutants emitted by aircraft are in the form of NO_x (comprising NO and NO₂), Unburned Hydrocarbons UHC, CO, Sulphur Oxides (SO_x) and Particulate matter PM that contains mainly smoke/soot. The effect of emissions on human health is summarised in [Table 1](#) [152]. Aviation emissions generally have two main impacts: one on the local air quality, specifically in the vicinity of airports; and the second on global climate. In the vicinity of airports, the pollutant emission of primary concern is NO_x (NO and NO₂), is produced by aircraft, ground services equipment and access road traffic. Aircraft NO_x emissions contribute between 70% and 80% of total airport NO_x emissions. A comprehensive global prediction of future emission trends that affect local air quality has been conducted by the Committee on Aviation Environmental Protection (CAEP) [152]. As shown in [Figure 1](#), results indicate that NO_x emissions below 3000 feet will increase from 0.25 million metric tonnes (Mt) in 2006, as the baseline, to between 0.52Mt and 0.72Mt in 2036. NO_x emitted by aircraft at low altitude contributes to the formation of the ozone that leads to human health issues and local air quality, whereas at high altitude NO_x depletes ozone and results in the increase in the ground level Ultraviolet (UV) radiation.

The early combustor technology: ‘conventional’ combustors have been evolved over seven decades. Combustion is initiated in the primary zone with a fuel-air ratio close to stoichiometric value that leads to maximum heat release. Air that is initially bypassed from the combustor dome entry is then gradually admitted into the primary, secondary and tertiary zones to enable stable and complete combustion process and control of exit temperature distribution. The schematic drawing is shown in [Figure 52](#). Older conventional combustors contain longer liners (with length to dome ratio is greater than 2.0) hence resulting in longer residence time to assure high combustion efficiency. Pressure atomisers with diffusion based combustion were also extensively employed as it was advantageous in having wider stability limits, strong flashback resistance and improved engine operability. On the other hand, the less uniform fuel-air mixing resulted in higher local temperature and rich stoichiometry, leading to large NO_x production and soot formation. The general emissions levels for conventional combustors (thrust levels over 26.7kN) are greater than CAEP/1 or ICAO 1986 standard, as summarised in [Table 2](#).

Over the past 40-50 years, the aviation industry has been capable of reducing fuel consumption by 70% while also limiting noise and reducing gaseous CO and HC emissions by approximately 50 and 90%, respectively [15]. This is mainly due to technology improvement in materials and cooling that enable engines to operate at higher Overall Pressure Ratios OPRs and Turbine Entry Temperatures (TET) to increase thermal efficiency which in turn reduces the engine specific fuel consumption (SFC) for economic benefit. This leads to high combustor inlet temperature and pressure. These wide

environmental benefits (e.g. CO₂ reduction) achieved through higher OPR and TET therefore also led to an increase in NO_x emission. Until 1970s, when larger OPR engines were developed less attention was paid to NO_x emissions until serious concerns were raised by the general public on the effects of NO_x on human health and climate.

These concerns gave rise to the first official aircraft emissions regulations, which were imposed in the 1960s and 1970s. Later the International Civil Aeronautics Organisation (ICAO) adopted a standard that applied to all in-production engines in 1986, namely the CAEP/1 or ICAO 1986 standard. ICAO has updated and published more stringent standards for NO_x emissions during subsequent ICAO meetings. These regulations drive the development of low emissions technology and the consequence of which is that several emission reduction targets were implemented worldwide to fulfil the future legislative requirements.

The development of low emission combustor concepts for aero engines has been underway since the mid-1970s based on the experience gained from single annular conventional combustors (sometimes referred to as PreLEC, such as in reference [10]). The improvements of fuel injection devices along with combustion and dilution flow optimisation led to the state-of-the-art (at the time) *Low-Emissions Combustor (LEC) technology* [11] [12] [13] [14], termed as ‘old single annular’ that is distinct from old conventional combustor, in Figure 2. Figure 2 also summarises the emissions level as a function of engine OPRs for different CAEP standards. Lean dome combustion was later followed by the creation of *Double Annular Combustor (DAC)* being considered as an alternative to LEC. The DAC technology enabled achieving up to 60% reduction from the first International Civil Aeronautics Organisation (ICAO) standard as well as a 50% reduction in cruise NO_x [15]. In order to further reduce emissions, lean partially premixed combustion was introduced. This was achieved through the inception of *Twin Annular Premixing Swirler TAPS* combustors. This technology was developed later as the next generation for further emission reduction and achieved a remarkable reduction of 60% against CAEP/6. In the meantime, some advanced rich dome combustion technologies were developed based on experience gained from LEC technology. Typical examples include the Pratt & Whitney P&W TALON series and Rolls Royce Phase 5. Both TAPS and advanced rich burn technologies feature a single annular version, shown as ‘current single annular’ in Figure 2.

Future aero gas turbines will develop technologies to improve the fuel efficiency by increasing the engine Overall Pressure Ratios OPRs (from 25 to 60 –75) when compared with generation of previous engines. The higher OPRs have made it challenging to contain NO_x level without changing the fuel injection concept. Therefore, some new concepts such as NASA multi-point injection are currently under development. Future high OPR engines

pose a design challenge for premixed combustion due to risks of auto-ignition and flashback. These risks can be mitigated by Lean Direction Injection such as Rolls Royce LDI that is under development and approaching a Technology Readiness Level (TRL) of 7. The emissions controlling mechanisms are described in section 1.3.

Publications usually pay attention to certain low emissions technology with a focus placed on specific aspects of technology development. The motivation for writing this article is to conduct a comprehensive review of low emissions combustion technologies. The focus is on highlighting their working principles, and key technology features, approaches of realising the technology, associated technology advantages and design challenges, progress in technology development and applications and emissions level. The article concludes the technology review by providing a technology evaluation matrix based on a number of combustion performance aspects including altitude relight auto-ignition flashback, combustion stability, combustion efficiency, pressure loss, size and weight, liner life and exit temperature distribution.

1.1 Legislative regulations and standards status

The emissions regulations for aircraft are established by the International Civil Aviation Organisation (ICAO) adopting a standard landing take-off (LTO) cycle intended to simulate the aircraft operation below 3000 feet altitude. For subsonic civil aero engines, it is composed of four operating modes (idle, take-off, climb-out and approach) measured at sea level, static and standard day conditions (Figure 3). For supersonic aircraft engines, descent is added into the cycle. Emissions are measured as a part of the airworthiness certification process under the supervision of a national airworthiness authority. (e.g. European Aviation Safety Agency, EASA or the U.S Federal Aviation Administration, FAA). During the test, the fuel flow, gaseous emissions (NO_x, UHC, CO) and smoke are measured using sampling, gas analysis and a typical smoke measurement method specified in ICAO Annex 16, Volume II [1]. The mass of gaseous emissions for each species (D_p) is determined then by summing all modes in the LTO cycle. The standards for gaseous emissions (NO_x, UHC and CO) are based on calculated D_p for each species divided by the maximum sea level static rated thrust (F_{oo}) to take account of engine size. The ICAO Emissions Standards set maximum limits on D_p / F_{oo} of each gaseous emission. The standards apply to the subsonic aircraft engines whose F_{oo} is above 26.7kN (6000 Ib) and therefore do not regulate smaller subsonic engines as they make a minor contribution to the total emissions. Smoke is measured by locating a filter downstream of the engine through which the exhaust passes, and it is measured in terms of Smoke Number (SN) which is a function of rated thrust (F_{oo}).

The first ICAO standard was regulated by the ICAO Committee on Aviation Engine Emissions, (CAEE) in 1981. Later, the CAEE was combined with Committee on Aircraft Noise (CAN) and the Committee on Aviation Environmental Protection (CAEP) was established in 1983. In order to reduce the impact of aircraft emissions on the environment, CAEP meets every three years to continually formulate and update the emission standards [2]. The standards for smoke, CO and UHC remain unchanged in subsequent review. As NOx has been considered as a primary issue, ICAO adopted a more stringent standard for NOx emissions at the 2nd, 4th, 6th and 8th meetings of CAEP. (i.e. CAEP/2 1993, CAEP/4 1999, CAEP/6 2005, CAEP/8 2011), as indicated in Figure 3. The NOx emission currently remains at the CAEP/8 standard.

In recent years, the focus of CAEP has been expanded to develop global standards for CO₂ emission and non-volatile particulate matter standard (nvPM). Consequently, during the CAEP/10 meeting in 2016, recommendations have been made for the two complementary new standards for the emissions. The CO₂ standard will apply to subsonic aircraft of new type design starting in 2020, and to those in production in 2023 [4]. Additionally, attention is also been accorded to address the impact of emissions at high altitude (i.e. NOx at climb and cruise) [3].

1.2 Main Pollutants Generation Mechanism

1.2.1 Nitrogen Oxides

Nitrogen oxides are a primary air pollutant which is linked to tropospheric ozone (O₃): (i.e. ozone formation in the troposphere) and has an adverse impact on human health. This emission is known to cause respiratory illness, impaired vision, headaches, hearing disorder and allergies [5]. The formation mechanisms are:

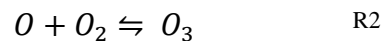
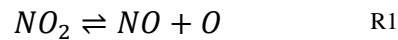

Nitrogen oxides (NO_x) are also linked to ozone layer depletion in the Stratosphere whose relevant formations are:

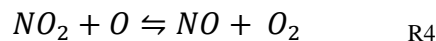
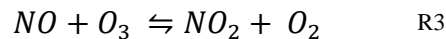

The NO produced at the end of reaction will in turn further deplete the ozone layer and chain reaction takes place. The ozone layer depletion in the Stratosphere will increase the

ground level UV radiation and cause skin cancer and eye diseases. NO_x is also linked to photochemical smog, acid rain and global warming [6].

The thermal NO is one of the major sources of NO_x produced in practical gas turbine combustors. It is produced in the post flame region where the flame temperature is above 1800 K. The chemical reaction is endothermic (i.e. atomic dissociation occurs when diatomic oxygen (O_2) gains enough energy through heat absorption to break into two oxygen atoms). The set of reactions is known as the Zeldovich mechanism and details are shown below:

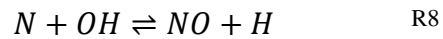
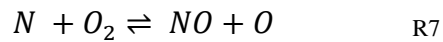
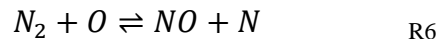

Nitrogen Oxide (NO) is produced when nitrogen reacts with oxygen atoms via R5 at high temperatures. A chain reaction is then initiated as the nitrogen atom which is produced in R5 can react with molecular oxygen (O_2) (shown in R7) and OH radical in R8 to form NO with O and H atoms. The concentration of atomic oxygen in the flame front is largely an exponential function of temperature, and NO formation via the Zeldovich mechanism has a similar relationship with flame temperature. Therefore, the thermal NO is increased exponentially with flame temperature for both premixed and diffusion systems.

Prompt NO formation is an attribute of hydrocarbon flames where hydrocarbon radicals such as CH react with molecular N_2 [7].

Formation of NO from chemically bound nitrogen is complex due to the varying structure of the nitrogen bonding to the parent molecule. According to Glarborg *et al.* [8] most of the fuel bound nitrogen is converted to HCN and NH_3 to react with combustion radical to form NO.

1.2.2 Carbon Monoxide

CO is produced when an engine is operating fuel rich due to lack of sufficient oxygen to complete the reaction to CO_2 . Also, it implies the inadequate combustion efficiency in gas turbines. However, high level concentration of CO is formed at low power condition where the combustor inlet temperature, pressure and equivalence ratio are relatively low. These lead to a relatively low reaction rate of converting CO to CO_2 . When the fuel air mixture is stoichiometric and flame temperature peaks above 1800K, the dissociation of CO_2 occurs. Therefore a significant quantity of CO is also produced. CO, in terms of its effects on human health, reduces the capacity of the blood to absorb oxygen and, in high concentrations, can cause asphyxiation and even death [9].

1.2.3 Unburned Hydrocarbons

Unburned hydrocarbons UHC are in form of fuel drops or the products of thermal degradation of parent fuel into species of lower molecular weight [9]. It indicates the wastage of fuels, hence increases the engine operating cost. The formation of UHC mainly stems from unsatisfactory quality of fuel atomisation, inadequate reaction rate, local quenching, incomplete combustion and combination of any of these. The chemical kinetics of UHC is more complex than CO. Nevertheless, the main influencing factors for UHC and CO productions are similar.

1.2.4 Sulphur Oxides

Sulphur oxides (SO_x) are usually formed when the fuel containing sulphur compounds react with oxygen during the combustion. It is toxic and corrosive which leads to reduction in turbine blade life, and formation of sulfuric acid in the atmosphere. The sulphur contained in the fuel is oxidised to SO_2 at high temperature in aircraft engine combustion. The level of sulphur contained in the fuel is constrained by fuel specification for Jet A and JetA-1 to be less than 3,000 ppm (parts per million by mass) or 0.3 weight percent [132] [5]. Therefore, emissions of sulphur oxides in the combustor are limited by reducing or eliminating the sulphur content from the fuel. In fact, most fuels fall below this specification, and typical fuel sulphur levels for aviation jet fuel are between 200 and 1200 ppm. The small quantity of sulphur contained in jet fuel is believed to be beneficial in preventing the erosion of the fuel delivery system because of its lubricity [7].

1.2.5 Soot/Smoke

Soot/smoke is produced in the fuel-rich regions of the flames, where burned gases move toward the fuel injector where local rich fuel pockets are enveloped by deficient oxygen gases at high temperature [5]. Also, it can be produced anywhere in the combustor where mixing is inadequate [9]. Most soot is formed in the primary zone and is consumed downstream at high temperature; namely the primary zone governs formation of the soot and the high temperature downstream regions (e.g. intermediate and dilution) determine its consumption. The main influencing factors for soot formation are pressure, equivalence ratio, and fuel type and atomisation quality. Studies indicate that soot formation increases with increase in pressure. To elaborate, when the pressure is increased, the limit of flammability is extended such that soot produced earlier that is too rich to burn at lower pressures can now burn. Also with an increase in pressure, the chemical reaction rate is accelerated with fuels burned in the fuel rich region and hence soot is formed.

1.3 Emission Controlling Mechanisms

Amongst all factors influencing the pollutant emissions from gas turbine combustors, the most important is the flame temperature in the combustor primary zone. Figure 4 indicates

the emissions as function of flame temperatures: below 1670K significant CO is produced whereas when it is above 1900K, excessive amount of NO_x is produced. Between 1670K and 1900K, there is a narrow band where CO and NO_x emissions are relatively low (i.e. 25ppmv for CO and 15ppmv for NO_x). As previously stated, modern engines have higher OPR and TET in order to increase the thermal efficiency and reduce engine specific fuel consumption SFC; therefore, the 'low emissions band' may shift rightward to the plot. The basic strategy for limiting the pollutant emissions is therefore controlling the temperature of the primary combustion zone within this narrow band over the entire power ranges of the engine.

The NO_x reduction is realised by moving the fuel air ratio away from the stoichiometric value since maximum heat release hence highest flame temperature occurs close to that value. Therefore, combustion can be initiated with less air (rich burn) or excessive air (lean burn). In the latter case, a large fraction of the air flows through the combustion dome and is mixed with fuel so that a lower flame temperature can be achieved compared to rich burn. However, this poses a stability challenge at low power where the fuel-air ratio may approach the lean extinction limit.

Fuel staging is employed such that part of the fuel injectors is turned off at low power. In this manner, the local equivalence ratio is maintained close to the stoichiometric value at the operating fuel injection zones so as to maintain high combustion efficiency and stability. **Figure 5** shows the NO_x distribution within the LTO cycle for rich and lean burn. Increased reduction in high power NO_x can be achieved by lean burn since the flame temperature gradient is higher for the lean side than the rich side. However, the low power emissions for both mechanisms show similar characteristics. This is primarily due to the increase in flame temperature via fuel staging, as previously described.

The bulk equivalence ratio either for rich burn or lean burn in the primary zone represents only a rough guide to emission reductions. The actual values are heavily dependent on the effective fuel-air mixing. Unsatisfactory mixing quality would produce a large variation in local fuel air distribution; the rich pocket yielding a local hot 'spot' which would produce higher NO_x and smoke emissions. Therefore, good fuel atomisation and fuel air mixing are vital for low emission reduction.

The flow residence time within the combustor zone is also a crucial factor that needs to be controlled. Sufficient residence time should be allowed for complete combustion to ensure that CO and UHC are reduced; on the other hand the residence time should not be long for excessive NO_x production.

1.4 Worldwide Emissions Reduction Targets

1.4.1 ICAO NO_x Mid-term and Long-term Goals

The NO_x goals have been highlighted by the CAEP Independent Expert (IE) group. It issued a report (ICAO Doc 9887) which stated that the LTO NO_x reduction goals for medium term and long term are: 45% reduction of CAEP/6 for 2016 and 60% reduction of CAEP/6 for 2026, respectively. The two goals are taking CAEP/6 as the reference point, which applies for the new engines manufactured since the year 2008[16].

1.4.2 ACARE Vision 2020 and Flightpath 2050

ACARE is the Advisory Council for Aviation Research and Innovation, led by the European Commission. It set out the two challenging goals for emissions reduction to be achieved by the time frame 2020 and 2050 relative to year 2000 technology: Vision 2020 and Flightpath 2050. LTO NO_x emissions goals are: 80% reduction that is equivalent to -60% CAEP/6 (Vision 2020) and 90% reduction of NO_x (e.g. -75% CAEP/6) for Flightpath 2050[17]. The cruise NO_x targets were also incorporated with the same reduction level as for LTO NO_x.

1.4.3 NASA N+1, N+2 and N+3

In order to develop new subsonic transport low emissions technology that could achieve the Technology Readiness Level (TRL) of 6, NASA established three goals that are distinguished by the time frames and emissions levels, namely N+1 (i.e. by the time frame 2015), N+2(2020) and N+3 (2025)[18] [145]. Both LTO and cruise NO_x emissions targets were included in the goal metrics: -60% CAEP/6, -75% CAEP/6 and -80% CAEP/6 for LTO NO_x and -33%, -70% and -80% relative to year 2005 best technology for cruise NO_x. Specifically, the N+1 and N+2 values are referenced to a single aisle aircraft (i.e. 737-800) with CFM56-7B engines and N+2 is to a twin-aisle aircraft (i.e. 777-200) with GE-90 engines [18].

2 Low Emissions Combustion Technologies

2.1 Rich-Burn Quick-Quench Lean-Burn Combustors (RQL)

2.1.1 Working Principle

The working principle of RQL belongs to rich burn emission controlling mechanism. The concept is schematically depicted in **Figure 6**, where the combustion is initiated by a fuel-rich mixture in the primary zone with equivalence ratio normally 1.2-1.8. The rich burn generally has a twofold advantage: 1. the combustion stability is enhanced due to rich burn producing a high concentration of energetic hydrogen and hydrocarbon radical species. 2. The NO_x production is minimised due to relatively low flame temperatures and low concentration of oxygen containing intermediate species. The hot efflux gas from the

primary zone contains a high amount of CO, UHC and smoke that cannot be exhausted without further processing [20]. Therefore, a quench section is employed downstream of the rich zone. A large proportion of dilution airflow is admitted into the quench section to oxidise CO, hydrogen and hydrocarbon intermediates. However, the addition of airflow may lead to a zonal equivalence ratio close to the stoichiometric value, resulting in rapid formation of thermal NO_x, as shown in Figure 8. To achieve low NO_x production, therefore the air has to mix rapidly with the primary zone effluent such that it can be quickly switched from the rich burn to the lean burn mode to minimise the formation of thermal NO_x, as shown the bottom route in Figure 8. This process is then followed by the lean burn section being employed to further consume CO and UHC such that an exhaust at the exit of the combustor contains a major combustion production of CO₂, N₂, O₂ and H₂O. The lean burn section is also responsible for controlling the combustor outlet temperature distribution quality. Typical equivalence ratio in lean burn is in the range of 0.5-0.7.

2.1.2 Key Technology Review

The concept was introduced in 1980 by Mosier et al [21] as a strategy to reduce oxides of nitrogen (NO_x) emissions from stationary gas turbine engines using fuels that were high in fuel-bound nitrogen. One of most distinctive features for RQL approach compared to the conventionally designed combustor is the modification of combustor stoichiometry distribution for reduced NO_x Emission. This is realised by air flow distribution and therefore, a less complex fuel scheduling system is required compared to lean fuel staged combustor. The early development of the RQL technology is based on conventional combustors. Relatively low development cost and short development time can be achieved because conventional design rules can be adopted when applied to RQL.

There are two major concerns when RQL technology is applied to conventional combustors: one is how rich the system can burn, and the other is how effective the quench can be supplied through standard air admission by dilution jets [22].

Rich burn: The first concern is initially addressed through the optimisation of primary zone flows to control stoichiometry: the dome front end is fuel rich at high power to ensure it addresses the principal emission challenges, namely NO_x and smoke. At low power condition it is close to the stoichiometric value to achieve high combustion efficiency and stability. This approach has been commonly adopted by main Original Engine Manufacturers (OEMs) [23] [24] [25]. The typical air flow distribution for dome, inner and outer passage flows are around 30%, 40% and 30%, respectively [26]. The distribution of bulk equivalence ratio among different zones in RQL combustor represents only a rough guide to emissions reductions. The actual values are heavily dependent on effective fuel-air mixing, namely mixing quality. Pratt & Whitney has developed the TALON (Technology for Advanced Low NO_x) family of RQL combustors for commercial aircraft gas turbine

engines. The recent TALON X combustor utilises a type of high shear injector, as shown in [Figure 7](#), to enhance the fuel vaporisation, distribution and fuel-air mixing. The injector is composed of a fuel nozzle and a compound radial inflow swirler [\[28\]](#). Fuel is spread onto a large diameter filming surface, on which a thin film forms and leads to very small droplets and rapid fuel vaporisation. Air is introduced into two passages: inner and outer, where high swirl initiated to enhance rapid mixing with fuel droplets. Atomisation is then enhanced when fuel vapours discharge at the atomising lip into the interface between the two swirling airstreams. The spray zone angle and primary zone aerodynamics can be modified by changing the swirl angles of two air swirling passages, and airflow split between them [\[27\]](#). GE's RQL technology named LEC (Low Emissions Combustors) has developed several mixers (i.e. swirl cup combined with dual orifice pressure atomisers): wherein different configurations of swirl cups were developed (i.e. radial or axial, twin-row radial swirlers with counter or co-rotating directions) with optimised air split between primary, secondary and flare air intended to create uniform fuel-air mixture [\[29\]](#).

Effective quench: As previously discussed, it is critical that rapid mixing is achieved to complete combustion of the rich mixture exiting the primary zone with minimum NO_x production. The technologies for improving quench effectiveness are realised through different approaches by OEMs. These may be described as follows:

1. **Closer spacing between primary and quench jet:** This method essentially entails the quench holes locations being moved towards the primary holes. It comprises two benefits: one is to enhance the quench mixing strength with primary air; the other being acceleration of the switching process from the rich burn to the lean burn. This approach is commonly adopted by P&W in TALON I [\[44\]](#) and GE's LEC combustors [\[29\]](#). The resulting effect of reduced temperature in the quench zone is shown in [Figure 8](#).

2. **Through the optimisation of jet hole pattern including the spacing, size and geometry:** Numerous studies have been conducted to investigate the jet penetration, structure and flow field distribution resulting from jet mixing in jets in crossflow. Focused research has been conducted on single and multiple jets, bounded and unbounded [\[31-37\]](#). Jet orifice geometries have been extensively studied and design methodology for cylindrical and rectangular configuration for a confined flow has been proposed by Cranfield to determine an optimum hole size with given momentum-flux ratio [\[38\]](#). NASA also conducted numerous non-reacting flow studies of jets in crossflow to evaluate geometrical features including hole spacing, shape, flow area, etc. The investigation leads to the determination of the optimum number of holes. Recently, the TALON X developed an optimised single row of dilution holes with a focus on circumferential and size location variation based on

the jet mixing experiment and gas sampling instrument as well as the in-house analytical tools [29].

3. Reduced combustor residence time in the quench zone: The NO_x production increases with flow residence time. As described in section 2.1.1, as the gas travels from the rich burn to the lean burn, the region where rapid NO_x forming mixture strengths are inevitably existent. It is important the time spent by the mixture in these regions is minimised. This approach is adopted by TALON X and is realised by optimisation of the combustor volume and distribution of combustor area as a function of length. The resulting residence time for TALON X has been reduced by a factor of 2 compared to older TALON used in the PW4098 engine, and the corresponding emission index of NO_x at take-off consequently is reduced by a factor of 3. The Phase 5 combustor technology by Rolls-Royce has also successfully optimised this approach [24].

4. Adding the local cooling air: Figure 9 shows a typical axial gas temperature distribution along an RQL combustor and NO_x emissions which normally peak at the quench section. GE LEC designed a series of small local cooling holes (Figure 10) downstream of the primary holes: this effectively reduces the local peak gas as well as near wall temperatures, leading to a further reduction in NO_x and higher liner durability. This design feature has been patented [39].

Liner wall cooling: in addition to the two major issues this is also of concern for RQL technology, primarily due to two reasons: firstly due to larger content of carbon in rich burn higher luminous radiation is observed, because of which the inner liner wall surface temperature rises significantly and the peak temperature forms near the quench section; the second is because the RQL technology demands a larger proportion of dilution air for rapid quenching, it results in limited quantities of remaining air available for cooling. In order to address this concern, several advanced cooling technologies have been employed in RQL combustors. Examples include P&W adoption of combined impingement and film cooling in TALON combustors and the recent TALON X which adopts an optimised float-wall configuration for cooling and achieves higher cooling efficiency with a usage of 20% combustor exit air compared to 33% for baseline PW4084 combustor [29]. The RR phase 5 combustor utilises tiles on the supporting shells that effectively decouples the mechanical stresses from the thermal stresses, and the tiles can be cast from blade alloy materials that have higher temperature capability (>100°C) than typical combustor alloys. Also, the introduction of ceramic structures for ultimate cooling flow reduction has been considered in RR RQL technology improvements [40]. If dome film cooling is used to provide a protective layer for preventing convective heat transfer from high temperature gases, the presence of cooling air enables the NO_x formation toward the high NO_x route. In some design, the atomising air is arranged to flow over the outside of liner wall in rich zone

before entering into the fuel nozzle such that regenerative backside convective cooling is implemented to alleviate this problem.

In addition to improving the quench effectiveness that is crucial to NO_x reduction, the dilution jets also serve the purpose of improving the exit plane mixing which is crucial to pattern factor reduction and hence improved turbine life. An advanced CFD-based analysis system, named Allstar has been developed at Pratt & Whitney, which has been used to optimise combustor exit temperature distribution. The CFD code was initially verified by comparing the predictive turbine profile with data measured in full annular rig tests for three aero gas turbine combustors. **Figure 11** shows one of the results for a PW4098 combustor. It captures the major features in exit plane temperatures and shows a consistent temperature distribution with rig test data. In subsequent research, the code was used to assist the optimisation of the PW6000 combustor exit temperature profile. It was accomplished by investigating the effect of dilution hole pattern changes on the exit temperature profile, and a direct correlation between the dilution hole pattern and pattern factor was established [41,42].

Continuous effort is made to design the new generation of the TALON X combustor by P&W in a recent NASA ERA program, the research is focused on swirler injector design, and aims to further reduce the smoke and NO_x emissions [43]. In summary, the RQL approach has been implemented for many years in gas turbine combustors. It is a reliable, relatively lower cost approach with many advantages in meeting the full range of combustion system requirements.

2.1.3 Technology Application

Pratt & Whitney has developed the TALON family of RQL combustor for commercial aircraft gas turbine engines. The first generation, TALON I, that powers PW4098 entered into service in 1999 with flight hours of 145345 hours (37761 cycles), no unscheduled engine removals and no in-flight shutdowns reported [44]. Second generation, TALON II which fits in PW6000 engine entered into service in 2005 and demonstrated the improved service and achieved further emissions reduction. Recent TALON X was used in PW1500, PW1130G-JM, PW1133G1-JM, etc. It has demonstrated NO_x reduction by 25% compared to TALON II in rig and engine tests [45]. RQL combustors have also been used for other engines such as new Rolls-Royce Trent 1000 with rated thrusts 268kN-350.9kN with OPRs 36.3 -46.1 and GE's CFM56 series with rated thrusts ranging over 97.9 kN-142.3kN and with corresponding OPRs 23.1-32.6. Early RQL combustors such as V2500 have longer axial length because of extra space required for quick quench and lean burn. The ratio of liner length to height is 2.24 compared to 2.0 for conventional combustors [47]. Modern TALON II and X achieved design goals while maintaining similar length as conventional combustors. Overall RQL combustors are applied from small to large engine categories for

a wide range of engine thrust and OPRs.

2.1.4 Emissions status and characteristics

The low emissions technology is commonly assessed by plotting take-off EI_{NOx} denoted as the emissions index of NOx emission. It is defined by the amount of NOx produced in gram, per kilogram of fuel (i.e. unit g/kg) as a function of engine OPR since NOx emissions are impacted by combustor operating conditions (i.e. Pressure, temperature and residence time) and modern engines have comparable thermal efficiencies and overall fuel-air ratio for given thrust levels.

The NOx emissions analysis for recent RQL in-service products including GE P&W and RR was performed in [25], based on ICAO engine emissions testing database. The analysis concludes that RQL technology from different OEMs yields a very similar result in terms of EI_{no_x} as a function of OPR. Figure 12 gives the details. Based on the similar emission index characteristics, a correlation was proposed subsequently and shown in the same figure. For LTO NOx emissions levels, reference [40] indicates that the typical modern rich burn combustor technology delivers NOx in the range of 55-70% CAEP/6 for small engines intended to power regional jets and 55-65% CAEP/6 for medium sized engines. RQL technology produces higher soot production with normally an order of magnitude higher than lean burn technology. The amount of smoke is determined by the capability of the combustion system to consume the smoke within the chamber. However, the recent RR Phase 5 RQL combustors control the smoke to a constant characteristic number: 6.5. Recent sector rig testing conducted by P&W for new TALON development indicated that the NOx level of 72% margin to CAEP/6. These promising results indicate that the RQL is still considered as a viable approach for the current aero combustors.

2.1.5 Summary of Technology Advantages and Challenges

Technology Advantages

As previously discussed in the section 2.1.1 through 2.1.4, the main technology advantages for RQL are summarised as follows:

1. The dome rich burn provides a high level of resistance to flame out, particularly at low power where the combustor is running very lean and the dome fuel air ratio is close to the stoichiometric value (i.e. relative high temperature can be maintained to enhance the combustion efficiency and stability). As a consequence, this technology demonstrates high reliability with excellent service history.
2. Relative low development cost and short development time since it is based on conventional combustion technology, empirical approaches and conventional design rules can be readily adopted.

3. The lack of oxygen due to rich burn discourages the oxidation of fuels, which prevents the conversion of fuel bound nitrogen to HCN and NH₃ that react with combustion radicals to form NO [48]. Instead, it converts fuel bonded nitrogen FBN into nonreactive N₂ [49].
4. It is advantageous in meeting the full range of combustion system requirements in addition to those of emissions since the requirements of safety, relight capability, operability etc. are considered as high priorities.

Technology Design Challenges

As previously discussed, the main technology design challenges are summarised as follow:

1. The airflow distribution needs to be optimised to control smoke/soot emission.
2. The higher OPR engine makes it much more difficult to contain NO_x level without changing the fuel injection concept. Advanced fuel spray nozzle is needed to improve the fuel-air mixing.
3. The advanced cooling scheme is required for optimum use of dilution jet for quenching and improved liner durability (i.e. higher luminous flame radiation due to rich burn).
4. Cooling of the dome should be carefully designed to avoid NO_x formation toward the high NO_x route

2.2 Double Annular Combustors (DAC)

2.2.1 Working Principle

The double annular combustors adopt a radially staging strategy. The working principle is schematically shown in Figure 13. The combustion stoichiometry and hence temperature is controlled through the use of fuel injection in multiple combustion locations. At low power settings, part of combustion zones operates and refers to the pilot zone (i.e. the outer annulus) (Figure13) to raise the equivalence ratio (around 0.8) so as to increase the combustion efficiency and reduce CO and UHC. The pilot zones which are represented by outer circumferentially arranged circles and red colour indicates the injectors are fuel filled and operating. The local high combustion stoichiometry also mitigates the risk of lean instability. At higher power settings, typically at approach condition, zones that are called main (i.e. the inner annulus) get fuelled and ignited. The equivalence ratios for both zones are usually kept at 0.6 [9]. The objective is to achieve lean combustion for NO_x and smoke reduction at high power. During mid-power, part of the main zone is fuelled and operated, this aims to increase the transition efficiency and more than one staging point is employed.

2.2.2 Key Technology Review

The concept of DAC was first conceived by Bahr and Gleason in the 1970s [51]. The most distinctive feature from the configuration perspective is the twin radially arranged combustion zones. The two zones are separated by a centre body (CB in Figure 12), this essentially helps to minimise local quench (thus the reduction of CO and UHC) of the pilot flame by main air flow at low power conditions where only the pilot zone is alight. The resulting effect is the extension of the radial height. This contributes to larger surface area than single annular combustors (SAC) and hence, cooling tends to be demanding and less air is available for the lean burn. Especially at high power, dome front end equivalence ratio raises resulting in higher EI_{NO_x} . Higher OPR DAC engines are more susceptible to this problem. For example, GE90 with PR=40, even though it has multi-hole cooling, the cooling requirement is too high and primary zone equivalence ratio is 0.9 at high power [10]. This design challenge would limit its further development for future ultra-high OPR engines.

On the other hand, the radial configuration enables the combustion goals including low emissions, stability, efficiency, etc. to attain reduced length and weight. This is advantageous for reducing problems such as rotor dynamics, resulting from length since the shaft torsional vibration is directly proportional to its length.

The fuel staging is through the change of the fuel splits into different zones according to change in power conditions while maintaining the unchanged airflow distribution. To achieve this, a more complex fuel control system and the addition of fuel manifolds, are required compared to the conventional single annular combustor. The fuel nozzle used in DAC features a twin-fuel nozzle tip that is attached to the commonly shared feed arm, as shown in Figure 14, as power conditions change, in order to provide the rapid response of fuel supply into the different combustion zone both main and pilot system are fuelled in advance. This increases the potential risk for fuel coking. Coking refers to the hard carbonaceous compounds formed in the internal passages of the fuel system when the fuel undergoes pyrolysis reactions when it is heated in the absence of air. Such compounds can block or reduce the flow of fuel through the main stage hardware. However, the commonly shared feed system enables the pilot fuel flow to continuously flow over the outer side of the main flow, providing the protective cooling. In order to effectively direct the airflow into separated zones, a double passage pre-diffuser is employed on GE90 engines series and the studies were conducted under NASA/GE Energy Efficient Engine (E3) programme. The study reveals that the 50% of reduction in pre-diffuser length can be achieved compared to a single passage configuration having the same area ratio [52]. Several rig tests have been conducted to measure the overall pressure loss coefficient, and the loss contributes to 35% of the total combustor pressure loss [53].

Control of pattern factor presents a major challenge in the development of DAC: the less dilution air available in DAC has a difficulty in mixing the pilot and main streams to achieve ideal exit temperature profile. Furthermore, since injectors are radially arranged, more hot spots could form at the exit plane of the combustor. The temperature outlet distribution has been experimentally investigated under the E3 program with the goals set for a radial temperature distribution factor (RTDF) of 0.125. Baseline sectors and modified versions have been investigated. **Figure 15** shows the measured profile at idle. The pilot stage is only operating at idle, yielding an outer peak average profile of 0.6 with the maximum profile factor (PF) of 1.2. The effects of fuel flow split between the pilot zone and main zone on exit temperature profiles as well as NO_x emissions are also investigated at simulated take-off condition. The study indicated that with lowest pilot flow split the RTDF of 0.3 and PF of 0.5 were obtained for minimum NO_x production. The increase in pilot flow split generally decreases both RTDF and PF but leads to an increase in NO_x emissions.

The radial temperature profile design challenge not only compromises the turbine durability but also impacts on the turbine work extraction efficiency. As a consequence, higher mission fuel burn is required compared to the single annular version. The deficient temperature profile, especially during idle condition, causes a 7%-15% increase in SFC at idle compared to its corresponding single annular version **[55]**.

The transition of fuel staging occurs at mid power (e.g. approach 30% power) where the main zones are also operated in addition to the pilot zone. The local fuel-air ratios, temperature, pressure of main zones are not as high as those at high power. The combustion efficiency and stability are unfavourable. This affects engine acceleration. More recent designs apply more than one staging points. As shown in **Figure 13**, an extra staging point can be applied at mid power such that part of the main zone is brought into operation, which raises the local equivalence ratio to enhance the efficiency and improve the staging smoothness. Yet, this introduces complexity for fuel control, and additionally the circumferential staging results in non-uniformity temperature exit, and challenges in turbine durability.

2.2.3 Development and Application

The product was introduced into CFM56-5B, 5B/P, and 7B models during the year 1995-1998. The GE90 also adopted this design; the engine was tested in February 1995. The CFM56 series DAC combustors are introduced to power Airbus A320 and A321 aircraft. The GE90 series now power the Boeing 777 aircraft **[56]**. In general, this type of low emissions combustors usually applies to the engines in medium and large categories with rated thrust in the range of 102.2kN (CFM56-5B9/2P DAC) to 504.9kN (GE90-113B DAC) **[57]**.

2.2.4 Emissions status and characteristics

Figure 16 summarises the ICAO LTO characteristic emissions for DAC combustors for the CFM56 series (i.e. CFM56-5B DAC; SLS thrust level of 117.9-133.5 and OPRs 27.1-31.2 and CFM56-5B DAC II; thrust levels of 120.1-142.4 kN and OPRs 27.7-32.8) and GE90 DAC versions (SLS thrust level of 363.4-426.7 kN and OPRs 35.3-40.6).

Overall, all the DAC versions yield a similar trend for NO_x emissions. As engine OPRs increase up to around 32, the DAC combustors demonstrate NO_x emission levels with overall 20 % margin from the CAEP/6, the margin widens gradually at lower OPRs with a 40% margin obtained at OPR=24.6. This generally shows a wider NO_x margin compared to RQL combustors. However, very narrow margins occur as engine OPRs tend to increase. One of the possible reasons stems from the demanding cooling flow due to the larger surface area resulting from the radially arranged configuration; less air is available for lean combustion.

A comprehensive emissions assessment for the DAC technology was performed by Mongia. The idle EI_{CO} versus EI_{NO_x} for several CFM's and GE's DAC combustors against rich dome combustors are analysed by Mongia based on the ICAO emissions databank [58]. The main observation shows that DAC technology is competitive with rich dome combustors at lower OPRs for a trade-off between the CO and NO_x emissions, as indicated in Figure 17. However, higher EI_{CO} and EI_{NO_x} are produced at increased engine OPRs. The main reason for having higher CO emissions at idle is primarily due to the quenching effect between the two combustion domes. The UHC emissions yield the similar trends. The smoke emissions for DAC (Figure 18) are generally lower than RQL combustors with the overall level below 6 over the OPR ranges shown. Nonetheless, the considerable amount of smoke generated in the CFM56-5B DAC shows a relatively high level. The possible reasons may be attributed to the following:

- 1) The radial arrangement limits the space available for consuming the smoke downstream of the rich pilot flame zone at lower power.
- 2) The main unfuelled air when mixing with the pilot gas in the downstream mixing zone lowers the zonal temperature, which slows down the rate of soot consumption.

2.2.5 Technology Advantages and Design challenges

Technology advantages

As discussed in section 2.2.1-2.2.2, the technology advantages for the DAC are summarised as follows:

1. The radially staged configuration enables performance to be attained within the length comparable to a single annular version. The rotor dynamics problem is effectively reduced.
2. The commonly shared feed arm enables the pilot fuel to cool the main fuel, lowering the risks for fuel coking.
3. The lean combustion is operated at high power providing the potential to reduce the NO_x emissions.

Technology Design Challenges

The technology challenges for the DAC are summarised as follow:

1. Control of pattern factor and turbine transverse quality
2. Excessive mission fuel burn due to the radial profile design challenge
3. Challenges in cooling due to larger dome surface areas
4. Unfavourable transition combustion efficiency in the mid power range.

2.3 Axially Staged Combustors (ASC)

2.3.1 Working Principle

The axially staged combustors have a similar working principle as of the DAC but fuel staging is achieved through the fuel injection zones placed in the axial direction. As shown in [Figure 19](#), the pilot zone is placed at the upstream of the combustor, and main is placed downstream. The zonal equivalence ratios are similar to the DAC for different power conditions (i.e. Low power pilot averaged $\phi=0.8$ and high power both pilot and main having averaged $\phi=0.6$) unlike the DAC, the pilot and main zones have an arrangement for two separate fuel delivering systems.

2.3.2 Key Technology Review

The concept of axially staged combustion was conceived roughly in the same timeframe as DAC in the 1970s. The technology was developed by Pratt & Whitney in the NASA Experimental Clean Combustor Program ECCP. The baseline engine is the PW JT9D engine [\[13\]](#). Later, it was utilised as a low emission alternative for the baseline IAE V2500-A5 engine in the 1990s. For many reasons including business decisions, the ASC has not been introduced into service today [\[15\]](#). However, in recent years, the ASC has been reconsidered for further development by P&W in the NASA TRA program [\[59\]](#) [\[60\]](#).

Since the main stage of the ASC is downstream of the pilot, it has good combustion stability for the pilot because of the elimination of the local quench effect from the main unfuelled airflow. On the other hand, from the main perspective, the upstream hot gases from the pilot provide a continuous source of heat, and ignition from the main is rapid and

reliable. As a consequence, the pilot hot gases improve the main combustion efficiency and stability with the ability to assure low CO, UHC. However, due to the separated fuel nozzles arrangement for the pilot and main, the main fuel nozzles cannot be cooled by pilot fuel as previously discussed in DAC. Moreover, the main injectors are immersed with hotter gases from the upstream pilot. Therefore, fuel coking became an issue. The arrangement for the pilot and main zones poses a challenge for the casing structural integrity. The pilot and main system require separated penetrations of the combustor casing, from the structural perspective, requires a higher casing strength and stiffness.

The axially staged combustors, in general, have longer axial length compared to the conventional combustors. In order to address this, the packing of the main stage becomes a concern. In the V2500 ASC's design, the pilot zone is located toward the centreline of the combustor and the main zone is outboard and downstream of the pilot. The inboard location of the pilot is believed to reduce the susceptibility of lean blowout during heavy rain since the compressor centrifuges the water toward the outer portion of the flow path. Also the outboard location of the main peaks the temperature toward the tip of the blade so as to maintain the designed temperature profile during operation, effectively reducing the problem of profile deterioration. The in-line arrangement presents a major challenge (i.e. the local pitch radius of the combustor is difficult to be collinear) A large misalignment between two stages results in larger pressure losses of flow because the flow path is not smooth from the design perspective.

In the recent NASA TRA program, P&W conducted further development for ASC and termed this technology as Axial Controlled Stoichiometry ACS. The pilot system relies on experience gained in developing TALON combustors. Therefore, the pilot stage was kept simple and no significant change was made. To address the packing of the main, the new ACS intends to have a simpler fashion than the early V2500 version. Various designs for the main were conceptualised. There are two configurations for the main that are developed so far in ERA Phase I and Phase II: In phase I, the pilot injectors are located on the front dome and main injectors are placed on both top and bottom of the combustor downstream of the pilot. For phase II, main injectors are placed on top only. The schematics drawing for both configurations are shown in **Figure 20**. In this manner, both configurations effectively address the main packing issue with smoother flow path obtained compared to V2500's fashion. In addition to this, the higher upstream temperature results in the main stage burning the fuel with a high efficiency even with a low residence time. As a consequence, the length of ASC can be effectively reduced to some extent. As discussed previously, the NO_x is a function of residence time; this assures the low high-power NO_x emissions.

In order to achieve further reduction of NO_x emission, the design of the main mixers is created with the assistance of the CFD analysis. However, due to the main mixers being

still under development, and limited information released in public domain, detailed analysis for this main mixer is challenging.

2.3.3 Technology Application

The early ASC combustors were intended to be used in the IAE V2500 engine, a two-shaft with BPR=5 and thrust level ranging from 105kN to 140kN. The engine series power the Airbus A320 family. The new P&W axially staged combustion developed within the NASA ERA program were intended to be applied on advanced Geared Turbofan GTF engines with high Bypass Ratio BPR of around 12 and higher OPR (i.e. exceeding 60) for the next generation of propulsion engines.

2.3.4 Emissions Status and Characteristics

Figure 21 illustrates the NO_x emissions as a function of engine power for conventional and staged combustors. It is believed that 40% reduction in LTO NO_x can be achieved by staged combustion, and 50% reduction in cruise NO_x. **Table 3** summarises the emissions results for baseline V2500 engine and axially staged model. A reduction of 43% for EI_{NO_x} at take-off is achieved. The idle CO emissions of EI_{CO} Idle=4.1 is achieved for the axially staged engine, which demonstrates the potential of reducing the problem of high CO emission at low power as in DAC combustors.

The ACS combustor 3-sector rig testing was completed at NASA Advanced Subsonic Combustion Rig (ASCR). The test yields very low NO_x emissions for the LTO NO_x emissions and has been verified to be -88% (**Figure 22**), relative to CAEP/6 for Phase I and -76% relative to CAEP/6 for Phase II, thereby exceeding the ERA project goal of 75% reduction [43]. Moreover, the efficiency testing was also performed, indicating 99.9% at full load condition [59, 60]. Cruise NO_x was also investigated and EI_{NO_x} is less than 2 at typical cruise conditions for an advanced Geared Turbofan (GTF) cycle.

2.3.5 Summary of Advantages and Design Challenges

Technology Advantages:

As discussed in 2.3.1-2.3.2, the technology advantages for the ASC are summarised as follows;

1. The good combustion efficiency and stability for the main stage are attributed to higher upstream temperature provided by the pilot.
2. The rapid and reliable ignition for the main are due to similar reasons mentioned in 1.
3. The lower level of NO_x at high power that can be achieved for reduced residence time since the main stage can burn efficiently.

Technology Design Challenges:

1. There exists a fuel coking risk due to separated arrangement for the pilot and main. Main fuel cannot be cooled by the pilot fuel and the main injectors are immersed within hotter ambient temperatures from the upstream pilot gases.
2. The pilot and main system require separated penetration of the casing, thereby requiring higher casing strength and stiffness.
3. The packing issue of the main is a concern due to possibility of large misalignment for the pilot and main zone, thereby posing a challenge in maintaining low flow pressure losses.

2.4 Twin Annular Premixing Swirler Combustors (TAPS)

2.4.1 Working Principle

It is more appropriate that, TAPS technology is categorised as partially premixed combustion based on the mechanisms although some literatures term this as LDI or LPP [46][70]. Figure 23 shows the concept schematics. At first sight, the configuration is very similar to conventional single annular combustor SAC, however, the main difference lies in the fuel injector heads, wherein TAPS adopts internally staged partially premixed technology. It is composed of pilot and main stages with both concentrically mounted. The pilot uses a simplex atomiser (other means including pure or piloted airblast have also been investigated) to spray the fuel onto the pre-film lip where it is atomised in an air blast mode between the two axial air streams. The fuel sprays interact with the surrounding co-rotating or counter rotating swirl to generate a pilot recirculation zone (Termed PRZ in Figure 23) which stabilises the pilot flame. The pilot only mode operates to maintain sufficiently high combustion efficiency and stability at low power including ignition through to idle. At higher power, the main is also turned on, and partial premixing is achieved through the mixing of the discrete liquid jets issuing radially outward into the premixing channel (i.e. cavity) with high swirling air stream generated from Cyclone swirlers (indicated as a cross in Figure 23). The main flame is stabilised in the mixing layer between pilot and main. The small recirculation (termed LRZ in Figure 23) is crucial as it stores radicals from the pilot combustion which stabilises the main flame. The airflow split for GENx TAPS is such that 70% of the air flows through the mixer and the remaining 30% is for dome and liner cooling with no air for dilution. In summary, the TAPS combustor evolved based on lessons learned with fuel staging of DAC, and also benefited from the experience with Dry Low Emissions lean premixing combustors in aero-derivative industrial gas turbines [62].

2.4.2 Key Technology Review

As previously discussed in section 2.2.2 the approach of the DAC has some degree of difficulty in meeting the turbine profile requirement without which optimum turbine work

cannot be extracted. Multi-concentric flame technology development which mostly applied in single annular combustors (SACs) has been a new focused research, which leads to TAPS combustion technology. Several key technologies are reviewed as follows:

Premixed Combustion: This is one of the most distinctive features in TAPS and successfully applied into the aero application. The premixed combustion is realised by the main mixer in TAPS. [Figure 24](#) shows a typical configuration: The mixer is composed of a radial inflow swirler and a fuel injector where the tip has holes drilled in single or double rows. The multi-point injection is realised by these circumferentially drilled fuel orifices, therefore providing the evenly distributed fuel to be mixed with air in the primary zone. The radial swirler imparts a higher tangential velocity to initiate the radially inward airflow in order to realise the rapid mixing process with fuel within a bounded cavity. Although early TAPS development relied heavily on experimental rig testing followed by data analysis, the role of the CFD in the development process is considered to be beneficial. In the GENx TAPS combustor development process, CFD analysis was utilised in design optimisation. For example, RANS analysis was performed to optimise the pilot and main fuel-air mixing for low NOx. Specifically, the number of main fuel jets, axial location and orifice diameters are the main parameters to optimise the circumferential and radial fuel distribution at the exit of the main mixer [\[63\]](#). [Figure 25](#) illustrates the optimisation studies. The local hot spots are therefore effectively reduced and liner durability is improved since less luminous flame radiation transferred to the liner with uniform lean burn. In premixing passage of TAPS combustor, the risk of auto-ignition is of primary concern as it can occur at sufficiently high temperature, pressure and residence time. The premixing devices could be damaged if the flame is stabilised there. The prediction of auto-ignition time is therefore necessary in the design of the premixing system to assure the flow residence time must not exceed it. Several experimental studies were conducted by Liang et al, Zhukov, Shariatmader et al. and Guin [\[64-67\]](#). It turns out that for high OPR engines (of over 40) and inlet temperature (of over 900 K), the auto-ignition time would be less than 1ms. Therefore, to mitigate the risk for auto-ignition, the allowable premixing passage shortens. This poses a challenge for premixing since complete premixing cannot be achieved within a short passage. The resulting effect is the compromise for mixing quality. In order to address this concern, GE has developed different main configurations: instead of having a single radial inflow swirler, an additional axial swirler was also utilised intending to further improve the fuel air mixedness without increasing residence time in the premixing passage, leading to low risk for auto-ignition as well reduction in NOx emissions [\[68\]](#). The resulting effect is more complex fuel injection system and good thermal management for nozzles because the increased cross-sectional area promotes the heat transfer process of the incoming hot combustor inlet air and nozzle wall. Another issue of concern is flashback. Unlike the pilot for DAC which is closed to the spark plug and ignition is rapid, the fuel spray from the TAPS pilot have to cross the main flow field to achieve ignition. The corner

recirculation zone (CRZ) helps to transport the pilot sprays to the spark plug to achieve quick ignition. However, the presence of CRZ could result in flashback that causes periodic combustion unsteadiness. The detailed explanation is provided by Huang and Yang [69]. This reference explains that a part of reactants in the main flow are detained in CRZ, and heated by the pilot flame. The flame speed is then increased such that the flame can propagate upstream through the CRZ. As the flame consumes the reactants in the CRZ, it reaches the upstream wall of the combustor and is extinguished due to no more reactants available. At this point, new reactants fill the CRZ and the process repeats itself and drives the periodic unsteadiness.

Internally staged configurations: This configuration has an advantage over DAC in maintaining the desired combustor exit temperature distribution. The twin annular flame applied in a single annular combustor enables the temperature to peak near the top centre of the blade. In this manner, the turbine life can be improved as well as the reduction in mission fuel burn, as previously discussed. On the other hand, the internally staged system poses a design challenge because the spark has to achieve ignition across unfuelled main zone airflow. The quenching of the spark would compromise the ignition capability. However, GE has successfully addressed this issue, and altitude relight tests were performed. Steady state windmill capability to altitudes in excess of 30,000 feet has been demonstrated. However, limited information released in the public domain explains how this is realised.

Flow characteristics: The flow characteristics of TAPS contain a very distinctive feature compared to that in the conventional combustors. The recirculation zone in the pilot presents a difference for non-reacting and reacting conditions. The planar laser induced fluorescence (PLIF) and particle image velocimetry (PIV) diagnostics have been conducted by Sulabh K et al [70]. The study observed that, with non-reacting flow, the central recirculation zone displays an ellipsoidal shape with the flow moving towards the upstream direction which is similar to the central recirculation feature captured in a conventional combustor. However with reacting flow, the recirculation zone is toroidal with flow moves downstream. The two features can be seen at the bottom of [Figure 26](#). The explanation of the change in flow direction, as demonstrated experimentally, is due primarily to the geometry of the fuel injector and blockage of the main flame causing more airflow through the pilot. The study also investigated the twin flame interaction, and concluded that the stabilisation of the main flame is realised by a shear layer between the pilot and main flames where it stores the radicals from the pilot combustion. The size of the shear layer determines the flame stability as well as NO_x emissions. Therefore, knowledge is required for detailed flow dynamics and heat release analysis at mixing layer where the main flame is stabilised. The velocity gradient in the mixing layer should be maintained at different off-design conditions such that the flame is less prone to blowout or flashback.

Pilot Mixers: As for all staged combustion, the pilot system is used to maintain the combustion stability particularly at low power. A pressure atomiser was chosen in early development. Several other configurations are also developed including air blast or piloted air blast system. One of the most distinctive pilot designs is shown in [Figure 27](#), GE has developed a type of active combustion dynamic control device, namely a plasma generating nozzle, such that the pilot fuel passes through it and causes in-situ dissociation of fuel into partially decomposed components of fuel into hydrogen. This can effectively help to extend the lean blowout margin because hydrogen has wider combustion stability range with lower lean blowout limit. The technology was eventually patented and intended for industrial applications.

Fuel coking is generally undesirable because it increases the risks for blocking the internal and external passage of the fuel injector, leading to reduced fuel discharge rate, component life and undesired fuel spray characteristics. However, during the development for TAPS I, GE observed that the occurrence of carbon deposits on the pilot exit outer wall is beneficial to improve the idle combustion efficiency. They termed this effect as good karma or good coke [\[68\]](#). This observation leads to a later patented design for pilot exit outer wall that aims to reproduce the effect of carbon deposits. The details of the design can be found in [Ref. \[143\]](#), however, limited information is in the public domain to explain the details.

Zero dilution zones: A traditional approach for improving the combustor downstream mixing and temperature exit distribution is through the optimisation of dilution holes. Since the fuel-air mixing is significantly enhanced by TAPS mixers, the need for adopting additional dilution holes seems unnecessary. The large fraction of air and pressure drop are utilised for lean premixed combustion, which further limits the addition of dilution zone. However, on the other hand, the elimination of large dilution holes from TAPS, in fact, reduces the local stress concentration of the liner. In this sense, the liner structural integrity can be effectively improved. Furthermore, since the dilution zone is eliminated, the length of the combustor can be made shorter so that it can be applied in smaller engines where size and weight are primarily important.

Advanced liner material: Higher OPR engines require combustor liners to be able to withstand higher temperature. Ceramic matrix composite liner material is proven to withstand higher temperature while using less cooling airflow. Recent development for new generation of TAPS, TAPS III, includes utilisation of CMC materials with advanced cooling. The rig combustor test successfully demonstrated the material capabilities of the CMC combustor liners, which will be the first continuous CMC combustor liners in a commercial jet engine [\[72\]](#).

Additive manufacturing technology: The complexity of the fuel injection system highly demands advanced technology for manufacturing. The new TAPS III combustor features fuel nozzle tips manufactured using additive technology [\[72\]](#). For example, in patent US

8,806,871B2 the fuel nozzle comprises at least one component made using a rapid manufacturing process. The rapid manufacturing process is a laser sintering process.

Overall, TAPS demonstrates the high capability for achieving ultra-low NO_x emissions, high combustion efficiency, desired exit temperature profile and operability, enhanced liner durability and effective control in combustion dynamics, etc. The new generation of TAPS will be developed based on previous experience from legacy TAPS design. The new TAPS concept will focus on further reduction in NO_x emissions, aiming to achieve the NASA N+3 goals. To attain this goal, an even larger proportion of air greater than 70% compared to previous TAPS [73], would be employed for ultra-lean combustion. At the same time, the focus of the research is also placed on further enhancement of fuel-air mixing. A series of design challenges including combustion instability, system reliability, trade-offs between emissions and operability, the complexity of control for fuel staging and combustion dynamics, etc. would be present with the progress of the development.

2.4.3 Technology Application

The development of the TAPS combustor started in 1996 [74], under GE and NASA sponsored programmes. (e.g. AST and UEET) The early development efforts involve the technology demonstration in GE DAC engines in the late 1990's. Later in the early 2000's primary focus of development was shifted to single annular combustor (SAS) versions of TAPS. The SAC TAPS was demonstrated in a CFM56 7-B engine. Eventually, TAPS transitioned to the GENx series of engines, as shown in Figure 28. It entered into service in 2010 and now powers wide body aircraft, the Boeing 747-8F and 787 [61]. The first emissions certification data for GENx TAPS was completed in October 2009 and was undertaken for 13 models, whose OPR range from 35.1-46.5 and rated thrust of 255-345kN.

After the successful integration of TAPS combustors to larger engines, GE and Federal Aviation Administration (FAA) launched the program for scaling TAPS technology, namely TAPS II, to narrow body applications. TAPS II is intended to be implemented as a part of LEAP engine for powering the COMAC 919, Airbus A320 NEO and Boeing 737 Max [75]. More recently, TAPS has been applied to power different classes of thrust and pressure ratio including the current GE *Passport*, powering Bombardier Global 7000/8000 business jets with rated thrust level of 74kN and pressure ratio of 22 [76].

2.4.4 Emissions Status and Characteristics

The LTO engine testing NO_x emissions levels for current in-service TAPS combustors for different OPRs (i.e. 35.5 -47.0. with corresponding thrust levels of 255.3 -345.2kN) engines are summarised in Figure 29. The Genx TAPS combustors demonstrate a remarkable NO_x emissions reduction levels. The margin is 60% from CAEP/6 at OPR around 35 and 40% margin at higher OPR around 47.

The recent TAPS III technology adopts Ceramic Matrix CMC liner in a TRA project and

by the end of the phase I, a 5 sector testing was performed that has achieved the project emissions goals of NO_x (i.e. 75% reduction relative to CAEP/6) at TRL level of 4 [73]. **Figure 30** summarises the testing results. In the meantime, the measurement for simulating cruise NO_x and efficiency were also performed and data resulted in up to 70% reduction in EI_{nox} compared the 2005 state-of-the-art and over 99.9% efficiency obtained at TRL of 4.

2.4.5 Summary of Technology Advantages and Design Challenges

Technology Advantages

As discussed in 2.4.1-2.4.2, the technology advantages for TAPS are summarised as follow;

1. Ultra-low NO_x emissions due to premixed combustion demonstrate the potential in achieving long term NO_x goals.
2. Improved combustor exit temperature distribution due to internally stage configuration. This enhances the turbine life and reduces the mission fuel burn (i.e. engine SFC).
3. Liner life is significantly improved due to the introduction of the advanced CMC liners. The liner temperature is reduced as well as the cooling flow. Thereby allowing more air to be utilised for ultra-lean combustion.
4. Improved liner structural integrity due to elimination of the large dilution holes that cause the local stress concentration.
5. Advanced fuel nozzle manufacturing technology enables the complex fuel nozzle system to be applied in the further application.

Technology Design Challenges

The main design challenges include the following aspects:

1. Control of the auto-ignition and flashback due to premixed combustion, rapid mixing is therefore required to avoid exceeding of the auto-ignition delay time.
2. Good thermal management is required for fuel nozzles due to complexity of the fuel injection system.
3. Combustion instability requires knowledge of detailed flow dynamics and heat release analysis at critical regions such as the mixing layer.
4. Due to the internally staged configuration, good ignition is required since the spark has to achieve ignition across the unfuelled main airflow.

2.5 Lean Direct Injection Combustors (LDI)

2.5.1 The Rolls Royce LDI Combustors

2.5.1.1 Working Principle

The LDI works by injecting the fuel directly into the combustor chamber and quickly mixing the fuel with a large fraction of air. By adopting LDI, the peak flame temperature at medium to high power can be reduced if fuel and air can be well mixed before the reaction is completed. Since a greater proportion of air has to be introduced through the injector, dilution air is greatly reduced or eliminated [77]. As shown in Figure 31, the LDI injector occupies much of the dome area so as to pass the large fraction of the total air. The air split for RR LDI combustor is such that 60-70 percent of air passes through the injector system and the remaining air for cooling [78]. Like TAPS, the RR LDI combustor is also fitted with an internally staged singular annular configuration. Pilot and main are concentrically mounted. The pilot nozzle has two versions: pressure atomising type and airblast. The main nozzle uses airblast. The pilot and main flow field are separated by a splitter which sets up a wake, called bifurcated flow field leading to the separated pilot and main flame. At low power, the pilot operates and the flame is stabilised in the bifurcated flow field to sustain the combustion efficiency and stability. As power is increased, the main mixture is injected into the main bifurcated flow field, and the wide cone angle leads to rapid fuel evaporation and low residence time regions for low NO_x at high power. A lean blowout at idle at equivalence ratio of 0.04 has been achieved. As power is increased to approach, the fuel flow at pilot is reduced and part of main is fuelled. At cruise to full power, approximately 10% of fuel enters into the pilot and 90% goes to main. At full power, the local equivalence ratio at main is 0.6-0.65 to minimise NO_x emissions [78].

2.5.1.2 Key Technology Review

Since modern civil engines have increasingly high OPRs in order to reduce engine SFC, the combustor inlet pressure and temperature significantly shorten the ignition delay time which presents a great challenge for premixed combustion. In order to further reduce the emissions, a direct injection method becomes a preferred option. Several key technologies in RR LDI combustors are discussed as follows:

Lean direct Injection: As the fuel is directly injected into the combustion zone, it mitigates the risks of auto-ignition and flashback. In order to achieve a high degree of mixture uniformity, fuel and air have to be well mixed before the reaction takes place, in other words, rapid mixing has to be achieved within a short distance once fuel is issued from the injection system. As indicated in Figure 33, RR LDI adopts the prefilmed airblast

injector for the main that combined with two-stage axial air swirlers to enhance the process of the fuel-air mixing with reduced flow residence time. Since a large fraction of air passes through the injector head and also the introduction of the axial swirlers for rapid mixing, the resulting effect is a large cross-sectional area which promotes heat transfer, as previously discussed good thermal management is required to reduce the coking risk. Additionally, due to increased size and weight of the injectors, stress and vibration would be other issues. These affect the casing integrity since it has to withstand higher stresses.

Internally fuel-staged configuration: Similar to TAPS, RR LDI employs this configuration with an aim to reduce the combustor surface areas while improving combustor exit temperature distribution compared to DAC technology. The internally staged configuration may pose an ignition challenge, as previously discussed in TAPS combustors. However, this concern has been addressed successfully by RR: the investigation of the engine windmilling ignition (i.e. altitude relight) was conducted by the E3E Core Engine Test Programme. The engine test demonstrated satisfactory results indicating full windmill relight loops, achieving it at altitudes beyond 30000 feet [135].

Another concern for fuel staged combustion is to achieve optimum fuel split (i.e. split is the ratio of pilot fuel flow to total fuel flow). The effect of fuel split on emissions and detailed flame characteristics has been experimentally investigated through digital imaging and measurement of heat release by OH* chemiluminescence. Figure 32 shows the flame (top) and OH* chemiluminescence. The main observation from the study indicated that, for low pilot fuel split, the pilot and main heat release zones are separated (left) with low NOx emissions produced. On the other hand, with high pilot fuel split, both flames are merged into a single one and the NOx emissions are increased. The effects of fuel split on combustion efficiency and NOx emissions were further experimentally investigated by RR. Engine condition is at cruise with combustor inlet pressure $P_3=9.4$ bar, $T_3=713$ K and AFR=30. The study concluded that a very strong influence of fuel split is prevalent on NOx and efficiency, and the optimal range for fuel split at this condition for low NOx and high efficiency is 30%-45% [133].

Two-step fuel staging strategy: In order to contain higher flexibility for fuel staging, RR LDI add another staging point such that the staging utilises pilot alone for idle, pilot and part of the mains for approach, and pilot and all mains for cruise and higher power conditions. The two-step staging is achieved essentially by staging in circumferential direction, similar to one in Figure 12. The continuous variation with fuel in open and closed position, during operation is achieved by the fuel control system. Therefore, the complex fuel scheduling system is required in the design. The research investigated combustion efficiency and compared it with RQL. It is observed that deficient combustion occurs at mid power. It is primarily due to the main combustion being quenched by the adjacent

unfuelled main airflow. Therefore, optimisations of burner-to-burner interaction as well as fuel injector configurations etc. are required for further technology refinement.

Bifurcated flow field: This is the one of the most distinctive features in RR LDI. For fuel-staged combustion, the pilot and main flames are usually separated such that the combustion in each zone can achieve its best purpose (i.e. low power stability and high power low NO_x emission). The way of addressing this is the key technology. RR LDI realises this by utilising a patented device called a splitter [81], as shown in Figure 33. The result is such that the flow structure is created as a bifurcated pattern, with the pilot flow having a smaller pilot recirculation zone and the main flow having a wide cone angle. The former has a benefit in maintaining pilot flame stability because it minimises the interaction with cold main flow during engine low power compared to the conventional larger central recirculation zone. The latter has benefit in producing the lower high-power NO_x because of wide cone angle, resulting in reduced residence time and hence rapid mixing. There is an interaction zone between pilot and main flame through turbulence driven by vortex breakdown and shear layers. This critical region presents a design challenge wherein as the pilot is operating rich, the main is quenching the reaction and hence compromising ignition, LBO and combustion efficiency. As the main stage is operating lean, fuel preparation and combustion efficiency are adversely affected. Thus, the pilot flame needs to sustain the main combustion. The interaction is influenced by many factors. A key factor is the swirl strength within the pilot and main, the effect of pilot swirl strength on ignition and lean blowout was investigated by RR at atmospheric conditions. Figure 34 shows the different pilot flames with weak and strong pilot swirling strength. The weak swirling strength features a narrow cone angle, whereas a strong swirling strength provides a wide cone angle of flame. The study concludes that the high strength flow generally improved ignition performance, but compromised the lean blowout. Other factors including geometrical characteristics of flare, (i.e. converging and diverging passage of the outer main swirler) as well as other parameters within the injection system and combustor dome were identified to have an effect and need to be optimised.

Advanced cooling system: To efficiently cool the liner wall the design uses effusion and tiles cooling schemes. Double skin walls are also used where heat-resistant tiles are attached to the liners to take the thermal load so as to decouple the thermal and mechanical stresses. The cooling of tiles is accomplished by an impingement effusion where air impinges the outer walls (cold side) through an array of holes and merges as a film at exit to the inner walls (hot side) such that the film cooling scheme is subsequently initiated.

2.5.1.3 Technology Application

The LDI concept has been investigated in the framework of NEWAC, New Aero Engine

Core concepts. The objective of the programme was to develop and validate the lean combustion technology up to TRL 5-6, demonstrating 60% to 70% reduction of NO_x emission against LTO CAEP/2 standard while maintaining the combustor full operability. Within the NEWAC programme, the LDI targeted the potential high pressure ratio engine applications (i.e. OPR>30) including inter-cooled (IC) core concept, flow-controlled (FCC) core concept and active core (AC) concept. Figure 39 illustrates that the LDI combustor is a part of the E3E core engine components whose HP system demonstrated a pressure ratio of 22:1. The LDI is subsequently further investigated in a programme called LEMCOTEC (Low Emission Core Engine Technology) as a continuation of programme after NEWAC. The LDI is targeting the potential large turbofan cycle that aims at an overall pressure ratio up to 70. It is designed for a long range mission and the core module is integrated in the advanced 3-shaft engine architecture. [54] The objective of this programme with respect to emission is to attain and exceed the ACARE 2020 goal on CO₂ and NO_x. (50% and 80% reduction respectively with reference to the technology year 2010) [55], The RR LDI combustor is reported to demonstrate a NO_x reduction of 60% against the CAEP/6 at TRL 6 for an engine with pressure ratio of 39. In summary, current TRL for LDI is approaching 7; the emission performance may however degrade once the TRL 9 is achieved. Details of design features for this technology can be found in [80-82].

2.5.1.4 Emissions status and Characteristics

Limited emissions data are available in the public domain for RR LDI because it is still under development and the current TRL has not reached 9. No ICAO certified data have yet been produced. The NEWAC report [83] claims that a 70% reduction of NO_x emissions relative to CAEP/2 is attained by this technology. Figure 35 shows the same result based on first full annular testing in the programme. The engine testing for the E3E core that fits RR LDI combustor was performed in the subsequent development. The tests have indicated NO_x levels in the region of 35% to 45%, relative to CAEP/6 have been obtained, which shows a 30% to 35% reduction compared to rich burn [40].

2.5.1.5 Summary of Technology Advantages and Design Challenges

Technology Advantages

As discussed in 2.5.1.1-2.5.1.2, the technology advantages for RR LDI are summarised as follows;

1. No risk of auto- ignition and flashback compared to premixed combustion.
2. Ultra-low NO_x emissions due to premixed combustion demonstrating the potential in achieving long term NO_x goals.

3. Improved combustor exit temperature distribution due to internally stage configuration. This enhances the turbine life and reduces the mission fuel burn (i.e. engine SFC).
4. Liner life is significantly improved due to the introduction of the advanced cooling system as well as less luminous radiation resulting from lean burn.
5. More staging points lead to more flexible fuel staging intended to improve the part load lean staged combustion efficiency and operability.

Technology Design Challenges

The main design challenges include the following aspects:

1. Rapid mixing should be achieved before the reaction takes place.
2. The pilot and main flame interaction require trade-offs such as ignition capability and lean blowout, NO_x/smoke and CO/ UHC emissions.
3. Good thermal management is required for the fuel nozzles due to complexity of the fuel injection system.
4. Combustion instability demands knowledge of detailed flow dynamics and heat release analysis at critical regions such as the mixing layer.
5. The large injector head requires a strong casing strength.

2.5.2 The NASA LDI Multipoint Injection Concept (MLDI)

2.5.2.1 Working Principle

The working principle behind the NASA multipoint injection concept is that: the fuel is distributed to a number of points in the fuel path, as shown in Figure 48. Therefore, a conventional single injector is broken down into a number of separated injectors where each of them is fitted with air swirlers to provide a local quick and uniform mixing and small recirculation zone (Figure 36) for burning to provide shorter burning residence time. The uniform mixedness and shorter residence time contribute to lower NO_x production. A lean burn is combined with this to achieve ultra-low emissions. NASA achieved the solution to generate matrix combustors composed of small LDI injectors [85-87]. As with other lean burn combustors, all of the air excluding air for liner cooling enters through the combustor dome.

2.5.2.2 Key Technology Review

Multipoint injection: This is the most distinctive feature for the MLDI concept. An

effective way to distribute the fuel uniformly into the combustor zone is the minimisation of the size of the fuel injectors. Instead of having a conventional single large injector, it is broken down into a number of separated injectors. A sector test was performed with advanced laser diagnostic imaging utilised by NASA to evaluate the fuel distribution for a multi-injection configuration. Ref. [151] gives the details of the facility and testing method. Views of the fuel distribution were obtained using Planar-Laser-Induced Fluorescence PLIF [150]. The fuel distribution is colour coded using a logarithmic scale. Figure 53 shows the end view of the fuel distribution image by PLIF for the middle of the array section of the MLDI. It can be seen that a relatively uniform pattern for fuel distribution was obtained just 5mm downstream of the injection dome, showing that a rapid mixing process can be realised by this technology. Because of this, the combustor liner length could be reduced, which remains attractive because it has the potential for compact low emissions combustors if part load operation issues can be resolved. Another benefit is control of outlet temperature distribution: since the fuel distribution is uniform, the temperature distribution can be actively controlled by regulating the fuel-air ratios for each injector. Therefore, a desired radial temperature profile at combustor exit can be tailored via optimising the local fuel-air ratios for each injector. This leads to a further benefit wherein the dilution zone can be eliminated. This therefore leads to a further reduction in combustor length.

NASA has investigated the different numbers of the multi-point such as 9, 25, 39 and 49 points with 9 points studied as baseline concept. Also, the 9 point MLDI has been tested with an inlet pressure of up to 5500kPa under the NASA Glenn High Pressure Low NOx Emissions Research Scheme. Overall, the first generation of SV-LDI demonstrated a substitutional reduction in NOx emissions: with an assumed cooling fraction of 15%, the measured LTO NOx emission is 63% below CAEP/2 standard [88]. Each injector is composed of a simplex atomiser, an axial flow swirler and a venturi. The matrix configuration from this concept imposes a challenge for manufacturability: the densely packed structure demands high manufacturing technologies to minimise the dimension discrepancy tolerance for each injector. If fuel staging is applied, high flexibility of fuel control and supply is essential. Moreover, the air and fuel distribution should be carefully designed to ensure each local burning zone produces lower emissions while maintaining good stability. Increasing pressure loss generally decreases NOx emissions. It is caused by increasing the cold flow bulk velocity, which in turn decreases the residence time. However, with an allowable range of pressure losses (e.g. $\Delta P/P_3 \leq 5\%$) the current concept is still far from a homogeneous reactor. In addition, the flame front is closed to the injector face due to small recirculation formed; fuel coking is another design issue. Furthermore, the shorter residence time imposes a design challenge for altitude relight because it depends on the volume of recirculating flow downstream of the injectors. This reduces approximately in proportion to the number of injectors [89].

Fuel-staged configuration: Perhaps one of the main challenges for multiple injections is to minimise the local quench between the adjacent injectors such that the low power operability, as well as emissions of CO and UHC, can be controlled. In order to achieve this goal, a second generation SV-LDI concepts has been developed. There are 3 distinctive second generation SV-LDI concepts that were developed by the Parker Hannifin Corporation (Figure 37), Goodrich Corporation (Figure 38) and Woodward FST (Figure 39), respectively.

A 3-zone MLDI developed by the Parker Hannifin Corporation consists of 15 fuel-air mixers arranged in three outwardly-canted panels in place of a single conventional fuel injector, as depicted in Figure 37. The three zones are formed by canting the side fuel nozzles away from the middle to minimise the interaction between the injectors [90]. Each panel is fed by a separate fuel circuit and becomes a staged zone. Each mixer is composed of the air passage and the air swirler with the fuel nozzle inserted through the centre of the swirler body. Three stages are categorised by the pilot, main 1 and main 2. The pilot operates only at light off condition and pilot and main1 are used at lower power conditions where the overall fuel air ratio is relatively low; pilot, main1 and main2 are all operating at higher power. The Goodrich MLDI [94-95] concept consists of 5 row radially staged injectors in place of a conventional single injector. The pilot is located in the centre row and surrounded by two rows of intermediate injectors. The remaining two rows of the outer injectors are located in the outer ring. Fuel staging is also applied, with the pilot operating at idle condition and as power is increased; the intermediate injectors also brought into operation, followed by all injectors with the outer ones operating at high power conditions. The Woodward FST concept consists of two configurations: flat and 5-recess MLDI. (Figure 39) A large pilot is located in the centre of the matrix, surrounded by main injectors which are main1, main2, and main3. Each of the main has 4 identical configurations. Table 4 provides detailed parameters for both configurations. Both main 1 use simplex injectors and main 2 and main 3 use airblast. The angles of air swirler for main 1, main 2 and main3 are the same (i.e. 45 degrees) though swirl orientations are different. The major difference between flat MLDI and the 5-recess model is a recess made for covering pilot and main1 in the 5-recess model. The design aims to improve the lean operability during low power conditions. The fuel stage zones are fed by 3 fuel lines with main 2 and main 3 having the same supply [91].

In summary, the 2nd generation of NASA MLDI had made two major technology improvements compared to 1st generation: the first is the effective fuel staged configuration (either in form of outwardly-canted as in Parker Hannifin, or the pilot is recessed as in Woodward FST) that minimises the quench effect between adjacent injectors, leading to reduced CO and UHC emissions; furthermore, the increased staging points as in Goodrich

MLDI (i.e. main 1, main 2 and 3) also enhance the engine full range of operability. The second is the simplification of the injector configuration that is achieved by either reducing the number of injectors or enlarging the pilot. The resulting benefits include: the ease of manufacturing such that dimension discrepancy tolerance for each injector can be minimised, and effective control for fuel coking: because the flame recirculation zone is increased due to the enlarged pilot, and the distance of the flame is further from the injector tip. Finally, the larger pilot flame recirculation zone improves the ignition capability as well as enhances the low power operability.

The reduced number of small injectors could compromise the fuel-air mixing quality. In order to achieve identical or better fuel-air mixedness for lower emissions combustion, significant efforts in the study were put into investigating the dynamics of mixing and combustion processes. However, these cannot be completely described through experimental investigation. NASA has developed the National Combustion Code (NCC) that helps to investigate both non-reacting flow and reacting flow. NCC has been used to analyse both single [146,147] and multiple injector LDI configurations [149,148]. Comprehensive CFD studies [96-98] were performed to evaluate combustion characteristics of multi-Lean Direct Injection combustion systems (LDI-1) so as to prepare a tool to provide guidance for defining and refining the next-generation LDI-2 and LDI-3. Non-reacting computations were performed to enable extensive comparison of axial-velocity, radial-velocity, tangential-velocity, and turbulent kinetic-energy with experimental data [92]. Figure 40 shows the axial velocity contour along two planes for a single component. Predictions of emissions (EI_{nox} , EI_{co} and UHC) were also performed to compare with the two sets of experimental data representing respectively the low-pressure and high-pressure engine cycle condition [93]. Figure 41 shows a comprehensive summary of the NCC EI_{nox} predictions. Seventeen different flow conditions with varying pressure drops, fuel-air ratios and fuel-staging between the Pilot stage and the three Main stages were computed with the NCC. The NCC predictions for EI_{nox} were within 30% of the Woodward FST experimental data.

New generation: NASA continues to develop a 3rd generation MLDI configuration based on the 2nd generation Woodward FST design. The new configuration comprises a central pilot injector and four surrounding main injection elements. The developed CFD code NCC was used to perform parametric studies on effective area and flow characteristics for various configurations in order to derive an optimal configuration to further improve the fuel-air mixing [144].

By the end of NASA ERA Phase I that ended in 2015, the 2nd generation of MLDI has demonstrated the ignition, flame propagation, lean blowout capabilities and NOx reduction

through experimental testing. Assessment of NO_x reduction for the intermediate pressure rig would be the next progress for Phase II [90].

2.5.2.3 Technology application

NASA multi-point injection concepts aim to meet Environmentally Responsible Aviation (ERA) goals of 75% NO_x reduction for advanced 55:1 pressure ratio and 70,000 lb thrust engine applications [95].

2.5.2.4 Emissions status and characteristics

The Parker Hannifin configuration was tested in a flame tube test facility at NASA Glenn Research Centre. The inlet pressure varies from 0.69 to 1.72MPa and inlet temperature from 590K to 830K. Based on the correlations obtained from the tests, a 66% NO_x reduction relative to the CAEP/6 is estimated at a high pressure ratio of 55 [99]. The Goodrich concept was also tested at the NASA Glenn Research Centre. The inlet pressure is at 55psia and temperature at 496K. Based on the extrapolation of the rig test data, the calculated EI_{NO_x} at take-off is 26.8 g/kg at FAR of 0.035 and at a 55:1 pressure ratio. This is believed to attain and exceed the ERA goals of 75% NO_x reduction (also NASA N+2 goal) [88]. The Woodward concept is tested at NASA Glenn Research Centre and the testing has been completed at an inlet pressure of 1790kPa and inlet temperature up to 855K. Results show that the recess configuration generally has lower EI_{NO_x} than that of the flat configuration. Correlations have been developed, and demonstrating around 88% in NO_x reduction relative to the CAEP/6 standard, which exceeds the ERA goals [91]. Idle HC and CO testing were performed for the Goodrich concept with three sets of testing conducted at pressures of 72,81,82 psi, temperatures of 534,537,538 K and turbine cooling and leakage air (TCLA) of 0%,10% and 15% respectively. Results are listed in Table 4 and comparisons of results were made against GE90 data. Overall, the MLDI yields lower idle HC and CO than the DAC version [95].

2.5.2.5 Summary of Advantages and Design Challenges

Technology advantages

1. Local uniform fuel-air mixture with rapid mixing can be achieved through the distributed small recirculation of flame. The resulting benefit is the reduction of the combustor length and hence low NO_x. Little soot is formed as well.
2. Temperature distribution can be actively controlled by regulating the local fuel air ratio in each small injector.

3. The recess and outward canted configurations alleviate the local dilution of the flow at the boundaries of fuelled and unfuelled sectors, thus suppressing excessive formation of CO and UHC.

Technology design challenge

1. Densely packed structure demands high manufacturing technology to minimise the dimension discrepancy tolerance for each injector.
2. Good thermal management is required due to small flame recirculation that close to injector, coking is an issue.
3. With allowable pressure losses, the mixing quality from this concept cannot achieve a completely homogeneous fuel-air mixture.
4. The shorter residence time imposes the design challenge for altitude relight.

2.6 Lean Premixed Prevaporised Combustors (LPP)

2.6.1 Working Principle

For liquid fuels, the Lean Premixed Prevaporised (LPP) combustor appears to be most promising for ultra-low NO_x combustion. The concept is schematically depicted in [Figure 42](#). Fuel is first vaporised and then mixed with the air flow to create a homogeneous mixture before entering the combustion zone and burning at a low equivalence ratio that is close to the lean blowout limit. NO_x emissions are drastically decreased because of the low flame temperature and the elimination of hot spots from the combustion zone. A typical LPP combustor is divided into 3 regions: the first is for fuel injection, vaporisation, and fuel-air mixing such that completed fuel evaporation and fuel-air mixing can be achieved; the second is for combustion where the flame is stabilised in the recirculation zones and the third may comprise a conventional dilution zone. The long time required for full fuel evaporation and fuel-air mixing at lower power conditions could result in auto-ignition or flashback in the fuel preparation duct at higher inlet air temperatures and pressures associated with high power settings.

2.6.2. Key Technology Review

Uniform Mixing: With a homogeneous mixture of low equivalence ratio by LPP, NO_x is decreased to a minimum level due to low flame temperature and uniform mixing. In addition, soot formation can be effectively eliminated because of the elimination of the local hot rich-burn; consequently, the liner durability is greatly improved. Another important advantage is that for a well premixed LPP combustor, the flame temperature does

not exceed 1900K and NO_x is not increased with increase in residence time. Therefore, lean premixed combustors can be designed to have a longer residence time to minimise CO and UHC while maintaining low NO_x [101]. This is important for industrial applications where size plays a less important role. A typical example is the GE's lean premixed LM6000 aero-derivative engine; the combustors being shown in Figure 43. From the figure, one can observe that the new premixed system is about twice the conventional LM6000 in size, which supports the previously stated advantage of reducing CO and UHC by increasing the combustor residence time.

Also, for a well premixed LPP system with operating flame temperature below 1900K, the NO_x formation is less dependent on combustor inlet pressure and temperature; this is unlike the traditional diffusion flame system where NO_x is a function of both combustor inlet pressure P_3 and temperature T_3 . This finding is based on data taken from a gas-fired LM6000 Lean premixed test by Leonard and Stegmaier. The test operates at P_3 from 1 to 30 bar, T_3 from 300 to 800 K and residence time varied from 2 to 100ms [101].

Auto-ignition and flashback: One of the most crucial design challenges for the LPP system is preventing the occurrence of auto-ignition (spontaneous ignition) or flashback inside the LPP injection system when combustor P_3 , T_3 and residence time in the premixing passages are high. The injection system could be damaged if a flame is stabilised in the premixing passage. The primary design criterion for a premixer is the determination of ignition delay time, which is defined as the time interval between the creation of a combustible mixture and onset of flame. Flashback occurs when the flame speed exceeds the gas velocity along some streamline and propagates upstream of the combustion zone and into the premixing passage. Lean burn often decreases flame speed, however with high temperature, pressure and turbulence intensity, which cause increased flame speed. It often occurs through the flow boundary layer along the premixing passage walls because the flow velocity there is lowest [102]. Also, flashback can be driven by combustion oscillation during which high amplitude of pressure oscillation can be formed with positive pressure gradient; the local flow velocity is decreased below the flame speed [67]. Flashback is also driven by combustion induced vortex breakdown and hence if the mixture inside the vortex bubble moving upstream is within the flammability limits, flashback could occur [102].

Therefore, in order to prevent premixing or flashback, the design of the premixing passage has to be made with its residence time less than the ignition delay time with a sufficient margin. This imposes a challenge for achieving full premixing and prevaporisation with a shorter premixing length. As previously discussed, no full premixing and prevaporisation within the premixing channels have been achieved so far for modern aircraft engines.

Since the LPP is burning fuel lean, close to lean blowout, the stability issues need to be addressed through the use of the pilot stage, which increases the complexity and cost. The very lean burn necessitates the efficient cooling schemes such as double-skin impingement

and effusion cooling because more air is used for burn hence less is available for cooling. Also, high altitude relight is difficult to achieve even with the presence of the pilot stage [103]. A variable geometry scheme needs to be employed to address the issue, which leads to the introduction of the concept in the following section.

2.6.3 Technology Application

The concept of LPP has been developed under the NASA Experimental Clean Combustor Program (ECCP) programme in the early 1970s. Under this programme, one of the GE concepts for replacing the baseline combustor of the engine powering large subsonic turbofans GE CF6-50 is a radial/axial staged combustor with a premixing main stage. The baseline engine has PR of 30 and max SLS thrust of 218kN [104]. The pilot in the concept has a conventional design, the main comprising a premixing channel with bluff body flame holders placed downstream. Each main fuel injection consists of a fuel bar with two circumferentially directed holes of 1.03mm diameter.

Later, the concept of LPP has been developed by GE and P&W under NASA Critical Propulsion Components CPC, as a part of the HSCT programme in the 1990s. The programme focuses on the NO_x reductions at supersonic cruise flight conditions [105]. The goals of the programme are to attain a cruise EI_{NO_x} below 5 g/kg while reaching the combustion efficiency of 99.9%. P_3 and T_3 of the combustor are 9 bar and 938K. In the end, the propulsion cycle and combustor selected are the mixed flow turbofan (MFTF) and LPP for the final development. The design has demonstrated the emissions and operability that meet the requirements of the programme. Detailed requirements can be found in Ref. [106]. Two LPP concepts have been conceived in the programme: LPP Stepped Dome SD concept and LPP Multi-stage Radial/Axial MRA concept, as shown in Figure 44 and Figure 45. Both concepts employ fuel staging architecture with cyclones pilots and premixing tubes named integrated mixer flame holder IMFH. The major difference is the layout of the staging zones: stepped dome arrangement is such that at least one of the annular sections of the dome is recessed relative to the others. This helps to isolate the pilot from the other injectors to decrease CO and UHC emissions that are of concern at low powers. LPP MRA was finally selected for the final development considering the advantages over SD with respect to fuel nozzle manufacturability, reliability, cost and weight, etc. No auto-ignition or flashback occurred during the flame tube and sector tests [106].

More recently, the LPP concept has been developed by Turbomeca under subproject (SP6) of the European New Aero Engine Core Concepts NEWAC programme which started in 2006 and was due for completion in 2011 [107, 108, 110]. Figure 46 illustrates a 3-D view of the design. The LPP concept is adapted to a reverse flow combustor that fits into an intercooled recuperative IRA engine of OPR < 25. Similar to previous LPP, it features a fuel staging with a pilot stage placed in the outboard position to maintain the stability at low powers [109]. Fuel premixing and pervaporation process are achieved inside the fuel

injection system duct, as schematically shown on the bottom right of the figure. The airflow is split into two: one devoted to fuel atomization through the high swirled air velocity, and the second for mixing and fuel evaporation in the duct.

The LPP is well adapted to the lower OPR engines (e.g. $OPR < 25$) because the lower inlet pressure and temperature minimise the risk of auto-ignition inside the injection system. A NO_x reduction of 57% versus CAEP/2 limit is validated on a full annular combustor test at the LTO cycles. Apart from light-up performance and operating life, a TRL of 5 has been reached. The expected entry into service is 2018 [108].

2.6.4 Emissions status and characteristics

Limited information is in the public domain, for recent LPP combustors developed in the NEWAC programme. A NO_x reduction of 57% versus CAEP/2 limit is validated on a full annular combustor test at LTO cycles [108]. The same results can be also seen in Figure 35.

2.6.5 Summary of Technology Advantages and Design Challenges

Technology advantages

1. Lowest emission can be achieved in principle with soot effectively eliminated.
2. Liner durability is greatly improved due to low flame radiation.

Technology design challenges

1. Auto-ignition and flashback risk become severe at higher OPR engines; this limits the further application for future gas turbines.
2. Higher lean blowout risk due to ultra-lean burn and staged combustion has to be employed with compromise in higher production for NO_x emission at engine part load.

2.7 Variable Geometry Combustors (VGC)

2.7.1 Working Principle

The working principle is schematically shown in Figure 47. The overall approach is to control the combustion stoichiometry in the primary zone by regulating the air flow through a variable geometry control system. As shown in the schematics, the air flow splitter is driven by a hydraulic system and is allowed translational movement (moves forward and backwards) to vary the cross-sectional area and hence the air flow ratio into the primary zone. At lower power conditions, the degree of opening of the splitter increases the quantity of air diverted backwards to create a high primary FAR and a reducing flow velocity for high combustion efficiency and improved stability, as well as good light-up capability. As

power is increased, the splitter opens, introducing more air into the primary zone to achieve low FAR such that lean combustion is achieved for the purpose of NO_x and smoke reduction. Another form of controlling the air flowing into the combustor zone includes the use of variable-area swirlers to control the swirling airflow which regulates the combustor primary zone equivalence ratio according to the power changes [111].

2.7.2 Key Technology Review

Potential to achieve all performance goals: The variable geometry combustor provides the most effective way of maintaining the primary zone temperature within the low emission ‘window’, thus it has great potential for reducing all the emissions without compromising its combustion performance at all operating conditions. In addition to this, the variable geometry system has proven to have an improved altitude relight performance. A test has been conducted to evaluate altitude relight capability for a ram-induction combustor for designed cruise Mach number $M=3.0$. The altitude relight capability can be achieved with an inlet pressure down to 0.238 atmospheres compared to 0.47 atmospheres with the conventional model by bypassing the primary zone air flow toward the outer transition liner thereby reducing the combustor reference Mach number. The test was conducted at ambient air and fuel temperature [112].

Control Schemes: In order to realise the control to achieve all performance goals as well as low emissions, several schemes based on air flow control with variable geometry combustor and fuel flow staging are proposed by Yi-Guang Li [113]. The control schemes include an introduction of flame temperature predictor to control the primary zone flame temperature at a set point value. The prediction of flame temperature is achieved with several engine operating combustor geometric parameters. The alternative simplified scheme was also implemented with flame temperature, essentially controlled through the relation between primary zone air and an indirect control parameter that is the non-dimensional fuel flow rate. The combined fuel staging was also investigated as another control scheme. The proposed schemes were applied to an aero turbofan engine model and results indicate that significant reduction of emissions at ground level can be achieved with the control schemes working effectively at cruising altitude. In addition, the dynamic performance of the variable geometry combustor was also investigated by Yi-Guang Li *et al.* The study observed that during engine transition process; the maximum moving rate of the control system (i.e. the hydraulic driven system) may delay the air splitter (Figure 47) movement. However, this effect on engine combustor performance is not significant. Utilisation of variable geometries demonstrated the potential for improving combustion stability, efficiency and specific fuel consumption compared to conventional configurations [114].

However, the advantages achieved are at the expense of increased cost and weight due to the introduction of the complex control schemes. The increased weight significantly compromises its application for small and medium gas turbines, particularly for aircraft

engines where low weight is a primary design goal.

Flow distortion: the control scheme (i.e. sliding bands) has to move to an extreme position to satisfy the control target over the wide range of operating conditions; it causes flow distortion at the combustor zone and hence large pressure loss is encountered. The severe flow distortion causes challenge for liner durability because the cooling air flow in the combustor annulus passage is changed frequently and may move away from the design point. This also leads to problems of achieving the desired temperature pattern in the combustor efflux gases, especially if the liner pressure drop is allowed to vary too much.

Therefore, to reduce the range of the movement of sliding bands, fuel staging is often employed. The introduction of fuel staging again increases the complexity and cost of the system and decreases its reliability. Variable geometry should be used in conjunction with LPP to avoid local hot spots and high NO_x formation regions. Also, improved relight capability can be realised with this scheme for lean burn system.

2.7.3 Technology Application

The variable geometry concept has not been matured and therefore has not been currently applied for aero engines. It however has been used in large industrial applications. A typical example includes application on to a 120MW gas turbine in the 1090-MW LNG combined cycle plant in Japan [115]. However, the cost and weight of variable geometry systems are inevitably high because of the complex control and feedback mechanisms, with low reliability. For these reasons, it has not been applied on aircraft gas turbines. Reference [116] forecast the time scales for the application of different low emissions technologies and predicted the application of variable geometry on aero application only after the year 2020.

A number of variable geometry concepts have been proposed by several researchers, the typical low configurations can be found in Adkins [117] and Hayashi et al. [118], Schultz [119, 120], Gupta et al. [121], Fletcher [122] and Saintsbury and Sampath [123]. Furthermore, the variable geometry combustor has been developed for automotive gas turbines. Figure 48 shows the geometry of an LPP combined with variable geometry combustors used for a 100 horse-power engine by the Allison Division of GE Motor [124]. The combustor comprises a prechamber, a pilot and ignition chamber, and the main cylinder chamber of 127mm diameter. The prechamber contains a start injector located on the centreline of the combustor and main fuel injector. Air is introduced into the prechamber through both axial and radial swirlers. The premixed prevaporised fuel-air mixture flows into the main cylinder chamber through a 46.6mm diameter of the opening in the centre of the dome. Variable geometry is employed to control the FAR in the primary zone by sliding bands. The cross section areas of the radial swirlers of the prechamber and dilution holes can be controlled so that the amount of air flow can be varied. At low power, most of the air is admitted into the dilution holes. As power is increased the degree of the

opening in radial swirlers is increased. Air flowing through the radial swirlers merges and mixes with air flowing through the axial swirlers before entering the main chamber. At full power, additional air is admitted into the main chamber from the inlet ports through the dome holes. **Figure 49** shows the air split as a function of sliding location of the variable geometry system. The pilot stage is employed to maintain the low power stability.

2.7.4 Emissions Characteristics

The emissions prediction of variable geometry for aero application has been conducted by Pervier [103]. **Figure 50** shows the comparisons of NO_x emissions for LPP with and without variable geometry as a function of power setting. The emission of NO_x is predicted using stirred-reactor models whose layout is the same as that of AGT100 [103]. The combustor main chamber front end is divided into 2 regions: a flame front core for simulating the main chamber front end, and a flame front near wall for simulating the dome. The combustor inputs are adopted from the performance simulation of CF6-80E1A1 which powers A330 with a thrust rating of 300 to 320kN. The OPR=32.4 and BPR=5.3. Power is varied from 10% to 100% at sea level. The flame front core equivalence ratio is set to be 0.5. It can be noted that, at low power up to around 55%, LPP with variable geometry actually produces higher emissions than when compared with an application with fixed geometry. The reason for this is attributed to the air fraction to the near wall (i.e. dome in **Figure 48**) is close to stoichiometry, thereby leading to the increase in lean stability, combustion efficiency, and hence higher NO_x emissions. As power is further increased, a large fraction of air is diverted to the flame front core as well as flame front near wall such that the local equivalence ratio is low, thus a reduction of one magnitude of NO_x emissions is produced by variable geometry compared to the fixed geometry.

2.7.5 Summary of Technology Advantages and Design Challenges

Technology advantages

1. Reduction in emissions (NO_x, CO and UHC) for power conditions throughout the entire the flight envelope can be achieved by controlling the combustion stoichiometry through regulating the airflow.
2. High altitude relight capability can be achieved by passing the primary zone air flow towards the outer transition liner thereby reducing the combustor reference Mach number.
3. The part load operability is improved via the flexible controlling scheme.

Technology design challenges

1. Complexity of control system and higher cost.
2. Increased weight due to the introduction of a control system is a significant challenge for aero applications.
3. System reliability needs to be demonstrated with more rig testing.

4. Liner durability challenge arises from the cooling flow distortion in combustor annulus passage.

3. Review of performance aspects

Although emissions could be a focus when designing a typical low emissions combustor, the importance of other performance interacting with the emissions should be explored thoroughly. Therefore the performance should not be compromised when designing a low emission combustor. **Figure 51** shows the interrelated combustor performance for design considerations.

Safety is always the most important airworthiness criterion and there is no exception for low emissions combustors design perspective. The altitude-relight capability and avoidance of autoignition/flashback should be considered primarily during the early stage of the design. Stable combustion is critical as combustion instability could damage the hardware of the combustor and become a safety issue. Operability should be also considered as a high priority to ensure the combustor is capable of operating over a wide range of fuel-air ratios, (larger turndown ratio). The performance criteria such as combustion efficiency and pressure loss are always the key design considerations because the combustor design has to satisfy the whole engine requirement as SFC and total fuel consumption of the engine are proportional to the combustion efficiency. Pressure loss, as an important engine cycle parameter also affects the whole engine design, particularly for engine SFC. Size and weight are important for aero applications, particularly for small/medium aircraft. In order to meet the durability requirement, the component should be designed to ensure they are capable of operating over thousands of hours and flight cycles. The satisfactory downstream turbine thermal and life integrity should be achieved by improving the exit temperature distribution.

In addition to emissions levels, a number of combustion performance parameters are evaluated in a qualitative manner for the reviewed low emissions combustion technology. A performance matrix is provided in **Table 5** that would be used for design considerations. Justifications for each evaluation are provided in the following section.

3.1 Altitude Relight Capability

Rich burn combustors generally have a superior altitude relight performance than lean burn combustors. The reasons are the easier setup for richer fuel-air stoichiometry and less

susceptibility to local quenching because of staged configuration. Some of the future lean-burn combustor technologies may have greater difficulty in meeting the commonly stipulated (by airline customers) relight capability of 9143 metres (30,000 feet). Some manufacturers questioned the need for this level of capability, and 7620 metres (25,000 feet) is regarded as a satisfactory safety margin [46]. Some lean burn technologies such as RR LDI has achieved the relight capability of 30,000 feet from the E3E core engine testing [133]. Amongst the lean-burn technologies, MLDI is deemed to contain the least altitude relight capability. The shorter flow residence time by MLDI imposes a design challenge for altitude relight because it depends on the volume of recirculating flow downstream of the injectors. This reduces in proportion (approximately) to the number of injectors. VGC is believed to be most promising in maintaining a satisfactory relight capability because the dome air mass flow under windmilling condition and the corresponding equivalence ratio can be tailored to fall into the ignition stability loop with a sufficient safety margin.

3.2 Autoignition/flashback Risk

Autoignition/flashback is evaluated based on the type of flame, namely diffusion or pre-mixed flames. RQL, DAC, ASC, LDI, MLDI and VGC all employ the diffusion flame system. LPP adopts the premix flame to minimise the emissions, the risk of autoignition and flashback is theoretically the highest. TAPS uses partially premixed system for the main stage and risk is assessed to be moderate. However, since TAPS has demonstrated safety and achieved the FAA certification for this type of technology, it is reasonable to believe such risk is effectively controlled.

3.3 Combustion Stability

It has been a major issue in the design of aero combustors, and lean burn combustors are more prone to combustion instability. It arises due to the coupling between the unstable combustion process and acoustic disturbances within the combustion chamber. These self-sustained instabilities are more likely to occur in lean premixed combustion systems [142]. The mechanism is described in Ref. [138]: acoustic noise is generated during the combustion process with a broad frequency bandwidth [139]. These acoustic waves propagate inside the combustion chamber, interact with the boundaries and travel back to the combustion zone. These pressure oscillations generate in turn perturbations of the flow field by modifying the local flow rate, reactant composition or thermodynamic properties in the flame region, producing heat release rate disturbances [140, 141]. When heat release disturbances and pressure oscillations are in phase, the acoustic energy in the system is amplified and a resonance is generally observed.

In order to control the combustion instability, the mechanism of various acoustic dampers, such as perforated liners, Helmholtz resonators, baffles, half-and quarter-wave tube are

applied. The status, challenges and progress of implementing such acoustic dampers on engine system have been critically reviewed by D. Zhao and X. Y. Li [125]. Also, J Chen, D. Zhao, N Han and J Li conducted an experimental investigation on a cold-flow pipe to study the effect of different shaped orifice edges, porosities and mean flow Mach number on aeroacoustics damping performance for perforated liner application. The study observed that the edge shape of the perforated orifice and thickness to diameter ratio of the perforated plates do not significantly impact its sound absorption and damping performance. However, the mean flow Mach number and porosity of the perforated plate both play important roles in affecting noise damping. Another finding is that the effective damping frequency ranges of perforated plates are dependent on the length of the downstream duct. Other valuable information for perforated liner investigations can be found in Ref [126].

Fluctuations could result from perturbations in flow and fuel-air ratio oscillations because of the fuel staging. Furthermore, the range for stable rich combustion is wider than that for lean burn. (i.e. typical rich extinction limit is around equivalence ratio of 3 whereas the corresponding equivalence ratio for lean blowout limit is around 0.5[128]) As a consequence, RQL has higher combustion stability than the others. LPP is believed to have the lowest combustion stability in the absence of the fuel staging because it burns at a low equivalence ratio that is close to the lean blowout limit.

3.4 Combustion Efficiency

For modern aircraft engines, combustion efficiency is effectively 100% at take-off conditions. Relatively low levels of 98% to 99.5% can be seen at low power conditions. For take-off condition, the currently reviewed technologies all demonstrate high efficiency and achieved the design requirement (i.e.> 99.5%) with current RQL combustors having an efficiency of 99.9% at all high power conditions [7]. Since limited information explicitly quantifies the efficiency for some advanced low emission combustor, (e.g. LDI, TAPS, LPP) qualitative evaluation for the efficiency is based on the quality of fuel preparation, mixing and rate of reaction. The main reason that TAPS and MLDI have higher efficiency stems from the partial premixing system for the main stage of the TAPS and the higher degree of uniformity of fuel-air mixture due to multi-point injection. The even higher efficiency for LPP is due to higher quality of fuel preparation and mixing because of pre-vaporisation and premixing. The low power efficiency for the modern combustor has to be greater than 99.5%. Overall, the current reviewed low emissions combustors all have satisfactory low power efficiency. RQL combustors have idle efficiencies ranging from 98.8% to 99.3% [25]. For lean-burn combustors, the high idle efficiency is achieved through local rich burn due to fuel staging. ASC and VGC are believed to have higher value. The local quenching can be minimised due to axial staging compared to internally staging such as RR LDI and TAPS. For ASC, higher residence time is allowed for consumption of incomplete combustion compared to DAC. For VGC, the high efficiency due to favourable local fuel-air stoichiometry can be realised by regulating the right amount

of air flow via this technology.

3.5 Pressure Loss

It is challenging to obtain any significant increase in pressure loss due solely to the introduction of low emissions combustion technologies since 1% increase in pressure loss leads to approximately 1% increase in engine SFC, depending on the cycle of the engine [129]. Therefore, the currently reviewed technologies are designed to ensure the loss is in a reasonable range, typically ranging from 4%-6%. VGC presents more challenge in maintaining such a desired range compared to the others since the control scheme (i.e. sliding bands) has to move to an extreme position to satisfy the control target over the wide range of operating conditions. Additionally, it causes flow distortion at the combustor zone hence a large pressure loss. For MLDI, since mixing has to be achieved within a large number of small fuel-air mixers, the pressure loss could be increased through a number of small injectors. The allowable pressure loss, therefore, impacts the effectiveness on the fuel-air mixedness.

3.6 Combustor Weight

The DAC has a very high surface to volume ratio; this presents cooling challenges but also includes a penalty for extra weight. ASC also has a weight penalty due to increase in axial length, and introduction of the separate fuel feeding system. The heavy weight of VGC due to the introduction of the complex control system is a key design challenge. Despite the fact that MLDI has a relatively heavier injection system due to increased number of fuel injectors and corresponding air swirling and venturi assemblies, the liner length can be effectively reduced because the mixing quality is significantly enhanced due to the improved spatial dispersion of fuel by MLDI. Therefore, MLDI is believed to have a moderate weight as the other single annular combustor (SAC) versions.

3.7 Fuel Coking

For the ASC, cooling of the main injectors imposes a design challenge since the two stages require separated feed arms. The main fuel nozzles are immersed in the hot incoming gases from the pilot stage and cannot be cooled by the pilot fuel to reduce the coking. The flame front is close to the injector face due to small recirculation formed in MLDI. The fuel coking formed in the external surface area of MLDI system is a design issue. Furthermore, the internal fuel passage for the small size injector has been reduced in size, which increases the possibility of fuel coking, especially at high power conditions. For RR LDI, the fuel injector integrates an increased number of axial swirlers into the lean direct injection system, resulting in a larger wetted area. This promotes the heat transfer process between the hot inlet combustor air and injector walls. A higher risk for fuel coking could therefore be a design issue. However, as discussed in 2.4.2, coking could be considered as 'good coke' sometimes as it could be beneficial for improved idle combustion efficiency from TAPS development.

3.8 Liner Life

The thermal creep and low cycle fatigue are the two main failure modes that determine liner life. For thermal creep, the wall temperature and temperature gradient are dominant factors. For low cycle fatigue, the structural integrity plays a crucial role. RQL combustor is generally more susceptible to thermal creep than lean burn due to higher luminous radiation resulting from rich combustion. Furthermore, the dome cooling flow is admitted gradually, hence towards the high NO_x formation route, resulting in higher wall temperature. The DAC and ASC contain relatively larger liner surface areas that enhance the heat transfer process and hence wall temperature. The previously stated cooling issues for VGC impose a challenge in maintaining a higher liner life. Primary zone holes and dilution holes are eliminated in TAPS and RR LDI. Since local stress concentration near liner holes can be effectively eliminated, the cracking and therefore low cycle fatigue can be effectively controlled.

3.9 Exit Temperature Distribution OTDF/RTDF

Exit temperature distribution is usually quantified by two terms, the OTDF and RTDF. The OTDF (Overall Temperature Distribution Factor) is the ratio of the difference between the peak and mean temperature in the outlet combustor plane, to the combustor mean temperature rise.

The RTDF is similar to the OTDF but uses circumferentially averaged values and this determines the turbine blade life because the hub carries the largest stress and is susceptible to creep, and the blade tip is usually very thin and difficult to cool. Therefore, a typical radial peak temperature must not occur at both locations. As previously discussed the RTDF also impacts the turbine work extraction efficiency, unsatisfactory RTDF will increase mission fuel burn.

The OTDF ideally should be controlled to less than 0.2 [130]. The reviewed combustor technologies are believed to attain this goal except the DAC which demonstrates the challenge. This is particularly during low power conditions where the pilot flame is lit and less dilution air available downstream of the two stages as well as the shorter dilution length before the turbine nozzle. Similarly, the DAC presents more challenges in controlling the RTDF. Compared to the temperature distribution in the quench zone of an RQL combustor, premixed combustors should have the advantage to achieve a lower pattern factor. TAPS achieves the lowest pattern factor amongst DAC and RQL versions of GE engines [131]. LPP is believed to have the lowest pattern factor due to the near homogeneous mixture created and elimination of hot spots from the combustion zone. VGC presents a challenge of achieving the desired temperature pattern if the liner pressure drop is allowed to vary too much. (i.e. change in liner hole discharge coefficient C_D due to annulus flow distortion resulting from the frequent movement of the flow control slide mechanism, which subsequently results in dilution air flow variation)

Conclusions

This article provides a comprehensive review of low emissions combustion technologies for modern aero gas turbines. The review considers current high Technologies Readiness Level (TRL) technologies including Rich-Burn Quick-quench Lean-burn (RQL), Double Annular Combustor (DAC), Twin Annular Premixing Swirler combustors (TAPS), Lean Direct Injection (LDI). It further reviews some of the advanced technologies at lower TRL. These include NASA multi-point LDI, Lean Premixed Prevaporised (LPP), Axially Staged Combustors (ASC) and Variable Geometry Combustors (VGC).

The focus of review is placed on working principles, a review of the key technologies (includes the key technology features, methods of realising the technology, associated technology advantages and design challenges, progress in development), technology application and emissions mitigation potential. The article concludes the technology review by providing a technology evaluation matrix based on a number of combustion performance criteria including altitude relight auto-ignition flashback, combustion stability, combustion efficiency, pressure loss, size and weight, liner life and exit temperature distribution.

Acknowledgement

The authors would like to thank the AECC Hunan Aviation Power Machinery Research Institute for funding the research. The technical advice provided by Mr. Bryn Jones and Dr Pierre Gauthier is gratefully appreciated. The authors are also very grateful to Miss Yingyi Liu, Dr. Eric M Goodger and Prof Max Platzer for providing support with proof reading and editing the paper.

References

- [1] International Civil Aviation Organization (ICAO). ICAO. Annex 16 to the convention on international civil aviation, environmental protection, volume II, aircraft engine emissions. 3rd edition. Technical report, ICAO, 2008.
- [2] Environment Branch of the International Civil Aviation Organization (ICAO). ICAO environmental report 2013. Technical report, ICAO, 2013.
- [3] N Dickson. Local air quality and ICAO engine emissions standards, Available at: http://www.icao.int/Meetings/EnvironmentalWorkshops/Documents/2014-Kenya/4-1_LAQ_Technology_notes.pdf 2014.
- [4] Environment Branch of the International Civil Aviation Organization (ICAO). ICAO environmental report 2016. Technical report, ICAO, 2016
- [5] V. Sethi. Overview of gas turbine generated pollutants combustor, MSc Gas Turbine Combustion lecture notes, Cranfield University, 2017
- [6] M Prather, R Sausen, AS Grossman, JM Haywood, D Rind, and BH Subbaraya. Potential climate change from aviation. Aviation and the Global Atmosphere. A Special Report of IPCC Working Groups I and III. Cambridge University Press, Cambridge, UK, pages 185–215, 1999
- [7] T.C. Lieuwen and V. Yang. Gas Turbine Emissions. Cambridge Aerospace Series. Cambridge University Press, 2013.
- [8] P Glarborg, AD Jensen, and J E Johnsson. Fuel nitrogen conversion in solid fuel fired systems. Progress in Energy and Combustion Science, 29(2):89–113, 2003.
- [9] A.H. Lefebvre and D.R. Ballal. Gas Turbine Combustion: Alternative Fuels and Emissions, Third Edition. Taylor & Francis, 2010.
- [10] HC Mongia. TAPS: A fourth generation propulsion combustor technology for low emissions. AIAA International Air and Space Symposium and Exposition: The Next 100 Years, International Air and Space Symposium, 2003
- [11] R ,Roberts,, A. Peduzzi,, and G. E. Vitti,,"Experimental Clean Combustor Program Phase I Final Report", NASA CR-134736, October 1975.
- [12] T. W. Bruce,, F. G. Davis,, T. E Kuhn,, and H. C. Mongia,, 1977, "Pollution Reduction Technology Program Small Jet Engines Phase I Final Report", NASA CR-135214.
- [13] D. W Bahr,, and C. C. Gleason,, "Experimental Clean Combustor Program Phase I Final Report",
- [14] R. D. Anderson, et al, "Pollution Reduction Technology Program Turbo Prop Engines Phase I Final Report", NASA CR-135040, March 1976.
- [15] H. C., Mongia, and W. G. A. E. Dodds. "Low emissions propulsion engine combustor technology evolution past, present and future." 24th Congress of International Council of the Aeronautical Sciences, Yokohama, Japan, Aug. 2004.
- [16] ICAO, Independent Experts NOx Review and the Establishment of Medium and Long Term Technology Goals for NOx (Doc 9887) 2006

- [17] ACARE. Advisory council for aviation research and innovation in Europe activity summary 2014
- [18] https://www.nasa.gov/pdf/395949main_collier.pdf, 2014
- [19] A Giusti Development of numerical tools for the analysis of advanced airblast injection systems for lean burn aero-engine combustors, PhD thesis, University of Florence., 2013
- [20] G. S., Samuelsen, et al. "Experimental and modeling investigation of the effect of air preheat on the formation of NO_x in an RQL combustor." *Heat and Mass Transfer* 49.2 219-231. 2013
- [21] SA, Mosier RM Pierce (1980) Advanced combustor systems for stationary gas turbine engines, phase I. Review and preliminary evaluation, vol I, contract 68-02-2136, FR-11405, Final Report, U.S. Environmental Protection Agency, March
- [22], G. J Sturgess., R. McKinney, and S. Morford. "Modification of combustor stoichiometry distribution for reduced NO_x emission from aircraft engines." ASME 1992 International Gas Turbine and Aeroengine Congress and Exposition. American Society of Mechanical Engineers.
- [23] Schweitzer, K Jeffrey., et al. "Validation of propulsion technologies and new engine concepts in a joint technology demonstrator program." XVII ISABE 1002 (2005).
- [24] Haselbach, Frank, and Ric Parker. "Hot End technology for advanced, low emission large civil aircraft engines." 28th International Congress of the Aeronautical Sciences. Vol. 2. 2012.
- [25] H C Mongia. Future trends in commercial aviation engines combustion. In *Novel Combustion Concepts for Sustainable Energy Development*, pages 113-176. Springer, 2014.
- [26] M J Foust, D Thomsen, R Stickles, C Cooper, and W Dodds. Development of the GE aviation low emissions taps combustor for next generation aircraft engines. AIAA Paper, 936:2012, 2012.
- [27] G Randal McKinney, D Sepulveda, W Sowa, and A Cheung. The pratt & whitney Talon X low emissions combustor: revolutionary results with evolutionary technology. In 45th AIAA Aerospace Sciences Meeting and Exhibit, page 386, 2007.
- [28] J. M. Cohen and T. J. Rosfjord "Influences on the Sprays Formed by High-Shear Fuel Nozzle/Swirler Assemblies"; *Journal of Propulsion and Power*, Vol. 9, no 1. January 1993.
- [29] H Mongia. "Engineering Aspects of Complex Gas Turbine Combustion Mixers Part IV: Swirl cup", 9th Annual International Energy Conversion Engineering Conference, 2011
- [30] H Mongia,. "On continuous NO_x reduction of aero-propulsion engines." 48th AIAA Aerospace Sciences Meeting Including the New Horizons Forum and Aerospace Exposition. 2010.
- [31] Holdeman, James D., James R. Clisset, and Jeffrey P. Moder. "Spreadsheet calculations for jets in crossflow: opposed rows of inline and staggered holes and single and opposed rows with alternating hole sizes." (2010).
- [32] Holdeman, James D., James R. Clisset, and Jeffrey P. Moder. "Spreadsheet calculations of jets in crossflow: opposed rows of inline and staggered round holes." *Heat and Mass Transfer* 48.2 413-424. (2012):
- [33] Holdeman, James D., et al. "On the mixing of single and opposed rows of jets with a confined crossflow." (2006).
- [34] Margason, Richard J. "Fifty years of jet in cross flow research." In AGARD, *Computational and Experimental Assessment of Jets in Cross Flow* 41 p (SEE N94-28003 07-34). Vol. 1. 1993.

- [35] Holdeman, James D., David S. Liscinsky, and Daniel B. Bain. "Mixing of multiple jets with a confined subsonic crossflow: Part II—Opposed rows of orifices in rectangular ducts." ASME 1997 International Gas Turbine and Aeroengine Congress and Exhibition. American Society of Mechanical Engineers, 1997.
- [36] Holdeman, James D., et al. "Mixing of multiple jets with a confined subsonic crossflow in a cylindrical duct." ASME 1996 International Gas Turbine and Aeroengine Congress and Exhibition. American Society of Mechanical Engineers, 1996.
- [37] Holderman, J. D., et al. "A spreadsheet for the mixing of a row of jets with a confined crossflow." (2005).
- [38] Sridhara, K., "Gas Mixing in the Dilution Zone of a Combustion Chamber," College of Aeronautics MSc thesis 20/187, Cranfield, UK
- [39] Cooling patches to reduce gas and wall temperature levels and gradients; Source: US Patent Application 2008/0010991 A1 Jan. 17, 2008.
- [40] FP7 Coordination Action – GA 605506 , 2014
- [41] Malecki, Robert E., et al. "Application of an Advanced CFD-Based Analysis System to the PW6000 Combustor to Optimize Exit Temperature Distribution: Part I—Description and Validation of the Analysis Tool." ASME Turbo Expo 2001: Power for Land, Sea, and Air. American Society of Mechanical Engineers, 2001.
- [42] Snyder, Timothy S., et al. "Application of an Advanced CFD-Based Analysis System to the PW6000 Combustor to Optimize Exit Temperature Distribution: Part II—Comparison of Predictions to Full Annular Rig Test Data." ASME Turbo Expo 2001: Power for Land, Sea, and Air. American Society of Mechanical Engineers, 2001.
- [43] Lee, Chi-Ming. "NASA project develops next generation low-emissions combustor technologies." 51st AIAA Aerospace Sciences Meeting including the New Horizons Forum and Aerospace Exposition. 2013.
- [44] J Moran. Engine technology development to address local air quality concerns, May 2007.
- [45] G Randal McKinney, D Sepulveda, W Sowa, and A Cheung. The pratt & whitney Talon X low emissions combustor: revolutionary results with evolutionary technology. In 45th AIAA Aerospace Sciences Meeting and Exhibit, page 386, 2007.
- [46] M. Ralph P. Kuentzmann, L. Maurice and J. Tilston. Report of the independent experts to CAEP/8 on the second nox review and the establishment of medium and long term technology goals for nox. Technical Report Doc 9953, ICAO, 2010.
- [47] R Smith. Advanced low emissions subsonic combustor study. 1998. (Final Report), Lewis Research Centre, NASA/CR--1998-207931
- [48] P Glarborg, AD Jensen, and J E Johnsson. Fuel nitrogen conversion in solid fuel fired systems. Progress in Energy and Combustion Science, 29(2):89–113, 2003.
- [49] FJ Martin and PK Dederick. No x from fuel nitrogen in two-stage combustion. In Symposium (International) on Combustion, volume 16, pages 191–198. Elsevier, 1977.
- [50] HC. Mongia GE Aviation Low Emissions Combustion Technology Evolution available at: http://www.iitk.ac.in/comb/Comb_15/Old%20Websites/backup/PDF/Hukam%20C.%20Mongia.pdf Accessed: 03/02/2017

- [51] DW Bahr, CC Gleason (1973) Experimental clean combustor program, phase I—final report. NASA CR-134737
- [52] A Klein, "Characteristics of Combustor Diffusers," *Progress in Aerospace Science*, Vol. 31, pp. 171–271, 1995.
- [53] P. E. Sabla, Taylor, J. R., and Gaunter, D. J., "Design and Development of the Combustor Diffuser for NASA/GE Energy Efficient Engine," *Journal of Energy*, Vol. 6, pp. 275–82, 1982.
- [54] D. L. Burrus, et al., "Energy Efficient Engine Combustion System Component Technology Performance Report", NASA CR-168274, July 1984
- [55] H C Mongia, "N+ 3 and N+ 4 Generation Aeropropulsion Engine Combustors: Part 3: Small Engine Emissions and Axial Staging Combustion Technology." GT2013-94572, *ibid*, (2013).
- [56] M. Daly. *Janes aero-engines: 2014-2015*. Janes Information Group, March 2014.
- [57] ICAO Aircraft Engine Emissions Databank. Aircraft engine emissions v22, 2016.
- [58] Mongia, N+3 AND N+4 generation aeropropulsion engine combustors: PART 2: medium size-rich dome engines and lean-domes, ASME TURBO EXPO 2013
- [59] He, Zhuohui J., et al. "Emission Characteristics of A P&W Axially Staged Sector Combustor." 54th AIAA Aerospace Sciences Meeting. 2016.
- [60] He, Zhuohui J. "NO_x Emissions Characteristics and Correlation Equations of Two P and W% 27s Axially Staged Sector Combustors Developed Under NASA Environmentally Responsible Aviation% 28ERA% 29 Project." (2017).
- [61] M J Foust, D Thomsen, R Stickles, C Cooper, and W Dodds. Development of the ge aviation low emissions taps combustor for next generation aircraft engines. AIAA Paper, 936:2012, 2012.
- [62] HS Hura, et al. Fuel nozzle assembly for reduced exhaust emissions US Patent 6,389,815 May 21, 2002
- [63] Foust, Michael, "GE Aviation Low Emissions Combustion Technologies," Presentation made at ASME IGTI Turbo Expo 2010 Glasgow, Scotland, June 15, 2010
- [64] Jinhu, L. Su, W. Honghao, H. Shengtao, Zh. Bingcheng, F. and Jiping, C., "Shock tube study of kerosene ignition delay at high pressures", *Phys. Mech. Astron.*, 55 (6), 947 (2012)
- [65] Zhukov, V. P. Sechenov, V. A. and Starikovskiy, A. Y., "Autoignition of kerosene (Jet-A)/air mixtures behind reflected shock waves", *Fuel*, 126, 169 (2014).
- [66] F. S. Shariatmadar, S. Ghanbari Pakdehi*, M. A. Zarei "An Empirical Correlation to Predict the Ignition Delay Time for Some Hydrocarbon Fuels" *Iranian Journal of Chemical Engineering* Vol. 13, No. 1, IACHE 2016
- [67] C Guin. Characterisation of autoignition and flashback in premixed injection systems. In RTO Meeting proceedings, 1999.
- [68] Mongia, Hukam. "Engineering Aspects of Complex Gas Turbine Combustion Mixers Part V: 40 OPR" 49th AIAA Aerospace Sciences Meeting including the New Horizons Forum and Aerospace Exposition. 2011.
- [69] Y. Huang, V. Yang, Bifurcation of flame structure in a lean-premixed swirl-stabilized combustor: transition from stable to unstable flame *Combustion and Flame* 136 383–389. (2004)

- [70] Dhanuka, Sulabh K., Jacob E. Temme, and James Driscoll. "Unsteady aspects of lean premixed prevaporized gas turbine combustors: flame-flame interactions." *Journal of Propulsion and Power* 27.3 (2011): 631-641.
- [71] Multi-swirler mixers with plasma generating nozzle US patent 6455660.
- [72] http://www.geaviation.com/press/ge90/ge90_20141120.html accessed on 10/03/2017
- [73] Reddy, Dhanireddy R., and Chi-Ming Lee. "An Overview of Low-Emission Combustion Research at NASA Glenn." *ASME Turbo Expo 2016: Turbomachinery Technical Conference and Exposition*. American Society of Mechanical Engineers, 2016.
- [74] J Shaw, and C Peddie., 'UEET NASA Ultra Efficient Engine Technology Project Overview, Enabling Technologies for 21st Century Turbine Engines', NASA/CP-2004-212963/VOL1,Sep 2003
- [75] R Stickles. TAPS II combustor final report. Technical Report DTFAWA-10-C-00046, General Electric, June 2013.
- [76] J Croft. Engine buzz: blisks, sabers and safran. *Flight International*, 178(5263):22, 2010.
- [77] D A Nickolaus, D S Crocker, D L Black, and C E Smith. Development of a lean direct fuel injector for low emission aero gas turbines. In *ASME Turbo Expo 2002:Power for Land, Sea, and Air*, pages 713–720. American Society of Mechanical Engineers,2002.
- [78] W. Lazik, T Doerr, and S Bake. 'Low NOx Combustor development for the Engine 3E Core Engine Demonstrator.' IASBE-2007-1190, 2007
- [79] R Bank, S Donnerhack, A Rae, M Cazalens, A Lundblad, and M Dietz. LEMCOTEC: Improving the core-engine thermal efficiency In *ASME Turbo Expo 2014*.
- [80] C E Smith, D A Nickolaus. Piloted airblast lean direct fuel injector with modified air splitter: U.S. Patent 6,986,255. 2006-1-17.
- [81] D S Crocker, D A Nickolaus, C E Smith. Piloted airblast lean direct fuel injector: U.S. Patent 6,272,840. 2001-8-14.
- [82] D S Crocker, D L Black. Single-circuit fuel injector for gas turbine combustors: U.S. Patent 6,543,235[P]. 2003-4-8.
- [83] NEWAC, NEWAC Technologies Highly Innovative Technologies for Future Aero Engines., 2011
- [84] Robert Tacina, Chien-Pei Mao, and Changlie Wey. Experimental investigation of a multiplex fuel injector module with discrete jet swirlers for low emission combustors. *AIAA Paper*, 135, 2004.
- [85] R Tacina, C Wey, P Laing, A Mansour.: A low-NOx Lean-Direct Injection, multiPoint integrated module combustor concept for advanced aircraft gas turbines. *NASA/TM-2002-211347*,2002
- [86] R Tacina, C P Mao, C Wey, Experimental investigation of a multiplex fuel injector module for low emissions combustors. *AIAA-2003-0827*, 2003.
- [87] R Tacina P Lee, C Wey. A Lean-Direct-Injection combustor using a 9 point swirl-venturi fuel injector. *ISABE-2005-1106*, 2005.
- [88] M K Tacina and C Wey. NASA Glenn high pressure low Nox emissions research *NASA/TM—2008-214974*, 2008.

- [89] B Jones, Attempts to reduce NOx: gas turbine short course lecture series, Cranfield University June 2016.
- [90] C T Chang, C M Lee, J T Herbon and S K Kramer, NASA Environmentally Responsible Aviation Project Develops Next- Generation Low-Emissions Combustor Technologies (Phase I), Aeronautics & Aerospace Engineering, 2013.
- [91] KM Tacina, CT Chang, ZJ He, P Lee, B Dam, H Mongia A second generation swirl-venturi lean direct injection combustion concept. AIAA paper 2014-3434, 2014
- [92] Ajmani K, Mongia HC, Lee P (2013a) Evaluation of CFD best practices for combustor design: part I— non-reacting flows. AIAA paper 2013-1144
- [93] Ajmani K, Mongia H, Lee P (2014) CFD computations of emissions for LDI-2 combustors with simplex and air blast injectors. AIAA paper 2014-3529
- [94] Tacina KM, Chang CT, He ZJ, et al.. A second generation swirl-venturi Lean Direct Injection combustion concept. 50th AIAA/ASME/SAE/ASEE Joint Propulsion Conference, 2014.
- [95] Goeke J, Pack S, Zink G, Ryon J. NASA/CR—2014-218112: Multi-point combustion system final report. 2014.
- [96] Ajmani K, Breisacher K (2014) Simulations of NOx emissions from low emissions discrete jet injector combustor tests. AIAA paper 2014-3524
- [97] Ajmani K, Mongia HC, Lee P (2013b) CFD best practices to predict NOx, CO and lean blowout for combustor design. GT2013-9566
- [98] Ajmani K, Mongia HC, Lee P (2013c) Evaluation of a time-filtered Navier stokes (TFNS) CFD approach for LDI combustor analysis. AIAA paper 2013-3688
- [99] ZJ He, CT Chang, CE Follen. NOx emissions performance and correlation equations for a multipoint LDI injector. NASA/TM—2014-218116, April 2014
- [100] G Leonard,. and J Stegmaier,. Development of an Aero-derivative Gas Turbine Dry Low Emissions Combustion System ,J.Eng. Gas Turbine Power, V 116, issue 3, 542, July 1994.
- [101] S. L Plee,, and A. M Mellor, Review of Flashback Reported in Pre-vaporizing/Premixing Combustors.” Comb. and Flame 32: 193–203, 1978
- [102] Z, J Fritz, M, Kröner, and T. Sattelmayer, Flashback in a Swirl Burner with Cylindrical Premixing Zone. Journal of Engineering for Gas Turbines and Power 126(2): 276–83., 2004
- [103] H. Pervier, Emissions Modelling for Engine Cycle and Aircraft Trajectory Optimisation, PhD thesis, Cranfield University ,2013
- [104] C.C Gleason D.W. Bahr Experimental clean combustor program, phase I final report -GE. Technical Report NASA-CR-134737, General Electric Company
- [105] S.C.Greenfield, P.V Heberling, J Kastl ,J Matulaitis, and ,C Huff.. HSCT Sector Combustor Evaluations for Demonstration Engine. NASA/CR-2004-213132, 2004
- [106] P&W and GE, Critical Propulsion Components, NASA/CR—2005-213584
- [107] S Colantuoni. Sub-project 6 innovative combustor, June 2009. Available at: http://www.newac.eu/uploads/media/NEWAC_Warsaw_Workshop_SP6_presentation_01.pdf

- [108] ARTTIC,NEWAC Publishable Final Activity Report, NEWAC - FP6-030876.,2011
- [109] G Wilfert, J Sieber, A Rolt, N Baker, A Touyeras, S Colantuoni. New environment friendly aero engine core concepts.: ISABE-2007-1120. 2007
- [110] S Colantuoni. Bake, and J. P. Badet. "Low emissions combustors development for new aero-engines core applications." 5th European Congress on Computational Methods in Applied Sciences and Engineering, ECCOMAS. 2008.
- [111] G. J. Micklow, S. Roychoudhury, H. L. Nguyen and M. C. Cline: Emissions Reduction by Varying the Swirler Airflow Split in Advanced Gas Turbine Combustors: Journal of Engineering for Gas Turbines and Power, Vol. 115 July 1993
- [112] Donald F. Schultz, Variable Combustor Geometry for improving the altitude relight capability of A double annular combustor, NASA TM X-3163, 1975
- [113] YG. Li and R. L. Hales Gas Turbine Emissions Control Using Variable Geometry Combustor and Fuel Staging, AIAA 2002-0079
- [114] Li, Y. G., and R. L. Hales. "Steady and dynamic performance and emissions of a variable geometry combustor in a gas turbine engine." ASME Turbo Expo 2002: Power for Land, Sea, and Air. American Society of Mechanical Engineers, 2002.
- [115] K Aoyama, and S. Mandai, "Development of a Dry Low NOx Combustor for a120 MW Gas Turbine," Journal of Engineering for Gas Turbines and Power, Vol. 106, pp. 795–800, 1984.
- [116] A. Wulff, J. Hourmouziadis, Technology Review of Aeroengine Pollutant Emissions, Aerospace Science and Technology
- [117] R.S Fletcher. and R.C Adkins., "The Variable Geometry Combustor", AGARD Conference (48 PEP Meeting), Paris, September
- [118] S Hayashi., H Yamada. and K Shimodaira., "Engine Testing of a Natural Gas-Fired, Low-NOx, Variable Geometry Gas Turbine Combustor for a Small Gas Turbine", ASME 96-GT-455, International Gas Turbine and Aeroengine Congress & Exhibition, Birmingham, UK, June 10-13, 1996.
- [119] D.F Schultz., "Ground Idle Performance Improvement of a Double-Annular Combustor by Using Simulated Variable Combustor Geometry", NASA TM X-3176,
- [120] D.F Schultz., "Variable Combustor Geometry for Improving the Altitude Relight Capability of a Double Annular Combustor", NASA TM X-3163,
- [121] A.K Gupta., Ramavajjala M.S. and Chomiak J., "Burner Geometry Effects on Combustion and NOx Emission Characteristics of Variable Geometry Swirl Combustor", AIAA-89-0488, 1988.
- [122] R.S. Fletcher, "The Automotive Gas Turbine", Conference on developments in automotive power plants to reduce fuel consumption, air pollution and noise",
- [123] I J Saintsbury, J.A. and, P. Sampath, "Atmospheric Tests of a Variable Combustor Geometry for Reducing Gas Turbine Emissions", ASME/CSME Conference, Monteria, Canada, May 1974

- [124] N. K Rizk, and H. C Mongia, "NO_x Model for Lean Combustion Concept," *Journal of Propulsion and Power*, Vol. 11, No. 1, pp. 161–9, 1995.
- [125] Zhao Dan, and X. Y. Li. "A review of acoustic dampers applied to combustion chambers in aerospace industry." *Progress in Aerospace Sciences* 74 (2015): 114-130.
- [126] J, Chenzhen, Zhao Dan, et al. "Parametric measurements of the effect of in-duct orifice edge shape on its noise damping performance." *Journal of Sound and Vibration* 384 (2016): 130-145.
- [127] Zhao Dan, L Ang, and C. Z. Ji. "Numerical and experimental investigation of the acoustic damping effect of single-layer perforated liners with joint bias-grazing flow." *Journal of Sound and Vibration* 342 (2015): 152-167.
- [128] V. Sethi. Lecture notes in gas turbine combustors, volume 3, Cranfield University, 2015.
- [129] A. M. Mellor. Design of modern turbine combustors. Academic Press, 1990.
- [130] P P Walsh and P Fletcher. Gas turbine performance. John Wiley & Sons, 2004.
- [131] HC. Mongia GE Aviation Low Emissions Combustion Technology Evolution Available 2014 at:
http://www.iitk.ac.in/comb/Comb_15/Old%20Websites/backup/PDF/Hukam%20C.%20Mongia.pdf
- [132] SULPHUR - Reduction of sulphur limits in aviation fuel standards EASA report 2010.
- [133] Combustor Fundamentals and Key Issues in Future Combustor Technology – The Rolls-Royce Perspective– Paris – FORUM-AE - Combustor Technology Workshop, June 2014
- [134] Paul Madden, CAEP Combustion Technology Review Process and CAEP NO_x Goals, FORUM-AE- June 2014.
- [135] Kenneth Yong, Lean Burn Technology at Rolls-Royce Paris – FORUM-AE - Combustor Technology Workshop, June 2014
- [136] S K Dhanuka, JE Temme, J F Driscoll, and H C Mongia. Vortexshedding and mixing layer effects on periodic flashback in a lean premixed prevaporized gas turbine combustor. *Proceedings of the Combustion Institute*, 32(2):2901-2908, 2009.
- [137] H Klinger, W Lazik, and T Wunderlich. The engine 3E core engine. In *ASME Turbo Expo 2008: Power for Land, Sea, and Air*, pages 93–102. American Society of Mechanical Engineers, 2008.
- [138] Jingxuan Li, Dong Yang, Charles Luzzato and Aimee S. Morgans Open Source Combustion Instability Low Order Simulator (OSCILOS{Long}) Technical report, 2015
- [139] J.R. Mahan and A. Karchemer. *Aeroacoustics of Flight Vehicles: Theory and Practice. Volume 1: Noise Sources*, volume 1, chapter Combustion and core noise, pages 483-517. WRDC Technical Report 90-3052, 1991.
- [140] S. Candel. Combustion dynamics and control: Progress and challenges. *Proceedings of the Combustion Institute*, 29(1):1-28, 2002.
- [141] S. Ducruix, T. Schuller, D. Durox, and S. Candel. Combustion dynamics and instabilities: Elementary coupling and driving mechanisms. *Journal of Propulsion and Power*, 19(5):722-734, 2003.
- [142] S.M. Correa. Power generation and aeropropulsion gas turbines: From combustion science to combustion technology. *Proceedings of the Combustion Institute*, 27(2):1793- 1807, 1998.

- [143] Method and apparatus to decrease combustor emissions, US 6,865,889, May 19, 2005
- [144] Ajmani, Kumud, Hukam C. Mongia, and Phil Lee. "Parametric Design of Injectors for LDI-3 Combustors." 51st AIAA/SAE/ASEE Joint Propulsion Conference. 2015.
- [145] Rich Wahls N+3 Technologies and Concepts Green Aviation Summit Integrated Solutions for Fuel, Noise, and Emission Reduction NASA Ames Research Center September 8-9, 2010
- [146] Liu, N. -S., Wey, C.T., and Shih, T. -H., "Time-Filtered Navier-Stokes Approach and Emulation of Turbulence-Chemistry Interaction," 51st AIAA Aerospace Sciences Meeting, Dallas TX, AIAA Paper ,2013
- [147] Liu, N.-S., Shih, T.-H. and Wey, C.T., "Numerical Simulations of Two-Phase Reacting Flow in a Single-Element Lean Direct Injection (LDI) Combustor Using NCC," NASA/TM—2011
- [148] Iannetti, A. C. and Liu, N.-S., "The effect of spray initial conditions on heat release and emissions in LDI CFD calculations" 46th AIAA Aerospace Science Meeting and Exhibit, Reno, Nevada, AIAA Paper 2008
- [149] Davoudzadeh, F., Liu, N.-S., and Moder, J.P., "Investigation of Swirling air flows Generated by Axial Swirlers in a Flame Tube," Proceedings of ASME Turbo Expo 2006, GT2006-91300, Barcelona, Spain (also NASA TM 2006
- [150] Tacina, Robert, Chien-Pei Mao, and Changlie Wey. "Experimental investigation of a multiplex fuel injector module for low emission combustors." 41st Aerospace Sciences Meeting and Exhibit. 2003.
- [151] Hicks, Y. R., Locke, R. J., Anderson, R. C., (2000). "Optical Measurement and Visualization in High-Pressure, High-Temperature, Aviation Gas turbine Combustors," NASA/TM-2000-2103
- [152] Introduction: Aviation outlook ICAO Environmental Report, 2010
- [153] BL Koff. Aircraft gas turbine emissions challenge. In ASME 1993 International Gas Turbine and Aeroengine Congress and Exposition, pages V03CT17A083–V03CT17A083. American Society of Mechanical Engineers, 1993.
- [154] <http://www.lemcotec.eu/>. Accessed: 30/12/2016.
- [155] Mongia, Hukam C. "N+ 3 and N+ 4 generation aeropropulsion engine combustors: Part 6: operating conditions, target goals and lifted jets." 49th AIAA/ASME/SAE/ASEE Joint Propulsion Conference. 2013. 3654.
- [156] Mongia, Hukam C., "Engineering Aspects of Complex Gas Turbine Combustion Mixers Part II: High T3," AIAA Paper 2011-0106, *ibid.* 2011
- [157] Snecma & Onera FORUM-AE non-CO2 mitigation solutions workshop proceedings, FP7-605506
- [158] David Abbott, Dynamics in Gas Turbine Combustors, Cranfield University, 2017.

Figures

Pollutant	Health Effect
CO – Carbon Monoxide	<ul style="list-style-type: none"> ● Cardiovascular effects, especially in those persons with heart conditions
HC – Unburned Hydrocarbons (a primary component of Volatile Organic Compounds, or VOC)	<ul style="list-style-type: none"> ● Eye and respiratory tract infection ● Headaches ● Dizziness ● Visual disorders ● Memory impairment
NO_x – Nitrogen Oxides	<ul style="list-style-type: none"> ● Lung irritation ● Lower resistance to respiratory infections
O₃ – Ozone (HC is a precursor for ground-level O ₃ formation)	<ul style="list-style-type: none"> ● Lung function impairment ● Effects on exercise performance ● Increased airway responsiveness ● Increased susceptibility to respiratory infection ● Increased hospital admissions and emergency room visits ● Pulmonary inflammation, lung structure damage
PM – Particulate Matter (smoke is a primary component of PM.)	<ul style="list-style-type: none"> ● Premature mortality ● Aggravation of respiratory and cardiovascular disease ● Changes in lung function ● Increased respiratory symptoms ● Changes to lung tissues and structure ● Altered respiratory defence mechanisms

Table 1. Main combustion pollutants and their health effect [152]

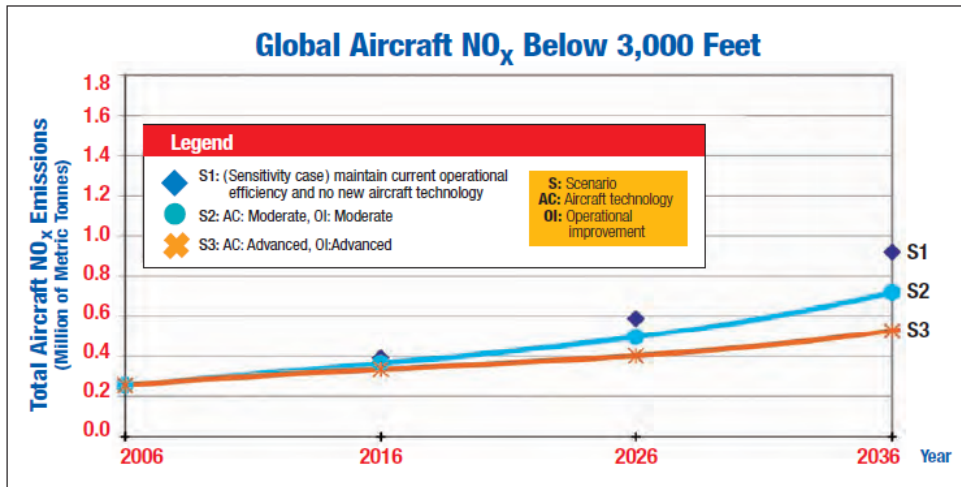

Figure 1 Global prediction of future emission trends that affect local air quality [152]

Standard	Engine OPRs	Foo kN	CO g/kN	Smoke, SN	UHC g/kN	NO _x , g/kN
CAEP/1 or ICAO 1986	All	> 26.7kN	118	$83.6 \times (Foo)^{-0.274}$	19.6	$40+2 \times OPR$

OPR=overall pressure Ratio SN=smoke number

Table 2. The first ICAO emissions standard for CO, UHC, soot and NO_x (CAEP/1) [57]

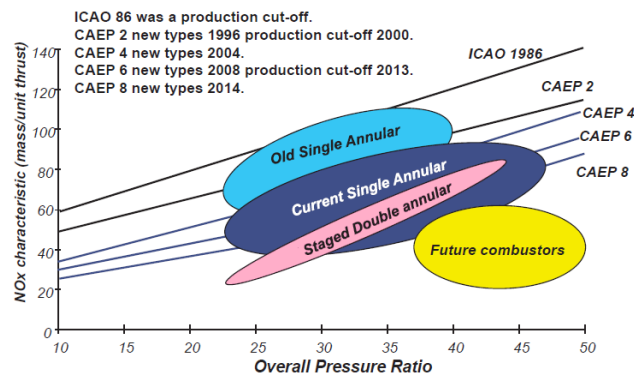

Figure 2. Evolution of Low Emissions Combustors and their NO_x emission level relative to ICAO standards [134]

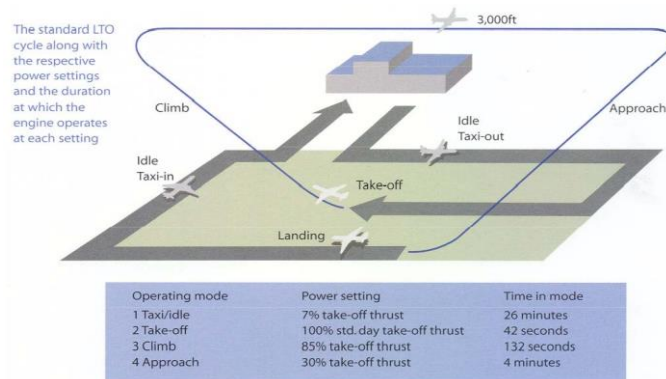

Figure 3 Illustration of ICAO landing-takeoff cycle (LTO cycle) [134]

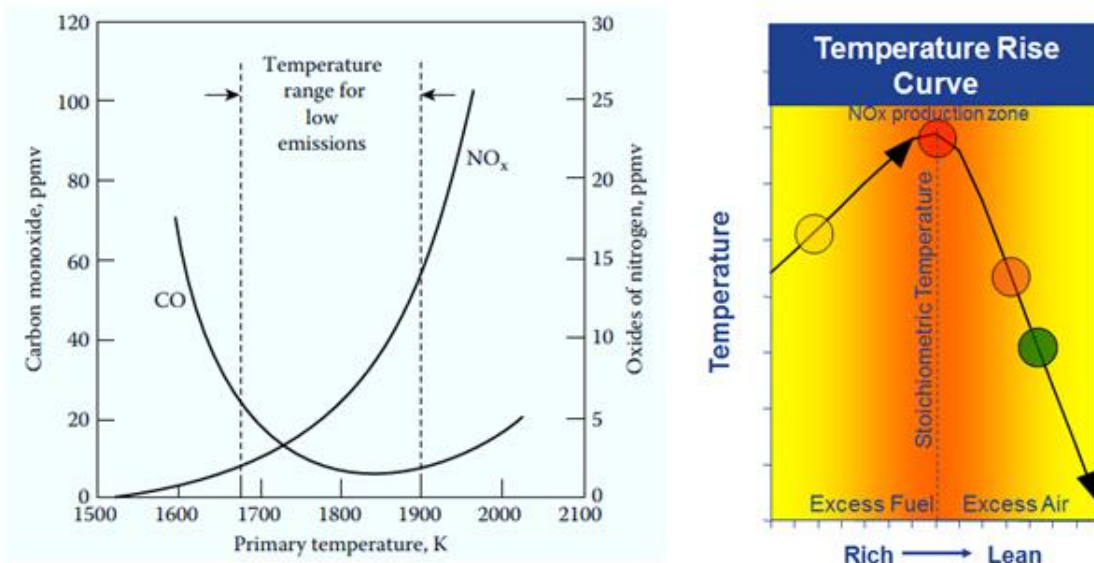

Figure 4. NO_x and CO emissions vs primary temperature and Temperature vs AFR [9]

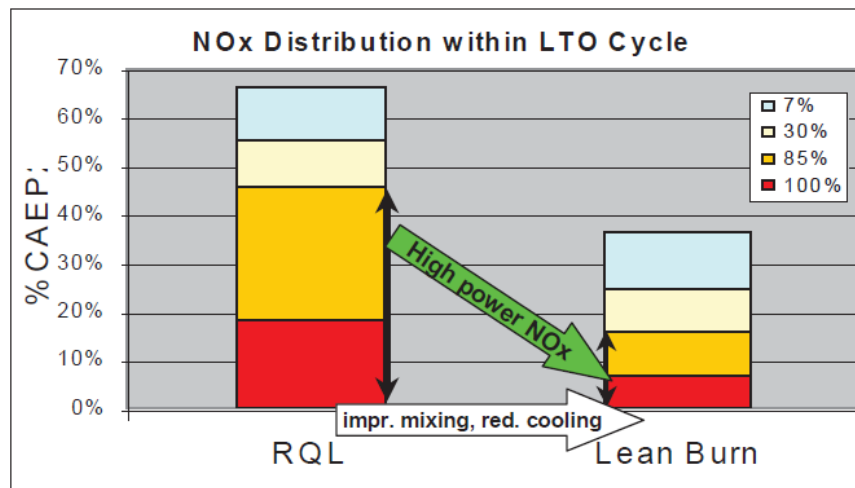

Figure 5. NO_x distribution within LTO cycle for RQL vs Lean Burn [133]

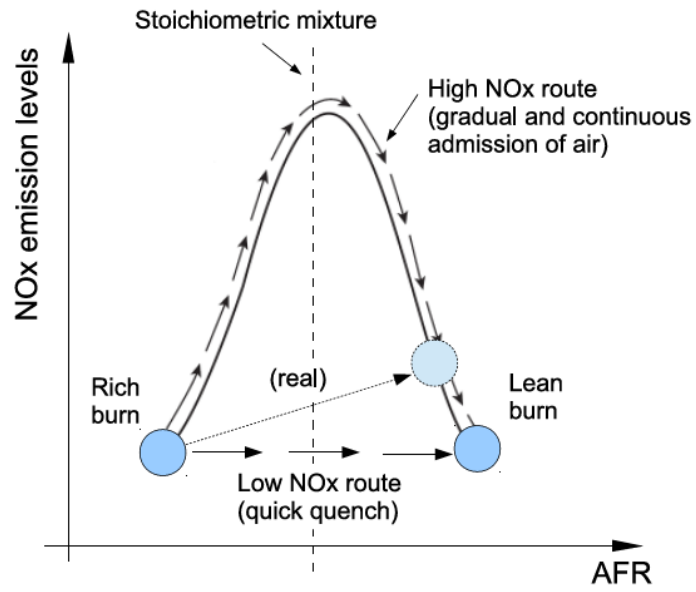

Figure 6. RQL working principle schematics and NOx formation routes [19]

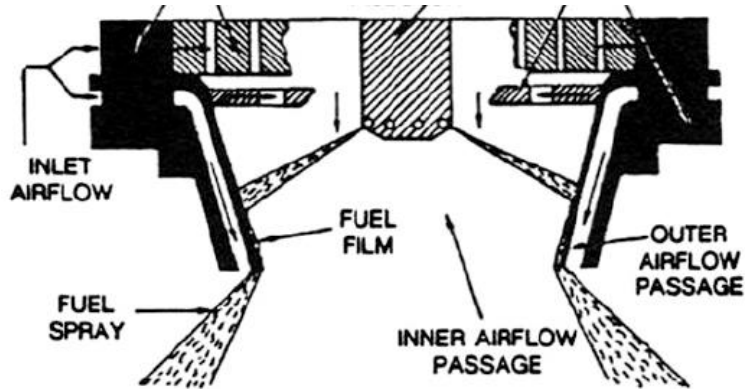

Figure 7. High shear swirl injector (TALON X) [27]

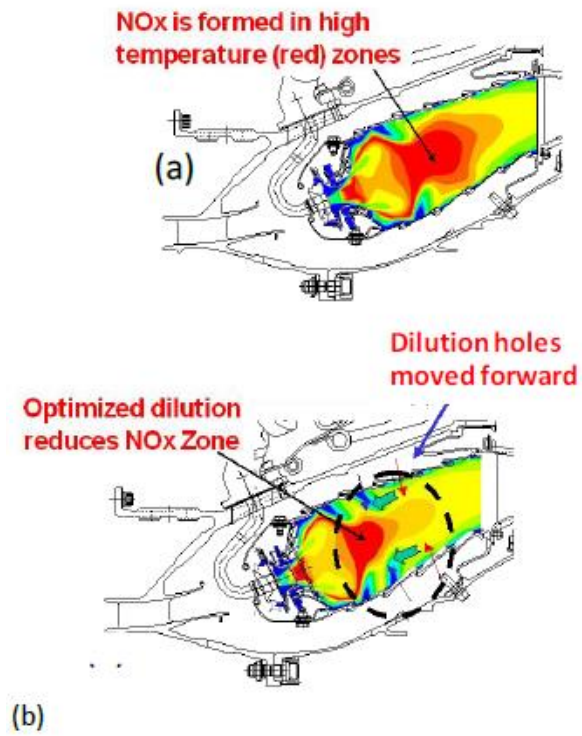

Figure 8. The effect of dilution holes moved forward on NOx reduction [30]

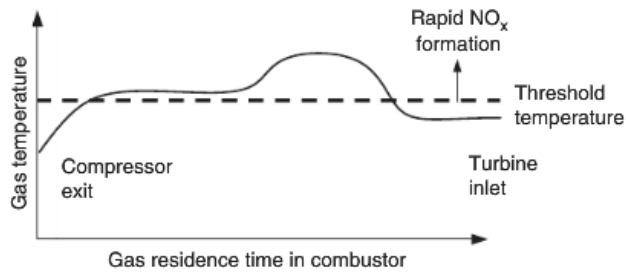

Figure 9. The axial gas temperature in a typical RQL combustor [7]

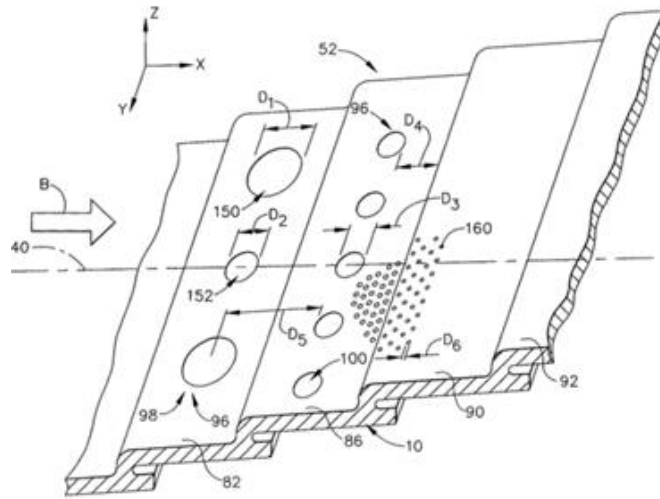

Figure 10. The local small cooling holes to reduce the wall peak temperature (US patent 2008/0010991) [39]

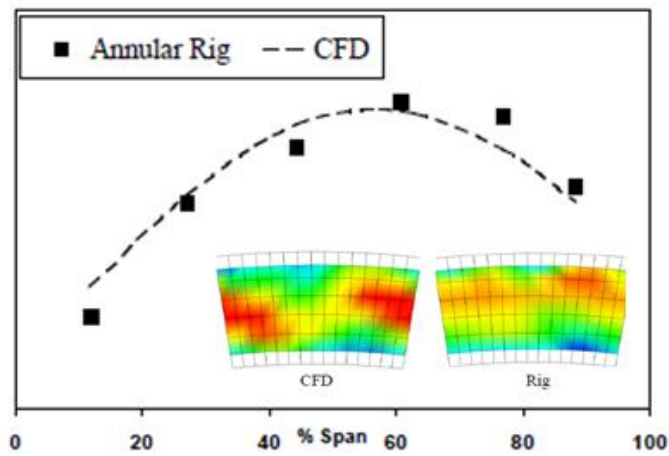

Figure 11. CFD and rig data comparison of combustor exit temperature for PW4098 RQL [41]

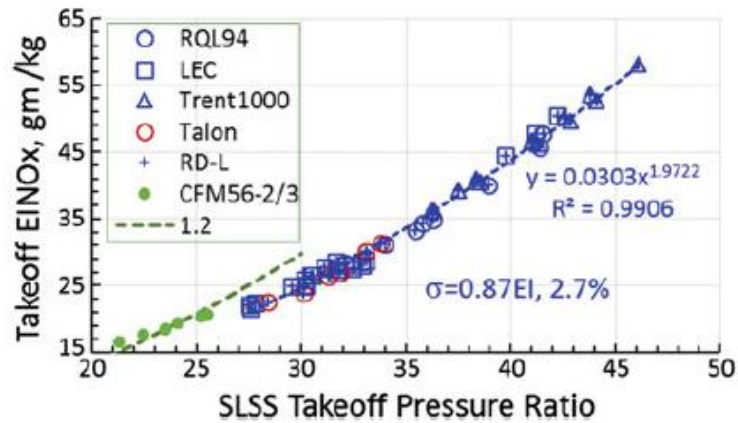

Figure 12. Take-off NO_x emissions vs engine OPR for recent RQL combustors. [25]

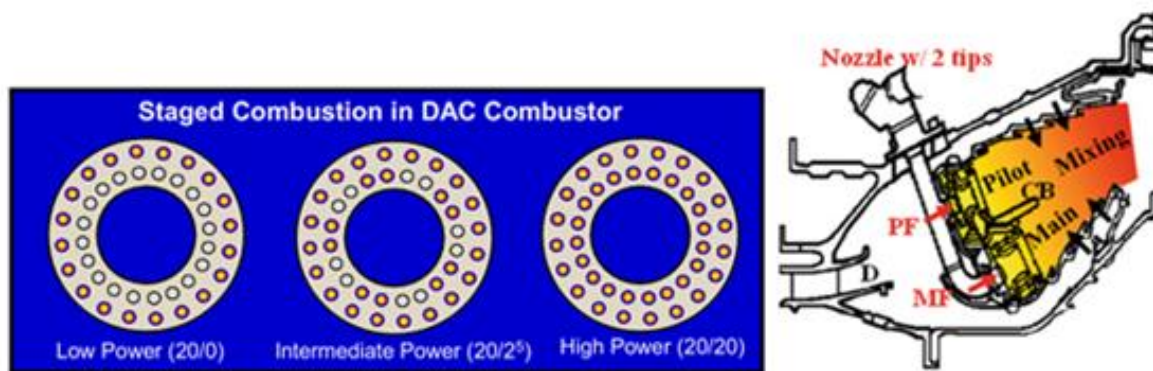

Figure 13. DAC working principles with fuel staging schemes: low power only outer annulus injectors operating, mid power outer + part of inner, full power outer+inner [50]

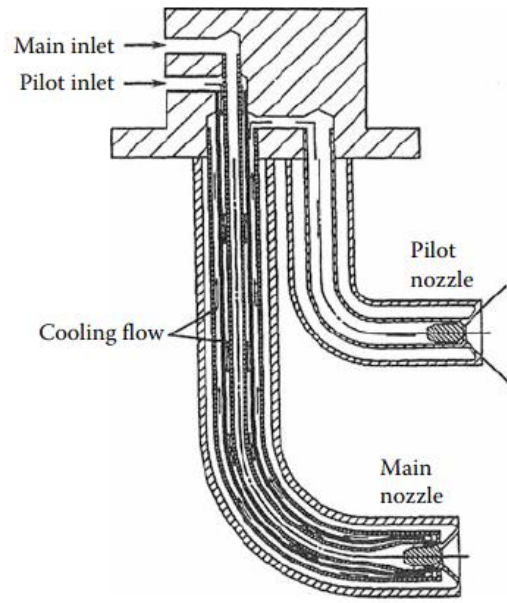

Figure 14. GE-DAC Twin-tip fuel injector with main nozzle cooled by the pilot fuel flowing around it to provide effective cooling [9]

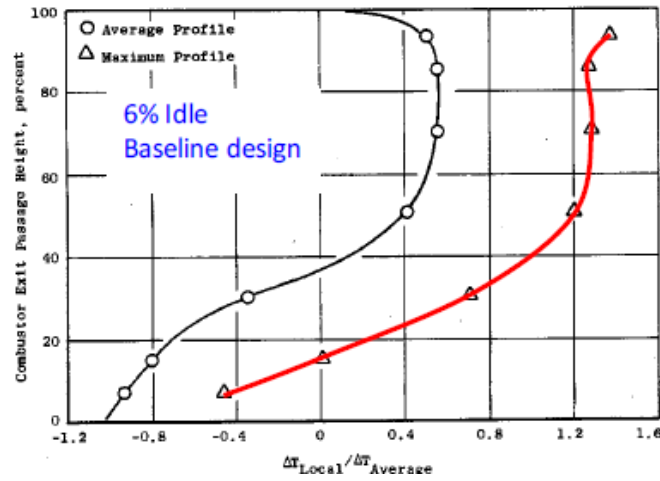

Figure 15. E3 DAC sector testing on temperature exit distribution [59]

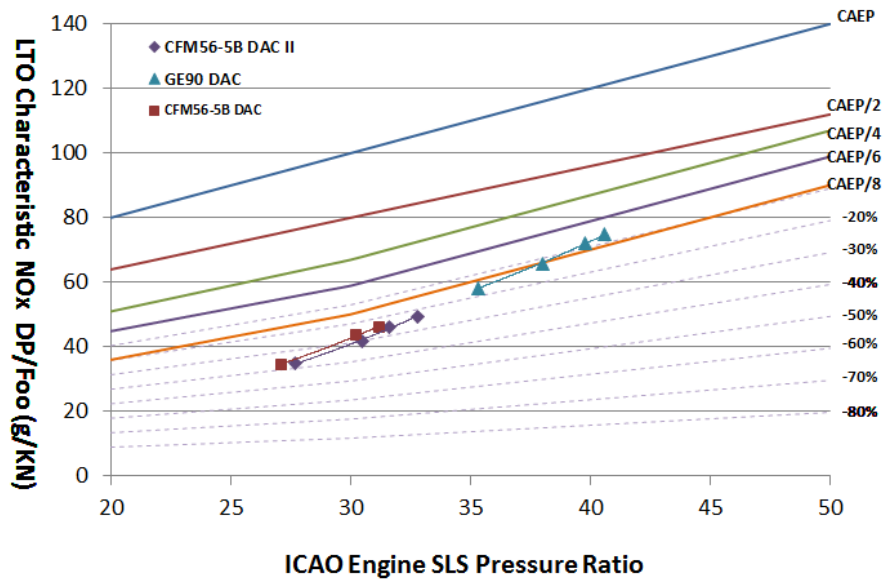

Figure16. LTO NOx vs Engine Pressure Ratio for DAC combustors (data from ICAO engine testing emission databank) [57]

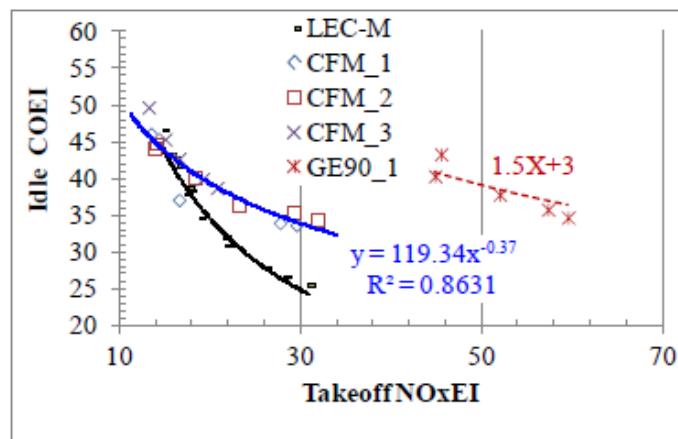

Figure 17. EI_{CO} vs EI_{NOx} for DAC combustors compared with rich burn combustors (ICAO data from engine testing and picture adapt from Mongia) [58]

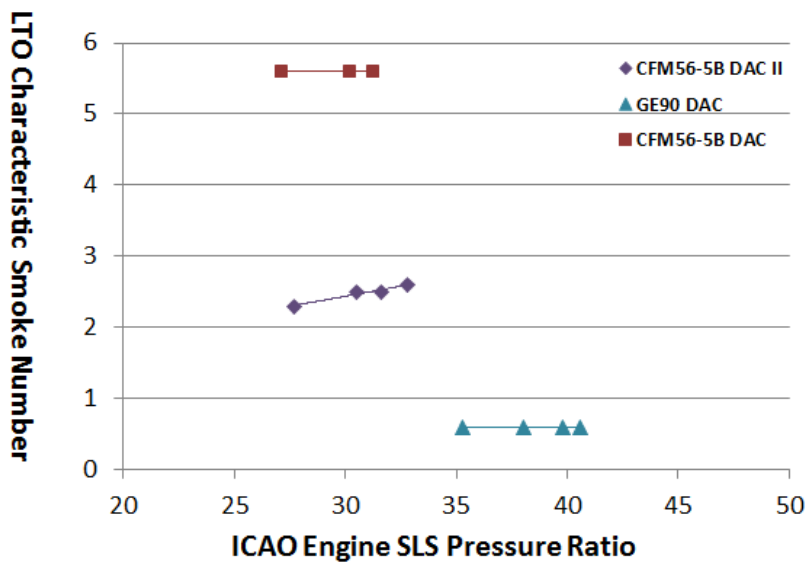

Figure 18 Smoke number vs OPR for different DAC engines and data from ICAO engine testing database [57]

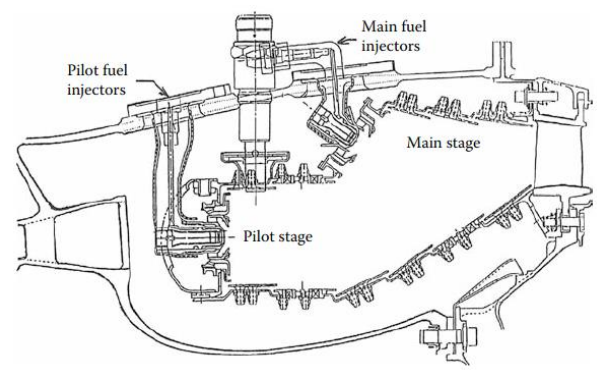

Figure 19. Pratt & Whitney V2500-A5 ASC Axial Staged Combustor [9]

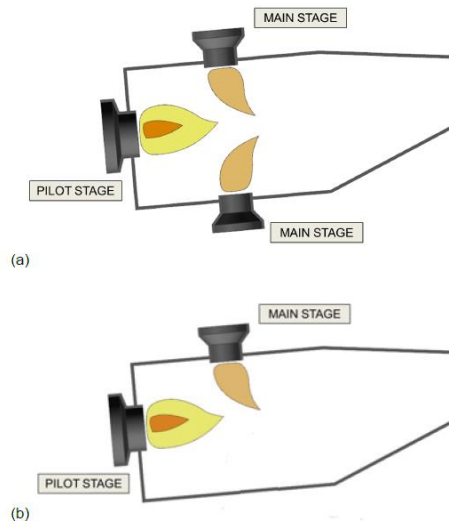

Figure 20. The new underdeveloped P&W Axially Staged Combustor Configuration Schematics with two configurations investigated [60]

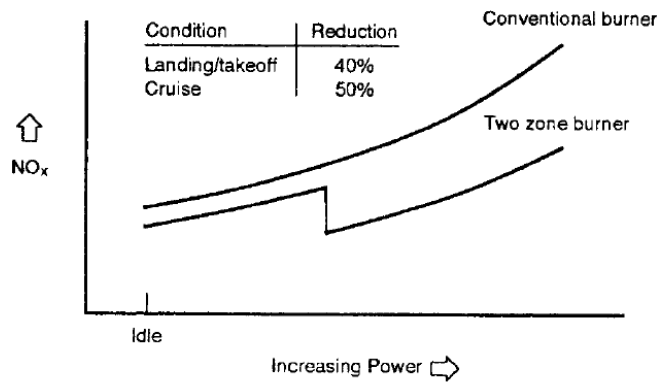

Figure 21 NO_x emissions vs power for conventional and axially staged combustors [153]

Engine Model	V2500-A5 (Baseline)	V2500 ASC (Axially staged combustor)
Pressure Ratio (EPR)	33	33
Rated Thrust (F_{oo}) kN	133.45	133.45
Bypass Ratio (BPR)	5.0	5.0
EI_{NOx} Take off (g/kg)	33.8	19.4
EI_{NOx} Climb (g/kg)	27.1	17.0
EI_{NOx} Approach(g/kg)	10.1	7.1
EI_{NOx} Idle (g/kg)	5.0	5.2
EI_{CO} Take off (g/kg)	0.45	4.4
EI_{CO} Climb (g/kg)	0.52	4.0
EI_{CO} Approach(g/kg)	1.81	11.1
EI_{CO} Idle (g/kg)	10.95	4.1

Table 3 Emissions characteristic of baseline V2500 engine and the axially staged combustor [47]

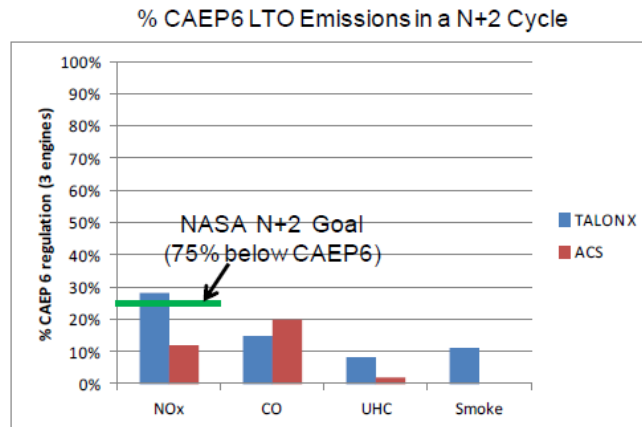

Figure 22. P&W ASC and new TALON X 3 experimental cup test results [43]

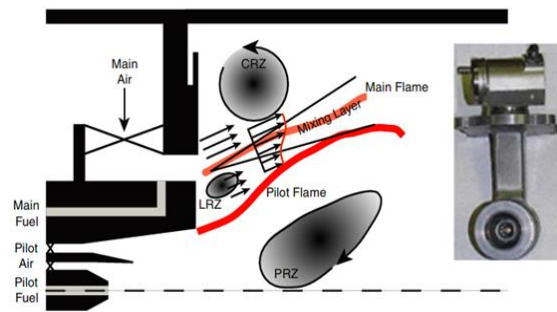

Figure 23. Schematic representation of TAPS flow and injector head (right) [136]

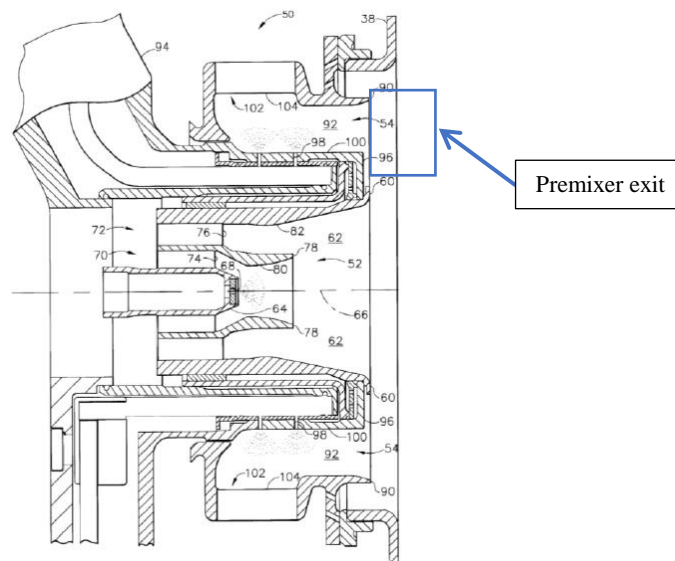

Figure 24 Fuel nozzle assembly for reduced exhaust emissions US Patent 6,389,815 May 21, 2002 [62]

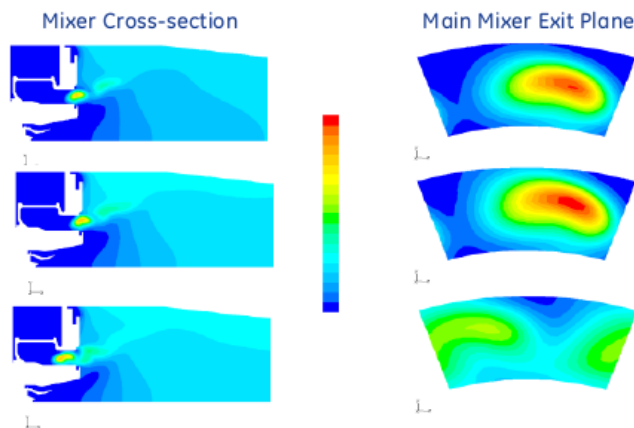

Figure 25 Equivalence ratio contour at high power of GEx TAPS main mixer design [61]

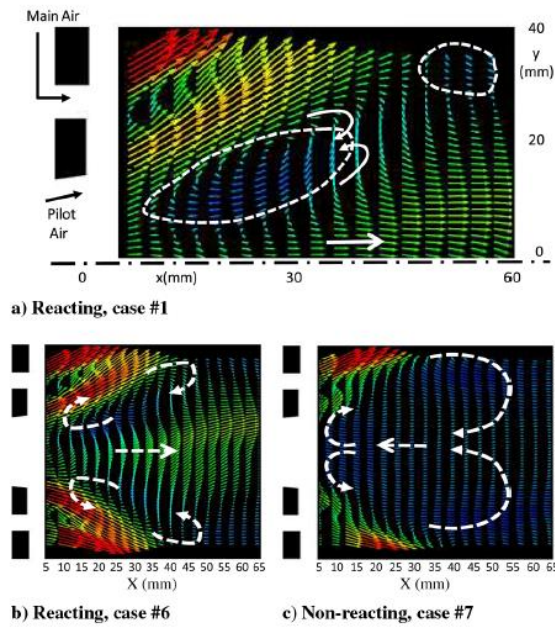

Figure 26 Mean velocity field: a) reacting, case main and pilot flames, b) reacting, pilot only preheat; and c) pilot non-reacting flow field [70]

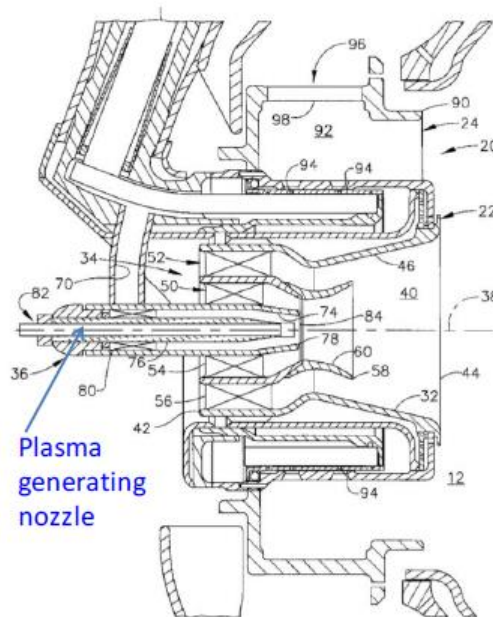

Figure 27. Multi-swirler mixers with plasma generating nozzle US patent 6455660. [71]

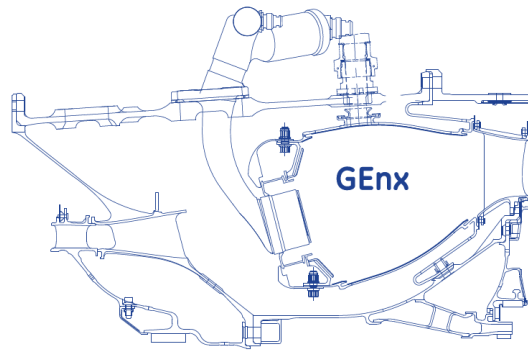

Figure 28. GEnx SAC TAPS combustor (Certified in October 2009) [61]

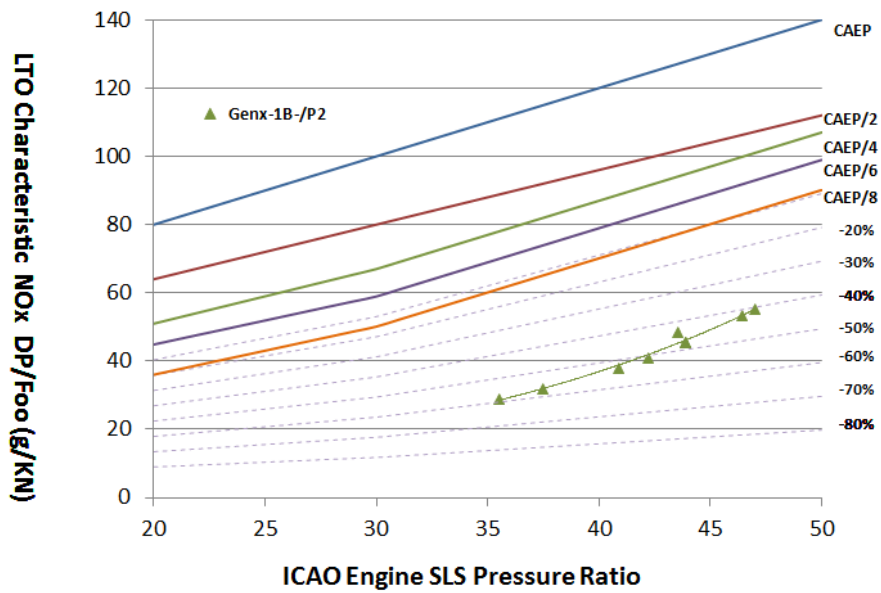

Figure 29. GEnx TAPS ICAO SLS LTO NOx emissions level (engine testing data [57])

M4F1 in the Sector				
% ICAO	Time [min]	EINO _x	dp/Foo	% CAEP/6
100	0.7	17.6	20.6	18.9
85	2.2	7.9		
30	4	13.2		
7	26	5.8		

Figure 30 GE 5-Cup experimental emissions testing results for LTO NO_x [43]

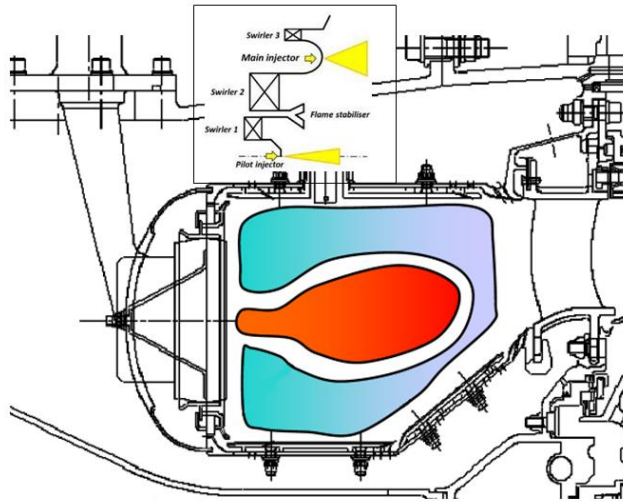

Figure 31. RR LDI combustor layout and injector schematics (Top) [19]

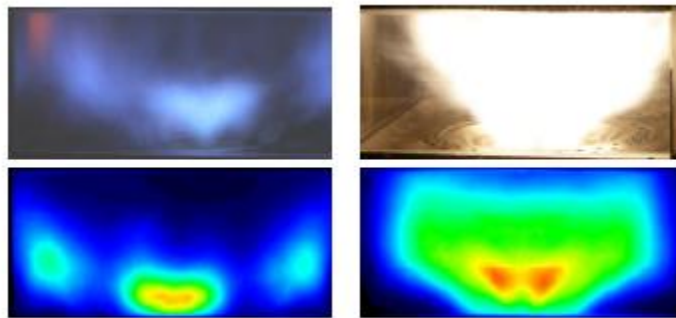

Figure 32. Flame imaging and emissions measurement for different fuel splits [78]

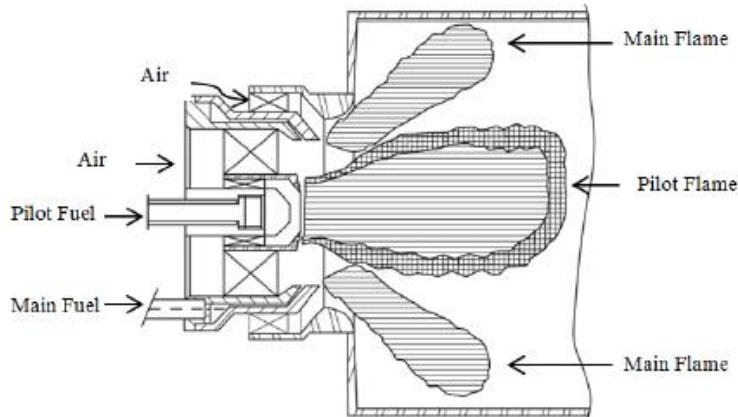

Figure 33 LDI injector head with bifurcated flow created by a splitter [US patent 6,272,840,2001 [81]]

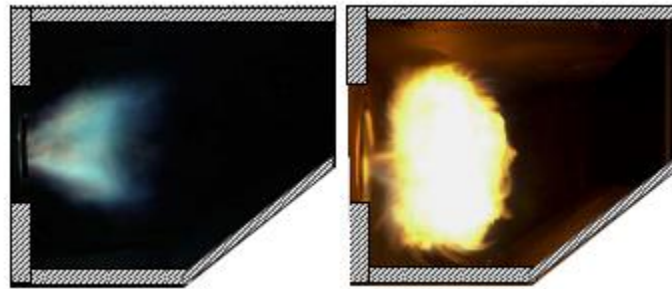

Figure 34 Pilot flames with weak (left) and strong (right) pilot swirling strength [78]

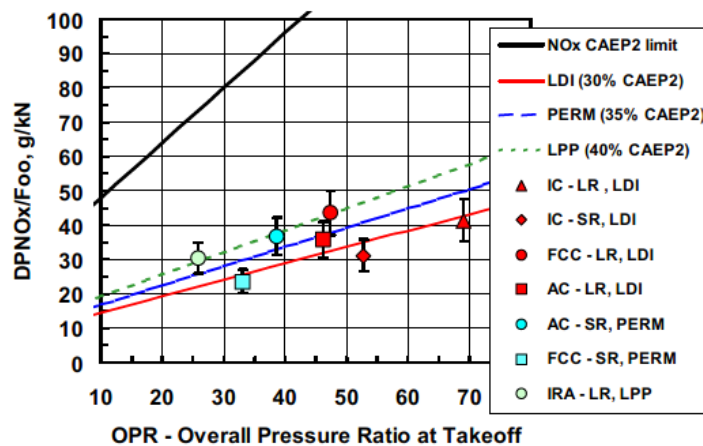

Figure 35. Experimental sector testing results for LTO NOx vs OPR for different technologies (i.e. RR LDI, PERM and LPP) [154]

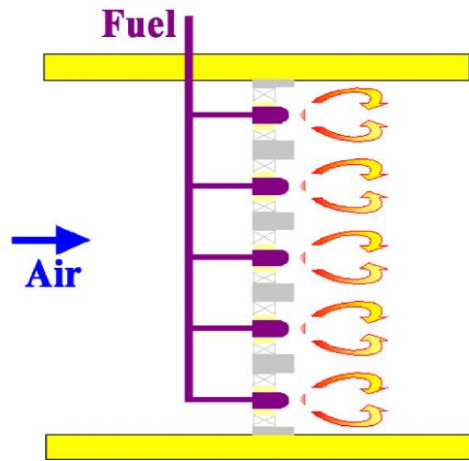

Figure 36. A Schematic of the multipoint integrated LDI module by NASA [84]

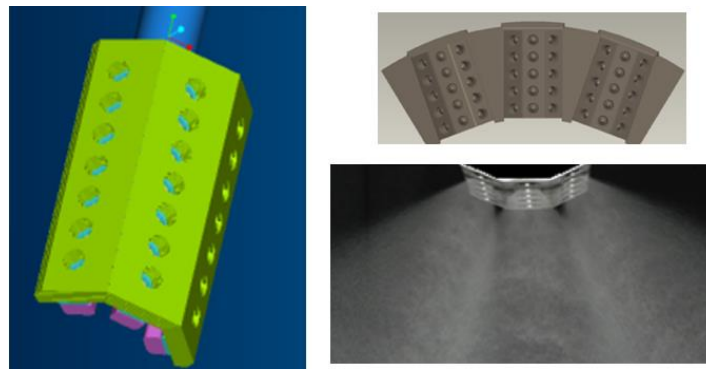

Figure 37. The 3-Zone MLDI by Parker Hannifin Corporation and spray testing (Bottom right) [90]

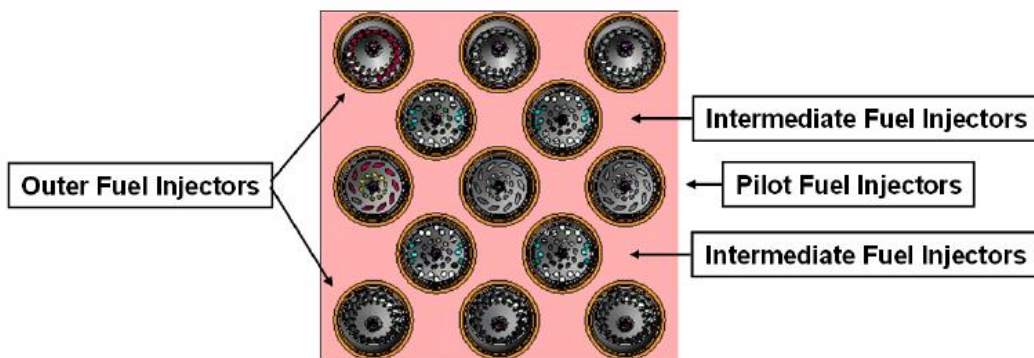

Figure 38. 5-row radially staged MLDI by Goodrich Corporation [88]

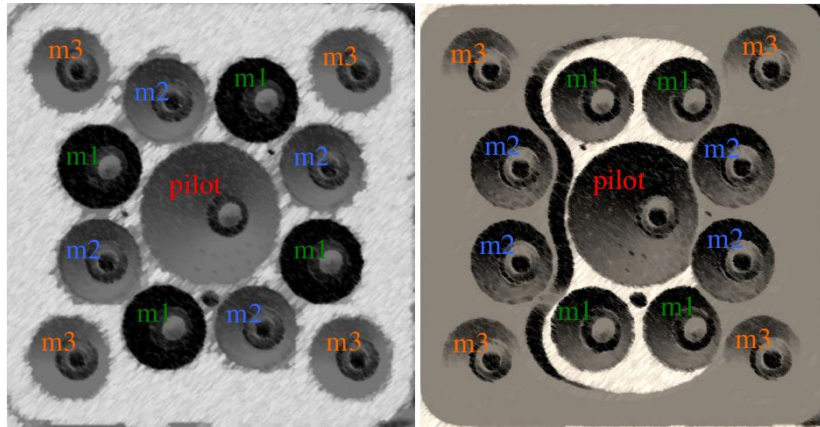

Figure 39. Flat and 5-Recess MLDI by Woodward FST [94]

Configuration	Pilot Injector	Pilot Swirler	Main 1 Injector	Main 1 Swirler	Main 2 Injector	Main 2 Swirler	Main 3 Injector	Main 3 Swirler
Flat Dome	Simplex	55°ccw	Simplex	45°cw	Airblast	IAS: 45°cw OAS: 45°cw	Airblast	IAS: 45°cw OAS: 45°cw
5-Recess	Airblast	IAS: 57°cw OAS: 57°ccw	Simplex	45°cw	Airblast	IAS: 45°cw OAS: 45°ccw	Airblast	IAS: 45°cw OAS: 45°ccw

OAS: Outer air swirler IAS: Inner air swirler CW=clockwise CCW=counter clockwise

Table 4 Second generation of NASA MLDI configurations by Woodward FST [94]

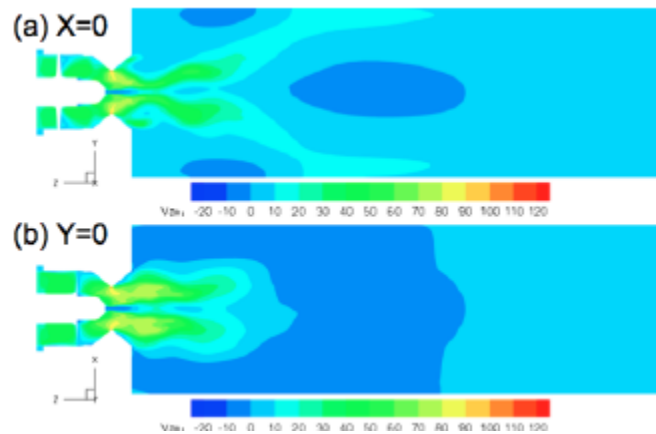

Figure 40. Non-reacting CFD computations for NASA MLDI with single component simulation showing the axial flow velocity in 2-D plane [92]

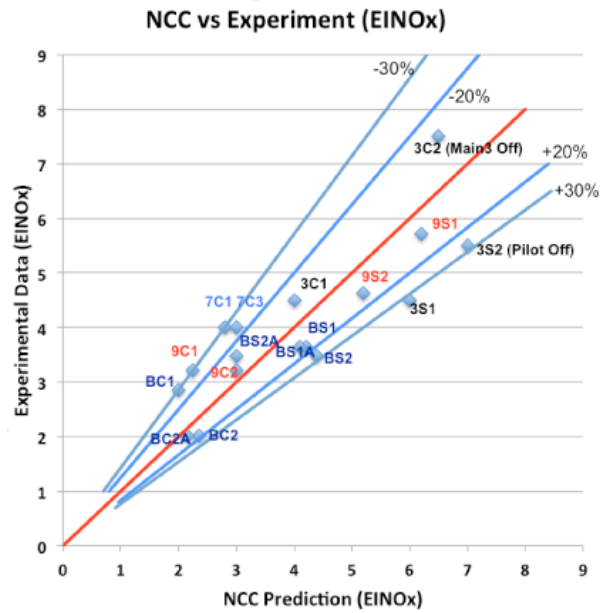

Figure 41. The NCC CFD predictions for EINO_x were within of 30% the Woodward FST experimental data for with varying pressure drops, fuel-air ratios and fuel-staging between the Pilot stage and the three Main stages [93]

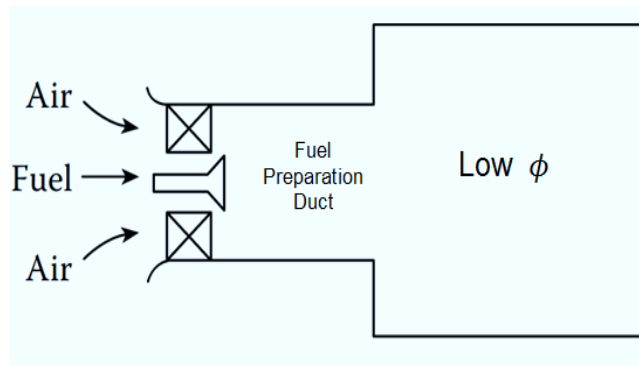

Figure 42. Schematic concept of lean premix-prevaporiser showing the fuel and air are premixed before entering into combustor zone [9]

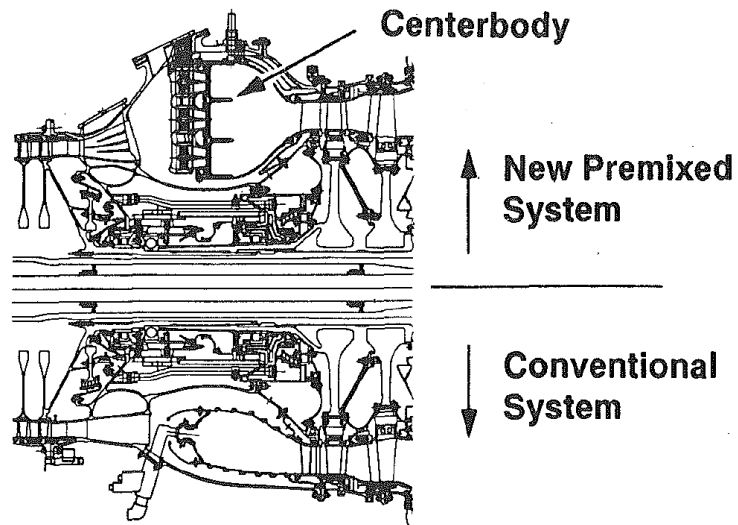

Figure 43. Comparison of LPP (top) and the conventional LM6000 (bottom) [100]

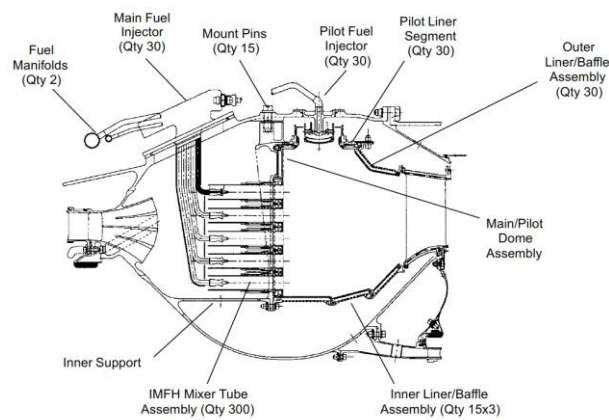

Figure 44 LPP MRA Combustor [106]

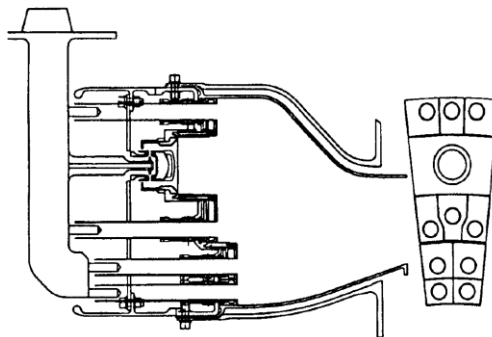

Figure 45 LPP stepped dome Concepts [106]

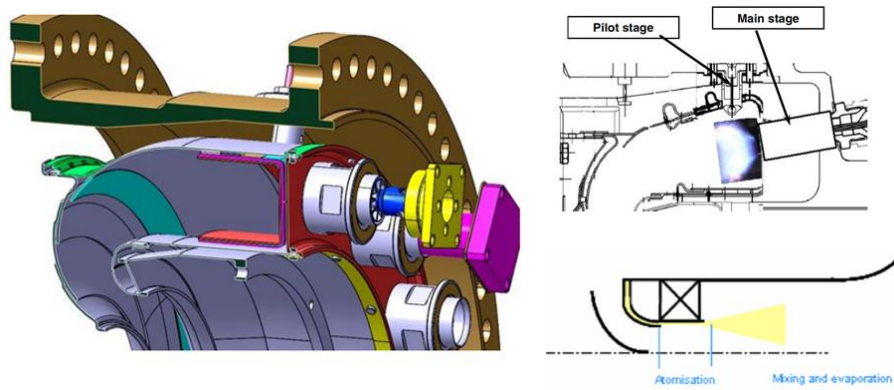

Figure 46 LPP reverse flow combustor by Turbomeca under NEWAC programme [108][109]

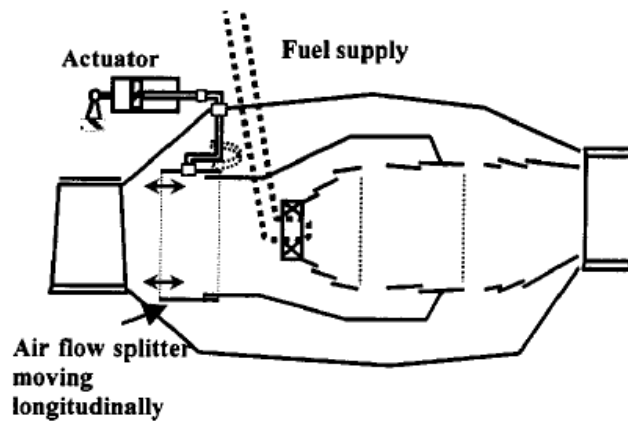

Figure 47. The variable geometry concept schematics [113]

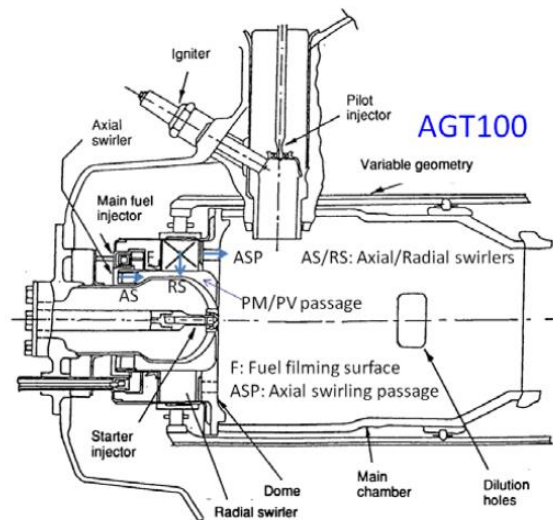

Figure 48 AGT100 LPP with variable geometry combustor [155]

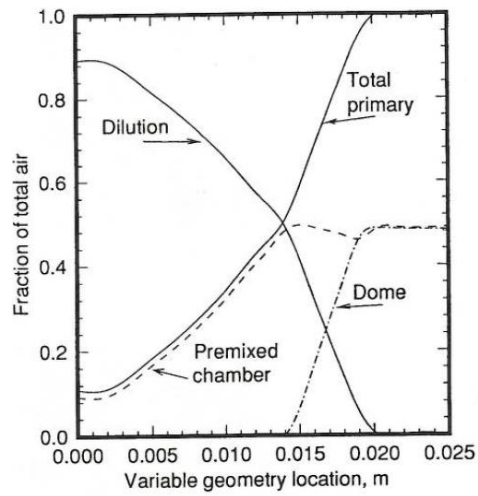

Figure 49 Air split vs sliding band location [156]

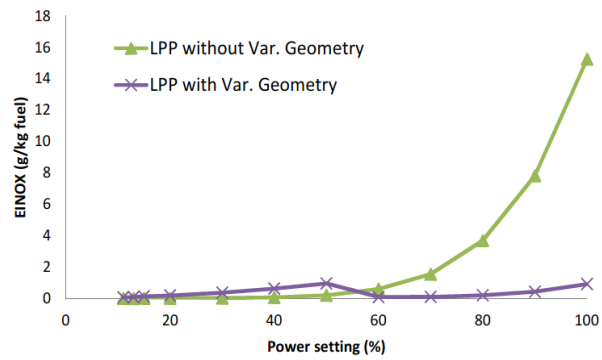

Figure 50 The predicted EI_{NO_x} vs Power setting for LPP with and without variable geometry using chemical reactor model [103]

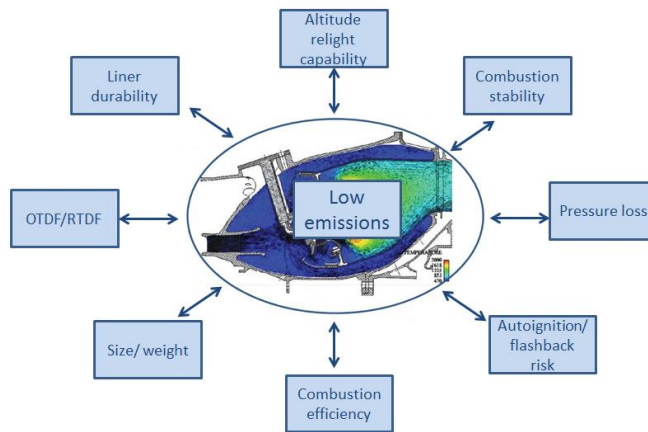

Figure 51 Interrelated combustor design considerations (combustor image adapted from [157])

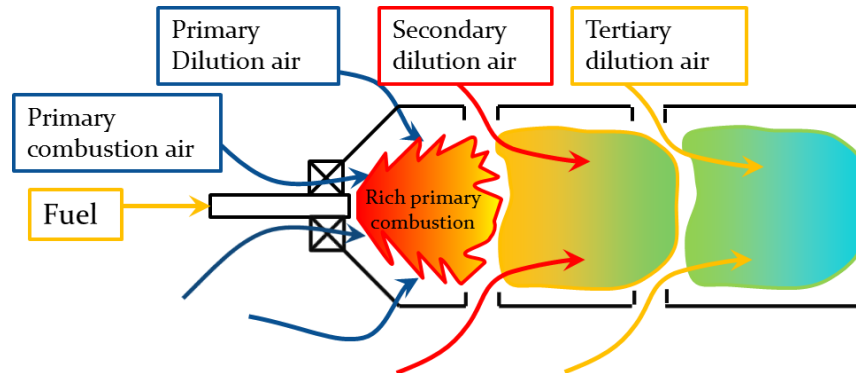

Figure 52. The schematic representation for a conventional combustor [158]

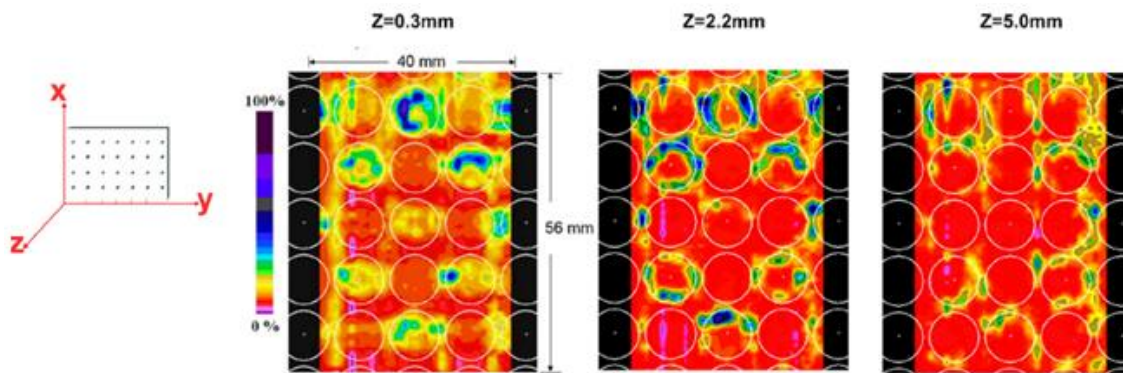

Figure 53. The end view of fuel distribution image by PLIF for the middle of array section of MLDI [150]

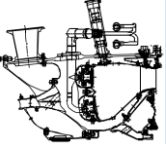

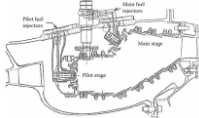
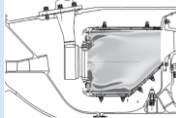

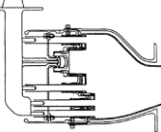
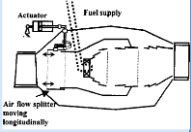
	Criterion	RQL	DAC	ASC	TAPS	LDI	MLDI	LPP	VGC
NO.	Schematics [27][10][9][136] [137][87][106][113]								
1	TRL (9)	9	9	≤5	9	≤7	≤5	≤5	< 5(for aeros)
2	Altitude relight capability	High	Moderate	Moderate	Moderate	Moderate	Low	Moderate	Higher
3	Autoignition/ flashback risk	Low	Low	Low	Moderate	Low	Low	High	Low
4	Combustion stability	High	Moderate	Moderate	Moderate	Moderate	Moderate	Low	Moderate
5	Combustion efficiency (High power)	High	High	High	High	High	High	High	High
6	Combustion efficiency (Low power)	High	High	Higher	High	High	High	High	Higher
7	Pressure loss	Moderate	Moderate	Moderate	Moderate	Moderate	High	Moderate	High
8	LTO NOx (high power)	Low	Lower	Lower	Even Lower	Even Lower	Even Lower	Lowest	Lower
9	LTO CO (low power)	Moderate	Higher	Moderate	High	High	High	High	Low
10	LTO UHC (low power)	Moderate	High	Low	Low	Low	Low	Low	Low
11	Smoke number	High	Moderate	Low	Low	Low	Low	Low	Low
12	Weight	Moderate	Heavy	Heavy	Moderate	Moderate	Moderate	Moderate	Heavy
13	Fuel coking risk	Moderate	Moderate	Higher	Moderate	High	High	Moderate	Moderate
14	Liner life	Moderate	Moderate	Moderate	Long	Long	Long	Long	Moderate
15	OTDF/RTDF quality	High	Moderate	High	Higher	Higher	Higher	Higher	Moderate

Table 5. Summary of the reviewed low emissions combustion performance based on qualitative assessment