



**QUEEN'S
UNIVERSITY
BELFAST**

Magnetic field generation from a foil-coil target using kJ-ns class lasers

Singh, S., Ahmed, H., Dudzak, R., Dostal, J., Chodukowski, T., Giuffrida, L., ... Kar, S. (2016). Magnetic field generation from a foil-coil target using kJ-ns class lasers. In 43rd European Physical Society Conference on Plasma Physics, EPS 2016: Proceedings European Physical Society (EPS).

Published in:

43rd European Physical Society Conference on Plasma Physics, EPS 2016: Proceedings

Document Version:

Publisher's PDF, also known as Version of record

Queen's University Belfast - Research Portal:

[Link to publication record in Queen's University Belfast Research Portal](#)

Publisher rights

Copyright 2016 The Authors.

This is an open access article published under a Creative Commons Attribution License (<https://creativecommons.org/licenses/by/4.0/>), which permits unrestricted use, distribution and reproduction in any medium, provided the author and source are cited.

General rights

Copyright for the publications made accessible via the Queen's University Belfast Research Portal is retained by the author(s) and / or other copyright owners and it is a condition of accessing these publications that users recognise and abide by the legal requirements associated with these rights.

Take down policy

The Research Portal is Queen's institutional repository that provides access to Queen's research output. Every effort has been made to ensure that content in the Research Portal does not infringe any person's rights, or applicable UK laws. If you discover content in the Research Portal that you believe breaches copyright or violates any law, please contact openaccess@qub.ac.uk.

Magnetic field generation from a foil-coil target using kJ-ns class lasers

S. Singh¹, H. Ahmed², R. Dudzak⁴, J. Dostal⁴, T. Chodukowski³, L. Giuffrida¹, P. Hadjisolomu², T. Hodge², J. Hrebicek⁴, L. Juha⁴, Z. Kalinowska³, E. Krousky⁴, M. Krus⁴, P. Lutoslawski¹, M. De Marco¹, M. Pfeifer⁴, J. Skala⁴, J. Ullschmeid⁴, T. Pisarczyk³, M. Borghesi², D. Kumar¹, S. Kar²

1) *ELI Beamlines, Institute of Physics, Dolni Brezany, Czech Republic*

2) *School of Mathematics and Physics, The Queen's University, Belfast, United Kingdom*

3) *Institute of Plasma Physics and Laser Microfusion, Warsaw, Poland*

4) *Prague Asterix Laser Facility, Institute of Plasma Physics, Prague, Czech Republic*

E-mail: Sushil.Singh@eli-beams.eu

Introduction:

The generation of Mega-Gauss level magnetic fields has numerous applications in laser plasma physics, especially in the fields of laboratory astrophysics, charged particle lensing and fast ignition [1]. The magnetic field for such applications can be created by the interaction of a kJ-ns class laser with a capacitor-coil target [2-6]. This paper presents the results from a recent experiment on the generation of magnetic fields inside a wire loop connected to a flat foil, by exploiting the self-capacitance of the foil target irradiated by the Iodine Laser of the Prague Asterix Laser System (PALS). The spatial distribution and temporal evolution of the magnetic field was measured by Faraday rotation at two wavelengths using an ultrashort Ti:Sa probe beam and an approximately 350 ps long probe beam at 2ω . The data from in situ measurement demonstrates the generation of strong magnetic field from foil-coil target.

Experimental Setup:

The experiment was conducted employing the Iodine Laser (energy on target ~ 600 J, pulse duration ~ 350 ps) of Prague Asterix Laser System (PALS), Prague. The focal spot diameter of the laser on the target was ~ 80 μm , providing a peak irradiance ($I\lambda^2$) of 10^{16} - 10^{17} $\text{W}/\text{cm}^2\mu\text{m}^2$. The interaction target was a Cu foil of dimensions 4 mm x 28 mm and thickness of 50 μm . A Al wire loop of 1.1 mm diameter and 100 μm thickness was attached on one end to the interaction foil and to the ground on its other end (see Fig. 1), providing a single path for the neutralizing current to flow from the interaction target to ground. This geometry allows to optimize the current in the wire loop, hence magnetic field generation at the center of the coil. Schematic of the experimental setup is shown in Fig. 1. The two probe beams of different wavelengths were made collinear using a beam splitter before probing the coil, in order to facilitate a direct comparison between the data obtained from the two different probes. A Terbium Gallium Garnet (TGG) crystal of thickness 500 μm was placed behind the coil. The

distance between the TGG and the coil was varied from shot to shot between 300 and 1300 μm . The TGG crystal rotates the polarization of the probe beams in proportion to the magnetic field generated by the coil. A broadband Wollaston prism with high extinction ratio ($\sim 10^6$) was used to split the beams into quadrature components. Downstream of the Wollaston prism, dichroic mirrors were used to split the probe beams for polarimetry imaging (using the Ti:Sa probe) and streak camera measurement (using the 2ω probe). The polarimetry imaging using the Ti:Sa beam had a magnification of 2 using a system developed by institute of plasma physics and laser micro fusion, Warsaw, Poland [7]. B-dot probes were used as a complementary diagnostic measuring the time varying magnetic field in order to reconstruct the magnetic field at the center of the loop. The B-dot probe (RS-H 50-1, dia.=10 mm) having frequency bandwidth of 30 MHz – 2 GHz was placed at distance 28 mm from the coil center [8]. Due to the absence of an absolute calibration, the B-dot probes measured the most dominant frequencies from the coil.

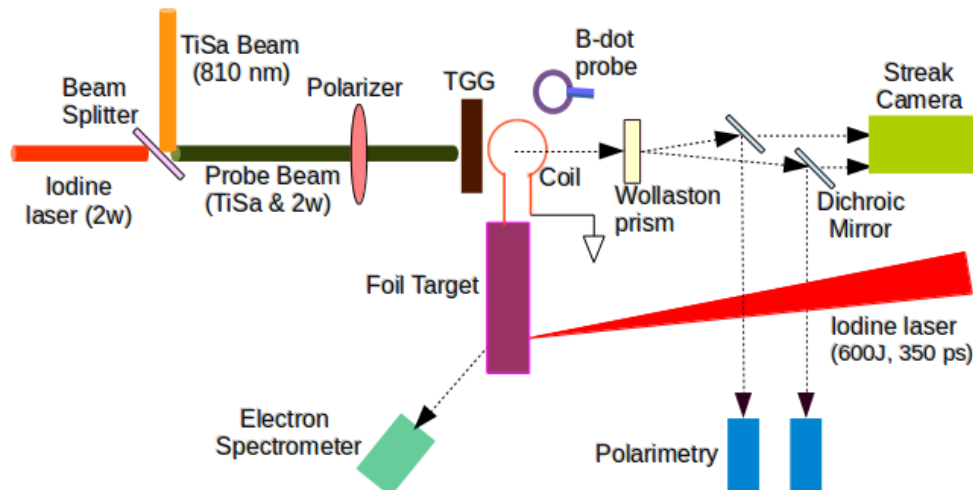

Figure 1:
The schematic of experimental set-up and diagnostics

An electron spectrometer with side a view configuration to minimize noise from incident X-ray photons [9] was specifically developed for the experiment. The electron spectrometer was installed 28 cm from the focus and had a collection opening angle of 2.46×10^{-5} sr.

Experimental Results:

In this article we present typical measurements obtained from the TiSa polarimetry imaging system and the electron spectrometer. The magnetic field at the TGG was calculated by measuring the Faraday rotation of the TiSa probe beam. The angle of Faraday rotation (θ) is linearly dependent on magnetic field (B) i.e. $\theta = V \times B \times L$, where V ($3800 \text{ degree} \cdot \text{T}^{-1} \cdot \text{m}^{-1}$) is Verdet constant of TGG medium and L (0.5 mm) is the length of optical path in the medium. Figure 2 shows a typical raw measurement of the polarization rotation angle. The boundary of

the coil and the TGG crystal are clearly visible [see Fig. 2 (a)]. The small aperture of the Wollaston prism resulted the imaging systems to have a small f-number of $\sim f/30$. Consequently the shadow of the coil caused diffraction patterns as shown in Fig 2(a). Thus, meaningful data can be obtained at the center of the coil, where the region is devoid of diffraction artifacts.

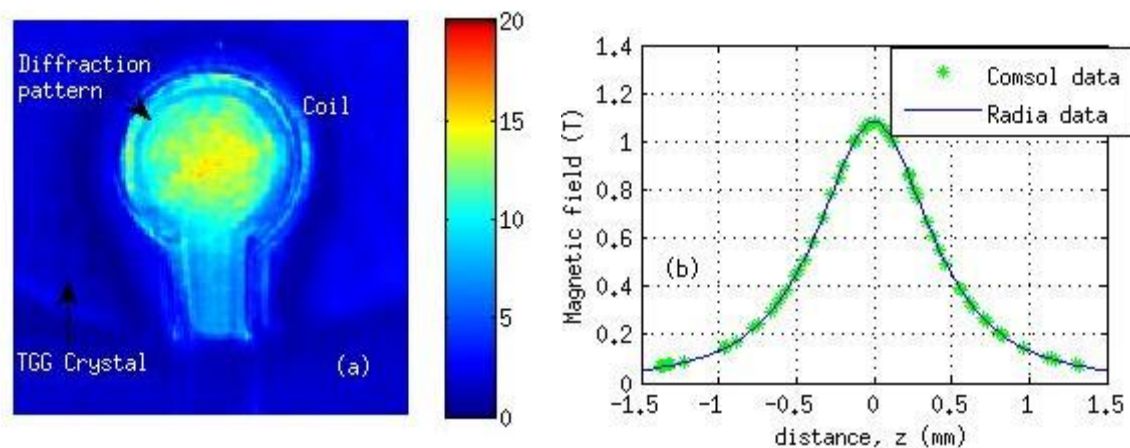

Figure 2: (a) The figure shows the experimental demonstration of Faraday rotation angle measured in degree (see color bar) using TGG crystal and TiSa beam. (b) Comparison of simulation results between radia and comsol software for magnetic field along the axis of coil ($x=y=0$) when 1kA current passing through it.

In order to scale the magnetic field measured at the location of TGG to the plane of the coil, magneto-static solvers COMSOL and RADIA [10] were used to model the field created by the coil. Figure 2b shows the spatial variation of the axial field along the center of the coil. For example, the rotation angle shown in fig 2a corresponds to a magnetic field of about 20 T at the center of the coil and a current of about 19 kA. By varying the delay of the Ti:Sa probe beam with respect to the arrival of the interaction laser on the target, we were able to measure the evolution of the current in the coil as a function of time. The data shows that the current pulse in the coil lasted for about 4 ns, thus we can estimate the total initial charge on the target to be around 80 μC .

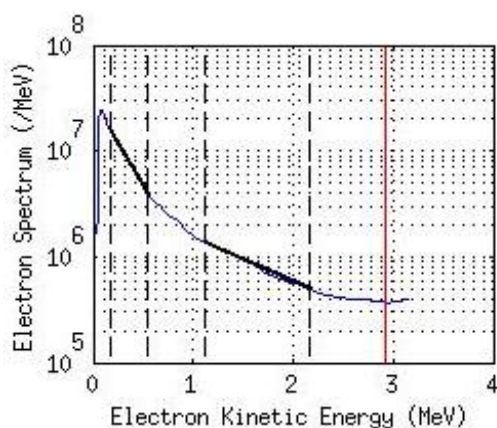

Fig. 3 shows the typical result obtained from the electron spectrometer. Since the hot electron temperature is expected to be around 100 keV [11], the spectrometer was designed to cover electron energy in the range 100 keV to 4 MeV. The typical hot electron temperature measured in our experiments was of the order of 100 keV and electron cut off energy of about 2.5-3 MeV.

Figure 3: The experimental observations of electron spectrum vs kinetic energy.

Conclusion:

In conclusion, we reported generation of strong magnetic fields (~20 T) inside a wire loop connected to a flat foil target irradiated by the Iodine Laser of the PALS. This paper presented results from polarimetry and electron spectrometer. Moreover, B-dot probe and streak camera are also used to determine the time evolution of magnetic field profile. The experimental results from other targets and diagnostics are currently under analysis and will be reported elsewhere. Such kind of laboratory generation of large magnetic fields provides an experimental test bed to explore various unresolved physics problems in basic and astrophysical plasma such as magnetic reconnection and collisionless shocks.

Acknowledgement

We gratefully acknowledge the help and support from the PALS and ELI staff members during the planning and execution of the experiment. The authors acknowledge funding from EPSRC, UK [EP/J002550/1- Career Acceleration Fellowship held by S.K., EP/L002221/1, EP/K022415/1]. This work was also supported by project ELI (Extreme Light Infrastructure) - phase 2 (Grant No. CZ.02.1.01/0.0/15_008/0000162), by the Access to the Research Infrastructure activity in the Horizon 2020 Framework Program of the EU, Grant Agreement No.: 654148 (Laser Lab Europe IV), by the Ministry of Education, Youth and Sports of the Czech Republic, project LM2015083 (PALS RI), by the Czech Science Foundation, project No.: P205/11/P712 and Ministry of Education, Youth and Sports as part of targeted support from National Programme of Sustainability II (NPU II).

References

- [1] Report on B-fields at NIF workshop held at LLNL October 12-14 (2015).
- [2] S. Fujioka et al., *Scientific Reports*, **3** (2013).
- [3] C. Courtois et al., *Journal of Applied Physics* **98.5**, 054913 (2005).
- [4] H. Daido et al., *Phys. Rev. Lett.* **56** (8 1986), pp. 846–849.
- [5] J. J. Santos et al., *New J. Phys.* **17** 083051 (2015).
- [6] X. X. Pei et al., *Phys. Plasma* **23**, 032125 (2016).
- [7] T. Pisarczyk et. al., *Phys. Plasma* **21**, 012708 (2014).
- [8] https://www.rohde-schwarz.com/cz/home_48230.html
- [9] O. V. Gotchev, P. Brijesh, P. M. Nilson et al., *Review of Scientific Instruments* **79**, 053505 (2008).
- [10] <http://www.esrf.eu/Accelerators/Groups/InsertionDevices/Software/Radia>
- [11] D. V. Giovanielli et. al. *Journal of Applied Physics* **47.7**, pp. 2907-2910 (1976).