



Suchato, Nutthawut and Kalashnikov, Alexander and Light, Roger and Sharples, Steve (2017) Experimental setup of continuous ultrasonic monitoring for corrosion assessment. In: 2017 IEEE International Ultrasonics Symposium, September 6-9, 2017, Washington D.C., USA.

Access from the University of Nottingham repository:

http://eprints.nottingham.ac.uk/45459/1/462_suchato.pdf

Copyright and reuse:

The Nottingham ePrints service makes this work by researchers of the University of Nottingham available open access under the following conditions.

This article is made available under the University of Nottingham End User licence and may be reused according to the conditions of the licence. For more details see:

http://eprints.nottingham.ac.uk/end_user_agreement.pdf

A note on versions:

The version presented here may differ from the published version or from the version of record. If you wish to cite this item you are advised to consult the publisher's version. Please see the repository url above for details on accessing the published version and note that access may require a subscription.

For more information, please contact eprints@nottingham.ac.uk

Experimental Setup of Continuous Ultrasonic Monitoring for Corrosion Assessment

Nutthawut Suchato¹, Alexander Kalashnikov², Roger Light¹, and Steve Sharples¹

¹School of Electrical and Electronic Engineering, The University of Nottingham, Nottingham, UK

²Department of Engineering and Mathematics, Sheffield Hallam University, Sheffield, UK

Email: {nutthawut.suchato, roger.light, steve.sharples }@nottingham.ac.uk¹ and A.Kalshnikov@shu.ac.uk²

Abstract—The paper is devoted to the ultrasonic monitoring of accelerated corrosion. In order to achieve non-uniform corrosion (high surface roughness), passivation was applied to the corroding surface. A dedicated electronic multiplexed four channel front end was developed in order to feed the amplified waveforms from several transducers to the recording instrument. The experiment was conducted using two 5 MHz and two 10 MHz ultrasonic transducers all operating in the pulse echo mode. The transducers were excited in turn using gated bursts, and the received echoes were multiplexed and amplified before being digitized by a high accuracy ultrasonic instrument. Application of adaptive cross correlation to the recorded data allowed continuous thickness estimation of the non-uniformly corroded surface whilst cross correlation method gave unsatisfactory results.

Keywords—non-uniform corrosion; electroplating current; accelerated corrosion; ultrasonic monitoring; ultrasonic thickness estimates

I. INTRODUCTION

In-service continuous ultrasonic thickness monitoring of ship hulls, conducted in the pulse-echo mode from inside the ships, has the potential to reduce maintenance and service costs. This technique can also help to mitigate significant inaccuracy in estimating wall thickness associated with surface corrosion while the ship is in service, provided that the cost of instrumentation and transducers is low enough for their permanent installation *in situ*, and the recorded echo waveforms can be interpreted online.

In our previous work, a test rig was developed to artificially accelerate corrosion, and to ultrasonically monitor it on steel samples [1]. Application of the constant corroding current led to artificially accelerated corrosion on the metal samples with the rate of thickness loss of hundreds of microns per hour [1]. However, the corroded samples underwent mostly uniform corrosion with low amounts of roughness whereas in many cases marine vessels undergo pitting corrosion [2].

Non-uniform corrosion with high surface roughness, complicates reliable ultrasonic thickness measurements. To monitor pitting corrosion better, the test rig had to be further developed. High surface roughness was successfully generated by applying a constant electroplating current to a sample partially covered with a protective coating, through imperfections in the latter.

Since different types of corrosion surfaces occur randomly over the corroding samples, it is possible that the use of several

channels of ultrasonic monitoring could be better to ascertain the effect of surface corrosion on ultrasonic thickness estimates. An analog front end for multiple monitoring was successfully designed to operate with a high accuracy ultrasonic instrument (HAUI) [3] for recording ultrasonic waveforms reflecting from different parts of the corroding samples.

II. DESIGN AND CONSTRUCTION OF THE EXPERIMENTAL SETUP

A. Artificially Non-Uniform Corrosion

Non-uniform corrosion is caused by the presence of abnormal either anodic or cathode sites in a normal surface of metals. This presence results in some loss of metals in the surrounded area leading to formation of cavities or holes on metal surfaces [4] [5]. Another cause of non-uniform corrosion is the presence of imperfections in a protective coating. When a passive protected layer became degraded, pits would be rapidly formed under the region of the damaged passive layer [6].

In our previous work, the electroplating current was used to force the iron ions of anode steel to dissolve in the electrolyte which caused the accelerated corrosion within short timeframes [1]. However, pitting corrosion was not observed experimentally. For the experiments reported here, the anode sample was coated with passive layers where iron ions were forced to escape through the imperfection in the passive layer. As only a small area of the passive layer had imperfections, pits or holes with high surface roughness were formed on the anode samples.

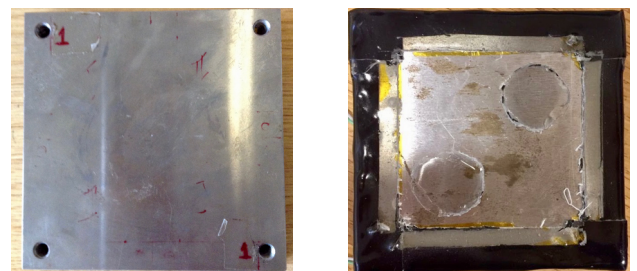

Fig. 1. Preparation of the anode samples: original mild steel plate (left), the plate tapped by waterproof glue tapes (the back region) and coated with epoxy resin with an example of two circular passive layers (right).

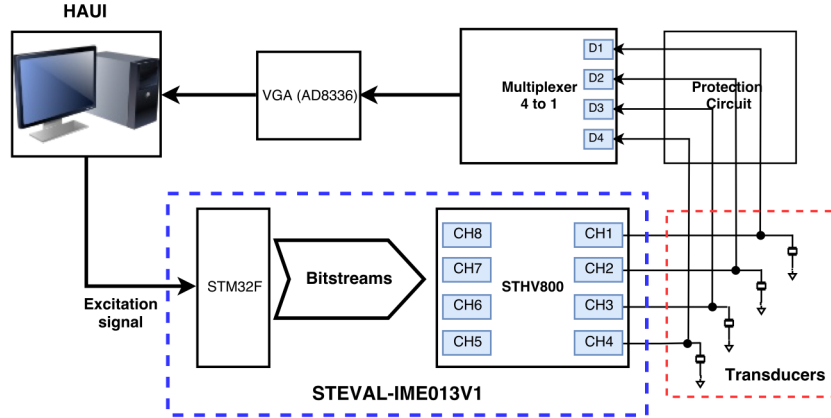

Fig. 2. Connections diagram of electronic instrumentation.

B. Preparation of the Corroding Samples

The anode metal was machined into 60 mm x 60 mm x 15 mm cubes. A working area of about 40 mm x 40 mm was left on the back wall. This working area reflected ultrasonic waves and underwent artificially accelerated corrosion. It was necessary to restrict the size of working area in order to have as high electroplating current density as possible because the high current density accelerated the dissolution of iron ions of the corroding sample in the electrolyte and influenced to degrade the passive layers [6]. Therefore, other surfaces of the anode, submerged in the electrolyte, were protected from corrosion using a waterproof glue tape and an epoxy resin. To ensure that non-uniform corrosion or pits locally occurred on the working area of anode, about 40% of the 40 mm x 40 mm exposed area, was painted with 795 clear acrylic. The anode sample prepared for the experiment is presented in Fig.1.

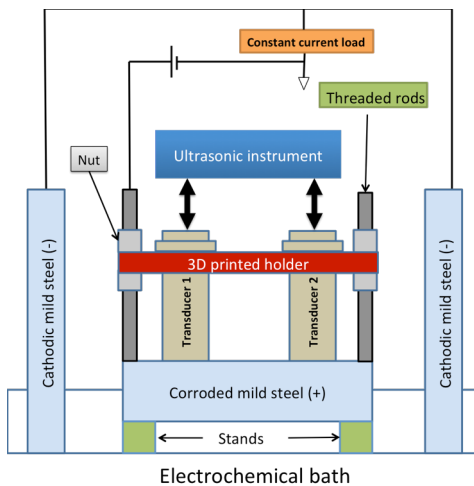

Fig. 3. Block diagram of the experimental test rig.

C. Integrating the Analog Front End for Multi Monitoring into the ADC of HAUI

Since HAUI was capable of only operating one channel, the experimental setup was limited to monitoring only one area of the corroding samples [3]. Use of only one channel does not capture all the various effect of high surface roughness. In order to record corrosion effects from different locations, an analog front end for multiple channel monitoring was designed to operate with the input of HAUI.

An evaluation board (STEVAL-IME013V1) [7], featuring a STM324 microcontroller (MCU) and a STHV800 ultrasound pulser IC, was selected to drive four transducers located on the top of corroding samples. The customized bit streams (two digit address lines) were stored in the built-in MCU Flash memory to drive four output stages of STHV800. These output stages produced unipolar output pulses with the duration equal to half the period of the center frequency of the relevant transducer.

We programmed the board to continuously drive four transducers in a sequence with the same duration of time measurement of the HAUI. A 4:1 CMOS analog multiplexer, ADG604, was used to isolate each channel. Three digit address lines from STM32F4 determined a channel selection of the ADG604 to connect to a variable gain amplifier (VGA), AD8336. The VGA amplified the ultrasonic waveforms reflected from the back wall of the corroding samples and transmitted them to the ADC port of the HAUI. In addition, transducers with high center frequencies needed high input voltages to generate high mechanical energy of ultrasound so that the ultrasound wave could propagate through the mild steel plates. Thus, the protection circuit [8] was used for the over voltage protection for the ADG604 and the VGA. The connection diagram of the completed setup is shown in Fig.2.

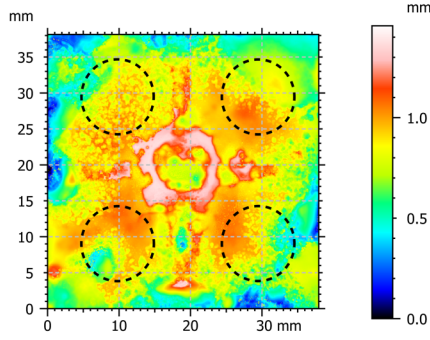

Fig. 4. Contour plot of a corroding sample with the areas monitored by the ultrasonic probes (dashed circles)

D. Construction of the Electrochemical Bath and Ultrasonic Monitoring

The typical electroplating setup was similar to our previous work [1], except for the electrolyte and the electrode metals. In this experiment, the electrochemical bath was filled with an aqueous solution of NaCl and both anode and cathode were a mild steel plate. The anode (corroding) plate allowed several transducers to be attached to it. The electroplating current value set at 1 A was sufficient for accelerated corrosion and was applied for several hours without notable dissociation of water.

The ultrasonic transducers were securely fixed to the corroding samples using 3D printed custom flange to fix their positions throughout the experiment. Two of the transducers had the center frequency of 5 MHz and two others had 10 MHz center frequencies. These center frequencies were adequate to provide superior temporal/spatial resolution. Fig.3 presents the assembled experimental setup.

Ultrasonic pulse reflections from four independent corroded spots were recorded via HAUI every one minute during the course of the experiment. We set the equivalent sampling frequency to 900 MHz and the number of averages to 512, with 3 kHz pulse repetition frequency. Under these parameters, it took 1.536 s to acquire a single echo waveform which was tolerable for corrosion monitoring. The amplitude of the excitation pulse applied to the transducer and the gain of the receiver amplifier, were set at 60 V and 25 dB, respectively.

III. EXPERIMENTAL RESULTS

A. Evaluation of the Surface Corrosion

Several anode samples were corroded using the reversed electroplating technique for varying time. At the end of each experiment, a surface of the corroded samples was scanned using InfiniteFocus measurement system manufactured by Alicona [9]. The surface images were obtained using the Mountain® surface imaging and metrology software [10].

When an electroplating current of 1 A was applied to the anode samples, the passive layers were easily pierced. The

degraded areas resulted in initiation of pits or holes despite the surrounding protection area remained intact. As a result, high surface roughness became observable on the corroding samples. The non-uniform corrosion was evident in the middle of area coated with the passive layer as shown in Fig.4.

In addition, it was found that when the protective coating was employed to some areas, the pits were formed easily contrary to the samples without the protective coating. Fig.4 presents examples of the pitting corrosion occurred under the ultrasonic transducers.

B. Analysis of Continuous Ultrasonic Monitoring for Corrosion Assessment

Fig.5 and Fig.6 present recorded waveforms reflected from different rough surfaces. When the corroding sample underwent corrosion, the 1st and 2nd echoes became poorly correlated as shown in Fig.6. Straightforward cross-correlation (XC), common time based algorithm to determine arrival times by estimating the time delay between two pulse echoes, was unable to adequately cope with these echoes. On the contrary to this, application of the adaptive cross correlation (AXC) method, determining arrival time by estimating the time delay between consecutive 1st back wall echoes [11], allowed the calculation of some reasonable thickness estimates as shown in Fig.7.

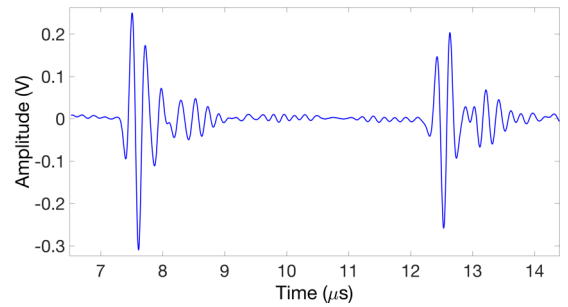

Fig. 5. The pulse echoes with 5 MHz center frequencies from reflections at the top left of back wall of a corroded sample after 301 mins of corrosion.

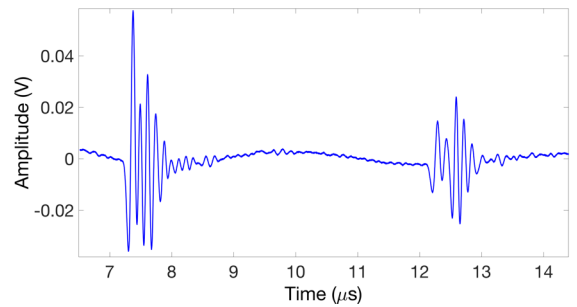

Fig. 6. The pulse echoes with 10 MHz center frequencies from reflections at the bottom left of back wall of a corroded sample after 303 mins of corrosion.

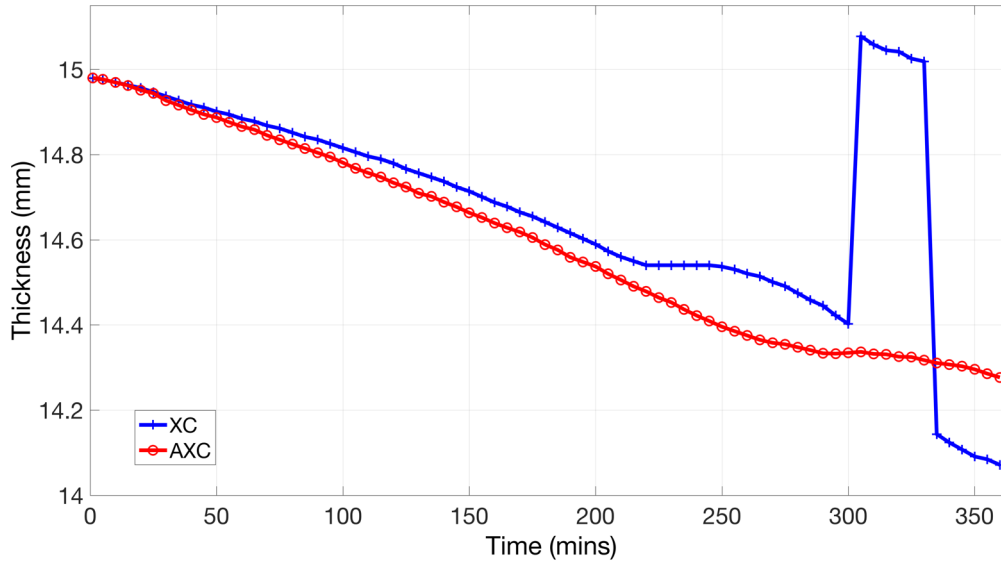

Fig. 7. The corroded plate thickness versus time evaluated using XC (blue line) and AXC (red line) respectively.

IV. CONCLUSIONS

The test rig for continuous ultrasonic monitoring of accelerated corrosion was further developed for the experimental evaluation of non-uniform corrosion. By applying a constant electroplating current to a passive layer, non-uniform with high surface roughness was successfully achieved. Ultrasonic monitoring of several channels allowed getting better characterization of corrosion and consistent thickness estimates. The AXC method was found superior to the XC method when the accelerated corrosion was of the pitting type.

ACKNOWLEDGMENT

This work was supported by Royal Thai Navy and partially supported by Optics and Photonics Research Group. The authors would like to thank M. Hirsch for his help.

REFERENCES

- [1] N. Suchato, S. Sharples, and A. Kalashnikov, "Design and experimental evaluation of a test rig for ultrasonic monitoring of accelerated corrosion," in *2016 International Conference for Students on Applied Engineering (ISCAE)*, Oct 2016, pp. 147–152.
- [2] R.E. Melchers, "The effect of corrosion on the structural reliability of steel offshore structures," *Corrosion Science*, vol. 47, pp. 2391–2410, 2005.
- [3] A. N. Kalashnikov, V. G. Ivchenko, R. E. Challis, and B. R. Hayes-Gill, "High-accuracy data acquisition architectures for ultrasonic imaging," *Ultrasonics, Ferroelectrics, and Frequency Control, IEEE Transactions on*, vol. 54, no. 8, pp. 1596–1605, 2007.
- [4] Pitting corrosion, NACE International, available online on <https://www.nace.org/Pitting-Corrosion>, accessed Jul 2016.
- [5] Non-uniform corrosion, CORROSIONPEDIA, available online on <https://www.corrosionpedia.com/definition/1674/non-uniform-corrosion>, accessed Jul 2016.
- [6] D. Kuang and Y. Cheng, "Understand the {AC} induced pitting corrosion on pipelines in both high ph and neutral ph carbonate/bicarbonate solutions," *Corrosion Science*, vol. 85, pp. 304 – 310, 2014.
- [7] STMicroelectronics, *STEVAL-IME013V1*, available online on <http://www.st.com/en/evaluation-tools/steval-ime013v1.html>, accessed Jul 2016.
- [8] W. Chen, "Low cost instrumentation for high temporal resolution ultrasonic NDE with applications to solid objects," *PhD thesis, Electrical and Electronic Engineering-University of Nottingham*, 2010.
- [9] Alicona, *Alicona infinitefocus*, available online on <http://www.alicon.com/products/infinitefocus>, accessed Jul 2016
- [10] D. Surf, *Mountains surface imaging*, available online on <http://www.digitalsurf.fr/en/mntkey.html>, accessed Jul 2016
- [11] A. Gajdacsi and F. Ceglá, "The effect of corrosion induced surface morphology changes on ultrasonically monitored corrosion rates," *Smart Materials and Structures*, vol. 25, no. 11, p. 115010, 2016.