



Durham E-Theses

Three-dimensional kinematics of the human back in the normal and pathologic spine

Hindle, Richard John

How to cite:

Hindle, Richard John (1989) *Three-dimensional kinematics of the human back in the normal and pathologic spine*, Durham theses, Durham University. Available at Durham E-Theses Online:
<http://etheses.dur.ac.uk/6513/>

Use policy

The full-text may be used and/or reproduced, and given to third parties in any format or medium, without prior permission or charge, for personal research or study, educational, or not-for-profit purposes provided that:

- a full bibliographic reference is made to the original source
- a [link](#) is made to the metadata record in Durham E-Theses
- the full-text is not changed in any way

The full-text must not be sold in any format or medium without the formal permission of the copyright holders.

Please consult the [full Durham E-Theses policy](#) for further details.

Academic Support Office, Durham University, University Office, Old Elvet, Durham DH1 3HP
e-mail: e-theses.admin@dur.ac.uk Tel: +44 0191 334 6107
<http://etheses.dur.ac.uk>

**Three-Dimensional Kinematics of the Human Back in the
Normal and Pathologic Spine**

by

Richard John Hindle

**A Thesis submitted in partial fulfillment
of the requirements for the degree of
Doctor of Philosophy**

School of Engineering and Applied Science

The University of Durham

1989

The copyright of this thesis rests with the author.
No quotation from it should be published without
his prior written consent and information derived
from it should be acknowledged.

21 DEC 1990

Abstract

Copyright © 1989 by Richard John Hindle

The copyright of this thesis rests with the author. No quotation from it should be published without Richard John Hindle's prior written consent and information derived from it should be acknowledged.

This thesis investigated the relationship between the three-dimensional kinematics of the human back and spinal pathology. This required the development of a system capable of the *in vivo* measurement of spinal movement non-invasively and in three-dimensions. The opto-electronic CODA-3 Scanner proved unsatisfactory in this respect. The electro-magnetic 3SPACE Isotrak, however, was found to be an accurate and reliable system during a study of twisting in flexed postures. Available axial rotation was significantly increased in some degree of sagittal flexion suggesting that this may be a mechanism for intervertebral disc injury. At high degrees of sagittal flexion a reduction in available axial rotation was noted. *In vitro* tests on isolated lumbar motion segments confirmed the increase in axial rotation available in flexed postures shown *in vivo*, this was presumed to be due to an opening of the lumbar zygapophysial joints. Mechanical testing of lumbar interspinous and supraspinous ligaments showed them to be active only in the extremes of sagittal flexion and hence that they could be responsible for the reduction in axial rotation seen *in vivo*. The 3SPACE Isotrak was used in a clinical study of 80 normal and 43 pathologic subjects. In the normals ranges of motion were, in general, reduced with increasing age in both males and females although a significant increase in sagittal flexion occurred with increasing age in females. Male mobility significantly exceeded female in sagittal flexion but female tended to exceed male in extension, lateral bend and axial rotation. Opposite axial rotation occurred consistently upon lateral bend and *vice versa*, flexion also occurred on lateral bend but not axial rotation. There was widespread disruption to the primary and coupled movements of the back pain patients when compared to normal movement patterns but there was no clear distinction between the kinematic movement patterns of discrete patient groups. The small numbers in these patient groups warrant a further, more detailed, clinical study.

Acknowledgements

I primarily wish to express my sincere thanks to my supervisor, Dr Mark Percy, for his ceaseless guidance, support and enthusiasum during this project.

I would also like to thank the many other people that have helped me during the course of this project. I am grateful to Professor Tony Unsworth for standing in during Dr Percy's sabattical leave and to Dr Garth Johnson and Dr Jessica Gill of Newcastle University for their invaluable help during the first months of the project. I would also like to thank the two clinicians involved later in this study; Mr Tony Cross, consultant orthopaedic surgeon at Sunderland General Hospital, and Mr David Miller, consultant orthopaedic surgeon at North Tees General Hospital, for making their patients available and for their help in collating their patients' details. Thanks are also due to the people who assisted me in the measurement of the normal subjects namely Dr Percy, Professor Unsworth and Val Rhind, who managed to find most of the female subjects for the study. Most of the male subjects in the study were volunteers from the School of Engineering and Applied Science whom I would like to thank along with all the patients and subjects who participated in the study. Much of the experimental work could not have taken place without the considerable time spent by Angela Laidler in providing specimens. I should also like to thank George Turnbull and the other technicians who assisted me in the School and to Wendy and Janet for their expert secretarial skills. Thanks are also due to Joyce Perkins for her assistance in the production of this thesis.

Finally, I would like to thank all the friends that made my time in Durham such an enjoyable one.

Contents

Abstract	I
Acknowledgements	III
1 Introduction and Literature Review	1
1.1 Introduction	1
1.2 Lumbar Spinal Movement and Pathology	1
1.3 Measurement of Lumbar Spinal Movement	5
1.4 In Vivo Measurement of Lumbar Spinal Motion	5
1.4.1 One and Two-Dimensional Measurement of Lumbar Movement	5
1.4.2 Limitations of One and Two-Dimensional Methods	10
1.5 Three-Dimensional Measurement Techniques	14
1.5.1 Limitations of Available Three-Dimensional Measurement Systems	16
1.6 In Vitro Measurement of Spinal Movement	17
1.7 Summary	17
1.8 Aims of the Thesis	18
2 Evaluation of Two New Measurement Techniques	19
2.1 Introduction	19
2.2 The Role of Torsion in the Aetiology of Spinal Injury	19
2.3 The CODA-3 Scanner	22
2.3.1 Procedure	26
2.3.2 Data Analysis	27
2.3.3 Results	27
2.4 Discussion of the CODA-3 Trial	36
2.5 The 3SPACE Isotrak	38
2.5.1 Resolution of the 3SPACE System	40
2.5.2 Accuracy of the 3SPACE System	41
2.5.3 Repeatability of Measurements	42
2.5.4 Attachment of the Source and Sensor to Subjects	42
2.5.5 Variation in Sensor Placement	46
2.5.6 Movement Repeatability	49

2.5.7	Day to Day Variation	53
2.5.8	Rotational Mobility of the Spine Measured with the 3SPACE System	59
2.5.9	Procedure	60
2.5.10	Results	60
2.6	Discussion of Twisting in Flexed Postures	61
2.7	Conclusions of the Twisting Studies	68
2.8	A Preliminary Assessment of the 3SPACE Isotrak	69
3	In Vitro Studies	70
3.1	Introduction	70
3.2	The Mechanical Function of the Posterior Ligaments	70
3.2.1	Procedure	74
3.2.2	Test Material	76
3.2.3	Results	77
3.2.4	Discussion	82
3.2.5	Conclusions	86
3.3	Motion Segment Studies	87
3.3.1	Apparatus	87
3.3.2	Procedure	90
3.3.3	Results	95
3.3.4	Discussion	108
3.4	Conclusions	109
4	Normal Movements	110
4.1	Introduction	110
4.2	Subjects	110
4.3	Procedure, Data Analysis and Statistics	112
4.4	Results	120
4.5	Ranges of Movement	120
4.5.1	Analysis of Differences in Ranges of Movement Between Sexes	121
4.5.2	Analysis of Differences in Ranges of Movement Between Ages	122
4.6	Kinematic Results	124
4.6.1	Analysis of Differences in Kinematics between the Sexes	125
4.6.2	Analysis of Differences in Kinematics between Ages	130

4.7	Coupling	132
4.8	Discussion	135
4.9	Conclusions	141
5	Clinical Study	143
5.1	Introduction	143
5.2	Procedure	143
5.3	Results	144
5.3.1	North Tees General Patient Results	144
5.3.2	Sunderland General Patient Results	155
5.4	Discussion	166
5.5	Conclusions	169
6	Concluding Remarks	171
	Bibliography	173
A	Computer Programs used for Data Analysis	188
B	Regression Plots of Age on Movement	205
C	Normal Subject Kinematic Movement Plots	218
D	Patient Clinical Assessment Forms	243
E	Patient Movement Assessment	247
F	Patient Movement Plots	253
G	Sunderland Patient Details	269
H	Prior Publications	271

LIST OF FIGURES

2.1	Rotation Available at Lumbar Zygapophysial Joints in the Normal and Flexed Spine	21
2.2	The CODA-3 Scanner	22
2.3	The CODA-3 Scanner and Associated Computer Hardware	24
2.4	The Two Marker Rigs in Place on a Subject	25
2.5	A Subject Positioned in the Standing Frame Performing Axial Rotation	28
2.6	A Subject Performing Axial Rotation in the First Seated Posture	29
2.7	A Plot of a Subject Twisting whilst Standing	32
2.8	A Plot of a Subject Twisting whilst Sitting	33
2.9	A Plot of a Subject Twisting whilst Sitting Flexed	34
2.10	Mean Axial Rotation Produced in the Three Postures Marked with their Standard Deviations	35
2.11	A Graph Showing the Relationship between Axial Rotation and Flexion	37
2.12	The 3SPACE Isotrak showing the Electronics Box, Source and Sensor	39
2.13	Regression Line for Clinometer versus 3SPACE reading	43
2.14	The Source and Sensor in Place on a Subject	47
2.15	A Subject Flexing and Extending Five Times in Succession	50
2.16	A Subject Performing Lateral Bend Five Times in Succession	51

2.17	A Subject Performing Axial Rotation Five Times in Succession	52
2.18	Mean and ± 2 Standard Deviations of a Subject Performing Flexion and Extension Five Times in Succession.	55
2.19	Mean and ± 2 Standard Deviations of a Subject Performing Lateral Bend Five Times in Succession.	56
2.20	Mean and ± 2 Standard Deviations of a Subject Performing Axial Rotation Five Times in Succession.	57
2.21	A Plot of a Subject Performing Axial Rotation Standing	62
2.22	A Plot of a Subject Performing Axial Rotation whilst Sitting	63
2.23	A Plot of a Subject Performing Axial Rotation whilst Sitting Flexed	64
2.24	Axial Rotation in the Three Postures	65
2.25	The Relationship between Flexion and Axial Rotation	66
3.1	A Ligament in Position	75
3.2	A Typical Response of an L3-4 Interspinous/Supraspinous Ligament Complex	78
3.3	Ligament Response at Different Distances from the Centre of Rotation	80
3.4	Response of a Combined Ligament Specimen and of the Interspinous Ligament Alone.	81
3.5	Response of a Specimen Tested at High and Low Strain Rates.	83
3.6	The Torsion Testing Apparatus	88
3.7	The Torque Producing Section	89
3.8	20 Nm Calibration Curve	91
3.9	Presentation of Torque Response Characteristics	92
3.10	A Motion Segment in Place for Testing	94
3.11	Characteristics of Specimen 1	98
3.12	Characteristics of Specimen 2	99

3.13	Characteristics of Specimen 3	100
3.14	Characteristics of Specimen 4	101
3.15	Characteristics of Specimen 5	102
3.16	Specimen 1	103
3.17	Specimen 2	104
3.18	Specimen 3	105
3.19	Specimen 4	106
3.20	Specimen 5	107
4.1	A Subject Performing Flexion and Extension.	113
4.2	A Normalised Plot of a Subject Performing Flexion and Ex- tension	115
4.3	Ten 20-29 Year Old Subjects Performing Flexion and Exten- sion	117
4.4	The Mean Plots of Flexion and Extension for (a) Ten 20-29 Males and (b) Ten 20-29 Females	118
4.5	The t-Statistic Showing the Differences Between Groups (a) and (b) at the 95% Level	119
4.6	A Plot of 80 Normals Performing Flexion and Extension	126
4.7	A Plot of 80 Normals Performing Lateral Bend	127
4.8	A Plot of 80 Normals Performing Axial Rotation	128
5.1	Normal and North Tees Patient Groups Performing Flexion and Extension	148
5.2	Normal and North Tees Patient Groups Performing Lateral bend	149
5.3	Normal and North Tees Patient Groups Performing Axial Ro- tation	150
5.4	Normal and Sunderland Patient Groups Performing Flexion and Extension	159
5.5	Normal and Sunderland Patient Groups Performing Lateral Bend	160
5.6	Normal and Sunderland Patient Groups Performing Axial Ro- tation	161

LIST OF TABLES

2.1 Flexion and Extension Measured by CODA-3 and by 3-D X-RAY	31
2.2 Clinometer versus 3SPACE reading	41
2.3 Repeatability Trials	42
2.4 The Effect of Varying Sensor Placement Showing the Change from the L-1 Position for each Movement	49
2.5 Standard Deviations from Five Repeated Movements in Three Subjects	54
2.6 Standard Deviations for Two Subjects' Movements on 5 days	58
2.7 Results of the Ten Day Trial	59
3.1 Details of the Specimens and Maximum Extension Moment and Force they Produced	79
3.2 Details of the Specimens tested at both High and Low Strain Rates.	82
3.3 Specimen Details	95
3.4 Characteristics of the Specimens	96
4.1 Normal Subject Age Details	111
4.2 Ranges of Maximum Voluntary Movements	121
4.3 Ranges of Movement in Males and Females	121
4.4 ANOVA Summary Table for Sex Differences	122
4.5 ANOVA Summary Table for Differences Between Ages	123
4.6 Correlation Coefficients for Age on Movement	124
4.7 Significant Differences from t-tests between Sexes	129

4.8	Significant Differences from t-tests between Ages in Males	130
4.9	Significant Differences from t-tests between Ages in Females	131
4.10	Results of the Chi-Squared Analysis of Coupled Movements	133
4.11	Correlation Coefficients (r_{xy}) Showing the Strength of Cou- pled Lateral Bend on Axial Rotation	133
4.12	Correlation Coefficients (r_{xy}) showing the strength of Cou- pled Axial Rotation on Lateral Bend	134
4.13	Correlation Coefficients (r_{xy}) showing the Strength of Cou- pling between Lateral Bend and Flexion	135
4.14	Ranges of Normal Lumbar Motion as Measured by 3SPACE Isotrak and 3-D X-RAY	137
5.1	North Tees Patient Details	145
5.2	North Tees Patient Diagnoses	146
5.3	Side of Pain and Abnormality of Movement in North Tees Patients	152
5.4	North Tees Patient Clinical Movement Assessment	154
5.5	Sunderland Patient Details	156
5.6	Sunderland Patient Diagnoses	158
5.7	Side of Pain, Pathology and Restriction in Movement in Sun- derland Patients	163
5.8	Sunderland Patient Clinical Movement Assessment	165

Chapter I

Introduction and Literature Review

1.1 Introduction

Most people will suffer from some back pain during their lifetimes. Auchincloss (1983) has estimated that 80% of the population will experience it at some stage of their lives and Roland (1983) puts the figure closer to 100%. Most instances of back pain are short lived and the cases that result in medical consultation have been estimated to be between 3 and 10%. Nevertheless, the numbers involved are still considerable. Wells (1985) estimated that in 1983 2.2 million people consulted their General Practitioner complaining of back pain. The total cost to the National Health Service (N.H.S.) was estimated to be 156 million pounds, or 1.15% of the total N.H.S. budget, in 1982.

Back pain, clearly then, presents a considerable challenge to both the medical professionals who must confront it directly in the patient and to those scientists upon whom the responsibility for improved diagnosis and treatment rests.

The measurement of spinal motion is one of the routine clinical methods employed in the diagnosis and assessment of low back pain patients and yet this area has received relatively little consideration in comparison to other spheres of back pain management.

1.2 Lumbar Spinal Movement and Pathology

Movements of the lumbar spine have become of interest to bioengineers and

clinicians for two main reasons. Firstly, movements have been implicated in the aetiology of various spinal disorders and secondly, alterations to normal movements have been linked to pathological conditions of the lumbar spine. The involvement of movements in the aetiology of various spinal pathologies is considered in some detail in Chapter 2.

Clinicians will generally perform some sort of assessment of movement when presented with a patient complaining of low back pain. Despite this there has been little research conducted to investigate the exact relationship between movement and pathology.

One condition in which the measurement of movement is well documented is Ankylosing Spondylitis. This inflammatory condition results in the calcification of the spinal ligaments and intervertebral discs as part of the response to the inflammation. Limitation of lumbar spinal movement is recognised as one of the most important diagnostic criteria in the evaluation of the disease (Bennett and Birch 1968, Macrae and Wright 1969).

A number of researchers have also described altered flexion-extension mobility in the diagnosis of degenerative disc disease.

Various workers have used information from lateral plane radiographs of patients in flexion and extension to make comparisons to normals. Gianturco (1944) noted several types of deviation from the normal pattern of motion in a high percentage of his patient group although he does not relate this abnormal movement to their respective pathologies. Tanz (1953), Aho *et al* (1955) and Jirout (1957) all noted a decrease in segmental flexion-extension in low back pain patients. Mensor and Duvall (1959) measured flexion-extension of lumbar intervertebral

joints in a study of 94 normal and 527 symptomatic subjects. No statistical analysis was performed but they do report that 15% of the asymptomatic subjects showed absence of motion at one or both of the two lower lumbar intervertebral levels as opposed to 43% of the patients with low back pain. More recently Pennal *et al* (1972) using their "point of motion system" reported a difference in lumbar motion between pathologic and normal subjects in 65% of intervertebral joints studied. These radiographic studies have concerned themselves with segmental mobility but Mayer *et al* (1984), using an inclinometer, have recently reported a reduction of lumbar flexion in patients suffering from chronic low back trouble. Burton (1987), using his flexicurve technique, also found sagittal mobility to be reduced, relative to normal, in subjects currently experiencing low back pain, although he does report that relative hyper-mobility was not unusual.

The recording of lumbar mobility has also been suggested as having predictive value. Wickstrom *et al* (1978) did find a positive relationship between limited lumbar flexion and past sciatic history in two groups of male workers. Troup *et al* (1981) also noted a similar relationship in a study of 802 workers. Anderson and Sweetman (1975), however, could not relate lumbar sagittal mobility to past history of back trouble in a study of 432 male subjects. Burton (1987) concludes his study by saying that the measurement of regional sagittal mobility of the lumbar spine can not alone predict the natural history of back and sciatic pain, rather that it is one of a large number of contributing variables.

The study of mobility in pathological conditions has largely been confined to sagittal plane movements. Mellin (1989), however has recently suggested that the measurement of lateral flexion (lateral bend) correlates better with the degree of back pain related disability than does forward flexion and argues that this would

be a more useful clinical measure.

The only studies to have looked at movement in three-dimensions have done so with a technique known as biplanar radiography, discussed in more detail later. Stokes *et al* (1981) assessed the spinal movements of low back pain patients using this technique. They reported abnormality of movement related to narrowed disc space and proximity to previous fusions. They also noted an asymmetry of motion specific to joints with a herniated nucleus pulposus. Panjabi *et al* (1984) have also observed this asymmetry in *in vitro* studies of lumbar spinal motion segments. Pearcy *et al* (1985) have also used biplanar radiography to investigate the effect of low-back pain on lumbar spinal movements. They assessed the movements of patients with back pain alone and with back pain plus nerve tension signs. Biplanar radiography was found to be able to differentiate between groups but could not provide clinically useful information concerning individual patients with this type of back pain.

The axis of rotation of a motion segment varies instantaneously as the joint flexes or extends. This is known as the instantaneous axis of rotation or IAR for short. Throughout any movement an intervertebral joint will move about a series of IARs forming a centrode of motion (Gertzbein *et al* 1985, Gertzbein *et al* 1986, Ogston *et al* 1986 and Seligman *et al* 1984). These can be determined by measuring radiographs of the joint as it passes from extension to flexion. Alterations to centrode patterns have been reported in cases of mechanical derangement or instability of the lumbar spine (Gertzbein *et al* 1985, Gertzbein *et al* 1986, Ogston *et al* 1986 and Seligman *et al* 1984). It has, therefore, been suggested that the determination of centrode patterns in low back pain patients may have diagnostic potential. However, Pearcy and Bogduk (1988) have recently demonstrated

that unacceptably large errors occur when the movement of the joint is less than 5° , invalidating any diagnostic potential of the clinical investigation of centrododes. However, alterations to the single extension to flexion IAR may prove to have diagnostic value. IARs are discussed further in Chapter 3.

1.3 Measurement of Lumbar Spinal Movement

Despite the scant evidence relating movement to pathology a review of the literature reveals a wealth of methods that have all been designed to measure lumbar spinal motion clinically.

1.4 In Vivo Measurement of Lumbar Spinal Motion

Over the years a large number of different approaches have been adopted in attempts to find a clinically effective method for the determination of lumbar motion.

These have been divided here, for convenience, into one, two and three-dimensional techniques (Pearcy 1986). The one-dimensional methods generally give a simple linear index of movement whereas the two-dimensional methods will also provide rotation within a plane.

1.4.1 One and Two-Dimensional Measurement of Lumbar Movement

Conventional one-dimensional techniques employed for measuring lumbar spinal motion include the skin distraction and finger to floor distance methods for the measurement of anterior flexion and the plumbline technique for measuring sagittal extension.

The skin distraction method for measuring spinal anterior flexion is probably

the most common technique in use as it is simple to perform requiring only a tape measure and a marker pen. It was originally developed by Schober (1937) and its current form was arrived at by Macrae and Wright (1969).

Three marks are inked on the skin overlying the lumbo-sacral spine with the subject standing erect. The first mark is placed at the lumbo-sacral junction as represented by the mid-point of a line joining the dimples of Venus. Further marks are placed 50 mm below and 100 mm above this. The subject then bends forward as far as possible attempting to touch the floor. The new distance between the top and bottom marks is measured and the distraction between the two lengths gives a measure of mobility.

The finger to floor distance method gives a measure of mobility by measuring the distance between a patient's outstretched finger tips and the floor while attempting to touch his or her toes. Simple commercially available devices can be used to perform this test.

Moll and Wright (1972) developed the plumb-line technique for measuring extension in which two marks are inked on the skin of the lateral trunk. The upper mark is placed at the intersection of a horizontal line through the xiphisternum with the coronal line. The bottom mark represents the the intersection of a horizontal line through the highest point on the iliac crest with the coronal line. A simple plumbline is suspended by a thread from the upper mark so that it coincides with the lower mark. As the subject extends maximally the distance traversed by the plumbline pointer is measured, giving an index of movement. The same two skin marks could be used for the measurement of lateral flexion, or bending. The distance between the two marks is measured in the upright position

and again with the subject maintaining maximal lateral flexion, the difference between the two readings giving an index of movement.

A number of techniques provide two-dimensional measures of spinal mobility including the use of instruments such as inclinometers and spondylometers and the use of single plane radiography.

The inclinometer, or goniometer, was developed by Loebel (1967) following the work of Asmussen and Heeboll-Neilson (1959) and operates on a simple pendulum principle. The inclinometer is placed over the spinous processes of L1 and S1, previously identified by palpation and marked, with the subject standing erect. Readings are taken in the erect posture and with the subject flexing maximally whilst sitting on a chair. The subject then lies prone on a couch and extends maximally, readings are again taken over the two marks. The differences between the three sets of readings give angles of flexion and extension. This technique can also be employed for the measurement of lateral bending and axial rotation. Various clinical models are available although Pearcy (1986) suggests that the much cheaper builder's inclinometer is equally as good (see also Mellin 1986).

Dunham's spondylometer (1949) has been used to assess flexion and extension of the thoraco-lumbar spine in patients suffering from Ankylosing Spondylitis. The device consists of two brass rods, hinged in the middle, the end of one being connected to a protractor. The protractor is placed over the sacrum and the free end of the other rod over the vertebra prominens, readings taken in the standing, flexed and extended postures give angles of flexion and extension.

Various workers, using a variety of methodologies, have attempted to assess spinal movements by the analysis of the spinal curvature in different postures.

Israel (1959) used a flexicurve to establish the shape of the spine. He then measured the angles of intersection of two tangents to this curve, now drawn out on a piece of paper, in two postures to estimate the movement between them. His sample group consisted of young, female, ballet dancers which cannot be considered to be representative of the population as a whole.

Troup *et al* (1968), using a modification of the technique of Ahlback and Lindahl (1964), calculated lumbar movement from the difference between the ranges of flexion/extension at the hip joints and of the hips and lumbar spine combined. This method, however, was considered to be too complicated and time consuming for routine clinical usage as well as involving considerable discomfort for the patient.

Anderson and Sweetman (1975) describe the flexirule/hydrogoniometer for the measurement of sagittal lumbar mobility. The device consisted of two hydrogoniometers attached directly to a flexirule. Readings of spinal curvature could then be taken directly from the subjects back without the need for tracing the shape of the flexirule.

More recently Burton (1986) has developed the flexicurve technique for the measurement of sagittal mobility to allow identification of regional mobility within the lumbar spine. The technique involves the identification of three anatomical landmarks; the spinous processes of S2, L4 and T12. The flexicurve is moulded to the subject in maximum flexion and extension and the contours subsequently recorded. Tangents are then drawn to both flexion and extension curves at the S2, L4 and T12 points. The angles formed by the intersection of these tangents are measured by a protractor and are used to produce measures

of the sagittal mobility occurring in the upper and lower lumbar spine.

Adams (1986) describes an electronic goniometer for the measurement of lumbar curvature from which he was able to measure sagittal flexion which correlated well with radiographic measures of flexion.

Marras and Wongsam (1986) describe the use of a "lumbar monitor" in a study of sagittal plane flexibility and velocity of the lumbar spine. The device, which is commercially available, consists of a series of stiff wires placed against the lumbar spine, angular position was measured with a precision potentiometer attached to one of the wires. An indication was not given as to the accuracy or repeatability of the device.

The literature contains many reports of single plane radiography being used to give angles of flexion-extension (Gianturco 1944, Begg and Falconer 1949, Tanz 1953, Aho *et al* 1955, Allbrook 1957, Jirout 1957, Pennal *et al* 1972, Hanley 1976 and Hayes *et al* 1989) and lateral bend (Miles and Sullivan 1961, Dimnet *et al* 1978 and Weitz 1981).

The method involves superimposing radiographs of vertebrae, taken at extremes of motion, and calculating, by a variety of methods, the movement that has occurred. For example when measuring forward flexion lateral radiographs are taken with the subject first standing fully upright and then fully flexed. The upright radiograph is attached to a viewing box, the flexion radiograph is then placed over it such that the two images of the sacrum are superimposed. A line is then drawn along the edge of the flexion radiograph on a piece of paper taped to the viewing box. Lines are similarly drawn as each lumbar vertebra is in turn superimposed, the angles between the lines being the angle of flexion for each

intervertebral joint (Begg and Falconer 1949). A similar technique is employed using anterior-posterior (A-P) radiographs to determine angles of lateral bend for intervertebral joints.

The determination of axial rotation from A-P radiographs has also been reported. Nash and Moe (1969) describe the "pedicle shadow offset" technique in which rotation is classified according to how far the shadow of the pedicle moves across the face of the vertebrae during maximal axial rotation recorded on an A-P radiograph. Benson *et al* (1976) judged the technique to be poor but more recently Drerup (1985) made some modifications to the technique and reported accurate results.

The techniques reviewed so far have all recorded some objective value of lumbar movement, be it the actual angular values, an index of movement or the shape of the lumbar spine. The classification of lumbar intervertebral movements by identifying the vertebrae at the extremes of motion by palpation is common amongst physical therapists and osteopaths. Kaltenborn and Lindahl (1984) studied the reproducibility of such tests and reported good results, when the movements were classified as normal, restricted or hyper-mobile. McConnel *et al* (1986) and Gonnella *et al* (1982), however, report poor inter-observer agreement and the technique should be considered of little use.

1.4.2 Limitations of One and Two-Dimensional Methods

Despite claims of high reproducibility and accuracy most of these one and two-dimensional methods have been shown to be severely limited in their ability to reflect true lumbar spinal motion.

In an assessment of the relative merits of the spondylometer, inclinometer and skin distraction techniques Reynolds (1975) showed the inclinometer to be the only method with acceptable accuracy and reproducibility. He concluded that the skin distraction method was inaccurate and complicated.

Portek *et al* (1983) correlated a number of these methods with true lumbar spinal motion as measured by three-dimensional radiography. They concluded that the techniques requiring manual measurements are liable to large errors, the inclinometer being the only one able to provide reproducible measurement, with careful monitoring. They added that, further to this, the methods did not reflect true intervertebral motion. Single plane radiography, for flexion and extension, was the only method to correlate at all closely with true indices of movement.

Salisbury and Porter (1987) assessed the ability of kyphometer, goniometer, flexicurve, tape measure (skin distraction technique) and an ultrasound technique to measure lumbar sagittal mobility reproducibly. The three methods that measured angular movement, the goniometer, kyphometer and flexicurve, correlated well with each other and had similar degrees of repeatability. The flexicurve technique was found to be slightly less reproducible due to the error introduced in drawing tangents. The ultrasound technique they described had poor reproducibility due to the necessity of subjects having to maintain postures for upto 5 minutes at a time. The skin distraction technique did not correlate well with the other techniques. Of the techniques they assessed they recommend the goniometer as the best instrument to measure lumbar sagittal mobility.

Griffin *et al* (1984) assessed the reproducibility of a modified hydrogoniometer in a study of 350 individuals. Reproducibility for flexion (0.91) was better than

that for extension (0.75) with errors of 3° and 7° respectively.

Stokes *et al* (1987) reported on the accuracy of the measurement of lumbar sagittal mobility measured by the flexicurve technique by comparing it to radiographic measurement of the same individuals. The flexicurve technique was shown to correlate "reasonably" well with plane radiography ($r=0.58$) for total lumbar motion but poorly for intersegmental motion.

Flexion and extension are known to occur without significant lateral bend or axial rotation and this is why single plane radiography is able to provide accurate measures of them. However, it is now known that lateral bend and axial rotation do not occur individually but are accompanied by secondary, or coupled, movements in planes other than that of the primary movement.

Arkin (1950) describes the occurrence of convex-side rotation in the laterally deviated spine. In other words an accompanying opposite axial rotation occurring with lateral bend. He suggested that this phenomenon depended on soft-tissue tensions rather than the arrangement of bony elements.

Miles and Sullivan (1961) confirmed the findings of Arkin, stating that "...lateral bending was usually a combination of lateral flexion and torsion. Torsion, in most subjects, was to the side opposite that of the lateral flexion". Gregerson and Lucas (1967) also noted, in their *in vivo* studies of axial rotation, that axial rotation seemed to be integral to lateral bending.

Both Frymoyer *et al* (1979) and Pearcy (1985) have reported consistent coupling of movements in the lumbar spine *in vivo* using three-dimensional radiography. Pearcy (1985) provides the most detailed and accurate description of coupling of lumbar spine movements using the technique of stereo-radiography.

He found very little accompanying axial rotation or lateral bend with flexion or extension but reports that during both axial rotation and lateral bend there were large accompanying rotations in other planes. In axial rotation there was a consistent pattern of accompanying opposite lateral bend at the upper three lumbar levels. At L4-5 some individuals were found to have exhibited lateral bending in the same direction as the axial rotation and if lateral bending occurred at L5-S1 this was always the case. No consistent pattern of flexion or extension was found with axial rotation. In lateral bending opposite axial rotation was seen to occur consistently. During lateral bending, to both sides, the upper lumbar levels consistently displayed extension with L4-5 occasionally flexing and L5-S1 generally doing so. Like Arkin earlier, Pearcy concludes that although some degree of mechanical coupling may occur, it is more likely that the lordotic shape of the lumbar spine and muscular control are the main factors controlling accompanying rotations. Scholten and Velduizen (1985), in a modelling study, implicate the lumbar curvature in coupling but also attribute a significant role to the geometry of the zygapophysial joints. The importance of the lumbar musculature and lumbar lordosis are reflected in the inconsistency of findings of researchers reporting coupling *in vitro* (Panjabi *et al* 1977, Schultz *et al* 1979), where these factors are obviously disrupted.

To summarise, a number of one and two-dimensional techniques for the measurement of lumbar spinal motion have been considered. Of those providing measures of sagittal mobility a number can provide reasonably accurate results, most notably single plane radiography. However pathological conditions may introduce out of plane movement and so may bring even these techniques into doubt. The one and two-dimensional methods that claim to measure lateral bend

and axial rotation are again unable to take account of out of plane movements. It would appear then that only a three-dimensional measurement system can give a representative and true picture of lumbar spinal motion.

1.5 Three-Dimensional Measurement Techniques

In attempts to determine three-dimensional intervertebral motion characteristics, invasive techniques have been employed.

Gregerson and Lucas (1967) and Lumsden and Morris (1968) inserted Steinman pins into various thoracolumbar spinous processes. Direct measurements were made of the angular displacement of the pins, the technique being used primarily to assess axial rotation.

A number of workers have reported the use of three-dimensional radiographic techniques for the accurate determination of lumbar spinal movements.

Olsson *et al* (1977) describe the application of a roentgen stereophotogrammetric technique for the assessment of lumbosacral mobility after fusion. Their technique, however, required the insertion of three or more markers into each lumbar vertebra studied, these taking the form of small metal pellets inserted into needle holes made in lumbar spinous processes.

Frymoyer *et al* (1979) describe an apparatus which incorporates orthogonal radiography with a method of placing and holding subjects and moving them through indexed ranges of motion. However, securing their subjects as they did and then imposing fixed movements may have resulted in abnormal movements of the lumbar spine.

Biplanar, or stereo, radiography has been described by Stokes *et al* (1981)

and by Pearcy (1985). This technique has been used by Pearcy (1985) to provide what is to date the most complete description of the motion characteristics of the lumbar spine. Two X-ray source positions were used in conjunction with two film plates, sited orthogonally. Once stereo radiographs were obtained at the start and end points of motion the two-dimensional positions of a series of nine anatomical landmarks were digitised. The data was then processed to give angles of intervertebral movement.

More recently Plamondon *et al* (1988) describe a technique in which the subject was radiographed in both the A-P and lateral view in the upright position and then in either flexion, extension or lateral bend, the subject having to maintain a fixed posture while being rotated on a turntable between exposures. This would make the technique unsuitable for many low back pain patients for whom maintaining such postures is very painful.

Non-invasive methods have also been used to investigate back movements in three-dimensions. The vector stereograph (Thurston and Harris, 1983) is an electro-mechanical device which employs three potentiometers connected by means of return springs and capstans to three lengths of string. The free ends of the strings are attached to a belt strapped around the subject at the level of L-1. The subject's pelvis is secured in a standing frame. As the subject moves the locus of the point of attachment is recorded providing three-dimensional information about the movement of L-1 relative to the sacrum.

Whittle (1982) describes a three-dimensional television system for kinematic analysis. Television cameras are connected to a digital computer and are used to record the position of reflective markers, illuminated by stroboscopes, attached

to the subject. A television/computer interface generates the two-dimensional coordinates of these markers, a three-dimensional calibration procedure is then initiated to give angles of movement in three-dimensions. The system is commercially available as the VICON system. Pearcy *et al* (1987b) have applied this system to the measurement of back movement, recording the patterns of movement of 6 normal individuals.

1.5.1 Limitations of Available Three-Dimensional Measurement Systems

Of the available three-dimensional measurement systems stereo radiography, as described by Pearcy (1985), has provided the most accurate representation of true lumbar intervertebral motion to date. However, it has limited clinical application for a number of reasons. The inherent problem of X-ray exposure precludes its repeated use on the same subject, it is also a laborious process that requires a skilled operator and involves considerable time between initial exposure and the production of data. The equipment is expensive and, obviously, not suitable for use in the normal clinic. The insertion of Stein man pins into lumbar spinous processes is obviously a technique with no place in the clinic due to its somewhat drastic invasiveness. The non-invasive vector stereograph does provide dynamic motion patterns but it too is limited in its application due to the necessary tethering of the subjects, the equipment is somewhat cumbersome and not easily portable and the technique fails to produce results in terms of angular movement. The VICON system, although non-invasive, requires an initial calibration procedure and interactive data analysis and as a result is a complex and time consuming method.

1.6 In Vitro Measurement of Spinal Movement

As well as examining lumbar movements *in vivo* various researchers have studied the movements and mechanics of isolated spinal joints and tissues *in vitro*, some of which have already been mentioned. Further reference to *in vitro* studies are made throughout the thesis where they are considered to contribute to the understanding of the *in vivo* situation. Since this thesis is concerned with movements in the living spine a specific review of these tests has been omitted.

1.7 Summary

Evidence has been offered that suggests lumbar spinal movements may be related to pathology. However, most clinicians will only perform a subjective assessment of a patient's movements by eye. The number of clinicians realising the importance of quantifying the assessment of spinal movement is increasing, with the inclinometer and skin-distraction techniques probably being the techniques in most common usage. However, these simple techniques have been shown to have a variety of shortcomings, not least their inability to reflect the true three-dimensional nature of the movements of the lumbar spine. It would seem, therefore, that efforts should be focused on the development of alternative methods for the non-invasive, three-dimensional measurement of kinematic patterns of lumbar spinal motion. If spinal pathologies are related to specific motion patterns then it would seem that a dynamic three-dimensional picture of movement would be more likely to be of use than knowledge of the position of vertebrae at the extremes of motion. However, as Moll and Wright (1987) point out any clinical techniques should pay consideration to ease and speed of use, economy and, not least, potential harmful effects to the patient.

1.8 Aims of the Thesis

The aims of this thesis are thus:

1. To develop a three-dimensional, non-invasive, system for the kinematic analysis of lumbar spinal motion suitable for clinical usage.
2. To use this device to assess if a relationship does exist between movement and pathology.
3. To comment on the clinical relevance of the measurement of spinal movement.

Chapter II

Evaluation of Two New Measurement Techniques

2.1 Introduction

This chapter will present two new methods for the non-invasive three dimensional measurement of spinal motion; the CODA-3 scanner and the 3SPACE Isotrak. The CODA-3 scanner was assessed by looking at the possible role of torsion in the production of mechanical injury to the intervertebral disc. When the 3SPACE Isotrak became available this study was repeated to both validate the results of the CODA-3 trial and to assess the 3SPACE Isotrak in its own right.

2.2 The Role of Torsion in the Aetiology of Spinal Injury

There is considerable controversy in the literature over the role of torsion in the production of intervertebral disc degeneration and prolapse.

On one side Farfan and colleagues (1973) have maintained that torsion is the most important factor in the initiation of annular damage. They produced annular ruptures similar to those that occur *in vivo* by subjecting intervertebral joints to forced rotations finding that an average rotation of some 22.6° was required to produce failure in whole joints with normal discs. They stated that the neural arches and facet processes became distorted to permit this rotation maintaining that the normal whole joint failed without gross injury to the bone of either the vertebral body or facet joint.

The normal physiological ranges of axial rotation for the lumbar spine have been determined by Gregerson and Lucas (1967) using the measurement of Steinman pins inserted into lumbar spinous processes, as mentioned previously, and more recently by Pearcy (1985) using biplanar radiography. Both methods gave a figure of 8-10° of axial rotation for the whole lumbar spine or approximately 2° per joint. It would seem, therefore, that under ordinary circumstances it is impossible for an intervertebral joint to fail as a result of rotation. However, Farfan maintained that any joint rotated to more than 3.5° must receive injury to the disc.

More recently several researchers have produced contrary evidence. Adams and Hutton (1981), for example, believe torsion to be unimportant in the production of disc degeneration and prolapse. As a result of their experiments they concluded that torsion is resisted primarily by the zygapophysial joint that is in compression and that this is the first structure to yield at the limit of torsion, occurring after about 1 – 2° of rotation in joints with normal discs. They also stated that at the time these joints were damaged the disc was only rotated to between one-third and one-tenth of its maximum angle and bore only a small fraction of the torque required to rupture it. They have suggested that a combination of flexion and lateral bend might be the most likely to produce damage. However, they simulated disc prolapse by subjecting intervertebral joints to hyperflexion (Adams and Hutton 1982).

Liu *et al* (1986) investigated the effect of cyclic torsional loading on intervertebral joints and they also concluded that torsion was unimportant in the initiation of disc degeneration and prolapse, but added that as degeneration progresses, torsion contributes to joint instability.

Shirazi-adl *et al* (1986) constructed an extensive finite element model of an L2-3 motion segment and as a result of their analysis they concluded that torque alone cannot cause the failure of disc fibres but that it could enhance the vulnerability of posterior and posterolateral fibres when the torque acts in combination with other types of loading such as flexion.

An examination of the morphology of the intervertebral joints in relation to their mechanics indicates that the lumbar zygapophysial joints are shaped such that during flexion, when they become distracted, an increase in rotational capacity may well result. This mechanism is demonstrated in Figure 2.1. Thus a working hypothesis, for this part of the thesis, can be expressed as follows. The lumbar spine has a greater ability to twist when in a flexed posture than in the upright posture, suggesting that it is vulnerable to torsional injury when flexed.

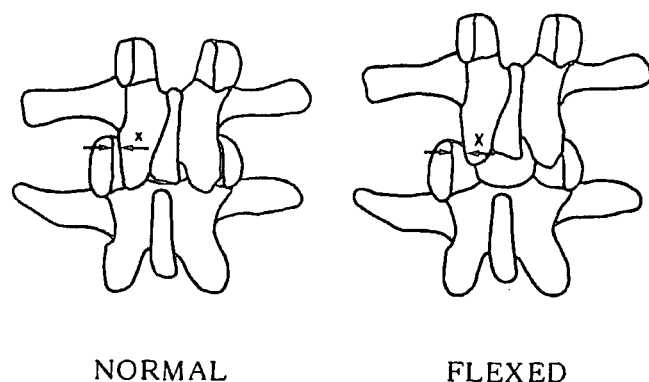

Figure 2.1 — Rotation Available at Lumbar Zygapophysial Joints in the Normal and Flexed Spine

2.3 The CODA-3 Scanner

The CODA-3 Scanner is a commercially available opto electronic device (Mitchelson 1973) (Figure 2.2).

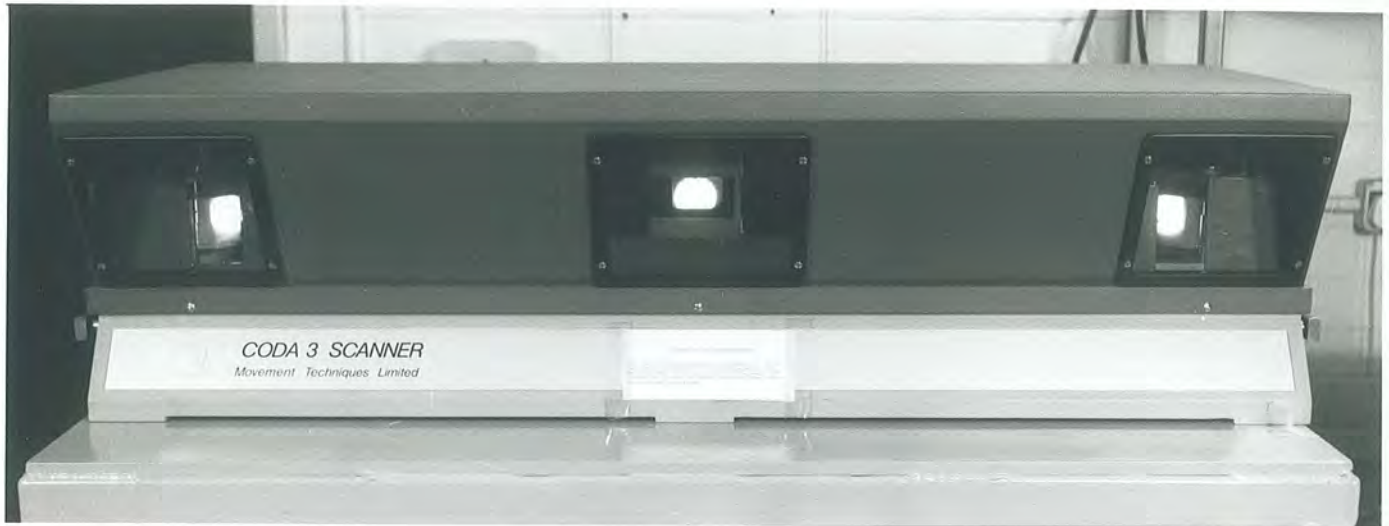

Figure 2.2 — The CODA-3 Scanner

The CODA-3 Scanner sends out three fan shaped beams of light to retroreflective prisms attached to the subject. The light, produced by a Xenon arc lamp, is split and sent out by three octagonal, synchronised rotating mirrors, two mounted on vertical axles and the third on a horizontal axle between the two. When a beam of light crosses a landmark, made up of four retroreflective prisms arranged pyramidally, a brief pulse of light is reflected back along the same path to photodiodes in the scanner unit where it is detected. The orientation of the mirrors when the reflected light is detected enables the position of the marker to be calculated by simple geometry. The orientation of the two mirrors rotating in the vertical plane gives the position in the horizontal plane and the

third mirror rotating on its horizontal axle gives the vertical height, so giving the instantaneous cartesian coordinates of the landmark. Each prismatic marker is uniquely identified by colour. In this way the system can keep track of several markers at once. The complete system is shown in Figure 2.3.

The major, and very restricting problem with the CODA-3 Scanner is the situation referred to as cross-over conflict. When any two markers come within approximately 25mm of each other in a horizontal or vertical plane the machine loses the information about their positions. Markers, therefore, have to be arranged extremely carefully so that movements of interest do not cause conflict.

This problem was tackled by Kelly (1985) in the only previously reported attempt to use the CODA-3 for measuring spinal motion. She placed the markers over the lumbo-sacral spine by mounting them directly onto the skin. However, in this study skin deformation meant that markers had to be attached to marker rigs because of the need to maintain rigid planes between markers in order to calculate three-dimensional rotations.

Two marker rigs were used, each with three prismatic markers attached. The first marker rig was attached over the sacrum and established the reference frame from which the relative movements of the second rig were defined. The second marker rig was attached over the spinous process of L-1, after some trial and error it was attached by means of two elastic straps passing around the subject. A wedge of foam was placed between the base of the marker rig and the subject's back in order to stop the whole rig lifting off upon rotation. The two marker rigs in place on a subject are shown in Figure 2.4.

The unit was set to sample at a frequency of 10Hz over a ten second pe-



Figure 2.3 — The CODA-3 Scanner and Associated Computer Hardware



Figure 2.4 — The Two Marker Rigs in Place on a Subject

riod. This relatively slow sampling rate was judged to be sufficient for measuring movements of the back.

2.3.1 Procedure

Sixteen male subjects aged between 20 and 56 years of age participated in the study. All denied any back pain in the six months prior to the study and none had undergone spinal surgery.

All trials were carried out using the CODA-3 Scanner in the Department of Mechanical Engineering at the University of Newcastle upon Tyne.

The subjects were positioned in a metal standing frame with adjustable plastic pads against their anterior superior iliac spines. This acted to align the subject with the coordinate axes of the measurement system. Hip motion was limited by means of a belt strapped firmly around the buttocks in order that the markers did not cause conflict or pass out of the field of view. Ranges of maximal voluntary flexion and extension were first measured in all subjects.

During the ten second period when data were recorded each subject had to first flex forwards as far as possible, with their hands by the sides, before returning to the upright position and then extending maximally before returning to the upright position. The procedure was then repeated, assuming satisfactory data had been collected in the first instance, with the subject first extending then flexing.

Subjects remained secured in the frame for the measurement of maximum voluntary axial rotation. For this the subjects crossed their arms over their chests and twisted maximally to right and then left. The measurement was then

repeated with the subject twisting first to left and then right (Figure 2.5).

Rotation was then assessed in two seated postures which were intended to induce a certain degree of sagittal flexion.

In the first the subject was seated on a stool with knees flexed. In order to define the zero position for any flexion that may have occurred in the seated posture subjects started the sequence standing upright, they then sat down and twisted maximally to each side (Figure 2.6). Since some degree of flexion was required, subjects were simply asked to sit in a comfortable and relaxed way as this inevitably meant the resulting posture was somewhat slumped.

The second posture required the subject, upon sitting down, to raise his legs onto another stool so that his knees were now extended. Rotation was recorded as before.

The measurements were recorded after the subject had practiced each new movement. A measurement was repeated if marker conflict caused a loss of data.

2.3.2 Data Analysis

From the three-dimensional coordinates of the prismatic markers for the 100 data points in each measurement period the relative rotations between the two marker rigs were calculated as the subject moved to give angles of flexion-extension, lateral bend and axial rotation. Subsequent to each measurement a graphical presentation of the three angles was produced against time.

2.3.3 Results

All 16 subjects produced results for ranges of flexion and extension. However,



**Figure 2.5 — A Subject Positioned in the Standing Frame Performing
Axial Rotation**



Figure 2.6 — A Subject Performing Axial Rotation in the First Seated Posture

only 12 of the 16 gave a full set of data for the measurement of axial rotation in the standing and seated positions. The remaining four were excluded for one of three reasons:

1. Two subjects were excluded because of a combination of cross-over conflict problems and failure of the CODA-3 hardware.
2. One subject was found to be too short to sit on the stool used in the trial without first adopting an unnatural posture which affected his subsequent movements.
3. One subject failed to display any flexion in the two seated postures and complained of the sensation of falling backwards. Since the aim of the experiment was to examine rotation in a state of flexion he was excluded.

The results for the maximum voluntary ranges of flexion and extension are shown in Table 2.1 compared with the results obtained by biplanar radiography in a study of normal young males (Pearcy 1985). The two seated postures were found to have significantly increased the subjects' anterior flexion from the standing position. Taking the subjects' standing posture to be zero flexion and maximum flexion as the value achieved in the previous determination of ranges of flexion and extension then the first posture induced, on average, some 40% of a subject's maximum flexion. The second seated posture, with feet raised, induced about 65% of maximum flexion. It was found that expressing the amount of flexion induced as a percentage of maximum rather than absolute angular values, helped reduce the considerable individual variation present.

Movement	CODA-3	3-D X-RAY
	mean (S.D.)	mean (S.D)
Flexion	55.2 (11.8)	51 (9)
Extension	21.4 (7.70)	16 (6)
Total	76.6 (12.0)	67 (11)
n	16	11

Table 2.1 — Flexion and Extension Measured by CODA-3 and by 3-D X-RAY

Typical plots obtained for a subject's axial rotation in the three postures are shown in Figures 2.7, 2.8 and 2.9. The plot showing maximum voluntary axial rotation in the standing position, Figure 2.7, shows the subject twisting first to the right and then the left. Some coupled flexion is demonstrated as is some left bend with right twist although no right bend is apparent with left twist. The two plots for the seated postures (Figures 2.8 and 2.9) show clearly the considerable flexion that each posture induced, this being maintained throughout the test period.

When the results for maximum voluntary axial rotation in each of the three postures were considered together an increase in rotational ability was found to be present in both of the flexed postures (Figure 2.10).

This was found to be statistically significant ($p < 0.05$, Students' t-Test) between the standing and most flexed seated postures. The standard deviations about the mean values of axial rotation are seen to increase at each posture

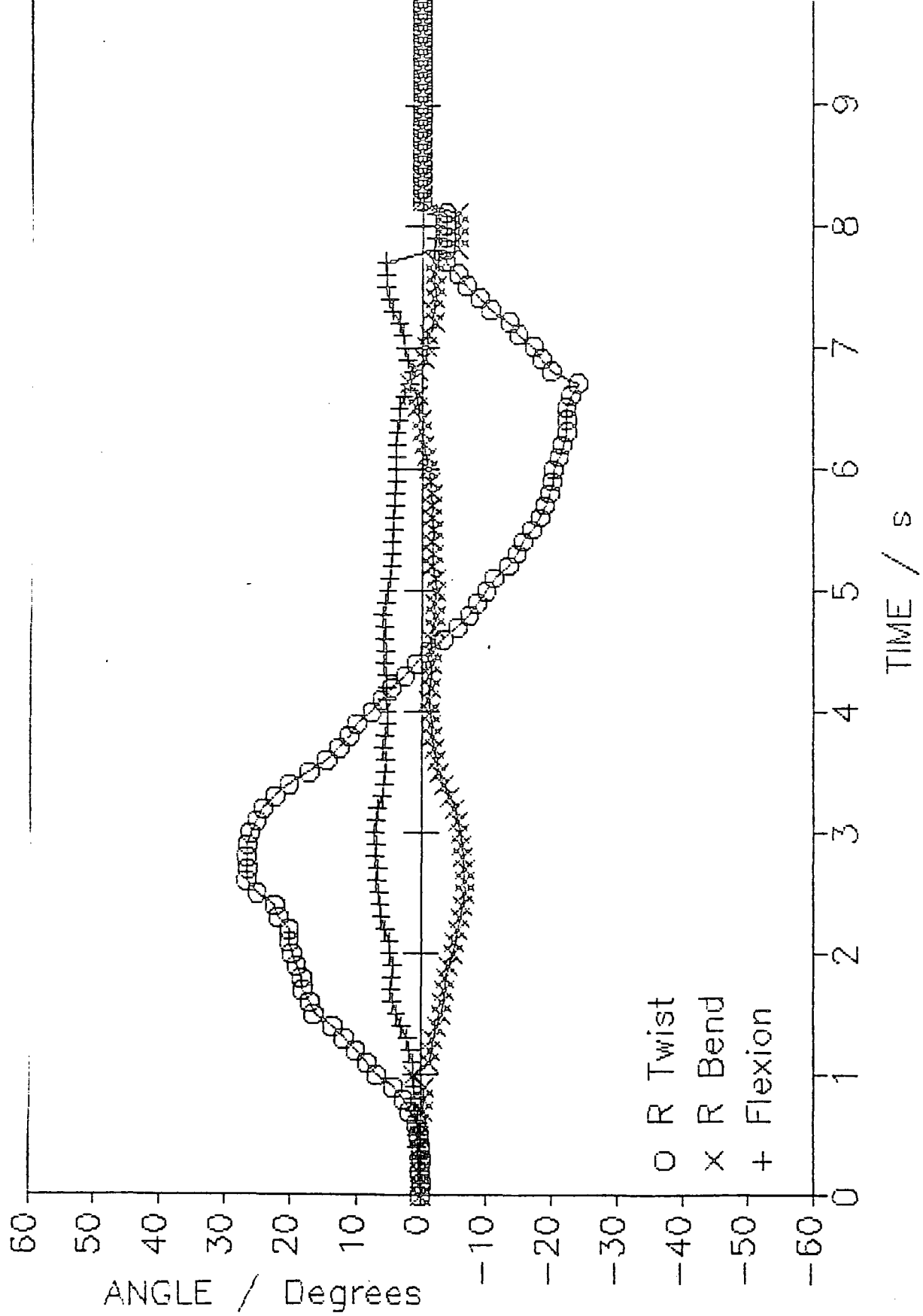

Figure 2.7 — A Plot of a Subject Twisting whilst Standing

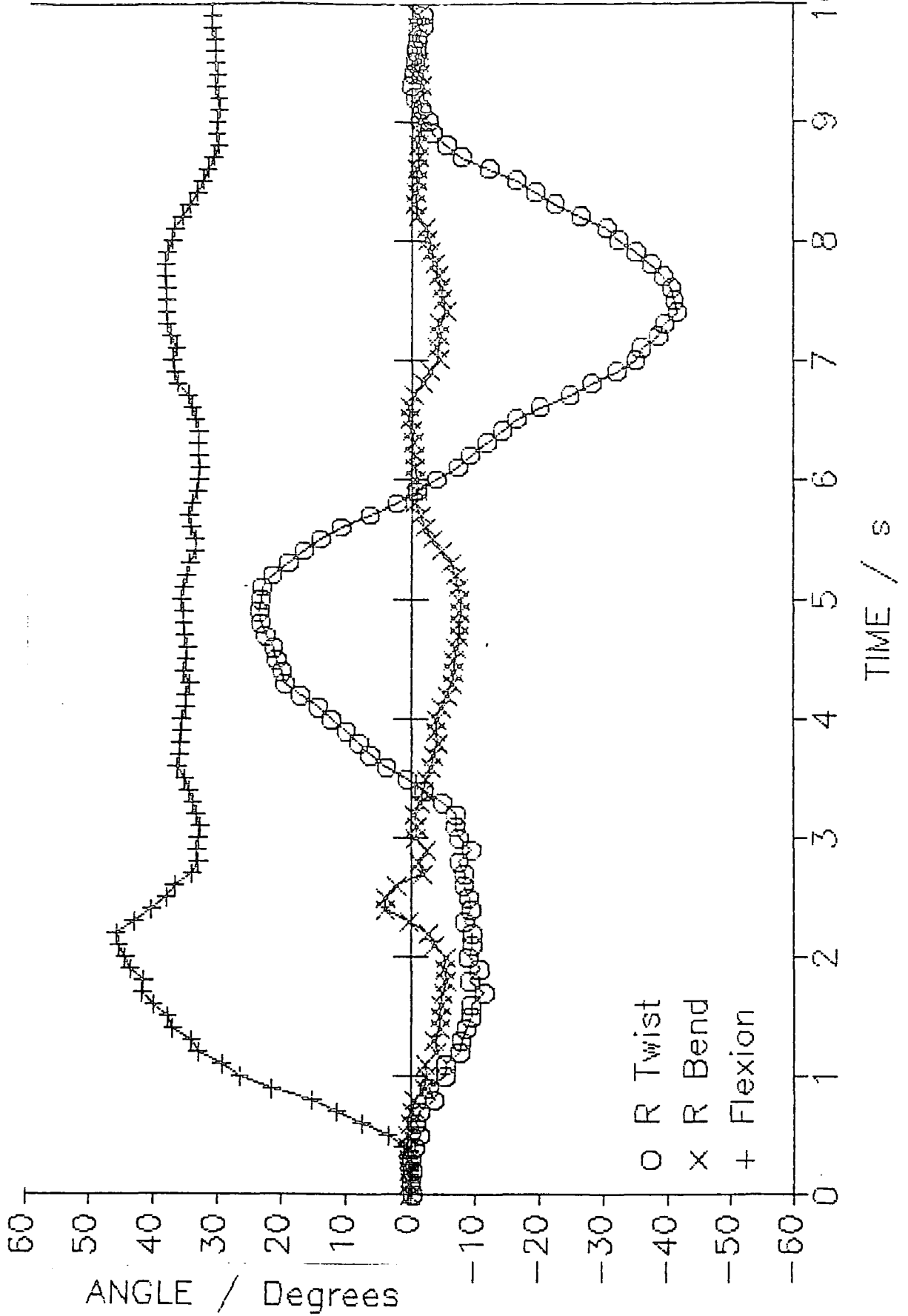

Figure 2.8 — A Plot of a Subject Twisting whilst Sitting

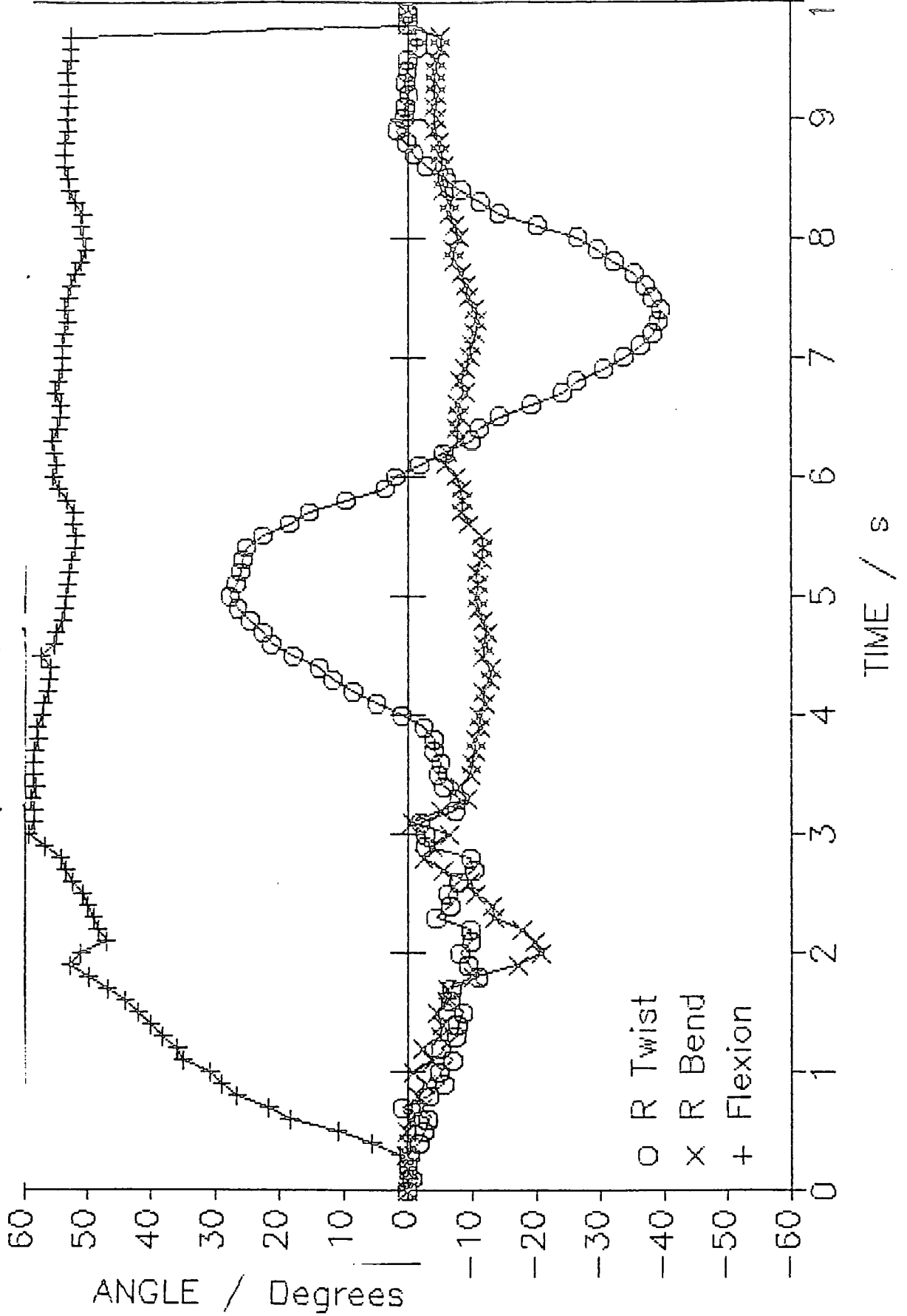

Figure 2.9 — A Plot of a Subject Twisting whilst Sitting Flexed

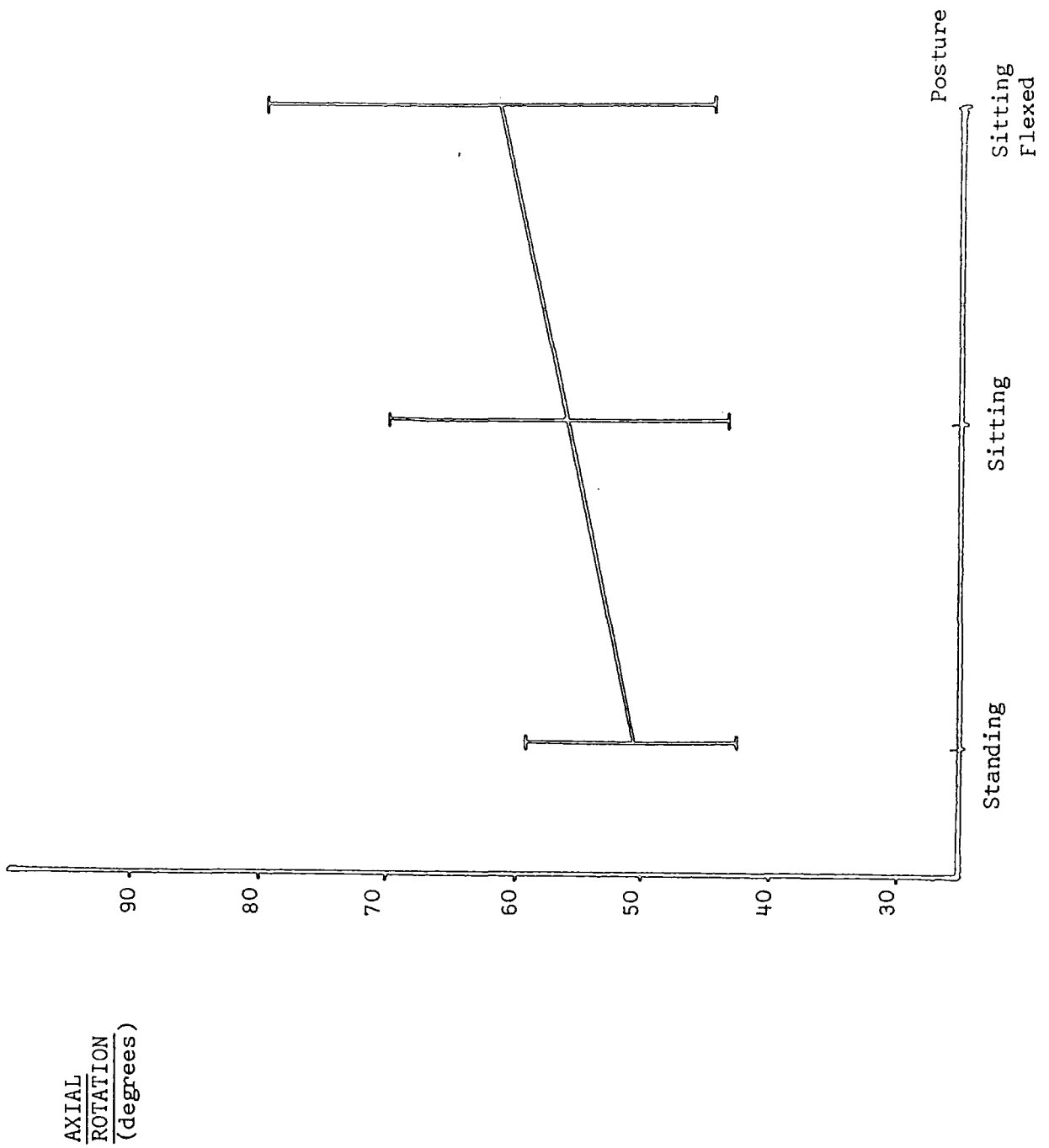

Figure 2.10 — Mean Axial Rotation Produced in the Three Postures Marked with their Standard Deviations

(Figure 2.10), this is due to the variation in the amount of flexion produced by each subject by the two seated postures (Figure 2.11).

2.4 Discussion of the CODA-3 Trial

The aim of this study was twofold; first to assess the CODA-3 Scanner as a clinical measurement tool and second to investigate the possible role of torsion when combined with flexion in the production of damage to the intervertebral disc. The results indicate that rotational ability may be increased when in a flexed posture. However, the technical limitations of the CODA-3 Scanner must cast doubt on the data produced. Such were the problems with the system that it seems dubious as to whether the CODA-3 Scanner has any place in the research setting, let alone in clinical practice.

The main problems with the system stem from its inability to cope with cross-over conflict. This necessitated the attachment of the markers on clumsy outriggers which required careful set up by the operator and movements having to be repeated several times before satisfactory data had been collected, even then it was very rare to collect a full set of data points. To add to this the CODA-3 hardware proved far from reliable being prone to fail frequently. The overall result was a time-consuming and unreliable procedure. This was confirmed in a recent study comparing the CODA-3 Scanner to a computerised three-dimensional television system (VICON) (Pearcy *et al* 1987c).

When the limitations of the CODA-3 Scanner as a clinical measurement tool became apparent a search began for other non-invasive, three-dimensional devices that might be applicable for the kinematic measurement of spinal motion. Research suggested that an electro-magnetic device developed by the aerospace

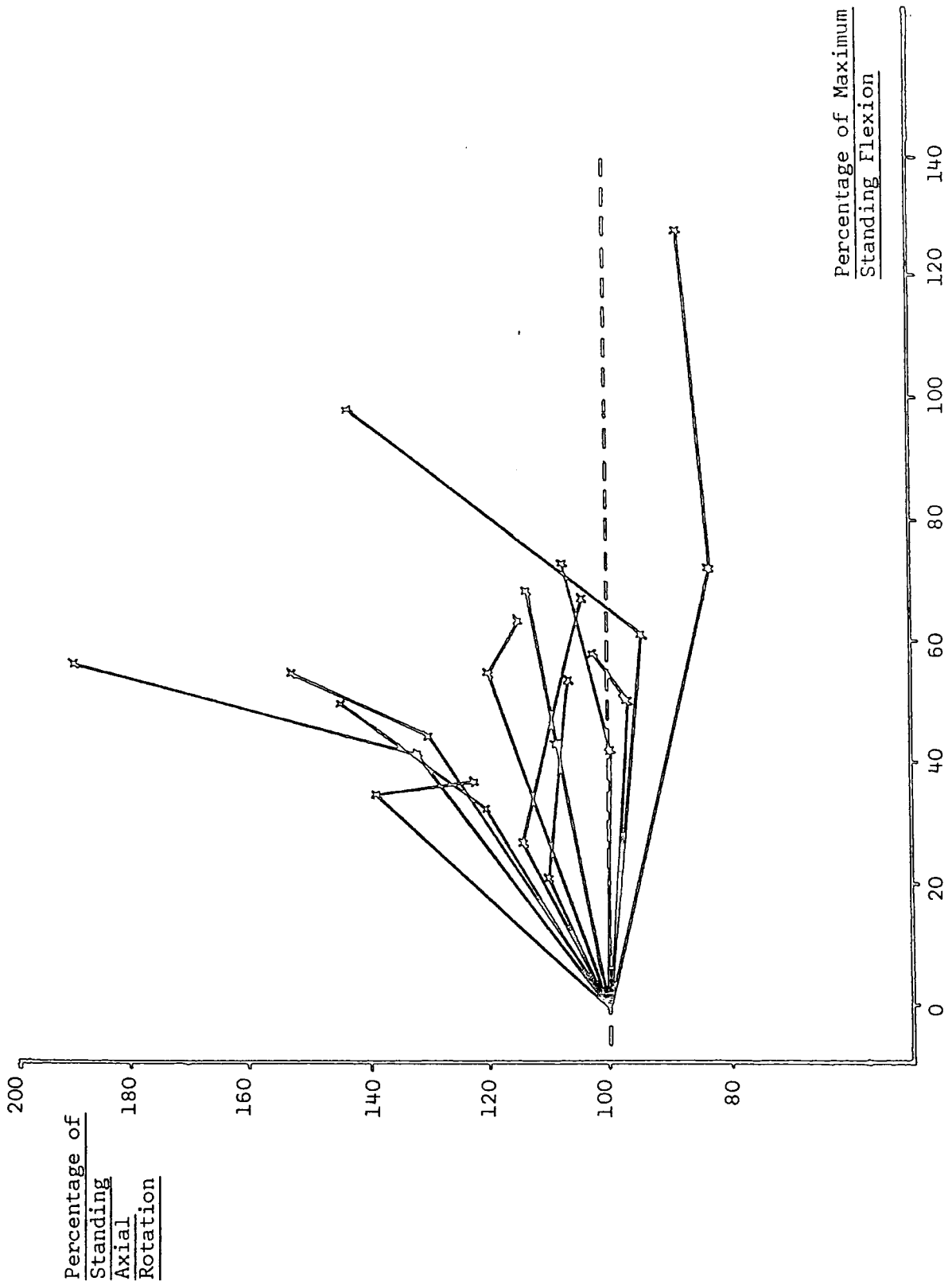

Figure 2.11 — A Graph Showing the Relationship between Axial Rotation and Flexion

industry in the U.S.A. might be equal to the task.

2.5 The 3SPACE Isotrak

The 3SPACE Isotrak is an electro-magnetic device for the measurement of the position and orientation of a sensor in space. It consists of an electronics package, containing the hardware to drive the system and the primary software for the control of data acquisition, to which are attached a source module and a sensor (Figure 2.12). The source, the larger of the two modules, generates a low-frequency magnetic field which is detected by the sensor. The sensor monitors the magnetic field and the electronics package calculates the position and orientation of the sensor relative to the source with full six degrees of freedom for three-dimensions. The electronics package is linked to a personal computer which controls the 3SPACE operation and data storage through specially written applications software.

An *et al* (1988) suggested that the 3SPACE Isotrak could have applications for kinesiologic study and prior to this Buchalter *et al* (1986) first suggested the device as a possible tool for measuring spinal motion and reported preliminary trials. Buchalter *et al* (1989a and 1989b) have recently published a more detailed account of their technique and have also described its application to a study of lumbar brace immobilisation of the spine. The same research group have also used the 3SPACE Isotrak to determine the effects of spinal flexion and extension exercises on low back pain and spinal mobility of chronic back pain patients (Elnaggar *et al* 1988a and 1988b). However, they have only used the system to record indices of motion statically at the extremes of movement. To the best of our knowledge no one has yet used the 3SPACE Isotrak to record kinematic

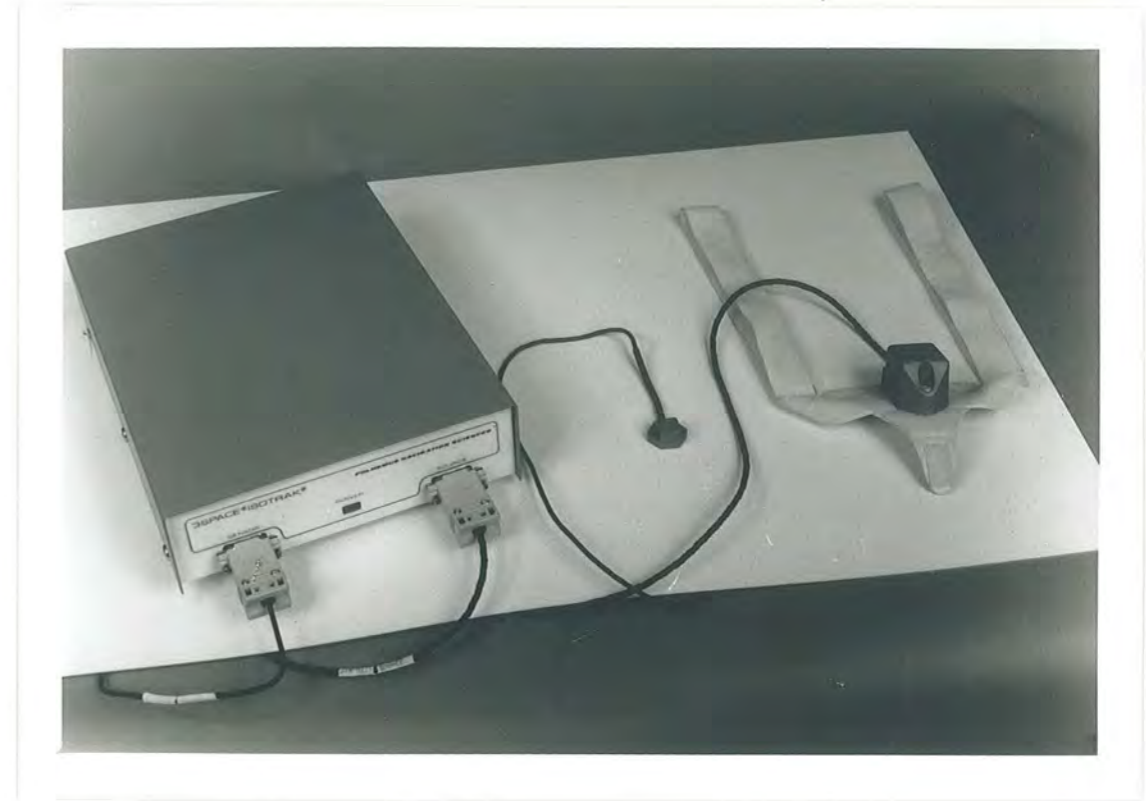

**Figure 2.12 — The 3SPACE Isotrak showing the Electronics Box,
Source and Sensor**

movement of the spine.

Movements are obtained by comparing the output from the sensor at discrete time intervals controlled from the personal computer. For the measurement of back movements rotations alone are measured and so the data acquired from the 3SPACE at each time interval consists of the 3x3 matrix of direction cosines for the orientation of the sensor relative to the source. This matrix is then analysed to give three independent rotations of the back relative to the pelvis based on the definitions of Pearcy *et al* (1987b) which is a modification of that proposed by Benati *et al* (1980). Back movements are quoted as rotations from the relaxed

upright position to provide a standard starting point.

The resolution, accuracy and repeatability of the 3SPACE system had to be assessed before any subject trials could be undertaken. Following this a number of preliminary trials were carried out to establish the suitability of the 3SPACE system for the measurement of spinal motion. Firstly, suitable attachment of the source and sensor to the subject had to be achieved, this included an appraisal of techniques used to identify anatomical landmarks, variation in site of placement of the source and sensor and the effects of skin distraction. Secondly, the repeatability and day to day variation in the ability of subjects to perform movements had to be assessed.

2.5.1 Resolution of the 3SPACE System

The resolution of the 3SPACE system was assessed by mounting the source and sensor securely on a solid wooden beam at approximately the same distance they would be apart when mounted over the sacrum and first lumbar vertebra respectively. Wood was used since the 3SPACE system relies on a magnetic effect and any mass of metal in close proximity may affect its accuracy. Data were recorded over a ten second period, this being repeated five times. The Root Mean Square variation for each of the three movement planes (flexion/extension, lateral bend and axial rotation) for each of the five trials was $< 0.05^\circ$. This represents the 3SPACE system error.

The procedure was repeated while the beam, to which the source and sensor were mounted was moved randomly in space. The system error increased slightly but remained $< 0.1^\circ$.

2.5.2 Accuracy of the 3SPACE System

To assess the accuracy with which the 3SPACE system measures a known angle four wooden wedges of different inclination had their angles measured both by the 3SPACE system and by a precision optical clinometer. The clinometer was capable of measuring an angle to within 5 seconds of arc.

Each wedge was, in turn, secured to a wooden base to which was also attached the source. Data were collected from the 3SPACE system first with the sensor on the flat base to establish the zero position, then with it placed on the angled surface of the wedge. This was repeated five times for each wedge. The clinometer was then employed to determine the true inclination of each wedge, the final value being an average of three readings. The results are displayed in Table 2.2.

Wedge	Mean Clinometer Reading (°)	Mean 3SPACE Reading (°)	Error (°)
1	8.674	7.649	-1.025
2	18.045	16.694	-1.346
3	26.852	25.019	-1.833
4	34.572	32.165	-2.408

Table 2.2 — Clinometer versus 3SPACE reading

Regression analysis showed that accuracy reduces linearly as the angle increases according to the equation:

$$y = 1.056x + 0.509$$

where y =true angle and x =3Space reading (Figure 2.13).

2.5.3 Repeatability of Measurements

The repeatability of the 3SPACE system was assessed using a specially constructed wooden rig. The source was mounted on one arm of a hinged beam and the sensor on the other. The hinge was moved to a set position; the source and sensor being mounted in such a way that this movement represented movement in the flexion/extension plane. This was repeated three times. The procedure was then carried out twice more with the source and sensor positioned such that lateral bend and axial rotation were simulated. The results are displayed in Table 2.3. A mean R.M.S. error of 0.091° was obtained which was of the same order as the system error. These trials indicated that the total R.M.S. error encountered in measuring angles with this device was less than 0.2° .*

Movement	R.M.S. Error ($^\circ$)
Flexion-extension	0.079
Lateral Bend	0.127
Axial Rotation	0.066

Table 2.3 — Repeatability Trials

2.5.4 Attachment of the Source and Sensor to Subjects

The major problem with any non-invasive system, such as this, is the attachment of the measurement devices to the subject and ensuring that once attached they record the actual movement of the spine.

*These studies were conducted with uniplanar movement. To assess the repeatability of the measurements when rotations occurred in more than one plane, these tests were repeated with the sensor additionally rotated in a plane other than that under examination. The results showed that the accuracy of measurement in each plane was not affected by rotations in the other planes.

CALIBRATION PLOT

3SPACE ISOTRAK

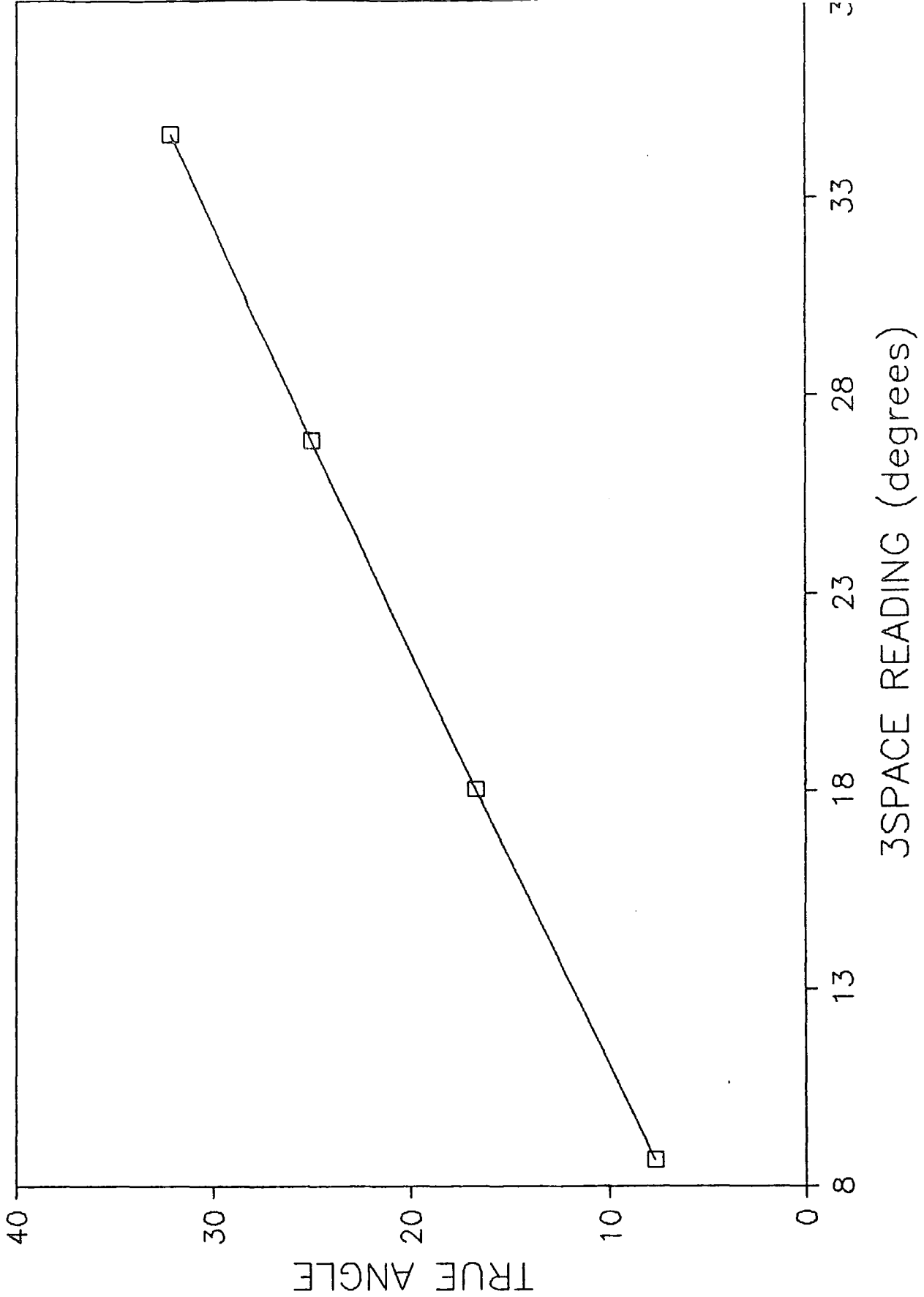

Figure 2.13 — Regression Line for Clinometer versus 3SPACE reading

In this trial the source module provides the reference from which movements of the sensor are determined. In the anatomical framework the lumbar spine moves relative to the stationary sacrum. It was, therefore, convenient to attach the source to the sacrum and the sensor to the lumbar spine. A moulded plastic pad was constructed to which the source was attached by means of plastic screws. This pad was shaped such that it sat neatly over the sacrum. An adjustable belt, secured firmly around the subject, held the source in place.

The satisfactory attachment of the sensor proved more difficult to achieve. In order to determine lumbar spinal motion the sensor needed to be secured over the spinous process of L-1, marking the upper end of the lumbar spine. Burton (1987) has recently questioned the techniques used to identify various spinal landmarks in other non-invasive measurement studies. He reports that most authors simply state that, for example, the spinous process of L-1 was identified by palpation. McConnell *et al* (1980) have shown how even trained personnel have difficulty in correctly locating spinal segments.

Haley and colleagues (1986) report that the spinous process of L-5 lies at the intersection of a line joining the dimples of Venus, a name given to the two indentations formed by the posterior superior iliac spines. Hart and Rose (1986), however, state that it is the spinous process of S-2 that lies at this point. Given this confusion it was decided to adopt the method recently used by Burton (1987). He identifies the spinous process of L-4 as being at the bisection of a line joining the highest points of the iliac crests, based on the earlier findings of MacGibbon and Farfan (1979). Having identified the spinous process of L-4 in this manner the spinous process of L-1 was then found by counting up the spinous processes. In some subjects this was made easier by getting the subject to flex slightly,

making the spinous processes more prominent.

The sensor is relatively light and so it was possible to attach it directly to the skin with the use of double-sided tape. However, one of the major concerns with non-invasive studies such as this one is that the movement of the skin, and hence the sensor attached to it, may not reflect the actual intervertebral movement that is occurring underneath it. Stokes (1977) secured steel markers to the skin overlying lumbar spinous processes and then measured sagittal flexion radiographically and compared the movements of the skin markers to those of the underlying vertebrae, the markers were found to agree with intervertebral markers to within about 10%. No such assessment has been made on the effects of torsional and lateral movements of the lumbar spine. No anatomical data could be found to clarify the attachment, or non-attachment of skin to underlying spinous processes.

Burton (1987) is of the opinion that, considering sagittal plane movements, accurately placed skin marks will maintain an approximate relation to vertebrae during movement. In this study, where whole lumbar movement is being considered as opposed to segmental mobility, the attachment of the sensor to the skin can certainly be considered sufficiently accurate to give a measure of lumbar movement.

Various means of attachment of the sensor to the skin were tried before a satisfactory arrangement was arrived at. Initially the sensor was attached to the skin with a small square of double sided tape, this proved insufficient to hold the sensor in place during anything but the smallest movements. The arrangement finally chosen was to use two strips of tape, approximately 2.5 cm long, attached

to the sensor in the shape of a diagonal cross which was then secured over the spinous process of L-1.

Preliminary trials with this set up revealed adequate results when measuring sagittal plane movements but on attempting to measure axial rotation deformation of the skin was found to have a significant effect. As a subject performs axial rotation to the right, for example, the skin overlying the lumbar spine is drawn around the body in the opposite direction. This resulted in a description of movement totally opposite to that actually occurring in the vertebral column. This situation was resolved by placing a strap over the sensor and around the trunk of the subject. This kept the sensor positioned over the L-1 spinous process to a much greater degree. Figure 2.14 shows the source and sensor in place on a subject.

2.5.5 Variation in Sensor Placement

Two subjects took part in a trial conducted to determine the effects of placing the sensor either higher or lower on the spine than the estimated position of L-1.

The spinous process of L-1 was identified in each subject by the method mentioned previously. Marks were then inked on the skin overlying L-1 and at points 1 and 2cm above and below this. The subject then performed maximum voluntary flexion and extension, lateral bend and axial rotation with the sensor secured over each of these five points in turn. The source remained secured in the same position throughout the whole of the procedure.

It is appropriate at this point to discuss exactly how the three movements were performed and measured as the basic procedure was the same throughout

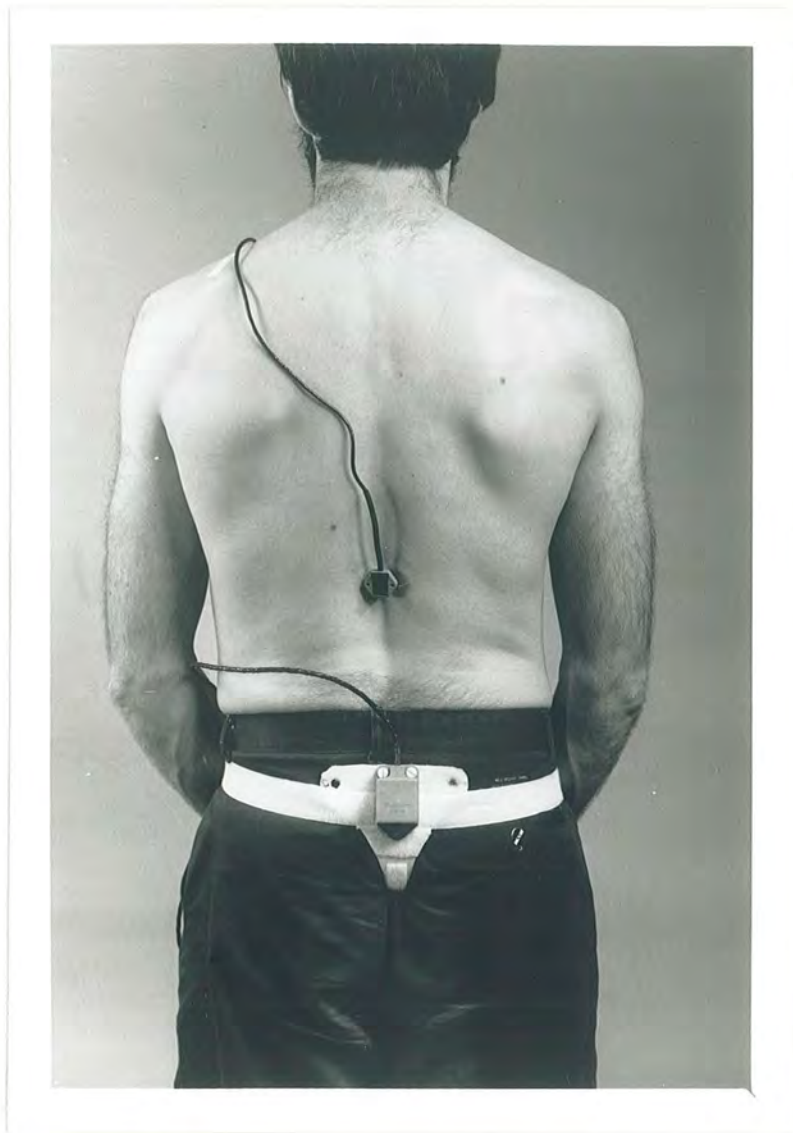

Figure 2.14 — The Source and Sensor in Place on a Subject

all the measurements conducted for this thesis. After the source and sensor had been attached, the subject would first perform maximal flexion and extension, the start of the measurement period being signalled by a an audible cue from the computer, as the subject performed the movement the operator would count out the ten seconds in order that the subject could perform his movement smoothly.

Lateral bend was performed similarly with the subject attempting to stretch the appropriate hand down each leg as far as was possible. Axial rotation was performed with the subjects' arms crossed over their chests.

The results for the maximum ranges of motion that the two subjects achieved for each of the sensor positions are shown in Table 2.4. It demonstrates that movements were not necessarily increased or decreased by simply moving the sensor up or down the spine, as may have been expected. For example it can be seen that when subject RH performed maximal axial rotation with the sensor 1 and 2cm higher and lower than L-1 all four trials resulted in a decrease in actual twist achieved. However, in general a trend can be seen throughout these results that does indicate, especially with the sensor displaced by 2cm either side, increased or decreased movement dependent on the location of the sensor.

The significance of this trial is arguable. Although every care was taken to ensure the correct location of L-1 there is no guarantee that it was correctly identified, the only way to test the accuracy of location would have been to conduct a radiographic study, which unfortunately was not possible. Secondly it could be argued that an operator would be unlikely to misplace the sensor by plus or minus 1 or 2cm but by plus or minus one spinous process. However, the distance between lumbar spinous processes is of the order of 2cm and lumbar spinous processes are sufficiently large that the sensor could easily be placed above or below the central point. Despite now knowing the effect of misplacing the sensor it is obviously not possible to be able to determine whether this actually occurred, or not, from an examination of a subject's data. However, these data do provide a means of quantifying the error associated in the assessment of how repeatably an observer was able to identify the spinous process of L-1 (see section 2.5.7).

Subject	Sensor Position (cm)	Flexion-Extension (°)	Lateral Bend (°)	Axial Rotation (°)
RH	+2	+1.52	+7.45	-0.69
	+1	-3.46	+2.1	-1.86
	-1	-10.28	-1.37	-4.17
	-2	-15.8	-8.69	-1.41
MP	+2	+18.51	+10.61	+7.97
	+1	+10.31	+2.01	-8.41
	-1	-12.9	-2.49	-14.77
	-2	-9.69	-7.21	-12.19

Table 2.4 — The Effect of Varying Sensor Placement Showing the Change from the L-1 Position for each Movement

2.5.6 Movement Repeatability

In a clinical setting it is obviously desirable to be able to conduct as few repeats of a movement as possible, ideally to measure it only once. In order to ensure that this would be acceptable, three subjects each performed maximal voluntary flexion and extension, lateral bend and axial rotation five times in succession. They then performed extension and flexion, lateral bend, starting to the opposite side, and axial rotation, starting to the opposite side five times in succession. Figures 2.15, 2.16 and 2.17 demonstrate how consistently a subject was able to perform a movement in terms of the pattern of movement. The techniques used to produce these plots are discussed later in the thesis.

The standard deviations that were produced in each set of repeated movements

X-AXIS ONE DIVISION = 1 Second
Y-AXIS ONE DIVISION = 10 Degrees

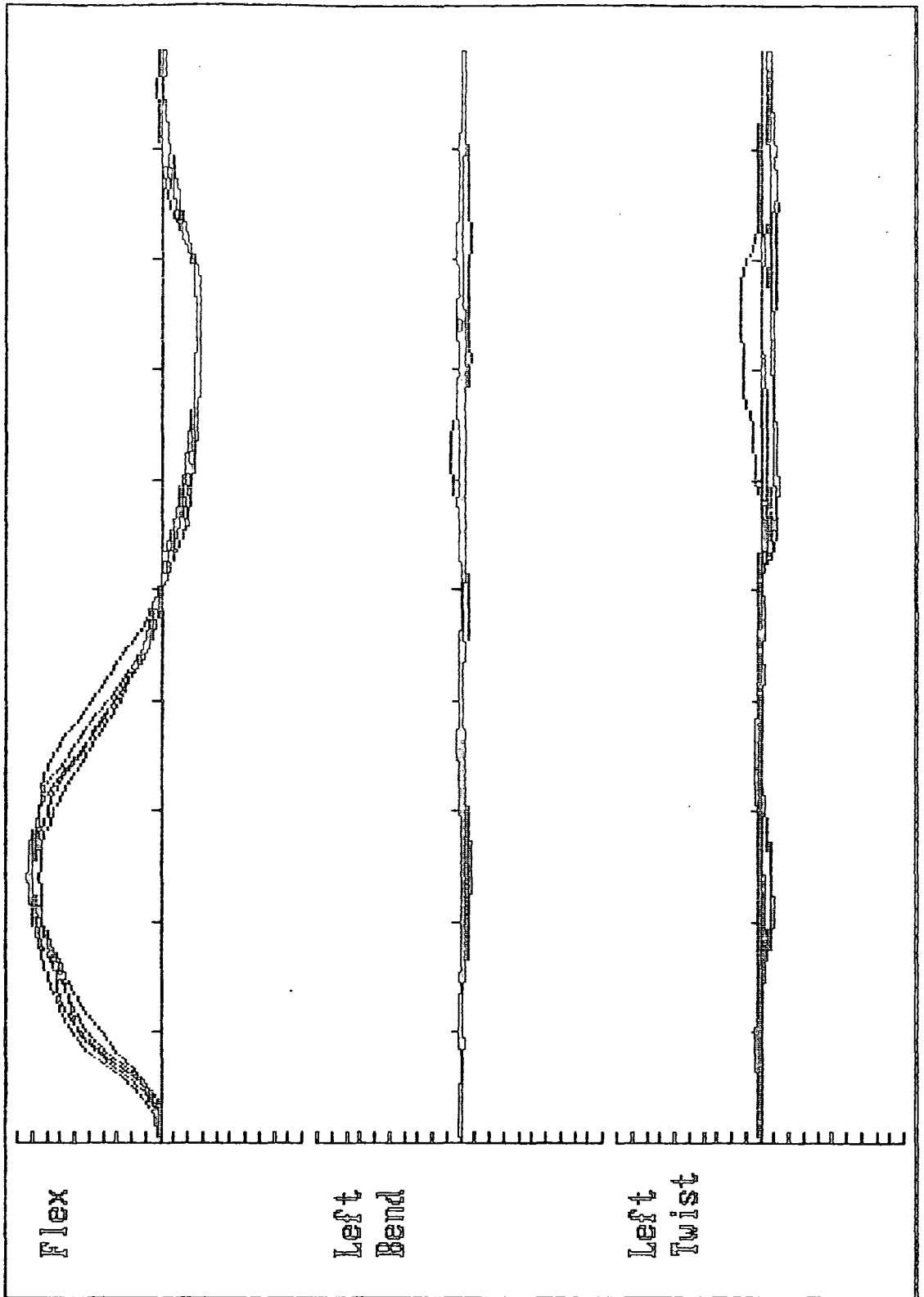

Figure 2.15 — A Subject Flexing and Extending Five Times in Succession

X-AXIS ONE DIVISION = 1 Second
Y-AXIS ONE DIVISION = 10 Degrees

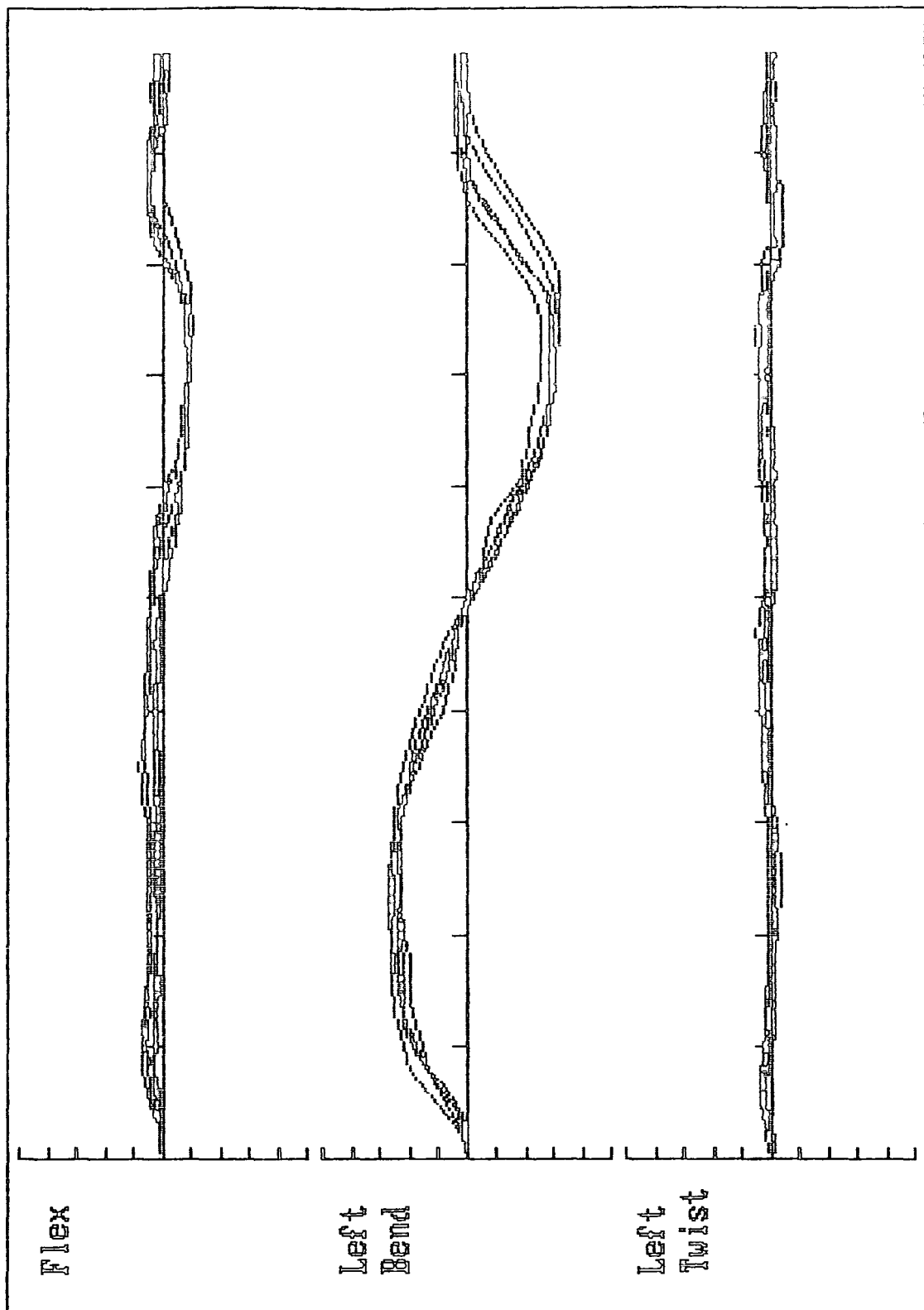

Figure 2.16 — A Subject Performing Lateral Bend Five Times in Succession

X-AXIS ONE DIVISION = 1 Second
Y-AXIS ONE DIVISION = 10 Degrees

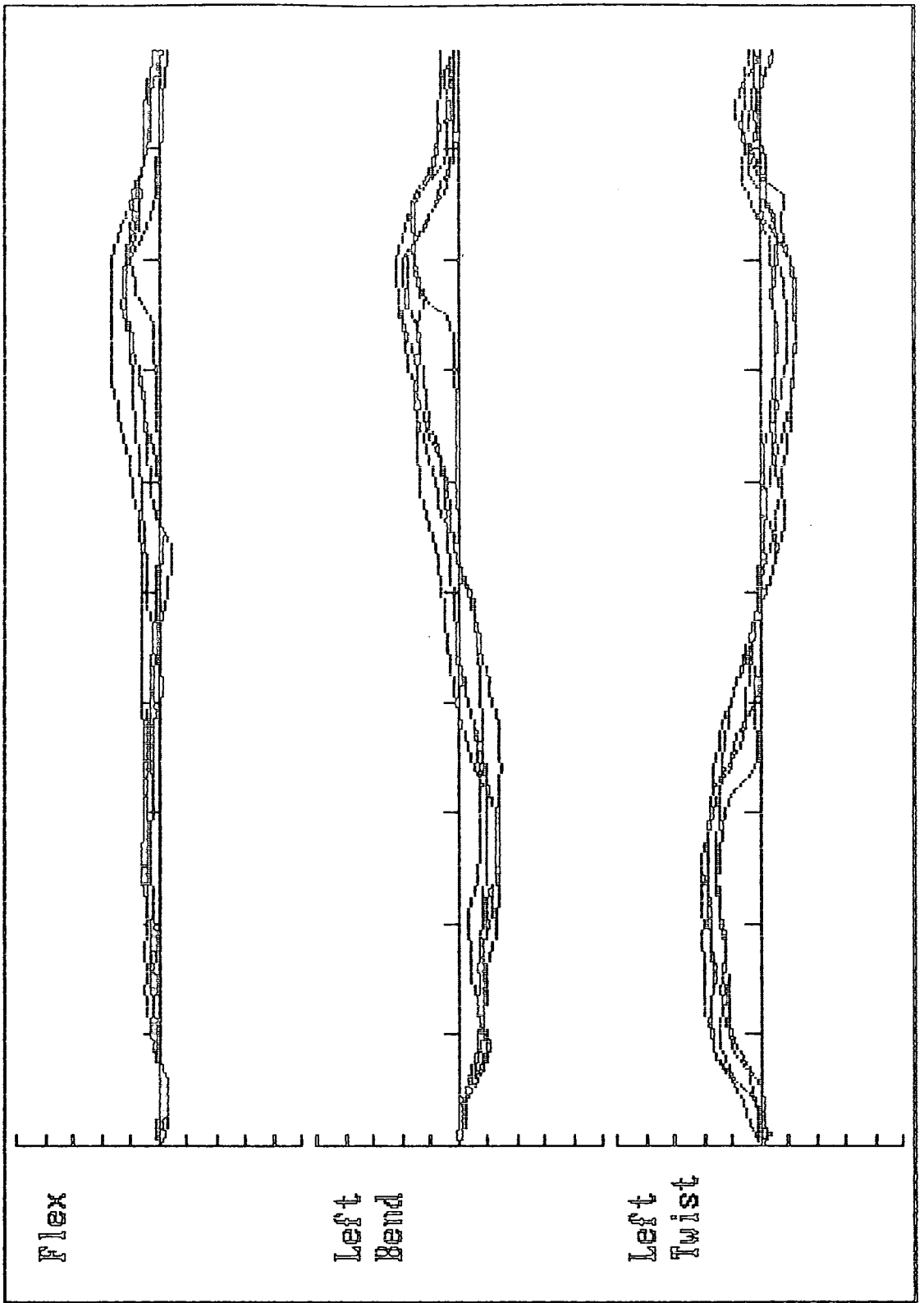

Figure 2.17 — A Subject Performing Axial Rotation Five Times in Succession

are displayed in Table 2.5. Standard deviations ranged from 0.39° to 3.92° with a mean of 1.84° . This value was judged to be sufficiently small that if a subject were to repeat a movement twice only, starting in opposite directions, representative results would be obtained. Figures 2.18, 2.19 and 2.20 show the same five movements as Figures 2.15, 2.16 and 2.17 but expressed in terms of the mean and ± 2 standard deviations (representing the 95.4% confidence levels). They show that only this small variation is present throughout the whole of the movements.

2.5.7 Day to Day Variation

In order to determine the effects of day to day variation in the ability of an individual to perform a movement two subjects had their movements measured on five consecutive days. Each measurement session took place at the same time of day, in order to eliminate diurnal effects. The spinous process of L-1 was identified at the start of the first session and was then marked with indelible ink. After each measurement period the ink mark was covered with tape to ensure it remained until the following day. By doing this it was ensured that the sensor was located in exactly the same position on each occasion thus eliminating any variation due to sensor placement. The standard deviations for each set of 5 repeated movements for the two subjects are displayed in Table 2.6. Standard deviations are used, rather than coefficients of variation, since these angular values allow a direct comparison with the 3SPACE system error.

Subject	Movement	Flexion or L. Bend or L. Twist (°)	Extension or R. Bend or R. Twist (°)
RH	Flexion-Extension	2.97	1.03
	Extension-Flexion	3.20	2.26
	L.bend-R.bend	1.37	2.23
	R.bend-L.bend	2.02	1.86
	L.twist-R.twist	2.23	3.11
	R.twist-L.twist	1.68	1.81
MP	Flexion-Extension	3.05	2.35
	Extension-Flexion	1.22	2.56
	L.bend-R.bend	0.46	0.68
	R.bend-L.bend	0.57	0.79
	L.twist-R.twist	3.92	1.93
	R.twist-L.twist	2.39	2.41
JB	Flexion-Extension	1.8	2.08
	Extension-Flexion	1.52	2.73
	L.bend-R.bend	0.39	1.38
	R.bend-L.bend	0.94	1.03
	L.twist-R.twist	1.57	2.98
	R.twist-L.twist	0.80	0.96

Table 2.5 — Standard Deviations from Five Repeated Movements in
Three Subjects

X-AXIS ONE DIVISION=1 Second
Y-AXIS ONE DIVISION=10 Degrees

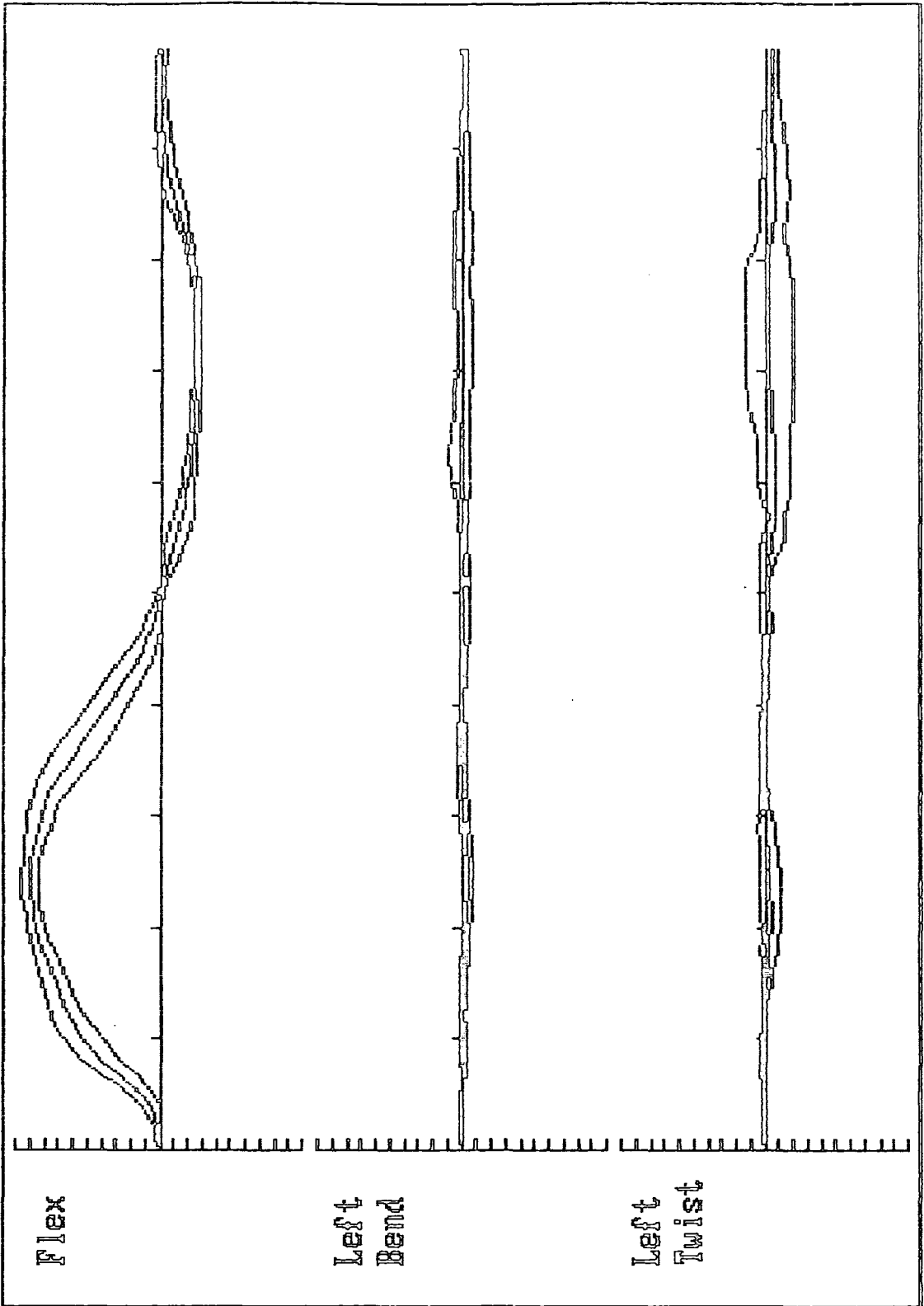

Figure 2.18 — Mean and ± 2 Standard Deviations of a Subject Performing Flexion and Extension Five Times in Succession.

X-AXIS ONE DIVISION=1 Second
Y-AXIS ONE DIVISION=5 Degrees

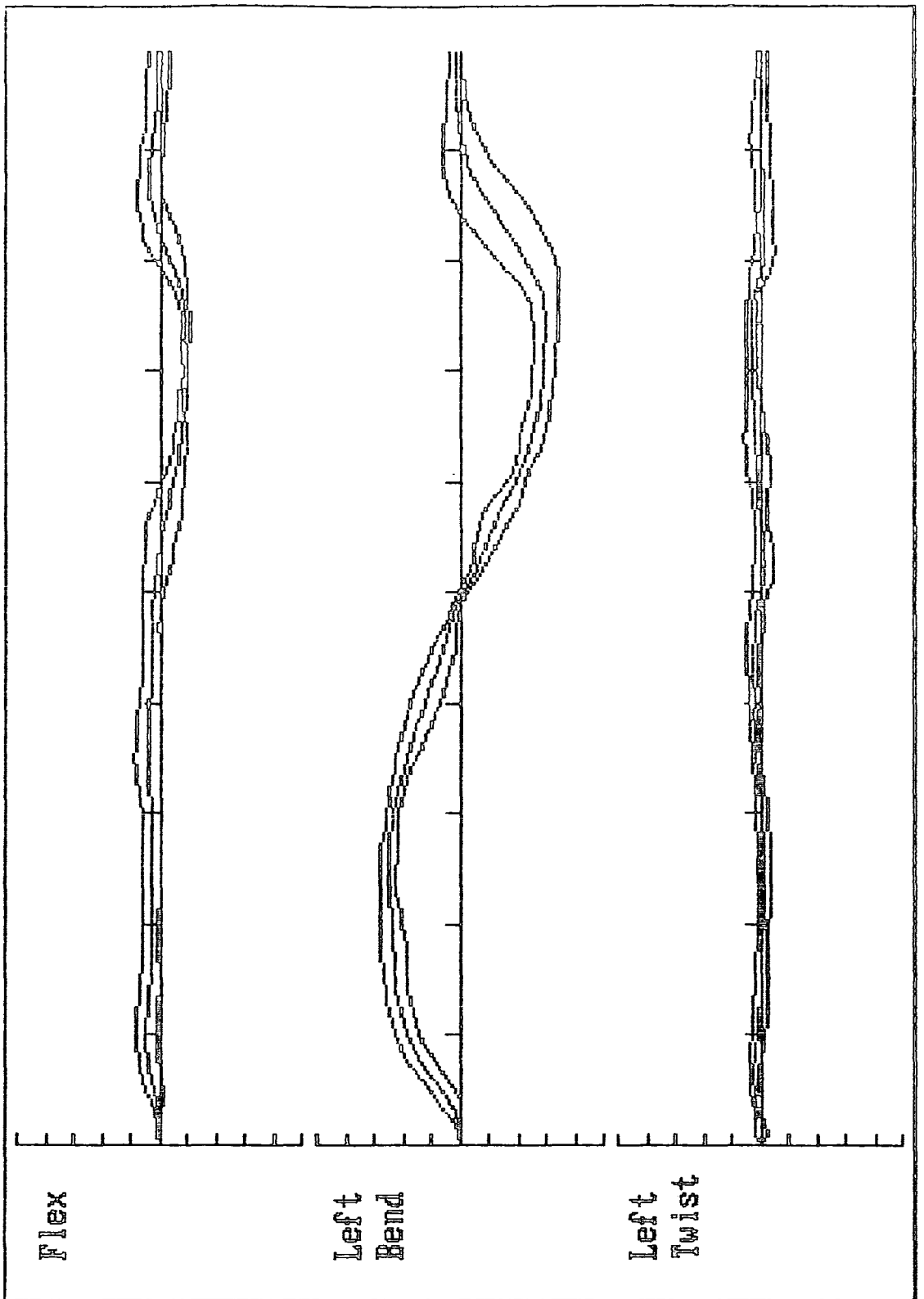

Figure 2.19 — Mean and ± 2 Standard Deviations of a Subject Performing Lateral Bend Five Times in Succession.

X-AXIS ONE DIVISION=1 Second
Y-AXIS ONE DIVISION=5 Degrees

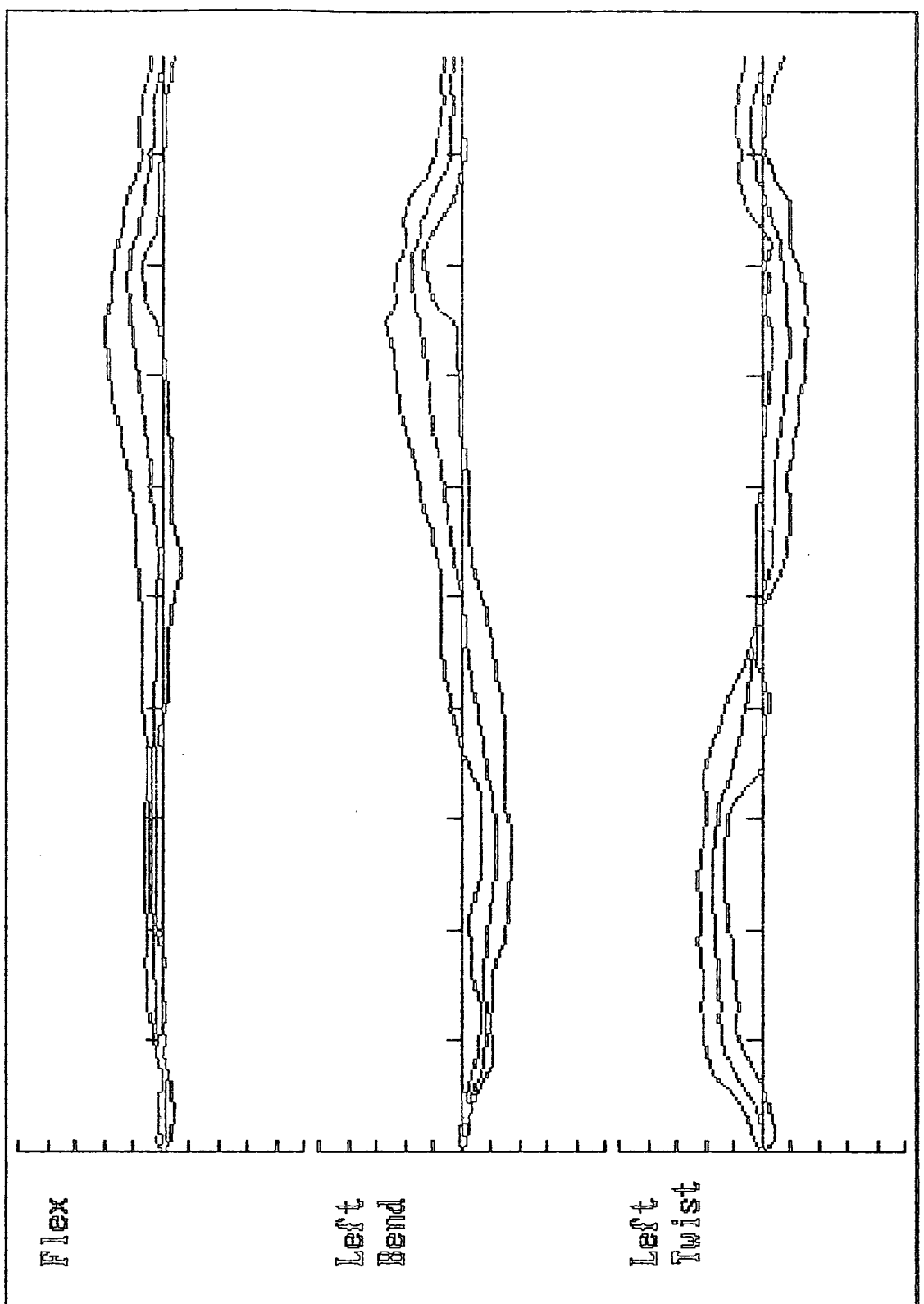

Figure 2.20 — Mean and ± 2 Standard Deviations of a Subject Performing Axial Rotation Five Times in Succession.

Movement ($^{\circ}$)	Subject 1	Subject 2
Flexion-Extension	2.44	7.81
Lateral Bend	1.22	1.92
Axial Rotation	2.77	2.09

Table 2.6 — Standard Deviations for Two Subjects Movements on 5 days

The same two subjects then had their movements measured on ten days, at approximately the same time of day. However, in this trial the spinous process identified as L-1 was not marked after being found and so had to be relocated on each day. This data would allow an assessment of the ability of the two observers' ability to correctly locate the same spinous process of L-1 on each occasion. The results are best expressed in terms of absolute errors, or maximum differences about the mean, rather than standard deviations, they are shown in Table 2.7.

This table not only shows the results of the subjects performing the movements on ten days but also of the repeatability trial, performing the movement five times consecutively, and the trial conducted over five days with the sensor in the same location. The results for the ten day trial will include the variation resulting from the movements being repeated on five days with the sensor in the same position, this in turn will include a measure of that individual's repeatability of movement.* So for example consider subject MP performing lateral bend. Performing this movement on five consecutive days, with the sensor located in the same position, resulted in a maximum variation about the mean of $\pm 3^{\circ}$, this will include the figure of $\pm 1^{\circ}$ produced by repeating the movement five times

*In combination, these three independent factors may not be additive but considered in this way an indication of their individual contributions can be gained.

consecutively. If this $\pm 3^\circ$ is then taken away from the figure of $\pm 5^\circ$ obtained from the ten day trial the remainder, $\pm 2^\circ$, gives an indication of how repeatably the observer was placing the sensor during that ten day period. Referring to Table 2.4 it can be seen that this figure of $\pm 2^\circ$ indicates that during the ten day trial the observer consistently placed the sensor to within $\pm 1\text{cm}$.

Subject	Movement	Ten Day Trial	Repeatability	Five Day Trial
RH	Flexion-Extension	$\pm 15^\circ$	$\pm 5^\circ$	$\pm 3.5^\circ$
	Lateral Bend	$\pm 10.5^\circ$	$\pm 3^\circ$	$\pm 1.53^\circ$
	Axial Rotation	$\pm 3.5^\circ$	$\pm 2^\circ$	$\pm 3.5^\circ$
MP	Flexion-extension	$\pm 10^\circ$	$\pm 2^\circ$	$\pm 12^\circ$
	Lateral Bend	$\pm 5^\circ$	$\pm 1^\circ$	$\pm 3^\circ$
	Axial Rotation	$\pm 9^\circ$	$\pm 7.5^\circ$	$\pm 3^\circ$

Table 2.7 — Results of the Ten Day Trial

It can be noted from Table 2.7 that in some instances the variation resulting from repeating the movement five times consecutively exceeded that found from the five day trial, these difference are small however and could be a reflection of diurnal factors and the 3SPACE system error. The overall impression gained from Table 2.8 is the consistency that the observer shows in sensor placement on the subject MP. This is perhaps not surprising as the observer, RH, was the one who conducted the bulk of all measurements and was therefore more practised.

2.5.8 Rotational Mobility of the Spine Measured with the 3SPACE System

In order to validate the results of the CODA-3 study it was deemed necessary

to repeat the study of twisting in flexed postures using the 3SPACE system. This would also serve as a useful operational test for the system .

2.5.9 Procedure

Twelve physically fit male subjects participated in the study. None had experienced any back pain in the six months prior to the study or had undergone spinal surgery. The mean age of subjects was 33 years (range 22 to 45 years).

The experimental protocol was the same as that used in the CODA-3 study; subjects performing maximal voluntary flexion-extension and axial rotation standing and in the two seated postures, each movement was repeated three times. The only important experimental difference between the two studies being the fact that during the measurement of flexion-extension and standing axial rotation with the 3SPACE Isotrak the subject was able to stand freely without the need for the standing frame used in the CODA-3 study.

2.5.10 Results

As with the CODA-3 study the two seated postures were found to have significantly increased the subject's sagittal flexion from the normal standing position. Using the same definitions as before the first seated posture produced, on average 35% of the subject's maximum flexion and the second some 65%.

Figures 2.21, 2.22 and 2.23 show typical plots of a subject performing axial rotation while standing and in the two seated postures respectively. Figure 2.21 shows greater and more clearly defined opposite lateral bend associated with axial rotation than does the corresponding plot obtained from the CODA-3 study (Figure 2.5). Figures 2.22 and 2.23 again show clearly the considerable flexion

that each of the two seated postures induced.

An increase in maximum voluntary axial rotation was seen to occur in both of the two flexed postures (Figure 2.24). The largest value for axial rotation was observed in the first seated posture and this was found to be a significant increase from the standing value ($p < 0.01$, Paired t-Test). Maximum axial rotation was also significantly higher than the standing value in the second, more flexed, posture but at a reduced confidence level ($p < 0.05$, Paired t-Test).

The results for each individual are shown in Figure 2.25 which indicates the large variation both in the amounts of twisting exhibited and the extent to which the sitting postures induced flexion of the lumbar spine.

2.6 Discussion of Twisting in Flexed Postures

The mean value of standing axial rotation obtained from the 3SPACE study was approximately three times the value one would expect from the lumbar spine. This was due to the strap used to secure the sensor in position over the spinous process of L-1. As was described earlier this served to stop the skin drawing the sensor around the torso and introducing false coupled movements, however, this also caused movement from further up the spine to be included in that recorded. In the CODA-3 study the value of standing axial rotation was much larger due mainly to the strap around the upper thorax which had to be employed because of the bulky nature of the marker rig.

In some individuals an increase of up to 20° was observed when in the first seated posture. The majority of this increase can be attributed to increased mobility of the lumbar spine because the orientation of the thoracic zygapophysial

BACK MOVEMENT

RJH6

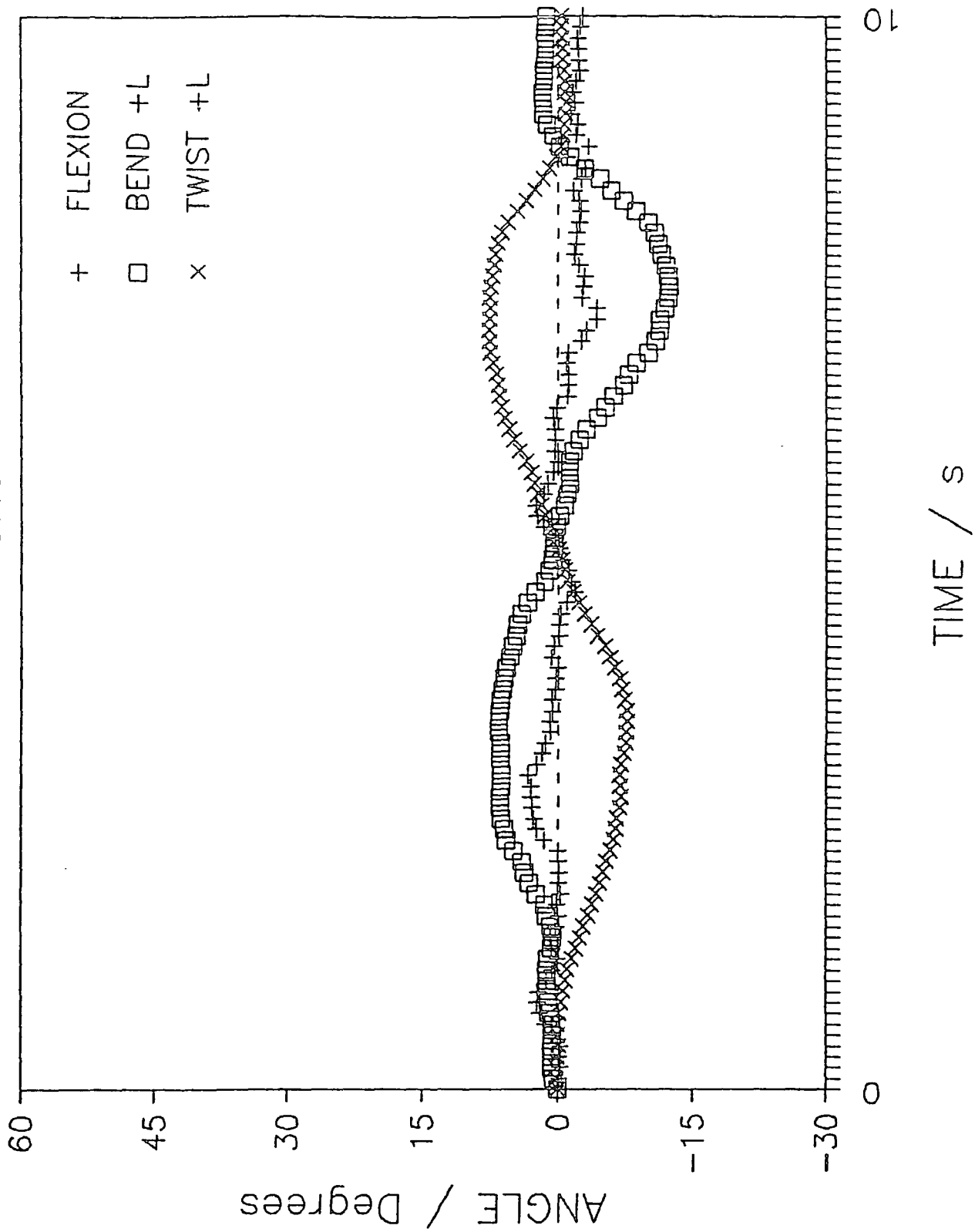

Figure 2.21 — A Plot of a Subject Performing Axial Rotation Standing

BACK MOVEMENT I

RJH12

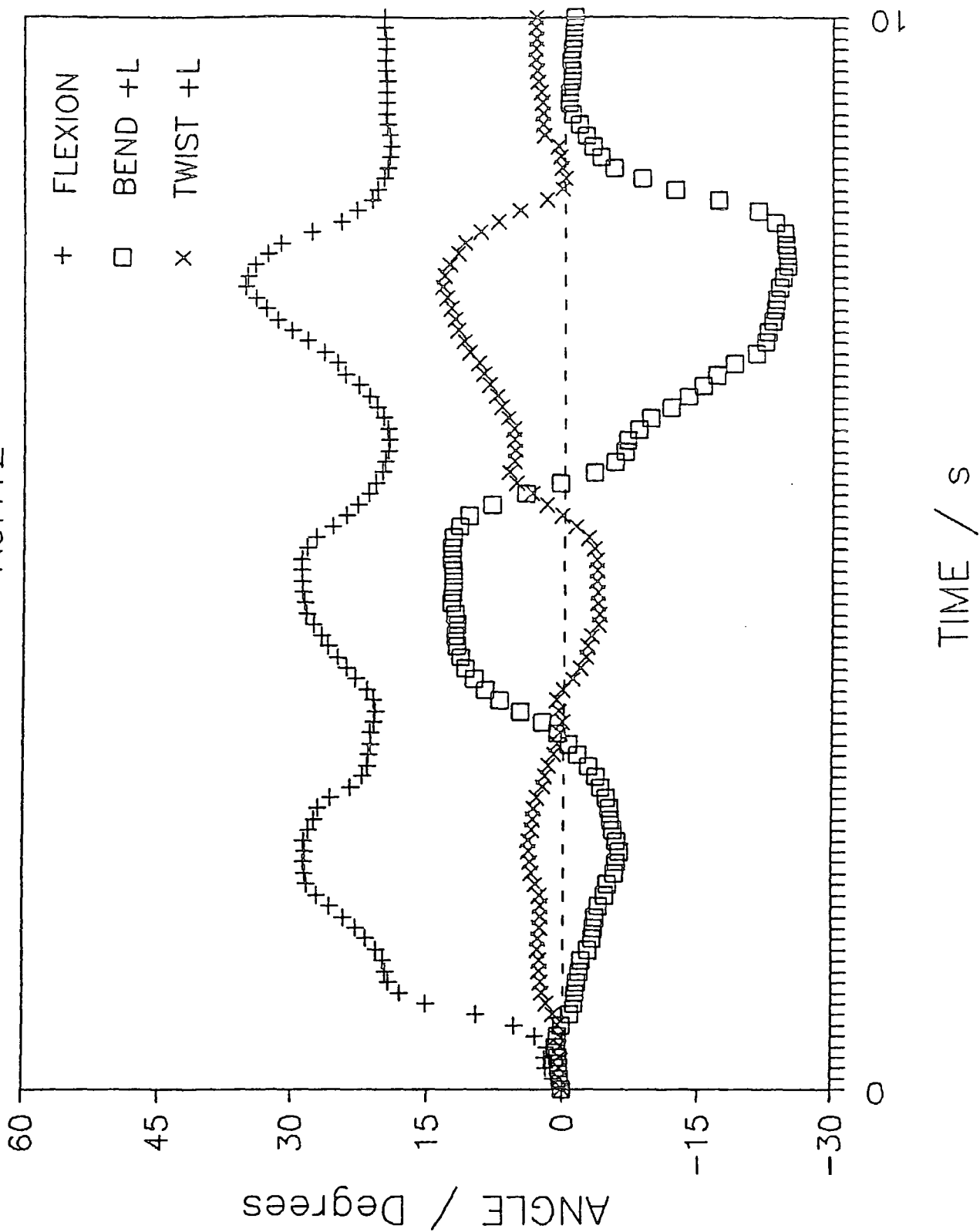

Figure 2.22 — A Plot of a Subject Performing Axial Rotation whilst Sitting

BACK MOVEMENT I

RJH15

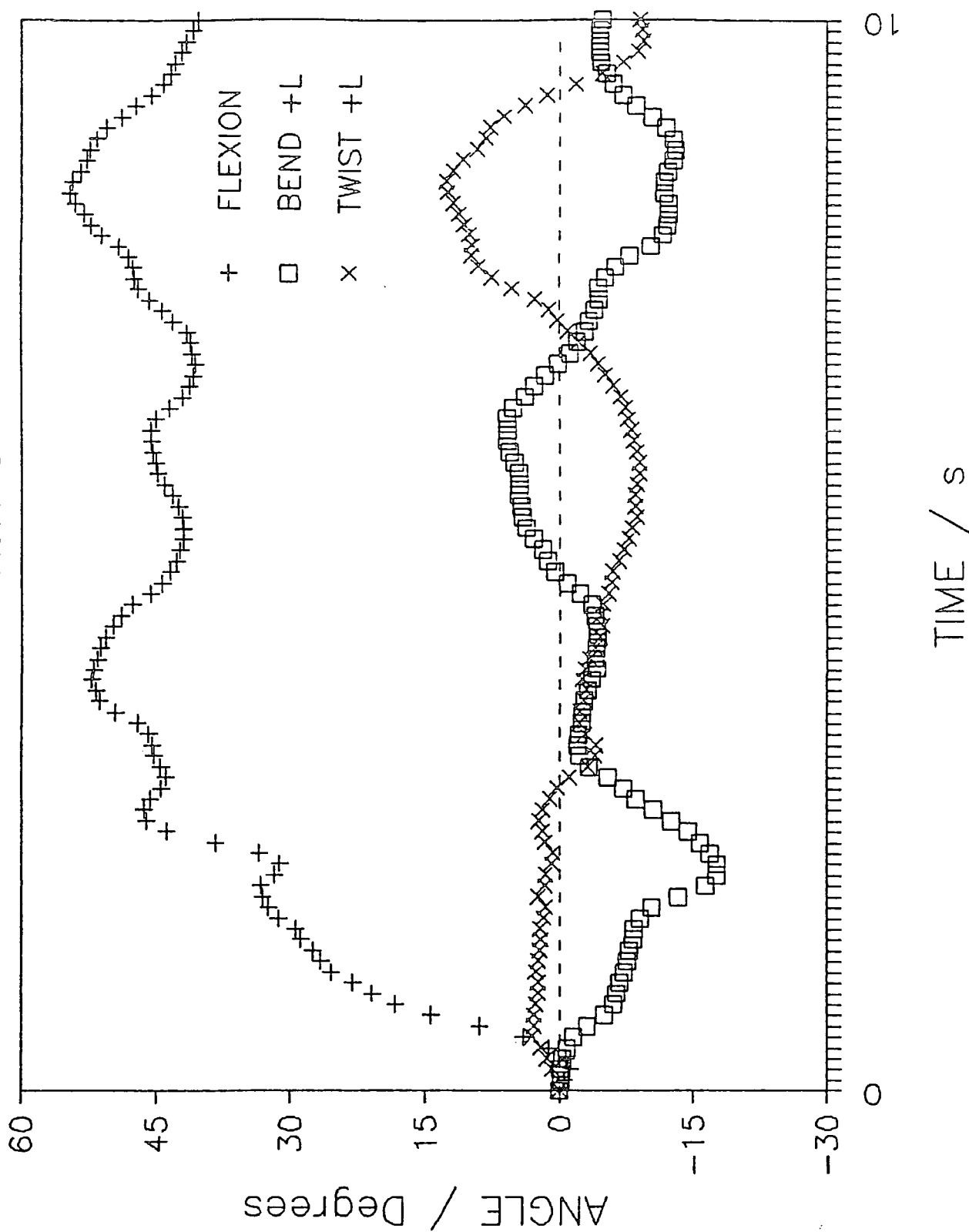

Figure 2.23 — A Plot of a Subject Performing Axial Rotation whilst Sitting Flexed

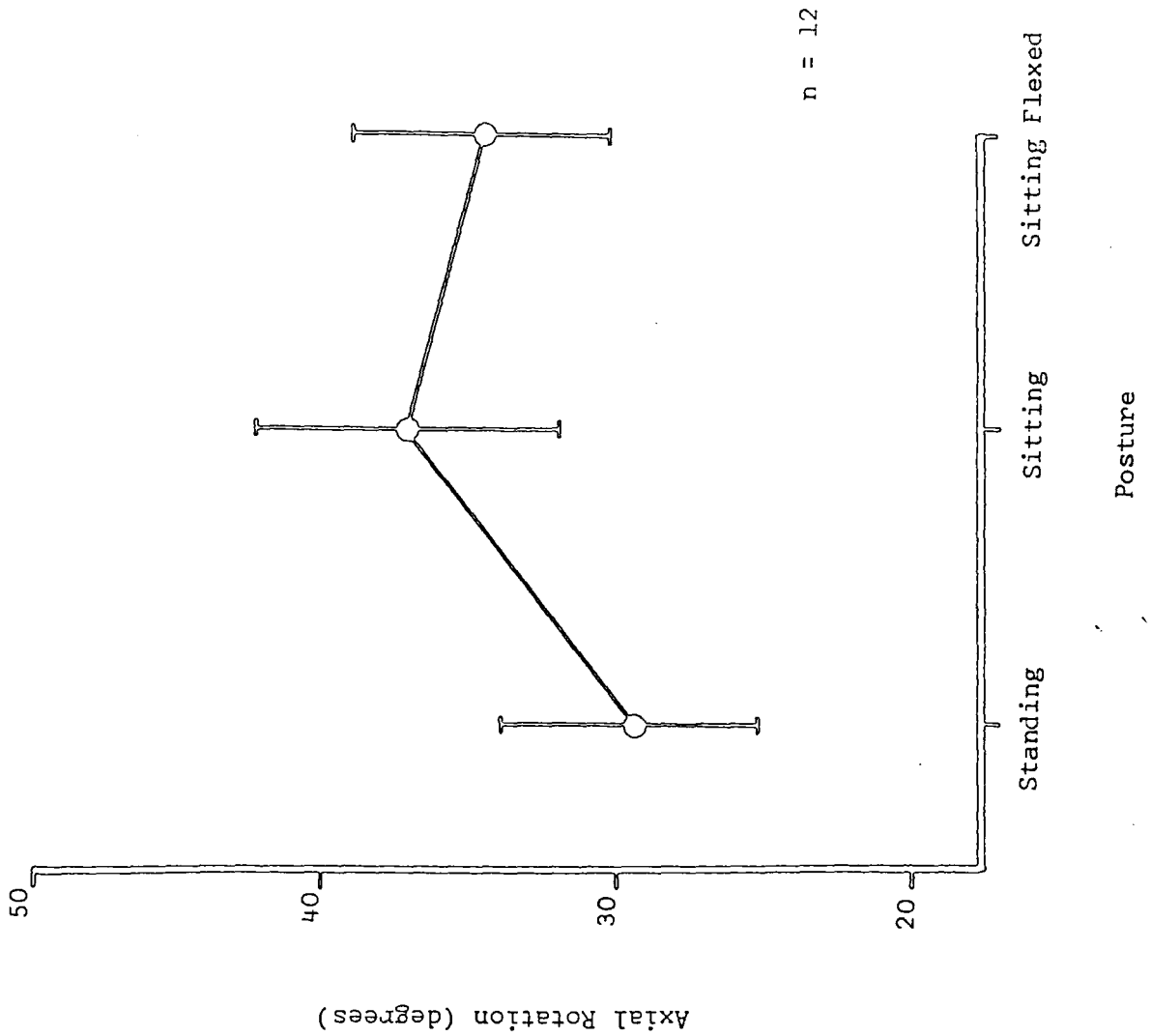

Figure 2.24 — Axial Rotation in the Three Postures

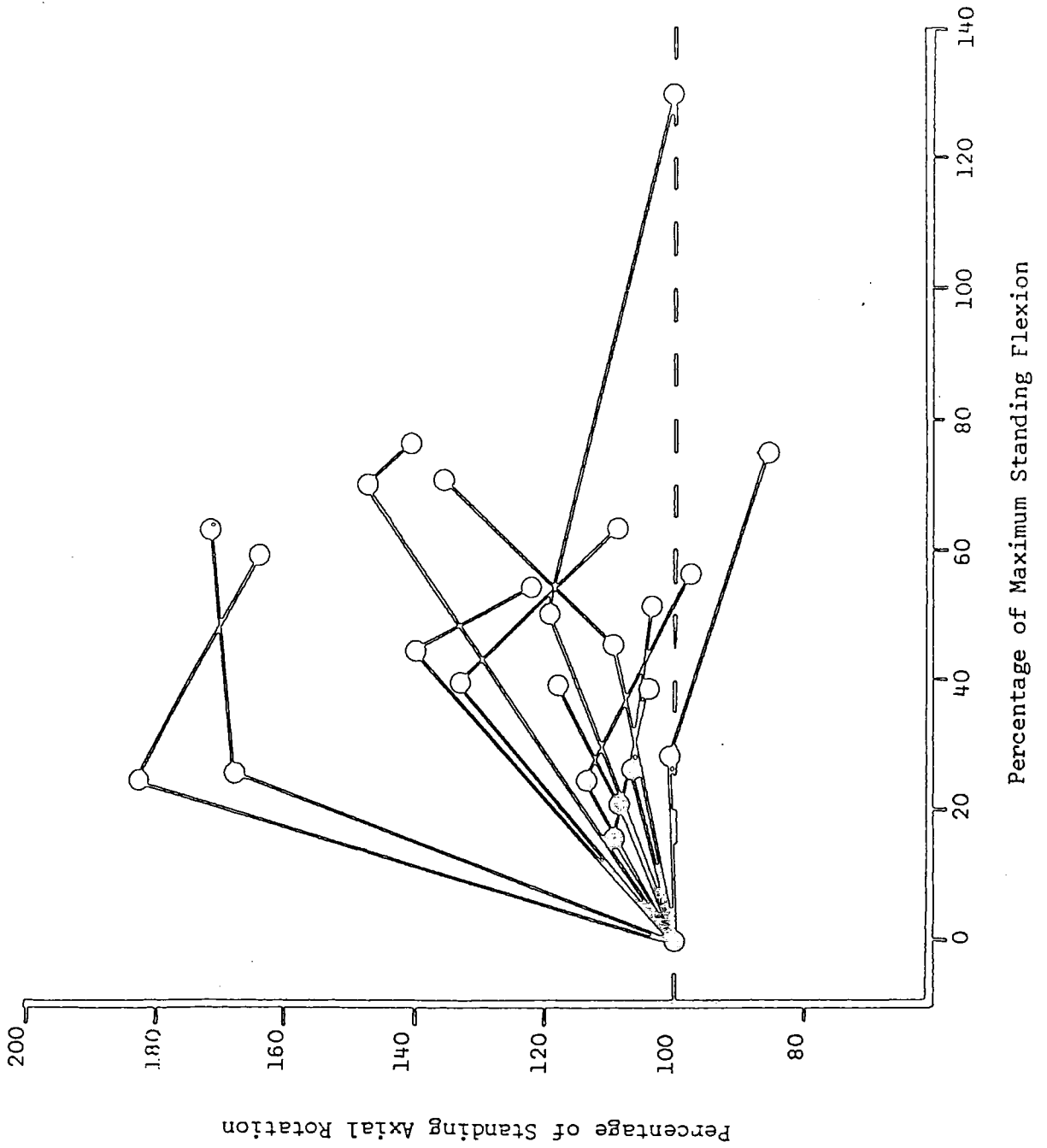

Figure 2.25 — The Relationship between Flexion and Axial Rotation

joints is such that, even in the upright position, almost unhindered rotation is available. Even if they are removed torsional stiffness is almost unchanged (Markolf 1972). Therefore, in some individuals an extra 3-4° of rotation may be available at each lumbar joint when the spine is flexed.

Gregerson and Lucas (1967) measured the movement of Steinman pins inserted into the lumbar spinous processes of volunteers whilst performing axial rotation standing and in a seated posture. They noted a slight decrease in the rotation possible in the seated posture. However, they attempted to maintain a 90° thigh-trunk angle in their subjects. This would have maintained the lumbar lordosis so locking the zygapophysial joints together. This was not the case in this study where flexion was shown to increase in both the seated postures.

The orientation of the facets in the lumbar zygapophysial joints is subject to individual variation and this fact helps explain the considerable variation seen with respect to patterns of flexion and rotation. Subjects with acutely oriented facets in their zygapophysial joints would require considerably more flexion to produce an increase in rotational ability than others, with more oblique facets, who would require only small amounts of flexion to show an increase in rotation. Figure 2.25 shows this individual variation. Unfortunately it was not possible to examine radiographically the morphology of the zygapophysial joints of the subjects in this study.

Figure 2.24 demonstrates that axial rotation actually fell slightly in the second, most flexed, seated posture, as measured by the 3SPACE Isotrak. It would seem, therefore, that there is some optimum degree of sagittal flexion that will permit increased rotation. Beyond this point a tightening of the posterior soft

tissues such as the supra and interspinous ligaments, along with the capsules of the zygapophysial joints themselves, may lead to a reduction in the ability of the joint to twist. However, there is confusion in the literature concerning the mechanical characteristics of these ligaments and the topic will be covered in more depth later in the thesis.

2.7 Conclusions of the Twisting Studies

The CODA-3 study suggested and the 3SPACE study confirmed that some degree of sagittal flexion does permit greater axial rotation to occur in the lumbar spine.

Adams and Hutton (1981) are of the opinion that torque is unimportant in the production of damage to the intervertebral disc because the rotational angles required to initiate damage to the annular fibres cannot be achieved due to the limiting effect of the zygapophysial joint in compression. However, they themselves point out that a loss of 3mm of articular cartilage from the zygapophysial joint could permit upto 6° of extra rotation at that joint. Repeated torsional trauma could be expected to lead to a thinning of the articular cartilage. This, combined with the extra rotation available when the spine is flexed, may be sufficient to cause annular damage. Thus, the conclusion of this section of the thesis is that the lumbar spine has a greater rotational capacity in a flexed posture than when erect. This implies that the intervertebral disc may be vulnerable to torsion when twisting is combined with forward flexion. In order to assess if the results observed for the whole of the lumbar spine were consistent with intervertebral joint mechanics it was decided to carry out tests *in vitro* on isolated lumbar motion segments. These tests are detailed in Chapter 3 as are tests

on the mechanical properties of isolated inter and supraspinous ligaments, these being studied to quantify their role in resisting motion at high degrees of flexion.

2.8 A Preliminary Assessment of the 3SPACE Isotrak

The 3SPACE Isotrak has been used successfully in a research setting, conducting an investigation into twisting in flexed postures. This trial allowed the assessment of the system in terms of its suitability as a possible clinical tool. The system seemed to fit the criteria demanded of a future clinical device, namely that it is relatively inexpensive, reliable, accurate, portable, easy to use with relatively low patient contact time and measures movement non-invasively and in three-dimensions. Given these facts it was decided that the 3SPACE Isotrak showed sufficient potential to be used in a clinical trial (Chapters 4 and 5).

Chapter III

In Vitro Studies

3.1 Introduction

This Chapter describes two sets of *in vitro* tests conducted in order to clarify some of the results obtained in the previous Chapter.

3.2 The Mechanical Function of the Posterior Ligaments

In the previous Chapter some degree of sagittal flexion was shown to lead to an increase in maximum voluntary axial rotation. However, the most flexed posture produced a decrease in rotation in comparison to the less flexed posture. It was suggested that this could be due to a tightening of the posterior spinal ligaments, namely the inter and supraspinous ligaments, at the extremes of flexion resulting in a stiffening of the intervertebral motion segments hence restraining axial rotation. The mechanical properties and functions of these ligaments are, however, unclear.

These ligaments are, in fact, at the centre of one of the most contentious debates within biomechanics at present; the mechanism of the human back during lifting. In particular, the source of the moment required to extend the back as a weight is lifted. (Gracovetsky 1989, McGill and Norman 1989).

McGill and Norman (1986,1989) as a result of their modelling, believe the back muscles to be capable of providing all the extensor moment required when

raising the weight of the trunk and an external load, claiming that posterior ligaments and fascia have no role to play. Other workers, however, take the view that the back muscles alone are unable to generate sufficient force to overcome the significant moments exerted by body weight and an external load. In a recent paper Bogduk *et al* (1989) using the most recent anatomical information, conclude that, in heavy lifting, the back muscles must be assisted by some other mechanism. Those suggested include the intra-abdominal ballon mechanism of Bartelink (1957), the thoraco-lumbar fascia mechanism (Gracovetsky *et al* 1985) and the posterior ligamentous system (Gracovetsy 1986a,1986b). However, the magnitude of the extensor moments produced by these mechanisms has been questioned by Macintosh *et al* (1987).

This section of the thesis seeks to clarify the mechanical role of the inter and supraspinous ligaments of the lumbar spine primarily to quantify their role in restraining rotation at high degrees of sagittal flexion. It is also hoped that this information will be of use to modellers, interested in the role of the posterior ligaments in the production of an extensor moment, and also to clinicians, since these ligaments are innervated and damage to them could be expected to lead directly to pain.

Heylings (1978), following earlier work by Rissanen (1960) studied the structure and attachments of the supraspinous and interspinous ligaments in twenty eight human lumbar spines by dissection and histological examination. He found that the interspinous ligament crossed the interspinous space in a posterocranial direction. Heylings also found that ventrally the interspinous ligament joined with fibres of the ligamentum flavum and that dorsally fibres passed into the supraspinous ligament or the medial tendons of the erector spinae. Prestar

(1982), on the other hand, found no connections between the interspinous and supraspinous ligaments. The view of Heylings would seem to be that most widely accepted.

Heylings hypothesised that the interspinous and supraspinous ligaments “are clearly designed to limit flexion”. Chazal *et al* (1985) suggested that in maximum physiological flexion the interspinous and supraspinous ligaments had reached their maximum biomechanical possibilities. Silver (1954) noted that the interspinous ligaments seemed to be stretched at the limit of flexion and Panjabi *et al* (1975) concluded that it was the posterior elements that provided the stability in flexion.

Adams *et al* (1980) found the supraspinous/interspinous ligaments to be slack at small angles of flexion and to come into tension only for the final few degrees of flexion but that they were the first to fail immediately after the limit of flexion was reached. They found that, on average the supraspinous and interspinous ligaments accounted for only 19% of the overall bending moment of the whole intervertebral joint. As a result of their X-ray analysis of *in vivo* ligament deformations during flexion Percy and Tibrewal (1984) concluded that the interspinous ligament could be active only in the extremes of flexion.

As was mentioned in Chapter 1 various workers have noted that the centre of rotation of a motion segment varies instantaneously as the joint flexes or extends, this point being known as the instantaneous axis of rotation or IAR. Ogston *et al* (1984) using data obtained from an X-ray study showed that vertebrae rotate about a variable axis of rotation. Seligman *et al* (1984) showed, by computer analysis of specimens in a test bed, that this axis moved on a locus, which changed as a disc degenerated. They indicated that the position of this centre

of rotation would seem to lie slightly posterior to the centre of the intervertebral disc in the upright position moving anteriorly during flexion. A recent, and very detailed study of the subject, by Pearcy and Bogduk (1988) has shown that the location of the IAR in normal subjects lies on the superior vertebral endplate of the lower vertebra of a lumbar motion segment, just posterior to the centre of the disc. Their work, in agreement with the findings of Seligman *et al* (1984), suggests that for flexion from upright the IAR lies anterior to that for extension from upright, in other words that the locus of the IAR would seem to move anteriorly as a joint moves from extension to flexion. When Adams *et al* (1980) tested their whole motion segments they imposed a fixed axis of rotation anterior to the centre of the disc. Other *in vitro* tests of the isolated ligaments also loaded the ligaments in a manner different to the loading that occurs in life, without a variable axis of rotation.

It can be deduced that the instantaneous axis of rotation moves through a locus of upto 20mm during flexion from extension, moving forwards through the disc. Assuming that, in the normal motion segment, the locus of the IAR moves from the posterior of the intervertebral disc to the centre as the movement passes from extension to flexion it can be calculated from various anthropometric studies of lumbar vertebrae (Nissan and Gilad 1984, Vanharanta *et al* 1985) that the distance from the centre of the ligament to the IAR increases from 30mm at extension to between 45 and 50mm at full flexion.

Thus, in order to clarify the mechanical role of the inter and supraspinous ligaments an apparatus was designed to deform them in a manner representing their true deformations in life.

3.2.1 Procedure

The normal range of lumbar sagittal flexion and extension varies from 13° for L1-2 to 16° for L4-5 (Pearcy 1985). It was decided to test all the specimens in this study over a range of 10°, this value was deemed to be sufficient since it was not possible to accurately assess the zero, or standing, position and since repeated tests were being carried out it would have been unwise to risk straining the ligaments beyond the normal physiological range of motion. As mentioned previously it can be deduced that the distance between the centre of the ligament and the IAR moves between 30mm and 50mm, moving forwards through the disc, from extension to flexion. X

To achieve this the ligaments were mounted between two arms which were fixed to an axle such that the arms rotated about a set axis. The linear translation of a Hounsfield testing machine, used for this study, was converted to rotation via a rack and pinion arrangement (Johnson 1987). Specimens were tested with the axis of rotation fixed in different positions to build up a picture of their function with a variable axis of rotation.

Experiments by Hasberry and Pearcy (1986), following earlier work by Viidik (1973), showed the importance of testing specimens in as close to the conditions that exist inside the body as is possible. Thus the whole apparatus was enclosed in a humidity chamber which kept ideal conditions of 100% relative humidity and 37°C.

The specimens used in this study were removed from cadavers and consisted of two or more adjacent lumbar spinous processes and their associated inter and supraspinous ligaments. Specimens were stored frozen at -20°C until required

for testing. Prior to testing specimens were divided into units of two adjacent spinous processes and the inter and supraspinous ligaments between them, this was achieved by cutting through the centre of the spinous process with a hacksaw, specimens were now ready for mounting in the two ligament housing blocks. During the whole of this procedure Ringers saline solution was used to keep the material moist. The specimen was attached to the housing blocks by means of four metal pins inserted through holes drilled in the bone. A specimen is shown in place inside the humidity chamber prior to testing in Figure 3.1.

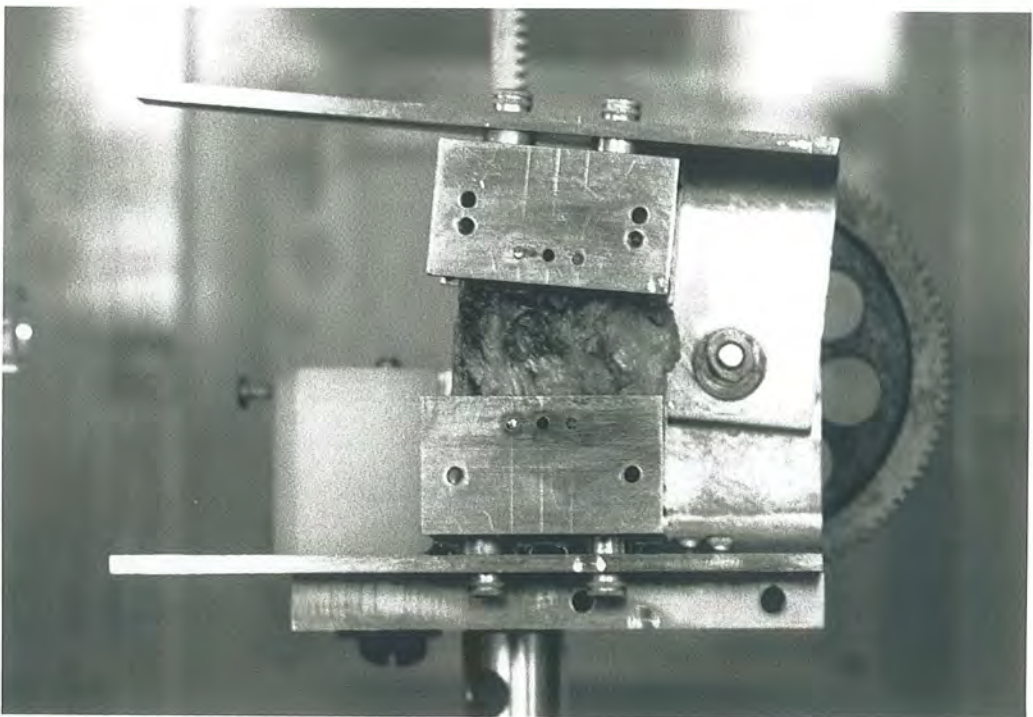

Figure 3.1 — A Ligament in Position

Tests were carried out initially with the interspinous/supraspinous ligament

complex left intact. Tests were carried out with the centre of the ligament 30,35,40,45 and 50mm from the centre of rotation. Half the specimens were tested with the position of the axis in this order and half in reverse. The test cycle consisted of five individual cycles, the fifth being recorded for analysis. This was because, with successively applied strain cycles, the ligament changes its response slightly, a characteristic of visco-elastic materials. Thus by pre-conditioning the specimens a consistent response was achieved by the fifth cycle. Throughout testing the specimen was observed carefully for any signs of failure of the bone around the pins, slipping at the pins or failure of the actual ligament. Following these tests the mechanical action of the supraspinous ligament was removed by sectioning it at the top and bottom of the space between the two adjacent spinous processes. The procedure was then repeated to obtain the characteristics of the isolated interspinous ligament. At the end of each test cycle each interspinous ligament was rotated by 30° in an attempt to cause it to fail.

Since ligaments display properties characteristic of a visco-elastic material it could be expected that different strain rates would produce different mechanical responses. Five specimens were, therefore, tested at two strain rates; a low strain rate, 0.5° per second, the speed used for the other specimens, and a high strain rate, 12.5° per second. This higher strain rate, equivalent to flexing fully from standing in one second, was the fastest rate that the Hounsfield machine used in this study could achieve. Tests were carried out at 30,40 and 50mm from the IAR to the centre of the ligament at low then high strain rates for all five specimens.

3.2.2 Test Material

Thirteen specimens, removed from eleven cadavers (seven male and four fe-

male), were tested (Tables 3.1 and 3.2). Ages ranged from 50 to 87 at time of death, the mean age was 65.7 years. All ligaments appeared healthy upon dissection with no apparent ruptures.

3.2.3 Results

When the intact ligament complex was tested load-extension curves typical of a biological material were produced (Figure 3.2). For an increase in extension an initial phase of low stiffness was followed by a gradual increase in stiffness, the ligaments only taking on load towards the end of flexion. When the ligament was rotated back to its original position the load sustained by the specimens dropped more rapidly than it had increased during flexion.

Comparison of different specimens from the same intervertebral level tested with the same axis of rotation showed strong similarities, even if the ligaments took a greater loading the graph kept its characteristic shape. No consistent differences in the responses of ligaments from different levels were observed.

More interesting is the effect of varying the axis of rotation. For the smallest distance to the axis of rotation, 30mm, all the specimens showed a negligible load carrying characteristic even when flexed to 10° . As the length to the axis of rotation was increased in steps to 35, 40, 45 and 50mm the specimens gradually carried more load, Figure 3.3 shows the response of an L3-4 ligament complex when tested at the varying distances from the centre of rotation. The amount of load increasing more rapidly the longer the length to the axis of rotation. The bending moment resisted by the supraspinous and interspinous ligaments, with the specimen 50mm from the IAR, varied between 1.7 and 4.5Nm at the full 10° of flexion, at the slow strain rate of 0.5° per second, these results are shown in

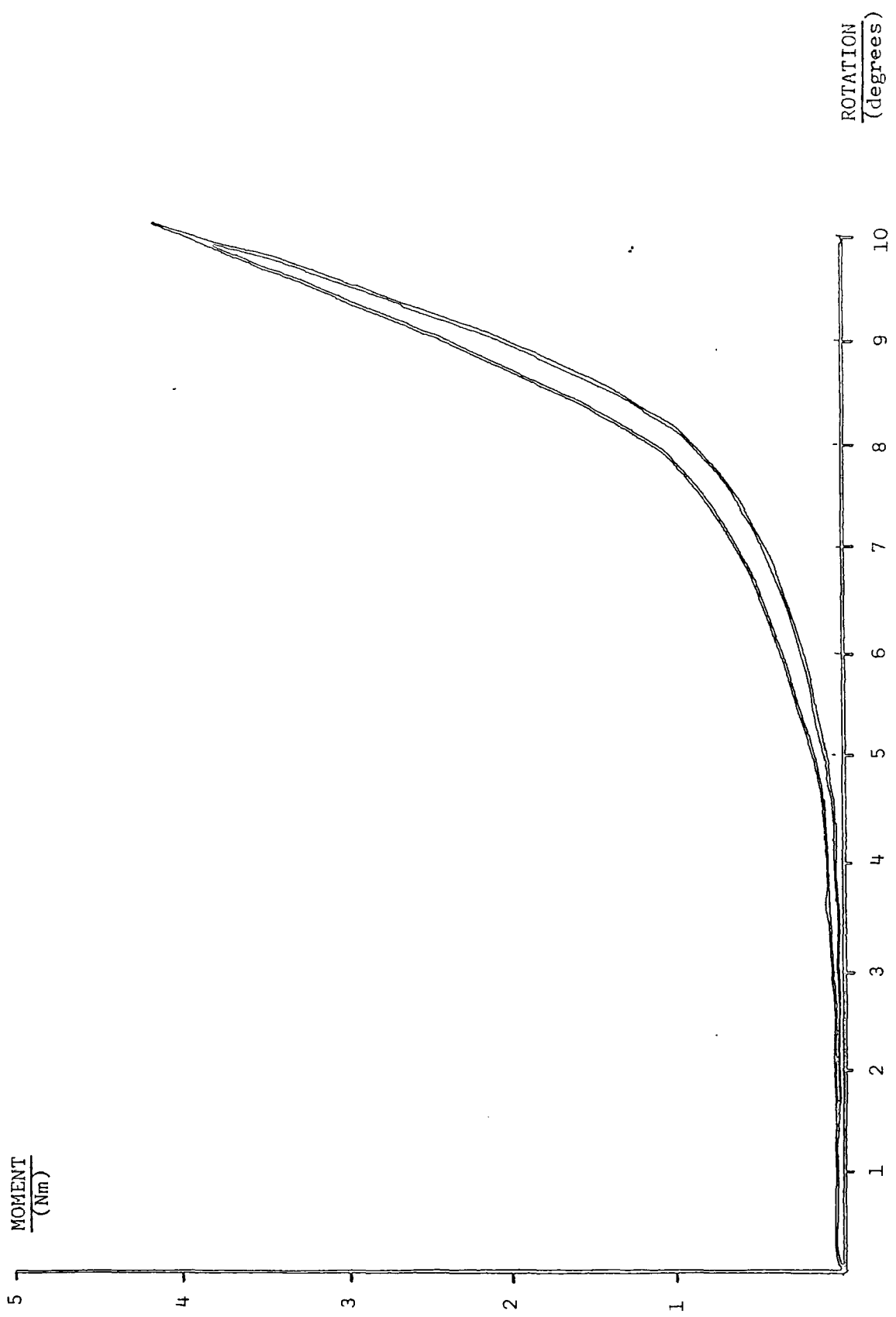

Figure 3.2 — A Typical Response of an L3-4 Interspinous/Supraspinous Ligament Complex

Tables 3.1 and 3.2.

Specimen Number	Age	Sex	Level	Moment (Nm)	Force (N)
1	50	M	L2-3	3.1	62
2	64	F	L3-4	2.2	44
3	58	M	L3-4	2.7	54
4	58	M	L4-5	3.8	76
5	61	M	L3-4	2.4	48
6	61	M	L2-3	2.3	46
7	73	F	L2-3	4.5	90
8	62	M	L4-5	3.6	72

Table 3.1 — Details of the Specimens and Maximum Extension Moment and Force they Produced*

When the supraspinous ligament was sectioned and the interspinous ligament tested in isolation the amount of load carried by the ligament decreased, typically by around 25%. Figure 3.4 shows the typical response of a complete specimen and the response of the interspinous ligament alone at three distances from the centre of rotation. Although the amount of load carried decreased it can be seen that the characteristic shape of the graph is maintained.

When the results for the ligaments tested at both the high and low strain rates are considered it becomes apparent that when loaded at the higher speed the inter/supraspinous ligament complex takes on between 15 and 30% more load

*The force and movement are from the same data set at the maximum IAR at 10° of rotation.

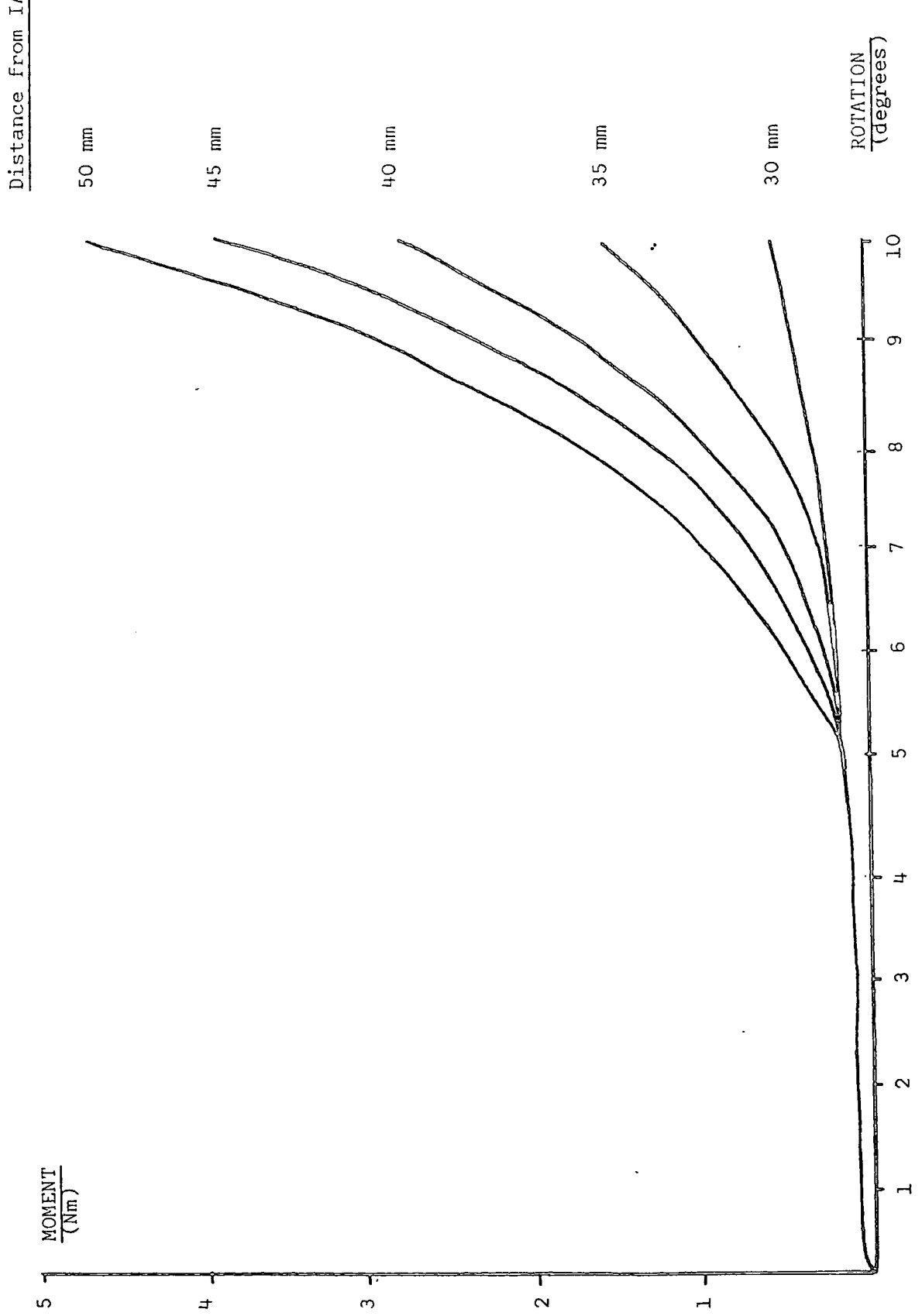

Figure 3.3 — Ligament Response at Different Distances from the Centre of Rotation

Distance from IAR

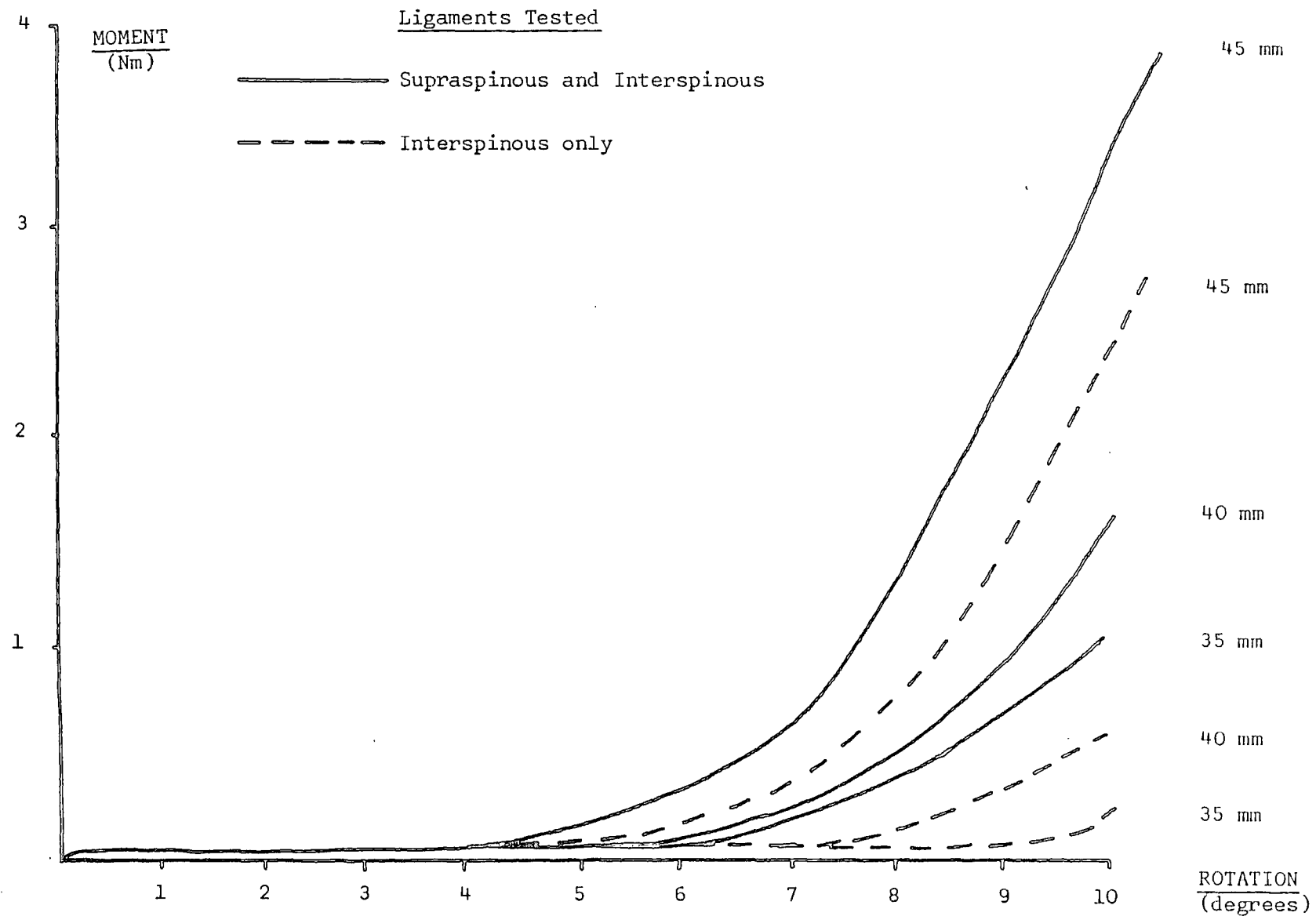

Figure 3.4 — Response of a Combined Ligament Specimen and of the Interspinous Ligament Alone.

(Table 3.2). Figure 3.5 illustrates the typical difference in response shown by low and high strain rate applications in an L3-4 specimen consisting of both supra and interspinous ligaments.

Specimen number	Age	Sex	Level	Low Strain Rate (0.5°/s)		High Strain Rate (12.5°/s)	
				Moment (Nm)	Force (N)	Moment (Nm)	Force (N)
9	65	M	L3-4	4.5	90	5.9	118
10	67	F	L3-4	3.8	76	4.4	88
11	67	M	L3-4	2.0	40	2.5	50
12	67	F	L2-3	5.8	116	6.7	134
13	87	M	L3-4	1.7	34	2.2	44

Table 3.2 — Details of the Specimens tested at both High and Low Strain Rates.

Attempts to produce failure in the interspinous ligaments produced one of two results; either the ligament pulled away from the bone of the spinous process or the extension of 30°, the maximum possible, proved insufficient to induce failure in the ligaments.

3.2.4 Discussion

The purpose of this section of the thesis was to determine the load/extension characteristics of the supraspinous/interspinous ligaments as the locus of the IAR moves from posterior to anterior during flexion. The graph for an IAR 30mm from the ligament could be considered relevant for the first fifth of the extension

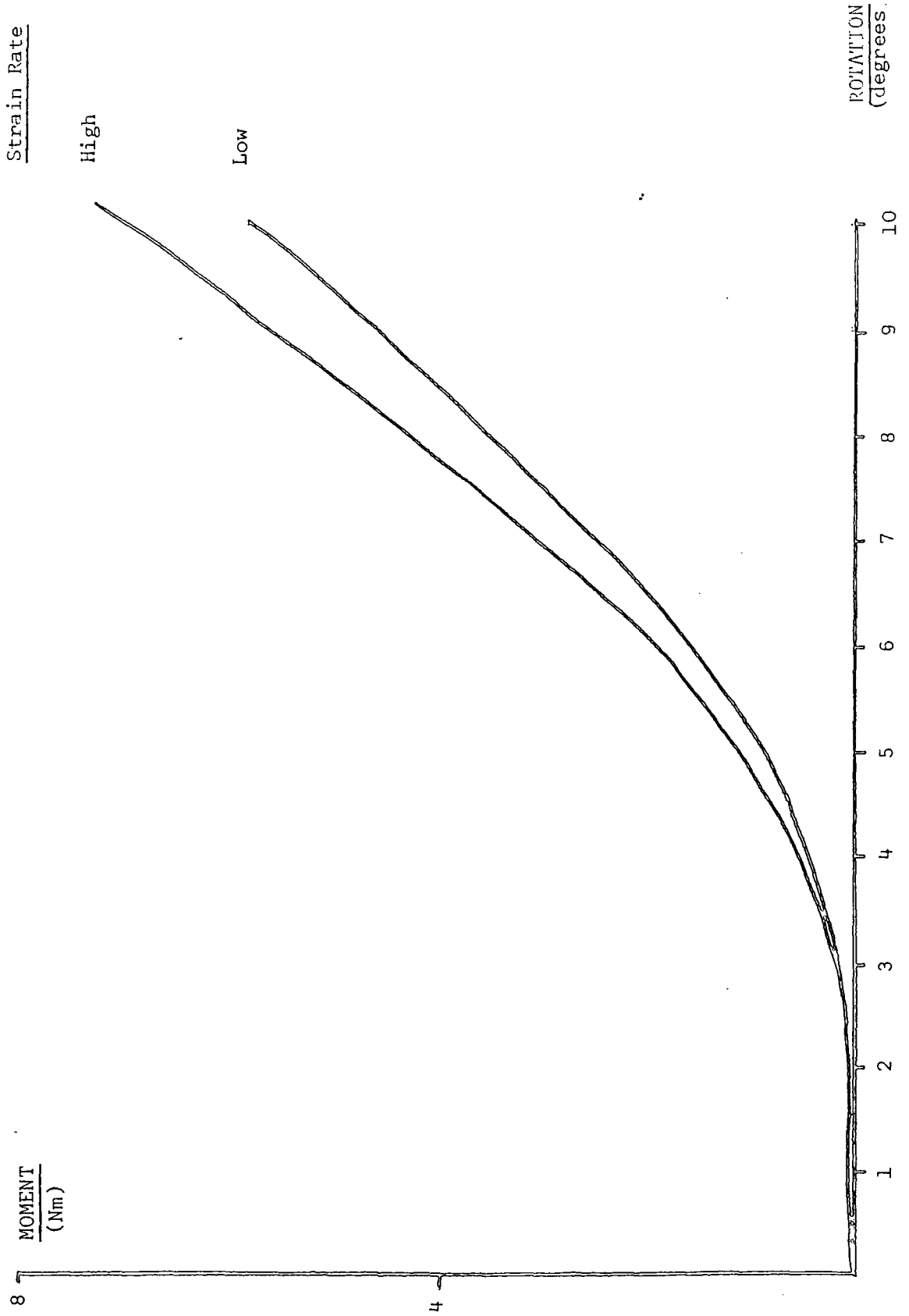

Figure 3.5 — Response of a Specimen Tested at High and Low Strain Rates.

range, since the specimens were tested at five different axes of rotation. The graph for an IAR 35mm from the ligament would therefore only be relevant for the second fifth, and so on, until the graph for the IAR 50mm from the ligament represented the final fifth. The graph for the IAR 50mm from the ligament therefore represents the instance when most bending moment is resisted by the ligament complex, although the initial few degrees of extension will show the ligaments to be carrying more load than is actually the case.

It is apparent from the results that the supraspinous and interspinous ligaments are active only in the later stages of flexion, the amount of load carried increasing rapidly towards full flexion. This observation is in agreement with the results of Adams *et al* (1980) as are the actual values of bending moment resisted by the interspinous/supraspinous ligaments. The values obtained ranged between 1.7Nm and 6.7Nm compared to a mean value of 9.33Nm obtained by Adams *et al*. Their higher values are a reflection of three experimental differences. Firstly, their specimens were drawn from a considerably younger population, secondly their tests were carried out with a centre of rotation anterior to any used in this study and finally they tested their specimens to the limit of flexion, which was more than the 10° used in this study in a number of their tests. From the values of maximum bending moment resisted by the ligaments the amount of load carried can be calculated, these values are shown in Tables 3.1. and 3.2. At the high strain rate a maximum moment of 6.7Nm was resisted, approximately 7% of the value for the whole joint, working from the figures of Adams *et al*, or 5% of the muscle moment available to extend the spine.

Adams *et al* (1980) also remarked that supraspinous/interspinous ligaments were the first to fail after the limit of normal flexion had been exceeded. This

would tend to agree with Rissanen's (1960) observation that "*More than 20% of the adult lumbar spines had visibly ruptured interspinous ligaments and that torn attachments to spinous processes were very common after 30 years of age*". The results also indicate that if forced beyond physiological ranges of flexion the failure of the interspinous ligament at the interface with the spinous process is a likely consequence. Rupture of the ligament may result if vertebrae were forced to move with an IAR over 50mm from the ligament, during trauma for example. It is conceivable, under these conditions of high strain rate and large moment arm, that a small rotation of the vertebrae into flexion would induce a high strain, damaging the ligament. Additionally, Seligman (1984) showed that in patients with degenerative disc disease the locus of the IAR changes, greatly increasing the distance from the IAR to the ligament. For severely damaged discs it is possible that small movements overstrain the interspinous ligaments. This would tend to agree with clinical experience which suggests that the interspinous ligament is damaged only as a result of anterior shear fractures (Personal communication, Cross 1988).*

The attempt during this study to assess the contribution of the supraspinous ligament should be viewed with caution. This ligament is attached across several layers of vertebrae so testing only a section of the entire ligament cannot be expected to represent the mechanical characteristics of the whole ligament. Similarly, it is quite possible that the mechanical response of the interspinous ligament demonstrated here in isolation is unrepresentative of the *in vivo* situation. It is possible that connections with the thoracolumbar fascia may tense the ligament and cause it to take on more load at smaller angles of flexion, providing a mechanism to stabilise the vertebral column when the fascia tightened during

*Sunderland District General Hospital, Kayll Road, Sunderland.

flexion (Bogduk and Twomey 1987). Certainly the direction of the fibres of the interspinous ligament are ideal for retaining the fascia.

3.2.5 Conclusions

This study has demonstrated that the human lumbar interspinous ligament, when tested in isolation and when attached to the supraspinous ligament, only takes on load towards the end of flexion. This does suggest, therefore, that these ligaments could well be responsible for stiffening of intervertebral motion segments towards the end of flexion and hence for the decrease in axial rotation available in this posture that was observed in Chapter 2.

This work has also been able to throw light on the role of these ligaments in the production of the back extension moment. The interspinous and supraspinous ligaments can provide useful assistance in restraining passive flexion but, unless they act in combination with other posterior line tissues such as the fascia, can only provide an additional 5% of the anti- flexion moment that has been calculated to be produced by the back muscles across each intervertebral joint. Thus during active lifting these ligaments, in isolation, have little mechanical function.

3.3 Motion Segment Studies

The increased axial rotation available during flexion was demonstrated *in vivo* for the whole of the lumbar spine in Chapter 2. This section describes mechanical tests carried out on isolated lumbar motion segments *in vitro* in an attempt to confirm this by direct observation.

3.3.1 Apparatus

Apparatus that could subject lumbar intervertebral motion segments to axial rotation in the neutral and two flexed postures was developed following the initial work of Hill-Smith (1987) and Janssen (1989). The whole apparatus is shown in Figure 3.6. The "neutral position" is used to describe the relative positions the two vertebral bodies adopted when unloaded.

The motion segment was held securely by a combination of dental cement and locating screws in two joint holding cups. The lower joint holder was attached, by means of a square hole in its base, to interchangeable base sections which could be used to hold the specimen in the neutral position or at two flexed angles (5° and 10°) which were designed to produce flexion about the physiological axis of rotation. The upper joint holder was secured to a sliding carriage arrangement which consisted of two carriages running at right angles to one another. This allowed the joint to rotate axially about its own centre of rotation. This was then attached to the torque producing section, which allowed the linear movements of the Hounsfield testing machine to be converted into torque. The vertical displacement of the cross-head was applied to two torque conversion bearings via two angled sliders (Figure 3.7). The torque conversion bearings were mounted on a disc supported by a thrust bearing so that the rotational force alone was trans-

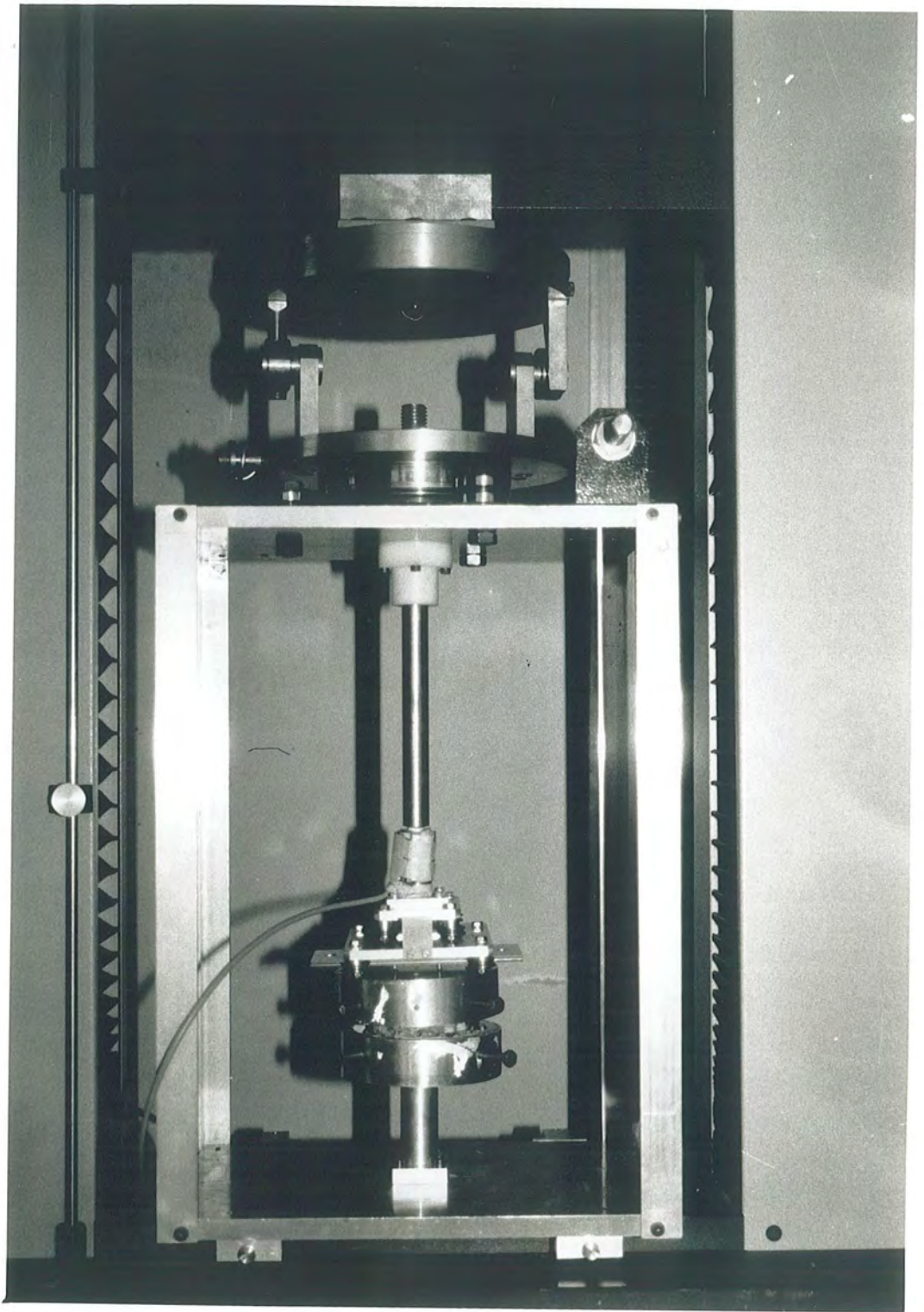

Figure 3.6 — The Torsion Testing Apparatus

mitted to the specimens. This disc was connected to a shaft which transmitted the torque to the sliding carriage and hence to the motion segment.

Two springs attached to the torque disc could be put under tension to provide at least 30Nm of torque and thus hold the torque conversion bearings against the angled sliders. When the cross-head was raised the tension in the springs provided torque in the opposite direction. The torque producing section showing the cross-head of the Hounsfield testing machine, the angled sliders, torque conversion bearings, torque disc and two return springs are shown in detail in Figure 3.7.

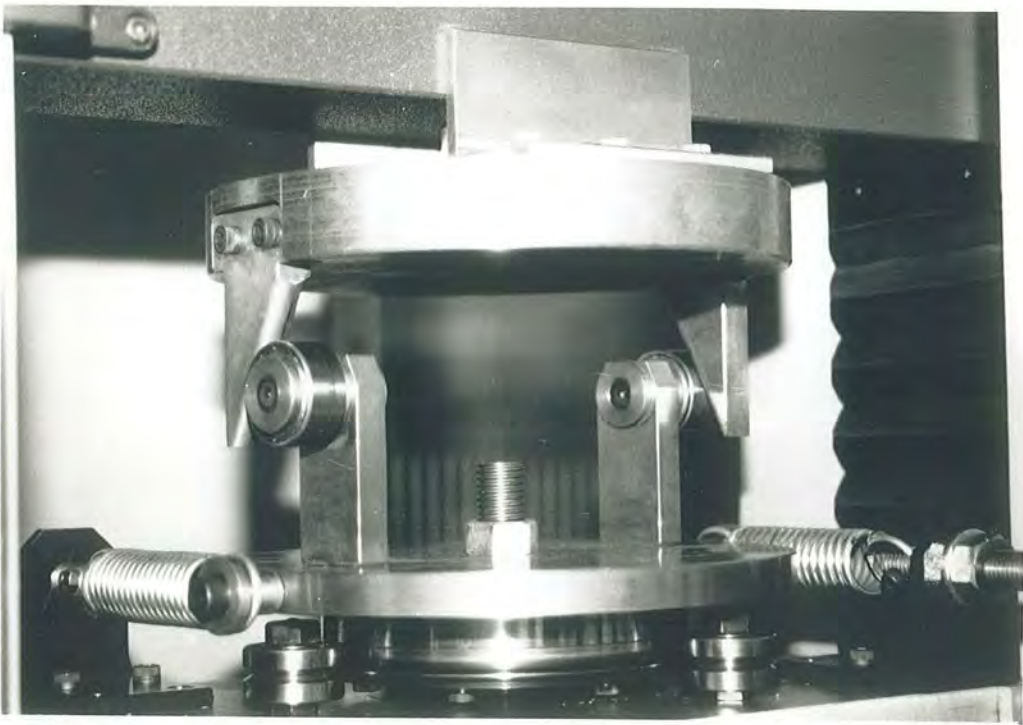

Figure 3.7 — The Torque Producing Section

Strain gauges, designed to interface with the load cell amplifier incorporated in the Hounsfield testing machine, were positioned on the thin walled cylindrical

section that joined the torque shaft to the sliding carriage arrangement. These were calibrated to ± 30 Nm by hanging dead weights on a lever arm system.

A solid block of aluminium inserted in the two joint holders was used to determine the stiffness of the whole apparatus. Torques of ± 30 Nm and ± 20 Nm were applied to this system to determine the deflection and hysteresis of the apparatus. These characteristics allowed the true angles of deflection of the joints to be calculated, by subtraction. The 20 Nm calibration curve is shown in Figure 3.8.

This calibration curve shows a steady state hysteresis cycle in which the left hand portion of the curve has been rotated about the X-axis, this is illustrated in Figure 3.9. For the specimens the graphs show the parts of the curve for increasing torque only, so that any asymmetry in the response of the specimen can be more easily seen.

3.3.2 Procedure

All specimens used were removed *post mortem* and were stored frozen at -20°C until required for testing. After thawing, excess muscle and fatty tissues were removed and the two vertebral bodies sectioned, leaving sufficient bone for secure attachment to the joint holding cups. This attachment was achieved by placing the joint into one of the cups into which had been prepared some fast setting, cold cure, dental plaster. The three securing screws were then screwed in so that they firmly held the bone of the vertebral body. The plaster was then left to harden and a similar procedure performed for the second joint holder. During dissection and testing exposed parts of the specimen were kept moist with Ringer's saline solution.

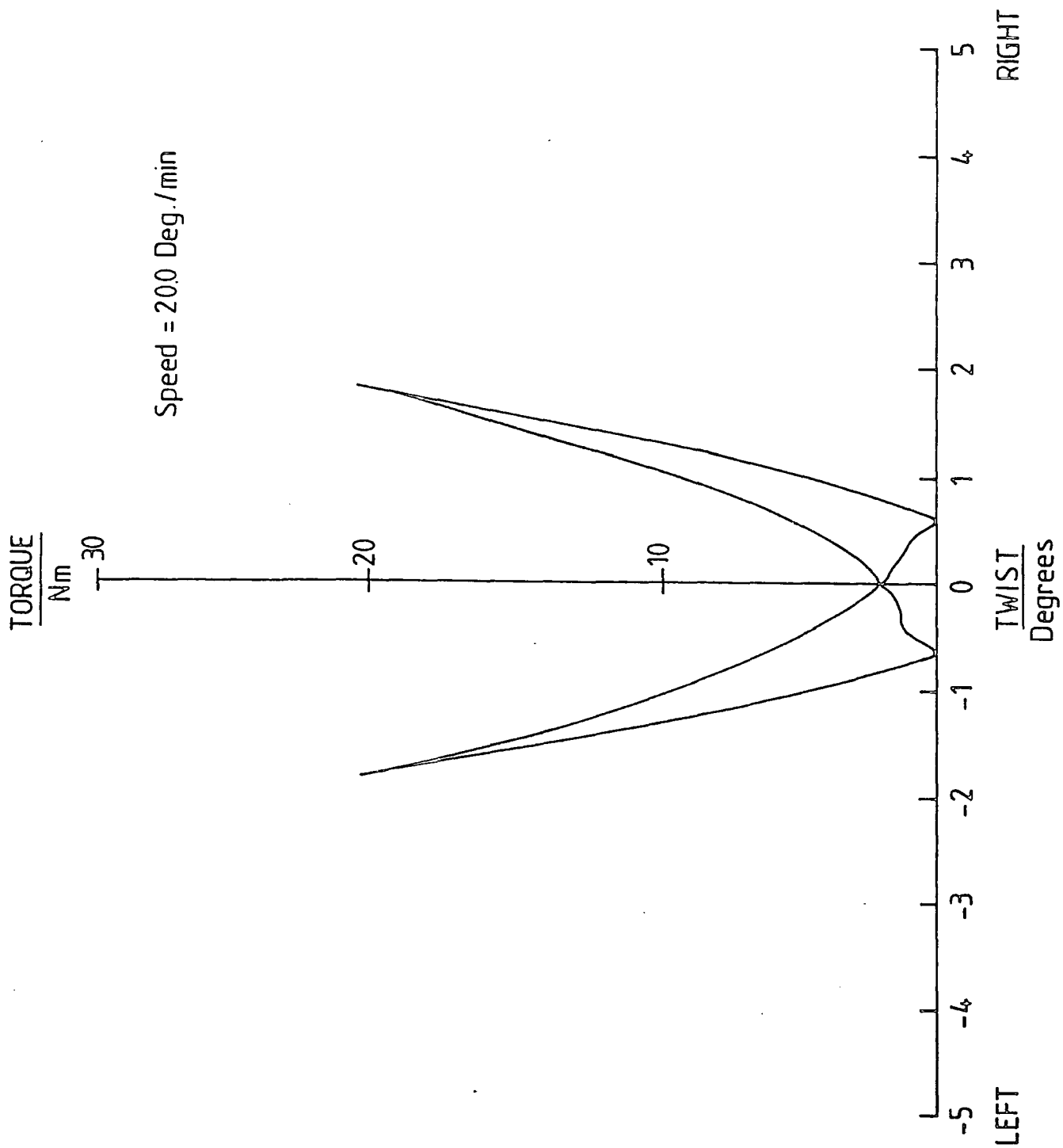

Figure 3.8 — 20 Nm Calibration Curve

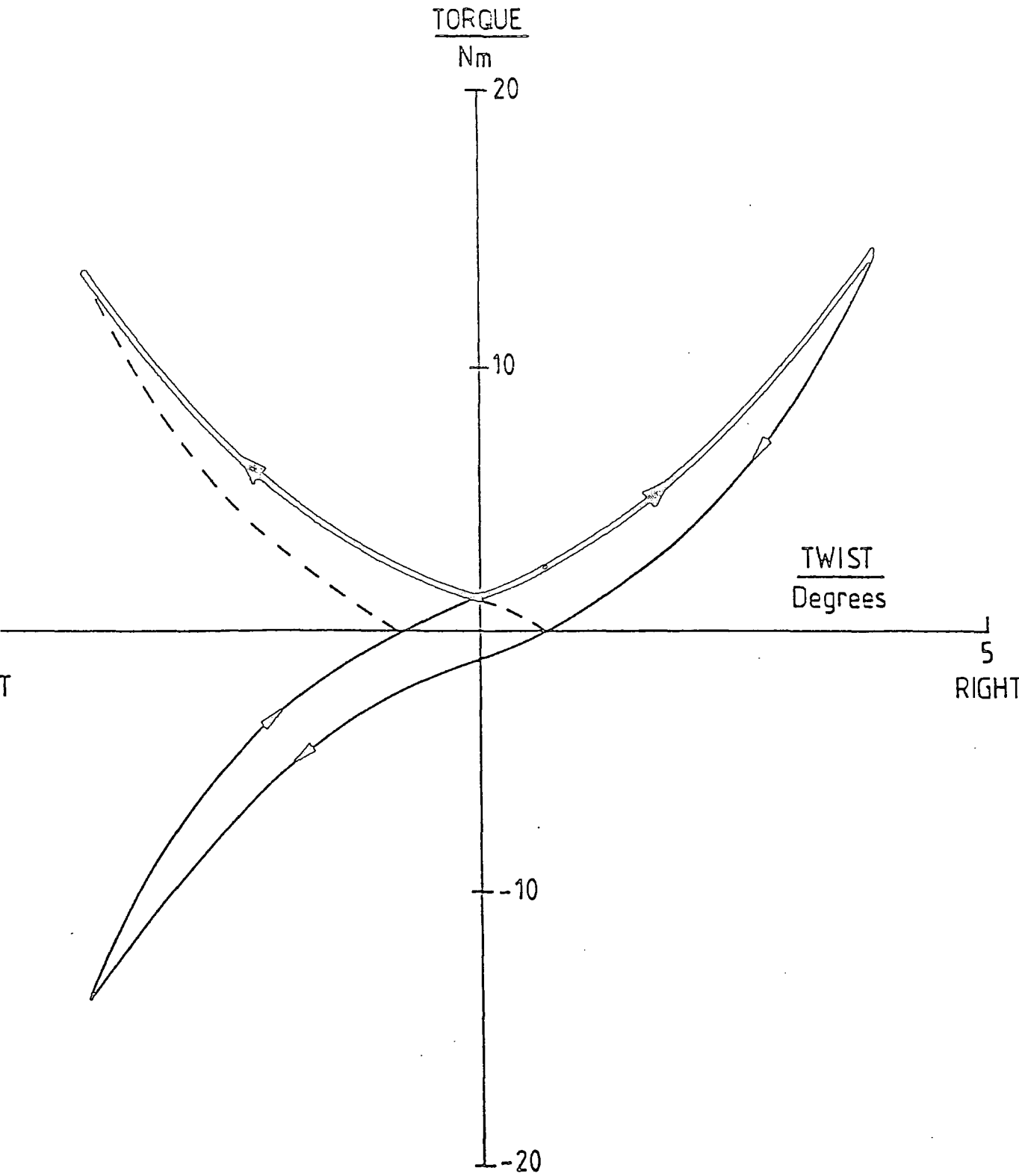

Figure 3.9 — Presentation of Torque Response Characteristics

Before any torsional tests could be carried out a simple compression test was performed on each specimen to assess the degree of deformation needed to achieve a preload of 350N, giving an approximate representation of the load imposed on lumbar vertebrae by body weight. This load was progressively applied to the specimen and the deformation produced was recorded.

The apparatus was then set up ready for testing. The lower joint holder was placed over the unangled base shaft and the torque shaft was then wound down to secure the upper joint holder. The torque shaft was then further wound down, as accurately as was permitted by its rather coarse thread, by the amount required to apply the 350N preload and its locknut tightened. The cross-head was then lowered until the two angled sliders sat against the torque conversion bearings. Finally, the two springs were put into tension. Testing could now begin. A specimen in place for testing is shown in Figure 3.10.

Each specimen was first subjected to a deformation of approximately $\pm 1^\circ$, in order to identify the zero position of the joint, the point at which the specimen was not in any degree of rotation. The joint was then rotated to approximately $\pm 2^\circ$ at a speed of 20° per minute twice to check the consistency of response and the torque resisted to each side recorded. The reverse procedure to that described for assembling the apparatus was then performed and the two joint holders and specimen removed. The flat base shaft was then removed and replaced with the one angled at 5° , the joint was then replaced and the equipment set up again. The same pre-load as before was applied as well as any extra load necessary to ensure that the flexed posture was fully adopted. After the zero position had been identified the joint was rotated, again at 20° per minute, to those torque values that had been recorded previously, the angular deformation produced to

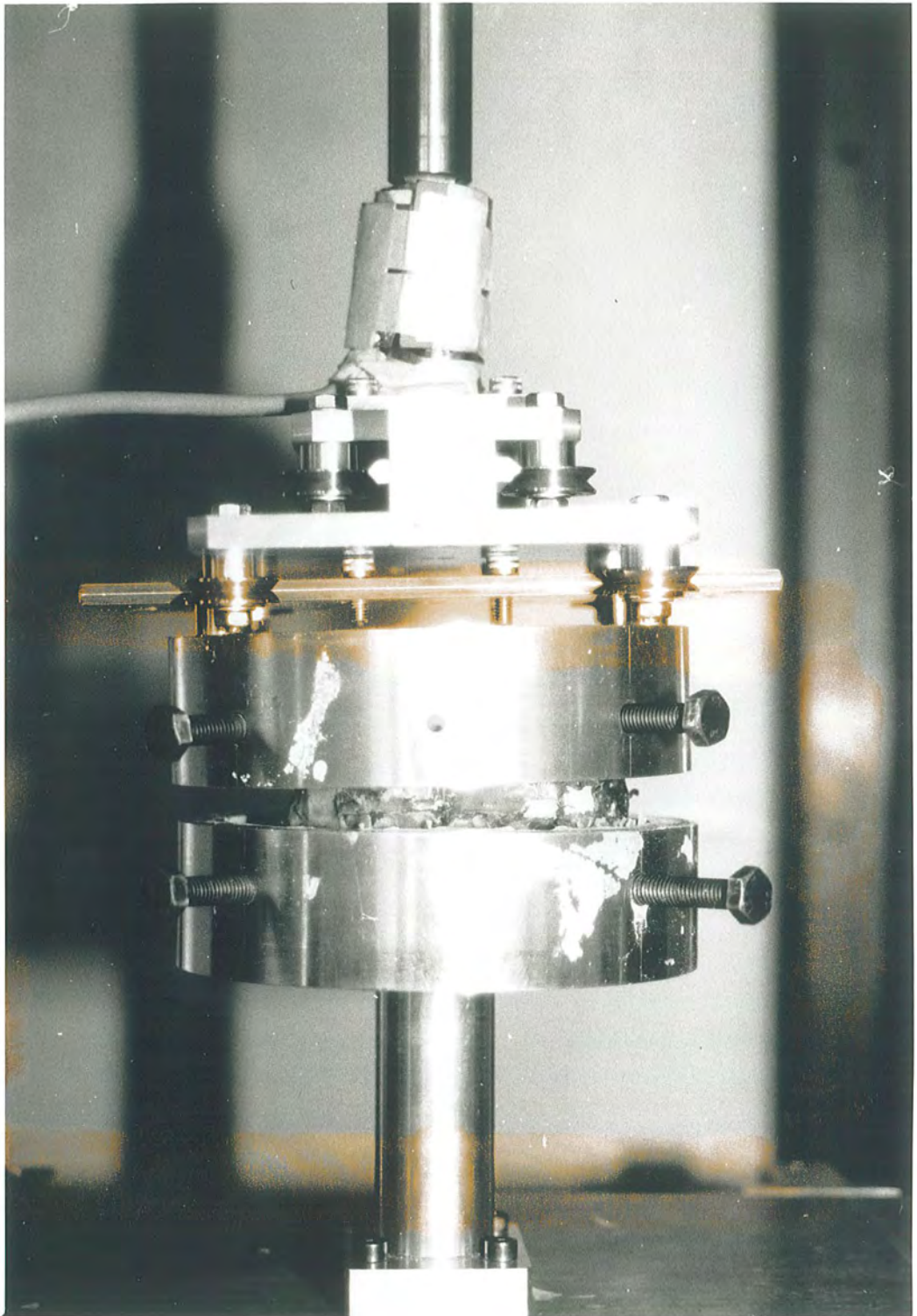

Figure 3.10 — A Motion Segment in Place for Testing

each side was recorded. The same procedure was then performed for the base plate that flexed the joint to 10°. At the end of each session the neutral base shaft was replaced and the specimen retested to determine if the testing had caused any alteration to the joints' original characteristics.

After testing and removal from the joint holders the intervertebral disc was sectioned and examined for any sign of degeneration and lesion. An assessment was then made of the orientation of the two zygapophysial joints, they too were examined for signs of failure. A photograph was then taken of each sectioned specimen.

3.3.3 Results

Lumbar motion segments require considerable time to remove from the body and as a result are in relatively short supply, therefore, only five motion segments were tested, details of which are shown in Table 3.3.

Number	Sex	Age	Level	Cause of Death
1	M	48	L4-5	Alcoholic Hepatitis
2	M	66	L3-4	Broncho-pneumonia
3	M	61	L3-4	Pulmonary Embolism
4	M	75	L4-5	Respiratory Failure
5	M	64	L4-5	Pulmonary Embolism

Table 3.3 — Specimen Details

The fact that all specimens were male was not a deliberate part of the experi-

mental protocol but was purely the way the specimens arrived. No abnormalities were apparent in any of the specimens prior to testing.

Table 3.4 shows the angles to which each joint was initially rotated (both to left and right), and the torque that was resisted at these points. It also shows the extreme angles that were reached to each side when the joint was subsequently rotated to the pre-determined torque when flexed at 5° and 10° . All of the angles represent the actual angle the joint was rotated through after the characteristics of the apparatus, as determined from the calibration tests, had been removed.

Specimen Number	Direction of Twist	Initial Torque Resisted (Nm)	State of Flexion		
			Neutral	5°	10°
1	Left	17	1.95°	2.15°	1.55°
	Right	22.5	1.85°	1.60°	1.10°
2	Left	19	2.20°	-	2.65°
	Right	25	1.65°	-	2.40°
3	Left	14	2.55°	3.90°	3.70°
	Right	14	2.55°	3.95°	3.70°
4	Left	12.5	2.65°	4.00°	4.35°
	Right	12	2.70°	3.75°	4.50°
5	Left	14.5	2.5°	3.75°	-
	Right	12.5	2.70°	3.50°	-

Table 3.4 — Characteristics of the Specimens

The Table reveals that the initial angle to which each specimen was rotated showed a degree of variation, although the cross-head was moved through the

same distance in each case. This was due to the response of the apparatus itself; the higher the torque that was resisted by a joint the more the apparatus deflected and hence the joint was rotated to a lesser degree.

The responses of all the specimens are shown in Figures 3.11 to 3.15. They show angular deformation plotted against torque resisted by the joint in the neutral and two flexed postures. They, again, have been adjusted to take account of the rig's own response.

As was mentioned previously each specimen was sectioned and photographed after testing, these photographs are shown in Figures 3.16 to 3.20. These figures also show a tracing of the articular surfaces of the zygapophysial joints of each specimen, making their morphology clearer.

Specimen 1 showed increased rotation to the right, when flexed at 5° and the torque determined from the test in the neutral position was applied. However, decreased rotation was seen to the left. When flexed at 10° the joint displayed decreased rotation, relative to the neutral position, to both sides.

The results for specimen 2 show that the results for the test carried out with the joint flexed at 5° are missing. During these tests the joint was inadvertently compressed beyond reasonable limits and so produced a much stiffer response than could have been expected, this was only discovered during analysis of the data when the response of the rig was deducted from that of the test and hence the tests could not be repeated. The extra compression resulted from the crude adjustment afforded by the coarse thread of the torque shaft. The results of the 10° test show that in this position the joint had considerably greater rotation to both sides, relative to the neutral position.

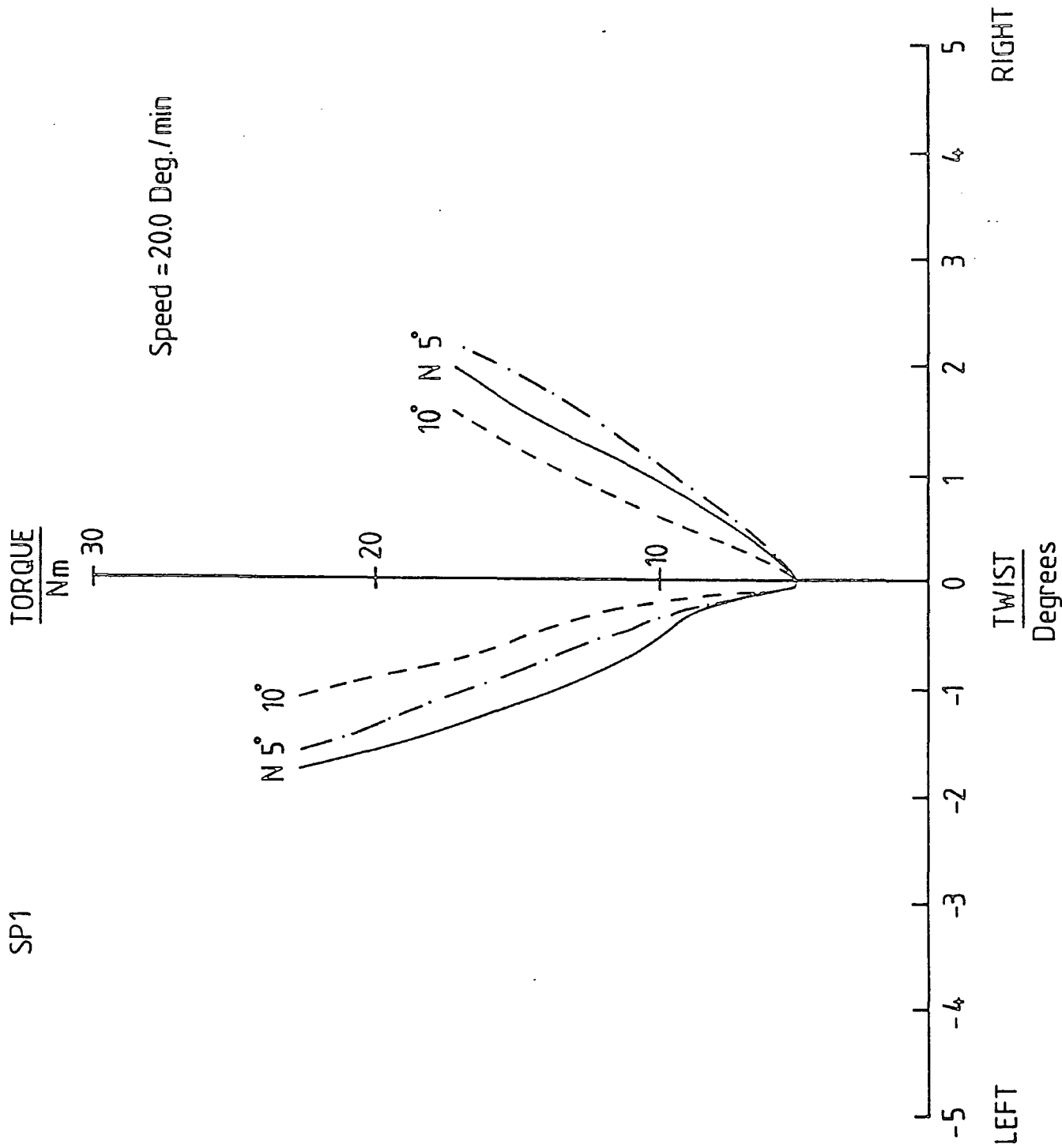

Figure 3.11 — Characteristics of Specimen 1

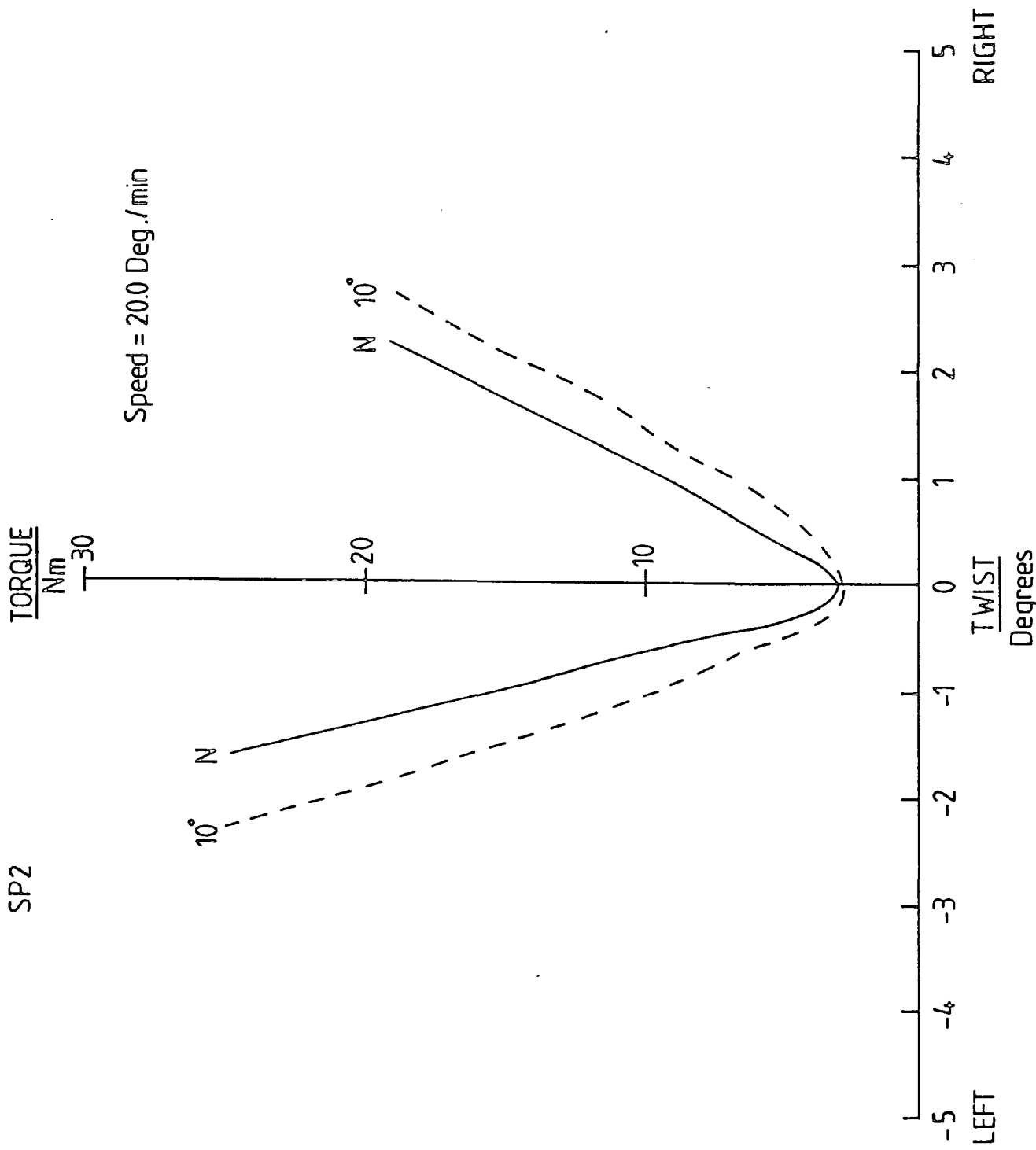

Figure 3.12 — Characteristics of Specimen 2

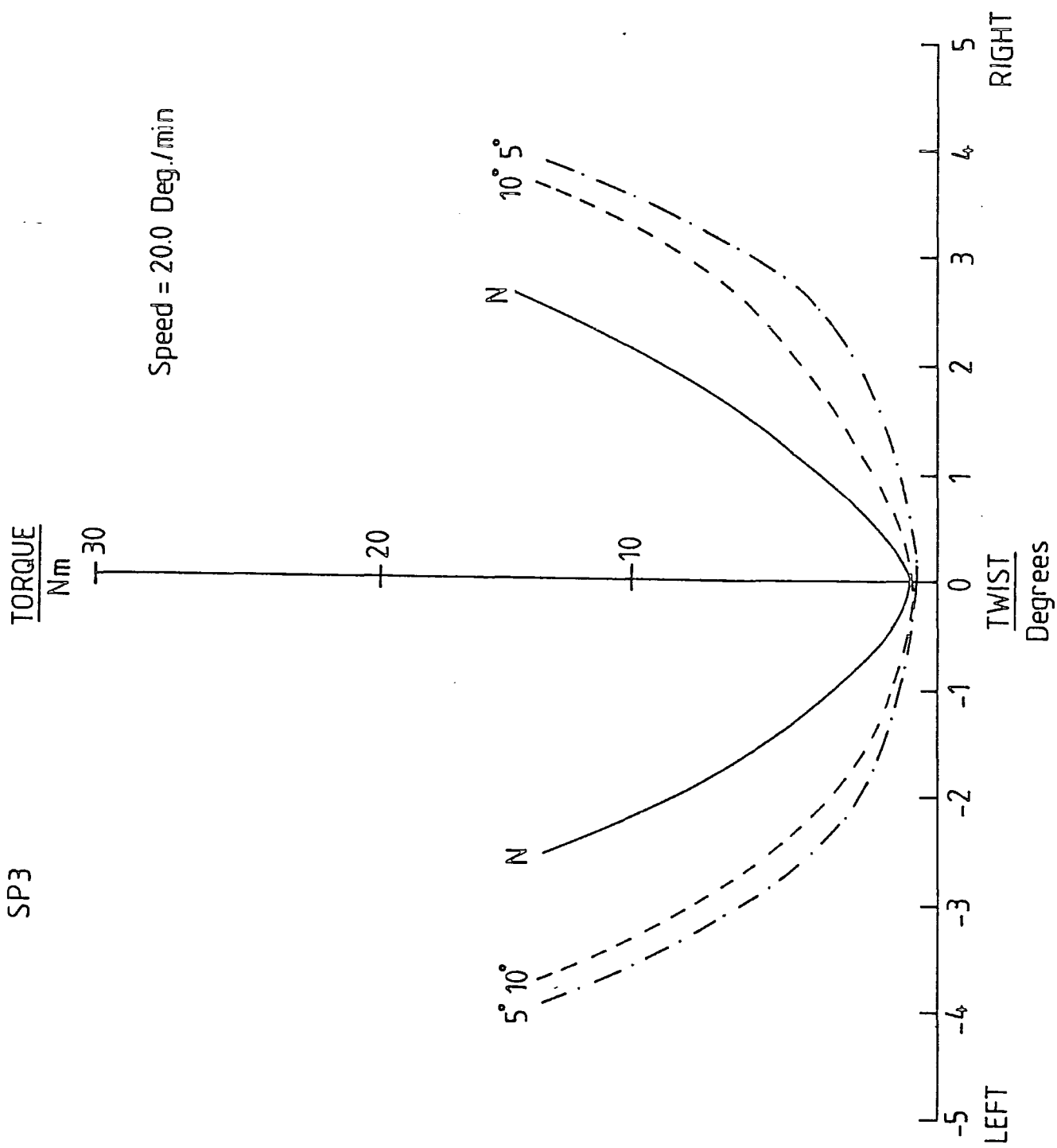

Figure 3.13 — Characteristics of Specimen 3

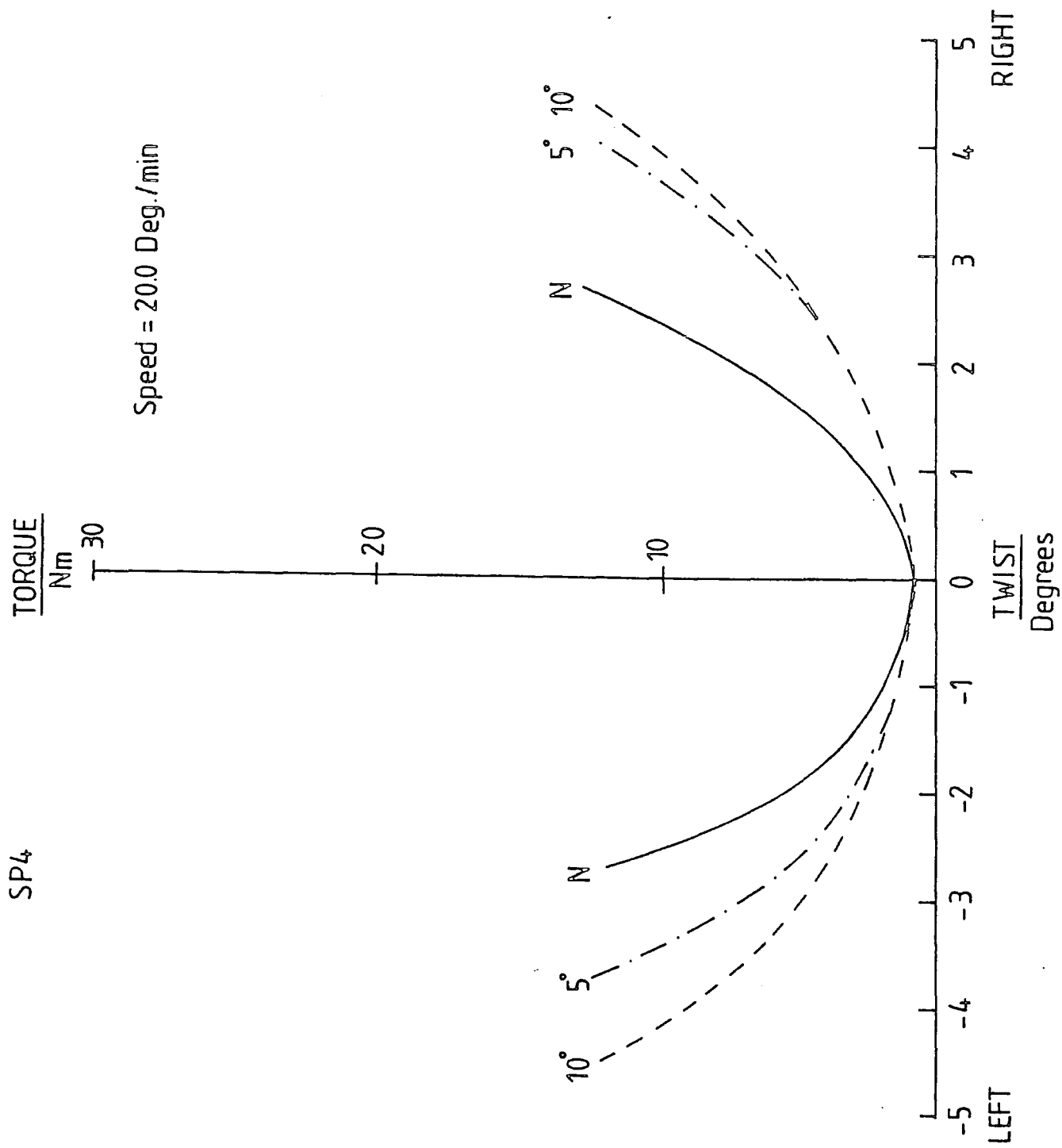

Figure 3.14 — Characteristics of Specimen 4

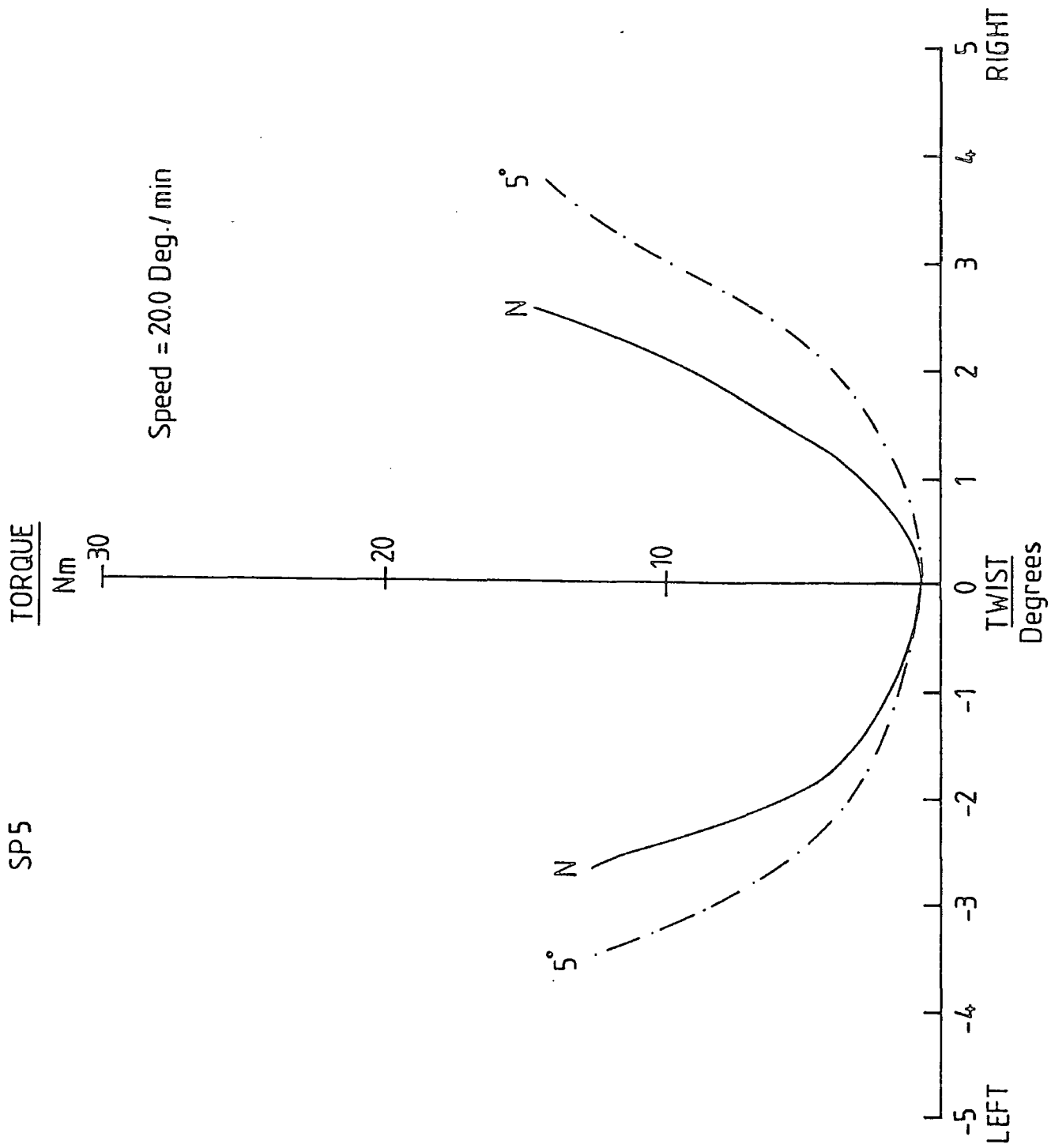

Figure 3.15 — Characteristics of Specimen 5



Figure 3.16 — Specimen 1

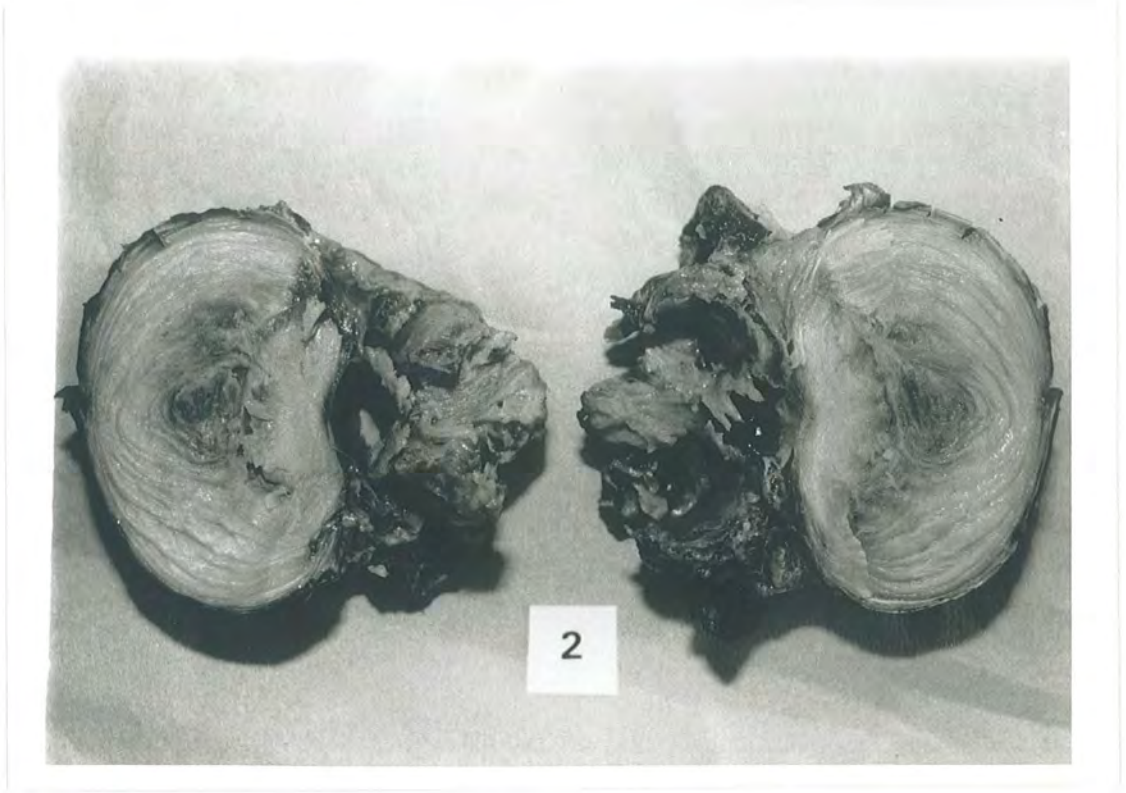

Figure 3.17 — Specimen 2

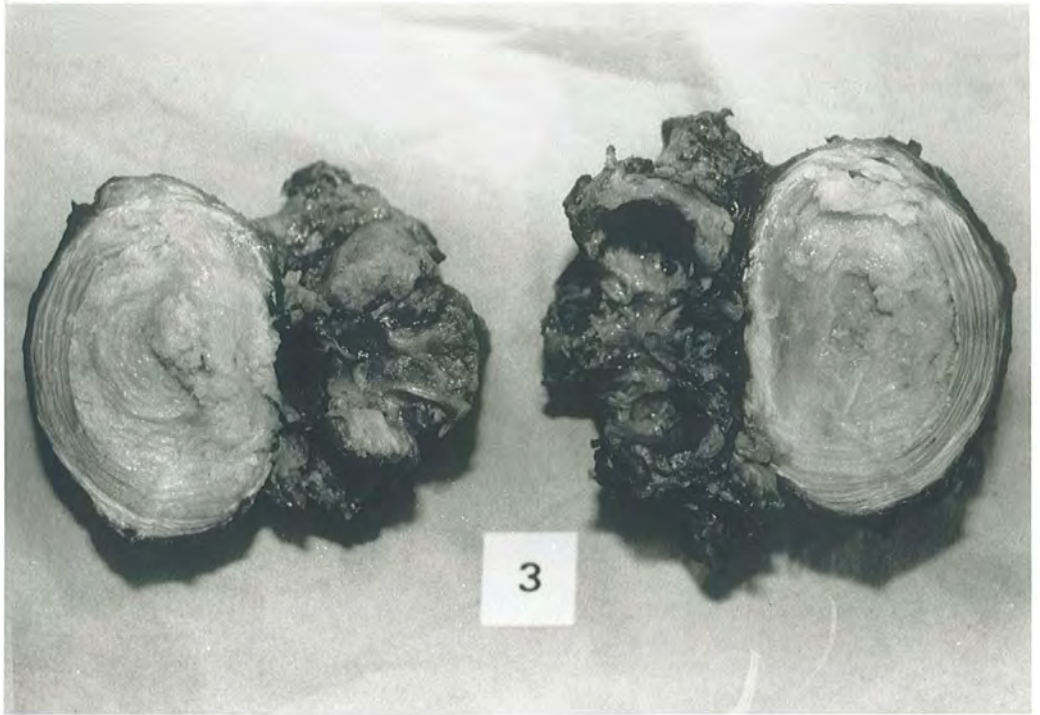

Figure 3.18 — Specimen 3

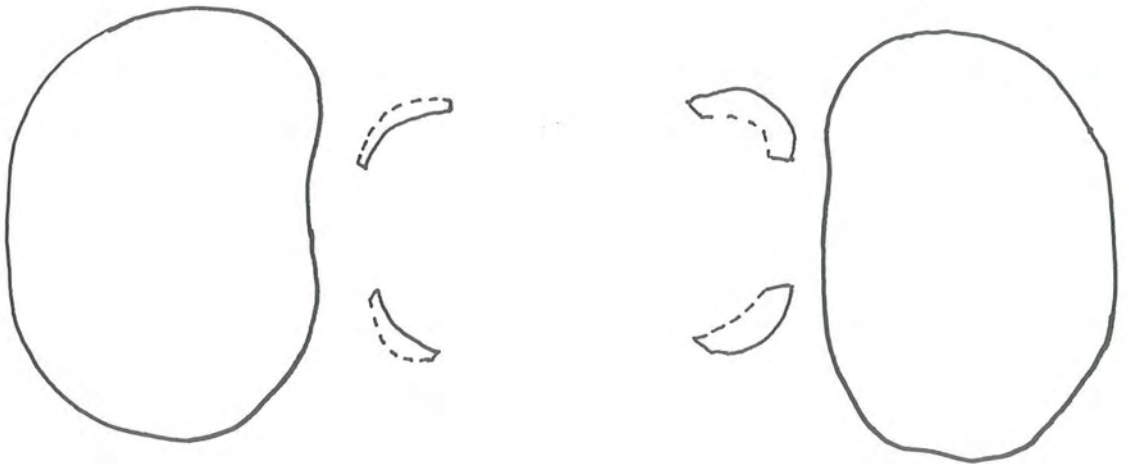

Figure 3.19 — Specimen 4

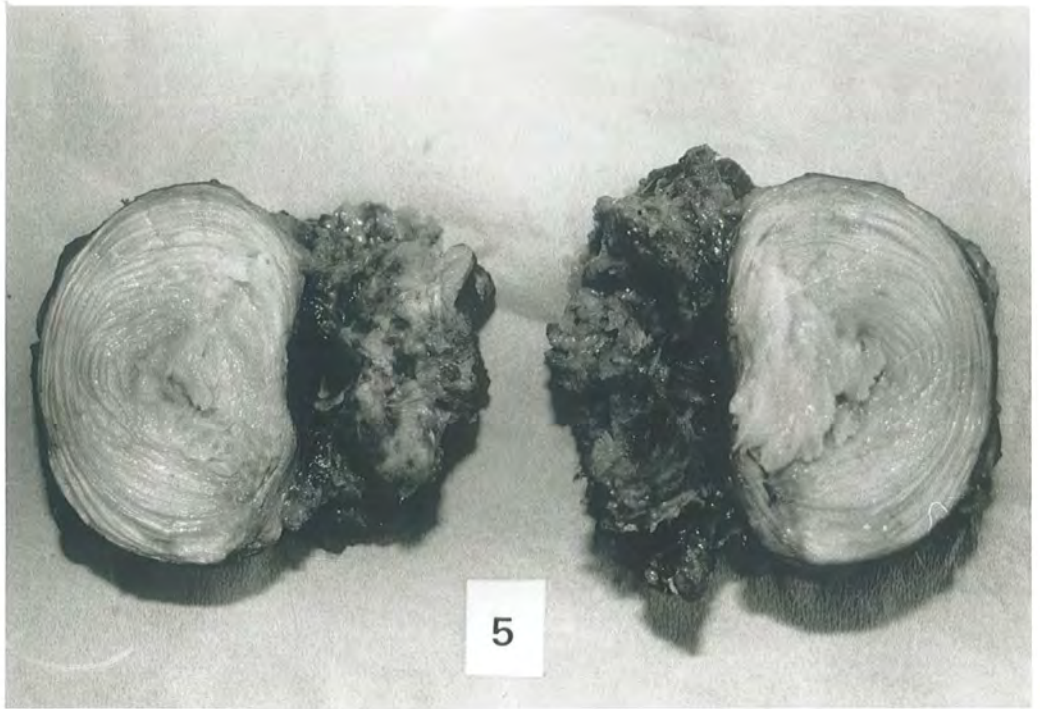

Figure 3.20 — Specimen 5

When tested at both 5° and 10° of flexion specimen 3 showed a bilateral increase in rotation relative to the neutral position, 10° of flexion allowing slightly less rotation than 5°.

Specimen 4 showed a considerable increase in rotation in both the 5° and 10° flexed states to both sides, the joint demonstrating greatest rotation in the most flexed posture.

The results for specimen 5 show the data for the test performed at 10° of flexion to be missing. When tested at 10° of flexion a static hysteresis loop could not be obtained, indicating damage to the specimen, this was confirmed when the specimen was retested in the neutral position. The plot of the joint characteristics tested at 5° of flexion show a considerable increase in rotation and in fact the last portion of this curve to the right begins to show a change in response which may indicate yielding of some part of the joint.

When the first four specimens were retested in the unflexed posture some residual deformation was apparent but the plots showed similar characteristics and remained reproducible.

3.3.4 Discussion

The results indicate that, *in vitro*, some degree of flexion does lead to an increase in available axial rotation in lumbar motion segments.

Specimen 1 only showed an increase in rotation to one side, the right, in the least flexed posture. An examination of Figure 3.16 shows the left zygapophysial joint to be acutely angled, it is certainly noticeably steeper than the right sided joint, suggesting that no increased rotation would be available to this side in

flexed postures. The previous section of this Chapter demonstrated how the posterior spinal ligaments may be responsible for the stiffening of motion segments at high degrees of flexion. The decrease in available rotation shown to be available by this specimen in the most flexed posture is most probably a result of this stiffening. Specimen 3 shows an increase in available rotation in both of the flexed postures but the 5° posture displaying greater movement than the 10° posture. This again could be a result of the stiffening of the posterior soft tissues in this more flexed posture.

Specimens 2, 4 and 5 show increases in available rotation in each flexed posture, where complete data were recorded. These specimens all had relatively "oblique" zygapophysial joints, revealed in Figures 3.17, 3.19 and 3.20, suggesting readily available increased rotation in flexed postures.

The results of these *in vitro* trials have shown similar results to the *in vivo* twisting studies.

3.4 Conclusions

The conclusion of this section of the thesis is that when subjected to some degree of sagittal flexion, *in vitro*, lumbar motion segments have greater available axial rotation than in unflexed postures and that in more extreme angles of flexion the tightening of the posterior ligaments limits rotation.

Chapter IV

Normal Movements

4.1 Introduction

The initial brief of this project was to develop a non-invasive and three-dimensional measurement system for the clinical assessment of spinal motion. The 3SPACE Isotrak has been used successfully in a study of twisting in flexed postures and it was considered to have demonstrated sufficient potential during that study to go forward to be used in a clinical trial. This chapter describes the collection of a data base of normal subjects prior to the measurement of patients. This serves two purposes; first it allows an objective assessment of the 3SPACE Isotrak and its ability to record ranges and patterns of movement in a large population and second, the normal group can act as the control group for future patient studies.

4.2 Subjects

The movements of 80 individuals, 40 male and 40 female, with 10 in each of the four age ranges 20-29, 30-39, 40-49 and over 50 years were recorded. Details of the ages of subjects are given in Table 4.1.

Males					Females			
n	20-29	30-39	40-49	50+	20-29	30-39	40-49	50+
1	26	35	43	55	21	31	44	54
2	22	37	40	53	23	39	46	50
3	25	36	49	65	21	32	44	52
4	27	32	45	59	28	36	41	54
5	28	32	45	57	28	38	43	53
6	26	35	41	58	25	38	42	56
7	20	32	44	53	26	33	45	57
8	26	38	42	64	23	32	46	53
9	29	39	40	55	24	30	43	51
10	27	38	40	59	26	30	40	51
Mean	25.6	35.4	42.9	58.0	24.5	33.9	43.4	53.1

Table 4.1 — Normal Subject Age Details

The normal study was conducted over a period of 11 months. The bulk of the male subjects measured were volunteers from within the School of Engineering and Applied Science at the University of Durham. The majority of female subjects were volunteers from among the staff of Middlesbrough General Hospital.

The term "normal" is somewhat inappropriate when discussing backs. As was mentioned at the start of the thesis most individuals will suffer from some low back pain during the course of their adult lives (Roland 1983). If everyone who had experienced any back trouble was excluded from the study there would

have been great difficulty in completing the sample, especially in the older age groups. Bearing this in mind the criteria for subjects to be acceptable was that they should have been free from low back pain for the previous six months and should not have undergone spinal surgery at any time.

4.3 Procedure, Data Analysis and Statistics

The basic procedure for measurement remained the same as that described in Chapter 2. After being given an explanation as to the nature of the study and what was going to be required of them subjects performed six movements; flexion and extension, extension and flexion, axial rotation to both right and left, starting to each side in turn, and lateral bend to both sides, starting to left and right in turn.

When measurements were required to be made outside of the laboratory the 3SPACE Isotrak was transported in a specially constructed carrying case and a small "lap top "personal computer was used for its control and data collection, as this was more practical to transport.

The method by which the three angles of flexion-extension, lateral bend and axial rotation were obtained from the 3x3 matrix of direction cosines for each movement was described earlier. Once in this form various analyses of the data could take place.

A number of computer programs, written in BASIC, were developed to assist with the display and analysis of results. A program was written (RPROG.BAS, Appendix A) that plotted the three angles against time, Figure 4.1 displays an example of the type of plot produced.

X-AXIS ONE DIVISION=1 Second
Y-AXIS ONE DIVISION=10 Degrees

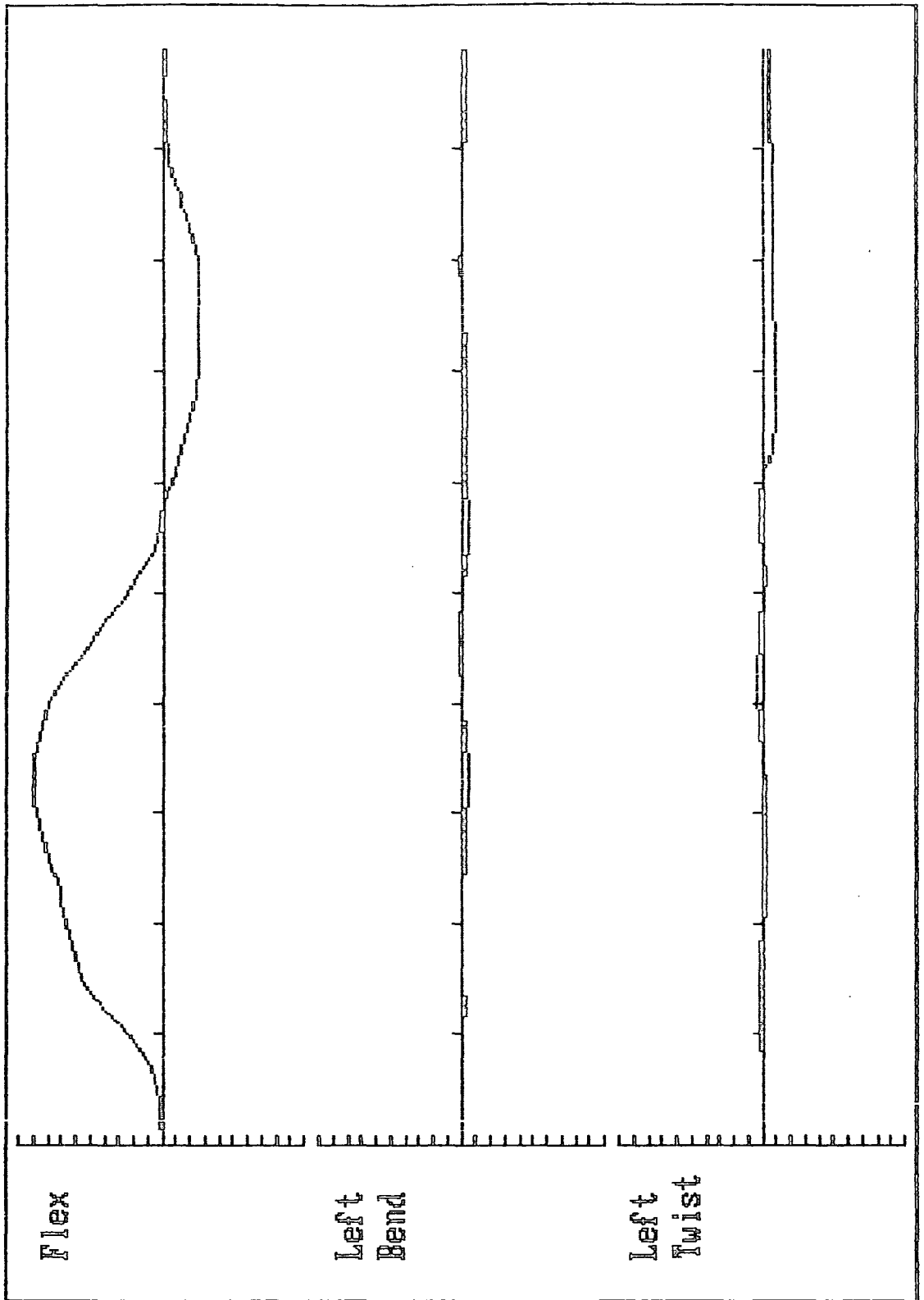

Figure 4.1 — A Subject Performing Flexion and Extension.

In order to compare the kinematic movement patterns of two, or more, individuals one could overlay the individual plots onto the same graph. However, every individual performs a particular movement at a different speed and so the movements of interest will occur at different points along the plot. This makes any comparison difficult. It, therefore, became necessary to normalise each plot. This was achieved with the use of another program (NORPLT.BAS, Appendix A). This program was not written as part of this thesis but is included for reference.

This program produced a normalised plot of a subject's movement that placed the maximum and minimum of the primary movement, flexion and extension for example, at the 25th and 75th points along the time axis respectively. The cross-over between movements was also scaled to occur at the 50th point along the time axis. It also provided an angular value for each of the new data points, doing this by using a linear interpolation between the original data points. The plot of the subject performing flexion and extension that was shown in Figure 4.1 is shown normalised in Figure 4.2, it can be noted that the normalisation does not alter the general shape of the curve. The curves for the associated lateral bend and axial rotation are normalised according to the interpolation of the primary movements. This program did tend to have the effect of producing an unnatural final portion of the curve, since most subjects tended to finish each movement before the end of the ten second period. Since this occurs after the movements of interest have been displayed it was not a significant disadvantage.

When lateral bend or axial rotation were the primary movements then maximum left bend or left rotation was placed at point 25 and maximum right bend or right rotation at point 75.

X-AXIS ONE DIVISION = 1 Second
Y-AXIS ONE DIVISION = 10 Degrees

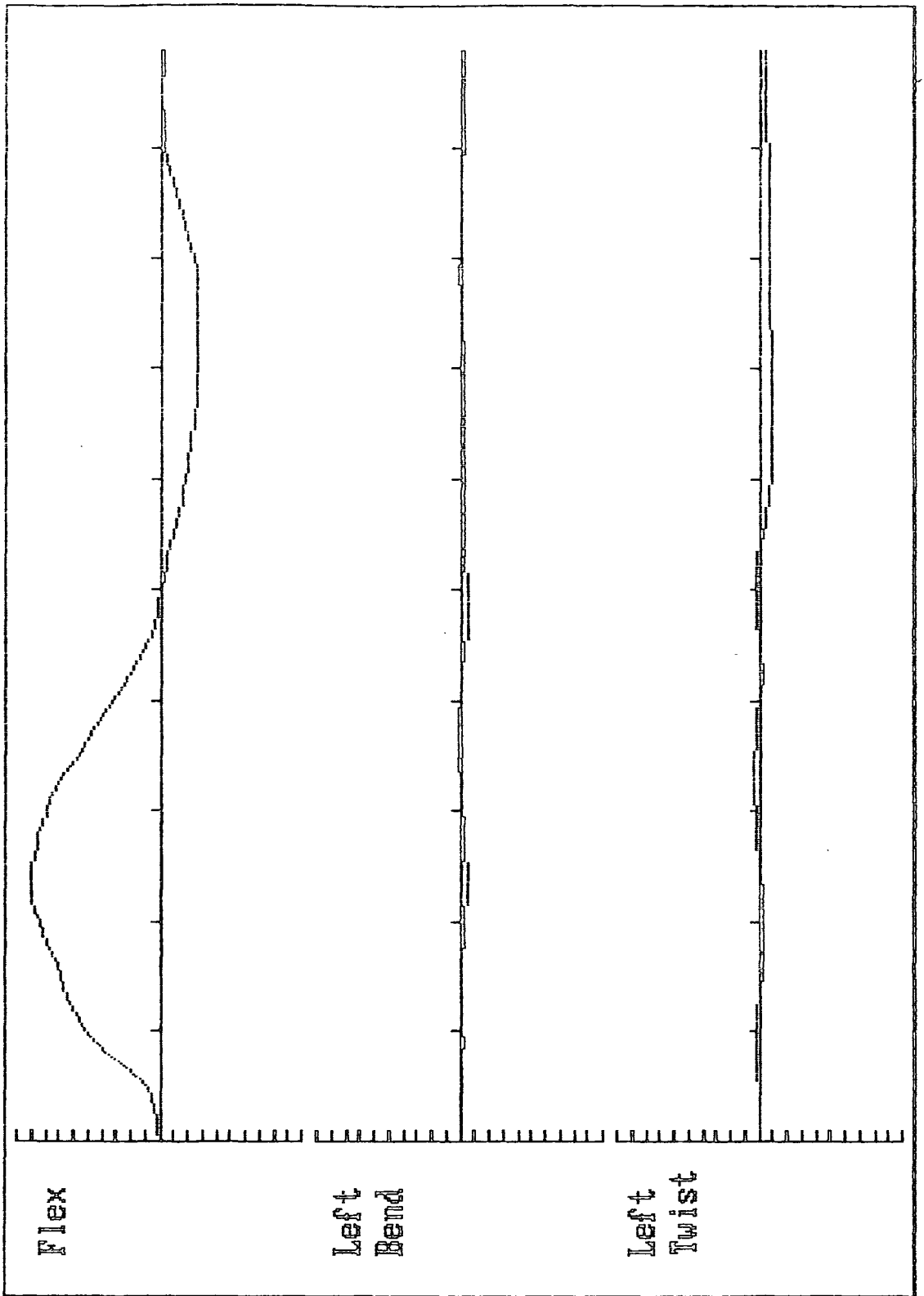

Figure 4.2 — A Normalised Plot of a Subject Performing Flexion and Extension

Two individuals could now be compared when performing the same movement. In order to be able to compare two groups of individuals it was necessary to produce a mean curve of a group of subjects' movements. The program MEAN-PLT.BAS (Appendix A) was used to achieve this, again included for reference. This program calculated the mean value and ± 2 standard deviations at each point along the time axis of however many individuals' movements were considered, this data was then saved to a file and a plot produced. Figure 4.3 shows a plot of a group of ten individuals performing flexion and extension produced in this manner.

It was now possible to compare two groups, or two individuals, performing the same movement subjectively, however no statistical conclusions could be drawn from any apparent differences observed. It would be simple enough to perform statistics for differences at the maximum movements, however it was more desirable to be able to analyse the whole of the movement. Another program (TPLOT.BAS, Appendix A) was devised that allowed a full statistical analysis of differences between two kinematic movement plots. This piece of programming performed a paired t-test on each set of data points throughout the whole of the movement. The t-statistic was then plotted out for each of the three movements along with the level of significance desired. In this way it could be seen if any significant differences existed between the two groups of interest and where these differences occurred. Figures 4.4 and 4.5 show the two mean plots of ten 20-29 males and ten 20-29 females performing flexion and extension and the t-statistic plotted out showing the differences between these two groups with a significance level of 95%.

Figure 4.4 shows the male group to display greater flexion than the females

X-AXIS ONE DIVISION=1 Second
Y-AXIS ONE DIVISION=10 Degrees

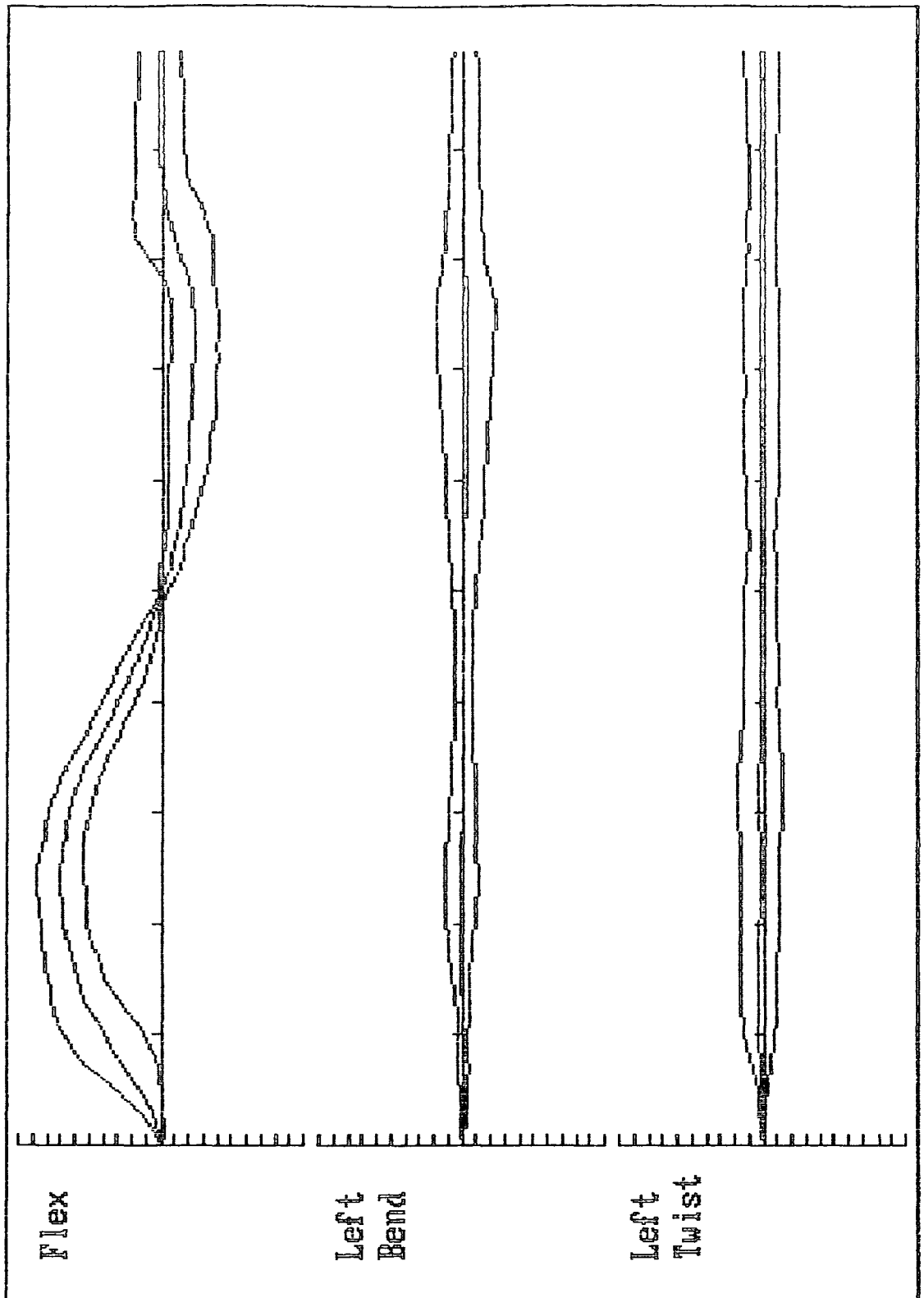

Figure 4.3 — Ten 20-29 Year Old Subjects Performing Flexion and Extension

X-AXIS ONE DIVISION=1 Second
Y-AXIS ONE DIVISION=10 Degrees

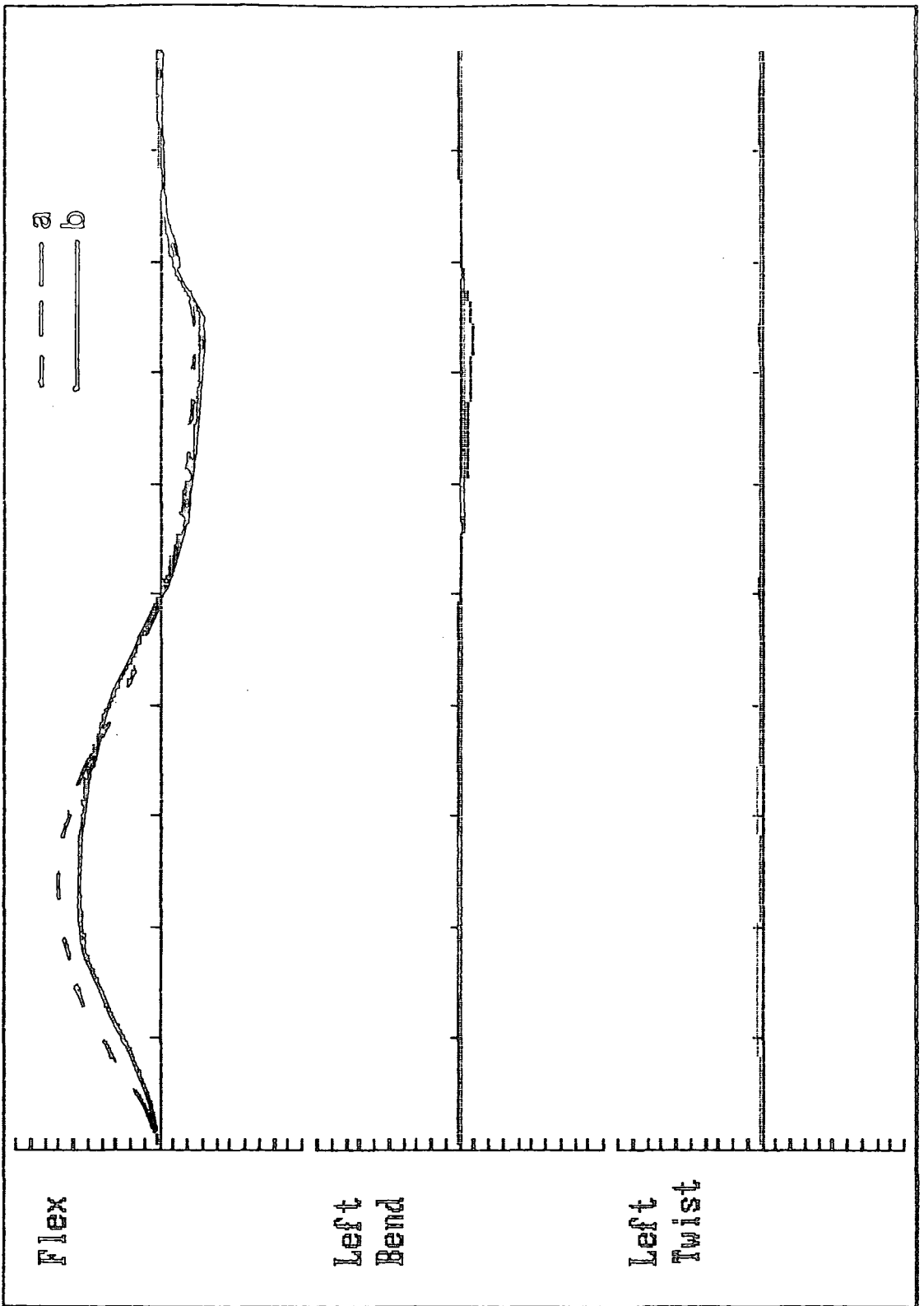

Figure 4.4 — The Mean Plots of Flexion and Extension for (a) Ten 20-29 Males and (b) Ten 20-29 Females

X-AXIS ONE DIVISION=1 SECOND
Y-AXIS ONE DIVISION=5 PTS OF T-DISTRIBUTION

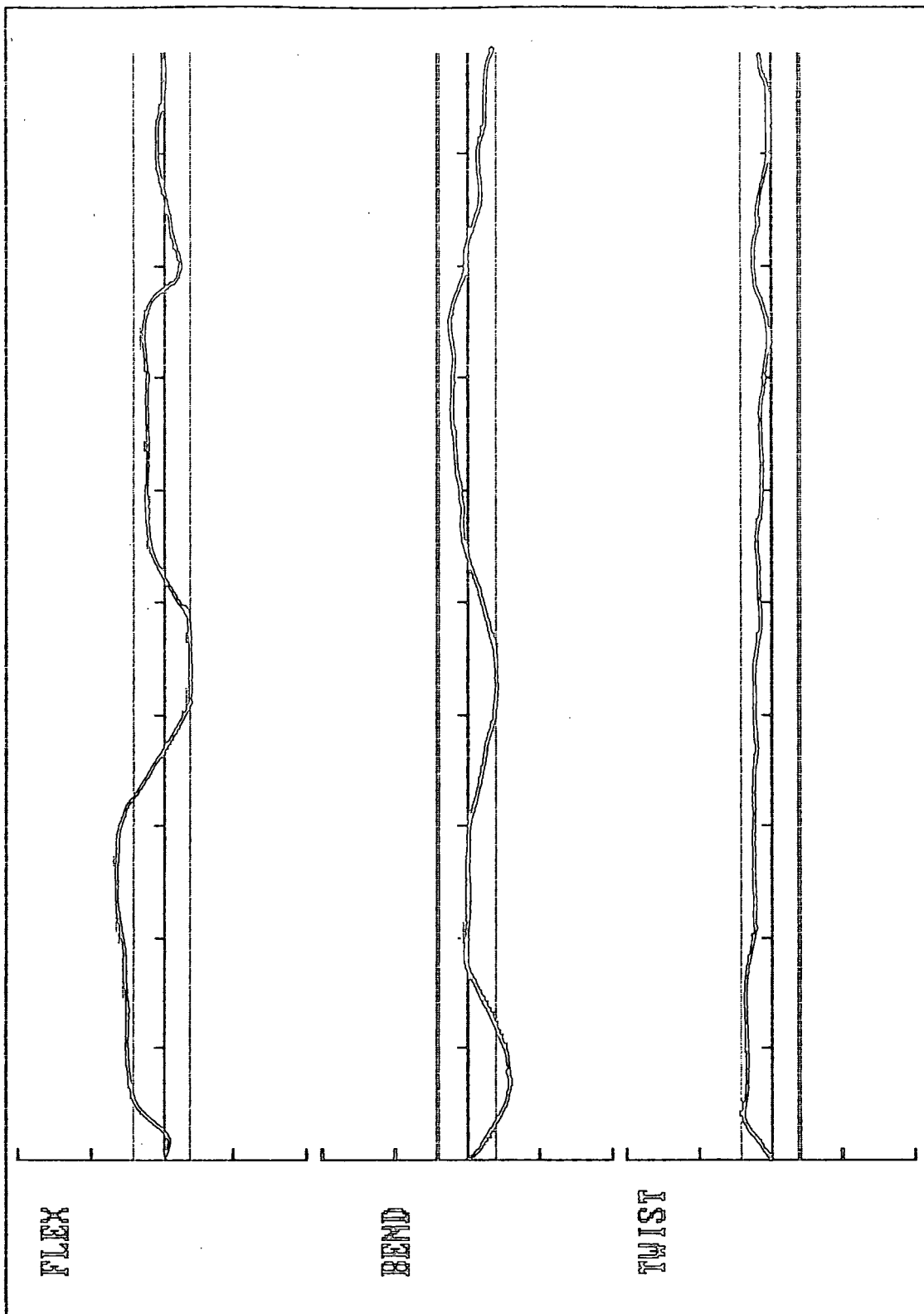

Figure 4.5 — The t-Statistic Showing the Differences Between Groups
(a) and (b) at the 95% Level

and Figure 4.5 demonstrates that this difference was significant at the 95% level.

4.4 Results

The results are presented in three stages; ranges of maximum movements, patterns of kinematic movements and coupled movements.

4.5 Ranges of Movement

Ranges of maximum voluntary flexion, extension, lateral bend and axial rotation for each of the eight sample groups are displayed in Table 4.2. The values have been adjusted according to the regression equation presented previously and therefore represent true angles.

When performing lateral bend and axial rotation there was large scale individual variation concerning the magnitude to which each movement was performed to left and right. However analysis (Paired t-test) showed there to be no consistent difference between left and right bend and left and right twist. Hence in Table 4.2, although sagittal plane movement is divided into flexion and extension, lateral bend and axial rotation are presented as the sum of the movements to left and right.

Sex	Age Group	Flexion (°)	Extension (°)	Lateral Bend (°)	Axial Rotation (°)
Male	20-29	74.61	26.01	57.85	30.33
	30-39	73.23	16.70	53.01	30.04
	40-49	77.24	23.46	47.37	29.07
	50+	70.12	19.44	37.52	21.06
Female	20-29	59.41	31.60	61.91	31.80
	30-39	70.25	23.95	53.58	25.75
	40-49	64.02	19.75	52.79	36.56
	50+	72.96	21.08	50.49	29.25

Table 4.2 — Ranges of Maximum Voluntary Movements

4.5.1 Analysis of Differences in Ranges of Movement Between Sexes

The ranges of movement of all males and all females are displayed in Table 4.3.

Sex	Flexion (°)	Extension (°)	Lateral Bend (°)	Axial Rotation (°)
Male	73.8	21.48	48.44	27.11
Female	66.67	24.10	54.10	30.84

Table 4.3 — Ranges of Movement in Males and Females

Table 4.3 clearly shows males to have greater flexion but females to display more extension, lateral bend and axial rotation than their male counterparts. Analysis of variance (ANOVA) was employed to test these differences for significance and the results of this analysis are summarised in Table 4.4, where M indicates males and F female. It shows that only in flexion was there any significant difference between males and females, with males having significantly more flexion than females.

Movement	Significance
Flexion	$M > F, p < 0.025$
Extension	N.S. *
Bend	N.S.
Twist	N.S.

Table 4.4 — ANOVA Summary Table for Sex Differences

4.5.2 Analysis of Differences in Ranges of Movement Between Ages

The effect of age upon ranges of maximum voluntary movement is illustrated in Table 4.2. It shows a general trend for decreasing movement with advancing age in all movements except flexion in the female groups, where there does appear to be a trend for increasing flexion with age. Only in lateral bend, for both sexes, is a consistent reduction in motion seen in each decade age group.

The ANOVA analysis used above was also able to test for significant differences in the ranges of movement between age groups. A summary of the results are shown in Table 4.5 (Y=young and O=old).

*In this case and in all subsequent cases when the test is non-significant, it is at the 95% level.

Movement	Significance
Flexion	N.S.
Extension	$Y > O, p < 0.05$
Bend	$Y > O, p < 0.025$
Twist	N.S.

Table 4.5 — ANOVA Summary Table for Differences Between Ages

This analysis confirms that the trend displayed in lateral bend is, indeed, significant. It also shows extension to be significantly reduced with age. No significant differences were observed in flexion or twist.

Regression analysis was then carried out to determine the relationship between the age and the range of movement of a subject. The regression plots are to be found in Appendix B. A summary of the results of this analysis is indicated in Table 4.6.

The table shows poor relationship between age and flexion, especially in the female group where the correlation coefficient of 0.339 indicates an increase in flexion with advancing age. For all other movements, apart from axial rotation in females, the negative coefficients indicate a reduction of movement with age. The strongest relationship is seen to occur with lateral bend where $r_{xy} = -0.423$ for all subjects.

Group	Movement Performed	r_{xy}
Males	Flexion	-0.097
	Extension	-0.298
	Lateral Bend	-0.351
	Axial Rotation	-0.291
Females	Flexion	0.339
	Extension	-0.330
	Lateral Bend	-0.249
	Axial Rotation	0.067
All Subjects	Flexion	0.106
	Extension	-0.311
	Lateral Bend	-0.423
	Axial Rotation	-1.109

Table 4.6 — Correlation Coefficients for Age on Movement

There appear to be no consistent differences in the reduction of motion with age between the sexes apart from flexion which is reduced, although not significantly, in males with increasing age but increases, again not significantly, in females. The ANOVA employed earlier indicated no significant sex/age combination effect for any of the movements.

4.6 Kinematic Results

Plots of the mean movements, shown with \pm two standard deviations, for the eight normal subject groups are shown in Appendix C. Figures 4.6, 4.7 and

4.8 show plots of the mean movements of all 80 normal subjects performing flexion and extension, lateral bend and axial rotation. Although significant age and sex effects were demonstrated to exist in the previous sections the grouping together of all normals in this manner does allow the kinematic movement patterns, common to all groups, to be seen.

During both flexion and extension no appreciable lateral bend or axial rotation are seen, the mean values of these two movements remaining close to zero. During lateral bend a significant degree of opposite axial rotation is seen to occur, flexion is also seen to accompany the lateral bend to both sides. During axial rotation opposite lateral bend is seen to occur but there is no consistent pattern of accompanying flexion or extension. These coupled movements are discussed in more detail later.

4.6.1 Analysis of Differences in Kinematics between the Sexes

The TPLOT.BAS program was used to examine differences between the kinematic patterns of movement of males and females. Each corresponding movement, in each age group, of males and females was compared to each other. A summary of the results of these tests are shown in Table 4.7, indicating the significant differences that occurred between the kinematic movement patterns of the sexes.

80 NORMAL SUBJECTS FLEXING AND EXTENDING

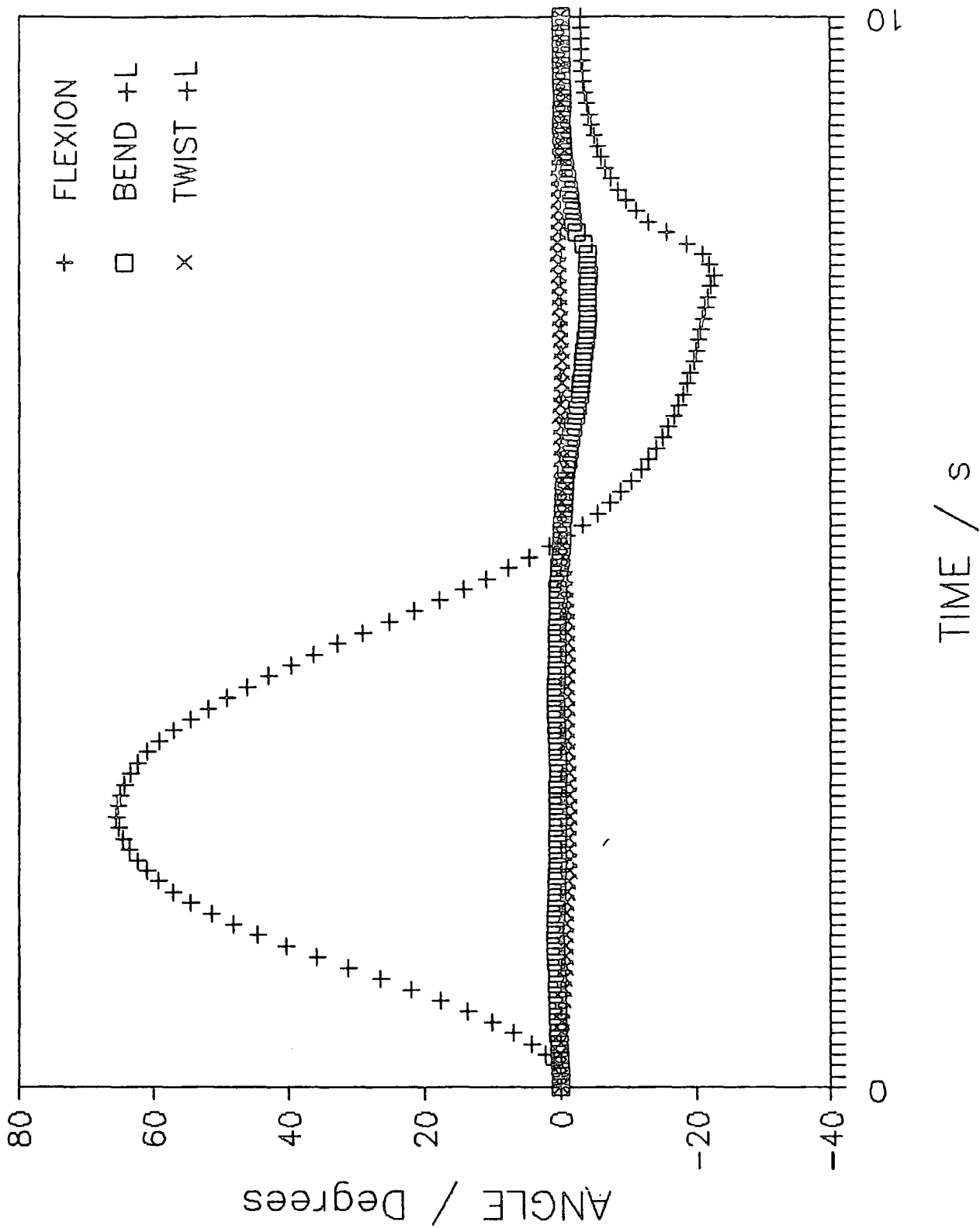

Figure 4.6 — A Plot of 80 Normals Performing Flexion and Extension

80 NORMALS PERFORMING LATERAL BEND

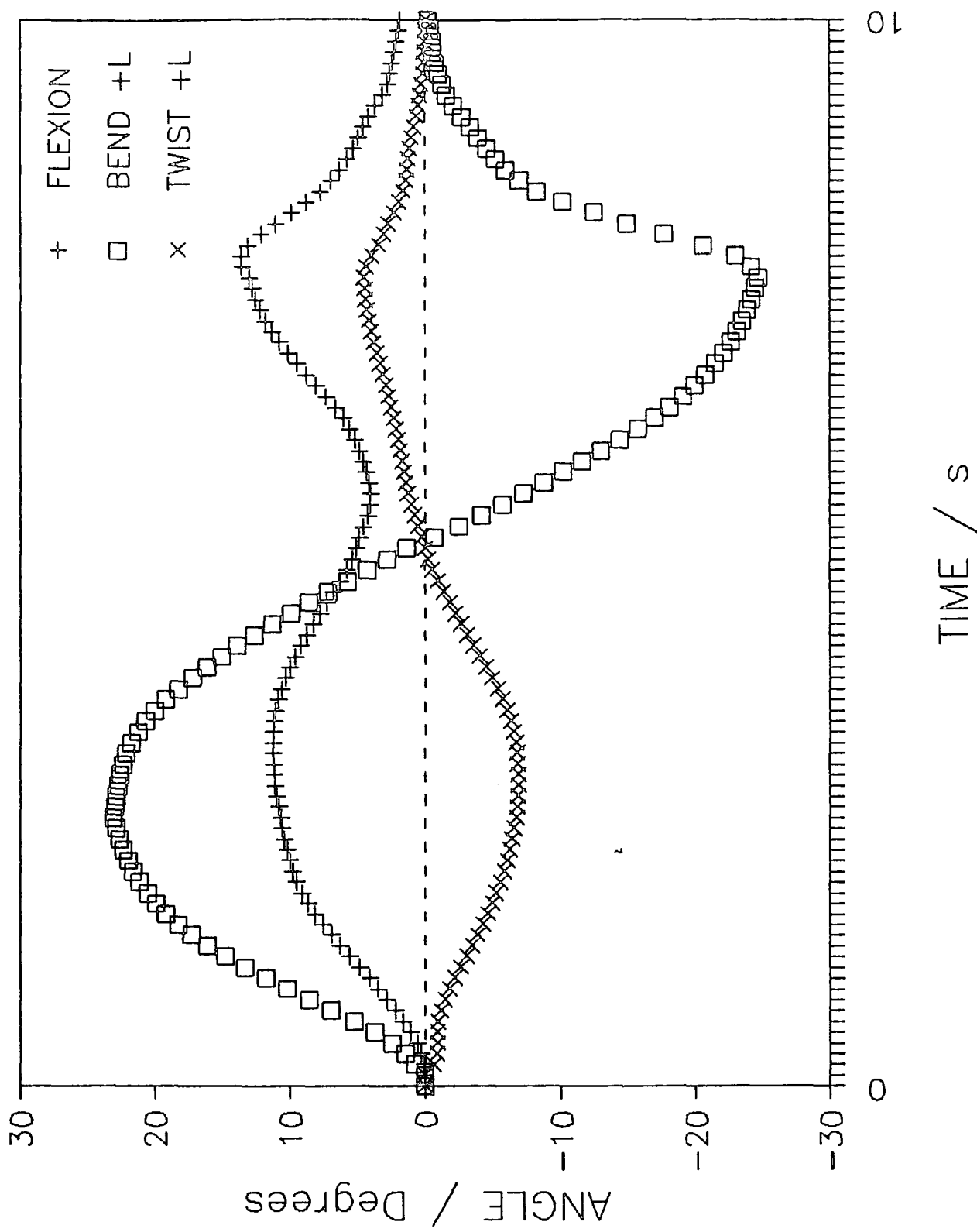

Figure 4.7 — A Plot of 80 Normals Performing Lateral Bend

80 NORMALS PERFORMING AXIAL ROTATION

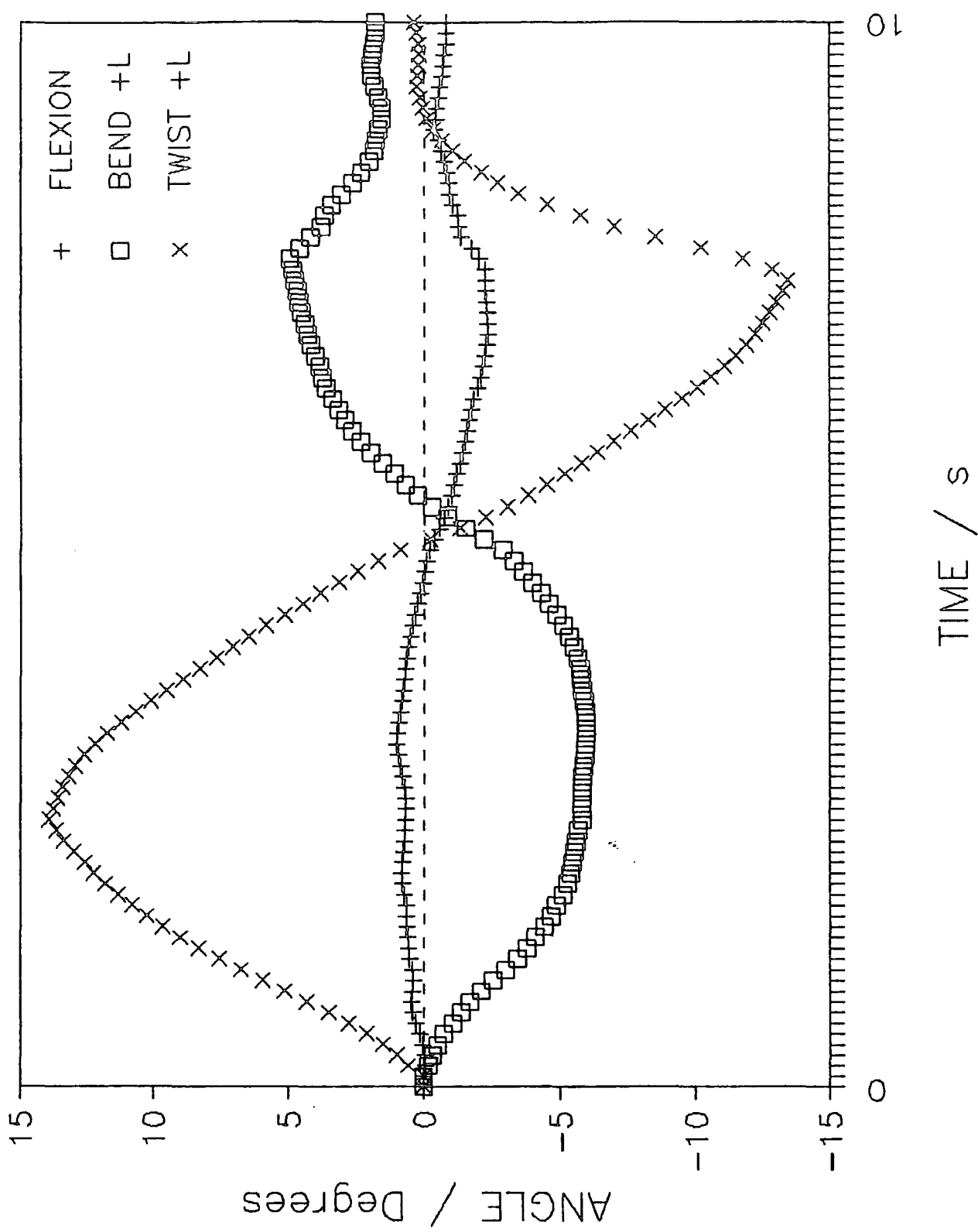

Figure 4.8 — A Plot of 80 Normals Performing Axial Rotation

Groups Tested	Movement Performed	Difference	Movements	Significance
20-29yrs	Flex-ext	M>F	Flexion	p< 0.005
	Bend	M>F	Flexion	p< 0.05
	Twist	F>M	R Bend	p< 0.05
30-39yrs	Bend	F>M	R Twist	p< 0.05
	Twist	F>M	R Bend	p< 0.05
40-49yrs	Flex-ext	M>F	Flexion	p< 0.025
	Bend	F>M	L Bend	p< 0.05
		F>M	Flexion	p< 0.05
50+ yrs	Bend	F>M	R Bend	p< 0.05

Table 4.7 — Significant Differences from t-tests between Sexes

The table is best understood with the aid of an example. Consider the 40-49 year age group performing lateral bend. Female mobility is seen to be significantly greater than males in two planes; left bend, the primary movement, and flexion, an associated movement.

The most striking point to emerge from this table is the very significantly greater flexion seen in 20-29 males in comparison to their female counterparts. Another difference to note is that males demonstrate greater flexion than females in every case that significant flexion differences were seen, when flexion was the primary movement. However, females tend to show greater lateral bend and axial rotation than their male counterparts, as was suggested in Table 4.3.

4.6.2 Analysis of Differences in Kinematics between Ages

The TPLOTT.BAS program was employed to look for variation between kinematic movement patterns of different age groups. A summary of results is presented in Tables 4.8 and 4.9.

Age Group	Movement Performed	Difference	Movement	Significance
20-29 and 50+	Flex-Ext	Y>O	Extension	p< 0.05
	Bend	Y>O	L+R Bend	p< 0.01
		Y>O	L Twist	p< 0.01
	Twist	Y>O	R Twist	p< 0.05
20-29 and 40-49	Bend	Y>O	R+L Bend	p< 0.05
		Y>O	R+L Twist	p< 0.05
	Twist	Y>O	L Bend	p< 0.05
20-29 and 30-39	Bend	Y>O	L+R Twist	p< 0.05
30-39 and 50+	Bend	Y> O	L+R Bend	p< 0.05
40-50 and 50+	Bend	Y>O	R Bend	p< 0.05
		Y> O	L Twist	p< 0.05

Table 4.8 — Significant Differences from t-tests between Ages in Males

Age Group	Movement Performed	Difference	Movement	Significance
20-29 and 50+	Flex-Ext	Y > O	Extension	p < 0.05
		O > Y	Flexion	p < 0.05
	Twist	O > Y	L Twist	p < 0.05
		O > Y	R Bend	p < 0.05
20-29 and 40-49	Flex-Ext	Y > O	Extension	p < 0.05
	Bend	Y > O	R+L Bend	p < 0.05
		Y > O	R+L Twist	p < 0.05
	Twist	Y > O	R Bend	p < 0.05
20-29 and 30-39	Twist	Y > O	L Twist	p < 0.05
		Y > O	R Bend	p < 0.05
30-39 and 50+	Bend	Y > O	L Bend	p < 0.05
		Y > O	R Twist	p < 0.05
30-39 and 40-49	Twist	O > Y	R+L Twist	p < 0.05
40-49 and 50+	Bend	Y > O	Flexion	p < 0.05
		Y > O	L Twist	p < 0.05

Table 4.9 — Significant Differences from t-tests between Ages in Females

The overall impression one gets from these two tables is a clear decrease in mobility with advancing age. The only exceptions to this occur in the female group where the 50+ age group are seen to exceed the 20-29 age group in flexion. Interestingly the younger age group demonstrate significantly higher extension

so that the total range of flexion and extension was approximately the same in both groups and this suggests that lumbar lordosis increases with age in females. The older age group also show increased left twist and coupled right bend when performing axial rotation.

4.7 Coupling

The phenomenon of coupling of lumbar intervertebral movements was discussed in Chapter 1. Subjectively a strong coupling of opposite axial rotation upon lateral bend and *vice versa* can be seen by examining Figures 4.7, 4.8 and the plots of these two movements contained in Appendix C, as was noted previously. Chi-Squared tests were carried out to confirm this statistically, the results of which are shown in Table 4.10.

The analysis confirms a very strong coupling of opposite axial rotation on lateral bend and of opposite lateral bend on axial rotation. It also shows a strong coupling of flexion occurring with lateral bend, confirming the subjective impression one gets when viewing the plots of subjects performing lateral bend. No significant coupling, however, is seen between axial rotation and any sagittal plane movement.

Coupled Movements	Significance
R Twist on L Bend.	sig, $p < 0.001$
L Twist on R Bend	sig, $p < 0.001$
R Bend on L Twist	sig, $p < 0.001$
L Bend on R Twist	sig, $p < 0.001$
Flexion on Bend	sig, $p < 0.001$
Flexion on Twist	N.S.

Table 4.10 — Results of the Chi-Squared Analysis of Coupled Movements

Regression analysis was then performed to establish the strength of this coupling. Tables 4.11 and 4.12 display a summary of the results for the regression analysis demonstrating the strength of coupling between lateral bend and axial rotation and *vice versa*, they show the results for the youngest and oldest age groups and for all age groups.

Coupled Movements	Age Group	Male	Female
R Bend on L Twist	20-29	-0.112	-0.575
	50+	-0.673	-0.362
	All	-0.482	-0.455
L Bend on R Twist	20-29	0.186	0.655
	50+	0.231	0.795
	All	0.358	0.617

Table 4.11 — Correlation Coefficients (r_{xy}) Showing the Strength of Coupled Lateral Bend on Axial Rotation

Coupled Movements	Age Group	Male	Female
R Twist on L bend	20-29	-0.38	-0.789
	50+	-0.875	-0.221
	All	-0.572	-0.468
L Twist on R Bend	20-29	0.644	0.693
	50+	0.188	0.252
	All	0.466	0.381

Table 4.12 — Correlation Coefficients (r_{xy}) showing the strength of Coupled Axial Rotation on Lateral Bend

Some correlation coefficients are seen to be negative and others positive, this is as a result of the initial movements being labelled negative or positive depending on whether they occurred to right or left respectively. The magnitudes of the coefficients for all age groups ranges from 0.358 to 0.617 reflecting a reasonably strong correlation between the magnitude of the primary movement and the magnitude of the coupled movement. A good deal of variation can be seen between the youngest and oldest age groups, in some cases the 20-29 age group display better correlation than the 50+ age group and in other cases the situation is reversed, no consistent trends, however, are revealed. There appear to be no differences between the sexes.

Table 4.13 displays the results of the regression analysis demonstrating the strength of coupling of flexion occurring on lateral bend.

Coupled Movement	Age Group	Male	Female
Flexion on L Bend	20-29	-0.124	-0.450
	50+	0.569	-0.278
	All	0.139	-0.129
Flexion on R Bend	20-29	-0.221	-0.358
	50+	0.537	-0.237
	All	-0.078	-0.352

Table 4.13 — Correlation Coefficients (r_{xy}) showing the Strength of Coupling between Lateral Bend and Flexion

These results indicate that, although it has been shown that a significant coupling of flexion with lateral bend does occur, there is little relation between the magnitude of the primary movement, lateral bend, and the magnitude of the coupled flexion. Again no real trends are seen with respect to age and sex differences.

Despite the uncertainty of the effects of age upon the strength of coupling observed a reference to Tables 4.8 and 4.9 will reveal that coupled movements tend to be affected in the same manner as the primary movements, being reduced with age.

4.8 Discussion

Various workers have presented ranges of lumbar motion, in normals, using a variety of the techniques reviewed in Chapter 1. A comparison of the results of this study with any of these would be inappropriate, given their respective

limitations. Pearcy (1985) has given us the best and most comprehensive picture of the actual three-dimensional movements of the lumbar spine so a comparison with his data will give an indication of the 3SPACE Isotrak's ability to measure true lumbar spinal motion. A comparison of the two sets of data is shown in Table 4.14.

The data for the 3SPACE Isotrak have been corrected according to the regression equation mentioned previously. Pearcy's data was of an all male population with 11 subjects tested in flexion-extension (mean age 29 years) and 10 each in lateral bend and axial rotation (mean ages 24 and 28 years respectively). Therefore only the 10 males from the 20-29 age group (mean age 25.6 years) have been included from the results of the 3SPACE study.

The data clearly indicates that the 3SPACE Isotrak provides ranges of motion in excess of those known to occur in healthy individuals. The exaggeration of true lumbar movement resulting from the attachment of markers to the skin was discussed earlier. Inevitably, with the necessary tethering of the sensor with the strap around the trunk, the 3SPACE Isotrak can only ever claim to give a measure of "low back "mobility which must include some thoracic movement. However, there is no reason to believe that this movement does not give a fair representation of the actual movement of the lumbar spine. Indeed, the patterns and coupling of movements observed in this study compared to those known to occur in the lumbar spine would tend to support this argument.

Movement	3SPACE Isotrak	3-D X-RAY
Flexion	70.2°	51°
Extension	24.3°	16°
Total	94.5°	67°
Left Bend	27.5°	18°
Right Bend	26.8°	17°
Total	54.3°	35°
Left Twist	16.6°	5°
Right Twist	11.6°	4°
Total	28.2°	8°

Table 4.14 — Ranges of Normal Lumbar Motion as Measured by
3SPACE Isotrak and 3-D X-RAY

Precious little information is available concerning the normal kinematic patterns of movement of the lumbar spine outside the work carried out within the Bioengineering Group at Durham. As mentioned above the VICON system was used to look at patterns of movement in six normal individuals. All subjects displayed consistent patterns of movement and Pearcy *et al* (1987a) have shown a strong similarity of these patterns to patterns obtained from Pearcy's (1985) radiographic studies, leading them to the conclusion that surface measurements are closely related to the movements of the underlying spine. Typical plots obtained for flexion-extension, lateral bend and axial rotation from the subjects in this study show very good agreement with those obtained from the three-dimensional radiographic study and the VICON study. Plots of one subject repeating the same movement are remarkably consistent (see Figures 2.15 to 2.20).

The subject displays his own unique patterns of movement, even if the magnitude of these movements varies the pattern stays the same. These characteristic plots could be termed "signature" plots for each individual. Not only were patterns similar within individuals but also between them. The plots contained in Appendix B show the similarity in patterns of movement between normal groups, although the ranges of motion may vary markedly, the pattern remains similar.

A number of authors have previously reported age and sex differences with respect to ranges of normal lumbar mobility.

Tanz (1953) noted a decrease in lumbar flexion-extension with age in both males and females. Troup *et al* (1968), however, only found this to occur significantly in males. They also reported that there were no significant differences between the ranges of flexion-extension in the two sexes.

Moll and Wright (1971), in their study of sagittal and lateral plane movements, found there was an initial increase in mean mobility from the 15-24 decade to the 25-34 decade followed by a progressive decrease with advancing age, in both sexes. They found that in extension age could reduce mobility by over 50%. A consistent sex difference was also observed, male mobility exceeding female in the sagittal plane but female exceeding male in lateral bend.

Fitzgerald *et al* (1983) measured lumbar flexion, extension and lateral bend in 172, mainly male, subjects by a combination of goniometry and skin distraction. Their results also demonstrated a significant decrease in lumbar spinal range of motion with advancing age.

Batti'e *et al* (1987) recently conducted a large scale study into spinal flexibility and the factors influencing it. They measured spinal flexibility in the sagittal

plane using the modified Schober technique and in the frontal plane by assessing the position of the fingertips in the erect and bending postures, in 2,350 male and 670 female subjects. They found both age and sex to be significant factors in the determination of range of motion. They noted that mobility fell with increasing age in both sexes, the rate of decrease in spinal flexion was significantly less for women than for men, a similar finding to Troup *et al* (1968), in side-bending, however, movement decreased equally with age in both sexes.

Burton (1987) also noted that sagittal mobility declined with age in both sexes but that males showed an accelerated decline between youth and middle age. Females consistently displayed greater mobility than males in extension but there were no differences in flexion.

The decrease in mobility with age has also been reported by researchers conducting *in vitro* studies of lumbar spinal motion (Hilton and Ball 1979, Taylor and Twomey 1980).

The results of this study agree broadly with the consensus evidence of these previous studies. A general trend was observed for decreasing mobility with increasing age, the only exception to the trend was the significant increase in sagittal flexion observed with age in the female group. This result would seem to be a consequence of an increase in lordosis with increasing age in the female group, as was noted in the results. There seems to be no obvious reason for this, it may be linked to changes in the hip joints causing an increase in the tilt of the pelvis. The analysis of differences between sexes showed males to have significantly greater flexion than females and females tending to display greater extension, lateral bend and axial rotation than their male counterparts.

Batti'e *et al* (1987) also found spinal range of motion to be affected by not only age and sex but by height, obesity and the ratio of standing to sitting height and suggested that these factors should be considered in assessment of normal ranges of motion, however Burton (1987) found no consistent correlations between sagittal mobility and spinal anthropometry, described by trunk length and lumbar length. This study, compared to those of Batti'e *et al* (1987) and Burton (1987), was small consisting of only 80 individuals split into eight groups by age and sex. An attempt to allow for factors such as height and weight would have been inappropriate in groups of only ten subjects.

The work of Pearcy (1985) on the coupling of intervertebral movements has been discussed previously. The observation of coupled lateral bend with axial rotation and *vice versa* in this study agrees broadly with the coupling Pearcy noted at the intervertebral level. He also found no significant coupling of flexion or extension with axial rotation, however, he noted consistent coupled extension on lateral bend at all levels bar L5-S1. This study showed a consistent coupling of flexion with lateral bend. Pearcy *et al* (1987b) again found this trend for extension coupled with lateral bend during their kinematic studies of back movement using the VICON system, although they did note flexion occurring in three of their subjects, half the sample size, in at least one of the right and left bends. The reason for this discrepancy lies in the experimental technique employed for both the three-dimensional radiographic and the VICON studies; in both cases the subjects were required to stand in frames. This was necessary in the radiographic study to ensure hip motion didn't take the lumbar area out of the field of view and in the VICON study the frame acted to align the subject with the axes of the measurement system. Both frames held the subjects' supe-

rior anterior iliac spines against moulded plastic pads, as indeed was the case in the CODA-3 trial. So positioned a subject's movements are artificially restrained preventing the natural coupling of flexion with lateral bend demonstrated in this study, where they were able to move freely. The VICON study did show opposite axial rotation with lateral bend and *vice versa*. It is reasonable to assume, therefore, that the coupling characteristics demonstrated in this study are a true reflection of those occurring in the normal human back. This of course questions the validity of the whole of Pearcy's data since all tests were performed in the standing frame. However, it would appear that the coupling of flexion with lateral bend was the only movement to be affected significantly as a result of the standing frame. During flexion and extension hip movement was limited but the lumbar spine was unaffected and during axial rotation it has been shown that no coupled flexion-extension occurs.

In summary this normal study has demonstrated that the 3SPACE Isotrak is able to provide ranges of motion of the low back which agree reasonably well with published data. It has also provided valuable information on the kinematic movement and coupling patterns of the low back of normal individuals *in vivo*. Considering the remarkable similarity of kinematic patterns observed across the range of age and sex groups in this study it is reasonable to assume that these may be noticeably affected by pathologic conditions and hence be detected by this system.

4.9 Conclusions

The conclusions of this section of the thesis are thus:

1. The 3SPACE Isotrak is able to record representative ranges and patterns

of motion of the lumbar spine in three-dimensions, kinematically and non-invasively.

2. Ranges of motion, in general, are reduced with increasing age, in both sexes, although in females a significant increase in sagittal flexion was noted with increasing age.
3. Male mobility significantly exceeds female in sagittal flexion but female tends to exceed male in extension, lateral bend and axial rotation.
4. There is a consistent coupling of movements in the normal lumbar spine. Opposite axial rotation occurs upon lateral bend and *vice versa*, flexion also occurs on lateral bend but not on axial rotation.

Chapter V

Clinical Study

5.1 Introduction

The 3SPACE Isotrak has been successfully used in a study of normal kinematic movement patterns of the human back. A preliminary clinical study is now presented, the aims of which are threefold. First, to assess the 3SPACE Isotrak in a clinical setting, second to determine if a relationship exists between movements of the back and pathology and third to comment on the clinical relevance of the measurement of back movement.

5.2 Procedure

Patients were measured in the out-patient clinics of two local orthopaedic surgeons at North Tees General and Sunderland General Hospitals. Patients measured at North Tees General were called into specially arranged clinics where their movements were recorded. At Sunderland General patients' movements were measured during the course of the weekly outpatient clinic, generally after examination by the clinician. The basic measurement procedure remained the same as that described in the collection of normal data for both patient groups. Subsequent to measurement the two surgeons involved completed assessment forms for each patient. A basic list of details required on these forms was drawn up with the surgeons and then each decided on their own format. An example of each of these forms is shown in Appendix D.

5.3 Results

The results of the two patient trials are presented separately.

5.3.1 North Tees General Patient Results

A total of 21 low back pain patients was measured during the course of two specially arranged out-patient clinics. These were all patients awaiting surgery and for whom a definite diagnosis had been reached. Of these original 21 a total of 14 completed assessment forms were provided by the clinician. The results of only these 14 patients are therefore considered. A summary of the information contained on each patient's assessment form is shown in Table 5.1.

The entries for radiating pain and signs of nerve root tension indicate the side responsible; right, left or bilateral. None of the patients had radicular pain or signs of nerve root compression.

Before any consideration was given to pathology or to the clinical assessment of the spinal movements each patient was first compared to normal patterns. Acetate copies were made of the kinematic patterns of movement of the eight normal groups included in Appendix B. These plots, matched for age and sex, could then be overlayed on the plot of a patient's movement. This immediately showed whether a patient's movements were normal and if not gave an indication of the degree of abnormality, since the normal plots have ± 2 standard deviations marked. If a patient's plot fell outside of these then one could say, with 95.4% confidence, that his or her movement was significantly different to normal. This analysis is central to the thesis and so a summary of the assessment of each patient is considered separately in Appendix E where movements are described

Patient	Sex	Age (yrs)	Duration of Symptoms (yrs)	Radiating Pain	Nerve Root Tension	Muscle Spasm	Tender- ness
MK	F	55	20	R	R	Y	
CS	F	42	2	R		N	
JU	F	46	5	R	R	N	
DO	M	32	10	L		Y	L5-S1
MP	F	50	17	B		N	L4-S1
BO	F	51	6	R		N	L5-S1
JM	F	43	7	B		N	
SM	F	52	2	R		N	
NM	M	34	2	R	R	N	
JH	F	43	7	B		N	
EJ	F	52	10	L		N	L5-S1
GG	F	34	5	B		N	
AB	F	47	2	R		N	
VA	F	48	17	R		N	

Table 5.1 — North Tees Patient Details

as being normal (being on or near the mean for that group), restricted (being less than the mean of that group) and very restricted (being outside the two standard deviation range of that group). Mobile and hyper-mobile are used in a similar manner to restricted and very restricted for movements greater than the mean of that group. From these descriptions it is apparent that these patients showed wide spread and marked deviations from normal in both primary and coupled movements.

The diagnosis that was made for each patient is shown in Table 5.2.

Patient	Diagnosis
MK	Facet hypertrophy and arthropathy L5-S1 and L4-5.
CS	Facet arthropathy.
JU	Disc degeneration L5-S1.
DO	Facet arthropathy and central disc prolapse L4-5.
MP	Disc degeneration L4-5 and spondylolisthesis L5.
BO	Disc degeneration and facet arthropathy L4-5.
JM	Bilateral complete spondylolisthesis.
SM	Facet arthropathy.
NM	Central disc protusion and spinal stenosis L4-5.
JH	Facet arthropathy.
EJ	Facet arthropathy L4-5 and L5-S1.
GG	Spondylolisthesis L5 and pseudarthrosis S1.
AB	Spondylolisthesis and facet arthropathy L5.
VA	Collapse L4-5 disc space and facet arthropathy L5-S1 and L3-4.

Table 5.2 — North Tees Patient Diagnoses

As can be seen from this Table there was quite range of pathological conditions present among the patients measured and with such a small sample group it is obviously impossible to delineate subgroups that share exactly the same pathology. However, a number of general groupings can be made. Patients were put into one of three groups, those suffering from facet arthropathy or hypertrophy, disc degeneration or prolapse and spondylolisthesis. Many patients were suffering from more than one specific pathology and these, therefore, were included in more than one group.

A total of nine patients were included in the facet arthropathy group, five in the disc degeneration group and four in the spondylolisthesis group. The kinematic movement patterns of each individual patient have already been compared to matched normal groups.

In order to assess the movement patterns of the patient groups as a whole it was necessary to compare them to movements of all the 80 normal subjects, since the patient groups covered several age ranges and contained both males and females, this would produce a reasonable estimate of the abnormality of their movements. The TPLOTT.BAS program was used to look for differences in kinematic movement patterns between patient groups and normals and between the patient groups themselves.

Figures 5.1, 5.2 and 5.3 show overlaid plots of the mean movements of the 80 normal subjects and the three patient groups performing flexion and extension, lateral bend and axial rotation. Appendix F contains the individual plots of these movements showing the mean and \pm two standard deviations for each movement.

All three of the patient groups showed significant differences from the nor-

NORMAL
 DISC
 SPONDYLOLISTHESIS
 FACET ARTHROPATHY

X-AXIS ONE DIVISION=1 Second
 Y-AXIS ONE DIVISION=5 Degrees

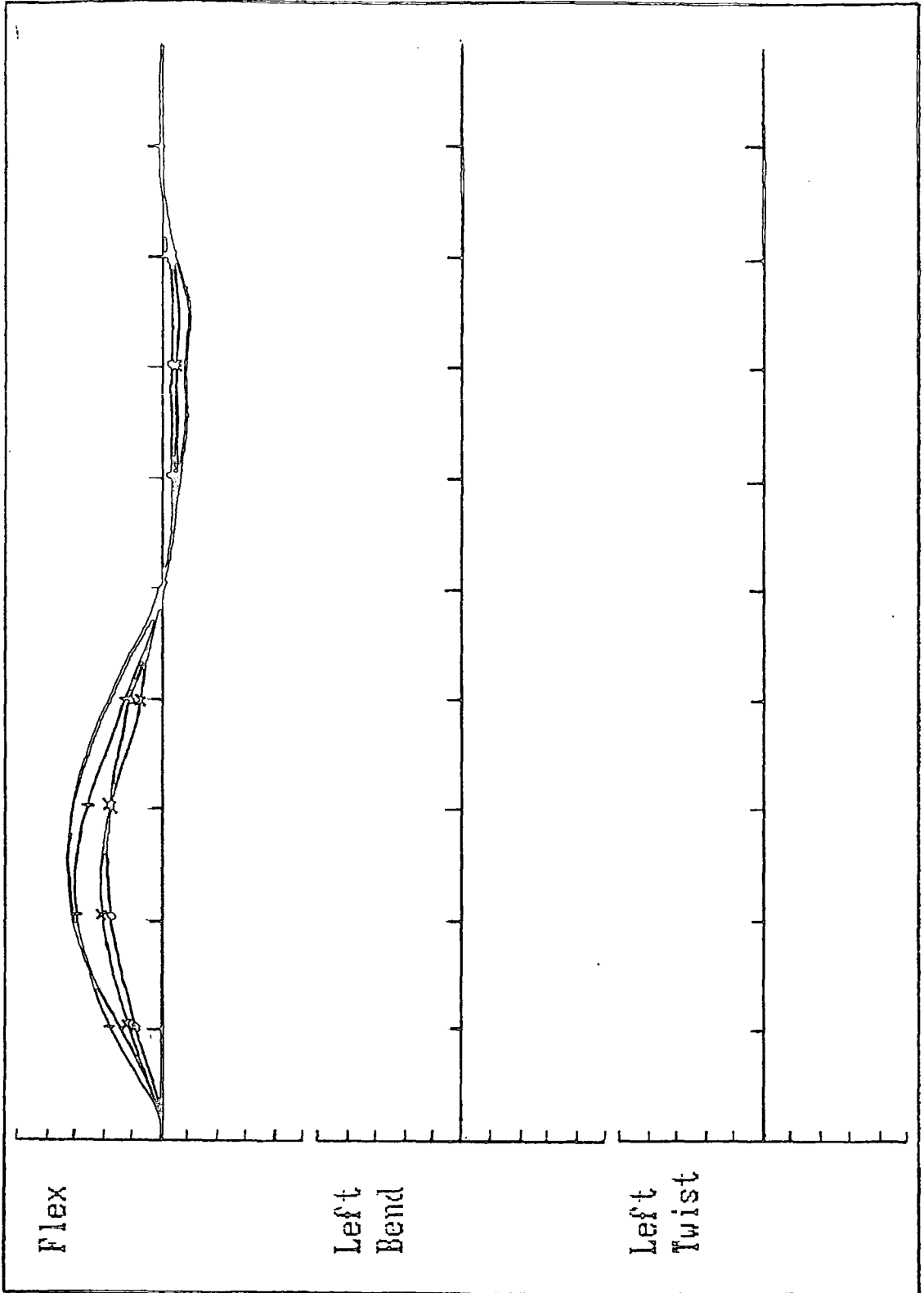

Figure 5.1 — Normal and North Tees Patient Groups Performing Flexion and Extension

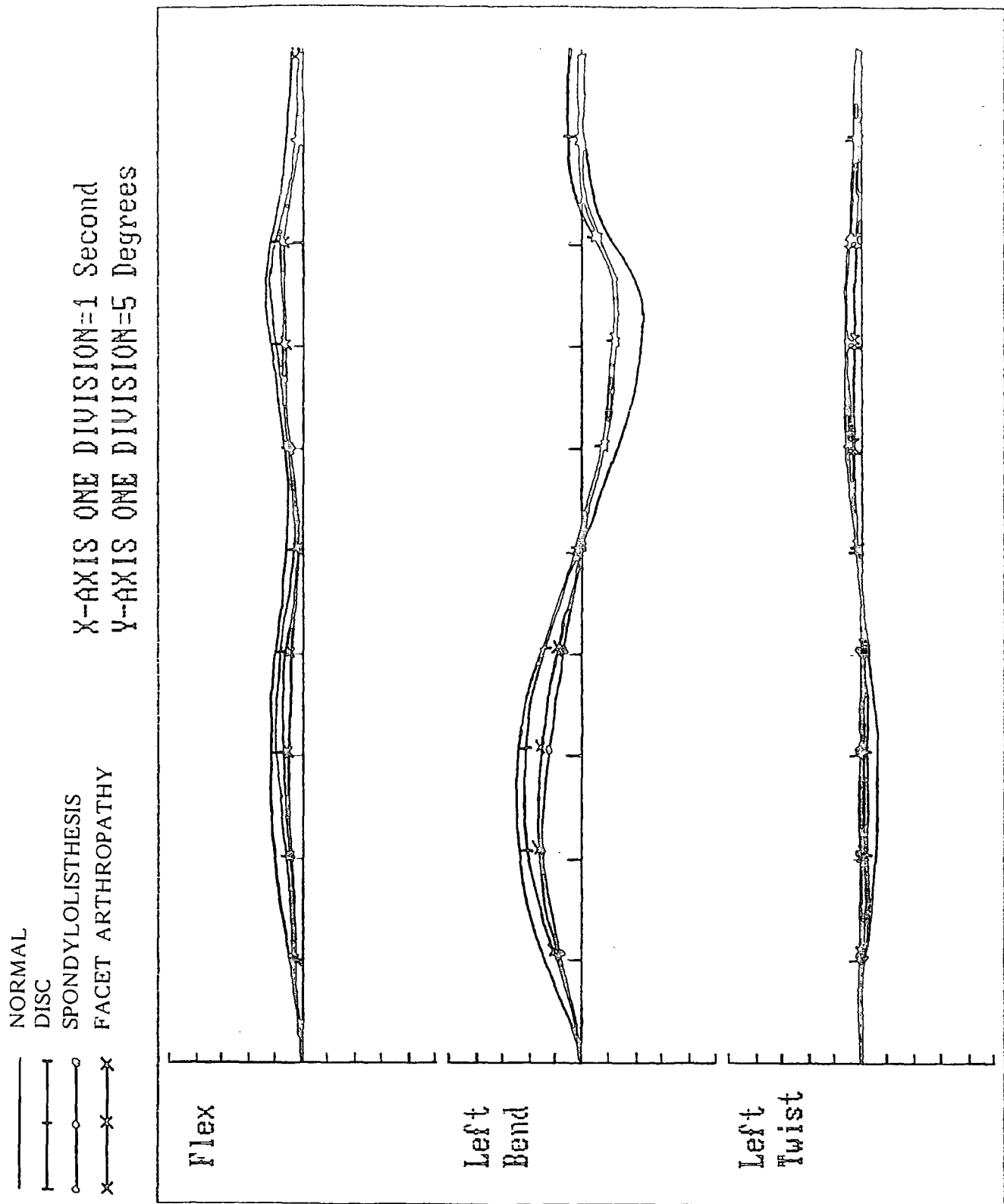

Figure 5.2 — Normal and North Tees Patient Groups Performing Lateral bend

——— NORMAL
 ———+—— DISC
 ———○—— SPONDYLOLISTHESIS
 ———x—— FACET ARTHROPATHY

X-AXIS ONE DIVISION=1 Second
 Y-AXIS ONE DIVISION=5 Degrees

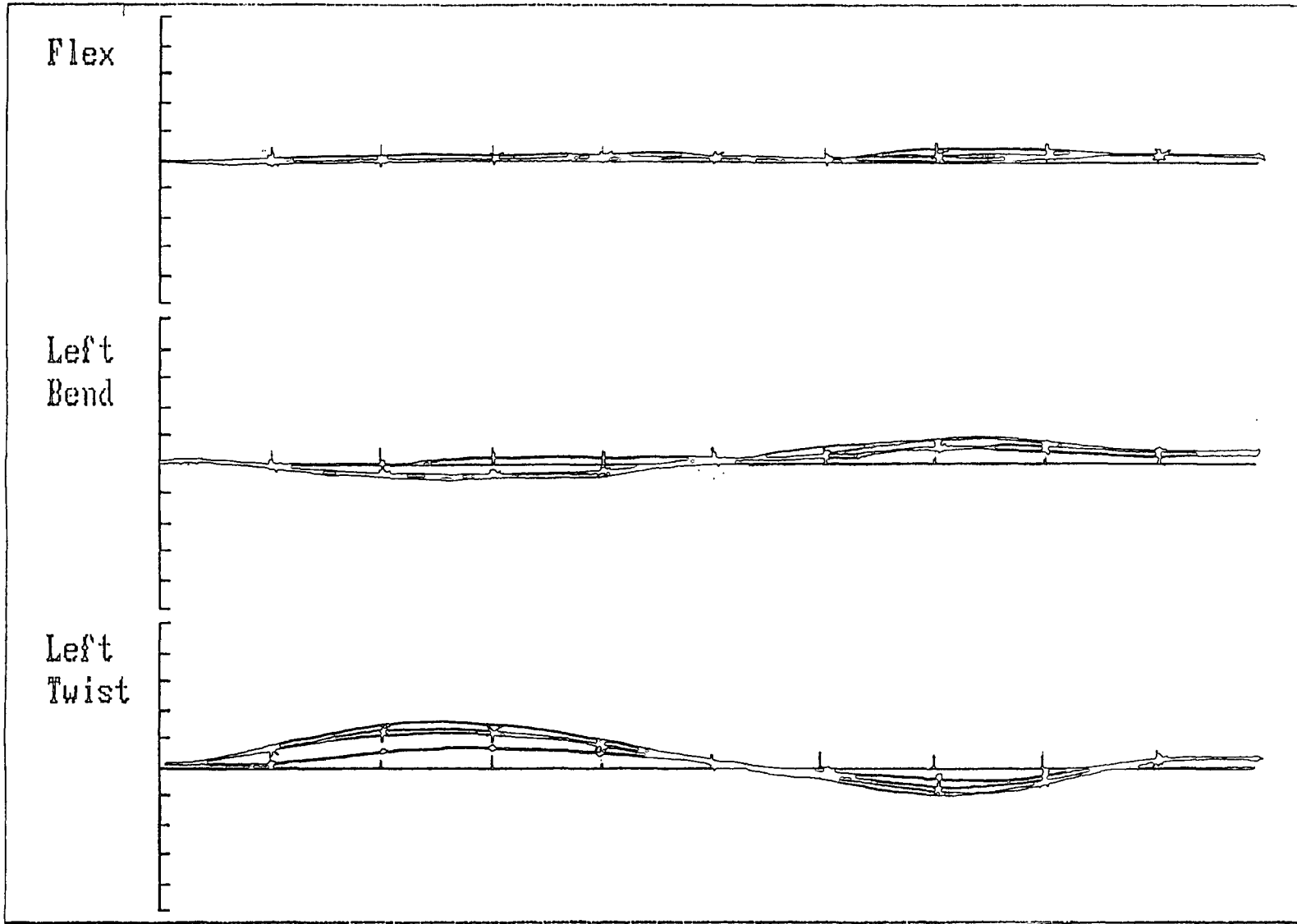

Figure 5.3 — Normal and North Tees Patient Groups Performing
 Axial Rotation

mal plots. The facet arthropathy group showed significantly restricted flexion and extension ($p < 0.005$). Lateral bend and the associated axial rotation were both significantly restricted ($p < 0.05$), coupled flexion was also restricted but this difference was not significant. Axial rotation and its coupled movements were normal. The disc group showed normal flexion but significantly restricted extension ($p < 0.025$). Lateral bend was significantly restricted ($p < 0.05$), coupled movements were restricted but at a non-significant level. Axial rotation was not significantly restricted but the coupled lateral bend occurring on left twist was significantly reduced ($p < 0.05$). The spondylolisthesis group showed significantly restricted flexion and extension ($p < 0.005$). Lateral bend was also significantly restricted as was the coupled axial rotation occurring on left bend ($p < 0.05$). Axial rotation was significantly restricted ($p < 0.025$), coupled movements were normal.

The significant differences between the pathological groups occurred primarily in flexion/extension, with the disc group showing significantly greater flexion than both of the other two groups ($p < 0.025$), between whom there were no differences. The other significant difference occurred in axial rotation where the facet group displayed more coupled lateral bend than the disc group ($p < 0.05$). However, several non-significant trends were displayed. The disc group did show greater lateral bend and axial rotation than the spondylolisthesis group. The facet group also displayed greater axial rotation than the spondylolisthesis group.

The ability of the 3SPACE Isotrak to detect abnormality of movement on the side of pain is assessed in Table 5.3, it is reasonable to assume that the side of pain represents the side of injury, since the clinician did not specify this on the assessment form.

Patient	Side of Pain (R,L or B)	Lateral Bend		Axial Rotation	
		Left	Right	Left	Right
MK	R	R	R		VR
CS	R	VR	VR	VR	VR
JU	R				
DO	L	R	R	H	
MP	B	R	N	VR	VR
BO	R	H	VR		
JM	B	R	VR	R	R
SM	R	R	R		
NM	R	R	R	VR	VR
JH	B				
EJ	L			H	H
GG	B		VR		
AB	R	VR	VR	R	VR
VA	R	R	R	R	R

Table 5.3 — Side of Pain and Abnormality of Movement in North Tees Patients

The Table shows any abnormality in a patients lateral bend or axial rotation indicating if a movement is restricted (R), very restricted (VR) or hyper-mobile (H), as defined earlier. A blank space indicates a normal movement.

The impression one gets from this Table is a poor correlation between the side of pain and any abnormalities in lateral bend and axial rotation to that side, as detected by the 3SPACE Isotrak. Only six of the patients showed agreement

between side of pain and abnormality of movement. Patient MK, with right sided pain, demonstrated very restricted axial rotation to that side with left being normal. Patient DO, with left sided pain, showed hyper-mobility in left sided axial rotation with right normal. Patient MP who had bilateral pain was bilaterally very restricted in axial rotation. Patient BO, with right sided pain, showed very restricted right lateral bend whereas left was hyper-mobile. Patient JM who had bilateral pain showed bilateral restriction in axial rotation. Patient AB who had right sided pain had very restricted axial rotation to that side, left was restricted. The remainder of patients tended to show either bilateral restriction in movement or bilaterally normal movements, no patients only showed abnormality on the opposite side to that of pain.

It is now appropriate to consider the clinical assessment of the patients' movements and how these compare to the results of the 3SPACE Isotrak. The clinician's assessments are presented in Table 5.4. The movements are classified as normal (left clear), and in three stages of restriction, slightly restricted (+), restricted (++) and very restricted (+++). The clinician made these assessments purely on his own subjective observation of a subject moving, his usual clinical practice.

Patient	Flexion	Extension	Lateral Bend	Axial Rotation
MK	+	+	+	+
CS				
JU	+++	+		
DO				
MP				
BO				
JM		+++	+++	+++
SM				
NM	++			
JH	+			
EJ				
GG	++		++	
AB				
VA				

Table 5.4 — North Tees Patient Clinical Movement Assessment

These assessments were made at the extremes of motion whereas those made with the 3SPACE Isotrak refer to the whole of the kinematic movement pattern. However, a comparison of the two sets of results will give some indication of the clinician's ability to subjectively gauge a patient's movements. No distinction was made between left and right lateral bend and axial rotation in the clinician's assessment so in order that the two results could be compared a restriction in at least one of the two sides of movement, as shown in Table 5.3, was counted as a restriction in that movement overall. The movements to be compared are,

therefore, flexion, extension, lateral bend and axial rotation, a total of 56 movements for the 14 patients. The 3SPACE Isotrak revealed some restriction in the kinematic movement pattern in 37 of these, the clinician, on the other hand, only found restriction (+, ++ or +++) in 8 of these movements, or 22%. Making the comparison the other way round the clinician identified restriction in 13 movements, the 3SPACE Isotrak found restriction in 9 of these, or 69%. The clinician recorded normal mobility in 8 of the patients shown in Table 5.4, measurement with the 3SPACE Isotrak, however, showed all but one of these patients to have some degree of restriction in at least two of the four movements.

5.3.2 Sunderland General Patient Results

A total of 22 patients were measured over a period of several months. The clinician was unable to make a positive diagnosis for 2 of these patients and as the basic aim of this research was to relate movement to pathology their results are not considered. Since the form completed for each patient was more comprehensive than that completed for the North Tees patients the basic details of the remaining 20 patients are shown in Table 5.5, with the remaining information included separately in Appendix G.

The Table indicates the type of onset of the patients' symptoms; sudden (S) or gradual (G).

The movements of the patients were assessed in the same manner as the North Tees patients and the results are presented similarly in Appendix E. Again it was apparent that there were very significant abnormalities in these patients' movements.

Patient Name	Sex	Age (yrs)	Onset	History <or>1 yr
JT	F	60	G	>
GH	M	52	G	>
LT	F	40	S	<
IB	F	61	S	>
ST	F	46	G	>
CW	F	35	S	>
MY	F	57	G	>
SG	F	48	G	>
PC	F	35	G	>
DB	F	22	G	>
LF	F	34	S	>
RW	M	50	S	>
DN	M	32	S	>
AA	M	35	S	>
ET	F	41	G	>
ED	F	38	G	>
TL	M	45	S	>
LR	M	47	S	>
AB	M	36	G	>
PR	F	38	G	>

Table 5.5 — Sunderland Patient Details

The diagnosis made for each patient is shown in Table 5.6 which also indicates if this diagnosis has been confirmed at surgery. In those cases in which the diagnosis has not been confirmed patients were either waiting for surgery or were undergoing treatment regimes other than surgery.

These patients can be divided into two main pathological groups; those having been diagnosed as having a lateral recess or a disc disorder. Two patients shared both of these conditions and in order to keep the homogeneity of the two groups they were excluded, leaving 7 patients in each group. Three patients remained, two having spondylolistheses and one facet osteo arthritis. The lateral recess and disc groups were compared to the movements of the 80 normals and to each other using the TPLOTT.BAS program.

Figures 5.4, 5.5 and 5.6 show the movements of the two patient groups compared to normal in the same manner as the North Tees results. Similary Appendix F contains the individual plots of these movements.

Both groups showed significant differences from normal. The lateral recess group showed significantly restricted flexion and extension ($p < 0.005$). Lateral bend and coupled axial rotation were both significantly restricted ($p < 0.05$). Axial rotation was significantly restricted ($p < 0.05$), coupled movements were not significantly different to normal. The disc group also showed significantly restricted flexion and extension ($p < 0.005$). No significant differences were seen in lateral bend or its associated movements. Right axial rotation was significantly reduced ($p < 0.05$) but left was normal, coupled lateral bend was significantly restricted to the right ($p < 0.05$) but was again normal to the left. The two spondylolisthesis patients could obviously not be considered as a group but their movements

Patient	Diagnosis	Confirmed
JT	Left sided lateral recess L5-S1.	Y
GH	Bilateral facet osteo-arthritis L5-S1.	-
LT	Left sided disc L5-S1.	Y
IB	Lateral recess L5-S1.	-
ST	Right sided disc L5-S1.	-
CW	Bilateral lateral recess L4-5 and L5-S1.	Y
MY	Bilateral lateral recess L4-5.	Y
SG	Bilateral lateral recess L5-S1.	Y
PC	Right sided disc L5-S1.	Y
DB	Right sided disc L5-S1.	-
LF	Right sided disc and lateral recess L5-S1.	-
RW	Right sided lateral recess L5-S1.	-
DN	Spondylolisthesis L5-S1.	-
AA	Spondylolisthesis L5-S1.	-
ET	Right sided disc L5-S1.	-
ED	Right sided disc and lateral recess L4-5.	Y
TL	Left sided lateral recess L4-5.	-
LR	Left sided lateral recess L5-S1.	-
AB	Right sided disc L5-S1.	-
PR	Left sided disc L5-S1.	-

Table 5.6 — Sunderland Patient Diagnoses

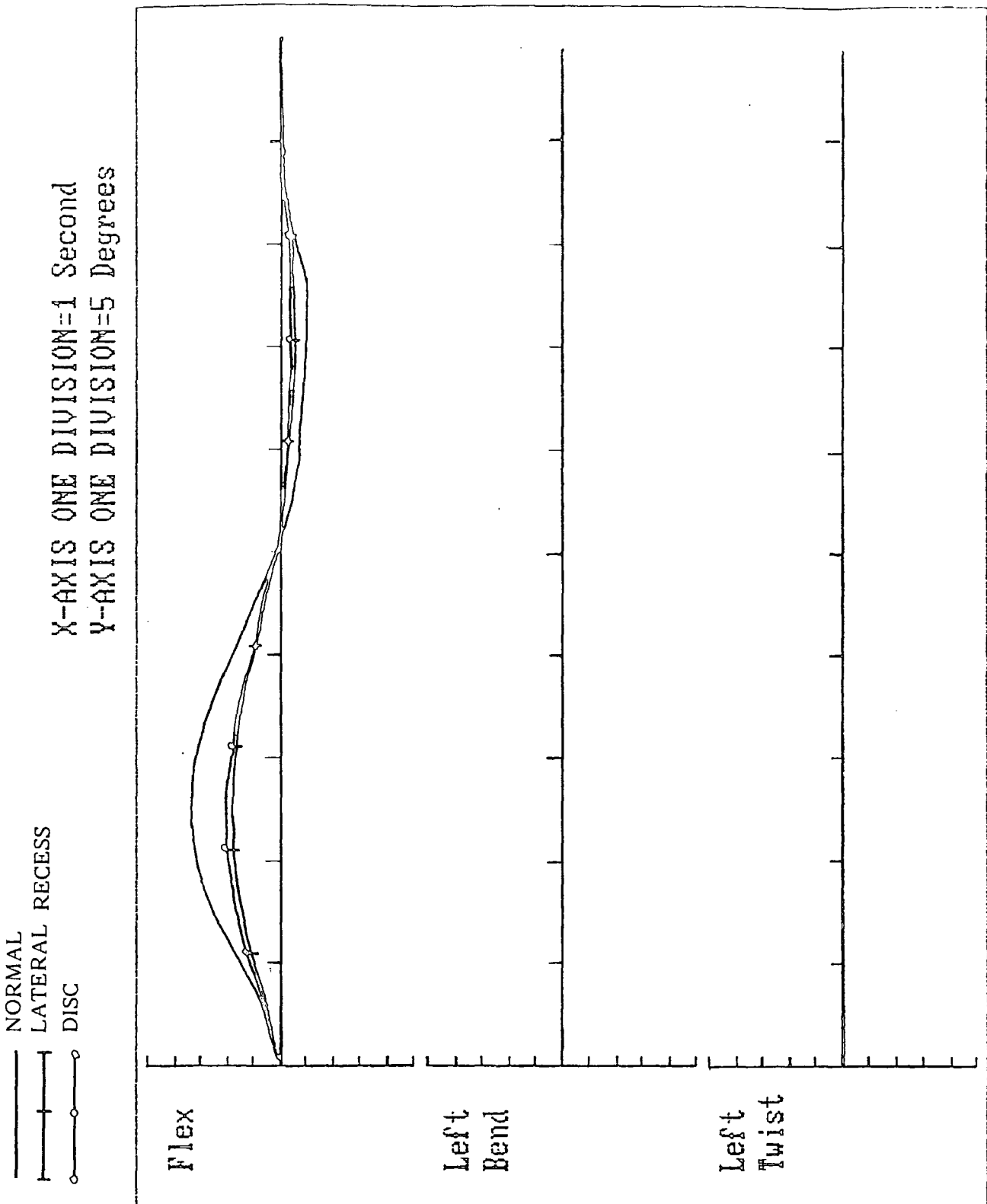

Figure 5.4 — Normal and Sunderland Patient Groups Performing Flexion and Extension

——— NORMAL
 —|— LATERAL RECESS
 —○— DISC
 X-AXIS ONE DIVISION=1 Second
 Y-AXIS ONE DIVISION=5 Degrees

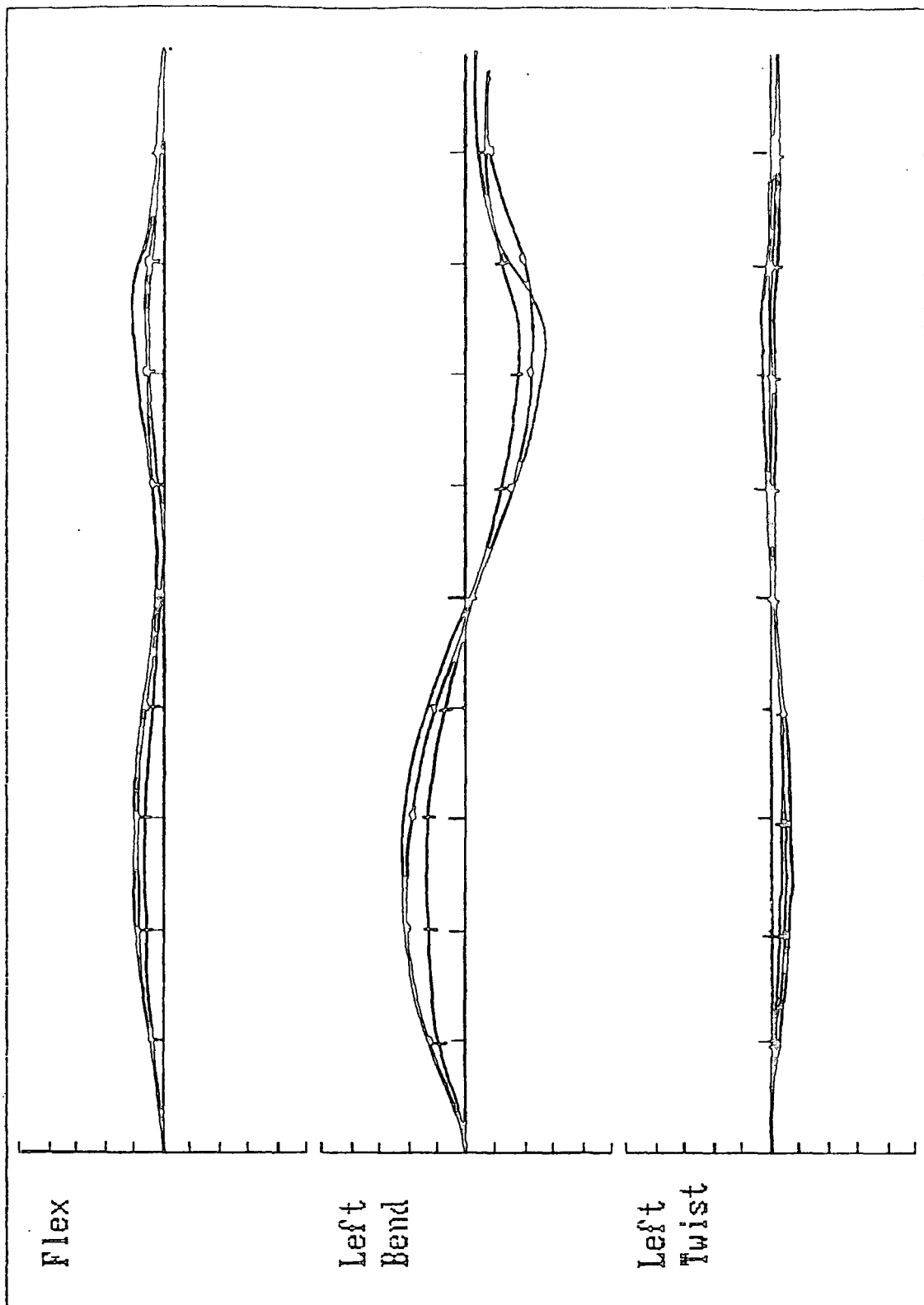

Figure 5.5 — Normal and Sunderland Patient Groups Performing Lateral Bend

can still be considered. Both demonstrated restricted flexion and extension, symmetrically restricted lateral bend and some degree of restriction in axial rotation. Interestingly both showed coupled lateral bend on axial rotation to the same side as the twist.

No significant differences between the kinematic movement patterns of the two groups were seen in flexion or extension. The disc group did show greater lateral bend and coupled flexion than the lateral recess group although these trends were non-significant. The disc group again showed greater axial rotation than the lateral recess group but this was also non-significant, however the disc group did show significantly more coupled bend on right axial rotation than the lateral recess group ($p < 0.05$).

The assessment form completed for each of the Sunderland patients specified the side of pathology as well as the side of pain. The ability of the 3SPACE Isotrak to detect abnormality in movement to the side of pathology and side of pain is assessed in Table 5.7.

The Table indicates the type of abnormality in movement in the same manner as Table 5.3, however some patients had no movement and this is recorded as 0. It will be noted that patient AA was suffering from no pain. It can also be seen that in the great majority of patients the side of pain, perhaps not surprisingly, was the same as the pathologic side.

Seven patients showed abnormality of movement towards the side of pain, or of pathology, or both. Patient GH with right sided pain and bilateral facet osteo-arthritis, showed very restricted right lateral bend whereas left was only restricted and also showed restriction in right sided axial rotation. Patient IB,

Patient	Side of	Side of	Lateral Bend		Axial Rotation	
	Pain		Pathology	Left	Right	Left
JT	L	L				
GH	R	B	R	VR		R
LT	L	L			0	0
IB	R	R	R	VR	0	0
ST	R	R	VR		R	R
CW	L	B	VR	VR	R	R
MY	B	B	VR	VR		
SG	L	B	R		R	
PC	R	R	H	R		
DB	R	R	N	N	VR	
LF	R	R	VR	R		
RW	L	R				
DN	L	B	R	R	R	R
AA	-	B	R	R	VR	0
ET	R	R	R	R	R	
ED	R	R	VR		R	N
TL	L	L	VR	VR	0	VR
LR	L	L			R	
AB	R	R				
PR	L	L	VR	R		

Table 5.7 — Side of Pain, Pathology and Restriction in Movement in
Sunderland Patients

with right sided pain and pathology, again showed greater restriction to that side during lateral bend. Patient SG, with left sided pain and bilateral L5-S1 lateral recess, showed restricted left lateral bend and axial rotation. Patient PC, with right sided pain and pathology, showed restricted lateral bend to this side, left being hyper-mobile. Patient TL, with left sided pain and pathology, showed very restricted axial rotation to that side, right being normal. Patient LR, with left sided pain and pathology, showed restricted axial rotation to that side. Finally, patient PR, with left sided pain and pathology, showed very restricted lateral bend to that side whereas right was only restricted.

The clinical assessment of patients' movements was again subjective, being based on the observation of the patient moving and the clinician's experience. The clinician's usual practice was to classify movements as percentages of normal, these are shown in Table 5.8. The solid line indicates where no assessment of movement was made or where the information was missing from the patient's records.

It can be seen from the Table that the clinician identified some restriction in the movements of the majority of the patients. Of those movements that the clinician had identified some restriction in (ie less than 100% movement) the 3SPACE Isotrak identified some degree of restriction (R or VR) in 64% of these. Conversely of the movements that the 3SPACE Isotrak identified some restriction in the clinician showed a 73% agreement. The 3SPACE Isotrak found zero movement in 7 of the patients various movements, the clinician found no movement in 3 of these cases.

Patient	Flexion	Extension	Lateral Bend		Axial Rotation	
			Right	Left	Right	Left
JT	50	0	0	60	50	50
GH	100	30			60	60
LT	-	-	-	-	-	-
IB	40	0	50	50	30	30
ST	100	100	100	100	100	100
CW	30	0	30	30	30	30
MY	50	10	50	50	30	30
SG	50	10	50	50	50	50
PC	80	100	100	100	-	-
DB	100	30	50	100	50	100
LF	50	0	30	100	30	50
RW	30	0	20	20	-	-
DN	100	100	100	100	100	100
AA	50	30	50	50	-	-
ET	50	0	0	50	-	-
ED	50	0	50	0	0	0
TL	50	30	30	30	30	30
LR	75	100	100	100	100	100
AB	20	0	80	100	50	50
PR	50	100	100	70	100	80

Table 5.8 — Sunderland Patient Clinical Movement Assessment

5.4 Discussion

The 3SPACE Isotrak proved easily adaptable to use in the clinical setting, being quick to set up and requiring relatively little space in which to operate. Furthermore, individual patient contact time was reasonably low, being no more than 10 minutes each, a dramatic reduction in comparison to any existing three-dimensional measurement system.

The comparison of each patient's movements to those of matched normal groups revealed widespread abnormality of primary and coupled movements, in fact every patient measured showed some abnormality in their movements. The great majority of patients showed some degree of restriction in their movements, with hyper-mobility being relatively uncommon. When put into groups on the basis of common pathology many differences from the movement plots of the 80 normal subjects were observed. Flexion and extension produced the most significant changes from normal, both movements being significantly restricted at the 99.5% level in all patient groups except the North Tees disc group which showed normal flexion and restricted extension at a lower confidence level (97.5%). Lateral bend was bilaterally restricted in all but the Sunderland disc group, which showed normal movement, at the 95% confidence level. No group showed significantly altered flexion coupled to the lateral bend but coupled axial rotation tended to show some degree of restriction. Axial rotation showed the most variation between the patient groups in respect to changes from normal. Both the facet and disc groups from the North Tees study showed no significant differences from normal but the disc group did show significantly coupled lateral bend to one side. The North Tess spondylolisthesis group showed significantly restricted axial rotation ($p < 0.025$) with normal coupled bend. Both Sunderland patient

groups showed significantly restricted axial rotation ($p < 0.05$) but whereas the lateral recess group demonstrated normal coupled lateral bend the disc group showed significant restriction in this to one side.

When compared to one another there were differences in the movements of the patient groups, however, few of these reached statistical significance. The only significant difference between the North Tees patient groups was the greater flexion displayed by the disc group as compared to the facet arthropathy and spondylolisthesis groups. The only significant difference to be seen between the two Sunderland patient groups was the greater coupled bend seen accompanying axial rotation, to one side, by the disc group.

These results suggest that the 3SPACE Isotrak is able to distinguish between the kinematic movement patterns of the normal and pathologic spine but is less able to distinguish between specific patient groups. A number of explanations present themselves as to why the movement patterns of the pathological groups were not more substantially different. When the North Tees patients were divided into groups it was noted that many had complex diagnoses, this meant, for example, that many of those included in the facet arthropathy group were also suffering from disorders of the intervertebral disc. It is perhaps not surprising, therefore, that no clear differences emerged between the groups. However, the groupings made of the Sunderland patients were much more homogeneous with no multiple diagnoses and yet there were still few significant differences between groups. It should be kept in mind that each clinician reaches his diagnosis in an individual manner and it is perhaps unwise to draw any conclusions from differences observed between the two patient groups. It may be that, in fact, different pathological conditions of the lumbar spine do not produce significantly

different alterations to the movements of the whole back, that can be identified at this gross level where the movements of the musculature and uninjured joints may mask any disruption being displayed at a specific intervertebral level. However, it can also be argued that, whatever the homogeneity of the groups and patterns shown, the numbers involved were far too small to reveal any differences that may exist between pathologies.

The 3SPACE Isotrak was only moderately good at identifying abnormality of movement on the side of pain or pathology. In less than half of all patients measured was there disruption in either lateral bend or axial rotation to the side of pain, or pathology. Assuming that the 3SPACE Isotrak is providing an accurate description of a patient's movements this result would tend to suggest that injury to one side of a lumbar intervertebral joint has no consistent effect upon the movement of the low back as a whole.

This work was able to determine the ability of the two clinicians to correctly classify a patient's movement. As was discussed in Chapter 1 most clinicians will only perform a subjective assessment of a patient's movements, relying on their experience to classify abnormality. The two clinicians showed differing agreement between their observations and the results of the 3SPACE Isotrak showing 22% and 73% agreement respectively. These figures were based upon identifying any restriction in a patient's movements and so tend to exaggerate agreement between the two techniques. Even when the 3SPACE Isotrak identified severe restriction in a patient's movements the clinicians often recorded normal or only marginally restricted movements. The assessment of the complex three-dimensional movements of the low back by eye should, therefore, be considered to be of limited use.

The small numbers of patients measured in this study means it is impossible to conclusively rule out the possibility that pathologies may reveal themselves in differences to kinematic movement patterns as measured by the 3SPACE Isotrak. Future work in this area should, therefore, concentrate on the measurement of large numbers of homogeneous patients. If this work still revealed no relation between pathology movement of the low back then one must consider a return to invasive techniques that would allow the kinematic analysis of the movements of actual intervertebral motion segments as it seems that these alterations are being masked by the gross movement of the whole lumbar spine. Breen *et al* (1988) have recently described preliminary studies using a two-dimensional image intensifier technique which could be developed to provide three-dimensional radiographic analysis of intervertebral kinematics. It would prove useful to compare the movement patterns of a subject measured by such a method and by the 3SPACE Isotrak.

Further work should also address the use of the 3SPACE Isotrak in the assessment of various treatment regimes upon a patient's movements. It was shown earlier in this thesis that normal individuals are able to perform movements with reproducible patterns. Alterations to a patient's characteristic plots could be regularly assessed and form an integral part of a the clinical assessment.

5.5 Conclusions

The conclusions of this study are thus:

1. The 3SPACE Isotrak is a clinically effective method for the non-invasive, three-dimensional kinematic measurement of lumbar spinal mobility.

2. The 3SPACE Isotrak revealed widespread disruption to the primary and coupled movements of various low back pain patients when compared to those of normal subjects but was unable to distinguish clearly between the movements of discrete patient groups.
3. The normal subjective assessment of lumbar movement employed in the clinic should be considered to bear poor correlation to the actual movements of the spine.

Chapter VI

Concluding Remarks

This thesis has described a new non-invasive method for the three dimensional kinematic analysis of lumbar spinal motion, the 3SPACE Isotrak. This has shown itself to be accurate, reliable and easy to use. A pool of normative data has been collected providing the most comprehensive information to date on the kinematics of the normal back. Preliminary trials showed the 3SPACE Isotrak to be a satisfactory clinical measurement device, satisfying the criteria of ease and speed of use with no detrimental effects upon the patient. It was readily able to distinguish between the kinematic movements of normal and pathologic groups and it may be able to delineate specific patient groups. Future work should, therefore, concentrate on the measurement of large numbers of homogeneous patient groups.

Subsidiary to this, the main theme of the thesis, a number of other issues in this field have been investigated. Increased axial rotation was shown to be available in flexed postures both *in vivo* and, *in vitro*, in isolated lumbar motion segments. This suggested that a combination of these movements may be a factor in the initiation of damage to the intervertebral disc. It was noted that high degrees of flexion tended to reduce the available axial rotation, in comparison to less flexed postures. It was suggested that this may have been a result of the tightening of the posterior ligaments. The mechanical function of these ligaments were determined *in vitro* and the results showed them to be active only towards the end of flexion thus confirming the earlier hypothesis.

Much of the work in this thesis has already been accepted for publication and these papers are include in Appendix H.

Bibliography

1. Adams M.A. and Hutton W.C. (1981) *The relevance of torsion to the mechanical derangement of the lumbar spine*. Spine 6:241-8.
2. Adams M.A. and Hutton W.C. (1982) *Prolapsed intervertebral disc. A hyperflexion injury ?* Spine 7:184-191.
3. Adams M.A., Dolan P., Marx C. and Hutton W.C. (1986) *An electronic inclinometer technique for measuring lumbar curvature*. Clin Biomech. 1:130-4.
4. Ahlback S.O. and Lindahl O. (1964) Acta Orthop Scand. 34:310.
5. Aho A., Vartianinen O. and Salo O. (1955) *Segmental mobility of the lumbar spine in anterior-posterior flexion*. Ann Med Int Fena. 44:275-285.
6. Allbrook D. (1957) *Movements of the lumbar spinal column*. J Bone Jt Surg. 39:335-339.
7. An K.N., Jacobsen M.C., Berghund L.J. and Chao E.Y.S. (1988) *Application of a magnetic tracking device to kinesiological study*. J Biomech. 21:613-620.
8. Anderson J.A.D. (1976) *Back pain in industry*. in Jayson M.I.V., ed. The Lumbar Spine and Back Pain. London, Pitman.
9. Anderson J.A.D. and Sweetman B.J. (1975) *A combined flexi-rule and hydrogoniometer for measurement of the lumbar spine and its movement*. Rheumatol and Rehab. 14:173-9.

10. Arkin A. (1950) *The mechanism of rotation in combination with lateral deviation in the normal spine.* J Bone Jt Surg. 32(A):180-8.
11. Asmussen E., Heeboll-Nielsen K. (1959) Acta Orthop Scand. 28:174.
12. Auchincloss S. (1983) *The painful back, practical aspects of management.* Medicine Publishing Foundation, Oxford.
13. Bartelink D.L. (1957) *The role of abdominal pressure in relieving the pressure of the lumbar intervertebral discs.* J Bone Jt Surg. 39(B):18-25.
14. Batti'e M., Bigos S., Sheely A. and Wortley M. (1987) *Spinal flexibility and factors that influence it.* Phys Ther. 67:653-8.
15. Begg A.C. and Falconer M.A. (1949) *Plain radiology in intraspinal protrusion of lumbar intervertebral discs.* Br J Surg. 36:225-239.
16. Benati M., Goglio S., Morasoo P., Tagliaser V. and Zaccarin R. (1980) *Anthropometric robotics 1. Representing mechanical complexity.* Biol Cybernet 38:125-140.
17. Bennett P.H. and Birch T.A. (1967) *New York symposium on population studies in the rheumatic diseases. New diagnostic criteria.* Bull Rheum Dis. 17:453.
18. Benson D.R., Schultz A.B. and Dewald R.L. (1976) *Roentgenographic evaluation of vertebral rotation.* J Bone Jt Surg. 58:1125-1129.
19. Bogduk N. and Macintosh J.E. (1984) *The applied anatomy of the thoracolumbar fascia.* Spine 9:164-170.
20. Bogduk N., Macintosh J.E. and Percy M.J. (In Press, Spine) *Universal*

model of the lumbar back muscles.

21. Bogduk N. and Twomey L.T. (1987) *Clinical anatomy of the lumbar spine.* Churchill Livingstone.
22. Breen A., Allen R. and Morris A. (1988) *An image processing method for spine kinematics - preliminary studies.* Clin Biomech. 3:5-10.
23. Buchalter D., Parianpour M., Nordin M. and Kahnovitz N. (1986) *A non-invasive in-vivo technique for examining posture and functional spinal motion.* In Trends in Ergonomics and Human Factors III. Elsevier Science Publications. pp 727-737.
24. Buchalter D., Parianpour M., Viola K., Nordin M. and Kahnovitz N. (1989a) *Three-dimensional spinal motion measurements. Part 1: A technique for examining posture and functional spinal motion.* J Spinal Dis. 1:279-283.
25. Buchalter D., Kahnovitz N., Viola K., Dorsky S. and Nordin M. (1989b) *Three-dimensional spinal motion measurements. Part 2: A noninvasive assessment of lumbar brace immobilisation of the spine.* J Spinal Dis. 1:284-6.
26. Burton A.K. (1987) *Patterns of lumbar sagittal mobility and their predictive value in the natural history of back and sciatic pain.* Thesis, Huddersfield Polytechnic.
27. Burton A.K. (1986) *Regional lumbar sagittal mobility; measurement by flexicurves.* Clin Biomech. 1:20-26.
28. Chazal J., Tanguy A., Bourges G., Gaurel G., Escande G., Guillot M. and Vanneuville G. (1985) *Biomechanical properties of spinal ligaments and a*

histological study of the supraspinal ligament in traction. J Biomech. 18:167-176.

29. Dimnet J., Fischer L.P., Gonon G. and Garret J.P. (1978) *Radiographic studies of lateral flexion in the lumbar spine.* 11:143-50.
30. Drerup B. (1985) *Improvements in measuring vertebral rotation from the projections of the pedicles.* J Biomech 18:369-378.
31. Dunham W.F. (1949) *Measurement of hip and spine movements.* Br Jr Phys Med. Sept-Oct:126-129.
32. Elnaggar M., Nordin M., Sheikhzadel A. and Kahnovitz N. (1988) *Correlation between low back pain severity and spinal mobility in chronic low back pain patients treated with spinal exercises.* Presented at the International Society for the study of the Lumbar Spine. Miami, Florida, April 13-17.
33. Elnaggar M., Nordin M., Sheikhzadel A. and Kahnovitz N. (1988) *The effects of spinal flexion and extension exercises on low back pain and spinal mobility in chronic mechanical low back pain patients.* Presented at the International Society for the study of the Lumbar Spine. Miami, Florida, April 13-17.
34. Farfan H.F. (1973) *Mechanical disorders of the low back.* Lea and Febiger.
35. Fitzgerald G.K., Wynveen K.J., Rheault W. and Rothchild B. (1983) *Objective assessment with establishment of normal values for lumbar spinal range of motion.* Phys Ther. 63:1776-1781.
36. Frymoyer J.N., Hanley E.N., House J., Kuhlman D.M. and Matteri R.E. (1979) *A comparison of radiographic findings in fusion and non-fusion pa-*

tients ten or more years following lumbar disc surgery. Spine 4:435-440.

37. Frymoyer J.W., Frymoyer W.W., Wilder D.G. and Pope M.H. (1979) *The mechanical and kinematic analysis of the lumbar spine in normal living human subjects in vivo.* J Biomech. 12:165-172.
38. Gertzbein S.D., Seligman J., Holtby R., (1985) *Centrode patterns and segmental instability in degenerative disc disease.* Spine 10:257-261.
39. Gertzbein S.D., Seligman J., Holtby R., (1986) *Centrode characteristics of the lumbar spine as a function of segmental instability.* Clin Orthop. 208:48-51.
40. Gianturco G. (1944) *A roentgen analysis of the motion of the lower lumbar vertebrae in normals and in patients with low back pain.*
41. Gonnella C., Paris S. and Kutner M. (1982) *Reliability in evaluating passive intervertebral motion.* Phys Ther. 62:436-444.
42. Gracovetsky S., Farfan H.F. and Helleur C. (1985) *The abdominal mechanism.* Spine 6:317-324.
43. Gracovetsky S. (1986a) *Function of the spine.* J Biomed Eng 8:217-223.
44. Gracovetsky S., Farfan H.F. and Lamy C. (1986b) *The mechanism of the lumbar spine.* Spine 6:249-262.
45. Gracovetsky S. (1989) *Potential of lumbodorsal fascia forces to generate back extension moments during squatlifts.* Letter to the Editor. J Biomed Eng 11:172-3.
46. Gregerson G.C. and Lucas D.B. (1967) *An in vivo study of the axial rotation of the human thoracolumbar spine.* J Bone Jt Surg. 49(A):247-262.

47. Grew N.D. and Harris J.D. (1979) *A method of measuring human body shape and movement - the vector stereograph*. Eng in Med. 8:115-119.
48. Griffin A.B., Troup J.D.G. and Lloyd D.C.E.F. (1984) *Tests of lifting and handling capacity. Their repeatability and relationship to back symptoms*. Ergonomics 27:305-20.
49. Haley S.M., Tada W.L. and Carmichael E.M. (1986) *Spinal mobility in young children*. Phys Ther. 66:1687-1703.
50. Hanley E.N., Matteri R.E. and Frymoyer J.W. (1976) *Accurate roentgenographic determination of lumbar flexion and extension*. Clin Orth Rel Res. 115:145-8.
51. Hart D.L. and Rose S.J. (1986) *Reliability of a non-invasive method for measuring the lumbar spinal curve*. J Orthop Sports Phys Ther. 8:180-4.
52. Hasberry S. and Pearcy M.J. (1986) *Temperature dependence of the tensile properties of interspinous ligaments of sheep*. J Biomed Eng 8:62-66.
53. Hayes M.A., Howard T.C., Gruel C.R. and Kopta J.A. (1989) *Roentgenographic evaluation of lumbar spine flexion extension in asymptomatic individuals*. Spine 14:327-331.
54. Heylings D.J.A. (1978) *Supraspinous and interspinous ligaments of the human lumbar spine*. Jr Anat. 125:127-131.
55. Hill-Smith M. (1987) *Final year project report*. University of Durham.
56. Hilton R.C., Ball J. and Benn R.T. (1979) *In-Vitro mobility of the lumbar spine*. Ann Rheum Dis. 38:378-383.

57. Israel M. (1959) *A quantitative method of estimating flexion and extension of the spine - a preliminary report.* Military Med. March:181-6.
58. Janssen R. (1989) *Final year project report.* University of Durham.
59. Jirout J. (1957) *The normal mobility of the lumbar spine.* Acta Radiol. 47:345-8.
60. Johnson R.J. (1987) *The mechanical testing of the interspinous ligaments of sheep.* Project Report, University of Durham.
61. Kaltenborn F. and Lindahl O. (1984) *Reproducibility of the results of manual mobility testing of specific intervertebral segments.* Swedish Medical J. 66:962-5.
62. Kelly S. (1985) *Measurement of the lumbar spine-the evaluation of back care education.* MSc Thesis, Loughborough University of Technology.
63. Klausen K., Nielsen B. and Madsen L. (1981) *Form and function of the spine in young males with and without back troubles.* In Morecki A., ed, Biomechanics VII pp174-80.
64. Lindahl O. (1966) *Determination of the sagittal mobility of the lumbar spine.* Acta Orthop Scand. 37:241-254.
65. Liu Y.K., Goel V.K., Dejong A., Njus G., Nishiyama K. and Buckwalter J. (1985) *Torsional fatigue of the lumbar intervertebral joints.* Spine 10:894-910.
66. Loebel W.Y. (1967) *Measurement of spinal posture and spinal range of movement.* Ann Phys Med. 9:103-110.
67. Loebel W.Y. (1973) *Regional rotation of the spine.* Rheumatol and Rehab.

12:223.

68. Lumsden R.H. and Morris J.M. (1968) *An in-vivo study of axial rotation and immobilization at the lumbrosacral joint.* J Bone Jt Surg. 50(A):1591-1601.
69. MacGibbon B. and Farfan H.F. (1979) *A radiologic survey of various configurations of the lumbar spine.* Spine 4:258-266.
70. Macintosh J.E., Bogduk N. and Gracovetsky S. (1987) *The biomechanics of the thoracolumbar fascia.* Clin Biomech. 2:78-83.
71. Macrae I.F. and Wright V. (1969) *Measurement of back movement.* Ann Rheum Dis. 28:584-589.
72. Markolf K.L. (1972) *Deformation of the thoracolumbar intervertebral joint in response to external loads: a biomechanical analysis using autopsy material.* J Bone Jt Surg. 54(A):511.
73. Marras W.S. and Wongsam P.E. (1986) *Flexibility and velocity of the normal and impaired lumbar spine.* Arch Phys Med Rehabil. 67:213-7.
74. Mayer T., Tencer A.F., Kristoferson S. and Mooney V. (1984) *Use of non-invasive techniques for quantification of spinal range-of-motion in normal and chronic back dysfunction patients.* Spine 9:588-595.
75. McConnel D.G. et al (1980) *Low agreement of findings in neuromuscular examination by a group of osteopathic physicians using their own procedures.* J Am Osteopath Assoc. 79:441-50.
- 76 McGill S.M. and Norman R.W. (1986) *Partitioning of the L4-L5 dynamic movement into disc, ligamentous and muscular components during lifting.*

Spine 11:666-678.

77. McGill S.M. and Norman R.W. (1988) *Potential of lumbodorsal fascia forces to generate back extension moments during lifting.* J Biomed Eng. 10:312-8.
78. McGill S.M. and Norman R.W. (1989) *Potential of lumbodorsal fascia forces to generate back extension moments during squat lifts.* Letter to the Editor. J Biomed Eng. 11:173-5.
79. Mellin G.P. (1986) *Measurement of thoracolumbar posture and mobility with a Myrin inclinometer.* Spine 11:759-762.
80. Mellin G.P. (1989) *Comparison between tape measurement of forward and lateral flexion of the spine.* Clin Biomech. 4:121-3.
81. Mensor M.C. and Duvall G. (1959) *Absence of motion at the fourth and fifth lumbar interspaces in patients with and without low-back pain.* J Bone Jt Surg. 41(A):1047.
82. Miles M. and Sullivan W.E. (1961) *Lateral bending at the lumbar and lumbosacral joints.* Anatom Rec. 3:387-392.
83. Mitchelson D.L. (1973) *An opto-electronic technique for analysis of angular movements.* Med and Sport. 8:181-4.
84. Moll J.M.H., Liyanage S.P. and Wright V. (1972a) *An objective clinical method to measure lateral spinal flexion.* Rheum Phys Med. 11:225-239.
85. Moll J.M.H., Liyanage S.P. and Wright V. (1972b) *An objective clinical method to measure spinal extension.* Rheum Phys Med. 11:293-312.
86. Moll J.M.H. and Wright V. (1971) *Normal range of spinal mobility.* Ann

Rheum Dis. 30:381.

87. Moll J.M.H. and Wright V. (1987) *Measurement of spinal movement*. in *The Lumbar Spine and Back Pain*. ed Jayson M. Churchill Livingstone.
88. Nash C.L. and Moe J.H. (1969) *A study of vertebral rotation*. *J Jt Surg.* 51(A):223-229.
89. Nissan M. and Gilad I. (1984) *The cervical and lumbar vertebrae- an anthropometric model*. *Eng in Med.* 13:111-4.
90. Ogston N.C., King G.J., Gertzbein S.D., Tile M., Kapasouri A. and Rubenstein J.D. (1984) *Centrode patterns in the lumbar spine*. *Spine* 9:591-5.
91. Ogston N.G., King G.J., Gertzbein S.D., Tile M., Kapasouri A. and Rubenstein J.D. (1986) *Centrode patterns in the lumbar spine - baseline studies in normal subjects*. *Spine* 11:591-5.
92. Olsson T.H., Selvik G. and Willner S. (1977) *Mobility in the lumbrosacral spine after fusion studied with the aid of roentgen stereophotogrammetry*. *Clin Ortho Rel Res.* 129:181-190.
93. Panjabi M.M., Hausfeld J.N. and White A.A. (1981) *A biomechanical study of the ligamentous stability of the thoracolumbar spine in man*. *Acta Orthop Scand.* 52:315-326.
94. Panjabi M.M., White A.A. and Johnson R.M. (1975) *Cervical spine mechanics as a function of transaction of components*. *J Biomech.* 8:327-336.
95. Panjabi M.M., Krag M.H. and Chung T.Q. (1984) *Effects of disc injury on mechanical behaviour of the human spine*. *Spine* 9:707-713.

96. Panjabi M.M., Krag M.H., White A.A. and Southwick W.O. (1977) *Effects of preload on load displacement curves of the lumbar spine*. Orthop Clin N Am. 8:181-192.
97. Pearcy M.J. (1985) *Stereo radiography of lumbar spine motion*. Acat Orthop Scand. Supp No 212, vol 56.
98. Pearcy M.J. (1986) *Measurement of back and spinal mobility*. Clin Biomech. 1:44-51.
99. Pearcy M.J. and Bogduk N. (1988) *Instantaneous axes of rotation of the lumbar intervertebral joints*. Spine 13:1033-1041.
100. Pearcy M.J., Gill J.M., Johnson G.R. and Hindle R.J. (1987a) *Patterns of movement in the normal human lumbar spine*. Manipulative Therapists Association of Australia 5th Biennial Conference Proceedings. pp 37-44.
101. Pearcy M.J., Gill J.M., Whittle M.W. and Johnson G.R. (1987b) *Dynamic back movement measured using a three dimensional television system*. J Biomech. 20:943-949.
102. Pearcy M.J., Gill J.M., Hindle R.J. and Johnson G.R. (1987c) *Measurement of human back movements in three dimensions by opto-electronic devices*. Clin Biomech. 2:199-204
103. Pearcy M.J., Portek I. and Shepard J. (1985) *The effect of low-back pain on lumbar movements measured by three-dimensional x-ray analysis*. Spine 10:150-3.
104. Pearcy M.J. and Tibrewal S.B. (1984) *Lumbar intervertebral disc and liga-*

- ment deformations measured in vivo.* Clin Orthop Rel Res 119:281-6.
105. Pennal G., Conn G., McDonald G., Dale G. and Garside H. (1972) *Motion studies of the lumbar spine.* J Bone Jt Surg. 54(B):442-452.
 106. Perianpour M., Buchalter D., Nordin M. and Kaknovitz N. (1986) *A non-invasive in-vivo measurement technique for the assessment of the 6 degrees of freedom of trunk motion.* In Advances in Bioengineering. Eds Latz S.A. and King A.L. pp 28-29.
 107. Plamondon A., Gagnon M. and Maurais G. (1988) *Application of a stereoradiographic method for the study of intervertebral motion.* Spine 13:1027.
 108. Portek I., Pearcy M.J., Reader G.P. and Mowat A.G. (1983) *Correlation between radiographic and clinical measurement of lumbar spine movement.* Br J Rheum. 22:197-205.
 109. Prestar F.J. (1982) *Morphology and function of the interspinous and supra-spinous ligaments of the lumbar spine.* Morphol Med. 2:53-8.
 110. Reynolds P.M.G. (1975) *Measurement of spinal mobility: A comparison of three methods.* Rheumatol and Rehab. 14:180.
 111. Rissanen P.M. (1960) *The surgical anatomy and pathology of supraspinous and interspinous ligament ruptures.* Acta Orthop Scand. (suppl) 46:35.
 112. Roland M. (1983) *Back pain...an unsolved problem.* Talkback 9:4.
 113. Salisbury P.J. and Porter R.W. (1987) *Measurement of lumbar sagittal mobility. A comparison of three methods.* Spine 12:1903.
 114. Schober P. (1937) *Lendenwirbelsaule und Krenzschemerzen.* Munch Med

Wschr 84:336-8.

115. Scholten P.J.M. and Veldhuizen A.G. (1985) *The influence of spine geometry on the coupling between lateral bending and axial rotation*. Eng Med. 14:167-171.
117. Schultz A.B., Warwick D.N., Berkson M.H. and Nachemson A.L. (1979) *Mechanical properties of human lumbar spine motion segments. Part 1: Responses in flexion, extension, lateral bending and torsion*. J Biomech Eng. 101:46-52.
117. Seligman J.V., Gertzbein S.D., Tile M. and Kapsouri A. (1986) *Computer analysis of the spinal motion segment in degenerative disc disease with and without axial loading*. Spine 9:566-573.
118. Shirazi-adl A., Ahmed A.M. and Shrivastava S.C. (1986) *Mechanical response of a lumbar motion segment in axial torque alone and combined with compression*. Spine 11:914-927.
119. Silver P.H.S. (1954) *Direct observations of changes in tension in the supraspinous and interspinous ligaments during flexion and extension of the vertebral column in man*. J Anat. 88:550.
120. Stokes I.A.F., Wilder D.G., Frymoyer J.W. and Pope M.H. (1981) *Assessment of patients with low-back pain by biplanar radiographic measurement of intervertebral motion*. Spine 6:233-240.
121. Stokes I.A.F. (1977) *Relationships between movements of vertebrae and adjacent skin markers and sections of the back*. Annual Report No. 4, Oxford Orthopaedic Engineering Centre, Oxford, U.K., pp41-3.

122. Stokes I.A.F., Bevins T.M. and Lunn R.A. (1987) *Back surface curvature and measurement of lumbar spinal motion*. Spine 12:355-61.
123. Tanz S. (1953) *Motion of the lumbar spine a roentgenographic study*. Am J Roent. 69:399-412.
124. Taylor J. and Twomey L. (1980) *Sagittal and horizontal plane movement of the human lumbar vertebral column in cadavers and in the living*. Rheumatol and Rehab. 19:223-232.
125. Thurston A.J. and Harris J.D. (1983) *Normal kinematics of the lumbar spine and pelvis*. Spine 8:199-205.
126. Troup J.D.G., Hood C.A. and Chapman A.E. (1968) *Measurement of the sagittal mobility of the lumbar spine and hips*. Ann Phys Med. 9:308-321.
127. Troup J.D.G., Martin J.W. and Lloyd D.C.E.F. (1981) *Backpain in industry, a prospective study*. Spine 6:61-9.
128. Twomey L. (1979) *The effects of age on the ranges of motions of the lumbar region*. Aust J Physio. 25:257-263.
129. Twomey l. and Taylor J.R. (1983) *Sagittal movements of the human lumbar vertebral column: A quantitative study of the role of the posterior vertebral elements*. Arch Phys Med Rehab. 64:322-325.
130. Weitz E.M. (1981) *The lateral bending spine*. 6:388-397.
131. Wells N. (1985) *Back pain*. Publication no. 78, London Office of Health Economics.
132. Whittle M.W. (1982) *Calibration and performance of a three-dimensional*

television system for kinematic analysis. J Biomech. 15:185-196.

133. Wickstrom G., Nummi J. and Nurminen M. (1978) *Restriction and pain during forward bending in concrete reinforcement workers.* Scand J Work Environ Health. suppl 1:29-38.
134. Wood P.H.N. (1980) *Understanding back pain.* In Jayson M., ed, *The Lumbar Spine and Back Pain.* London, Pitman, pp1-27.
135. Wright V. (1983) *The measurement of back movement.* Br J Rheumatol. 22:193-6.
136. Vanharanta H., Korpi J., Heliovaara M. and Troup J.D.G. (1985) *Radio-graphic measurements of lumbar spinal canal size and their relation to back mobility.* Spine 10:461-6.
137. Viidik A. (1973) *Functional properties of collagenous tissues.* Int Review Conn Tissue Res. 6:127-215.

Appendix A

Computer Programs used for Data Analysis

This appendix contains the following programs:

1. RPROG.BAS
2. NORPLT.BAS
3. MEANPLT.BAS
4. TPLOT.BAS

```

10 KEY OFF
20 REM *****
30 REM PROGRAM RPROG.BAS
40 REM TO READ IN MOVEMENT DATA AND PRODUCE
50 REM PLOTS
60 REM RJH APR 88
70 REM *****
80 DIM FLEX(100),BEND(100),TWIST(100)
90 PTS%=100
100 INPUT "INPUT THE FILENAME";NAM$
110 DNAME$="A:"+NAM$+".ANG"
120 OPEN DNAME$ FOR INPUT AS #2
130 INPUT#2,SNAME$
140 INPUT#2,SEX$,AGE%,HT,WT
150 INPUT#2,FREQ%,TIME%,POINTS%
160 FOR I%=1 TO PTS%
170 INPUT#2,FLEX(I%),BEND(I%),TWIST(I%),X,Y,Z
180 NEXT I%
190 REM *****
200 REM DATA ANALYSIS
210 REM *****
220 CLS
230 MAX=-100
240 MIN=100
250 COUNT%=1
260 FOR I%=1 TO PTS%
270 M=FLEX(I%)
280 IF M>MAX THEN A%=COUNT%
290 IF M>MAX THEN MAX=M
300 IF M<MIN THEN B%=COUNT%
310 IF M<MIN THEN MIN=M
320 COUNT%=COUNT%+1
330 NEXT I%
340 FOR I%=1 TO PTS%
350 N=BEND(I%)
360 IF N>MAXB THEN A%=COUNT%
370 IF N>MAXB THEN MAXB=N
380 IF N<MINB THEN B%=COUNT%
390 IF N<MINB THEN MINB=N
400 COUNT%=COUNT%+1
410 NEXT I%
420 FOR I%=1 TO PTS%
430 L=TWIST(I%)
440 IF L>MAXT THEN A%=COUNT%
450 IF L>MAXT THEN MAXT=L
460 IF L<MINT THEN B%=COUNT%
470 IF L<MINT THEN MINT=L
480 COUNT%=COUNT%+1
490 NEXT I%
500 COLOR 7,1
510 PRINT "*****"
520 PRINT " DATA IS;"SNAME$
530 PRINT "SEX;"SEX$
540 PRINT "AGE;"AGE%
550 PRINT "HEIGHT="HT;"M"
560 PRINT "WEIGHT="WT;"KG"
570 PRINT "*****"
580 PRINT "DATA COLLECTION FREQUENCY="FREQ%;"Hz FOR";TIME%;"Secs"
590 PRINT " ("POINTS%;"DATA POINTS)"

```

```

600 PRINT "*****"
610 PRINT
620 PRINT
630 PRINT "MAXIMUM FLEXION=";MAX;" MAXIMUM EXTENSION=";-MIN;"(Degrees)
640 PRINT "MAXIMUM LEFT BEND=";MAXB;"MAXIMUM RIGHT BEND=";-MINB
650 PRINT "MAXIMUM LEFT TWIST=";MAXT;"MAXIMUM RIGHT TWIST=";-MINT
660 PRINT
670 PRINT
680 PRINT "PRESS RETURN TO CONTINUE"
690 Q$=INKEY$
700 IF LEN(Q$)=0 THEN GOTO 690
710 IF ASC(Q$)<>13 THEN GOTO 690
720 REM *****
730 REM GRAPH DRAWING SECTION
740 REM *****
750 CLS
760 SCREEN 9
770 LOCATE 1,1
780 PRINT "DATA IS;"SNAME$
790 REM *****
800 REM SET UP OF AXIS
810 REM *****
820 LINE (40,20)-(40,120)
830 LINE (40,70)-(540,70)
840 T%=70
850 GOSUB 950
860 LINE (40,130)-(40,230)
870 LINE (40,180)-(540,180)
880 T%=180
890 GOSUB 950
900 LINE (40,240)-(40,340)
910 LINE (40,290)-(540,290)
920 T%=290
930 GOSUB 950
940 GOTO 1020
950 FOR K%=40 TO 540 STEP 50
960 LINE (K%,T%)-(K%,T%+5)
970 NEXT K%
980 FOR B%=(T%-50) TO (T%+50) STEP 10
990 LINE (40,B%)-(37,B%)
1000 NEXT B%
1010 RETURN
1020 REM *****
1030 REM FLEXION PLOT
1040 REM *****
1050 PSET (40,70)
1060 FOR I%=2 TO PTS%
1070 XCOORD=(I%)*5+40
1080 YCOORD=-FLEX(I%)+70
1090 LINE - (XCOORD,YCOORD),2
1100 NEXT I%
1110 REM *****
1120 REM BEND PLOT
1130 REM *****
1140 PSET (40,180)
1150 FOR I%=2 TO PTS%
1160 XCOORD=(I%)*5+40
1170 YCOORD=-BEND(I%)+180
1180 LINE - (XCOORD,YCOORD),2

```

```

1190 NEXT I%
1200 REM *****
1210 REM     TWIST PLOT
1220 REM *****
1230 PSET (40,290)
1240 FOR I%=2 TO PTS%
1250 XCOORD=I%*5+40
1260 YCOORD=-TWIST(I%)+290
1270 LINE - (XCOORD,YCOORD),2
1280 NEXT I%
1290 CLOSE &2
1300 REM *****
1310 REM     LABELLING OF PLOTS
1320 REM *****
1330 LOCATE 5,1
1340 PRINT"Flex"
1350 LOCATE 12,1
1360 PRINT "Left"
1370 LOCATE 13,1
1380 PRINT "Bend"
1390 LOCATE 20,1
1400 PRINT "Left"
1410 LOCATE 21,1
1420 PRINT "Twist"
1430 LOCATE 1,40
1440 PRINT"X-AXIS ONE DIVISION=1 Second"
1450 LOCATE 2,40
1460 PRINT "Y-AXIS ONE DIVISION=10 Degrees"
1470 LOCATE 23,1
1480 END

```

```

10 REM *****
20 REM  NORPLT.BAS
30 REM  PROGRAM TO READ IN MOVEMENT DATA AND PRODUCE
40 REM  PLOTS
50 REM  MJP DEC 88  INDEX% error line 1830 corrected JUL 89
60 REM *****
70 ON ERROR GOTO 900
80 KEY OFF
90 DIM ANG(1000,3),NORM(1001,3),NMEAN(500,3)
100 DIM SDEV(500,3)
105 DIM A%(3)
110 DEFDBL M,I
112 A%(1)=%HCD55:A%(2)=%H5D05:A%(3)=%H90CB
113 PRTSC%=VARPTR(A%(1))
120 SCREEN 0:WIDTH 80
130 FLAG%=0
140 COUNT%=0
142 MAG%=1
144 MFLAG%=0
146 MTEST%=1
150 CLS
160 COLOR 14,1
170 PRINT*****
180 PRINT"  NORPLT.BAS "
190 PRINT"  PROGRAM TO READ IN MOVEMENT DATA AND PRODUCE "
200 PRINT"  NORMALISED PLOTS "
210 PRINT"          MJP DEC 88  Mod JUL 89 "
220 PRINT*****
230 COLOR 15,0
240 PRINT:INPUT "Which disc drive is the data file on [A]";D$
250 IF D$<>"A" AND D$<>"B" AND D$<>"C" AND D$<>"D" AND D$<>" " THEN
GOTO 240
260 IF D$="" THEN D$="A"
265 CLS
270 LOCATE 1,1:PRINT " "
280 LOCATE 1,1:INPUT "INPUT THE FILENAME ";NAM$
285 LOCATE 2,1:PRINT NAM$
290 DNAME$=D$+" ":"+NAM$+".ANG"
300 OPEN DNAME$ FOR INPUT AS #2
310 INPUT#2,SNAME$
320 INPUT#2,SEX$,AGE%,HT,WT
330 INPUT#2,FREQ%,TIME%,POINTS%
340 FOR I%=1 TO POINTS%
350 INPUT#2,ANG(I%,1),ANG(I%,2),ANG(I%,3),X,Y,Z :REM 1-FLEX,2-
BEND,3-TWIST
360 NEXT I%
370 CLOSE #2
380 COUNT%=COUNT%+1
390 PTS%=POINTS%-1 :REM FIRST PT IS 0
400 IF FLAG%<>0 THEN GOTO 560
420 REM *****
430 REM DATA ANALYSIS
440 REM *****
450 REM *****
460 REM GRAPH DRAWING SECTION
470 REM *****
480 CLS
490 SCREEN 9
491 FLAG%=1

```

```

520 REM *** SET UP WINDOW ***
530 VIEW (30,47)-(620,348),,15
560 LOCATE 2,1:PRINT NAM$
561 LOCATE 1,1:PRINT"
570 LOCATE 1,1:PRINT "PLOT NORMALISED DATA ONLY ?"
580 N$=INPUT$(1):IF N$="Y" OR N$="y" THEN GOTO 650
590 REM *** PLOT DATA ***
592 GOSUB 980:REM *** AXES ***
594 GOSUB 1170:REM *** LABELS ***
600 GOSUB 1350:REM *** PLOT GRAPHS ***
610 LOCATE 1,1
620 LOCATE 1,1:PRINT "
630 LOCATE 1,1:PRINT" NORMALISE      Y/N?
640 N$=INPUT$(1)
650 IF N$="Y" OR N$="y" THEN GOSUB 1500
660 LOCATE 1,1:PRINT "
670 LOCATE 1,1
680 PRINT" ANOTHER FILE Y/N?
685 LOCATE 2,1:PRINT NAM$
700 N$=INPUT$(1):IF N$<>"Y" AND N$<>"y" THEN GOTO 770
710 FLAG%=1
720 LOCATE 1,1:PRINT "
730 LOCATE 1,1:PRINT "DO YOU WISH TO OVERLAY IF SAME MOVEMENT Y/N ?"
740 N$=INPUT$(1):IF N$="Y" OR N$="y" THEN GOTO 760
750 CLS:FLAG%=2
760 GOTO 270
770 LOCATE 1,1:PRINT "
780 LOCATE 1,1:PRINT "Do you wish to plot (and save?) MEAN DATA Y/N
?"
790 N$=INPUT$(1):IF N$<>"Y" AND N$<>"y" THEN GOTO 810
800 GOSUB 2430
810 LOCATE 1,1:PRINT "OPTIONS:- 1 = plot THIS GRAPH and RERUN, 2 =
plot THIS GRAPH and return to MENU"
812 LOCATE 2,1:PRINT "3 = RERUN, 4 = return to MENU"
813 N$=INPUT$(1)
814 IF N$="3" THEN GOTO 878
815 IF N$="4" THEN GOTO 880
816 IF N$<>"1" AND N$<>"2" THEN GOTO 810
821 LOCATE 1,1:PRINT"
822 LOCATE 1,1:PRINT "FILE NAME :- ";NAM$
823 LOCATE 2,1:PRINT "
824 CALL PRTSC%
825 IF N$="1" THEN GOTO 878
830 IF N$="2" THEN GOTO 880
878 CLEAR:GOTO 10
880 CLEAR:CHAIN"C:\ISOTRAK\MENU"
890 END
900 REM *** FILE OPEN ERROR ROUTINE ***
910 IF (ERR = 53 ) THEN GOTO 920 ELSE IF (ERR = 71) THEN GOTO 920
ELSE END
920 LOCATE 1,1:PRINT " FILE NOT FOUND - CHECK THE DISC "
930 LOCATE 2,1
940 INPUT "PRESS ANY KEY TO CONTINUE",ANS$
950 LOCATE 1,1:PRINT "
960 LOCATE 2,1:PRINT "
970 RESUME 310
980 REM *****
990 REM *** SET UP 3 WINDOWS AND DRAW THE AXES ***
1000 REM *****

```

```

1010 FOR I%=1 TO 3
1020 VIEW (100,50+(I%-1)*95+(I%-1)*5)-(600,50+I%*95+(I%-1)*5)
1030 WINDOW (0,-100/MAG%)-(PTS%,100/MAG%)
1040 REM DRAW AXES
1050 LINE (0,0)-(PTS%,0):LINE(0,-100)-(0,100):REM X AND Y AXES
1060 REM DRAW TICKS ON X AXIS
1070 FOR J% = PTS%/10 TO PTS% STEP PTS%/10
1080 LINE (J%,0) - (J%,5)
1090 NEXT J%
1100 REM DRAW TICKS ON Y AXIS
1110 FOR J%=-100 TO 100 STEP 10
1120 LINE (0,J%)-(PTS%/100,J%)
1130 NEXT J%
1140 NEXT I%
1150 VIEW (30,47)-(620,348),,15
1160 RETURN
1170 REM *****
1180 REM          LABELLING OF PLOTS
1190 REM *****
1200 LOCATE 5,7
1210 PRINT"Flex"
1220 LOCATE 12,7
1230 PRINT "Left"
1240 LOCATE 13,7
1250 PRINT "Bend"
1260 LOCATE 19,7
1270 PRINT "Left"
1280 LOCATE 20,7
1290 PRINT "Twist"
1300 LOCATE 2,40
1310 PRINT "X-AXIS ONE DIVISION = 1 Second"
1320 LOCATE 3,40
1330 PRINT "Y-AXIS ONE DIVISION = 10 Degrees"
1340 RETURN
1350 REM *****y*****
1360 REM *** PLOT GRAPHS ***
1370 REM *****
1380 COLOR 10
1390 FOR I%=1 TO 3
1400 VIEW (100,50+(I%-1)*95+(I%-1)*5)-(600,50+I%*95+(I%-1)*5)
1410 WINDOW (0,-100/MAG%)-(PTS%,100/MAG%)
1420 PSET(0,0)
1430 FOR J%=2 TO POINTS%
1440 LINE -(J%-1,ANG(J%,I%))
1450 NEXT J%
1460 NEXT I%
1470 COLOR 15
1480 VIEW (30,47)-(620,348),,15
1490 RETURN
1500 REM *****
1510 REM *** ROUTINES FOR NORMALISED PLOTS ***
1520 REM *****
1530 REM
1540 REM *** FIND POINT NUMBERS FOR MAX MIN AND ZERO ***
1550 MAXN%=0
1560 MINN%=0
1570 ZERON%=0
1580 LOCATE 1,1:PRINT"Which is PRIME MOVEMENT ? 1 = F/E, 2 = BEND, 3
= TWIST

```



```

1590 P$=INPUT$(1)
1600 MAG%=1:MFLAG%=0
1610 IF P$<>"1" AND P$<>"2" AND P$<>"3" THEN GOTO 1580 ELSE P%=VAL(P$)
1620 IF P%<>1 THEN MAG%=2
1630 LOCATE 1,1:PRINT"NORMALISING ON ";P%;"
1635 IF MTEST%<>MAG% THEN MTEST%=MAG%:MFLAG%=1
1640 FOR I%=2 TO POINTS%
1650 IF ANG(I%,P%) > ANG(MAXN%,P%) THEN MAXN%=I%
1660 IF ANG(I%,P%) < ANG(MINN%,P%) THEN MINN%=I%
1670 NEXT I%
1680 MAX=ANG(MAXN%,P%)
1690 MIN=ANG(MINN%,P%)
1700 REM *** IF MINN% OCCURS FIRST SWOP MINN AND MAXN FOR LATER
ALGORITHM ***
1710 IF MINN% < MAXN% THEN TEMP%=MINN%:MINN%=MAXN%:MAXN%=TEMP%
1720 REM *** FIND FIRST ZERO CROSSING BETWEEN MAX AND MIN ***
1730 FOR I%=MAXN%+1 TO MINN%-2
1740 IF (ANG(I%,P%) >= 0 AND ANG(I%+1,P%) < 0) OR (ANG(I%,P%) <= 0
AND ANG(I%+1,P%) > 0) THEN ZERON%=I%
1750 NEXT I%
1760 REM *****
1770 REM *** FOUR PARTS OF NORMALISED GRAPH ***
1780 REM *****
1790 REM *** 1ST QUARTER ***
1800 INC = (MAXN%-1)/(POINTS%/4-1)
1810 N1%=2:N2%=INT(POINTS%/4)
1820 REM *** COPE WITH FIRST POINT HAVING INDEX 1 NOT ZERO ***
1830 INDEX%=1
1840 GOSUB 2010
1850 REM *** 2ND QUARTER ***
1860 INC = (ZERON%-MAXN%)/(POINTS%/4)
1870 N1%=INT(POINTS%/4)+1:N2%=INT(POINTS%/2)
1880 GOSUB 2010
1890 REM *** 3RD QUARTER ***
1900 INC = (MINN%-ZERON%)/(POINTS%/4)
1910 N1%=INT(POINTS%/2)+1:N2%=INT(POINTS%*3/4)
1920 GOSUB 2010
1930 REM *** 4TH QUARTER ***
1940 INC = (POINTS%-MINN%)/(POINTS%/4)
1950 N1%=INT(POINTS%*3/4)+1:N2%=POINTS%
1960 COL%=11
1970 GOSUB 2010:REM NORMALISATION
1980 GOSUB 2170:REM PLOTTING OF NORMALISED DATA
1990 GOSUB 2320:REM LOAD NMEAN ARRAY
2000 RETURN
2010 REM *****
2020 REM *** NORMALISATION ***
2030 REM *****
2040 REM
2050 TEMP%=INDEX%+INT(INC):REM PRINT TEMP%
2060 FOR I%=1 TO 3
2070 INDEX%=TEMP%
2080 MULT=-INT(INC)
2090 FOR J%=N1% TO N2%
2100 MULT=MULT+INC:IF (MULT-INT(MULT)) > .99 THEN MULT = CINT(MULT)
2110 IF MULT >= 1! THEN INDEX%=INDEX%+INT(MULT):MULT=MULT-INT(MULT)
2120 REM PRINT "J%=";J%;" INDEX%=";INDEX%;" MULT=";MULT;" INC=";INC
2130 NORM(J%,I%)=ANG(INDEX%,I%)+MULT*(ANG(INDEX%+1,I%)-
ANG(INDEX%,I%))

```

```

2140 NEXT J%
2150 NEXT I%
2160 RETURN
2170 REM *****
2180 REM *** PLOT GRAPHS ***
2190 REM *****
2192 IF MFLAG%=0 AND FLAG%=1 AND COUNT%<>1 THEN GOTO 2200
2194 CLS
2196 GOSUB 980:REM AXES
2198 GOSUB 1170:REM LABELS
2200 COLOR COL%
2210 FOR I%=1 TO 3
2220 VIEW (100,50+(I%-1)*95+(I%-1)*5)-(600,50+I%*95+(I%-1)*5)
2230 WINDOW (0,-100/MAG%)-(PTS%,100/MAG%)
2240 PSET(0,0)
2250 FOR J%=2 TO POINTS%
2260 LINE -(J%-1,NORM(J%,I%))
2270 NEXT J%
2280 NEXT I%
2290 COLOR 15
2300 VIEW (30,47)-(620,348),,15
2310 RETURN
2320 REM *****
2330 REM ROUTINE TO LOAD NMEAN FOR CALCULATING MEAN NORMALISED
DATA
2340 REM *****
2350 LOCATE 1,1:PRINT"Loading NMEAN "
2360 FOR I%=2 TO POINTS%
2370 FOR J%=1 TO 3
2380 NMEAN(I%,J%)=NMEAN(I%,J%)+NORM(I%,J%)
2390 SDEV(I%,J%)=SDEV(I%,J%)+(NORM(I%,J%)^2)
2400 NEXT J%
2410 NEXT I%
2420 RETURN
2430 REM *****
2440 REM DIVIDE NMEAN BY COUNT% LOAD INTO NORM FOR PLOTTING
2450 REM *****
2460 LOCATE 1,1:PRINT"Calculating MEAN values "
2470 FOR I%=2 TO POINTS%
2480 FOR J%=1 TO 3
2490 NORM(I%,J%)=NMEAN(I%,J%)/COUNT%
2500 SDEV(I%,J%)=SQR(SDEV(I%,J%)/COUNT%-(NORM(I%,J%)^2))
2510 NEXT J%
2520 NEXT I%
2530 LOCATE 1,1:PRINT " "
2540 LOCATE 1,1:PRINT"DO YOU WISH TO SAVE MEANS AND SDs ?"
2550 N$=INPUT$(1):IF N$<>"Y" AND N$<>"y" THEN GOTO 2570
2560 GOSUB 2770:REM SAVE MEANS AND SDS TO DISC FILE
2570 COL%=12
2580 GOSUB 2200
2590 LOCATE 1,1:PRINT " "
2600 LOCATE 1,1:PRINT"Plotting +2 SDs"
2610 FOR I%=2 TO POINTS%
2620 FOR J%=1 TO 3
2630 NORM(I%,J%)=NORM(I%,J%)+2*SDEV(I%,J%)
2640 NEXT J%
2650 NEXT I%
2660 GOSUB 2200

```

```

2670 LOCATE 1,1:PRINT "
2680 LOCATE 1,1:PRINT"Plotting -2 SDs"
2690 FOR I%=2 TO POINTS%
2700 FOR J%=1 TO 3
2710 NORM(I%,J%)=NORM(I%,J%)-4*SDEV(I%,J%)
2720 NEXT J%
2730 NEXT I%
2740 GOSUB 2200
2750 COL%=15
2760 RETURN
2770 REM *****
2780 REM ROUTINE TO SAVE MEANS AND SDS TO DISC FILE
2790 REM *****
2800 LOCATE 1,1:PRINT"
2810 LOCATE 1,1:INPUT"Name of FILE to save data in :- ";NAM$
2820 DNAME$=D$+" "+NAM$+".NOR"
2830 LOCATE 1,1:PRINT "
2840 LOCATE 1,1:INPUT"Title of data file :- ";TITLE$
2850 OPEN DNAME$ FOR OUTPUT AS #2
2860 PRINT#2,TITLE$
2870 PRINT#2,SEX$;" ";AGE$;" ";MAG$;" ";HT$;" ";WT
2880 PRINT#2,FREQ$;" ";TIME$;" ";POINTS%
2885 PRINT#2,COUNT%
2890 FOR I%=1 TO POINTS%
2900 PRINT#2,NORM(I%,1);" ";NORM(I%,2);" ";NORM(I%,3);" ";
SDEV(I%,1);" ";SDEV(I%,2);" ";SDEV(I%,3):REM 1-FLEX,2-BEND,3-TWIST
2910 NEXT I%
2920 CLOSE #2
2930 RETURN

```

```

10 REM *****
20 REM MEANPLT.BAS
30 REM PROGRAM TO READ IN MEAN DATA AND PRODUCE
40 REM PLOTS
50 REM MJP DEC 88
60 REM *****
70 ON ERROR GOTO 1270
80 KEY OFF
90 DIM MEAN(1000,3),SDEV(1000,3)
100 SCREEN 0:WIDTH 80
110 FLAG%=0
120 CLS
130 LOCATE 1,1:INPUT "Which disc drive is the data file on [A]";D$
140 IF D$<>"A" AND D$<>"B" AND D$<>"C" AND D$<>"D" AND D$<>" " THEN
GOTO 130
150 IF D$="" THEN D$="A"
160 INPUT "INPUT THE FILENAME";NAM$
170 DNAME$=D$+" "+NAM$+".NOR"
180 OPEN DNAME$ FOR INPUT AS #2
190 INPUT#2,SNAME$
200 INPUT#2,SEX$,AGE%,MAG%,HT,WT
210 INPUT#2,FREQ%,TIME%,POINTS%
215 INPUT#2,NUM%
220 FOR I%=1 TO POINTS%
230 INPUT#2,MEAN(I%,1),MEAN(I%,2),MEAN(I%,3),SDEV(I%,1),SDEV(I%,2)
,SDEV(I%,3) :REM 1-FLEX,2-BEND,3-TWIST
240 NEXT I%
250 CLOSE #2
260 IF FLAG%=1 THEN GOTO 530
270 REM *****
280 REM DATA ANALYSIS
290 REM *****
300 CLS
310 COLOR 7,1
320 PRINT "*****"
330 PRINT " DATA IS:- "SNAME$
340 PRINT "SEX;";SEX$
350 PRINT "AGE;";AGE%
360 PRINT "MAGNIFICATION=";MAG%
370 PRINT "HEIGHT=";HT;"M"
380 PRINT "WEIGHT=";WT;"KG"
390 PRINT "*****"
400 PRINT "DATA COLLECTION FREQUENCY=";FREQ%;"Hz FOR";TIME%;"Secs"
410 PRINT " (";POINTS%;"DATA POINTS)"
420 PRINT "*****"
430 PRINT
440 PRINT "PRESS RETURN TO CONTINUE"
450 Q$=INKEY$
460 IF LEN(Q$)=0 THEN GOTO 450
470 IF ASC(Q$)<>13 THEN GOTO 450
480 REM *****
490 REM GRAPH DRAWING SECTION
500 REM *****
510 CLS
520 SCREEN 9
530 LOCATE 1,1:PRINT"
540 LOCATE 1,1:PRINT "DATA IS:- "SNAME$
550 REM *****
560 REM SET UP 3 WINDOWS AND PLOT THE 3 ANGLES

```

```

570 REM *****
580 PTS%=POINTS%-1:REM AS FIRST POINT IS 0,0
590 FOR I%=1 TO 3
600 AREA=0!
610 VIEW (100,50+(I%-1)*95+(I%-1)*5)-(600,50+I%*95+(I%-1)*5)
620 WINDOW (0,-100/MAG%)-(PTS%,100/MAG%)
630 REM DRAW AXES
640 LINE (0,0)-(PTS%,0):LINE(0,-100)-(0,100):REM X AND Y AXES
650 REM DRAW TICKS ON X AXIS
660 FOR J% = PTS%/10 TO PTS% STEP PTS%/10
670 LINE (J%,0) - (J%,5)
680 NEXT J%
690 REM DRAW TICKS ON Y AXIS
700 FOR J%=-100 TO 100 STEP 10
710 LINE (0,J%)-(PTS%/100,J%)
720 NEXT J%
730 REM PLOT GRAPHS
740 PSET (0,0)
750 FOR J%=2 TO POINTS%
760 LINE -(J%-1,MEAN(J%,I%))
770 NEXT J%
780 PSET (0,0)
790 FOR J%=2 TO POINTS%
800 LINE -(J%-1,MEAN(J%,I%)+2*SDEV(J%,I%))
810 NEXT J%
820 PSET (0,0)
830 FOR J%=2 TO POINTS%
840 LINE -(J%-1,MEAN(J%,I%)-2*SDEV(J%,I%))
850 AREA=AREA+4*SDEV(J%,I%)
860 NEXT J%
870 REM LOCATE 5+(I%-1)*7,40
880 REM PRINT USING "Enclosed AREA = £££££.£";AREA
890 NEXT I%
900 VIEW (30,47)-(620,348),,7
910 REM *****
920 REM LABELLING OF PLOTS
930 REM *****
940 LOCATE 5,7
950 PRINT"Flex"
960 LOCATE 12,7
970 PRINT "Left"
980 LOCATE 13,7
990 PRINT "Bend"
1000 LOCATE 19,7
1010 PRINT "Left"
1020 LOCATE 20,7
1030 PRINT "Twist"
1040 LOCATE 2,40
1050 PRINT"X-AXIS ONE DIVISION=1 Second"
1060 LOCATE 3,40
1070 PRINT "Y-AXIS ONE DIVISION=10 Degrees"
1080 IF MAG%=2 THEN LOCATE 3,40:PRINT"Y-AXIS ONE DIVISION=5 Degrees"
"
1090 LOCATE 1,1:PRINT"
"
1100 LOCATE 1,1:PRINT" ANOTHER FILE Y/N? "
1110 FLAG%=0
1120 N$=INPUT$(1):IF N$<>"Y" AND N$<>"y" THEN GOTO 1180
1130 FLAG%=1

```

```

1140 LOCATE 1,1:PRINT "DO YOU WISH TO OVERLAY Y/N ?"
1150 N$=INPUT$(1):IF N$="Y" OR N$="y" THEN GOTO 1170
1160 CLS
1170 GOTO 160
1180 LOCATE 1,1:PRINT "Press SPACE BAR once TO CLEAR"
1190 LOCATE 2,1:PRINT "twice to return to MENU"
1200 N$=INPUT$(1):IF N$<>" " THEN GOTO 1200
1210 LOCATE 1,1:PRINT "
"
1220 LOCATE 1,5:PRINT SNAME$
1230 LOCATE 2,1:PRINT "
"
1240 N$=INKEY$:IF LEN(N$)=0 THEN GOTO 1240:IF ASC(N$)<>32 THEN GOTO
1240
1250 CHAIN"C:\ISOTRAK\MENU"
1260 END
1270 REM *** FILE OPEN ERROR ROUTINE ***
1280 IF (ERR = 53 ) THEN GOTO 1290 ELSE IF (ERR = 71) THEN GOTO
1290 ELSE END
1290 LOCATE 1,1:PRINT " FILE NOT FOUND - CHECK THE DISC "
1300 LOCATE 2,1
1310 INPUT "PRESS ANY KEY TO CONTINUE",ANS$
1320 LOCATE 1,1:PRINT "
"
1330 LOCATE 2,1:PRINT "
";
1340 RESUME 190

```

```

10 REM *****
20 REM  TPL0T.BAS
30 REM  PROGRAM TO READ IN MEAN DATA AND PRODUCE
40 REM  T-STATISTIC
50 REM  RJH MAR 89
60 REM *****
70 ON ERROR GOTO 1760
80 KEY OFF
90 DIM MEAN(500,3),SDEV(500,3)
100 DIM MEANB(500,3),SDEVB(500,3)
110 DIM TSTAT(500,3)
120 SCREEN 0:WIDTH 80
130 FLAG%=0
140 CLS
150 LOCATE 1,1:INPUT "Which disc drive are the data files on [A]";D$
160 IF D$<>"A" AND D$<>"B" AND D$<>"C" AND D$<>"D" AND D$<>" " THEN
GOTO 150
170 IF D$="" THEN D$="A"
180 INPUT "INPUT THE FILENAME";NAM$
190 DNAME$=D$+" ":"+NAM$+".NOR"
200 OPEN DNAME$ FOR INPUT AS #2
210 INPUT#2,SNAME$
220 INPUT#2,SEX$,AGE%,MAG%,HT,WT
230 INPUT#2,FREQ%,TIME%,POINTS%
235 INPUT#2,NA%
240 FOR I%=1 TO POINTS%
250 INPUT#2,MEAN(I%,1),MEAN(I%,2),MEAN(I%,3),SDEV(I%,1),SDEV(I%,2),
SDEV(I%,3) :REM 1-FLEX,2-BEND,3-TWIST
260 NEXT I%
270 CLOSE #2
280 CLS
290 LOCATE 1,1:INPUT "INPUT THE SECOND FILENAME";NAMB$
300 DNAMEB$=D$+" ":"+NAMB$+".NOR"
310 OPEN DNAMEB$ FOR INPUT AS #2
320 INPUT#2,SNAMEB$
330 INPUT#2,SEXB$,AGEB%,MAG%,HT,WT
340 INPUT#2,FREQ%,TIME%,POINTS%
345 INPUT#2,NB%
350 FOR I%=1 TO POINTS%
360 INPUT#2,MEANB(I%,1),MEANB(I%,2),MEANB(I%,3),SDEVB(I%,1),
SDEVB(I%,2),SDEVB(I%,3)
370 NEXT I%
380 CLOSE #2
390 IF FLAG%=1 THEN GOTO 640
400 REM *****
410 REM DATA ANALYSIS
420 REM *****
430 CLS
440 COLOR 7,1
450 PRINT "*****"
460 PRINT "DATA IS:- "SNAME$
470 PRINT "AND"
480 PRINT SNAMEB$
490 PRINT "MAGNIFICATION=";MAG%
500 PRINT "*****"
510 PRINT "DATA COLLECTION FREQUENCY=";FREQ%;"Hz FOR";TIME%;"Secs"
520 PRINT " (";POINTS%;"DATA POINTS)"
530 PRINT "*****"
540 PRINT

```

```

550 PRINT "PRESS RETURN TO CONTINUE"
560 Q$=INKEY$
570 IF LEN(Q$)=0 THEN GOTO 560
580 IF ASC(Q$)<>13 THEN GOTO 560
590 REM *****
600 REM GRAPH DRAWING SECTION
610 REM *****
620 CLS
630 SCREEN 9
640 LOCATE 1,1:PRINT
650 LOCATE 1,1:PRINT "PRESS RETURN TO CONTINUE"
660 REM *****
670 REM SET UP 3 WINDOWS AND PLOT THE 3 ANGLES
680 REM *****
690 PTS%=POINTS%-1:REM AS FIRST POINT IS 0,0
700 FOR I%=1 TO 3
710 AREA=0!
720 VIEW (100,50+(I%-1)*95+(I%-1)*5)-(600,50+I%*95+(I%-1)*5)
730 WINDOW (0,-100/MAG%)-(PTS%,100/MAG%)
740 REM DRAW AXES
750 LINE (0,0)-(PTS%,0):LINE(0,-100)-(0,100):REM X AND Y AXES
760 REM DRAW TICKS ON X AXIS
770 FOR J% = PTS%/10 TO PTS% STEP PTS%/10
780 LINE (J%,0) - (J%,5)
790 NEXT J%
800 REM DRAW TICKS ON Y AXIS
810 FOR J%=-100 TO 100 STEP 10
820 LINE (0,J%)-(PTS%/100,J%)
830 NEXT J%
840 REM PLOT GRAPHS
850 PSET (0,0)
860 FOR J%=2 TO POINTS%
870 LINE -(J%-1,MEAN(J%,I%)),2
880 NEXT J%
890 PSET (0,0)
900 FOR J%=2 TO POINTS%
910 LINE -(J%-1,MEANB(J%,I%)),3
920 NEXT J%
930 PSET (0,0)
940 NEXT I%
950 VIEW (30,47)-(620,348),,7
960 REM *****
970 REM LABELLING OF PLOTS
980 REM *****
990 LOCATE 5,7
1000 PRINT"Flex"
1010 LOCATE 12,7
1020 PRINT "Left"
1030 LOCATE 13,7
1040 PRINT "Bend"
1050 LOCATE 19,7
1060 PRINT "Left"
1070 LOCATE 20,7
1080 PRINT "Twist"
1090 LOCATE 2,40
1100 PRINT"X-AXIS ONE DIVISION=1 Second"
1110 LOCATE 3,40
1120 PRINT "Y-AXIS ONE DIVISION=10 Degrees"
1130 Q$=INKEY$

```



```

1140 IF LEN(Q$)=0 THEN GOTO 1130
1150 IF ASC(Q$)<>13 THEN GOTO 1130
1160 REM *****
1170 REM      CALCULATION OF T-VALUES
1180 REM *****
1190 CLS
1200 LOCATE 2,35
1210 PRINT"X-AXIS ONE DIVISION=1 SECOND          "
1220 LOCATE 3,35
1230 PRINT"Y-AXIS ONE DIVISION=5 PTS OF T-DISTRIBUTION "
1260 LOCATE 1,1:INPUT "INPUT THE SIGNIFICANT T-VALUE FOR  (N1+N2-2)
D.F. ";D%
1270 FOR J%=1 TO 3
1280 FOR I%=2 TO POINTS%
1290 B=((NA%-1)*SDEV(I%,J%)*SDEV(I%,J%)+(NB%-
1)*SDEVB(I%,J%)*SDEVB(I%,J%))/(NA%+NB%-2)
1300 C=(NA%+NB%)/(NA%*NB%)
1310 ESV=SQR(B*C)
1320 TSTAT(I%,J%)=((MEAN(I%,J%)-MEANB(I%,J%))/ESV)
1330 NEXT I%
1340 NEXT J%
1350 REM *****
1360 REM      PLOT T-VALUES
1370 REM *****
1380 GOTO 1420
1390 FOR I%=2 TO POINTS%
1400 PRINT I%,TSTAT(I%,1),TSTAT(I%,2),TSTAT(I%,3)
1410 NEXT I%
1420 FOR J%=1 TO 3
1430 VIEW (100,50+(J%-1)*95+(J%-1)*5)-(600,50+J%*95+(J%-1)*5)
1440 WINDOW (0,-10)-(PTS%,10)
1450 LINE (0,0)-(PTS%,0):LINE (0,-100)-(0,100)
1460 LINE (0,D%)-(100,D%),5
1465 LINE (0,-D%)-(100,-D%),5
1470 REM DRAW TICKS ON Y AXIS
1480 FOR Z%=-10 TO 10 STEP 5
1490 LINE (0,Z%)-(1,Z%)
1500 NEXT Z%
1510 REM DRAW TICKS ON X AXIS
1520 FOR Z%=0 TO POINTS% STEP 10
1530 LINE (Z%,0)-(Z%,.5)
1540 NEXT Z%
1550 PSET (0,0)
1560 FOR I%=2 TO POINTS%
1570 LINE -(I%,TSTAT(I%,J%)),2
1580 NEXT I%
1590 NEXT J%
1600 REM *****
1610 REM      LABEL T-PLOTS
1620 REM *****
1630 LOCATE 5,7:PRINT "FLEX"
1640 LOCATE 13,7:PRINT "BEND"
1650 LOCATE 19,7:PRINT "TWIST"
1660 LOCATE 1,1:PRINT"          "
1670 LOCATE 1,1:PRINT "Press SPACE BAR once TO CLEAR"
1680 LOCATE 2,1:PRINT "twice to return to MENU"
1690 N$=INPUT$(1):IF N$<>" " THEN GOTO 1690
1700 LOCATE 1,1:PRINT "          "
1710 LOCATE 1,5:PRINT "RESULTS FOR -"NAM$" AND "NAMB$

```

```
1720 LOCATE 2,1:PRINT "
1730 N$=INKEY$:IF LEN(N$)=0 THEN GOTO 1730:IF ASC(N$)<>32 THEN GOTO 1730
1740 CHAIN"C:\ISOTRAK\MENU"
1750 END
1760 REM *** FILE OPEN ERROR ROUTINE ***
1770 IF (ERR = 53 ) THEN GOTO 1780 ELSE IF (ERR = 71) THEN GOTO 1780
ELSE END
1780 LOCATE 1,1:PRINT " FILE NOT FOUND - CHECK THE DISC "
1790 LOCATE 2,1
1800 INPUT "PRESS ANY KEY TO CONTINUE",ANS$
1810 LOCATE 1,1:PRINT "
1820 LOCATE 2,1:PRINT "
1830 RESUME 210
```

Appendix B

Regression Plots of Age on Movement

This Appendix contains regression plots of age on maximum ranges of voluntary movement in males, females and all normal subjects for flexion, extension, lateral bend and axial rotation.

REGRESSION PLOT 40 MALES FLEXING

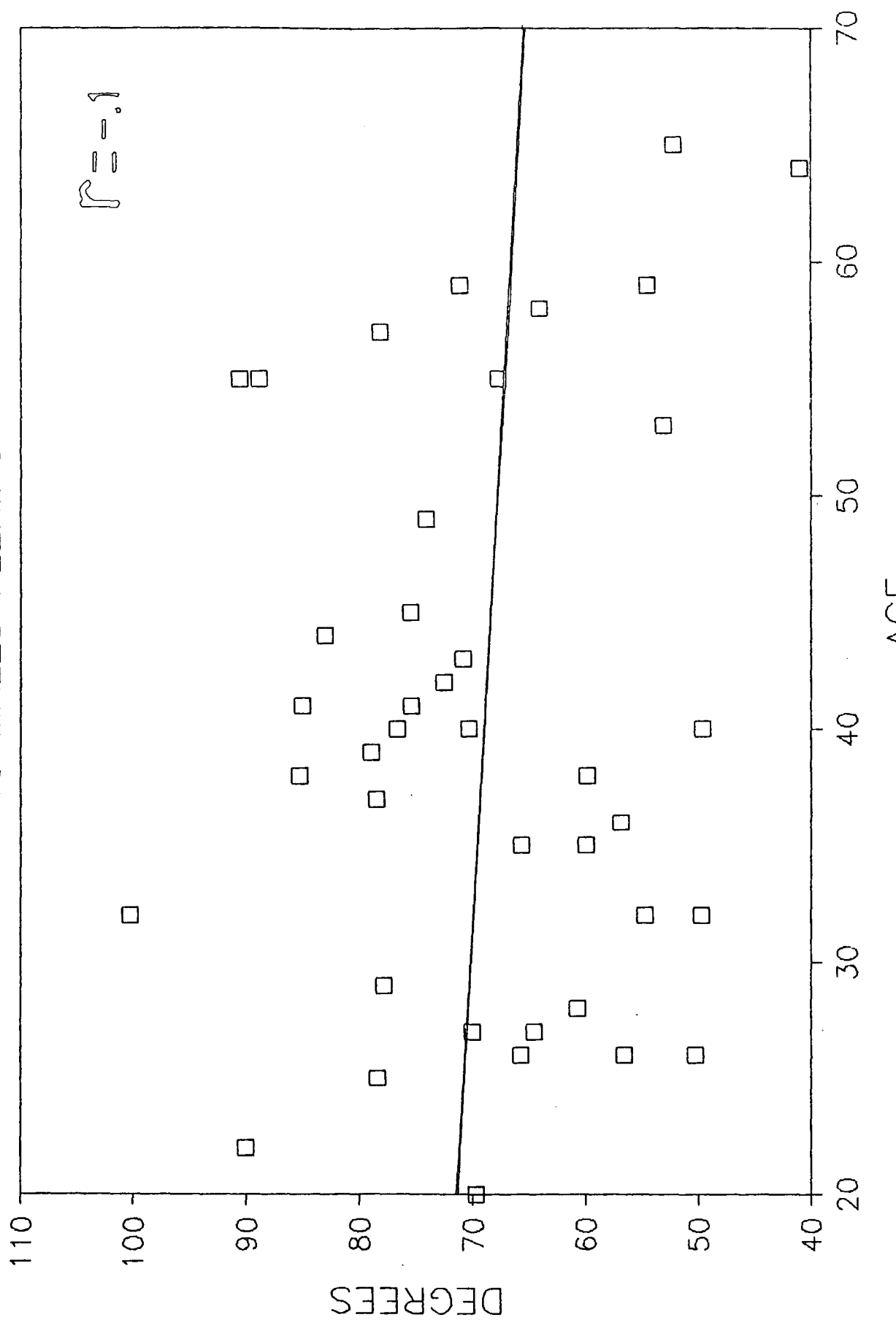

REGRESSION PLOT

40 MALES EXTENDING

207

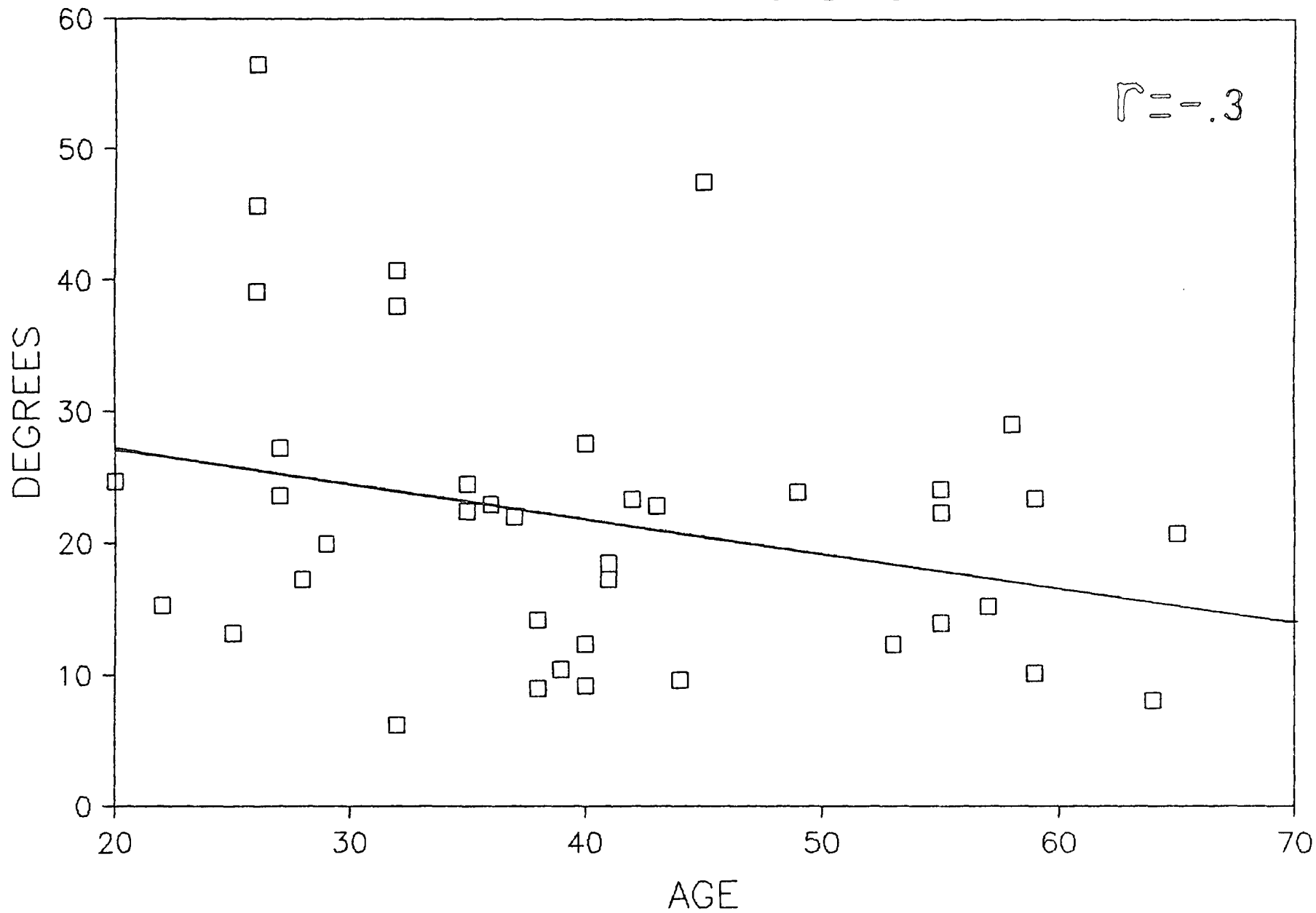

REGRESSION PLOT 40 MALES BENDING

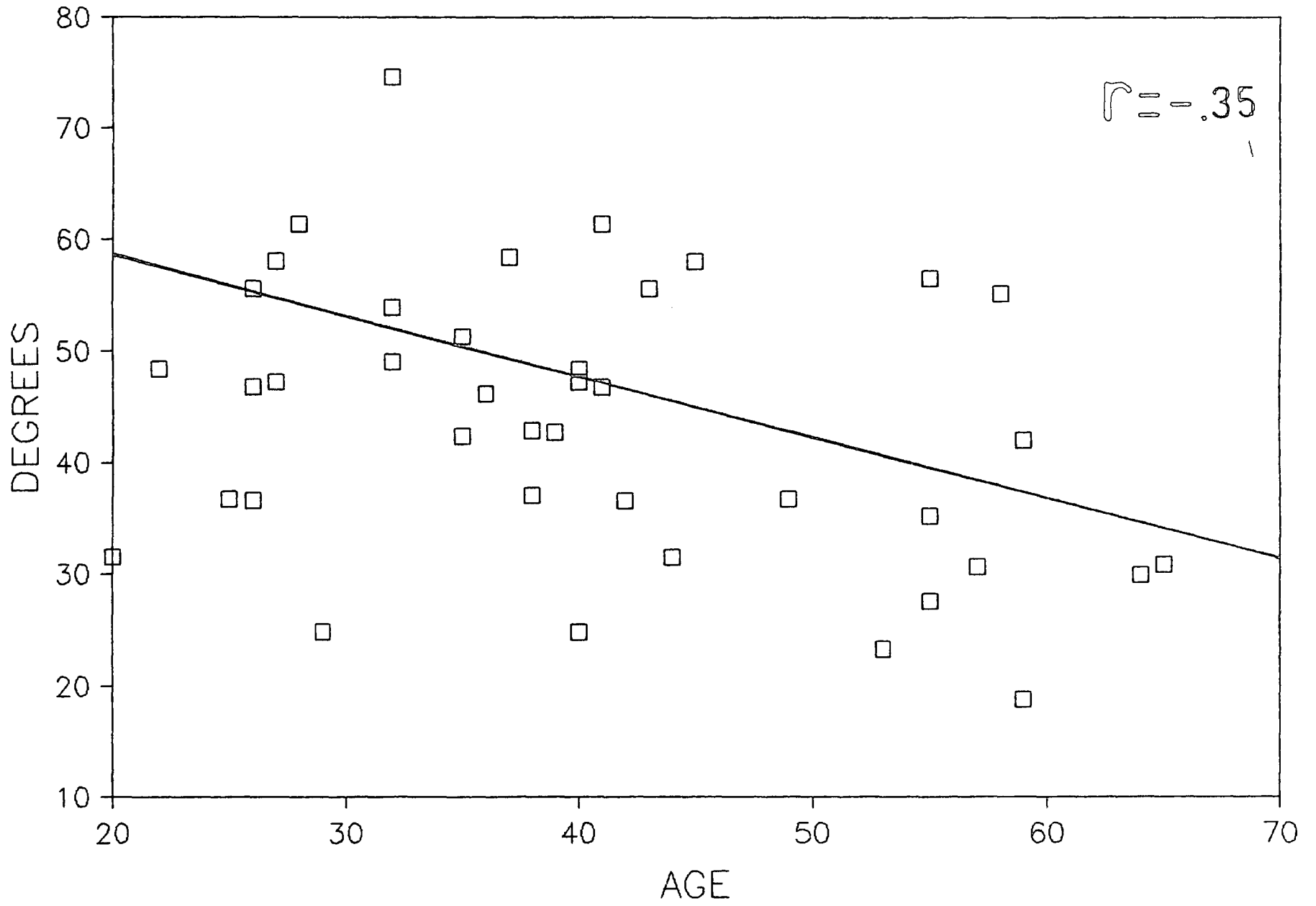

REGRESSION PLOT

40 MALES TWISTING

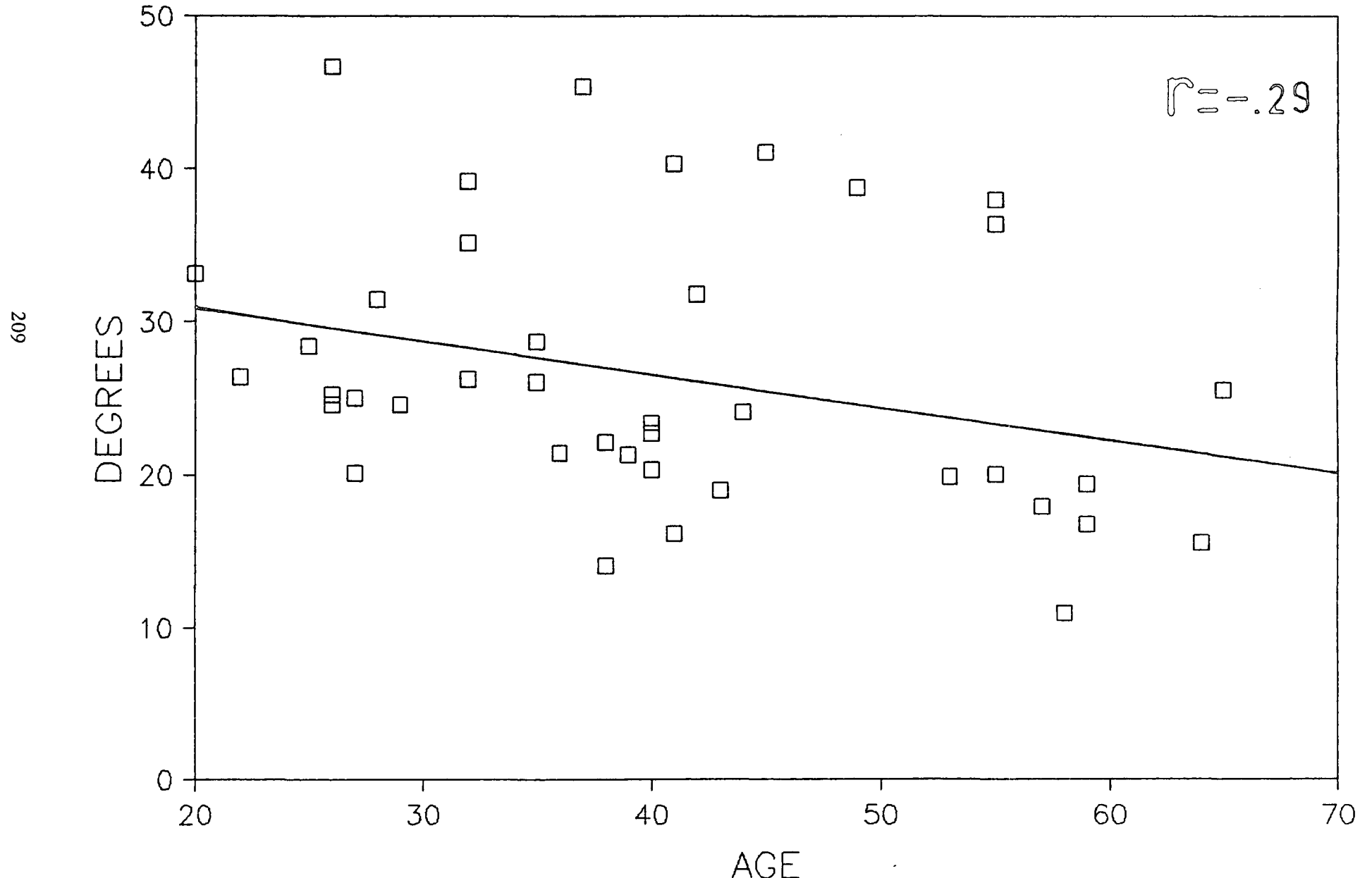

REGRESSION PLOT

40 FEMALES FLEXING

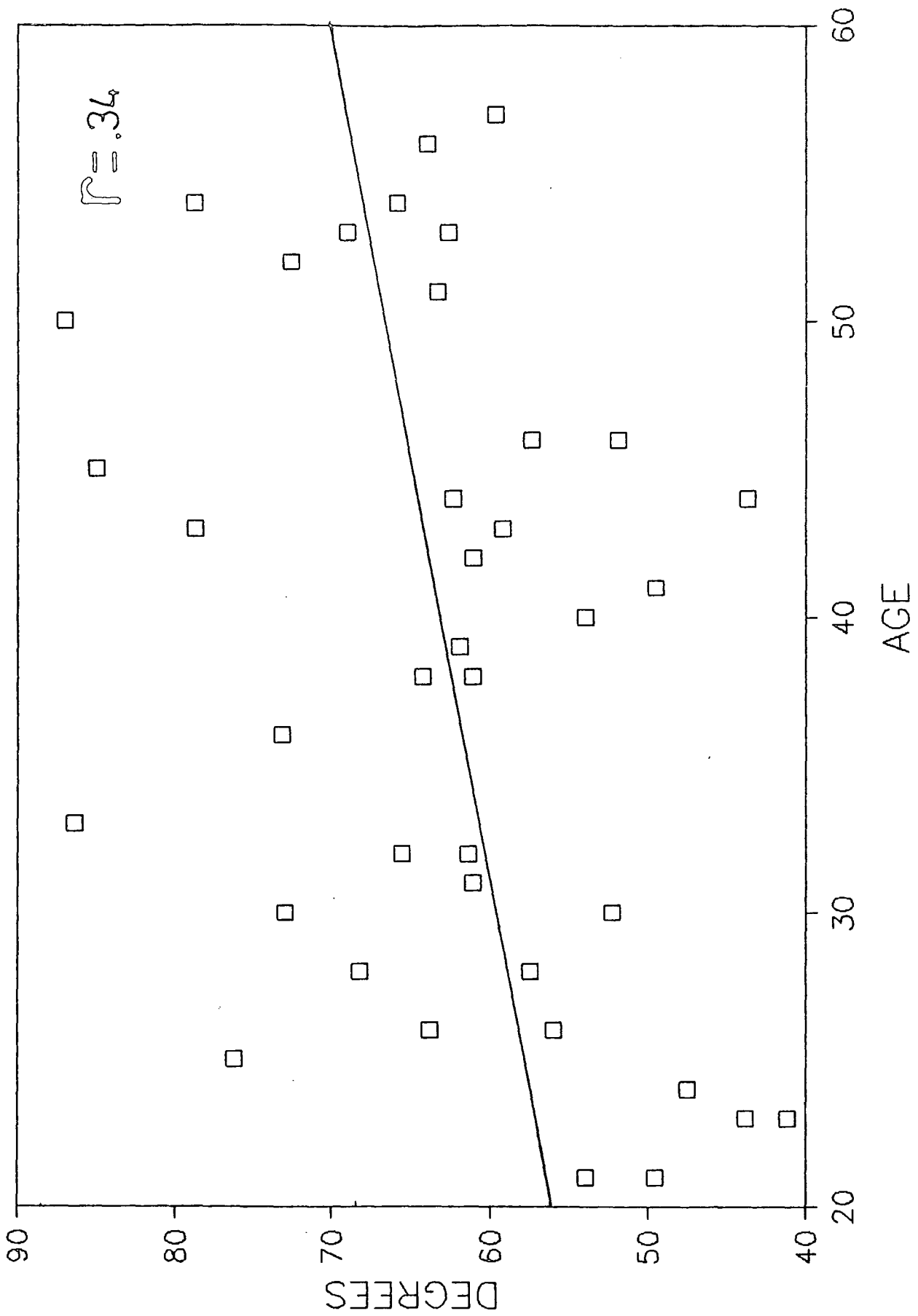

REGRESSION PLOT

40 FEMALES EXTENDING

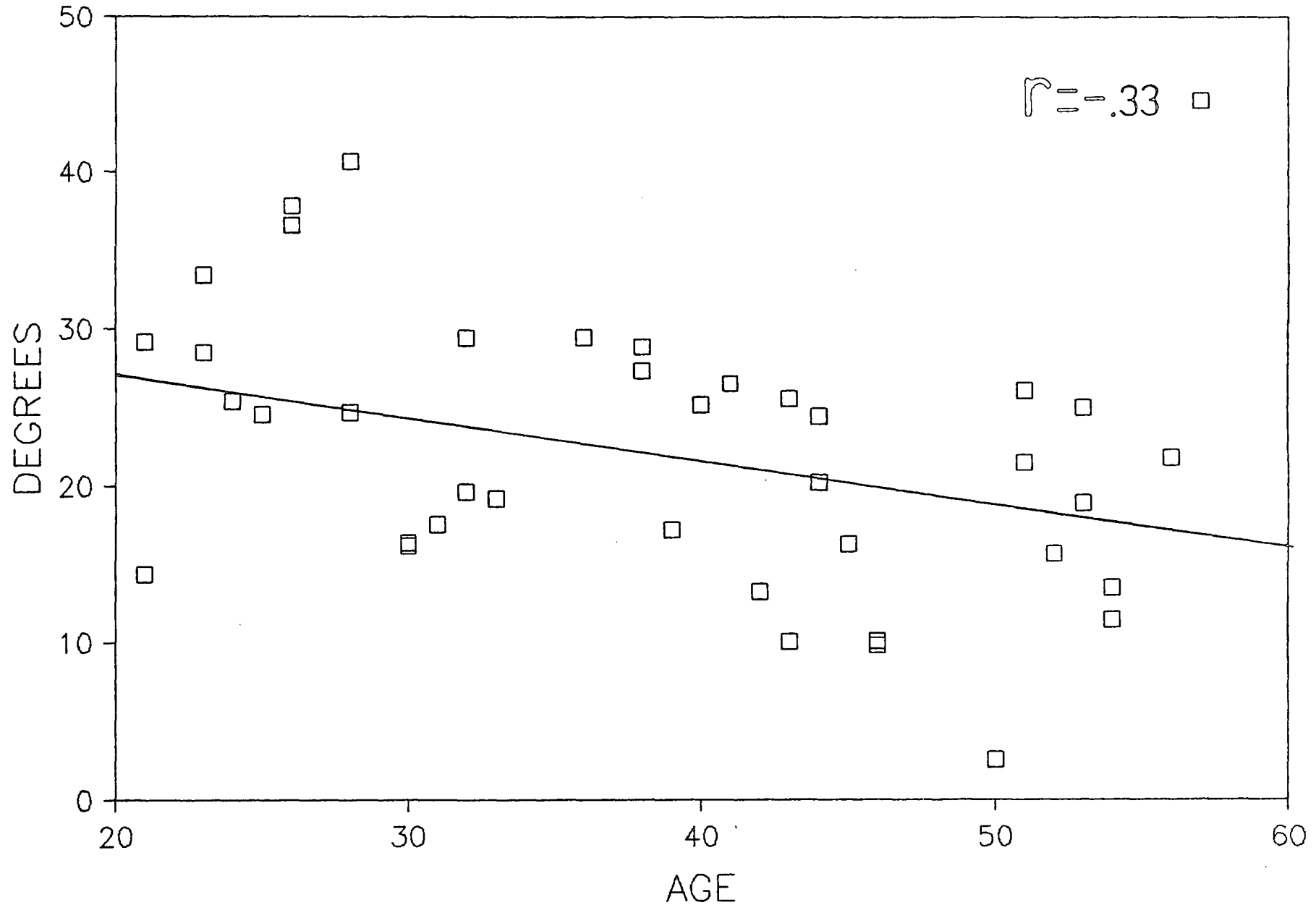

REGRESSION PLOT

40 FEMALES BENDING

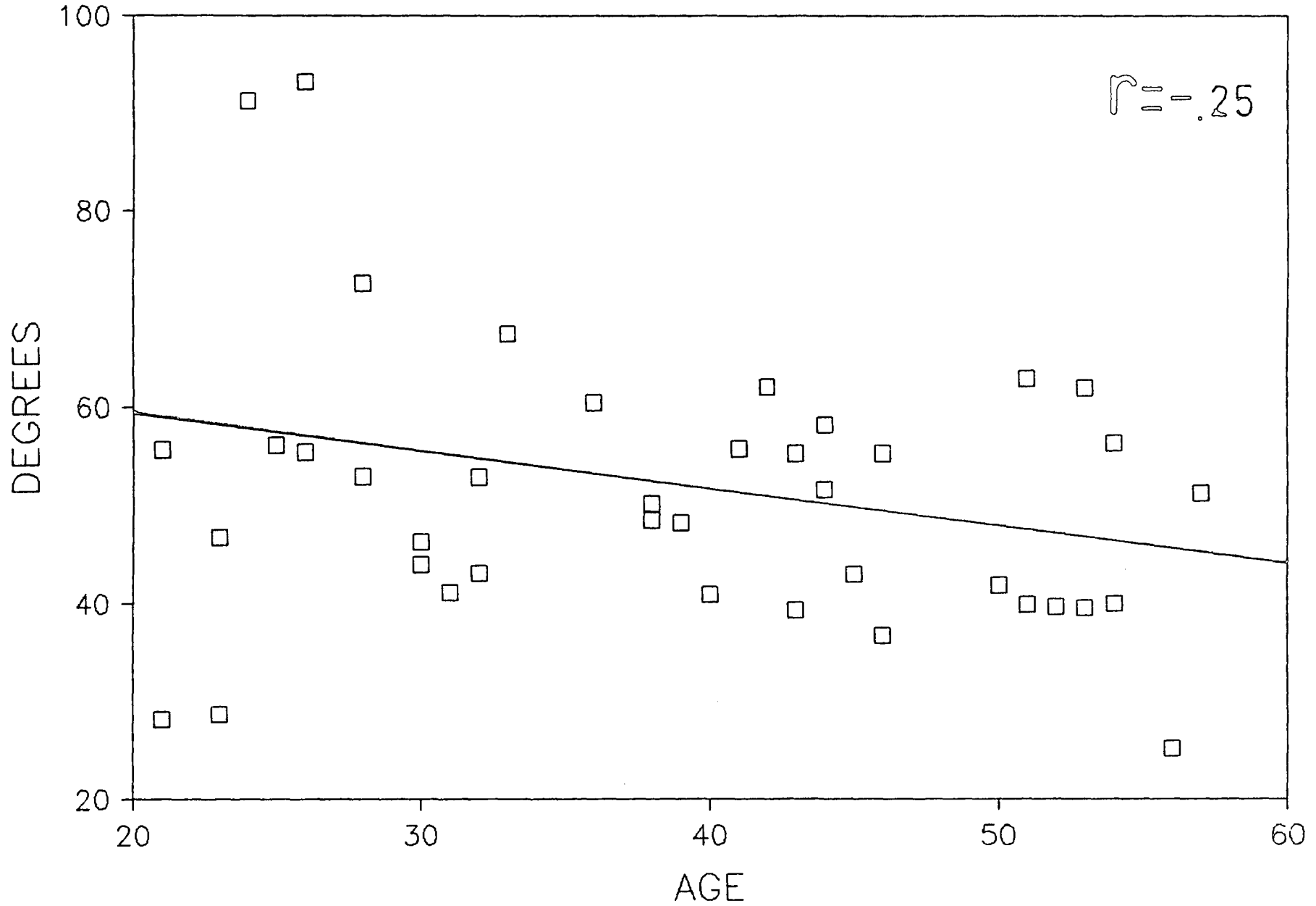

REGRESSION PLOT

40 FEMALES TWISTING

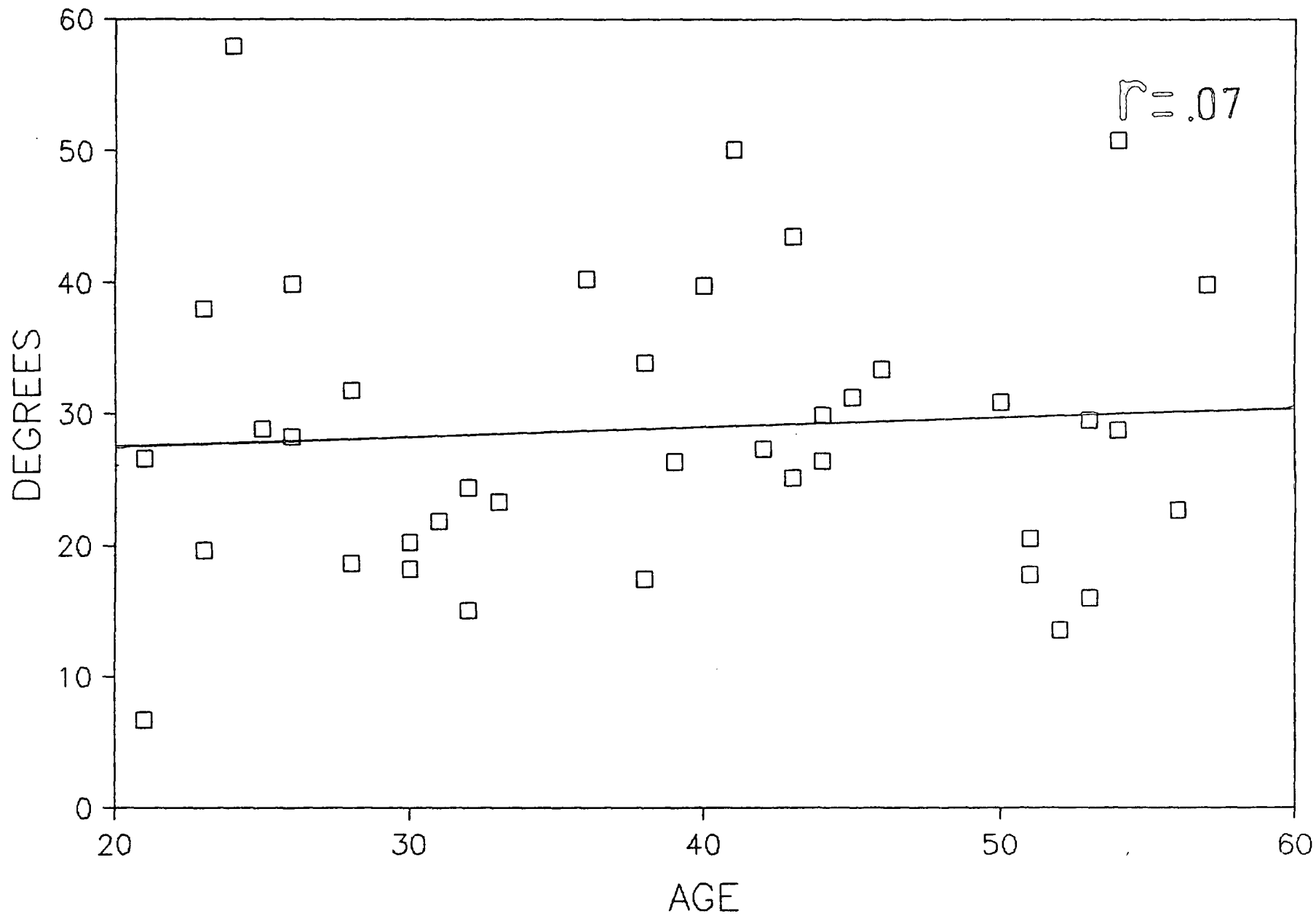

REGRESSION PLOT FLEXION-80 NORMALS

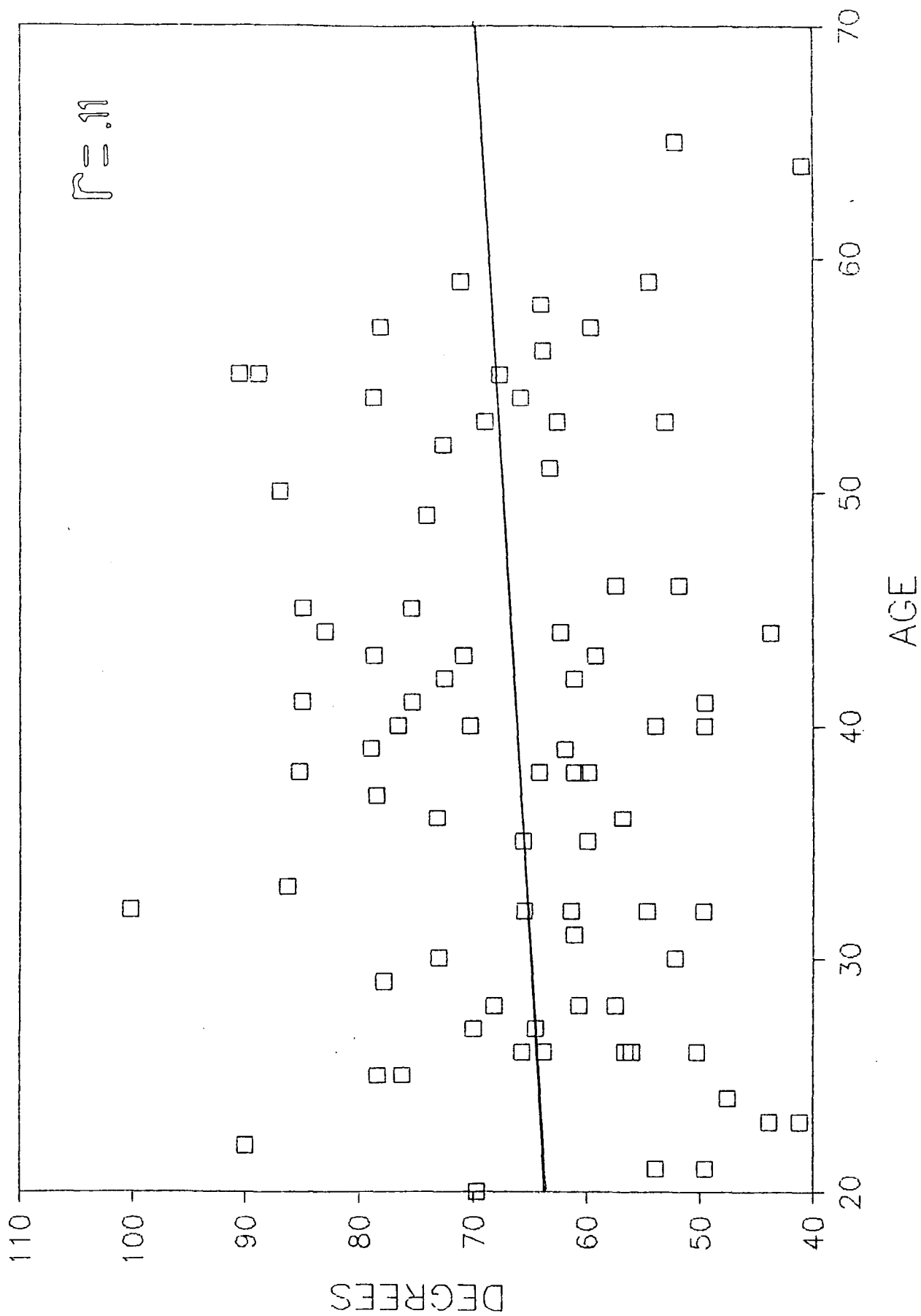

REGRESSION PLOT EXTENSION-80 NORMALS

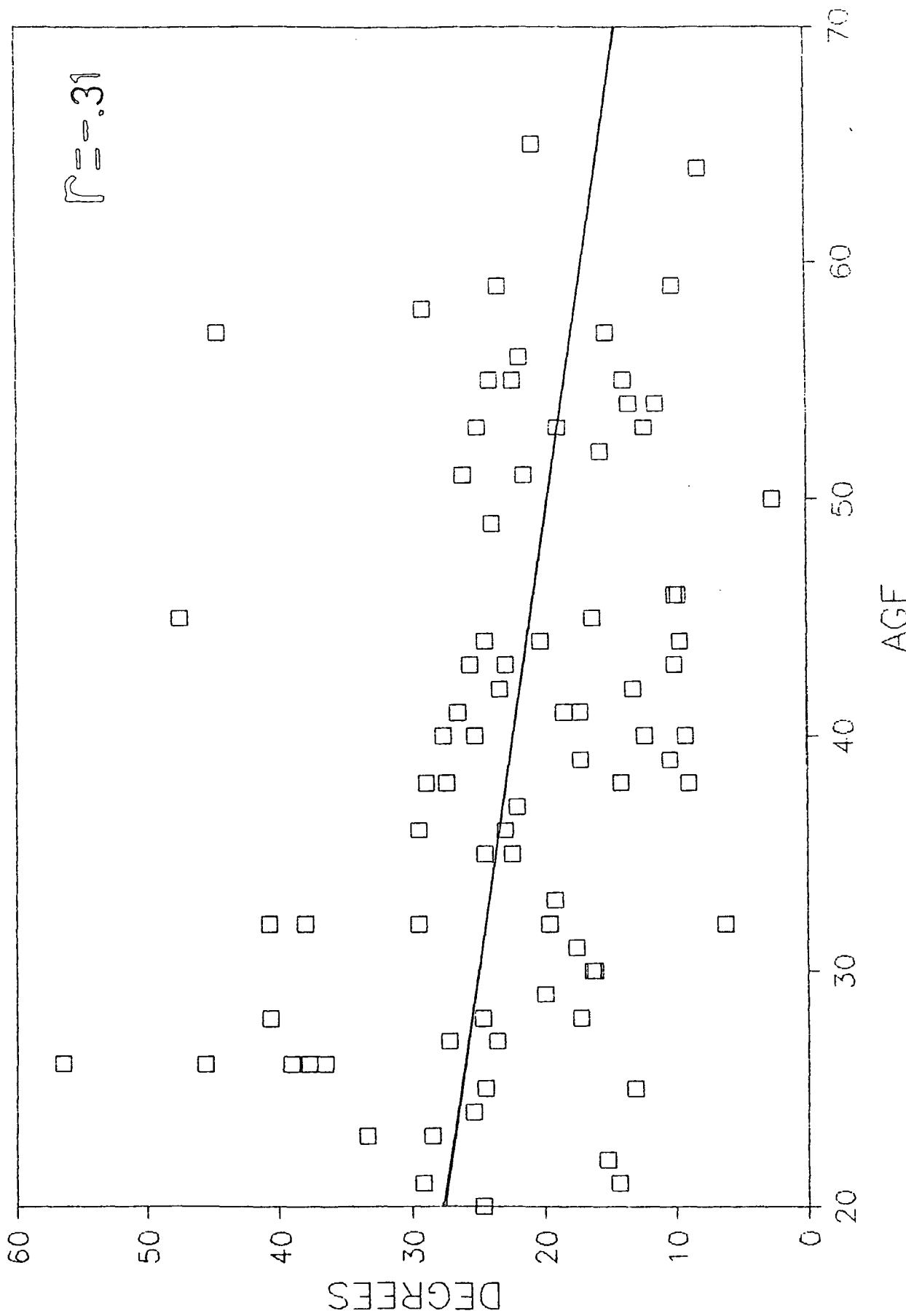

REGRESSION PLOT

BEND-80 NORMALS

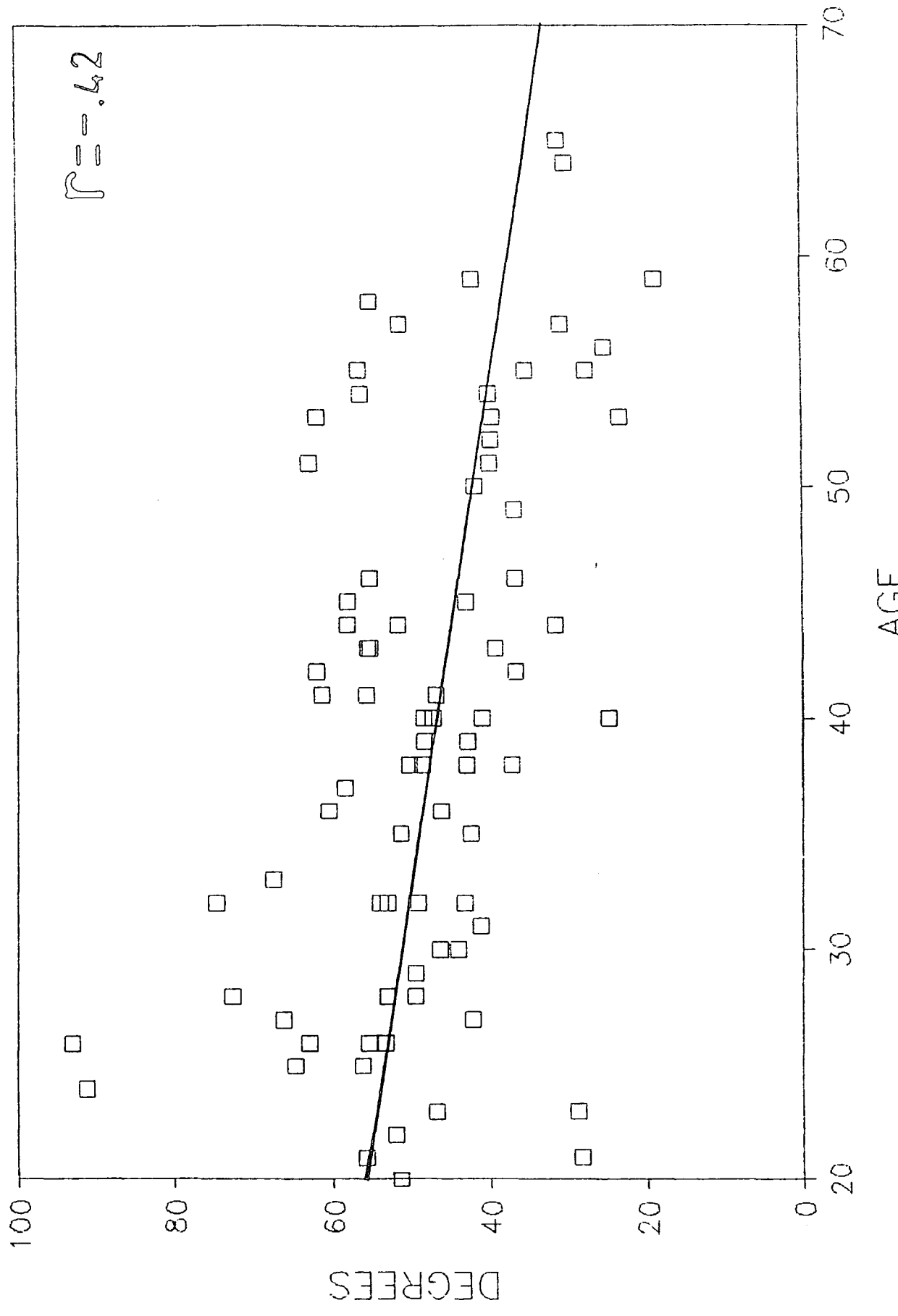

REGRESSION PLOT

TWIST-80 NORMALS

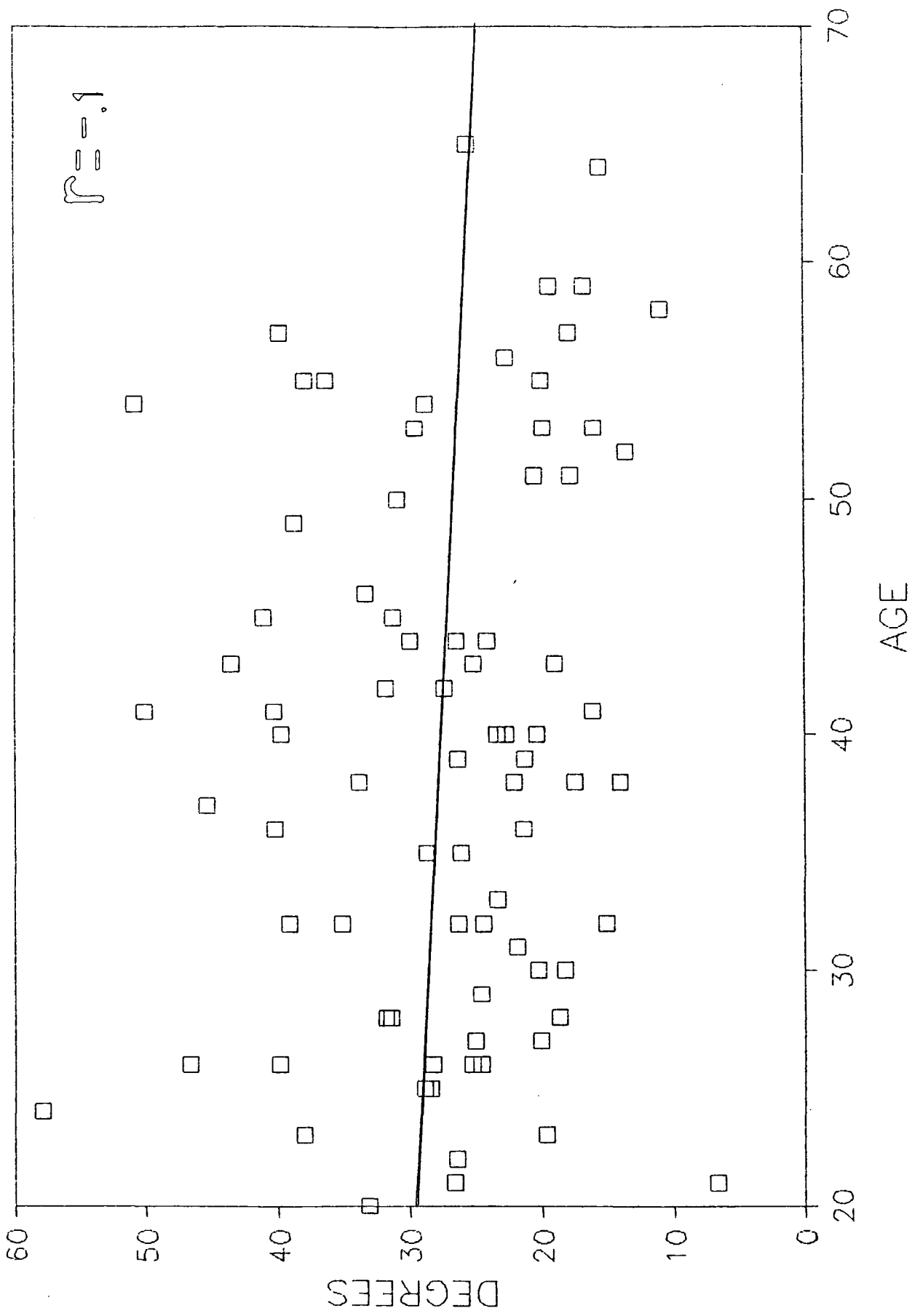

Appendix C

Normal Subject Kinematic Movement Plots

This appendix contains normalised plots of all subjects, divided by age and sex into eight groups, performing flexion-extension, lateral bend and axial rotation. The plots show the mean movement with ± 2 standard deviations.

TEN 20-30 YRS MALES FLEXING

X-AXIS ONE DIVISION=1 Second
Y-AXIS ONE DIVISION=10 Degrees

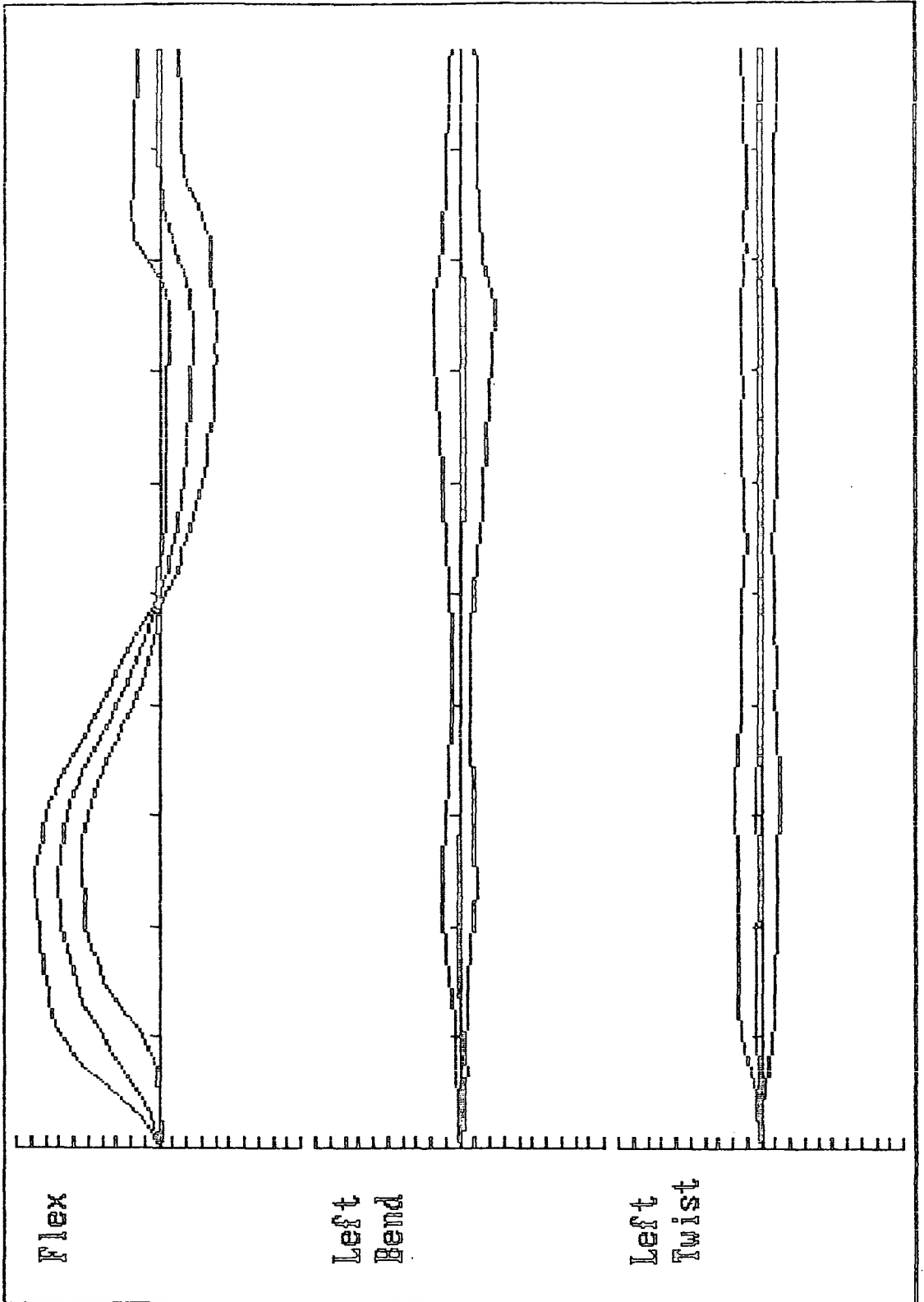

TEN 20-30 yr MALES BENDING TO THE LEFT

X-AXIS ONE DIVISION=1 Second

Y-AXIS ONE DIVISION=5 Degrees

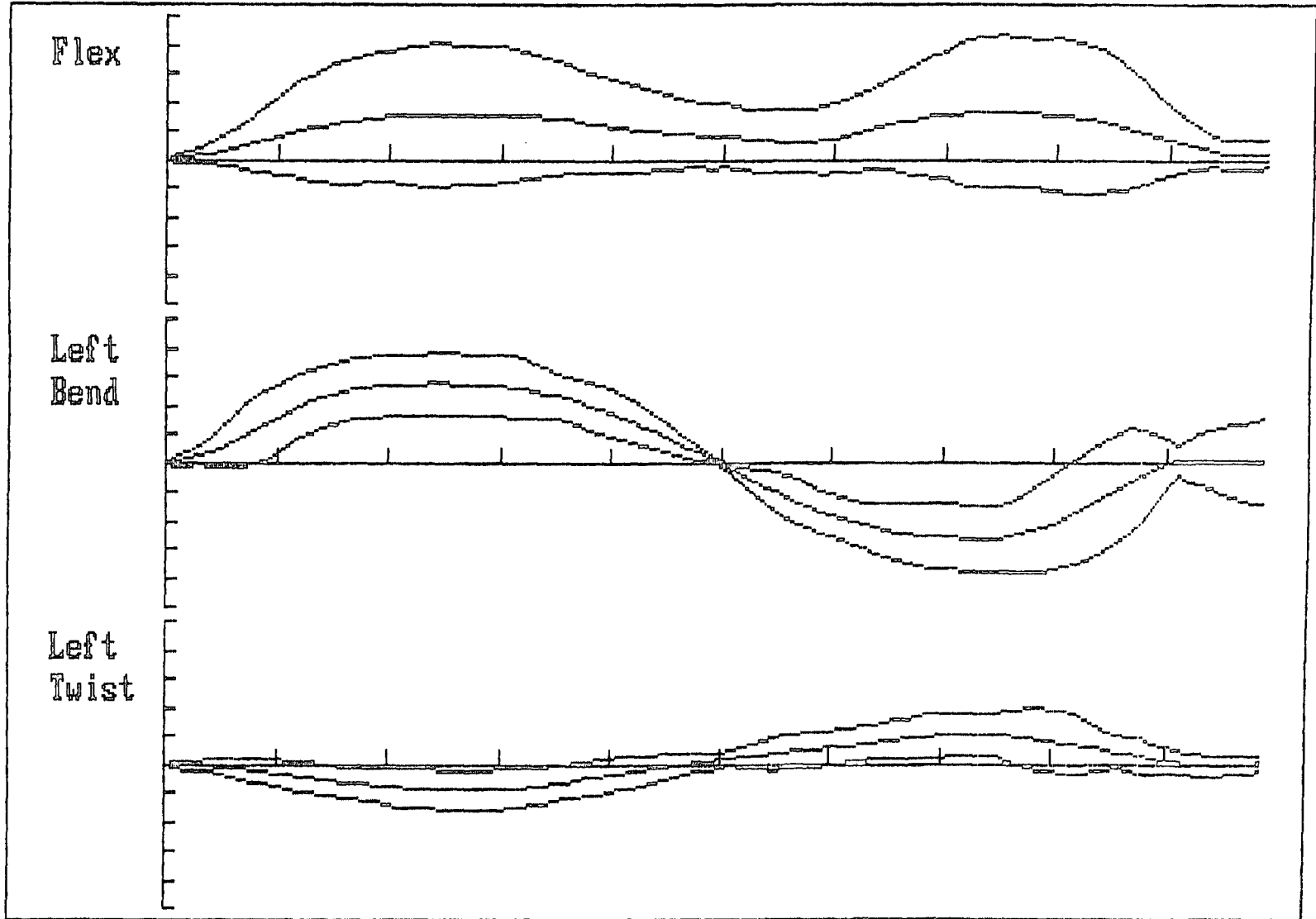

TEN 20-30 yr MALES TWISTING TO THE LEFT

X-AXIS ONE DIVISION=1 Second

Y-AXIS ONE DIVISION=5 Degrees

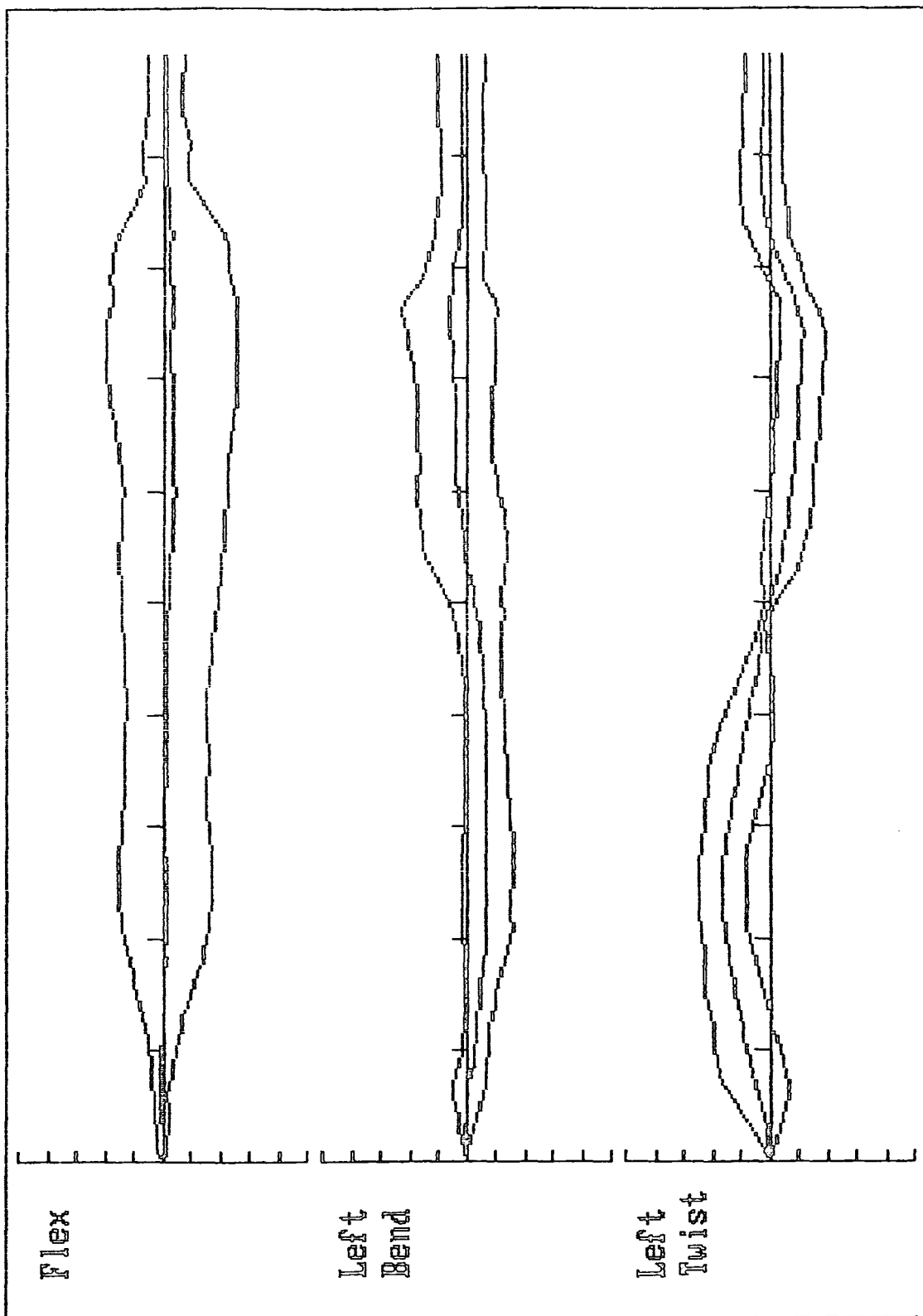

TEN 20-30 YRS FEMALES FLEXING

X-AXIS ONE DIVISION=1 Second
Y-AXIS ONE DIVISION=10 Degrees

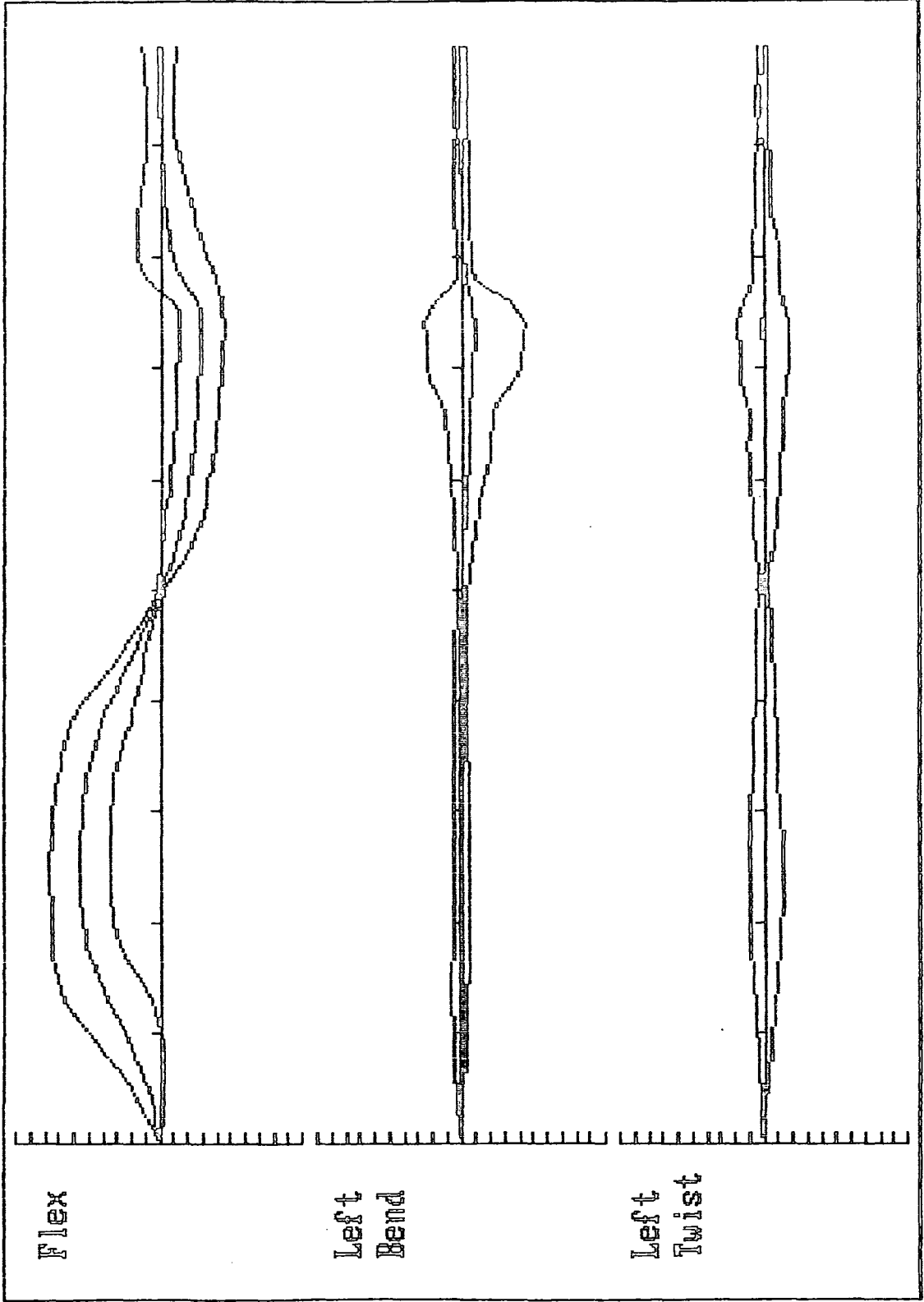

TEN 20-30 YRS FEMALES BENDING TO LEFT

X-AXIS ONE DIVISION=1 Second

Y-AXIS ONE DIVISION=5 Degrees

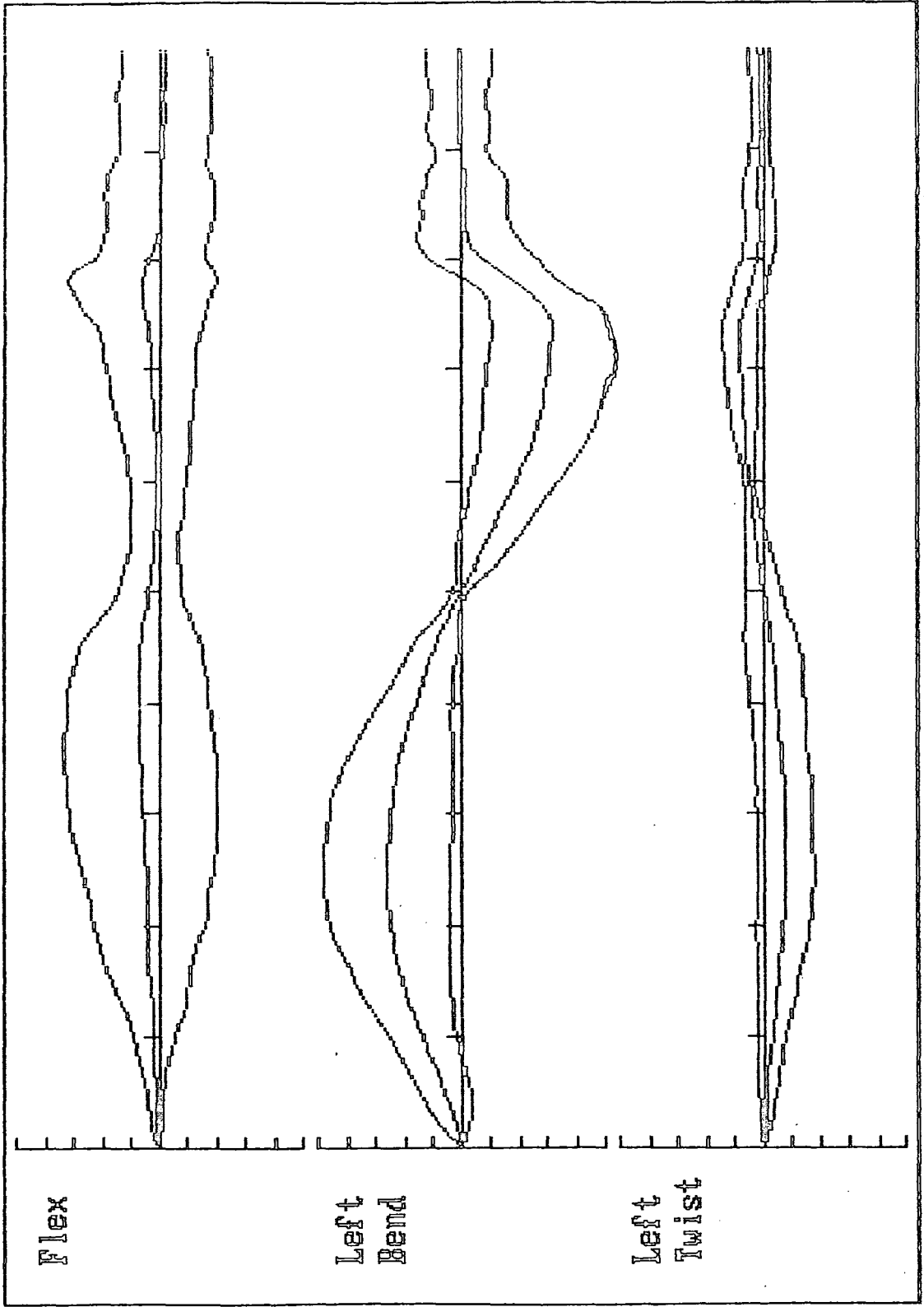

TEN 20-30 yr FEMALES TWISTING TO THE LEFT

X-AXIS ONE DIVISION=1 Second

Y-AXIS ONE DIVISION=5 Degrees

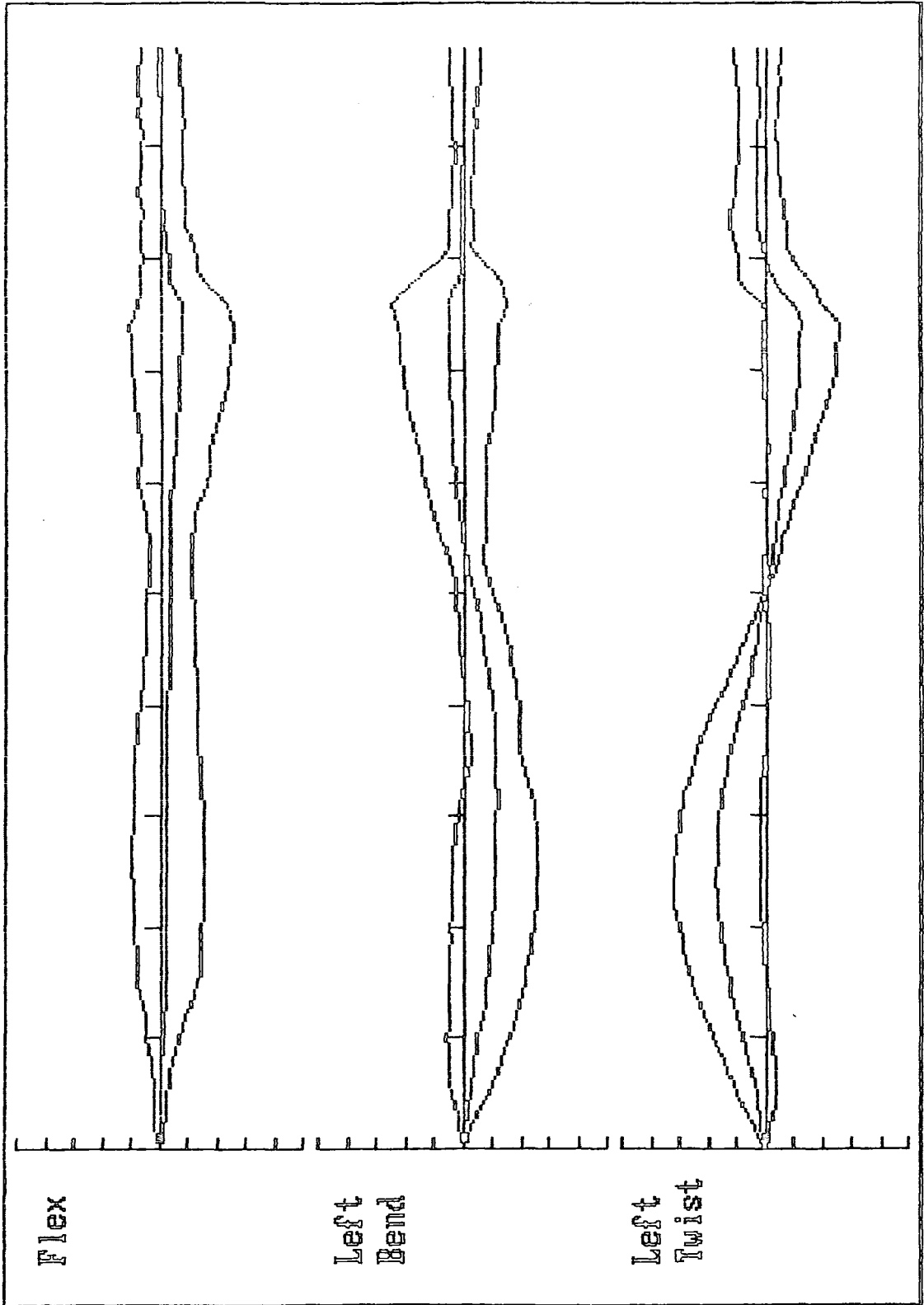

TEN 30-40 yr MALES FLEXING

X-AXIS ONE DIVISION=1 Second
Y-AXIS ONE DIVISION=10 Degrees

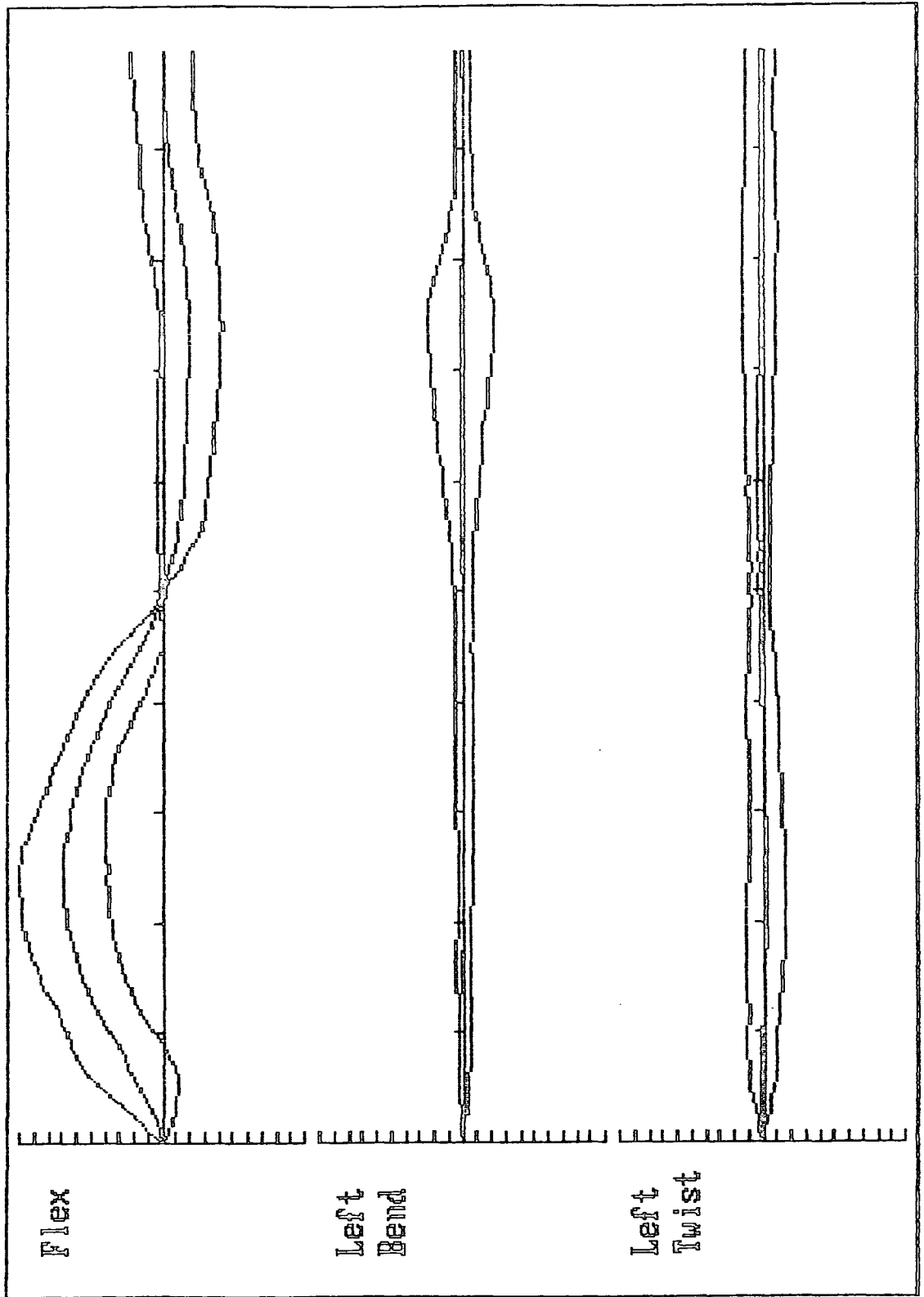

TEN 30-40 yr MALES BENDING TO THE LEFT

X-AXIS ONE DIVISION=1 Second

Y-AXIS ONE DIVISION=5 Degrees

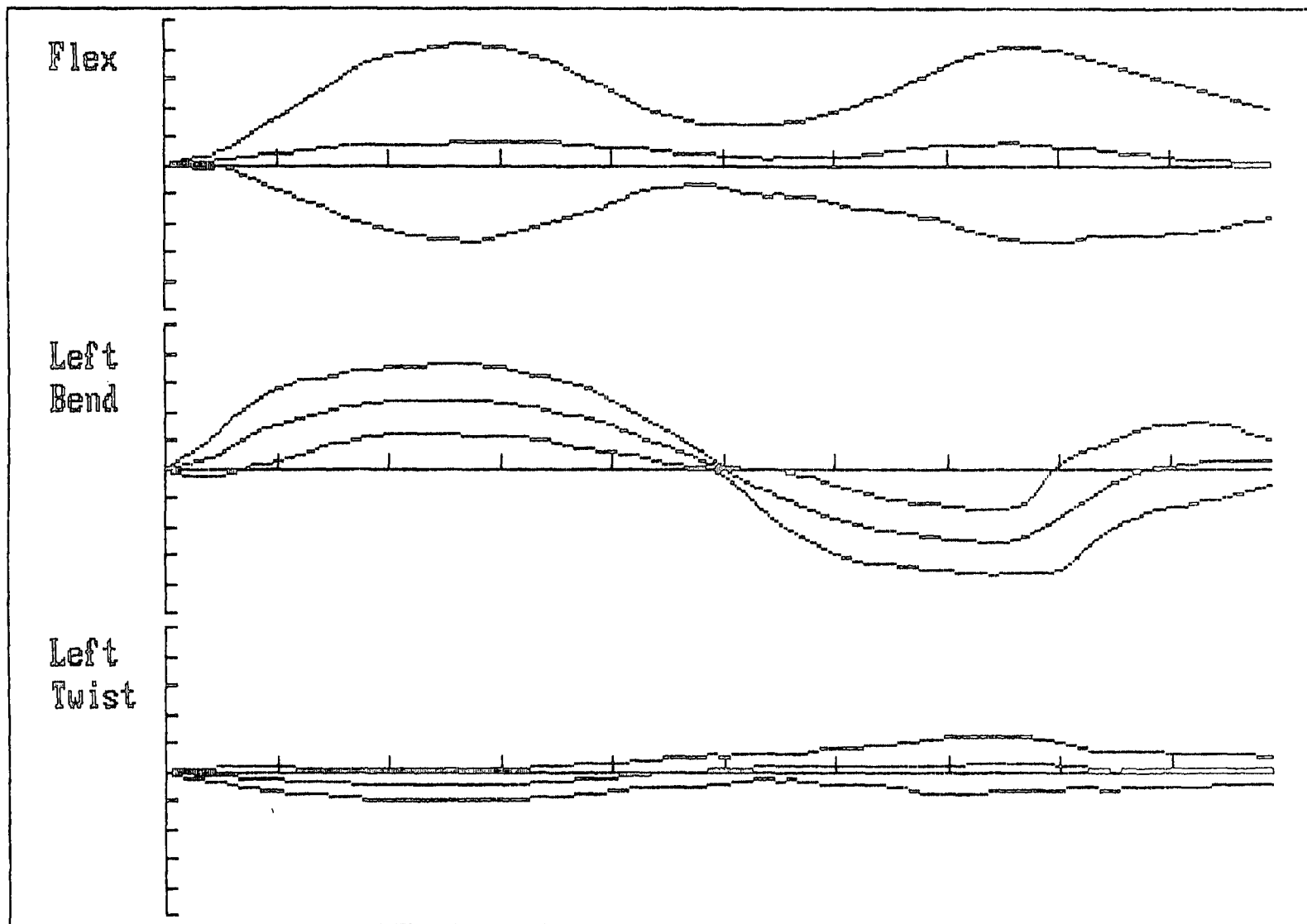

TEN 30-40 yr MALES TWISTING TO THE LEFT

X-AXIS ONE DIVISION=1 Second

Y-AXIS ONE DIVISION=5 Degrees

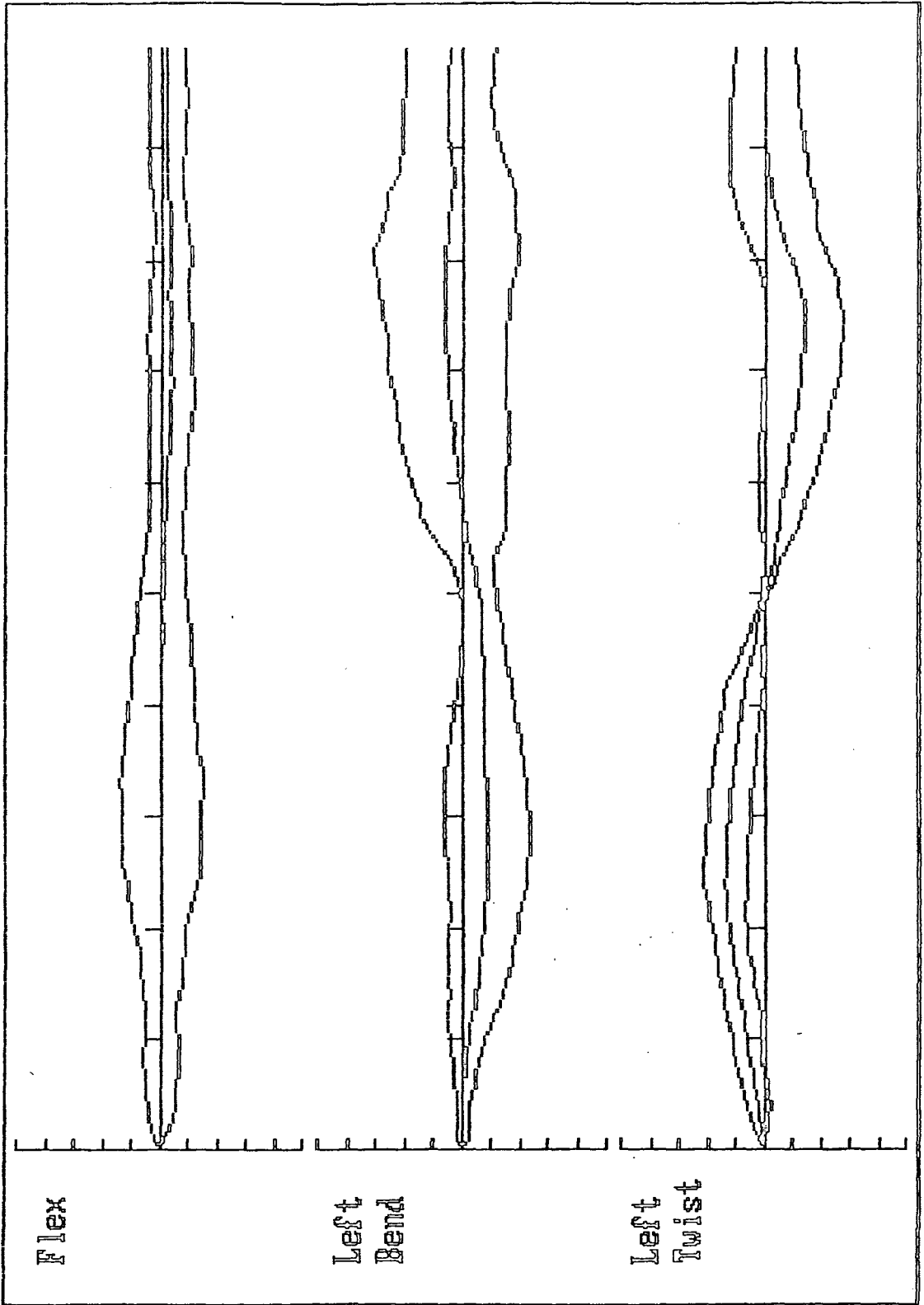

TEN 30-40 yr FEMALES FLEXING

X-AXIS ONE DIVISION=1 Second
Y-AXIS ONE DIVISION=10 Degrees

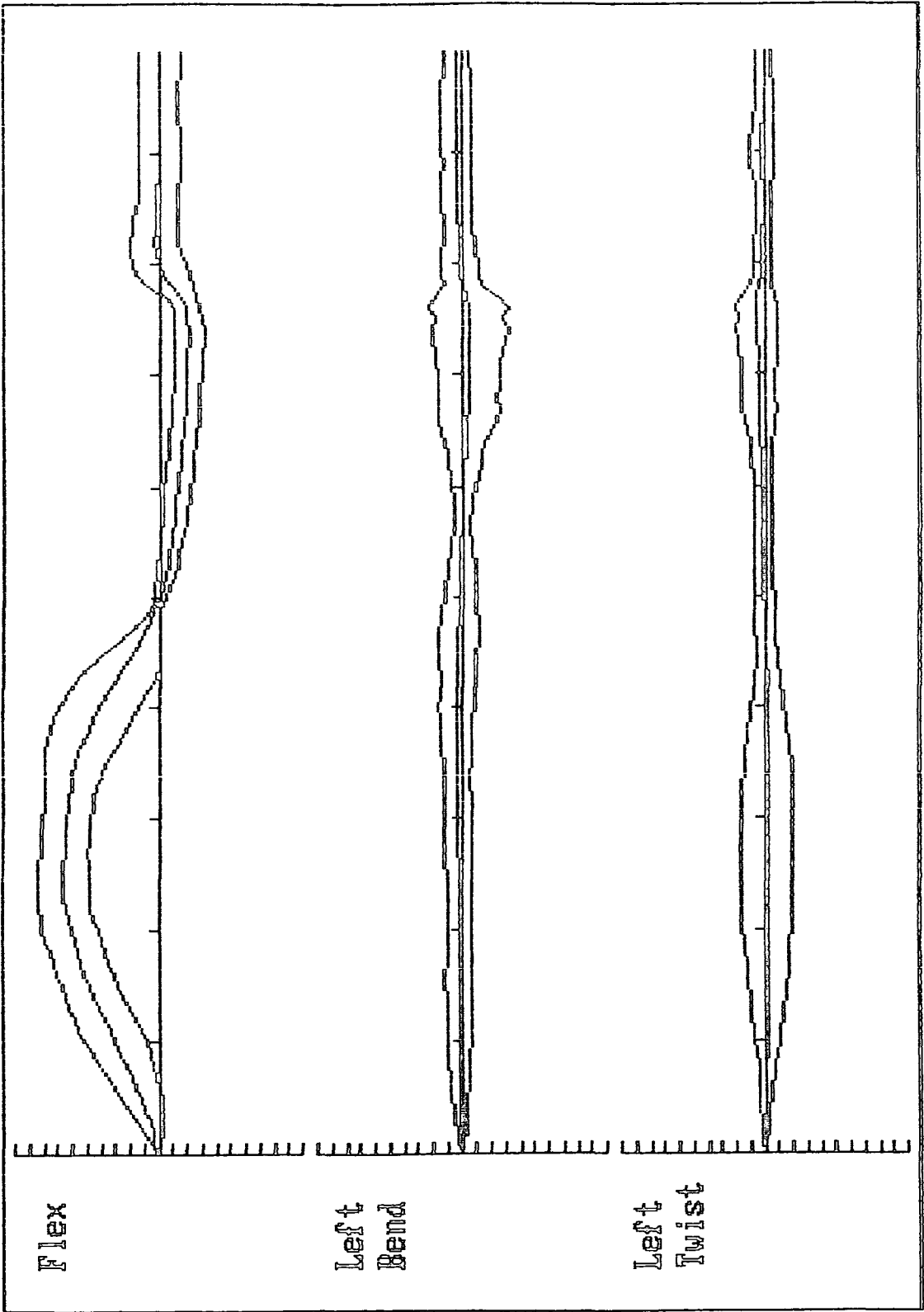

TEN 30-40 yr FEMALES BENDING TO THE LEFT

X-AXIS ONE DIVISION=1 Second

Y-AXIS ONE DIVISION=5 Degrees

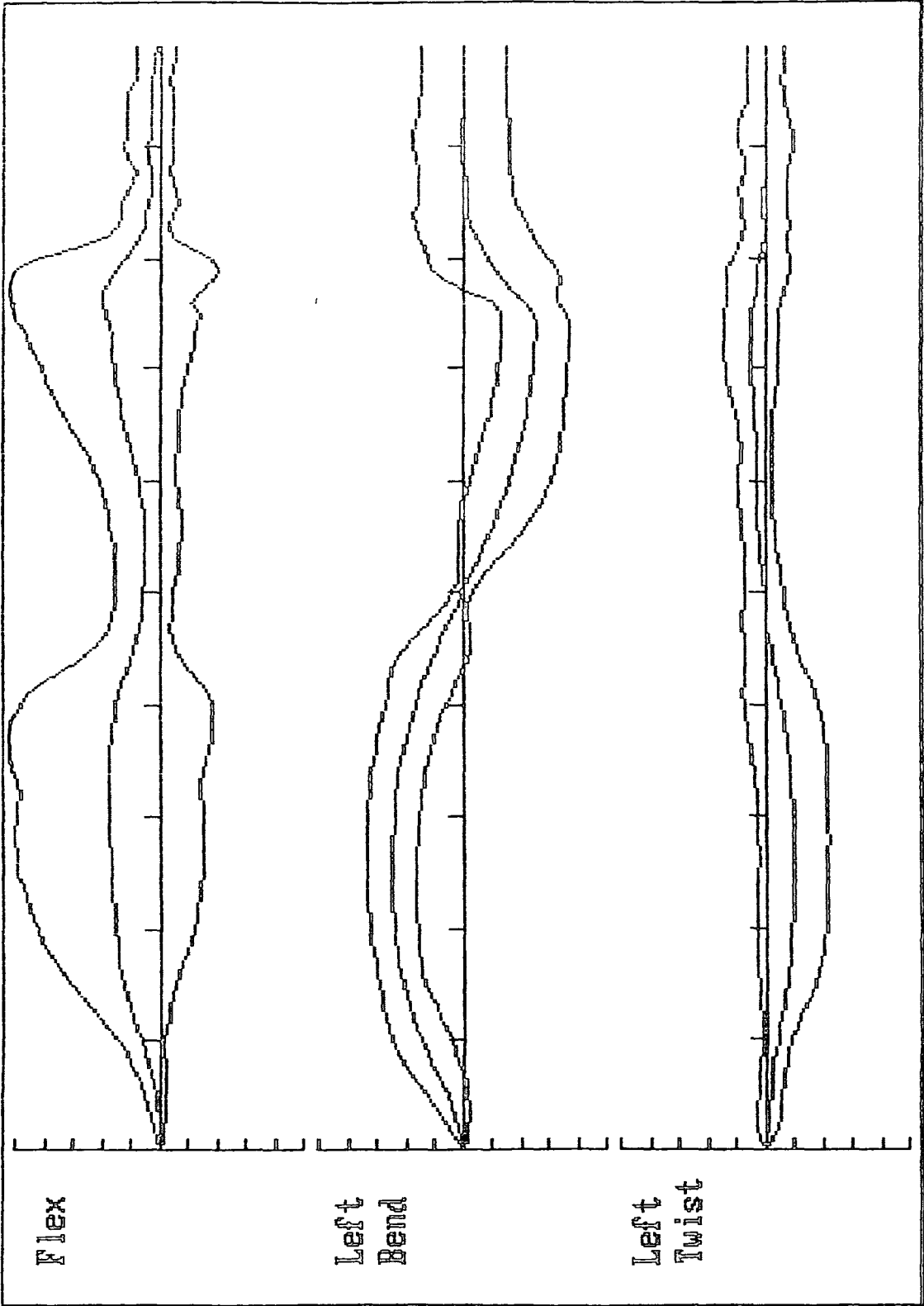

TEN 30-40 yr FEMALES TWISTING TO THE LEFT

X-AXIS ONE DIVISION=1 Second

Y-AXIS ONE DIVISION=5 Degrees

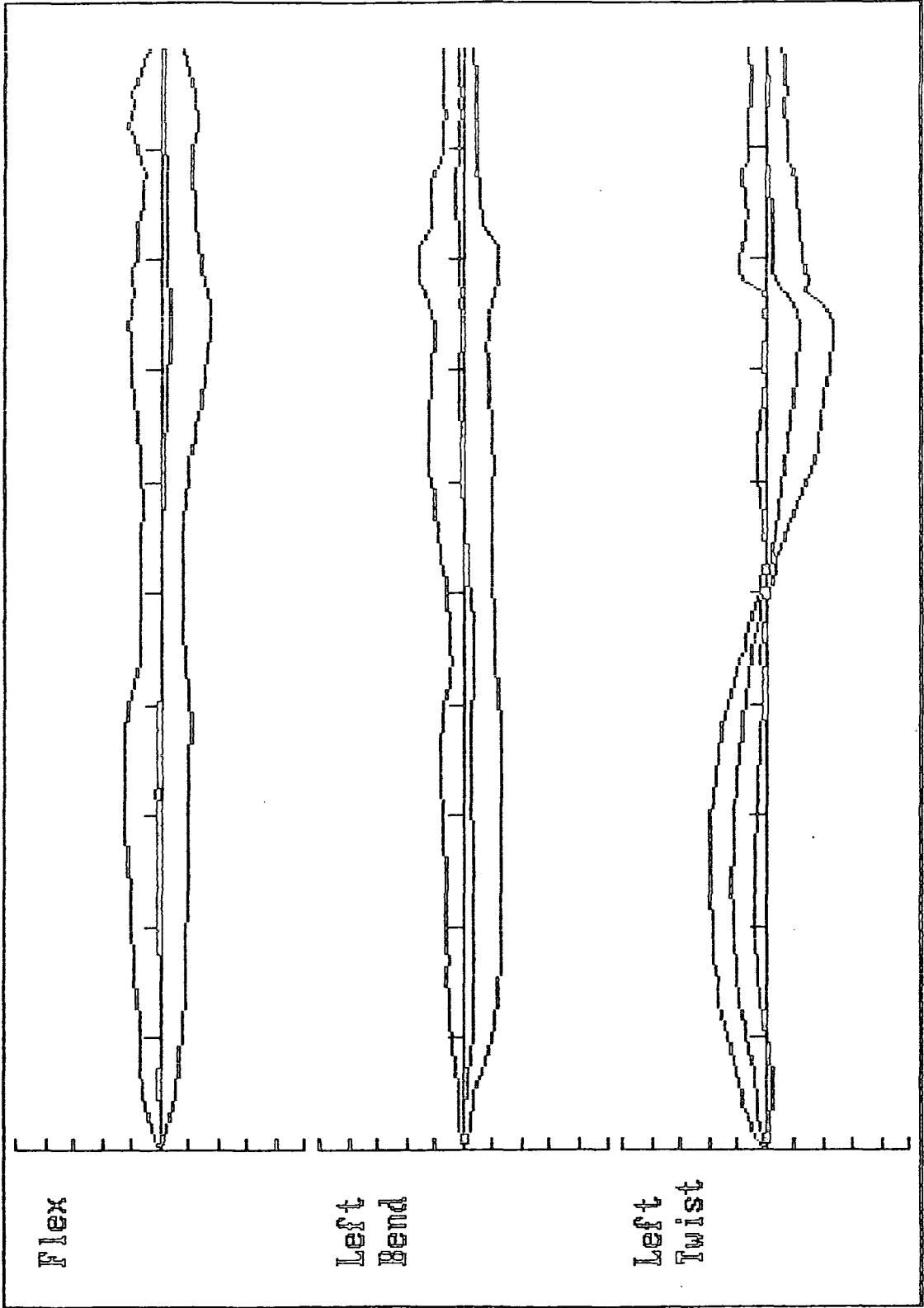

TEN 40-50 yr MALES FLEXING

X-AXIS ONE DIVISION=1 Second
Y-AXIS ONE DIVISION=10 Degrees

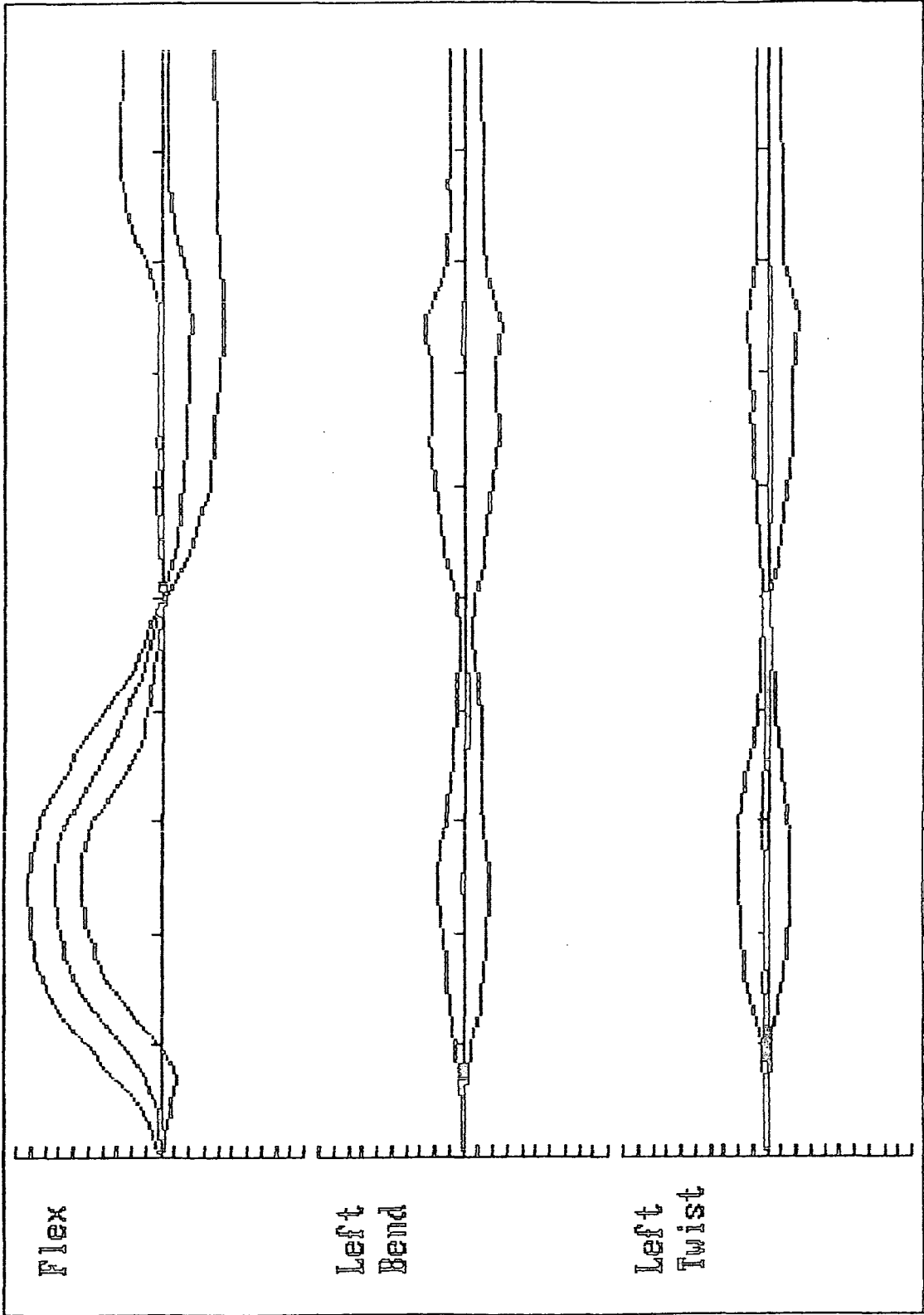

TEN 40-50 yr MALES BENDING TO THE LEFT

X-AXIS ONE DIVISION=1 Second

Y-AXIS ONE DIVISION=5 Degrees

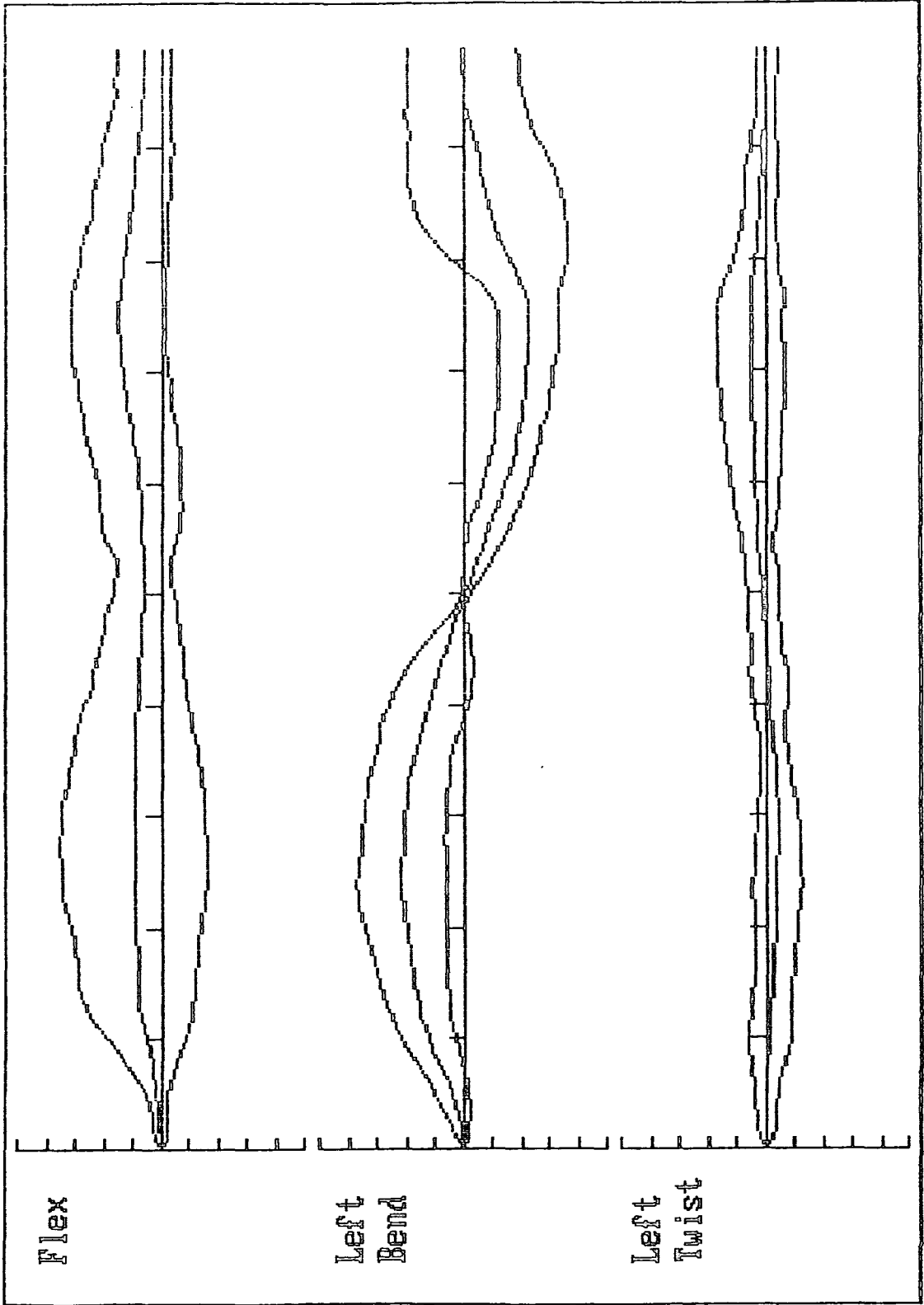

TEN 40-50 yr MALES TWISTING TO THE LEFT
 X-AXIS ONE DIVISION=1 Second
 Y-AXIS ONE DIVISION=5 Degrees

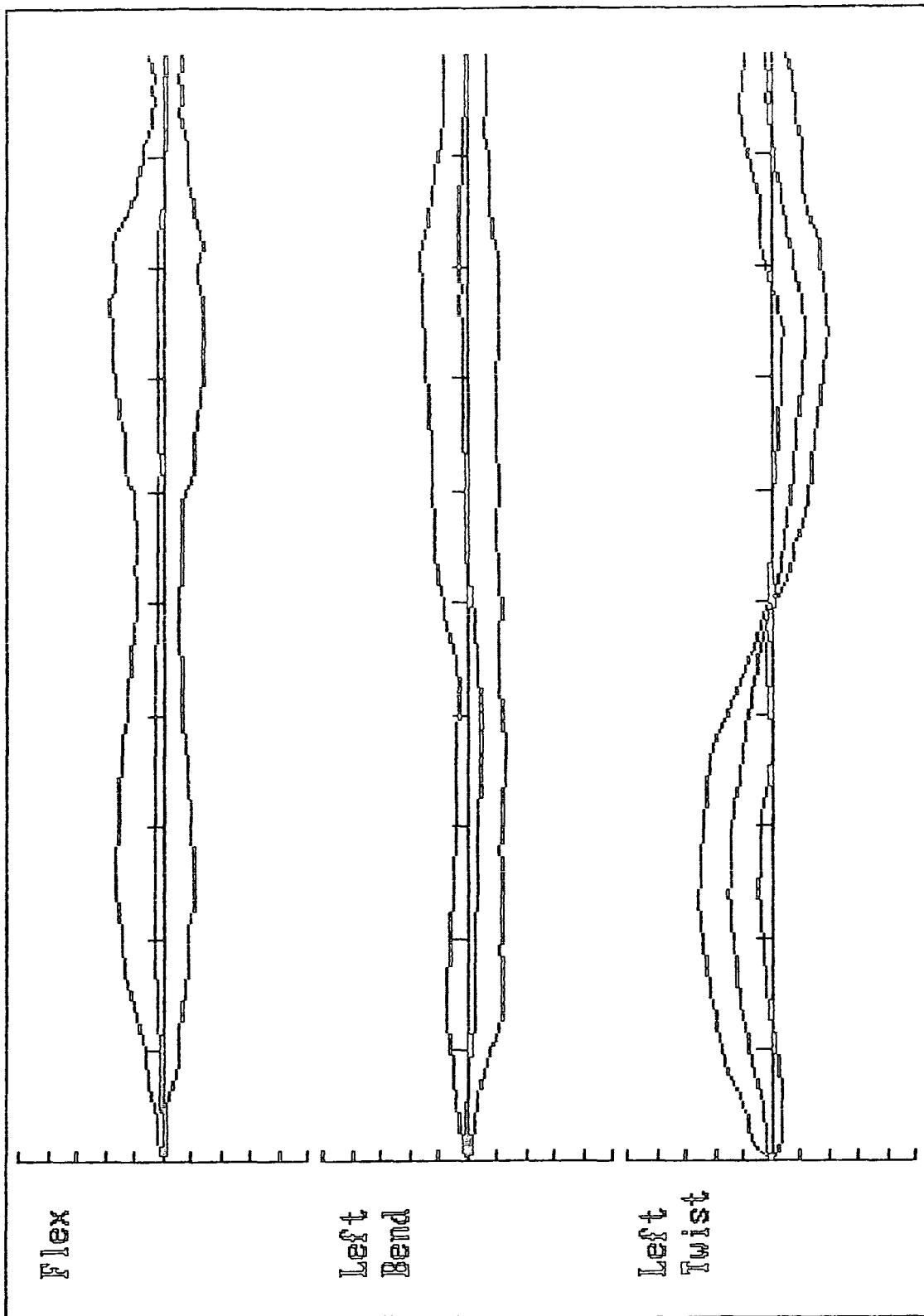

TEN 40-50 yr FEMALES FLEXING

X-AXIS ONE DIVISION=1 Second
Y-AXIS ONE DIVISION=10 Degrees

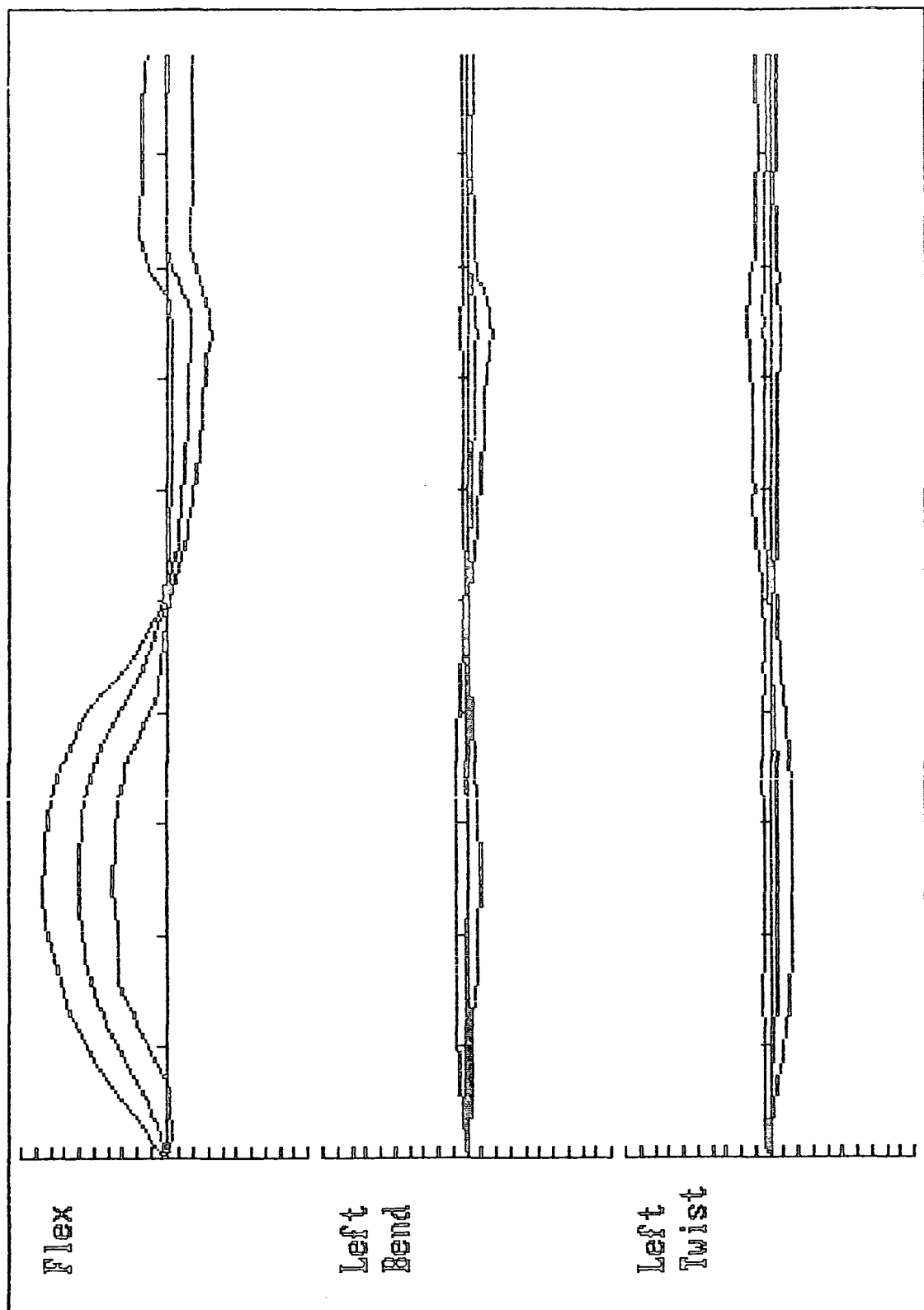

TEN 40-50 yr FEMALES BENDING TO THE LEFT

X-AXIS ONE DIVISION=1 Second

Y-AXIS ONE DIVISION=5 Degrees

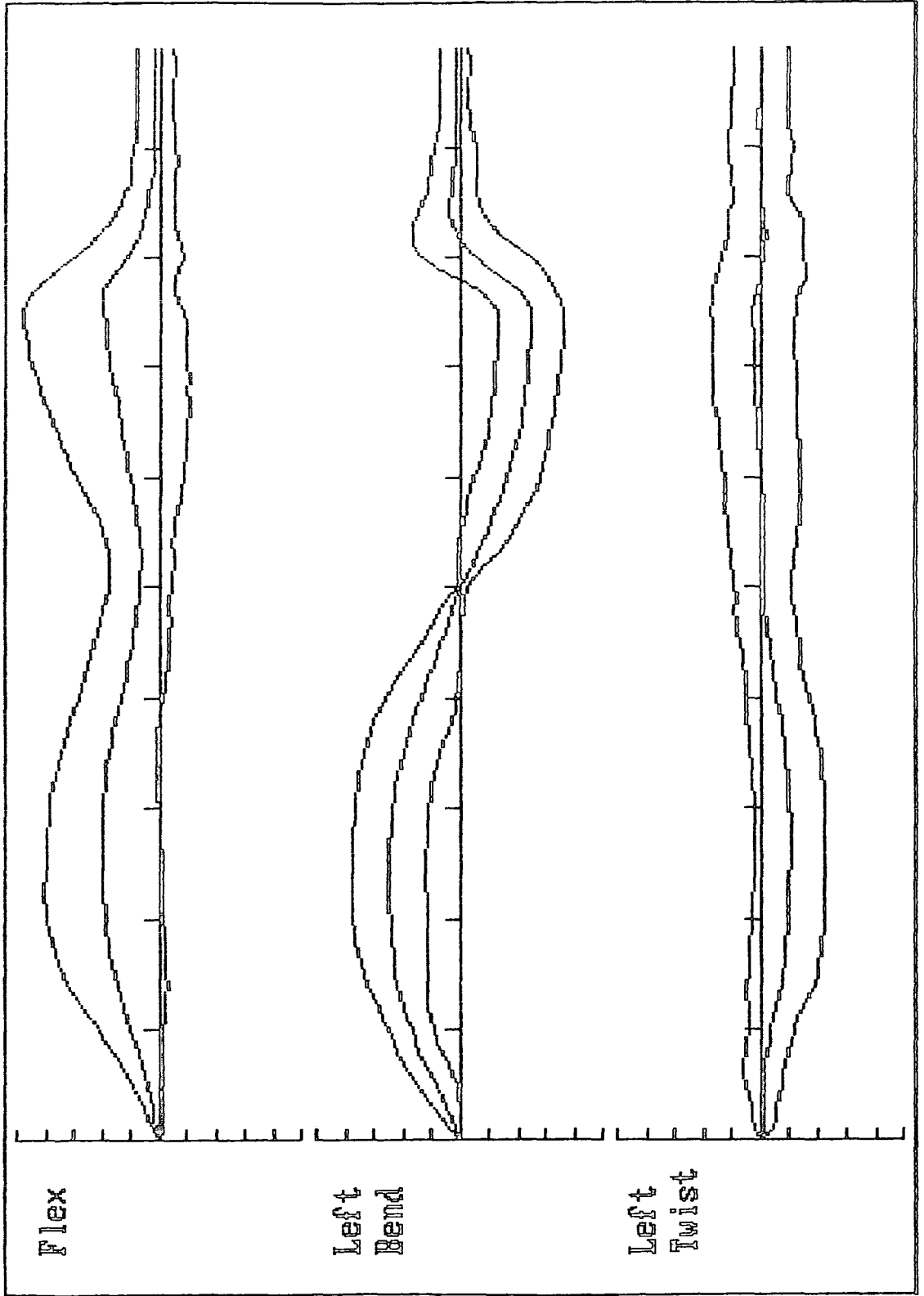

TEN 40-50 yr FEMALES TWISTING TO THE LEFT

X-AXIS ONE DIVISION=1 Second

Y-AXIS ONE DIVISION=5 Degrees

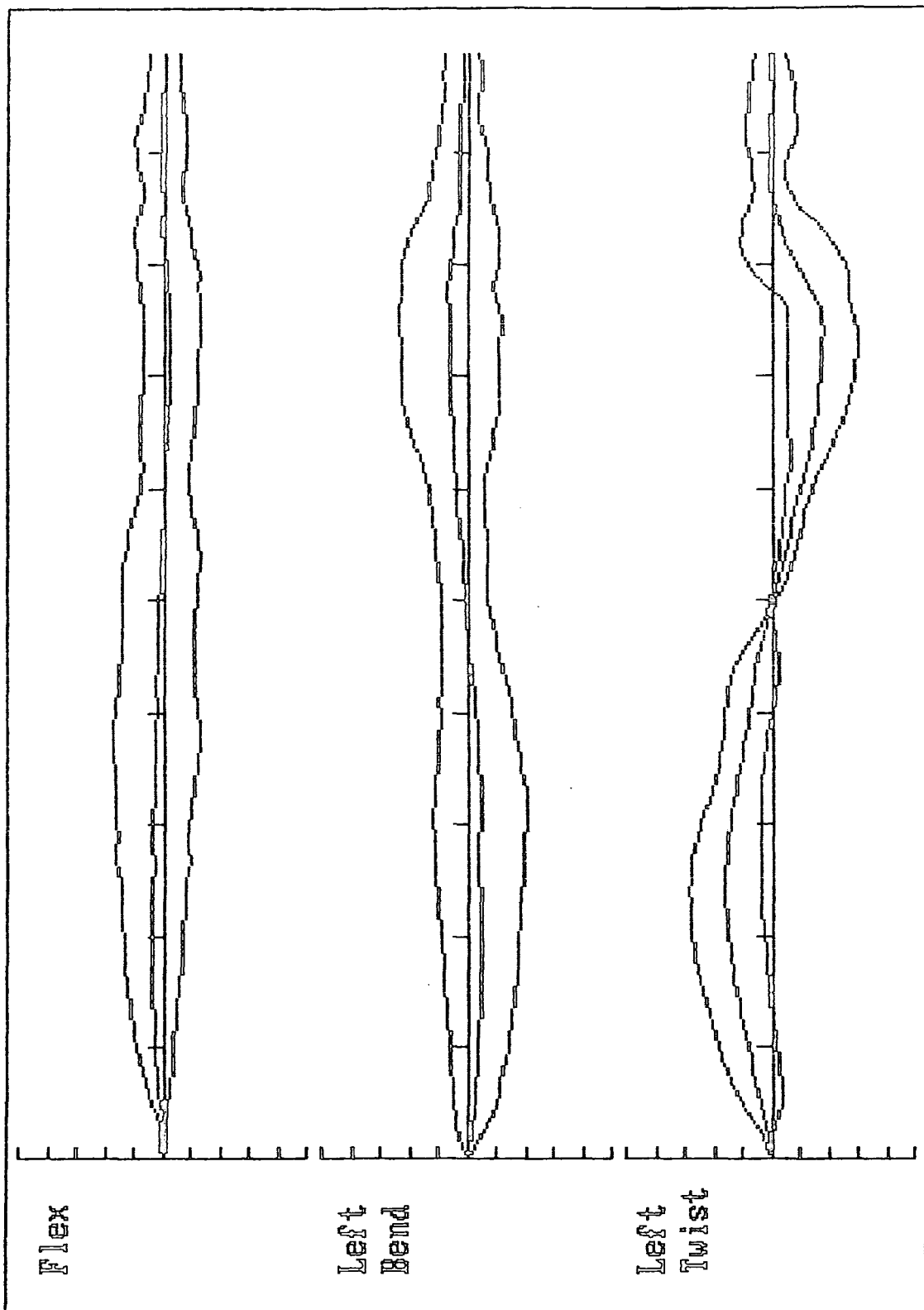

TEN 50+ MALES FLEXING

X-AXIS ONE DIVISION=1 Second
Y-AXIS ONE DIVISION=10 Degrees

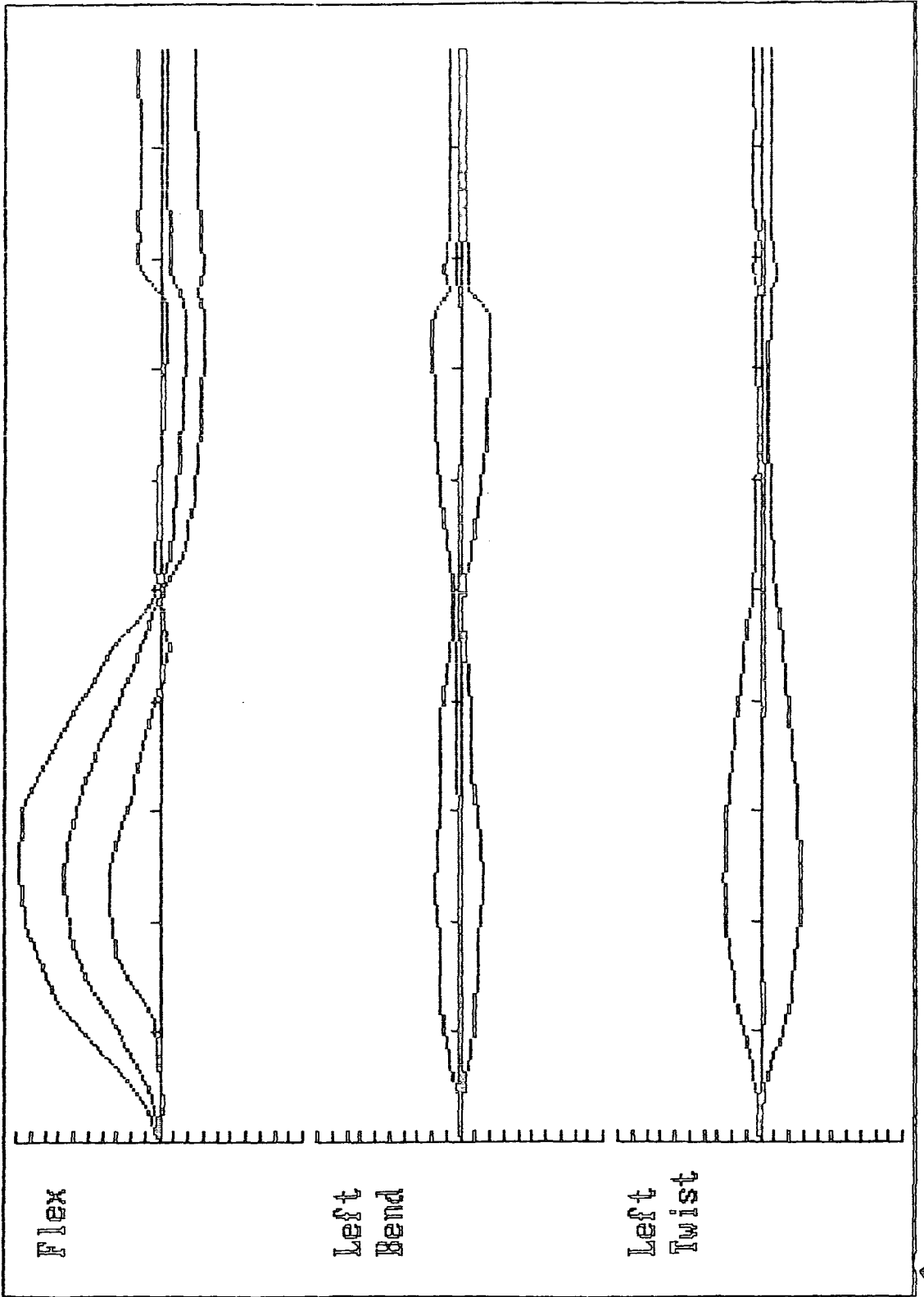

TEN 50+ MALES BENDING TO THE LEFT

X-AXIS ONE DIVISION=1 Second

Y-AXIS ONE DIVISION=5 Degrees

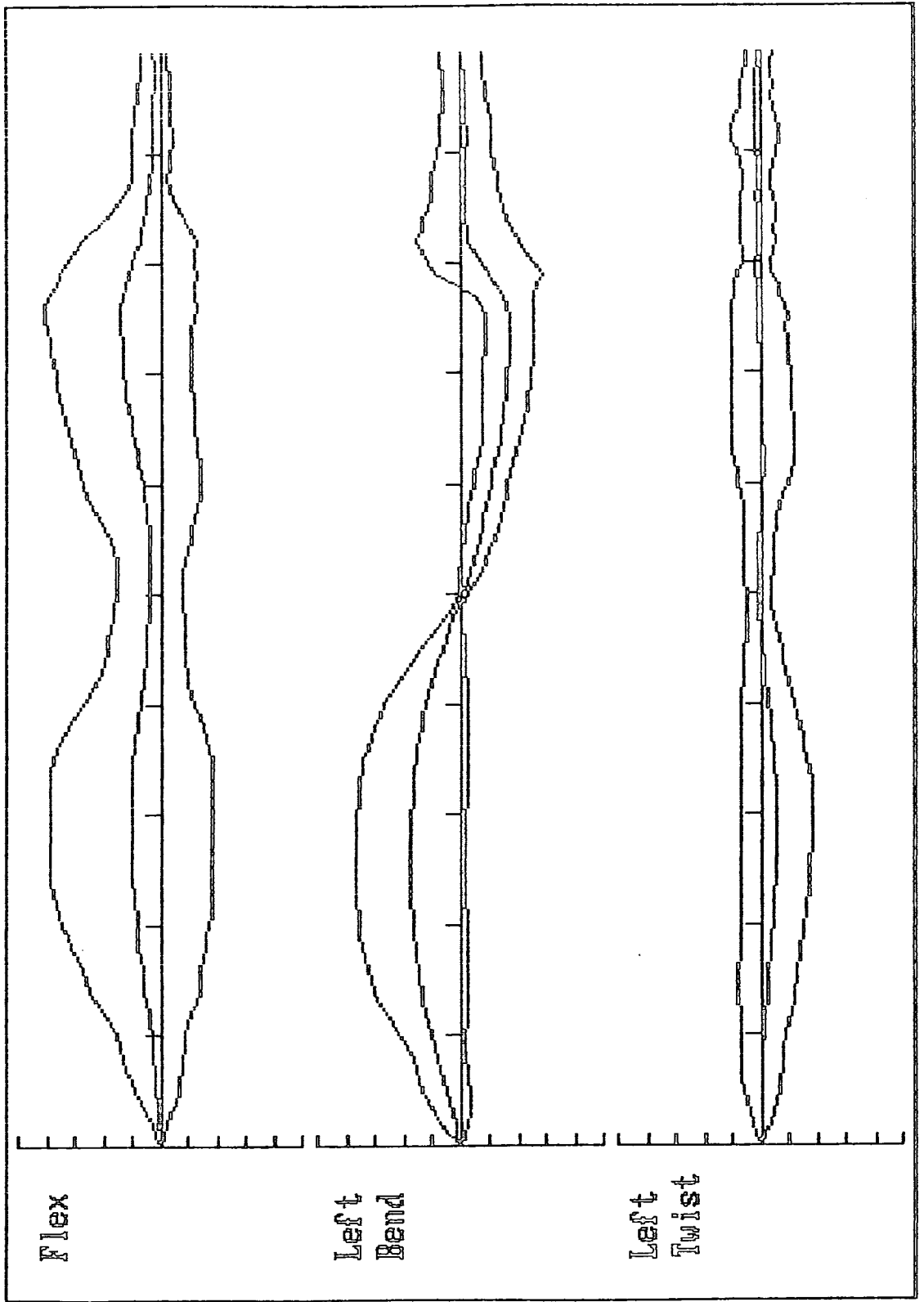

TEN 50+ MALES TWISTING TO THE LEFT

X-AXIS ONE DIVISION=1 Second

Y-AXIS ONE DIVISION=5 Degrees

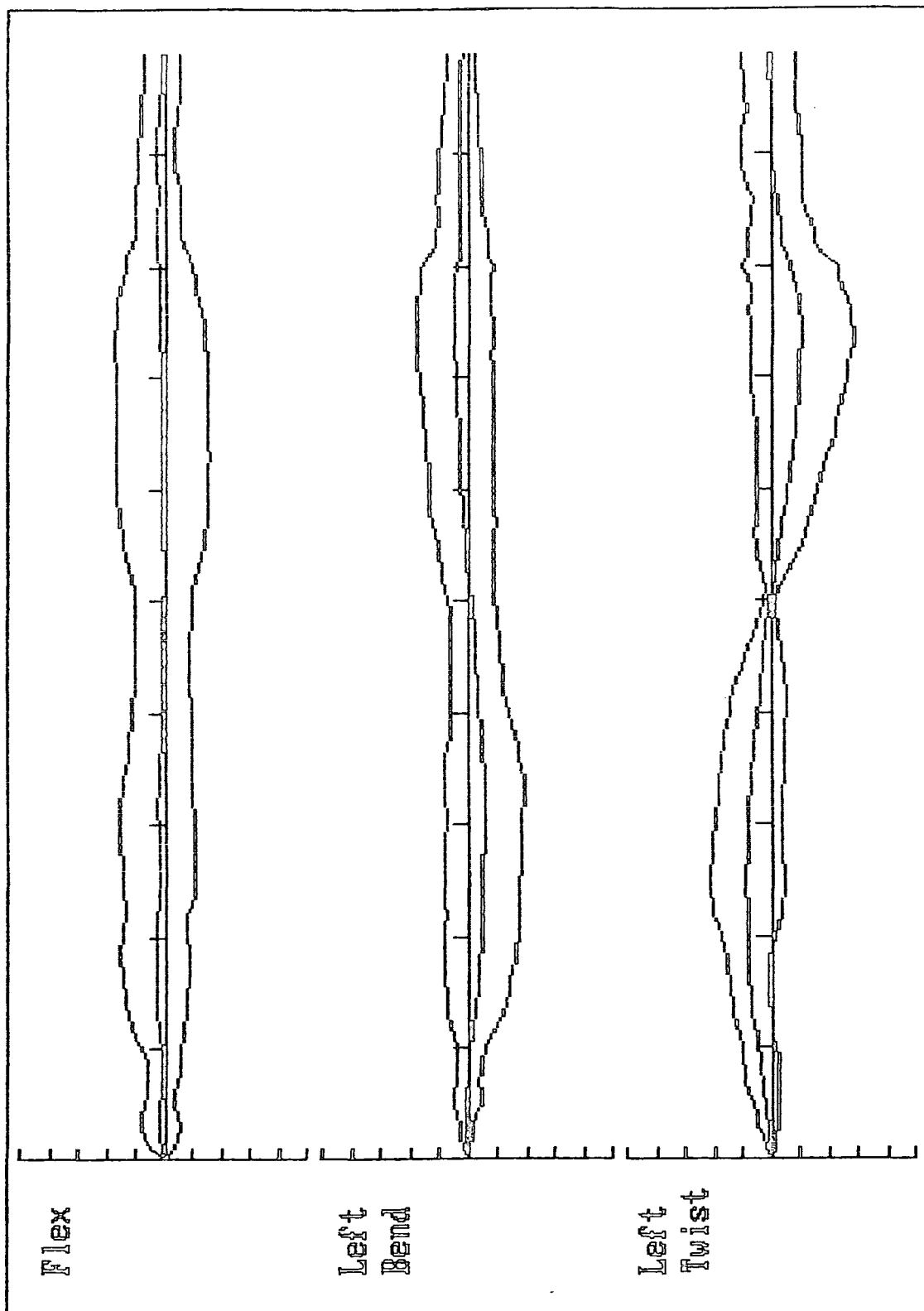

TEN 50+ FEMALES FLEXING

X-AXIS ONE DIVISION=1 Second
Y-AXIS ONE DIVISION=10 Degrees

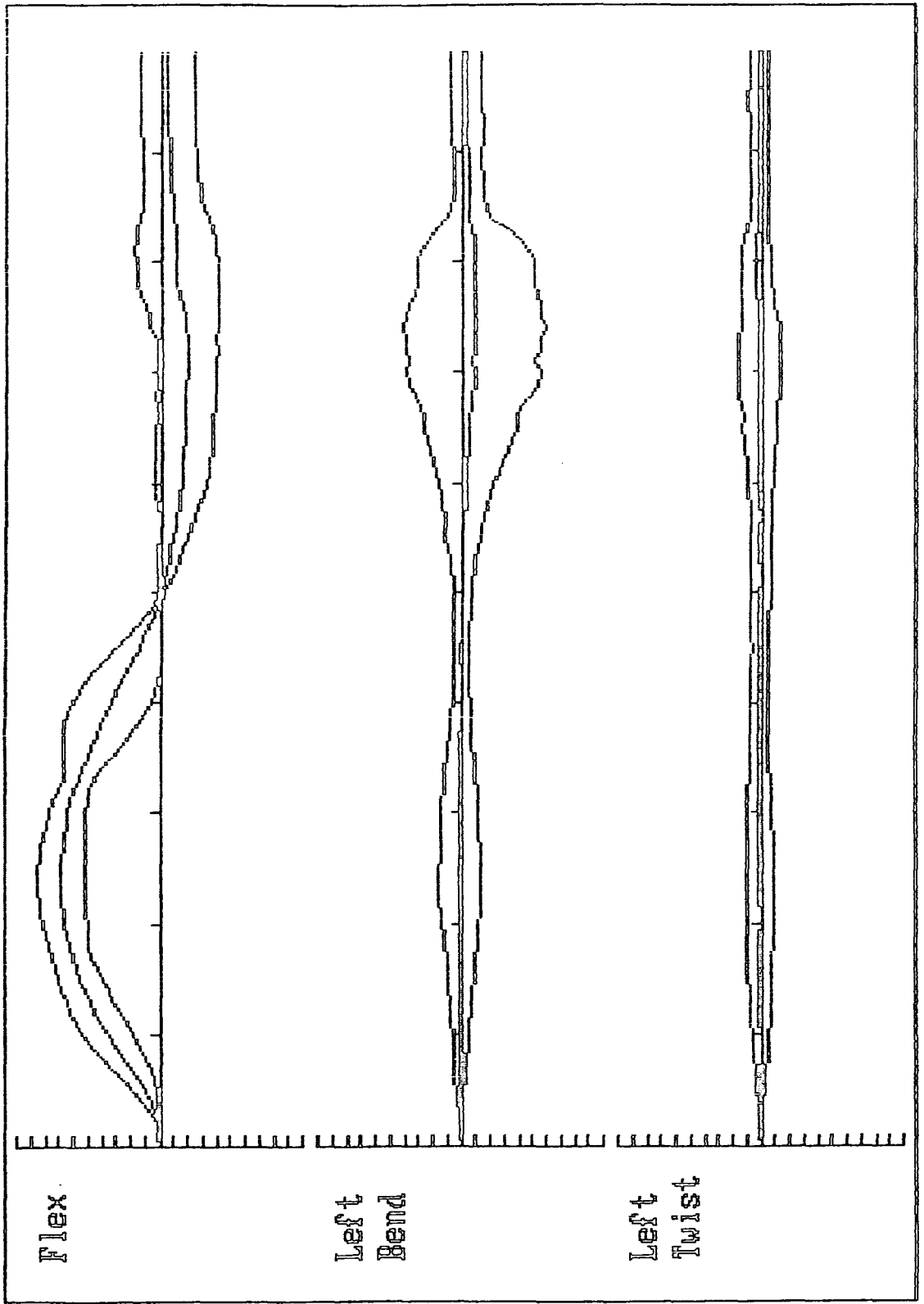

TEN 50+ FEMALES BENDING TO THE LEFT

X-AXIS ONE DIVISION=1 Second
Y-AXIS ONE DIVISION=5 Degrees

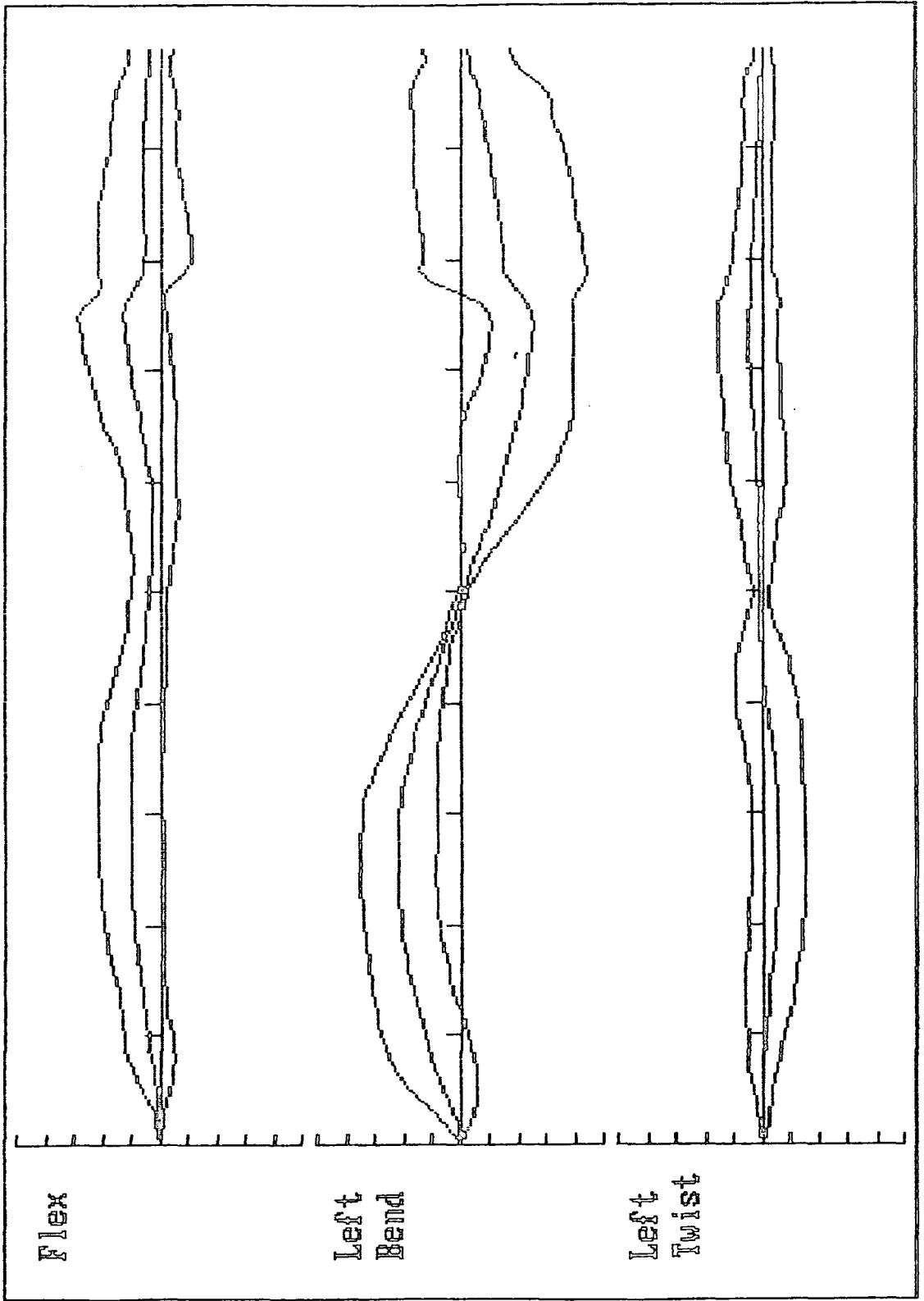

TEN 50+ FEMALES TWISTING TO THE LEFT

X-AXIS ONE DIVISION=1 Second

Y-AXIS ONE DIVISION=5 Degrees

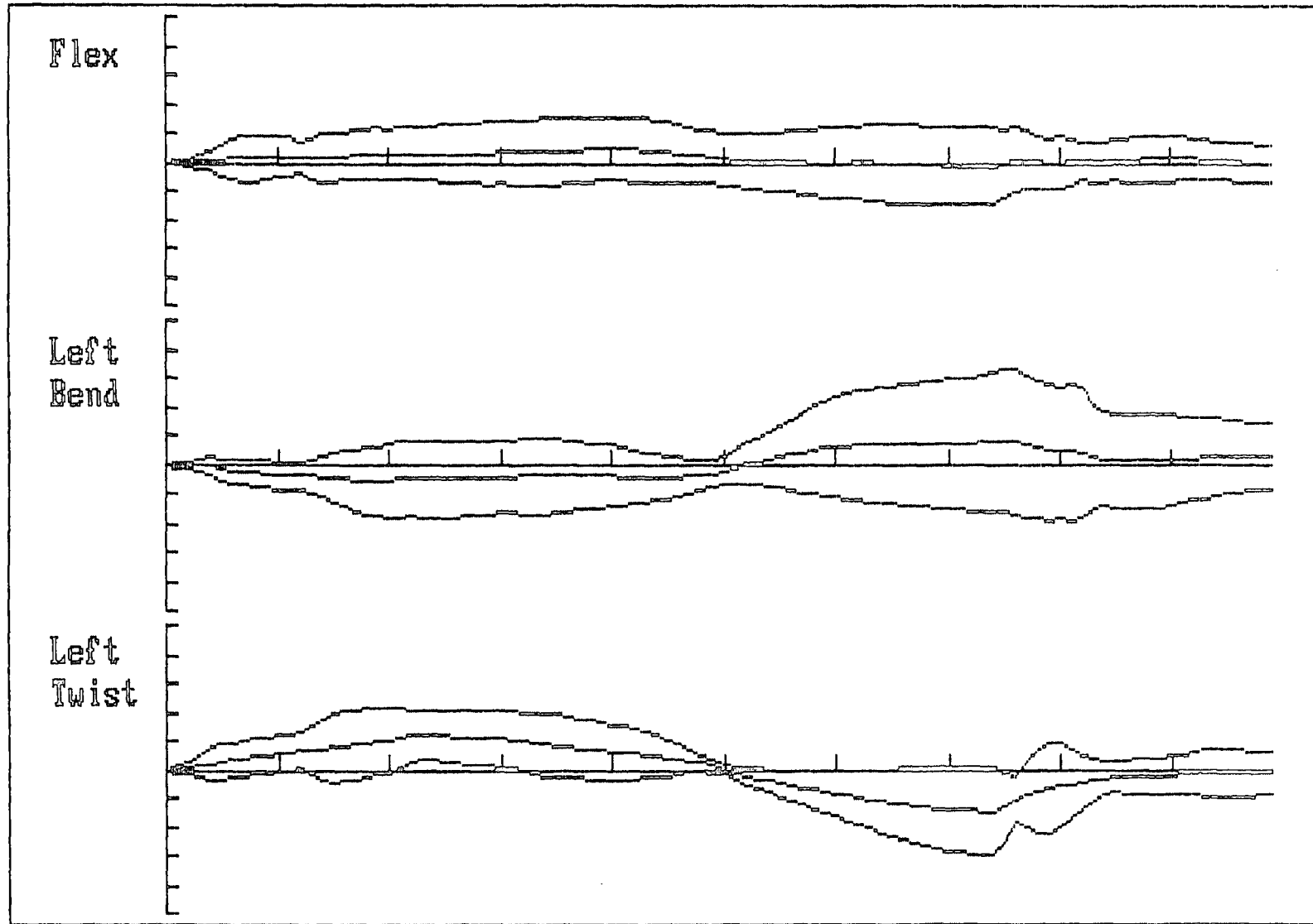

Appendix D

Patient Clinical Assessment Forms

This appendix contains an example of the two forms completed for each patient measured at North Tees and Sunderland General Hospitals respectively.

NAME:

HOSPITAL NO:

AGE:

SEX:

TRAUMA: Yes/No

MECHANICAL BACK PAIN:

Duration of symptoms

Previous surgery - details

disc

posterior element

Intervertebral disc degeneration

Facet arthropathy

R. L. B.

Unstable posterior element (spondylolysis)

R. L. B.

Radicular PAIN:

R. L. B.

Distal PAIN:

R. L. B.

Signs of nerve root tension

R. L. B.

Signs of compression

R. L. B.

MUSCLE SPASM:

LOCAL TENDERNESS:

5/S1 4/5 3/4

MOTION:

Forward flexion

Limited + ++ +++

Extension

Limited + ++ +++

Lateral flexion

Limited + ++ +++

Rotation

Limited + ++ +++

PAST HISTORY OF CORSET:

INVESTIGATIONS:

Main x-ray

CT scan

Myelogram

Facet injections

TYPE OF OPERATION:

Laminectomy

Anterior Fusion

Posterior Fusion - what stabilisation

Posterior element stabilisation

SPINE MOTION SURVEY.

SUNDERLAND
GENERAL HOSPITAL

Pt. No:
Pt. Stats: Name: Hosp. No:
 Age: DOB

HISTORY.

Previous Episodes: Y / N
Mode of Onset: Sudden/Gradual. Industrial Injury: Y / N
Length of history: <1yr / >1 yr.
Previous Surgery: y / n Type of Surgery:
Outcome: Satisfactory: Y / N.

PRESENT CONDITION.

PAIN: Constant: Y / N. Leg < Back > Leg.
Side: L / R Root: L3 L4 L5 S1
Aggravated by: Coughing Y / N Lifting Y / N Bending Y / N
 Standing Y / N Sitting Y / N Lying Y / N
Analgesia: Constant Y / N

EXAMINATION:

Spinal Movement: Lordosis: Flat: Y / N
 Stiffness: Local Y / N Total: Y / N.
 Flexion: Extension:
 R. Flexion: L. Flexion:
 R. Rotation: L. Rotation:

Spasm: R. paraspinal: Y / N Skew → R: Y / N
 L. paraspinal: Y / N Skew → L: Y / N

Tenderness: Midline: L2 L3 L4 L5 S1. General.
 R Paraspinal: L2. L3. L4. L5. S1. General.
 L Paraspinal: L2. L3. L4. L5. S1. General.

SLR: R. leg: < 45° Y / N Tension +ve: Y / N
 L. leg: < 45° Y / N Tension +ve: Y / N

Reflex Change: R. Leg: K. J. Y / N A. J. Y / N
 L. Leg: K. J. Y / N A. J. Y / N
 Plantar response +ve: Y / N

Sensory Change: R. Leg: L2. L3. L4. L5. S1. Nonspecific.
 L. Leg: L2. L3. L4. L5. S1. Nonspecific.

Motor Change: Glutei: Y / N: R / L. Quads: Y / N R / L
 EHL : Y / N: R / L. Evert: Y / N R / L
 Plantar flexors: Y / N: R / L.

Inappropriate 1. 2. 3. 4. 5. %age:
Signs:

SPINE MOTION SURVEY.

Pt. No:

INVESTIGATIONS:

Inflammatory: Y / N

R. A. / A. S.

Plain XR: Normal: Y / N

if N:

Skew: Y / N

O. A. Y / N.

R. Facets: Y / N

L. Facets: Y / N

Lordosis present: Y / N
→R / →L.

L1. L2. L3. L4. L5. S1.

L1. L2. L3. L4. L5. S1.

L1. L2. L3. L4. L5. S1.

Myelogram: Y / N

if N:

Level: R: L3/4. L4/5. L5/S1/

Level: L: L3/4. L4/5. L5/S1/

Normal: Y / N.

Disc Y / N. Lat. recess: Y / N.

C. T.: Y / N

if N:

Level: R: L3/4. L4/5. L5/S1/

Level: L: L3/4. L4/5. L5/S1/

Normal: Y / N.

Disc Y / N. Lat. recess: Y / N.

Diagnosis: Normal: Y / N.

if Y: F. O. : Y / N

if N: Disc Y / N. Lat. recess: Y / N.

Level: R: L3/4. L4/5. L5/S1/

Level: L: L3/4. L4/5. L5/S1/

Proposed Surgery: Discectomy Y / N

Laminectomy Y / N

Lam + Disc Y / N

Fusion Y / N

Fusion + Ex Y / N

Surgery: Y / N

Date:

Confirmed: Y / N.

if N: Disc Y / N. Lat. recess: Y / N.

Level: R: L3/4. L4/5. L5/S1/

Level: L: L3/4. L4/5. L5/S1/

Outcome: Retest Y / N

Cure: Y / N.

Appendix E

Patient Movement Assessment

Patients movements were assessed and graded according to the methods and definitions given in Chapter 5 and are presented below.

E.1 North Tees Patients

Patient MK showed very restricted flexion and extension with no abnormal coupled movements. Lateral bend was symmetrically restricted with no coupled axial rotation and normal coupled flexion. Left axial rotation was normal but there was no right rotation, there was normal coupled lateral bend on left twist but none on right twist. Flexion on right twist was mobile.

Patient CS showed restricted flexion and very restricted extension, coupled movements were normal. Lateral bend was symmetrically restricted, there was normal left twist on left bend but no twist on right bend, coupled flexion was restricted. Left axial rotation was very restricted and there was no apparent right rotation, there were no coupled movements.

Patient JU was hyper-mobile on flexion with normal extension. All other movements were normal.

Patient DO was slightly restricted on flexion and very restricted on extension with normal coupled movements. Lateral bend was symmetrically restricted with normal coupled axial rotation, extension was displayed on left bend but normal flexion was shown on right. Left axial rotation was hyper-mobile with right normal, coupled lateral bend was symmetrically restricted with normal flexion.

Patient MP showed restricted flexion with normal extension and coupled movements. Left lateral bend was slightly restricted, right bend was normal as were the coupled twist and flexion. Axial rotation was symmetrically very restricted, left bend occurred normally on right twist but also on left twist, extension occurred on right twist.

Patient BO was very restricted on flexion with normal extension. Left lateral bend was mobile but right bend was very restricted, coupled twist on left bend was normal but restricted on right, flexion was normal. Axial rotation was normal with normal coupled left bend on right twist, however left bend was also displayed on left twist, flexion was normal.

Patient JM showed restricted flexion with normal extension and coupled movements. Left lateral bend was restricted with right very restricted, there was normal coupled left twist on right bend but there was also left twist on left bend, coupled flexion was restricted. Axial rotation was symmetrically restricted, coupled lateral bend and flexion were normal.

Patient SM showed very restricted flexion and restricted extension, there were no abnormal coupled movements. Lateral bend was symmetrically restricted, there was no coupled twist on left bend but normal right, flexion was normal. Axial rotation and coupled movements were all normal.

Patient NM showed restricted flexion and very restricted extension, left bend and left twist were displayed during extension. Lateral bend was symmetrically very restricted with correspondingly very restricted coupled movements. Axial rotation was all but non-existent as was any coupled bend, some flexion was displayed while attempting right twist.

Patient JH showed very restricted flexion and normal extension and coupled movements. Lateral bend was normal as was coupled twist, flexion was restricted. Axial rotation was normal but coupled bend to both sides was very restricted, extension was displayed on left twist but normal flexion was apparent on right.

Patient EJ showed normal flexion and extension. Lateral bend was near normal, no coupled twist was shown on left bend but was normal on right bend, flexion was normal. Axial rotation was seen to be symmetrically hyper-mobile with higher than normal coupled bend and flexion.

Patient GG showed normal flexion but very restricted extension. Left lateral bend was normal but right bend was restricted, coupled twist was normal on left bend but restricted on right, flexion was normal. Axial rotation was normal with greater than normal coupled bend and flexion.

Patient AB showed very restricted flexion and restricted extension. Lateral bend was symmetrically very restricted, coupled twist was normal on right bend but left twist was shown on left bend, flexion was restricted on left bend but normal on right. Left axial rotation was slightly restricted and right was very restricted, normal right bend was shown on left twist but no bend was shown on right twist, flexion was normal.

Patient VA showed restricted flexion and extension. Lateral bend was symmetrically restricted, coupled axial rotation was restricted on left bend but normal on right bend, flexion was restricted. Axial rotation was symmetrically restricted, coupled movements were normal.

E.2 Sunderland Patients

Patient JT showed restricted flexion with normal extension. Lateral bend was normal but no coupled twist was present, flexion was restricted on left bend but normal on right. Axial rotation was normal, left bend occurred on left twist and there was no coupled twist on right bend, flexion was normal.

Patient GH showed restricted flexion and near normal extension. Left lateral bend was restricted with right very restricted, coupled movements were normal. Left axial rotation was normal but right was restricted, left bend occurred with left twist and right bend with right twist.

Patient LT showed very restricted flexion with normal extension. Lateral bend and coupled movements were normal. Axial rotation was bilaterally absent with correspondingly restricted coupled movements.

Patient IB had very restricted flexion and extension. Left lateral bend was restricted and right very restricted, coupled axial rotation was symmetrically restricted and flexion was also restricted. No movement in any plane was seen during attempted axial rotation.

Patient ST showed very restricted flexion and normal extension. Left lateral bend was very restricted but right was normal, coupled twist was absent on left bend but was normal on right, flexion was restricted. Axial rotation was

symmetrically restricted, coupled bend was normal, extension occurred on both left and right twist.

Patient CW showed very restricted flexion and no extension. Lateral bend was symmetrically very restricted but coupled twist was normal, flexion was restricted. Axial rotation was symmetrically restricted, coupled bend was restricted, flexion was normal.

Patient MY showed very restricted flexion and normal extension. Lateral bend was symmetrically very restricted, coupled movements were normal. Left axial rotation was normal and right showed slight restriction, coupled movements were again normal.

Patient SG showed very restricted flexion and normal extension. Left lateral bend was restricted but right was normal, there was no coupled twist and flexion was restricted. Left axial rotation was restricted but right was normal, left bend occurred on left twist and right bend on right twist, flexion was normal.

Patient PC Showed very restricted flexion and extension, left bend and right twist occurred on flexion but coupled movements were normal on extension. Left lateral bend was seen to be hyper-mobile but right was restricted, coupled bend was normal on left twist but restricted on right, flexion was restricted. Axial rotation was normal, coupled bend was normal on right twist but restricted on left twist, flexion was normal.

Patient DB had normal flexion and extension. Lateral bend was also normal but left twist occurred on left bend and right twist on right bend, flexion was normal. Left axial rotation was very restricted but right was normal, left bend occurred during the attempted left twist and there was no twist on right twist, flexion was normal.

Patient LF demonstrated restricted flexion and extension. Left lateral bend was very restricted and right restricted, coupled movements were normal. Axial rotation was normal although left bend occurred on left twist and right bend on right twist, extension occurred on right twist.

Patient RW showed very restricted flexion and no extension. Lateral bend

was normal but coupled bend was restricted on left bend and zero on right bend, flexion was normal. Axial rotation was normal but coupled bend was restricted on left twist and right bend occurred on right twist, extension occurred on right twist.

Patient DN had normal flexion and extension but displayed considerable left bend and left twist on flexion. Lateral bend was symmetrically restricted, left twist occurred on left bend and no twist was apparent on right bend, flexion was normal. Axial rotation was symmetrically restricted and coupled bend was to the same side as the twist, flexion was normal.

Patient AA showed restricted flexion and extension. Lateral bend was symmetrically restricted as was coupled twist, flexion was normal. Left axial rotation was very restricted and there was no right twist, coupled bend was, again, to the same side as the attempted twist, flexion was normal.

Patient ET showed normal flexion but zero extension. Lateral bend was symmetrically restricted, coupled movements were normal. Left axial rotation was restricted but right was normal, coupled movements were again normal.

Patient ED showed very restricted flexion but normal extension. Left lateral bend was very restricted but right was normal, left twist occurred on both sides and flexion was restricted. Left axial rotation was restricted and right was normal, coupled bend occurred to the same side as the twist, flexion was again restricted.

Patient TL showed very restricted flexion and extension. Lateral bend was symmetrically restricted and no coupled twist was apparent, flexion was restricted. No left axial rotation occurred and right was very restricted, no coupled movements occurred.

Patient LR showed very restricted flexion and restricted extension. Lateral bend was normal, coupled twist was restricted on left bend but normal on right, flexion was normal. Axial rotation and coupled movements were normal.

Patient AB showed very restricted flexion and normal extension. Lateral bend and coupled movements were normal apart from restricted flexion on left

bend. Axial rotation was normal but coupled bend was restricted on left twist, being normal on right, flexion was restricted on left twist.

Patient PR showed very restricted flexion and extension. Left lateral bend was very restricted and right restricted, coupled twist was normal on left bend but zero on right bend, flexion was normal. Axial rotation and coupled movements were normal.

Appendix F

Patient Movement Plots

X-AXIS ONE DIVISION=1 Second
Y-AXIS ONE DIVISION=10 Degrees

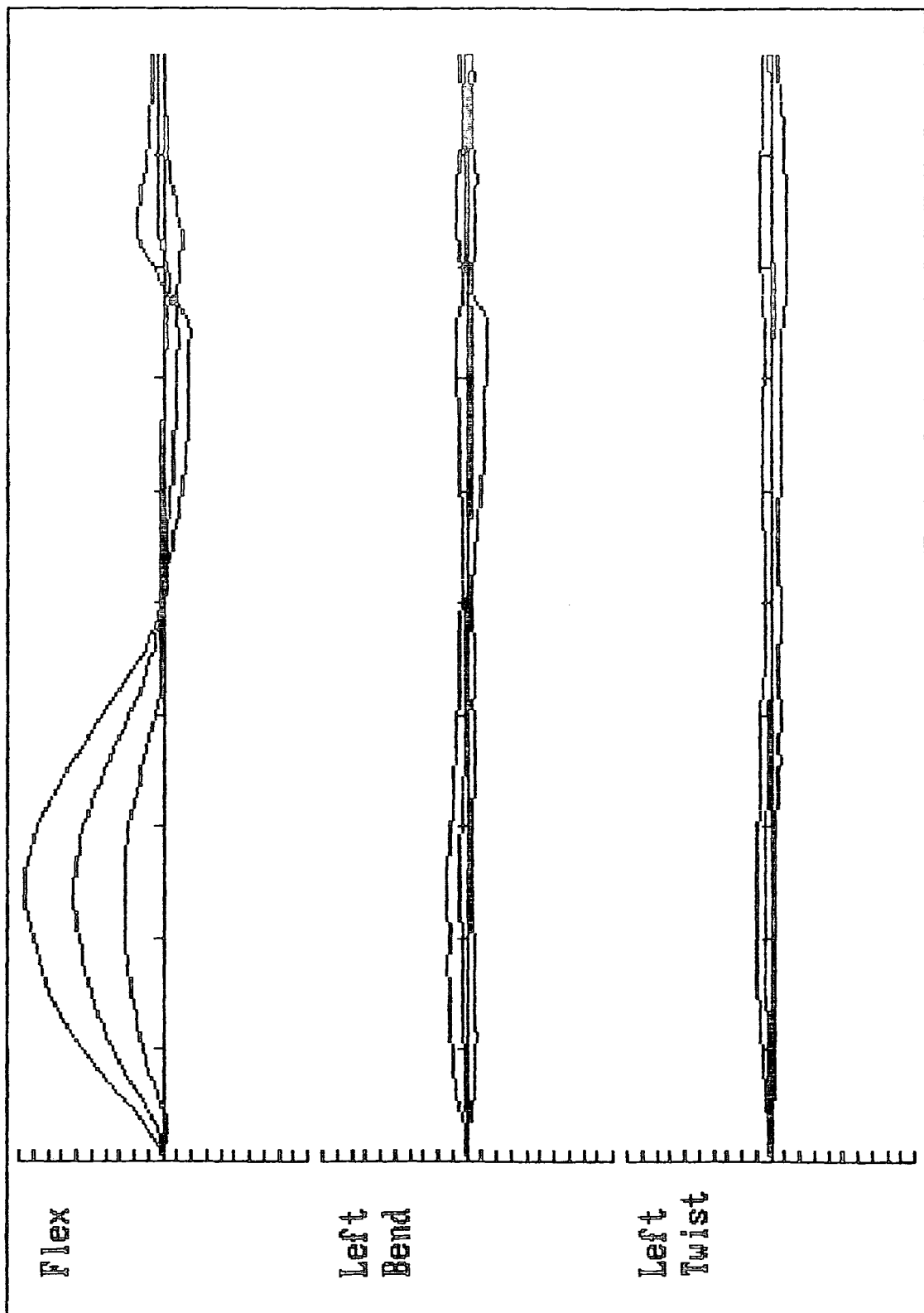

X-AXIS ONE DIVISION=1 Second
Y-AXIS ONE DIVISION=10 Degrees

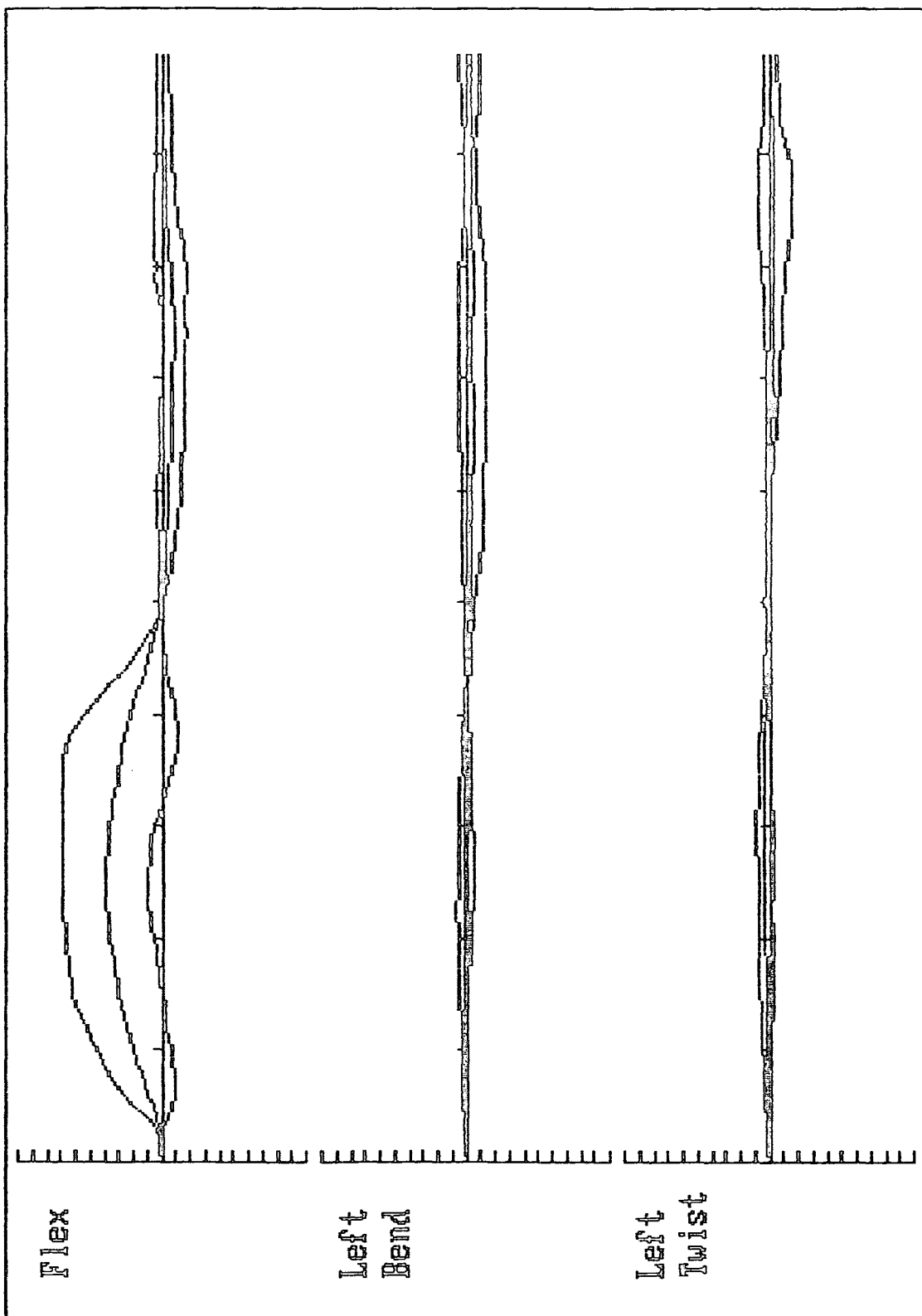

X-AXIS ONE DIVISION=1 Second
Y-AXIS ONE DIVISION=10 Degrees

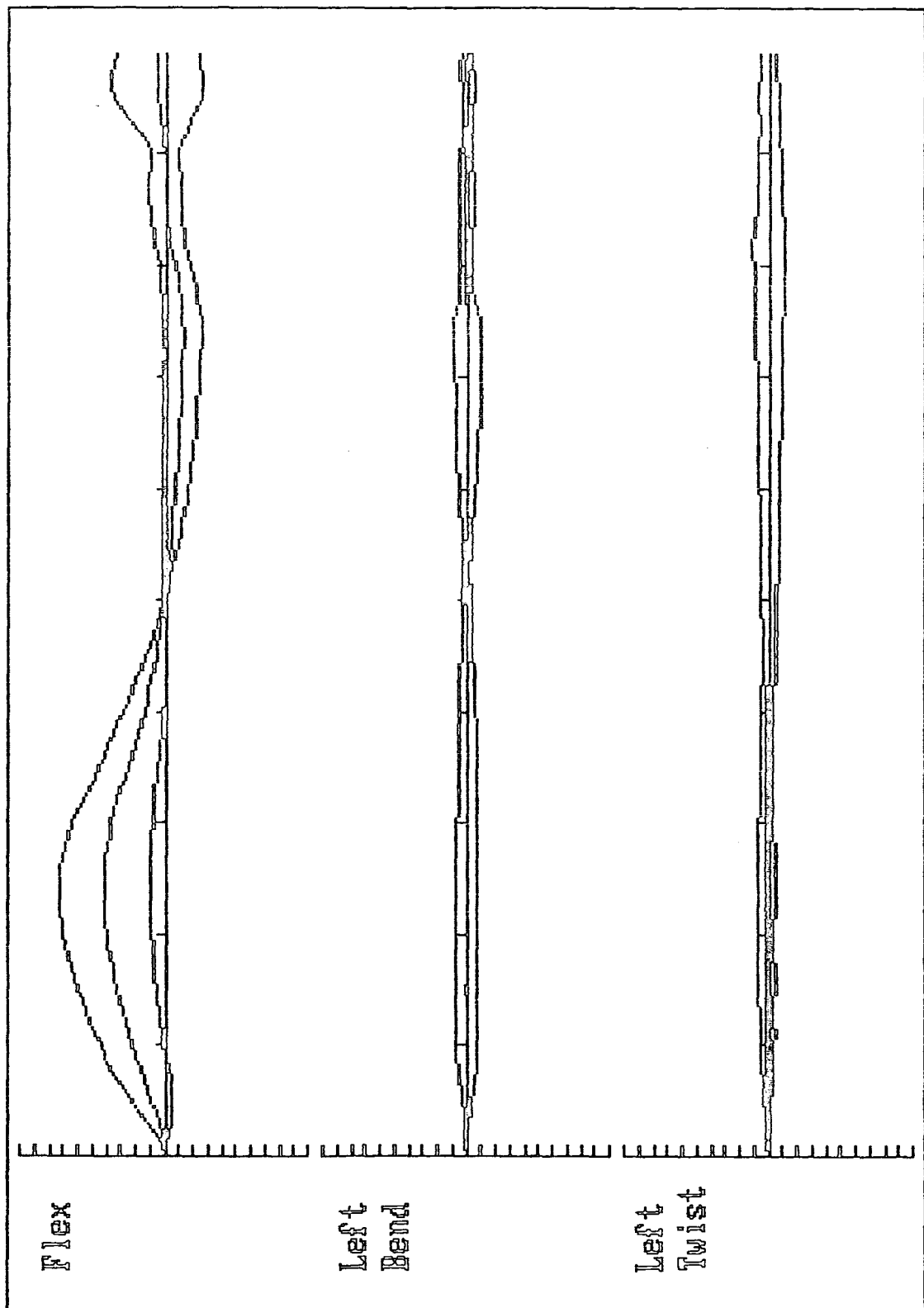

X-AXIS ONE DIVISION=1 Second
Y-AXIS ONE DIVISION=5 Degrees

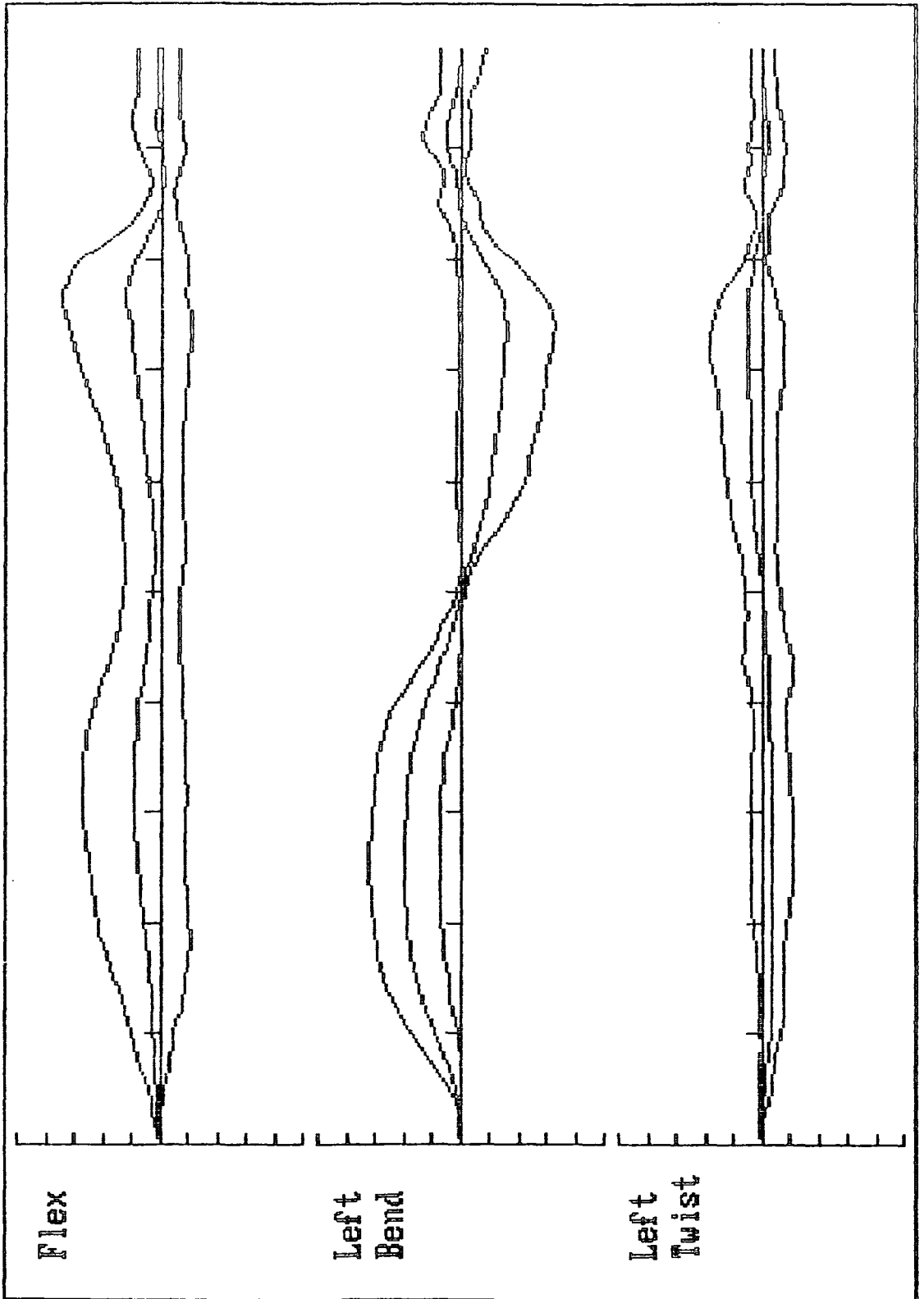

X-AXIS ONE DIVISION=1 Second
Y-AXIS ONE DIVISION=5 Degrees

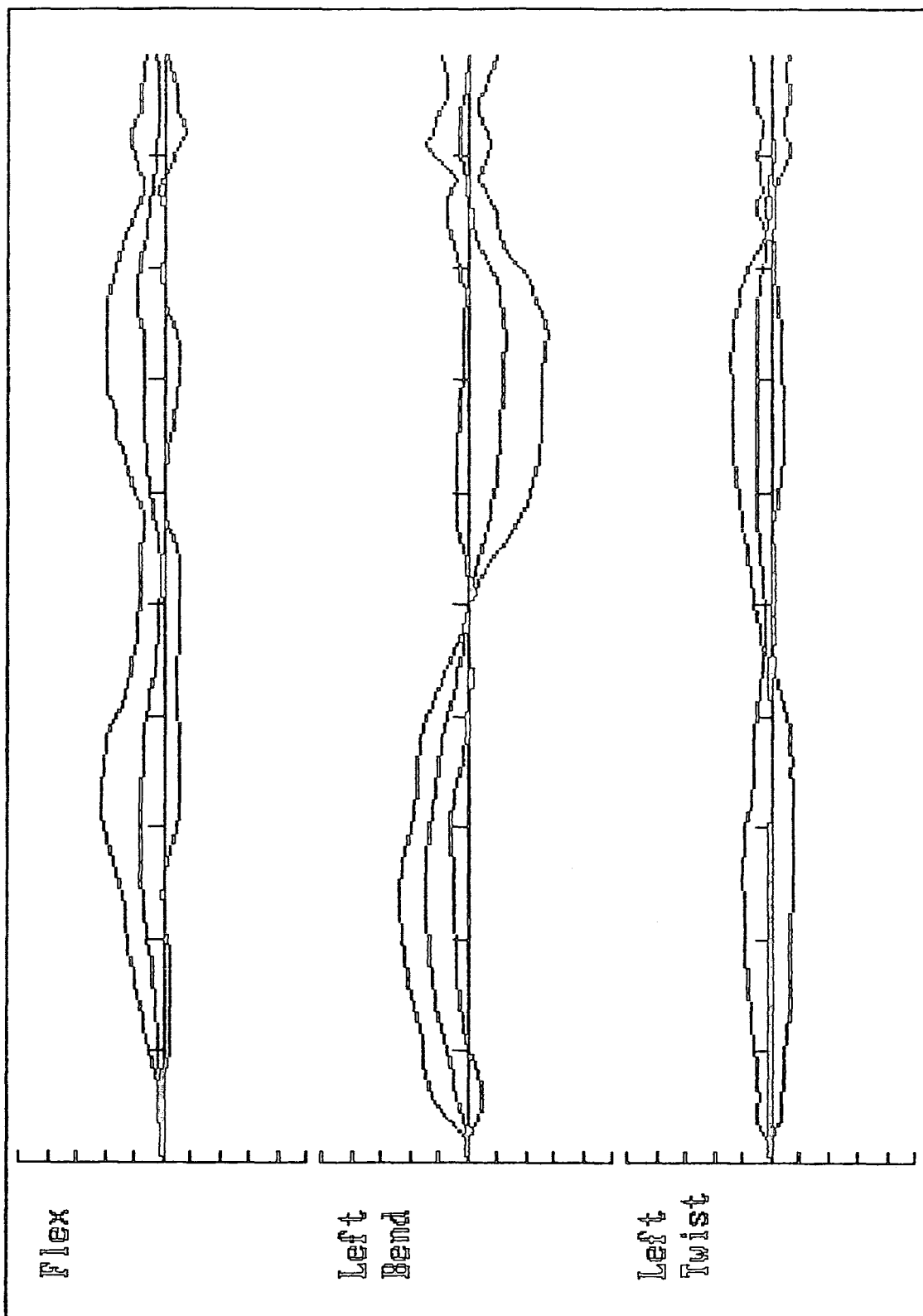

X-AXIS ONE DIVISION=1 Second
Y-AXIS ONE DIVISION=5 Degrees

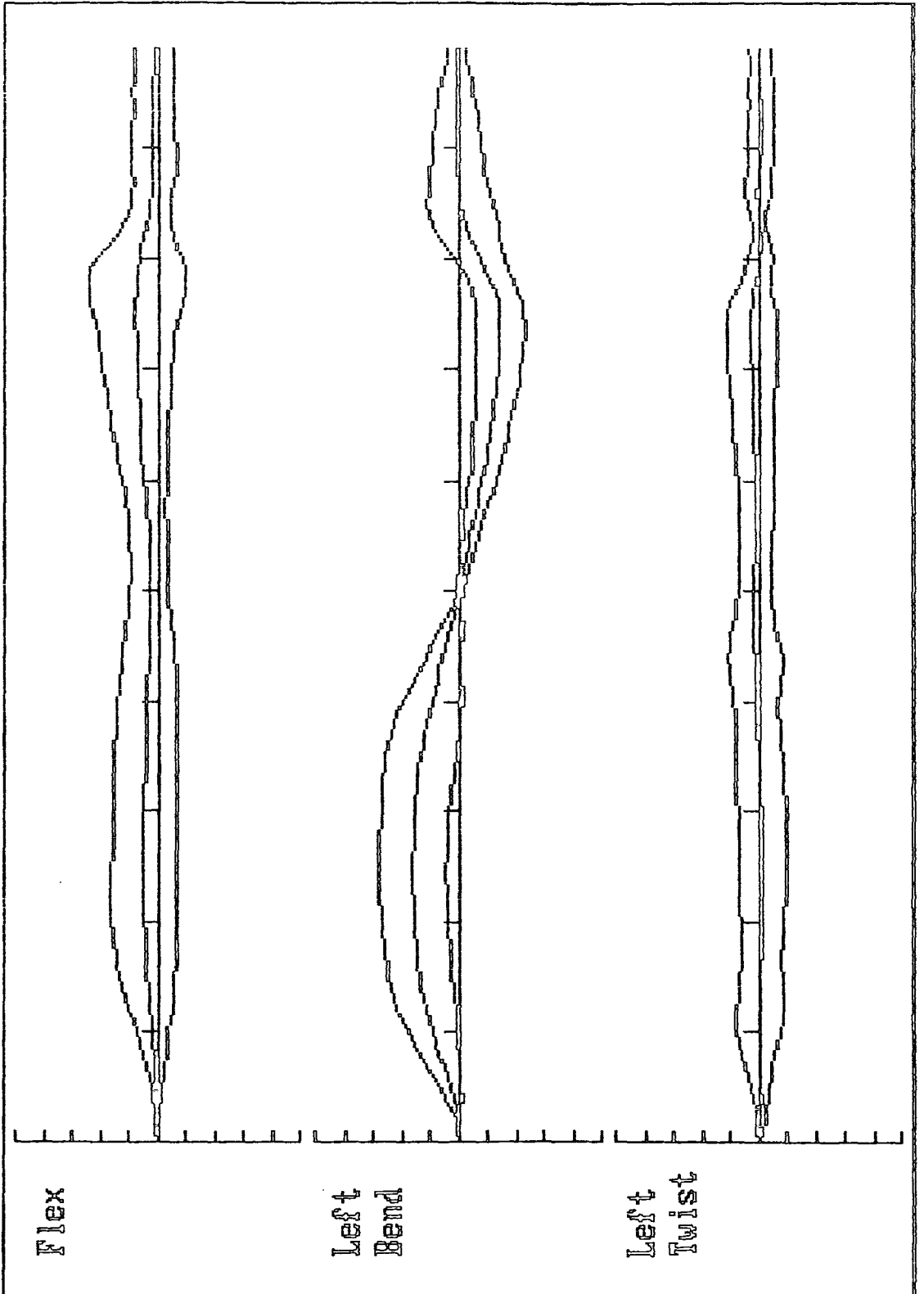

X-AXIS ONE DIVISION=1 Second
Y-AXIS ONE DIVISION=5 Degrees

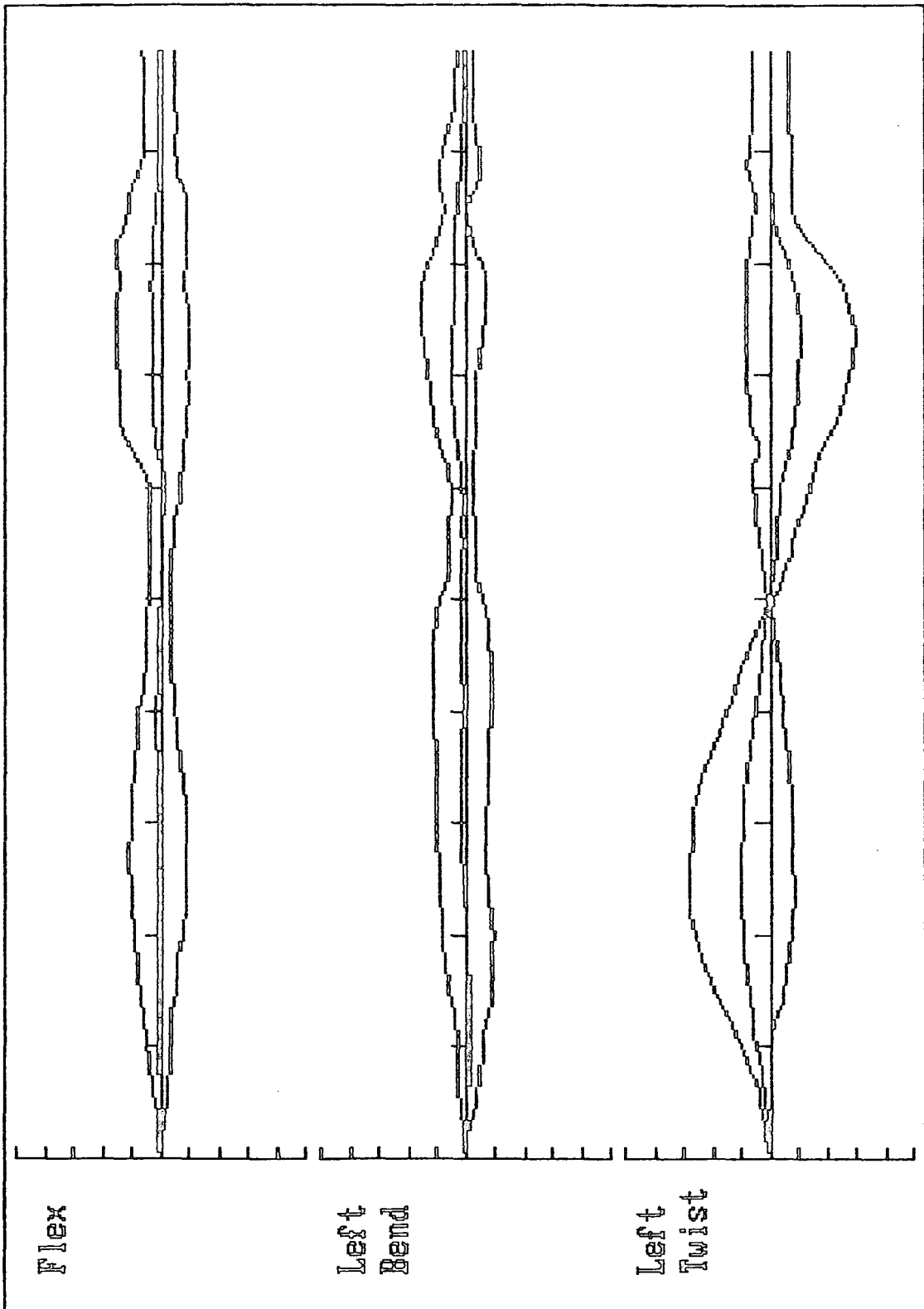

X-AXIS ONE DIVISION=1 Second
Y-AXIS ONE DIVISION=5 Degrees

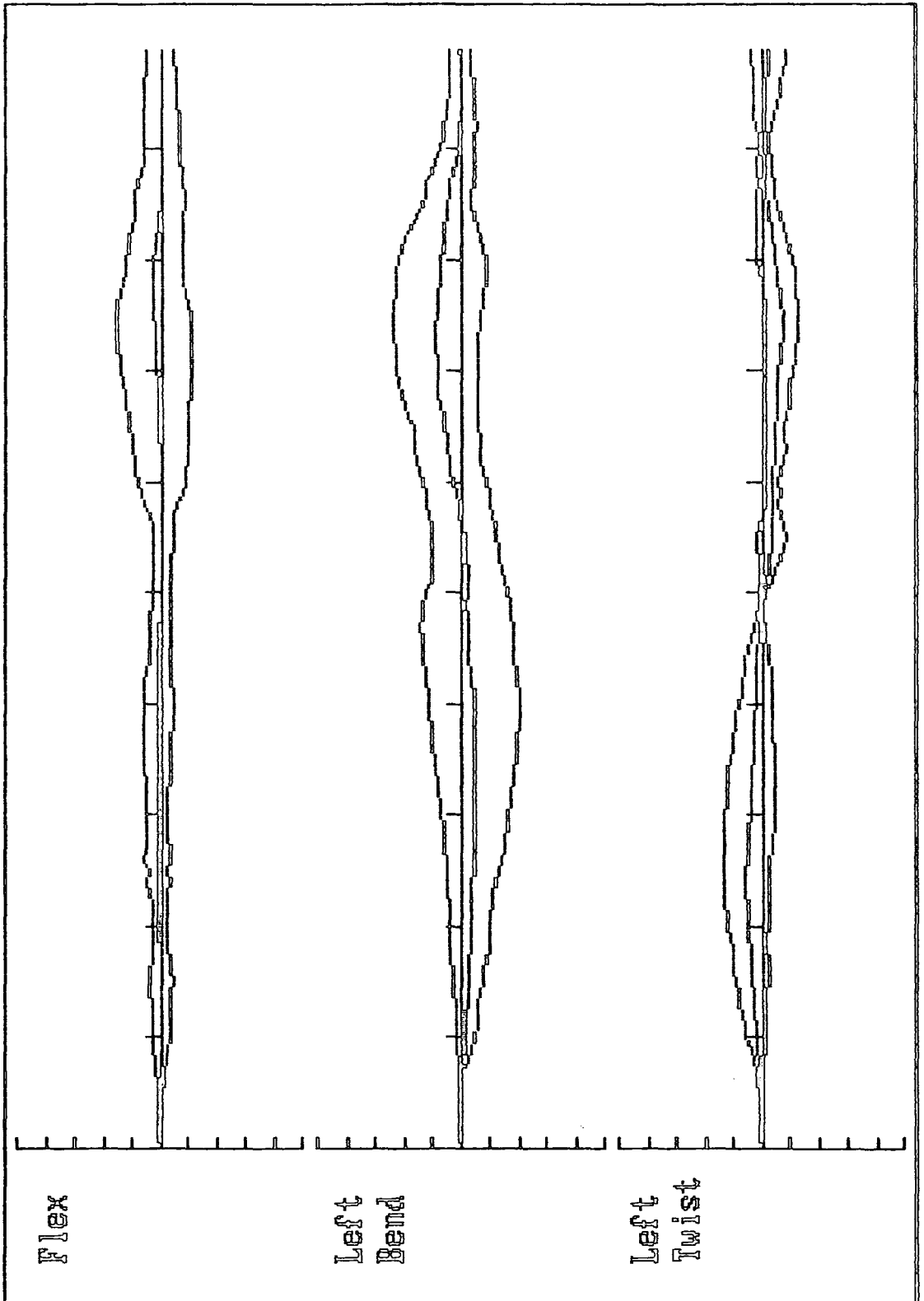

X-AXIS ONE DIVISION=1 Second
Y-AXIS ONE DIVISION=5 Degrees

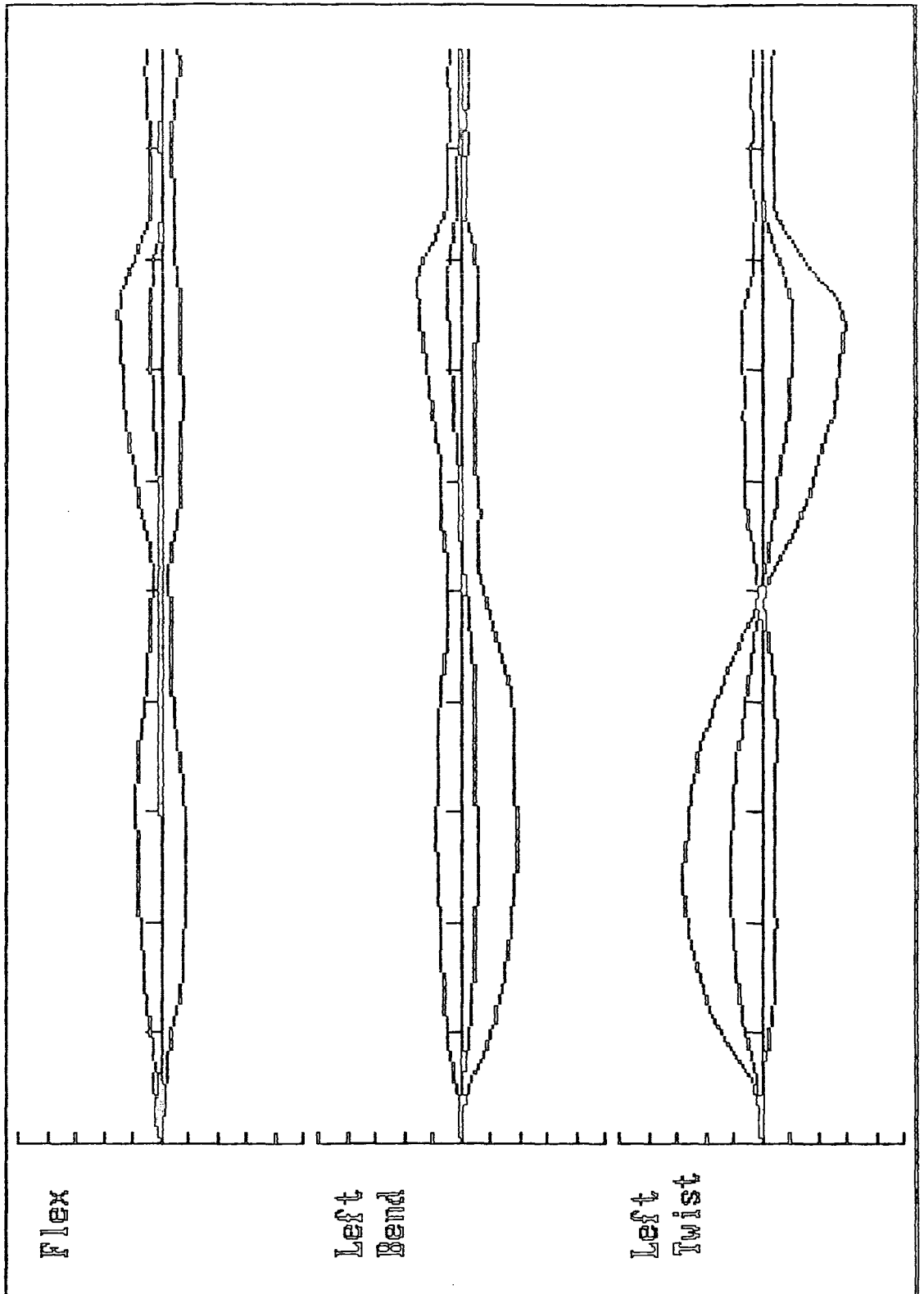

X-AXIS ONE DIVISION=1 Second
Y-AXIS ONE DIVISION=10 Degrees

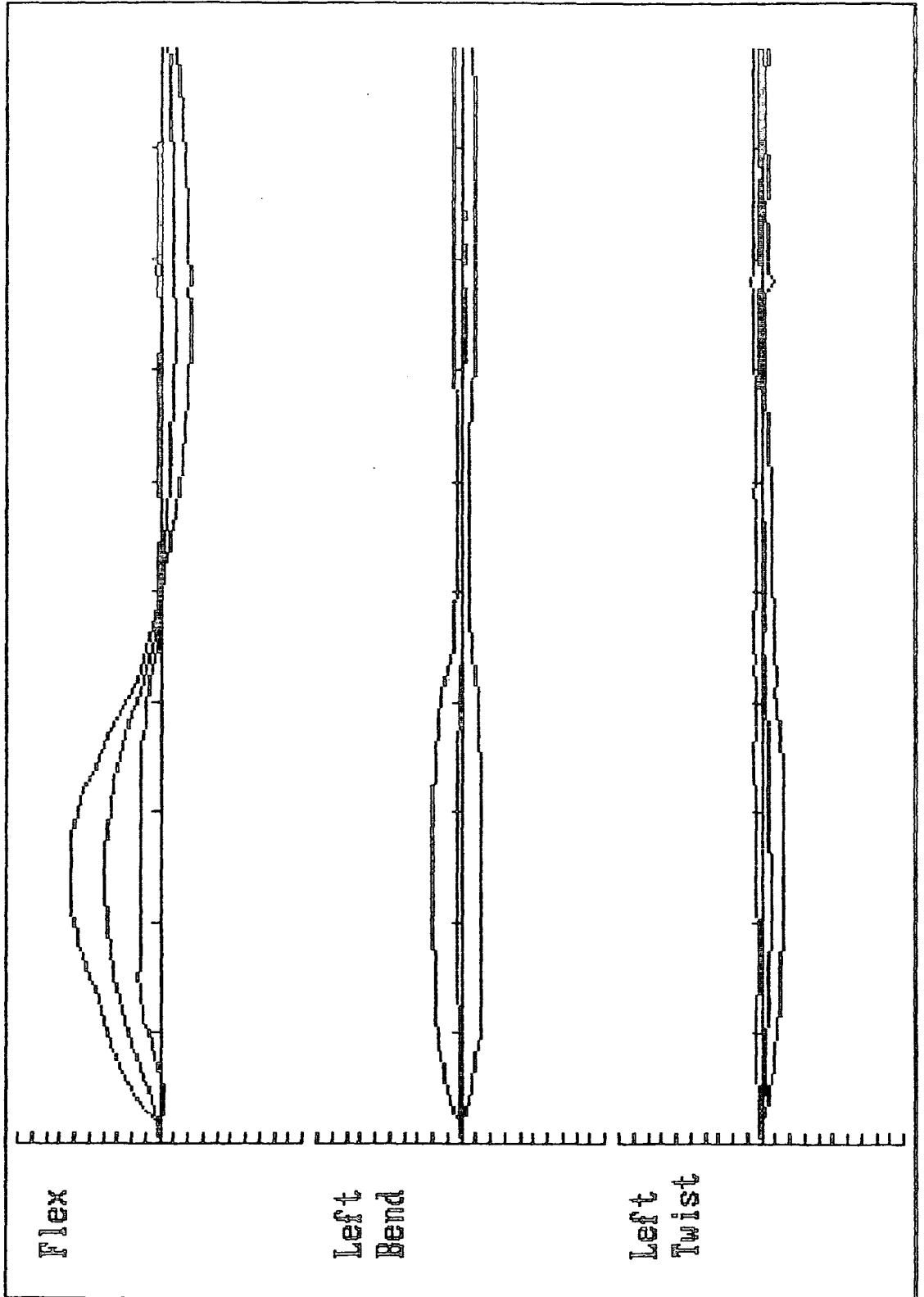

X-AXIS ONE DIVISION=1 Second
Y-AXIS ONE DIVISION=10 Degrees

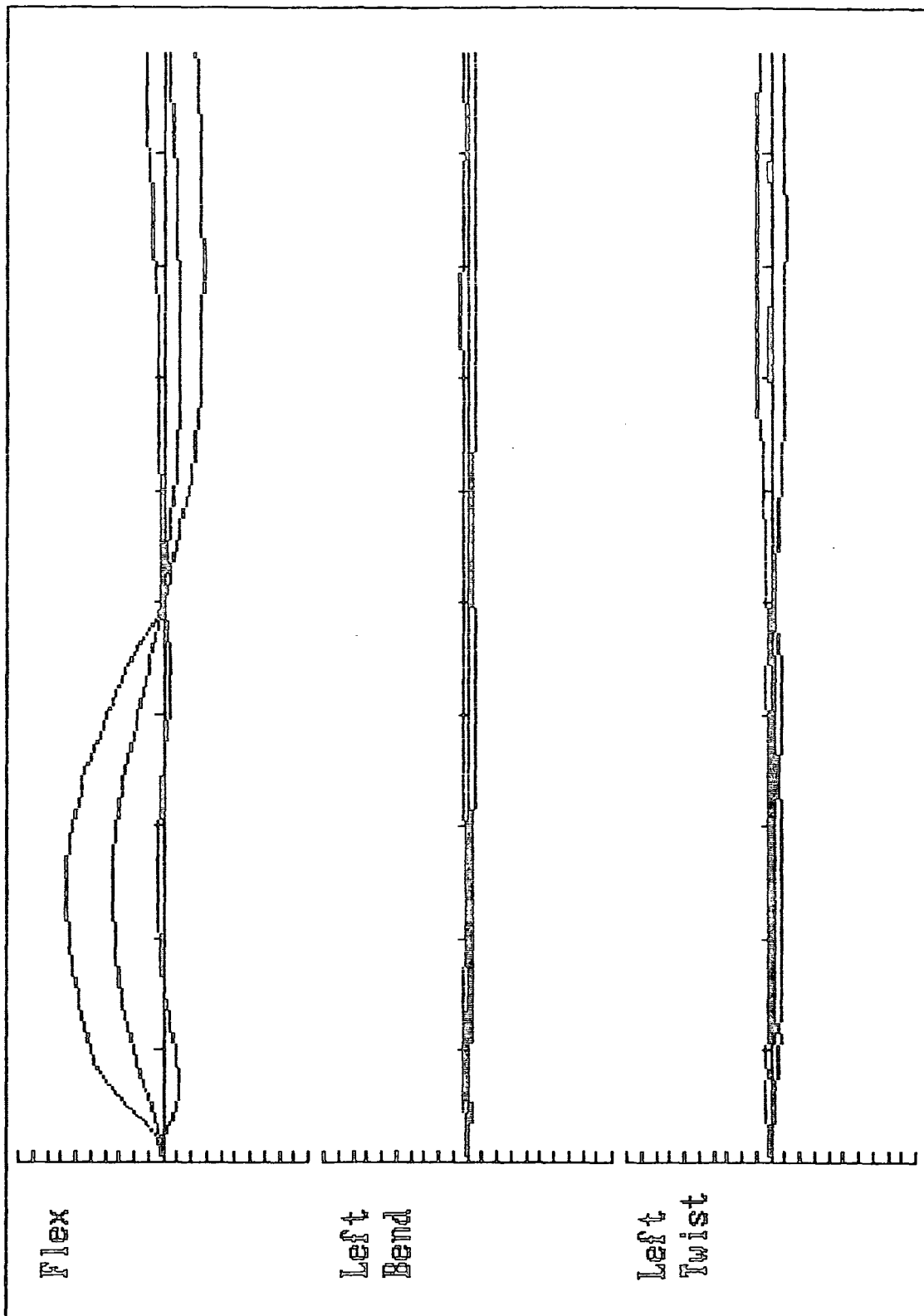

Flex

Left
Bend

Left
Twist

X-AXIS ONE DIVISION=1 Second
Y-AXIS ONE DIVISION=5 Degrees

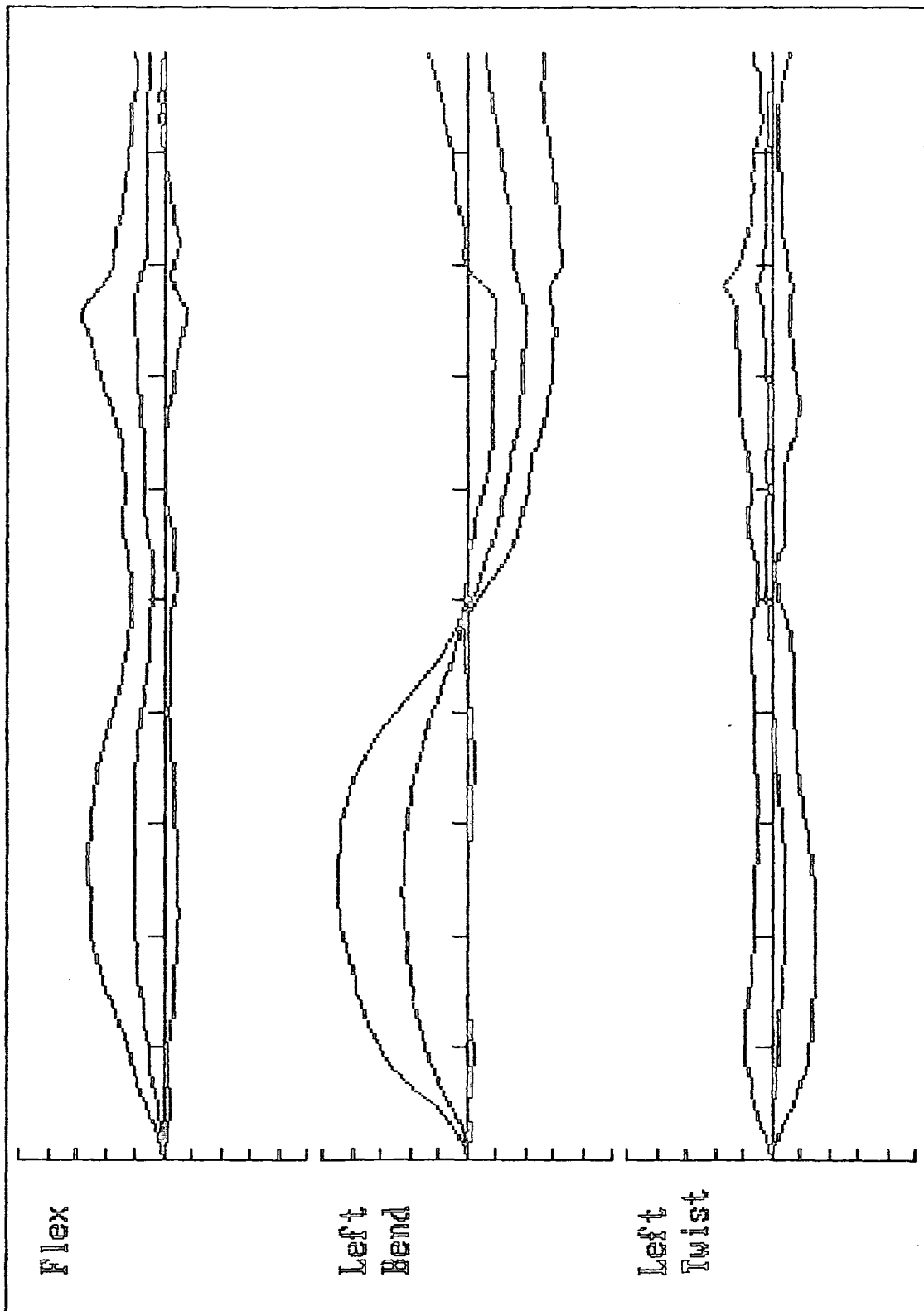

X-AXIS ONE DIVISION=1 Second
Y-AXIS ONE DIVISION=5 Degrees

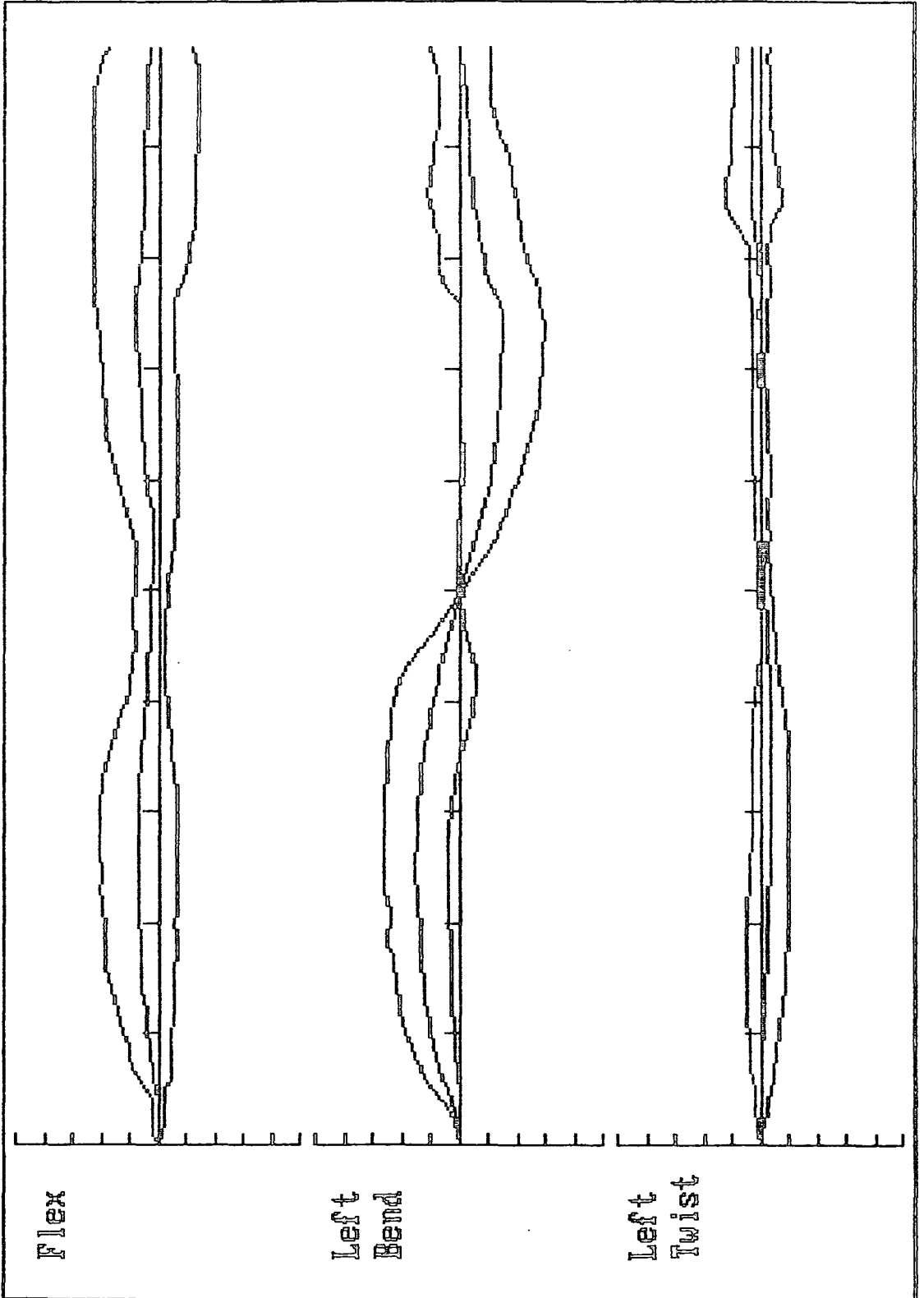

X-AXIS ONE DIVISION=1 Second
Y-AXIS ONE DIVISION=5 Degrees

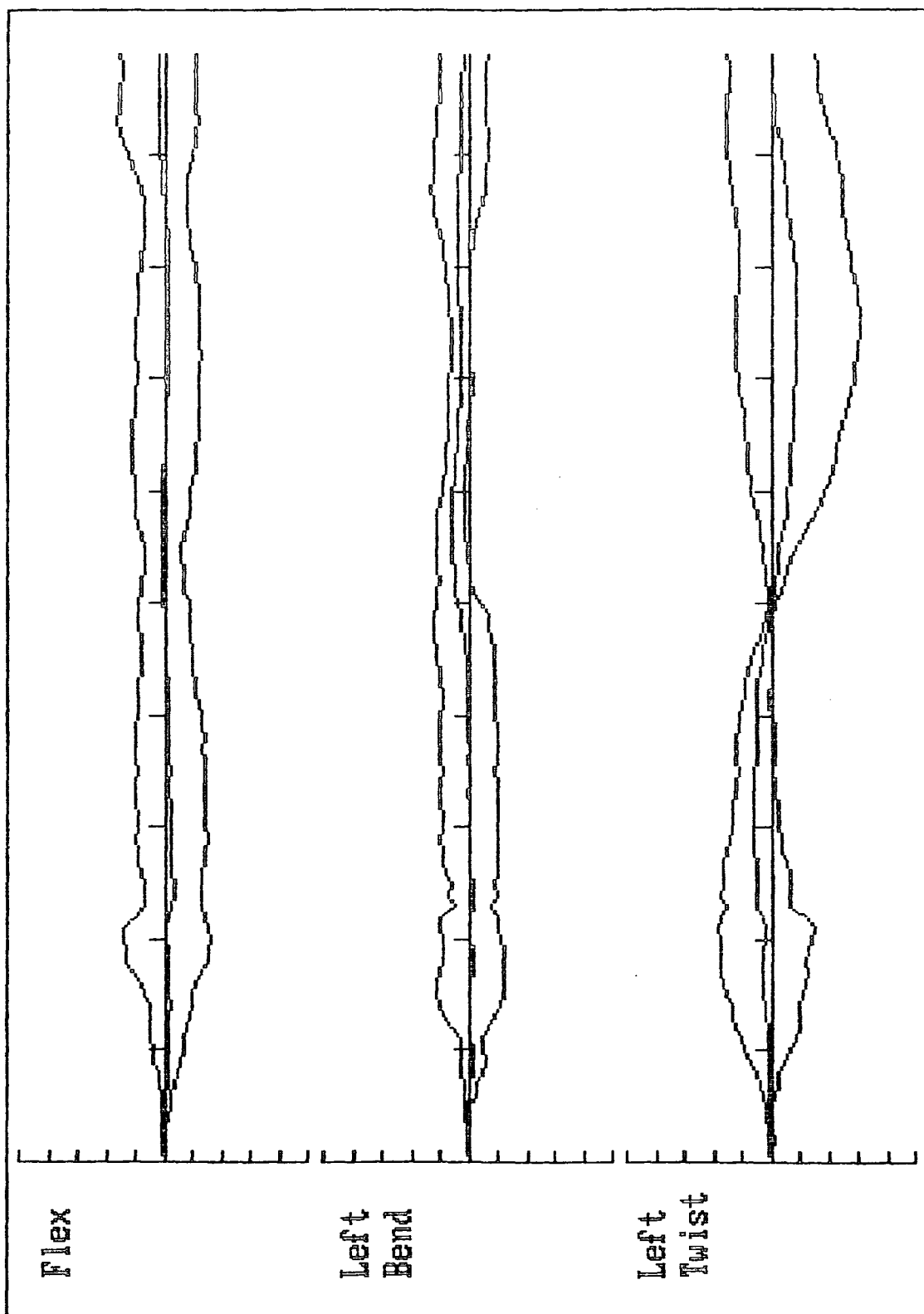

X-AXIS ONE DIVISION=1 Second
Y-AXIS ONE DIVISION=5 Degrees

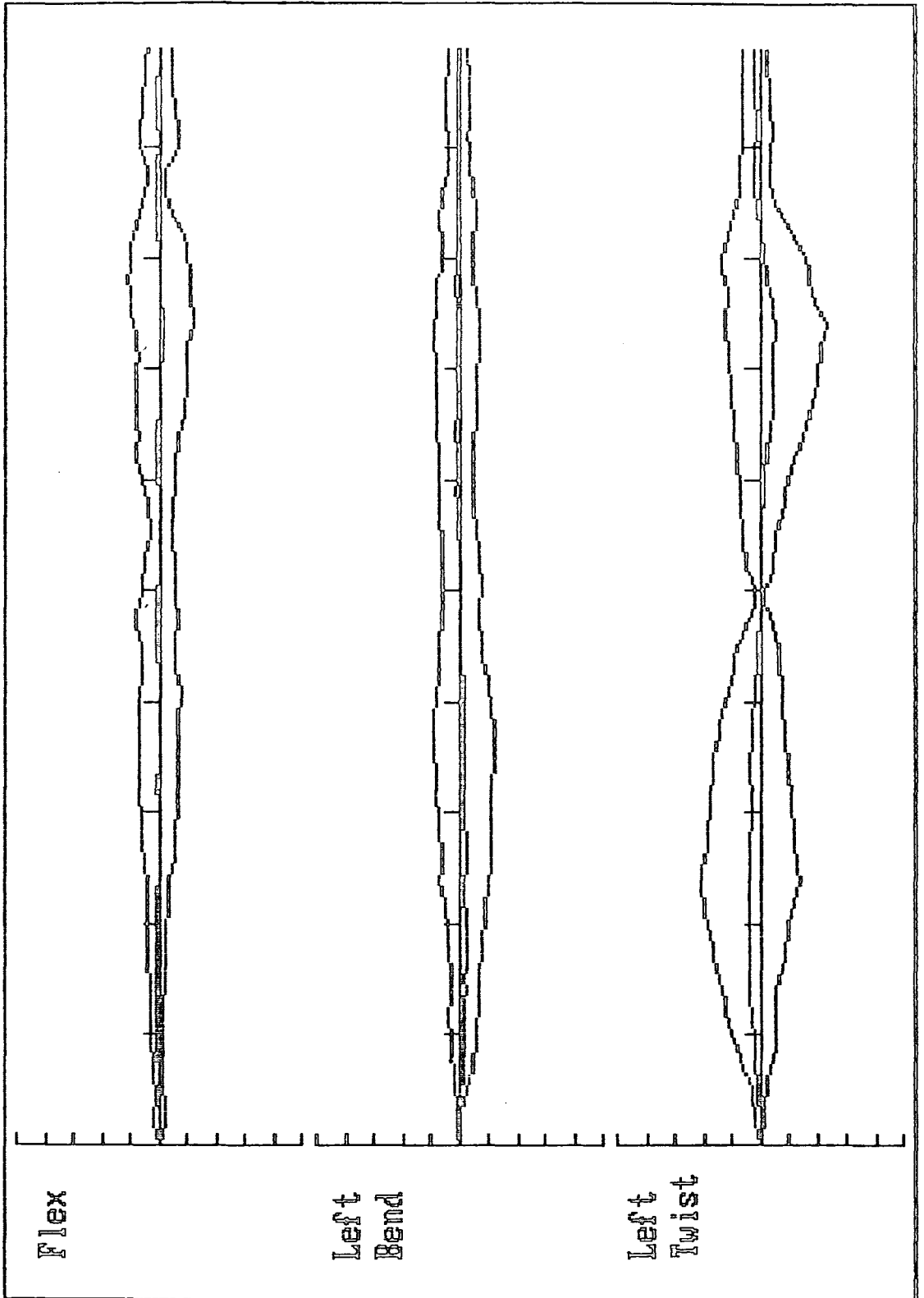

Appendix G

Sunderland Patient Details

Patient	Spasm	Tender- ness	Level	SLR < 45°	Reflex Change	Side	Sensory Change	Motor Change	Side
JT	L	M	L4-S1				L L5	EHL	L
GH		M	L5					EHL	R
LT	B	M	L5		AJ	L	L S1	PF	L
IB		B	L5	R					
ST		M	L5-S1		AJ	L	R L5-S1	PF	R
CW	B	M	L5	L			L L5		
MY		M	L3-S1						
SG		B,M	Gen						
PC		M	Gen				R L5		
DB	R	M	L5				R L5		
LF	L	M	L5-S1	R			R S1	EHL,EV	R
RW		M	L4-S1				R NS	EHL,EV	L
DN		M	L5						
AA		M	L5						
ET	L	M	L5-S1		AJ	R	R S1	EHL	R
ED	R	M	L4-5	R	AJ	R	R L5	EHL	R
TL		L,M	L4-5				L L5		
LR		L,M	L5-S1	B					
AB	R	M	L5-S1	R	AJ	R	R S1		
PR	L	M	L5-S1						

G.1 Notes

1. The entries for tenderness indicate midline (M), right (R) or left (L) para-

spinal tenderness and the level(s) involved (Patient SG had general tenderness).

2. SLR < 45° indicates whether or not the patient's straight leg raising test was less than 45° on the specified leg.
3. The entries for reflex change indicate ankle-jerk (AJ) or knee-jerk (KJ) and the side of change; right (R) or left (L) leg.
4. The entries for sensory change indicate the side of change and level involved.
5. The entries for motor change indicate changes in plantar flexion (PF) and eversion (EV) of the foot. EHL refers to change in the function of the Extensor Halux Longus muscle.

Appendix H

Prior Publications

This appendix contains material published during the course of this thesis.



Twisting of the human back in forward flexion

R J Hindle, BSc and M J Pearcy, PhD, CEng, MBES

Bioengineering Research Group, School of Engineering and Applied Science, University of Durham

J M Gill, PhD, MBES and G R Johnson, PhD, MBES

Department of Mechanical Engineering, University of Newcastle upon Tyne

This paper addresses the role of torsion in the production of spinal injury and in particular the possibility of injury resulting from torsion combined with flexion. The back movement of 16 normal male subjects was measured using a non-invasive, three-dimensional measurement system for assessing spinal mobility, the opto-electronic CODA-3 scanner. Measurements were made of the ability to twist the back while standing upright and in two flexed postures. Rotational ability was shown, in general, to be increased in a flexed posture, presumed to be due to an opening of the lumbar zygapophysial joints. This suggests that twisting in a flexed posture could be a mechanism for intervertebral disc injury.

1 INTRODUCTION

There is considerable controversy in the literature over the role of torsion in the production of intervertebral disc degeneration and prolapse.

On one side Farfan (1) and colleagues have been maintaining since the late 1960s that torsion is the most important factor in the initiation of annular damage. They produced annular ruptures similar to those that occur *in vivo* by subjecting intervertebral joints to forced rotations finding that an average rotation of some 22.6° was required to produce failure in whole joints with normal discs.

The normal physiological range of axial rotation for the lumbar spine is 8–10° or approximately 2° per joint (2, 3). It would seem, therefore, that under ordinary circumstances it is impossible for an intervertebral disc to be damaged as a result of rotation. However, Farfan maintained that any joint rotated to more than 3.5° must receive injury to the disc (1).

More recently several researchers have produced contrary evidence. Adams and Hutton (4), for example, believe torsion to be unimportant in the production of disc degeneration and prolapse. They concluded that torsion is resisted primarily by the zygapophysial joint that is in compression and that this is the first structure to yield at the limit of torsion. In joints with normal discs this limit of torsion occurred at 1–2° of rotation.

Liu *et al.* (5) investigated the effect of cyclic torsional loading on intervertebral joints and they also concluded that torsion was unimportant in the initiation of disc degeneration and prolapse, but added that as degeneration progresses torsion contributes to joint instability.

Shirazi-adl *et al.* (6) constructed an extensive finite element model of an L2-3 motion segment and as a result of their analysis they concluded that torque alone cannot cause the failure of disc fibres but that it could enhance the vulnerability of the posterior and posterolateral fibres when the torque acts in combination with other types of loading such as occurs in flexion.

An examination of the morphology of the intervertebral joints in relation to their mechanics indicates that the lumbar zygapophysial joints are shaped such that

during flexion, when they become distracted, an increase in rotational capacity may well result. This mechanism is demonstrated in Fig. 1. Thus a working hypothesis can be expressed as follows. The lumbar spine has a greater ability to twist when in a flexed posture than in the upright posture, suggesting that it is vulnerable to torsional injury when flexed.

The present study used a three-dimensional measurement system to examine this proposal by measuring the amount of voluntary axial rotation that subjects could perform whilst in flexed postures.

2 METHODS

2.1 The CODA-3 scanner

The CODA-3 scanner* (Fig. 2) sends out three fan-shaped beams of light to retro-reflective prisms attached to a subject. The light, produced by a Xenon arc lamp, is split and sent out by three octagonal, synchronized rotating mirrors, two mounted on vertical axes one metre apart and the third on a horizontal axis between

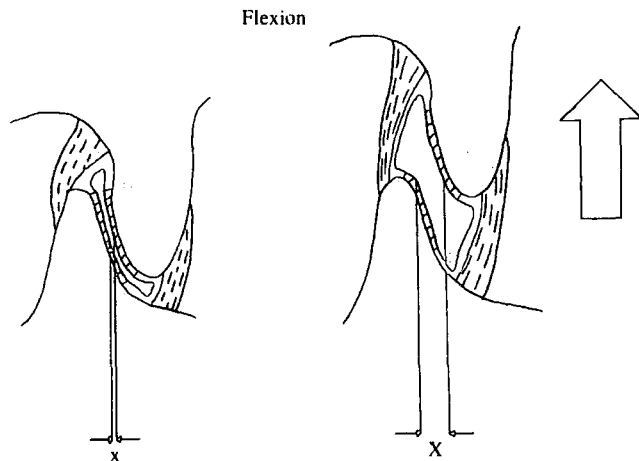

Fig. 1 A posterior view of a lumbar zygapophysial joint demonstrating increased rotational ability (X) through joint distraction

*The MS was received on 18 November 1988 and was accepted for publication on 8 February 1989.

* Movement Techniques Limited, Loughborough.

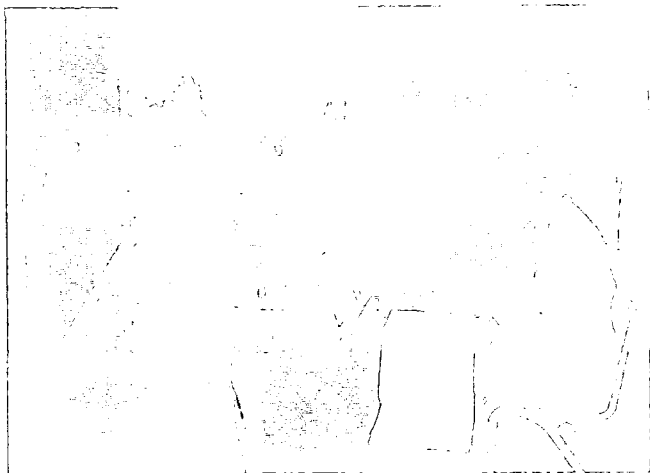

Fig. 2 The CODA-3 scanner

the two. When a beam of light crosses a landmark, made up of four retro-reflective prisms arranged pyramidally, a brief pulse of light is reflected back along the same path to photodiodes in the scanner unit where it is detected; the orientation of the mirrors when the reflected light is detected enables the position of the marker to be calculated by simple geometry. The mirrors rotating on vertical axes give the position in a horizontal plane and the third mirror, on its horizontal axle, gives the vertical height, so providing the instantaneous Cartesian coordinates of the landmark. Each marker is uniquely identified by colour and so the system can track several markers at once.

The major, and restricting, problem with the CODA-3 scanner is the situation referred to as cross-over conflict. When any two markers come within approximately 25 mm of each other in a horizontal or vertical plane the machine loses the information about their positions. Markers, therefore, have to be arranged carefully so that the movements of interest do not cause conflict.

The problem of marker arrangement was tackled by Kelly (7) in the only previously reported attempt to use CODA-3 for measuring spinal motion. She placed markers over the lumbo-sacral spine by mounting them directly on to the skin and had some success in measuring flexion-extension and lateral bend. However, to calculate three-dimensional rotations accurately markers in rigid configurations must be used in order that planes attached to body segments may be defined (8). This was achieved for the present study by mounting the markers on rigid plates rather than on the skin, which deforms during movement.

Two marker rigs were used, each with three prismatic markers attached (Fig. 3). The first marker rig was strapped over the sacrum and established the reference frame to which relative movements of the second rig were defined. The second marker rig was attached over the spinous process of L-1 with double-sided tape and by two elastic straps passing around the subject. A wedge of foam, contoured to the shape of the back, was placed between the base of the rig and the subject's back in order to stop the whole rig being displaced by the underlying muscles upon rotation.

The scanner unit was set to sample at a frequency of

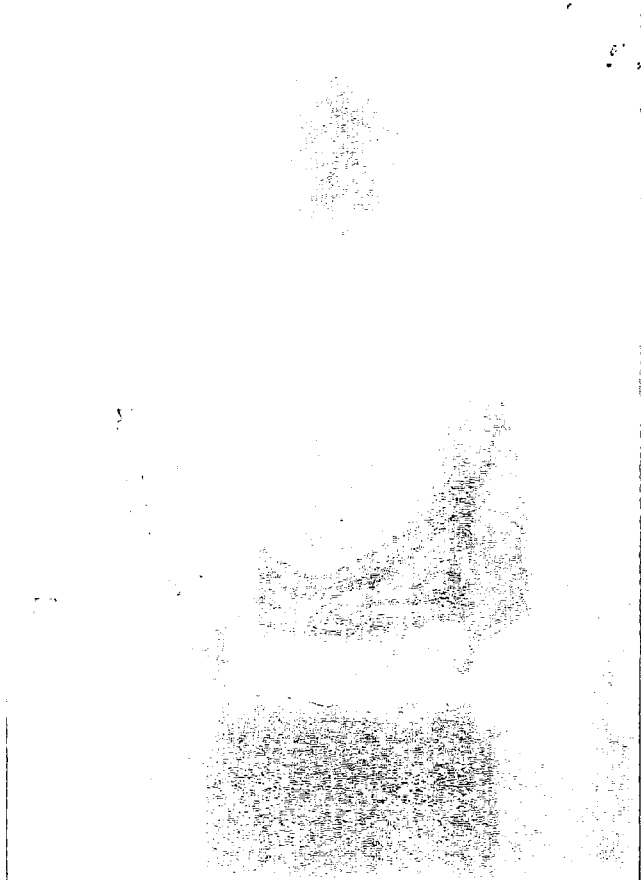

Fig. 3 The two marker rigs, each with three reflective markers, attached to a subject

10 Hz over a ten second period. This sampling rate was judged to be sufficient for the relatively slow movements of the back.

2.2 Subjects

Sixteen male subjects aged between 20 and 56 years of age participated in the study. All denied any back pain in the six months previous to the study and none had undergone spinal surgery.

2.3 Procedure

Ranges of voluntary maximal flexion and extension were first measured in all subjects. Subjects were positioned in a metal frame with their anterior superior iliac spines against adjustable plastic pads. These acted to align the subject with the coordinate axes of the measurement system. Hip motion was limited by means of a belt strapped firmly around the buttocks in order that the markers did not cause conflict or go out of the field of view.

During the ten second period when data were recording each subject had to first flex forwards as far as possible, with their hands by their sides, before returning to the upright position and then extending maximally and again returning to the start position. The procedure was then repeated, assuming satisfactory data had been collected in the first instance, with the subjects first extending then flexing.

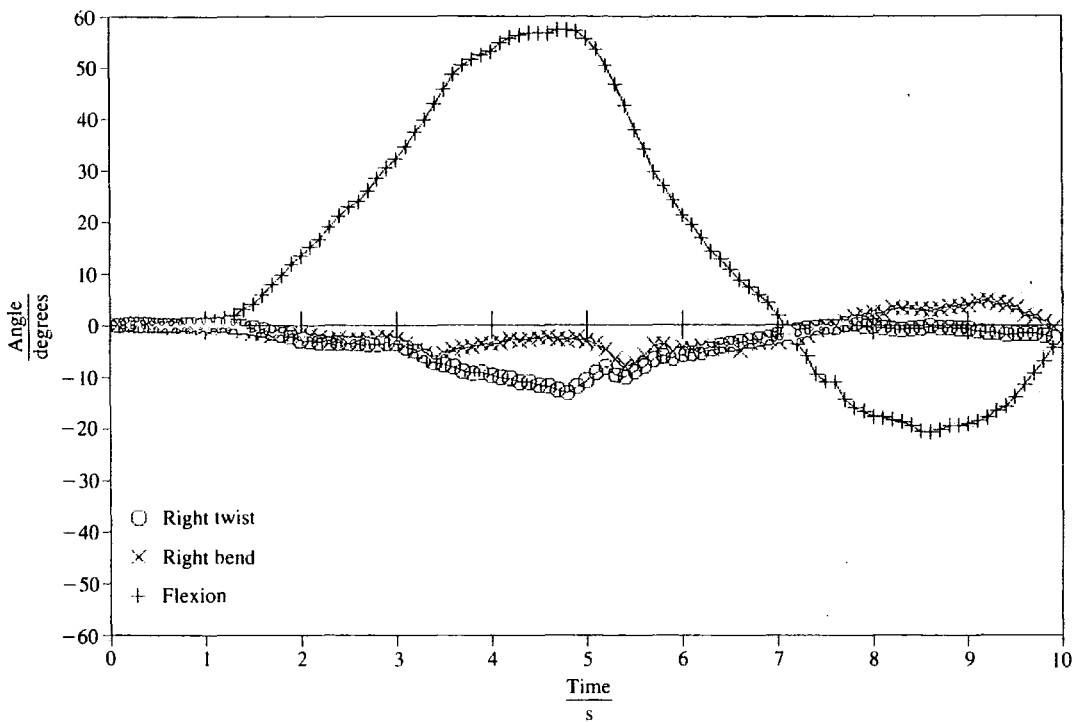

Fig. 4 Data from a subject performing voluntary flexion and extension in the standing position

Subjects remained secured in the frame for the measurement of maximum voluntary axial rotation. For this the subjects crossed their arms over their chests and twisted maximally to right and left. The measurement was then repeated with the subject twisting first to the left and then to the right.

Rotation was then measured in two seated postures that were intended to induce a certain degree of sagittal flexion.

In the first the subject was seated on a stool with knees flexed. In order to define the seated posture subjects started the sequence standing upright, they then sat down and twisted maximally to each side. Since some degree of flexion was required subjects were simply asked to sit in a comfortable and relaxed way as this inevitably meant the resulting posture was somewhat 'slumped'.

The second seated posture required the subject, upon sitting down, to raise his legs onto another stool so that his knees were now extended. Rotation was recorded as before.

The measurements were recorded after the subject had practised each new movement. A measurement was repeated if marker conflict caused a loss of information.

2.4 Data analysis

From the three-dimensional coordinates of the prismatic markers for the 100 data points in each measurement period the relative rotations between the two marker rigs were calculated as the subject moved to give angles of flexion-extension, lateral bend and axial rotation. A more detailed explanation of the analysis technique is given elsewhere (8). Subsequent to each measurement a graphical presentation of the three angles was produced against time.

3 RESULTS

3.1 Subject trials

All 16 subjects produced results for ranges of flexion and extension. However, only 12 of the 16 gave a full set of data for the measurement of axial rotation in the standing and two seated positions. The remaining four were excluded for one of three reasons:

1. Two subjects were excluded because of a combination of cross-over conflict problems and failure of the CODA-3 hardware.
2. One subject was found to be too short to sit on the stool without first adopting an unnatural posture which affected his subsequent movements.
3. One subject failed to display any flexion in the two seated postures and complained of the sensation of 'falling backwards'; since the aim of the experiment was to examine rotation in various degrees of flexion he was excluded.

3.2 Flexion-extension

The results for the maximum voluntary ranges of flexion and extension obtained are shown in Table 1 compared with results obtained by biplanar radiography in normal young males (3). The pattern of movement from a typical subject is shown in Fig. 4.

3.3 Axial rotation

The two seated postures were found to have significantly increased the subjects' anterior flexion from the normal standing position. Taking the subjects' standing posture as zero flexion and maximum flexion as that value achieved in the previous determination of ranges of flexion and extension then the first seated posture induced, on average, some 40 per cent of a subject's maximum flexion. The second seated posture, with feet

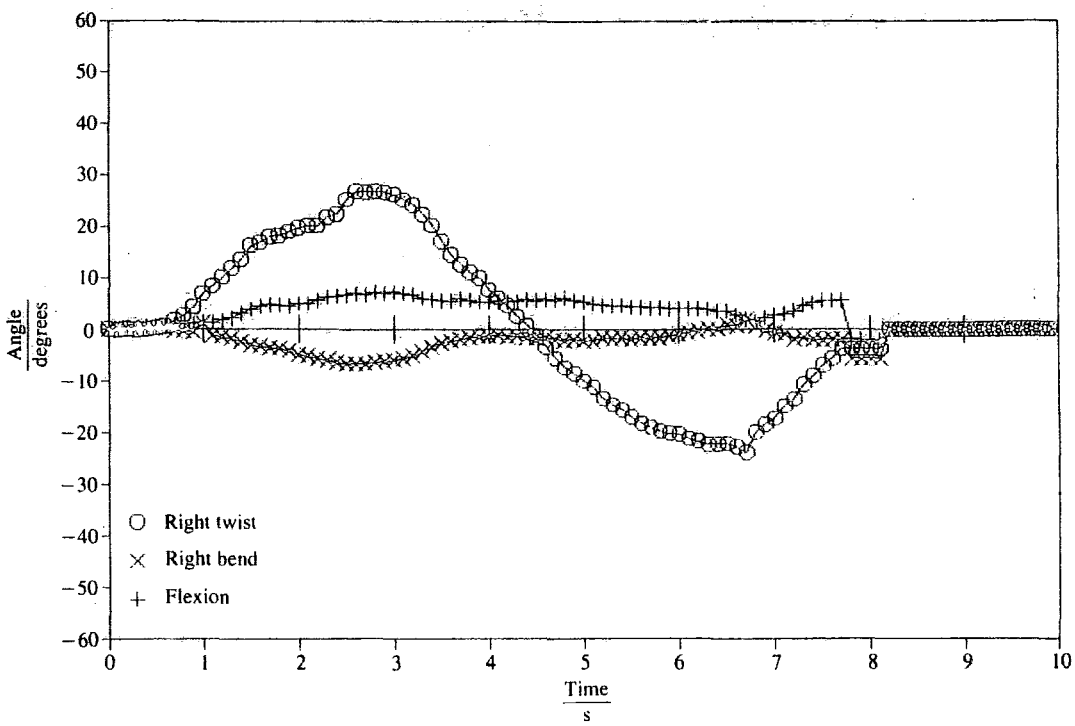

Fig. 5 Data from a subject performing maximum voluntary axial rotation while standing

raised, inducing about 65 per cent of maximum flexion. It was found that expressing the amount of flexion induced as a percentage of maximum, rather than absolute angular values, helped reduce the considerable individual variation present.

Typical plots obtained for a subject's axial rotation in the three postures are shown in Figs 5, 6 and 7. The plot showing maximum voluntary axial rotation in the standing position (Fig. 5) shows the subject twisting first

to the right and then to the left. Some coupled flexion is demonstrated as is some left bend with right twist although no right bend is apparent with left twist. The two plots for the seated postures (Figs 6 and 7) show clearly the considerable flexion that each posture induced, this being maintained throughout the test period.

When the results for maximum voluntary axial rotation in each of the three postures were considered

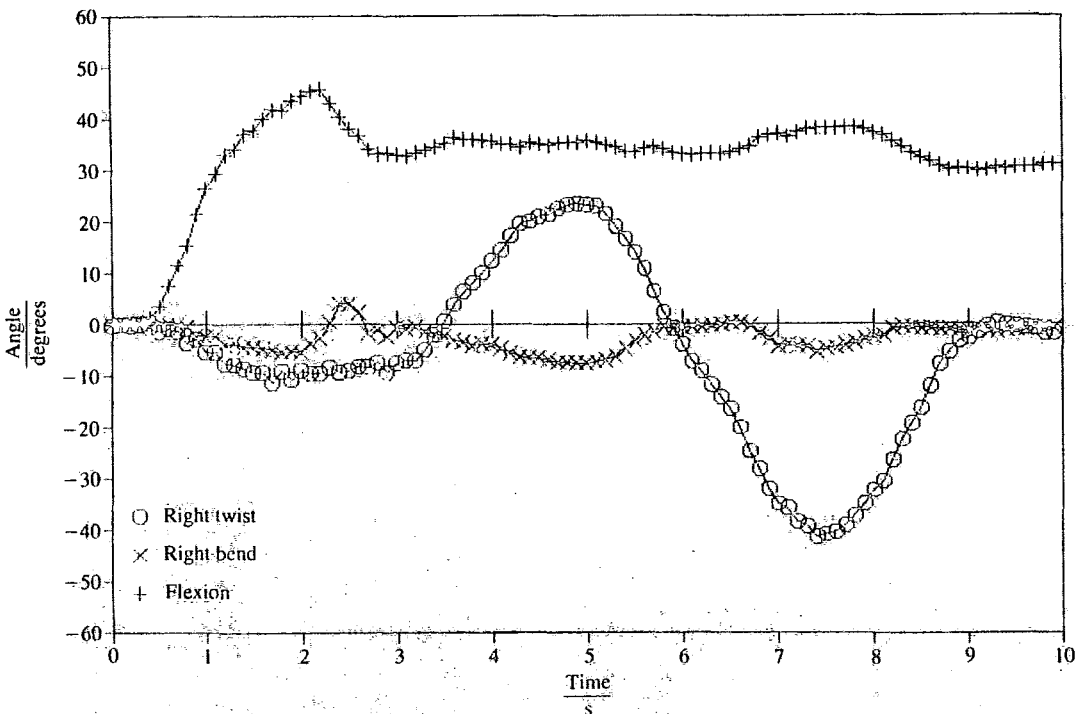

Fig. 6 Data from the same subject performing maximum voluntary axial rotation while seated

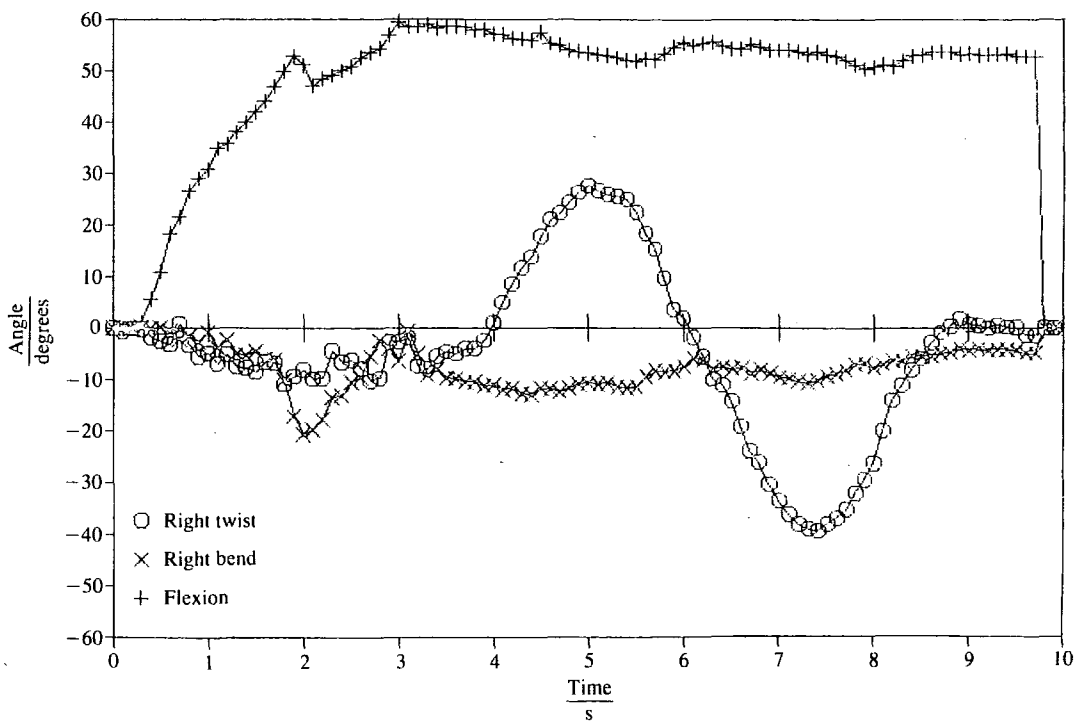

Fig. 7 Data from the same subject performing maximum voluntary axial rotation while seated in a flexed posture

together an increase in rotational ability was found to be present in both of the flexed postures. This was found to be statistically significant ($p < 0.05$, student's T -test) between the standing and most flexed seating postures (Fig. 8). The standard deviations about the mean values of axial rotation are seen to increase at each posture (Fig. 8), this is due to the variation in the amount of flexion produced in each subject by the two seated postures (Fig. 9).

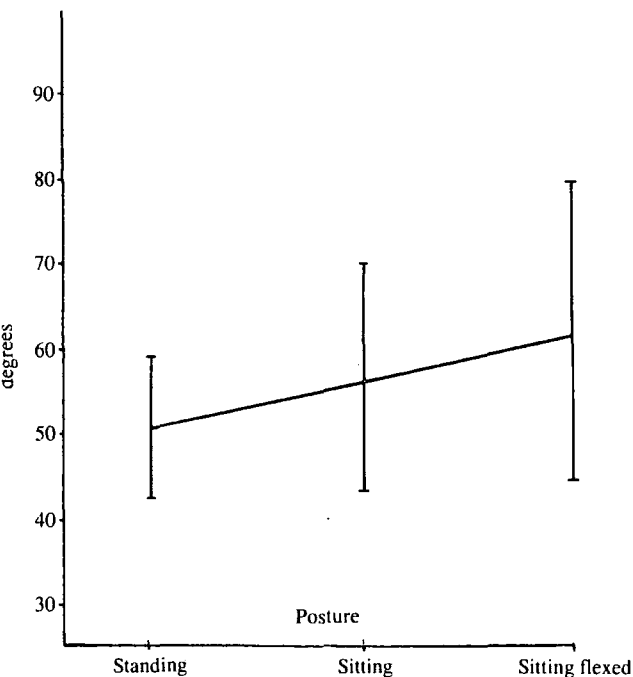

Fig. 8 The maximum voluntary axial rotation obtained in the three postures marked with standard deviations across the means

4 DISCUSSION

As can be seen from Table 1 the mean values obtained for ranges of flexion and extension agree broadly with the figures obtained from a sample of healthy young men using biplanar radiography (3).

A comparison of the values of standing maximum voluntary axial rotation, having a mean of some 50.5° , with those of the same radiographic study show that the values obtained in this study are greatly in excess of true lumbar spine capacity, some $8-10^\circ$ (3). This exaggeration in movement can be explained by considering the straps used to attach the top marker rig to the subject (Fig. 3). The top elastic strap passed around the upper thorax and so, as a result, considerable rib cage motion was included in the values of rotation seen. However, this accepted, comparison of values between and within subjects still remains valid. Percy *et al.* (9) have recently shown that patterns of motion, although different in magnitude, obtained with the marker rigs are remarkably similar to those obtained from biplanar radiography.

As previously noted true lumbar rotation is in the region of 10° . (2, 3) approximately one-fifth of the value obtained here. If the same fraction of the increase in

Table 1 The mean values of maximum voluntary flexion, extension and axial rotation, in degrees, obtained from this study compared with values from biplanar radiography

Movement	CODA-3		Three-dimensional X-ray	
	<i>n</i>	\bar{x} (SD)	<i>n</i>	\bar{x}
Flexion	16	55.2 (11.8)	11	51
Extension	16	21.4 (7.7)	11	16
Total	16	76.6 (12.0)	11	67
Axial rotation	12	50.8 (8.9)	10	50

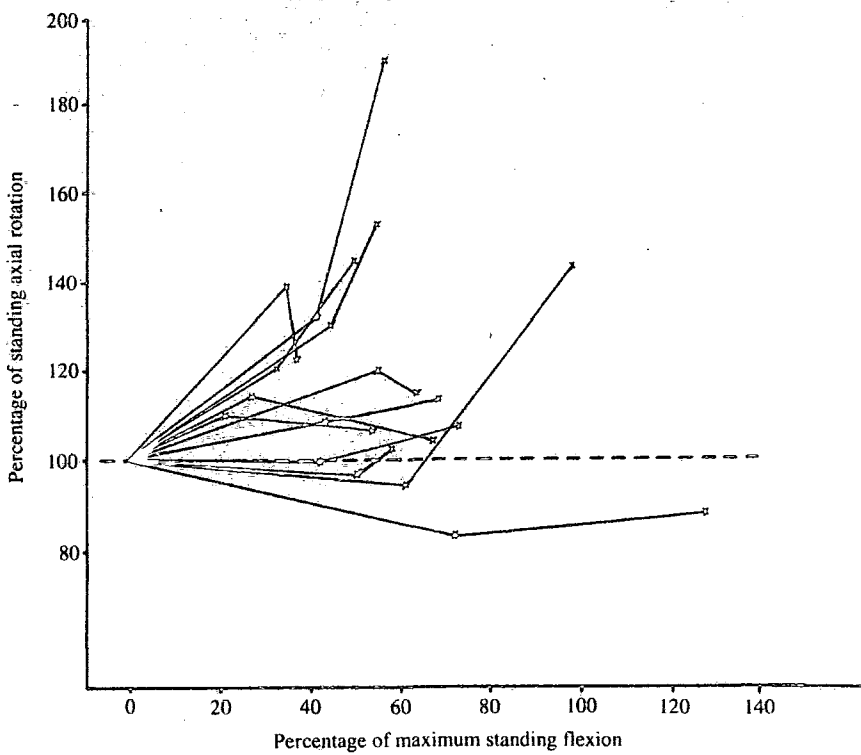

Fig. 9 Percentage of standing axial rotation plotted against the percentage of flexion in the standing position, in each posture, for all subjects

rotation seen here is attributed to the lumbar spine, the mean increase being 15° per subject but reaching 30° in some, then an extra 1° of rotation per joint may be obtained. However, in reality much more of this increase can be attributed to the lumbar spine. The orientation of thoracic zygapophysial joints is such that almost unhindered rotation is available. This is demonstrated by the fact that if they are removed torsional stiffness is almost unchanged (10). Therefore, in some individuals, an extra 4-5° of rotation may be available at each lumbar joint when the spine is flexed.

The three-dimensional structure of the lumbar spine results in complex movements of the individual intervertebral joints when the trunk is twisted relative to the pelvis (3). Thus although the measurements in this study were of twisting of the trunk the joints themselves can be expected to have undergone flexion, axial rotation, plus some degree of lateral bend (Figs 5, 6 and 7). However, the same argument holds in that if the zygapophysial joints open in flexion the intervertebral joints will have a greater ability to twist and to bend laterally.

Gregerson and Lucas (2) are the only others to have measured axial rotation while standing and while seated with their technique involving the insertion of Steinman pins into lumbar spinous processes, when they

showed a slight decrease in rotation in the seated posture, which is in contradiction to the result seen here. However,

to maintain a 90° thigh-trunk angle in the seated posture, a greater flexion is required to maintain the lumbar lordosis and so restricting movement. This is by no means consistent and this may explain the variation between subjects with different degrees of flexion and rotation. The

degree to which maximum voluntary rotation will be increased by flexion is dependent upon the orientation of the facet joints; the variation in the amount of flexion that was required to produce an increase in rotational ability, as shown in Fig. 9, can be presumed to be due to this. Some subjects showed large increases in rotation for relatively small increases in flexion while others only showed an increase in rotation for large increases in flexion. One subject, who flexed more while in the seated posture than he had previously been able to do while standing upright, was the only one not to show an increase in rotation. Unfortunately it was not possible to assess the morphology of subjects' zygapophysial joints radiographically to determine if a subject's facet orientation could be related to the results observed. Despite the small number of subjects involved it would appear that in general some degree of flexion does lead to an increase in rotational ability.

Another factor causing variation could be the behaviour of the posterior spinal ligaments. Perhaps there is an optimum degree of flexion that will allow increased rotation. Beyond this point a tightening of the posterior soft tissues, such as the supra and interspinous ligaments along with the fibrous capsules of the zygapophysial joints themselves, may result in an inhibited rotational capacity. There is evidence in the literature that the interspinous ligaments only become tightened towards the extremes of flexion, being lax in the upright position (11), thus not restricting rotation until the most flexed postures.

It is now possible to discuss these results with reference to the aetiology of disc degeneration and prolapse.

Adams and Hutton (4) are of the opinion that torque is unimportant in disc damage because the rotational angles needed to damage annular fibres cannot be achieved due to the limiting effect of the compression

(Range)
(40-62)
(9-21)
(55-83)
(4-15)

Proc Instn Mech Engrs Vol 203

zygapophysial joint. However, they themselves point out that a loss of 3 mm of articular cartilage from the zygapophysial joint would lead to approximately 6° of extra motion at that joint. Torsion could, therefore, be envisaged to produce annular damage in a two-stage process. First repeated torsional trauma could be expected to lead to a thinning of articular cartilage giving rise to a greater ability of a joint to twist. This combined with the 5° or so of extra rotation available when acting in combination with flexion may be sufficient to cause annular damage. The conclusion of this study is that the lumbar spine has a greater rotational capacity in a flexed posture than when erect, implying that torsion may be a cause of injury to the intervertebral disc when combined with flexion.

REFERENCES

- 1 Farfan, H. F. *Mechanical disorders of the low back*, 1973, pp. 62–92 (Lea and Febiger, Publishers, Philadelphia).
- 2 Gregerson, G. G. and Lucas, D. B. An *in vivo* study of axial rotation of the human thoracolumbar spine. *J. Bone Jt Surg*, 1967, 49A, 247–262.
- 3 Pearcey, M. J. Stereo radiography of lumbar spin motion. *Acta Orthop. Scand.*, 1985, Suppl. 212, S6, 1–45.
- 4 Adams, M. A. and Hutton, W. C. The relevance of torsion to the mechanical derangement of the lumbar spine. *Spine*, 1981, 6, 241–248.
- 5 Liu, Y. K., Goel, V. K., Dejong, A., Njus, G., Nishiyama, K. and Buckwater, J. Torsional fatigue of lumbar intervertebral joints. *Spine*, 1985, 10, 894–900.
- 6 Shirazi-adi, A., Ahmed, A. M., and Shrivastava, S. C. Mechanical response of a lumbar motion segment in axial torque alone and combined with compression. *Spine*, 1986, 11, 914–927.
- 7 Kelly, S. Measurement of the lumbar spine—the evaluation of back care education. MSc thesis, University of Loughborough, England, 1985.
- 8 Pearcey, M. J., Gill, J. M., Whittle, M. W. and Johnson, G. R. Dynamic back movement measured using a three-dimensional television system. *J. Biomechanics*, 1987, 20, 943–949.
- 9 Pearcey, M. J., Gill, J. M., Johnson, G. R. and Hindle, R. J. Patterns of movement in the normal lumbar spine. Manipulative Therapists Association of Australia. *Proceedings of fifth biennial conference*, 1987, pp. 37–44.
- 10 Markolf, K. L. Deformation of the thoracolumbar intervertebral joint in response to external loads: a biomechanical study using autopsy material. *J. Bone Jt Surg.*, 1972, 54A, 511.
- 11 Silver, P. H. S. Direct observations of changes in tension in the supraspinous and interspinous ligaments during flexion and extension of the vertebral column. *J. Anat.*, 1954, 88, 550.

Instit Mech Engrs

New method for the non-invasive three-dimensional measurement of human back movement

M J Pearcy PhD, CEng, MBES

R J Hindle BSc

The Bioengineering Research Group, University of Durham, UK

Summary

A new method for the non-invasive three-dimensional measurement of human lumbar movement is described. The electro-magnetic 3SPACE Isotrak system was found to be accurate and reliable, having a total r.m.s. error for rotations of less than 0.2° . The system was able to produce consistent plots of subjects' movement patterns and it is proposed that this system should be evaluated in respect of its discriminatory and predictive potential in clinical studies of low back disorders. It may then become a useful tool in the routine clinical assessment of patients with spinal disorders, providing a complete quantification of back kinematics quickly and efficiently.

Relevance

The 3SPACE system may, for the first time, provide a means for the routine quantification of back kinematics in a clinical setting as a part of the assessment of patients with spinal disorders.

Keywords: Three-dimensional back movement, Electro-magnetic sensing device, Spine kinematics

Introduction

Clinicians often perform simple one and two-dimensional measurements of spinal motion when examining patients with back disorders as an adjunct to their own subjective assessment of the patients' movements. These simple techniques, such as the skin distension method for measuring lumbar flexion^{1,2}, are often unrepresentative of the actual movements of the spine and are of limited value in that they only record an index for the range of motion^{3,4}.

Other more sophisticated systems, such as biplanar radiography⁵, are able to give accurate measurements of spinal motion in three dimensions but suffer from the disadvantages of being time consuming and complicated, and have the inherent health risk of repeated X-ray exposure. Biplanar radiography is also unable to provide information about the kinematic patterns of movement, only measuring the end points of motion.

Systems that allow the quantification of kinematic movement patterns should, therefore, be of use in the assessment and diagnosis of spinal injury and disease.

Recent research has concentrated on the development of opto-electronic devices for the non-invasive measurement of spinal motion in three dimensions. Two such systems were recently assessed by Pearcy et al.⁶. Both the CODA-3 (Charnwood Dynamics Ltd, Loughborough, UK) and VICON (Oxford Metrics Ltd, Oxford, UK) systems were found to be less than ideal, both being rather too complex and time consuming to be suitable for a routine clinical role.

This article describes a new electro-magnetic system for the non-invasive three-dimensional measurement of spinal motion and presents the results of a study of the movements of ten normal male subjects.

The 3SPACE system

The 3SPACE Isotrak (Polhemus Navigation Sciences Division, McDonnell Douglas Electronics Company, P.O. Box 560, Colchester, Vermont 05446, USA) is an electro-magnetic device for the measurement of the position and orientation of a sensor in space⁷. It consists of an electronics package, containing the hardware to drive

Received: 23 August 1988

Accepted: 4 October 1988

Correspondence and reprint requests to: Dr MJ Pearcy, School of Engineering and Applied Science, University of Durham, Science Laboratories, South Road, Durham, DH1 3LE, UK

© 1989 Butterworth & Co (Publishers) Ltd
0268-0033/89/020073-07 \$03.00



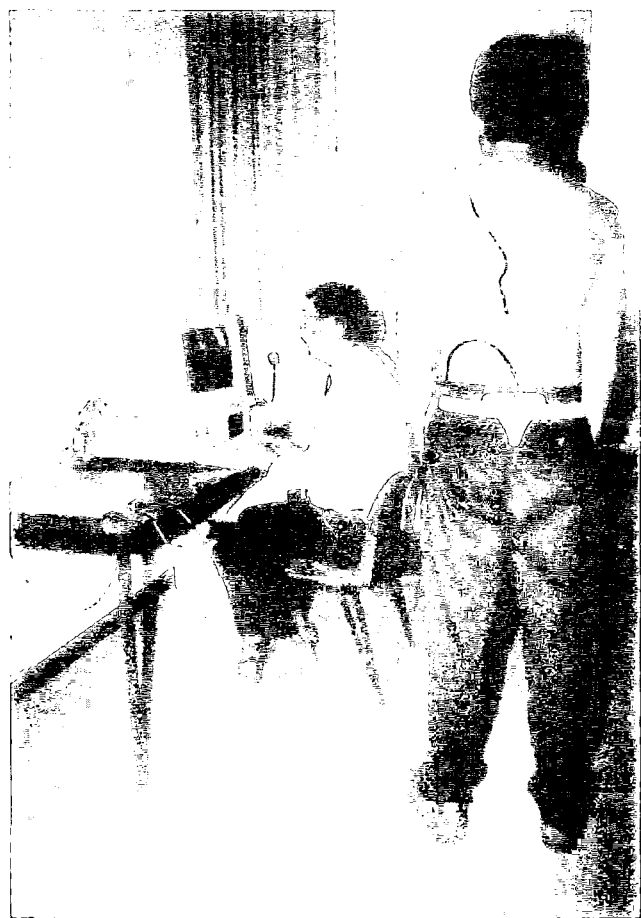

Figure 1. The 3SPACE Isotrak system. The source and sensor are in position over the sacrum and upper lumbar spine of a subject and are connected to the electronics box which is, in turn, connected to the personal computer.

the system and the primary software for the control of data acquisition, to which are attached a source module and a sensor (Figure 1). The source generates a low-frequency magnetic field which is detected by the sensor. The sensor monitors the magnetic field and the electronics package calculates the position and orientation of the sensor relative to the source with the full 6 degrees of freedom for three dimensions. The electronics package is linked to a personal computer which controls the 3SPACE operation, data acquisition and data storage through specially written applications software.

Movements are obtained by comparing the output from the sensor at discrete time intervals controlled from the personal computer. For the measurement of back movements, at this preliminary stage, rotations alone are measured and so the data acquired from the 3SPACE at each time interval consists of the 3×3 matrix of direction cosines for the orientation of the sensor relative to the source. This matrix is then analysed to give three independent rotations of the back relative to the pelvis based on the definitions of flexion/extension, lateral bending and axial rotation (or twisting) according to the method of Percy et al.⁸, which is a modification of that proposed by Benati et al.⁹. Back movements are quoted as rotations from the relaxed upright position to provide a standard starting point.

Specification of the system

Resolution

The reliability of the 3SPACE system was assessed by mounting the source and sensor securely on a solid wooden beam at approximately the same distance they would be apart when mounted over the sacrum and the first lumbar vertebra, respectively. Wood was used, since the 3SPACE system relies on a magnetic effect and any mass of metal in close proximity may affect its accuracy. Data were recorded over a 10-second period, this being repeated five times. The root mean square (r.m.s.) variation for each of the three movement planes (flexion/extension, lateral bend and axial rotation) for each of the five trials was $< 0.05^\circ$. This represents the 3SPACE system error.

The procedure was repeated while the beam, to which the source and sensor were mounted, was moved randomly in space. The system error increased slightly but remained $< 0.1^\circ$.

Accuracy

To assess the accuracy with which the 3SPACE system measures a known angle, four wooden wedges of different inclination had their angles measured by the 3SPACE system and by a precision optical clinometer. The clinometer was capable of measuring an angle to within 5 seconds of arc.

Each wedge was, in turn, secured to a wooden base to which was also attached the source. Data were collected from the 3SPACE system, first with the sensor on the flat base to establish the zero position, then with it placed on the angled surface of the wedge. This was repeated five times for each wedge. The clinometer was then employed to determine the true inclination of each wedge, the final value being an average of three readings. The results were as displayed in Table 1.

Table 1. Results of the trials to determine the accuracy of the 3SPACE system

Wedge	Mean clinometer reading ($^\circ$)	Mean 3SPACE reading ($^\circ$)	Error ($^\circ$)
1	8.674	7.649	-1.025
2	18.045	16.694	-1.346
3	26.852	25.019	-1.833
4	34.572	32.165	-2.408

Regression analysis showed that accuracy reduces linearly as the angle increases according to the equation:

$$y = 1.056x + 0.509$$

where y = true angle and x = 3SPACE reading.

Repeatability

The repeatability of measurement of the 3SPACE system was assessed using a specially constructed wooden rig

Table 2. The repeatability of measurement of the 3SPACE system

Movement	R.m.s error (°)
Flexion-extension	0.079
Lateral bend	0.127
Axial rotation	0.066

consisting of a hinged beam mounted vertically on a flat base. The source was mounted on one arm of the hinged beam and the sensor on the other. The two halves of the beam were then rotated relative to each other, by a set angle, about the hinge; the source and sensor being mounted in such a way that this represented movement in the flexion/extension plane. This was repeated three times. The procedure was then carried out twice more, with the source and sensor positioned such that lateral bend and axial rotation were simulated. The results are displayed in Table 2. A mean r.m.s. error of 0.091° was obtained, which was of the same order as the system error. These trials indicated that the total r.m.s. error encountered in measuring angles with this device was less than 0.2°.

These studies were conducted with uniplanar movement. To assess the repeatability of the measurements when rotations occurred in more than one plane, these tests were repeated with the sensor additionally rotated in a plane other than that under examination. The results showed that the accuracy of measurement in each plane was not affected by rotations in the other planes.

Preliminary subject trials

A study was made of the movements of 10 male subjects in order to establish if the 3SPACE system could effectively determine the ranges and patterns of lumbar motion.

All subjects were physically fit and had experienced no back pain in the 6 months previous to the study; none had ever undergone spinal surgery. The mean age of subjects was 34.1 years (range 22–49 years).

To determine lumbar motion the source was mounted over the sacrum and the sensor over the spinous process of L₁. The source was secured to a moulded plastic pad that was contoured to sit over the sacrum, and was held in place by a strap secured around the subject's pelvis. The spinous process of L₁ was identified by palpation and the sensor attached to the skin overlying it by means of double-sided tape and a strap around the body; this arrangement was found to be the best at reducing the effect of skin distension. Figure 2 shows the source and sensor in place on a subject.

Each subject performed three movements; maximal flexion then extension, lateral bend to left and right and axial rotation to left and right. Each movement was performed over a 10-second period and was repeated three times. Data were collected at a frequency of 10 Hz, this

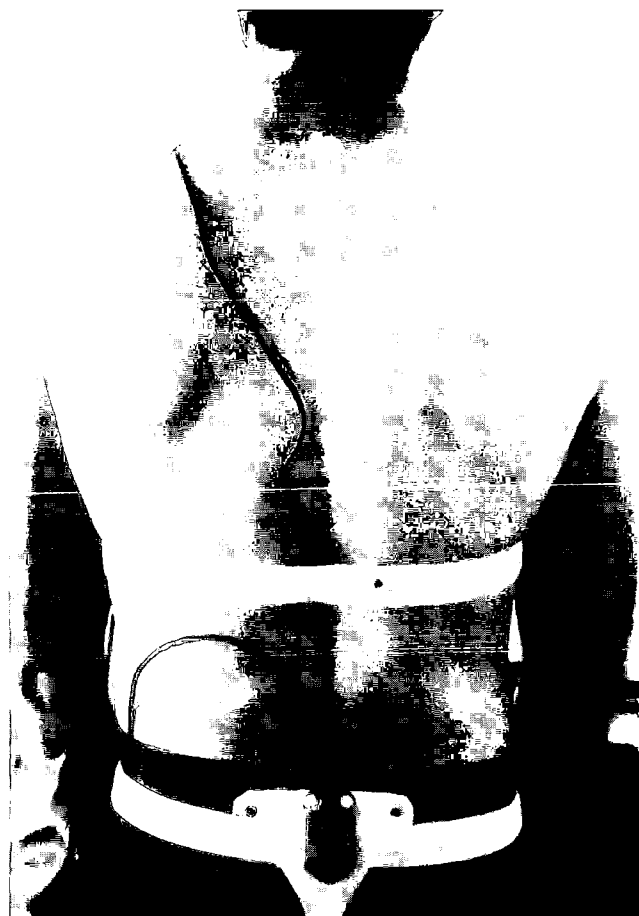

Figure 2. The source and sensor mounted on a subject over the sacrum and upper lumbar spine, respectively.

having been found adequate in previous studies for the measurement of these relatively slow movements^{6,8}. The whole process, from explaining the procedure to the subject to completing the data analysis, took approximately 45 minutes. In practice, actual patient contact time separate from analysis can be reduced to as little as 10 minutes.

Results

The raw data were only corrected using the regression equation when rotations were to be quoted in degrees, as in the range of movement. Graphically presented data were not corrected, to facilitate their production from the raw data as quickly as possible. Each subject's maximum movement for each trial was used to compile the mean results for all ten subjects. These are displayed in Table 3.

Table 4 presents the results obtained from this study for maximal flexion and extension, lateral bend and axial rotation alongside the definitive indices of lumbar spinal motion determined by Pearcy using biplanar radiography⁵.

Figures 3, 4 and 5 show composite plots of all 10 subject's patterns of movement while performing flexion/extension, lateral bend and axial rotation, respectively.

Table 3. The mean, maximal movements displayed by all ten subjects. (True movement calculated from the regression equation found in the determination of the system accuracy)

	Maximum movement (°)		
	Measured	True	s.d.
Flexion	71.1	75.6	9.9
Extension	21.3	23.0	4.3
Total	93.4	99.1	8.1
Right bend	26.5	28.5	6.3
Left bend	25.9	27.9	5.9
Total	52.4	55.8	8.4
Right twist	14.1	15.4	6.3
Left twist	14.7	16.0	3.3
Total	28.6	30.7	7.2

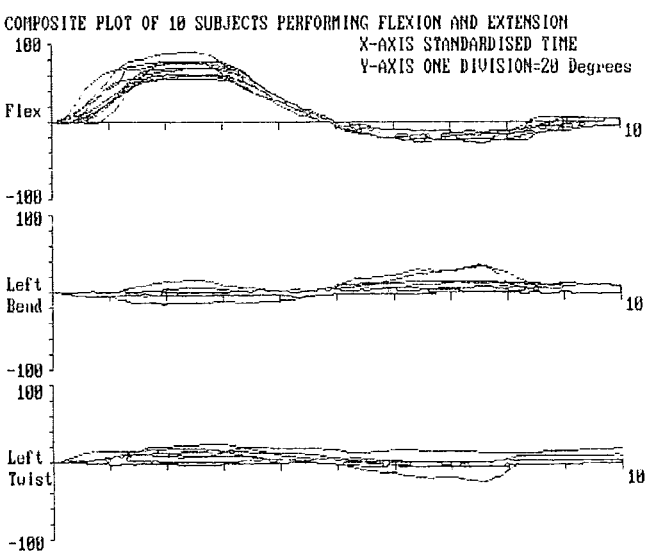

Figure 3. Composite plots of the 10 subjects performing flexion/extension.

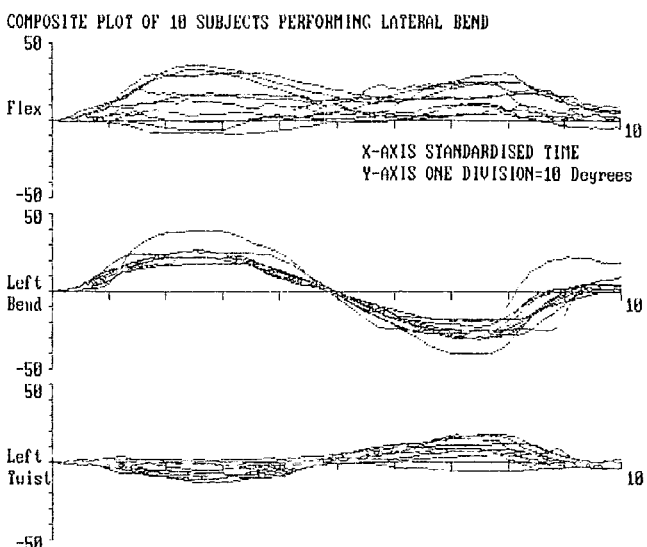

Figure 4. Composite plots of the 10 subjects performing lateral bend.

Table 4. Measurement of maximal flexion-extension, lateral bend and axial rotation by the 3SPACE system in comparison with biplanar radiographic measurement of the same movements⁵

Movement	Measured (°)	True (°)	3-D X-ray (°)
Flexion-extension	93.4	99.1	67
Lateral bend	52.4	55.8	35
Axial rotation	28.6	30.7	8

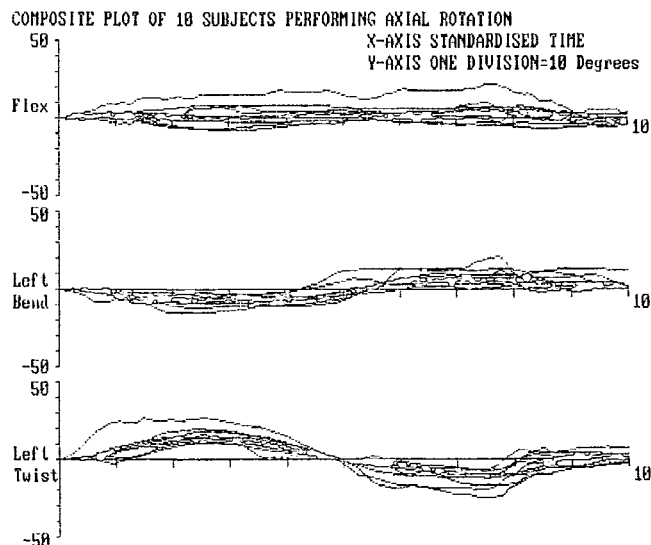

Figure 5. Composite plots of the 10 subjects performing axial rotation (or twisting).

These plots have been normalized (or scaled) so that the maximum and minimum values of the primary movement occur at 25 and 75% of the time period, respectively, and the point of sign change between these two occurs at 50% of the time interval. For each primary movement the accompanying movements have been normalized using the scaling required for the primary movement.

Figure 3 shows that during flexion and extension some small movements of lateral bending and axial rotation occurred but with no overall pattern. Figure 4 shows that lateral bending was accompanied by twisting in the opposite direction, except for one subject who exhibited right twisting during right bending. There was also a marked tendency for flexion to occur during bending to left and right. Figure 5 shows that twisting was accompanied by lateral bending in the opposite direction, except for one subject who exhibited right bending during right twisting. Some flexion or extension was also seen but with no overall pattern.

Discussion

The 3SPACE system presented a number of attractions that warranted its investigation as a possible clinical tool, these being its ease of use, its ability to record kinematic movement and its relative low cost; being at

most a tenth of the cost of opto-electronic devices currently on the market.

The 3SPACE system has been shown to be both accurate and reliable, having a total r.m.s. error of less than 0.2° . However, as can be seen from Table 3, the system does overestimate true lumbar spinal motion. Any system that attempts to quantify lumbar spinal motion by measuring the movement of a marker or sensing device attached to the overlying skin will suffer from the movement of soft tissues disguising the true vertebral motion. In order to reduce the effect of these overlying tissues, it was found necessary to place a strap over the sensor and around the subject. Originally the sensor was attached at L₁ with double-sided tape alone. Its position was not significantly displaced during flexion/extension or lateral bending; however, during twisting it was discovered that the skin was drawn markedly across the back, displacing the transducer from the centre line. The effect of this

was to cause erroneous values of rotation to be recorded. This displacement of the sensor was eliminated by use of the strap. Inevitably, this will have led to movement being introduced from higher up the spine. Location of the source over the sacrum using a moulded plastic pad was found to be very effective; very little or no movement was detected between the source and pelvis in all subjects.

Despite the difference in the magnitude of movement detected by the 3SPACE system compared to biplanar radiographic measurements of spinal movements, the patterns of movement displayed in Figures 3, 4 and 5 agree well with previous work. Due to the complex three-dimensional structure of the lumbar spine a movement in any one plane is always accompanied by some movement in the other two planes. Pearcy⁵ found that, at the end point of motion, axial rotation is accompanied by opposite lateral bend, for example right axial rotation

COMPOSITE PLOT OF ONE SUBJECT PERFORMING FLEXION AND EXTENSION THREE TIMES
X-AXIS STANDARDISED TIME
Y-AXIS ONE DIVISION=20 Degrees

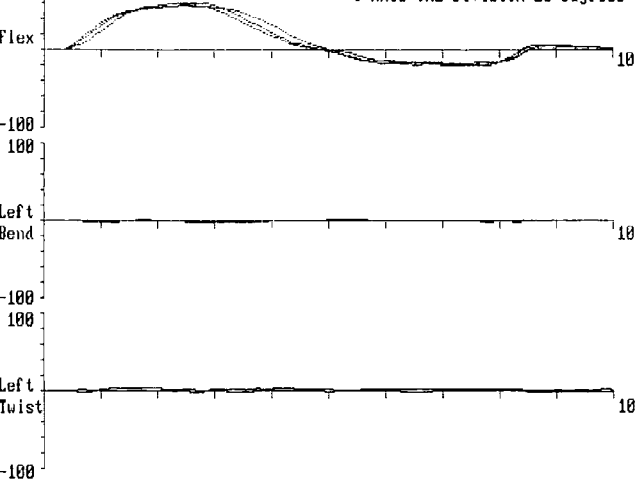

a

COMPOSITE PLOT OF ONE SUBJECT PERFORMING LATERAL BEND THREE TIMES
X-AXIS STANDARDISED TIME
Y-AXIS ONE DIVISION=10 Degrees

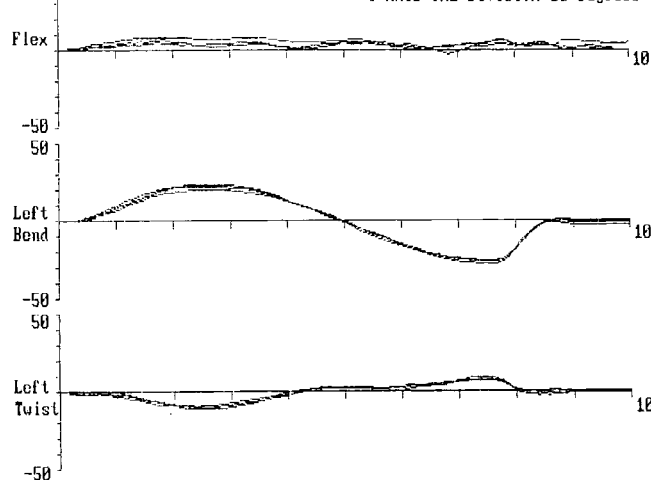

b

COMPOSITE PLOT OF ONE SUBJECT PERFORMING AXIAL ROTATION THREE TIMES
X-AXIS STANDARDISED TIME
Y-AXIS ONE DIVISION=10 Degrees

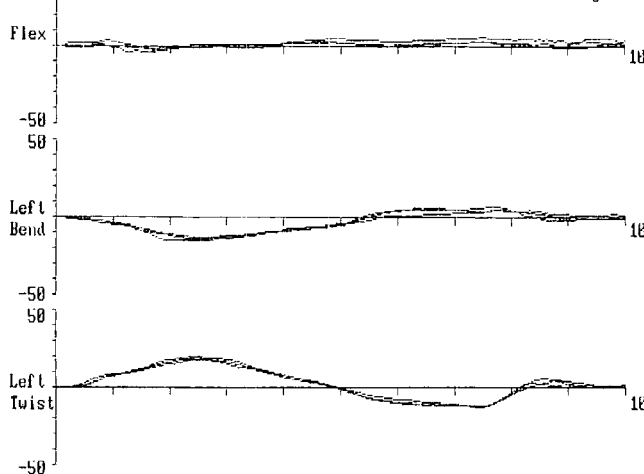

c

Figure 6.a Composite plots of subject A repeating flexion/extension three times. **b** Composite plots of subject A repeating lateral bend three times. **c** Composite plots of subject A repeating axial rotation three times.

is accompanied by left lateral bend and *vice versa*. Conversely, lateral bend is accompanied by an opposite axial rotation. This system not only demonstrated these patterns at the extremes of movement but also quantified the whole kinematic pattern.

As can be seen from Figures 3, 4 and 5, these patterns of movement were very consistent between subjects, although there was wide variation in the ranges of movement. These comparisons were facilitated by normalizing the graphs to take account of the different rates at which individuals performed the manoeuvres. Compilation of the graphs of raw data produced plots with barely discernable patterns. The normalization was shown to be a valid technique by the production of distinguishable 'signature' plots by each individual. Figures 6 and 7 show the consistency of repeated movements by two of the subjects.

Future assessment of the patterns of movement of patients suffering from known pathological conditions in comparison with the movements of injury-free subjects may lead to specific movement disorders being linked to specific pathologies and hence a possible diagnostic role for this system in respect of low back syndromes. A data base of normal subjects is now being collected in a continuation of the subject study presented here.

The characteristic 'signature' movements shown to be displayed consistently by individual subjects point to another possible clinical role for the system; the 3SPACE system could be used to follow a patient's recovery during a treatment regime or after spinal surgery as part of routine clinical assessment.

As mentioned in the Introduction, it is more likely that a system that can effectively determine the patterns of movement rather than just the position of the spine at

COMPOSITE PLOT OF ONE SUBJECT PERFORMING FLEXION AND EXTENSION THREE TIMES
X-AXIS STANDARDISED TIME
Y-AXIS ONE DIVISION=20 Degrees

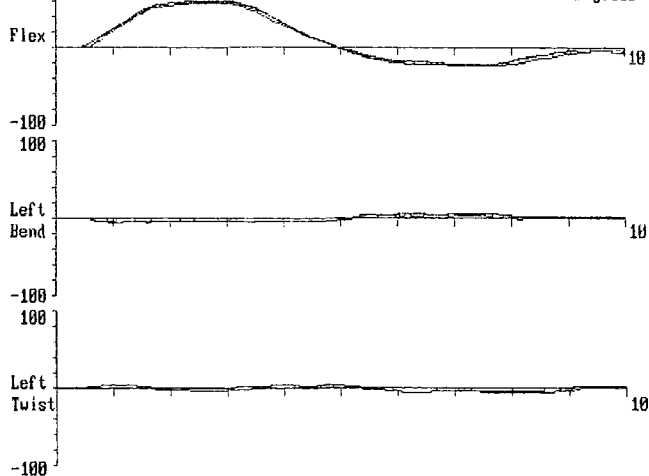

a

COMPOSITE PLOT OF ONE SUBJECT PERFORMING LATERAL BEND THREE TIMES
X-AXIS STANDARDISED TIME
Y-AXIS ONE DIVISION=10 Degrees

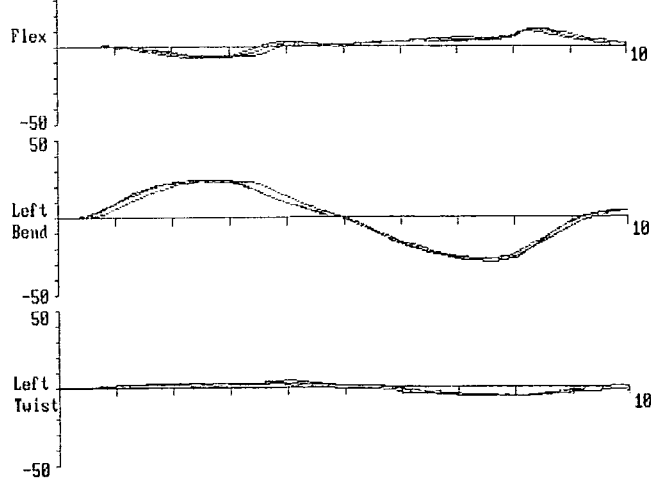

b

COMPOSITE PLOT OF ONE SUBJECT PERFORMING AXIAL ROTATION THREE TIMES
X-AXIS STANDARDISED TIME
Y-AXIS ONE DIVISION=10 Degrees

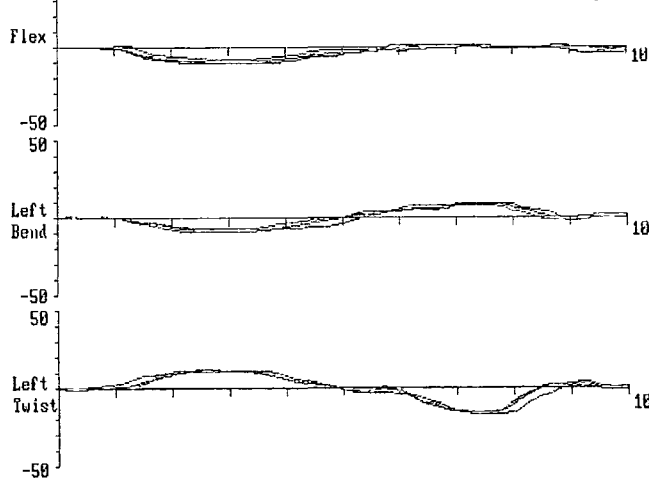

c

Figure 7. a Composite plots of subject B repeating flexion/extension three times. b Composite plots of subject B repeating lateral bend three times. c Composite plots of subject B repeating axial rotation three times.

the extremes of motion will be of use clinically. It has been shown that the 3SPACE system can perform this role quickly and efficiently.

References

- 1 Schober P. Lendenwirbelsaule und krenzschemerzen. *Munch Med Wschr* 1937; 84: 336–8
- 2 Macrae IF, Wright V. Measurement of back movement. *Ann Rheum Dis* 1969; 28: 584–9
- 3 Portek I, Pearcy MJ, Reader GP, Mowat AG. Correlation between radiographic and clinical measurement of lumbar spine motion. *Br J Rheumatol* 1983; 22: 197–205
- 4 Pearcy MJ. Measurement of back and spinal mobility. *Clin Biomech* 1986; 1: 44–51
- 5 Pearcy MJ. Stereo radiography of lumbar spine motion. *Acta Orthop Scand* 1985; 56: 212
- 6 Pearcy MJ, Gill JM, Hindle RJ, Johnson GR. Measurement of human back movement in three dimensions by opto-electronic devices. *Clin Biomech* 1987; 2: 199–204
- 7 An KN, Jacobsen MC, Berglund LJ, Chao EYS. Application of a magnetic tracking device to kinesiologic studies. *J Biomech* 1988; 21: 613–20
- 8 Pearcy MJ, Gill JM, Whittle MW, Johnson GR. Dynamic back movement measured using a three-dimensional television system. *J Biomech* 1987; 20: 943
- 9 Benati M, Goglio S, Morasoo P, Tagliascr V, Zaccarin R. Anthropometric robotics I. Representing mechanical complexity. *Biol Cybernet* 1980; 38: 125–40

Posterior element variation at the thoracolumbar transition: a morphometric study using computed tomography

K P Singer DipPT, MSc
P D Breidahl* MD, FRCR, FRACR
R E Day* BE

The University of Western Australia, Nedlands, and *The Royal Perth Hospital, Perth, Australia

Summary

Variation in posterior element orientation at the thoracolumbar junction was investigated using computed tomography. The study population ($n = 630$) aged from 10 to 93 years, comprised 551 abdominal scans, 26 thoracolumbar junction scans and 53 cadaveric spines. Scans of T_{10-11} , T_{11-12} , T_{12-L_1} and L_{1-2} zygapophyseal joints were selected, with joint orientation calculated using a computer-aided digitizer. In 59.6% of cases the change from coronal to sagittal joint orientation was achieved gradually over three levels between T_{10-11} to T_{12-L_1} . This progressive transitional pattern was identified between T_{9-10} to T_{11-12} in 0.5% and between T_{11-12} to L_{1-2} in 11.4%. An abrupt transition between T_{11-12} and T_{12-L_1} occurred in 18.1% of cases, with 10.2% at $T_{10-11}-T_{11-12}$ and 0.2% at T_{12-L_1} to L_{1-2} . Zygapophyseal joint asymmetry ($>10^\circ$) was most frequent at T_{11-12} (40.8%), followed by T_{12-L_1} (17.7%). Ossification anomalies of the L_1 transverse processes were demonstrated in 2.06% of cases.

Relevance

This study reports the incidence of asymmetry in posterior element orientation and variations in the level of the thoracolumbar transition from a large asymptomatic population. This database provides the clinician with an anatomical reference when investigating this highly variable region of the vertebral column. Biomechanical modelling of spinal motion will be improved through recognition of the variations in zygapophyseal joint morphology present at the thoracolumbar junction.

Keywords: Thoracolumbar transition, zygapophyseal joint orientation, tropism, anatomical variants

Introduction

Of the transitional regions of the human spine, the thoracolumbar (T-L) junction is the most inconsistent in terms of location and it is further characterized by morphological variants and frequency of serious injury¹. Anatomical descriptions of this region suggest that the transition from coronal to sagittal plane orientation of

the zygapophyseal (facet) joints occurs predominantly between T_{11-12} and T_{12-L_1} ²⁻⁵. However, variations in the transitional level and joint geometry at this region have been reported⁶⁻⁸ and much of this data has been derived from qualitative anthropometric and radiographic studies⁹⁻¹¹. Typically, the transition has been recorded as the level where the articular processes adopt lumbar (sagittal) characteristics⁹.

To consider variations in structural morphology of the T-L junction, quantitative data for the T_{10-L_2} vertebral segments were obtained from a survey of routine CT cases and scans of cadaveric spines. This paper reports variations in the level and type of transition and patterns of zygapophyseal joint orientations that were encountered from 630 cases.

Submitted: 21 September 1988

Accepted: 30 November 1988

Correspondence and reprint requests to: Kevin P. Singer, Department of Anatomy and Human Biology, The University of Western Australia, Nedlands WA 6009, Australia

© 1989 Butterworth & Co (Publishers) Ltd
0268-0033/89/020080-07 \$03.00

Measurement of human back movements in three dimensions by opto-electronic devices

M J Pearcy, PhD, MBES

J M Gill* PhD, MBES, R J Hindle, BSc, G R Johnson* PhD, MBES

Bioengineering Research Group, School of Engineering and Applied Science, University of Durham and *Department of Mechanical Engineering, University of Newcastle upon Tyne, UK

Summary

Two systems for the measurement of the movement of retro-reflective markers in three-dimensional space have been used to measure rotations of the human back. Both the CODA-3 and the VICON devices used are available commercially. Both devices were shown to be capable of producing reproducible data on three-dimensional rotations. However, neither system was shown to be ideal due to the difficulty of maintaining the markers in the field of view. In particular, the CODA-3 system was found to be severely limited in this application due to the problem of cross-over conflict between the retro-reflective prisms that results in the loss of data. The VICON system was found to be more flexible but data analysis requires an interactive input from the operator and so can be very time consuming.

Relevance

The non-invasive measurement of dynamic back movement will provide clinicians with objective data to assess whether alterations to patterns of movement are of assistance in the diagnosis of back pain. The assessment of techniques to provide these data is the first stage in the development of a tool for clinical use.

Key words: Three-dimensional movements, Human back, Opto-electronic devices

Introduction

Back movement is investigated clinically to assess alteration to the range or pattern of movement caused by injury or disease. This generally involves a subjective analysis by the clinician watching the patient move, often supported by simple one-dimensional measurements of range of movement to enable some quantifiable index to be recorded. This may involve the measurement of skin distraction over the lumbar spine^{1,2} or angular measurements with pendulum goniometers^{3,4}. More sophisticated techniques are less easy to use in a clinic, take longer, are more expensive and, perhaps most importantly, have not yet been shown to provide information that is any more useful than that provided by the simple techniques.

A recent article⁵ reviews the techniques available for measuring back movement and points out the present lack of a suitable system to measure the dynamic three-

dimensional movements of the back which would allow the subjective observations of the clinician to be quantified. If these observations were made objective and hence quantifiable, it should then prove possible to define the relation between altered movements and injury or disease and hence assist the diagnosis and treatment of back disorders.

The recent development of computerized, opto-electronic systems for the measurement of the position of markers in three-dimensional space allows movements to be measured in real time. This article describes the use of two such systems to measure three-dimensional rotations of the human back and highlights their advantages and failings.

Measurement systems

The two systems used, a CODA-3 machine (Movement Techniques Ltd, UK) and a VICON system (Oxford Metrics Ltd, UK), are both available commercially. Details of the manufacturers of both systems are given in the appendix.

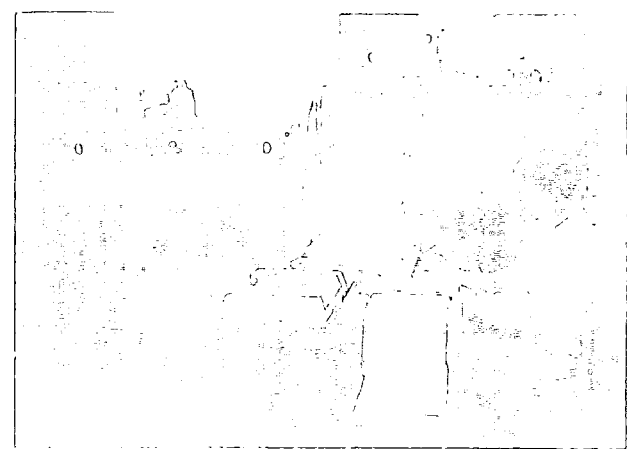

Figure 1. The CODA-3 machine (left), its dedicated computer, and operator (right).

CODA-3 (Figure 1) is an optical scanning device that sends out three fan-shaped beams of light, producing a rectangular cone shaped field of view, to retro-reflective prisms attached to a subject. The light is sent out via three octagonal, synchronized rotating mirrors, two mounted on vertical axles 1 metre apart, the third on a horizontal axle between the two. The reflected light returns to the mirrors and is detected by light sensitive sensors. The orientation of the mirrors when the reflected light is detected enables the position of a prism to be calculated by simple geometry; a routine calibration procedure is not required. The orientation of the mirrors rotating about the vertical axles gives the position of the retro-reflective prism in a horizontal plane, the orientation of the third mirror about its horizontal axle gives the vertical height of this plane in relation to a datum defined by the machine. In this way the instantaneous three-dimensional positions of a

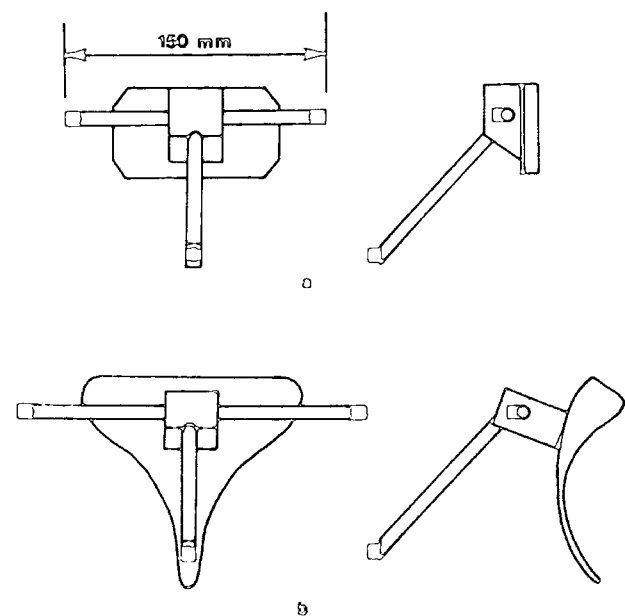

Figure 2. Scale drawing of the marker rigs for the VICON system. (a) spinal rig, (b) sacral rig.

Table. Comparison of the CODA-3 system used in this study, the latest CODA-3 model and VICON

	CODA-3	NEW CODA-3	VICON
Requirement for routine calibration	NO	NO	YES
Maximum number of prisms or markers	6	12	30
Crossover conflict	YES	NO	NO
Automatic prism or marker identification	YES	YES	NO
360° field of view	NO	NO	YES
Real time data output	YES	YES	NO

prism are calculated. In addition, the prisms have colour filters cemented to their faces, so colour coding the reflected light. This allows the machine to discriminate the positions of several prisms at the same time. The machine used at Newcastle has the ability to discriminate six prisms consistently. The principal failing of this machine's ability to detect the position of the prisms is that if any two prisms come within approximately 25 mm of each other in the horizontal or vertical directions then they cannot be discriminated from each other; they are said to be in conflict and are considered to be out of view so that the data are lost until they move apart. The consequences of this failing are detailed further below.

The VICON system used was that at the Oxford Orthopaedic Engineering Centre and is described in detail elsewhere⁶. In brief, the system consists of stroboscopic lights mounted on video cameras with the scanning of the video tubes synchronized with the lights. Small markers covered in retro-reflective tape are attached to the subject and light from each stroboscope is reflected back to the associated camera. A calibration procedure is required prior to testing so that the position of the detected light on the video tubes can be used to calculate the position of the markers in space. For this to be possible, each marker must be in the view of at least two cameras at any instant.

This system has no automatic discrimination of the markers, and so once the data have been collected the two-dimensional paths of the markers from each camera are viewed on a screen and each marker manually identified. The computer can then automatically track the paths of the markers in the view of each camera and, when this is complete, combine the data from two cameras to calculate the three-dimensional coordinates. When the trajectories of two markers cross in the two-dimensional views the computer may lose the identification, but this can be reallocated manually. This procedure can be slow and laborious but few data are lost.



Figure 3. CODA-3 prism mounting plates on a subject.

A comparison of the two systems is summarized in the Table together with specifications of the most recent CODA-3 model which is detailed further in the discussion.

Back movement measurement

Using either system individual prisms or markers attached to a subject's back with double-sided tape can be traced through three-dimensional space as the subject moves, provided that the prisms or markers stay within the field of view of the machine and are not obstructed by other parts of the body. A further limitation of the CODA-3 system used for this study is that the prisms must not come into conflict with each other. This limitation prohibits the positioning of the prisms in convenient, geometric configurations, as any two prisms on the same horizontal or vertical line will be in conflict, or if positioned close to such lines will come into conflict after only a small movement of the subject. This problem was tackled by Kelly,⁷ who positioned the prisms in asymmetric patterns on the backs of subjects. Vectors joining the prisms were calculated and the analysis then considered projections of these vectors in horizontal and vertical planes of reference to obtain angles of rotation. However, attaching the prisms or markers directly to the surface of the back has the disadvantage that any skin deformation during movement would alter the orientation of the vectors between the prisms, so introducing error into the calculated

angles. Further, although the projection of vectors onto three orthogonal planes gives angles of rotation around three axes these angles are not independent. This problem of defining three-dimensional rotations is discussed in a recent well-written review by Andrews⁸.

In order to define the full three-dimensional rotations of body segments it is necessary to define a reference plane attached to each segment. The relative orientation of these planes, calculated as the subject moves, then provides truly three-dimensional rotation data. A detailed explanation of the mathematical analysis to calculate the three-dimensional rotations is presented elsewhere⁹.

The definition of a plane requires three known points and for this plane to be defined consistently as the subject moves the relative orientation of the three points must remain unaltered. To do this three prisms or markers are mounted on a rigid former or plate which can then be attached to the back of the subject (Figure 2). The measurement of lumbar spine movement requires one marker rig to be attached over the sacrum, with a second over the lumbar spine at the level of the L1 spinous process. For these studies the marker rigs were mounted on pieces of polyethylene foam moulded to conform to the contours of the body. Double-sided tape was used to fix the foam to the skin, together with straps around the pelvis and trunk.

With the CODA-3 system used for this investigation the prisms must be positioned to reduce both intra- and inter-rig conflict as the subject moves, resulting in the use of more cumbersome rigs than required with the VICON system (Figure 3). The positioning of the prisms on each rigid plate should be optimum if they form an equilateral triangle. Ideally this would allow rotations about an axis perpendicular to the plate of 15° either side of a central position before two markers were on the same vertical or horizontal line. However, conflict occurs when two prisms come within approximately 25 mm of these lines and rotations about the other orthogonal axes will have components about the axis perpendicular to the plate, so reducing the permissible rotations. In practice it has been found that no more than $5-10^\circ$ of rotation in the plane of the plate can be tolerated, depending on the extent of the other rotations. Also, idiosyncracies in the detection of the reflected light have resulted in the prisms being positioned out of the equilateral geometry depending on the movement being attempted by the subject (Figure 3).

The limitations imposed on the rotations by this CODA-3 system are such that only very simple manoeuvres of the back can be measured. A pilot study has shown that flexion/extension and twisting can be measured reproducibly¹⁰. However, this could be achieved only if the pelvis was restrained by a standing frame or by the subject being seated to limit movement of the reflective prisms relative to the CODA-3 scanner in order to overcome the problem of conflict and to keep the prisms in the field of view.

A preliminary study with the VICON system, using

only two video cameras, demonstrated that more complex movements could be measured,⁹ but these were still limited by markers moving out of the field of view or being obstructed by other parts of the body. However, again by using a standing frame which limited the movements of the pelvis reproducible and consistent results were obtained.

Measurement procedures

The accuracy of rotation measurement for both systems was assessed by mounting the two marker rigs on a tripod such that one rig could be rotated relative to the other through known angles. A sampling frequency of 10 Hz was used with both systems as this was found to be adequate to study the relatively slow movements of the back, and the data were collected during a 10-second period. The following calibration tests were performed with the tripod:

1. The tripod was left unaltered for the whole measurement period to assess the inherent system error.
2. One rig was rotated relative to the other through known angles about each of three orthogonal axes to assess the accuracy of rotation measurement.

The results of these tests were similar for both systems.

1. The system errors gave a maximum range of $\pm 2^\circ$ for rotations about any axis with a root mean square error of $< 1^\circ$.
2. The errors in the calculated angles were within the system error of $\pm 2^\circ$.

Thus both systems were shown to be able to measure rotations to within $\pm 2^\circ$.

Studies on healthy volunteers have demonstrated that both systems are capable of producing repeatable patterns of back movement^{9,10}. Examples of the movements measured by the CODA-3 and VICON systems for two different subjects are shown in Figures 4 and 5, respectively.

Discussion

The applicability of the CODA-3 system to the measurement of three-dimensional body segment rotations was found to be limited by the occurrence of conflict between the prisms. No experimental procedure can eliminate this problem, as it is an inherent failing of the machine. However, the manufacturer's specifications for the most recent models indicate that the problem of conflict has been addressed and the situation improved. A new instrument was demonstrated to one of the authors (MJP) and no data loss through cross-over conflict could be detected (see Table). The earlier system would be more appropriate for examining movements occurring in any plane in three-dimensional space using widely spaced prisms; for example, in gait analysis, with prisms on the hip, knee and ankle, the angle of knee flexion could be measured¹¹. In addition, since CODA-3 has a fixed base dimension of 1 metre, movements have to be performed within a restricted field of view. The main advantage of the CODA-3 system is the convenience of immediate, real-time, three-dimensional data output and the need for only infrequent calibration.

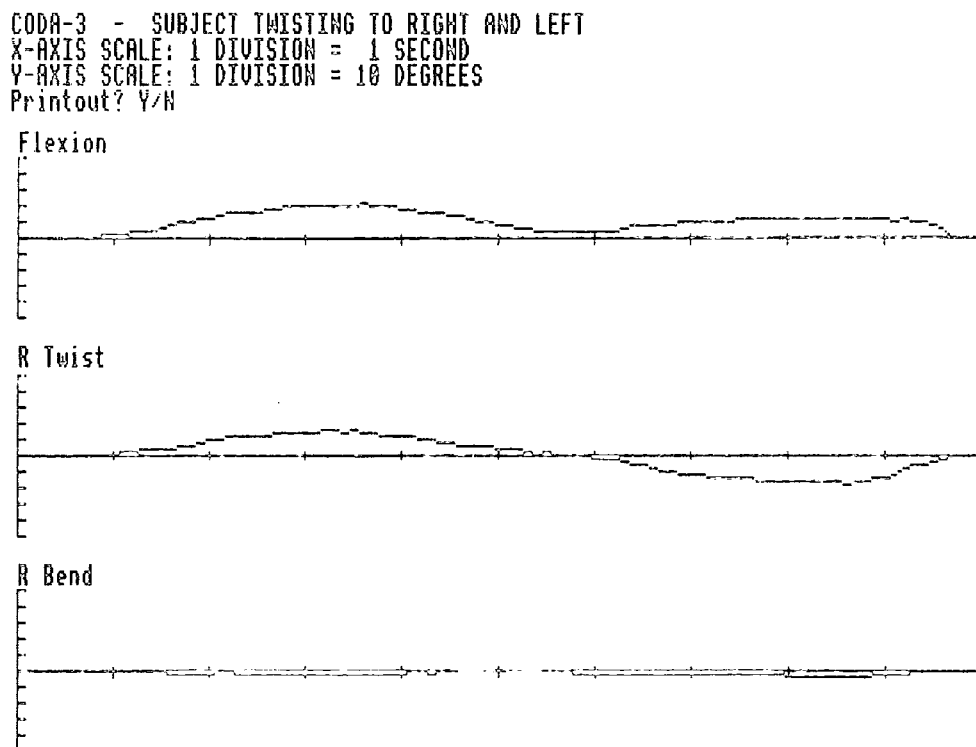

Figure 4. A typical plot of angles of flexion/extension, twist and lateral bend against time as a subject twisted whilst standing, measured by CODA-3.

The use of the VICON system was found to be limited if movements were large so that markers became obscured. However, it is possible to use three or even four cameras together rather than just two, giving a full 360° field of view, and then, as long as a marker stays in view of two cameras, its movements can be traced. Use of more cameras would also remove the requirement for the standing frame and allow movements to be performed freely. Analysis is laborious, since manual input is required to identify the markers. This can pose problems if two markers stay close to one another, and the identification of six or more markers (VICON has the capacity to view up to 30 markers) for three or four cameras would be a lengthy process. However, because the identification can be checked and reallocated if markers do cross, this system is flexible and can be used to measure many more types of movement.

The problem of attributing movements to the underlying skeleton from measurements of markers mounted on the body surface requires discussion. It has been demonstrated clearly that surface markers move relative to the bones (see, for example Stokes¹² and Towle¹¹). The studies using the marker rigs described here^{9,10} produced some ranges of movement larger than those recognized for spinal movement¹³, implying that other than pure spinal movement was recorded. These systems must by the nature of the attachment of the markers include soft tissue movements and thus measure back rather than spinal movement, but the dynamic patterns of movement seen may be of value. The non-invasive measurement of physiologic move-

ment is possible only with this type of system at present. The patterns seen with the VICON system were very similar at the extremes of movement to those of three-dimensional radiographic studies¹³, indicating a relation to the movements of the spine, while those found with the CODA-3 system were not as similar¹⁴. This is probably attributable to the more cumbersome rigs required for the CODA-3 system, which may have introduced some artefacts into the measurements, and would account, together with individual variation, for the differences between Figures 4 and 5. In addition, there is the problem of identifying the bony landmarks over which the marker rigs are attached. With the sacral rig this was found to pose no problem, as the double-sided tape together with the strap around the pelvis effectively coupled the rig to the pelvis, there being no discernable movement of the rig relative to the pelvis during the manoeuvres performed here. The rig positioned over L1 was also held on with a strap around the trunk and so some rib cage and thoracic spine movements must have been included in the measurements. However, placement of the rig to within 10 mm vertically on the back had no effect on the results. It can be seen, therefore, that these systems provide a means of measuring dynamic three-dimensional body segment movements but not those of isolated spinal elements.

Systems that detect individual markers in space are not ideal for the measurement of three-dimensional rotations because three markers in rigid conformation are required to define planes, leading to two main problems. The first is the necessity for cumbersome

```
VICON - SUBJECT TWISTING TO RIGHT AND LEFT
X-AXIS SCALE: 1 DIVISION = 1 SECOND
Y-AXIS SCALE: 1 DIVISION = 10 DEGREES
Printout? Y/N
```

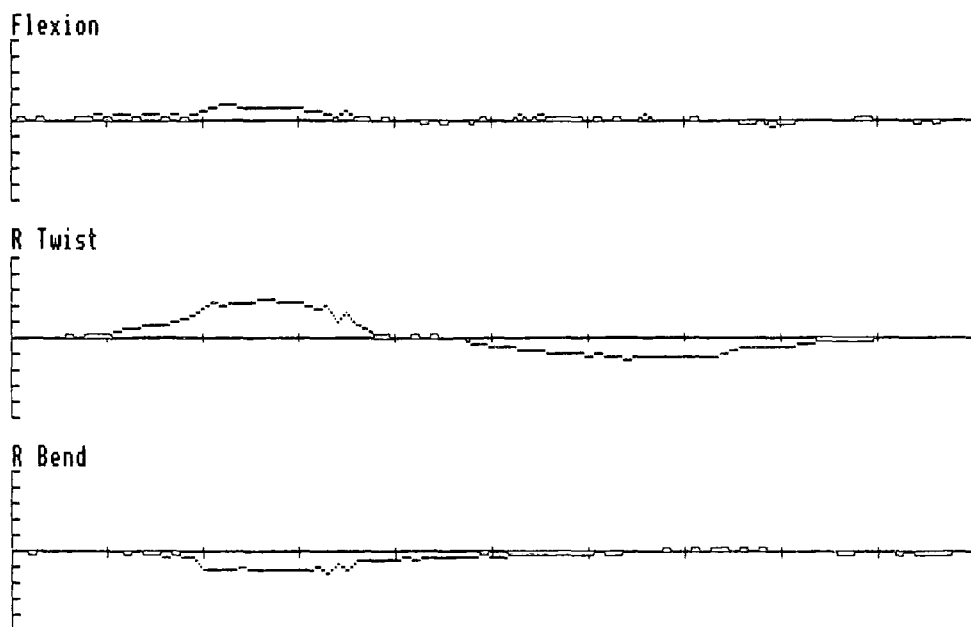

Figure 5. A typical plot of angles of flexion/extension, twist and lateral bend against time as a subject twisted whilst standing, measured by the VICON system.

mounting rigs which have to be attached to the subject. The second is that small changes in relatively large dimensions are then required to be measured accurately in order that the rotations of the planes can be calculated. Thus these systems may be regarded as suitable for the measurement of two-dimensional movements occurring in three-dimensional space but not for three-dimensional movements.

Finally, both systems described here are sophisticated and require skilled operation to obtain repeatable results. This, together with the time required for markers to be attached to the subject, the movements to be performed and the results analysed, militates against their use as routine clinical tools.

Conclusion

The use of marker based systems for three-dimensional movement analysis is limited, due to the requirement to define planes attached to each body segment from the coordinates of three markers. Because of their complex nature these systems are unlikely ever to become clinical tools. For research the VICON system appears the more applicable because of its flexibility, while CODA-3 with its automatic identification of the reflective prisms may be suitable for particular tasks such as the assessment of two-dimensional lower and upper limb angles during walking and running. As far as the measurement of rotational movements of the human back is concerned, although both systems were shown to be capable of producing reproducible and consistent data, neither CODA-3 nor VICON was found to be ideal.

Acknowledgements

We wish to thank Dr MW Whittle of the Oxford Orthopaedic Engineering Centre, without whom the subject trials using the VICON system could not have been performed. This work was facilitated by the Science and Engineering Research Council grant GR/D/48858.

References

- 1 Schober P. Lendenwirbelsaule und Krenschmerzen. Munch Med Wschr 1937; 84: 336-8
- 2 Macrae IF, Wright V. Measurement of back movement. Ann Rheum Dis 1969; 28: 584-9
- 3 Asmussen E, Heeboll-Nielsen K. Posture, mobility and strength of the back in boys, 7 to 16 years old. Acta Orthop Scand 1959; 28: 174-89
- 4 Loebl WY. Measurement of spinal posture and range of spinal movements. Ann Phys Med 1967; 9: 103-10
- 5 Percy MJ. Measurement of back and spinal mobility. Clin Biomech 1986; 1: 44-51
- 6 Whittle MW. Calibration and performance of a three-dimensional television system for kinematic analysis. J Biomech 1982; 15: 185-96
- 7 Kelly S. Measurement of the lumbar spine—the evaluation of back care education. MSc Thesis 1985, University of Loughborough, UK
- 8 Andrews JG. On the specification of joint configuration and motions. J Biomech 1984; 17: 155-8
- 9 Percy MJ, Gill JM, Whittle MW, Johnson GR. Dynamic back movement measured using a three-dimensional television system. J Biomech 1987 (in press)
- 10 Hindle RJ, Percy MJ, Gill JM, Johnson GR. The ability of the human back to twist in various degrees of forward flexion. Presented at the annual meeting of the International Society for the Study of the Lumbar Spine in Rome, May 1987
- 11 Towle JA. The precise measurement of knee joint kinematics as an aid in clinical assessment. Clin Biomech 1986; 1: 214-5
- 12 Stokes IAF. Relationships between movements of vertebrae and adjacent skin markers and sections of the back. Annual Report No. 4, 1977, Oxford Orthopaedic Engineering Centre, Headington, Oxford, UK pp 41-3
- 13 Percy MJ. Stereo radiography of lumbar spine motion. Acta Orthop Scand 1985; Vol 56, supplement 212
- 14 Hindle RJ. The three-dimensional measurement of lumbar spinal motions and their involvement in spinal injury. Progress Report, 1987. School of Engineering and Applied Science, University of Durham, UK

Appendix

CODA-3

Manufacturer: Movement Techniques Limited,
Unit 5, The Technology Centre,
Epinal Way,
Loughborough,
Leicestershire LE11 0QE,
UK

VICON

Manufacturer: Oxford Metrics Limited,
Unit 8,
7 Westway,
Botley,
Oxford OX2 0JB,
UK

Rotational mobility of the human back in forward flexion

R.J. Hindle and M.J. Pearcy

The Bioengineering Research Group, University of Durham, Science Laboratories, South Road, Durham, DH1 3LE, UK

Presented at the 28th Annual Scientific Meeting of the Biological Engineering Society, Salford, UK, 7-9 September 1988

ABSTRACT

This paper describes the measurement of the ability of the human back to twist when in flexed postures using a new electromagnetic measurement device. The mobility of the lumbar spine in 12 normal male subjects was investigated and it was demonstrated that increased rotation was possible when in a flexed posture. This suggests that the intervertebral disc may be vulnerable to torsion when twisting is combined with sub-maximal sagittal flexion.

Keywords: Lumbar spine mobility, axial rotation, electromagnetic sensing device, intervertebral disc injury

INTRODUCTION

There is considerable controversy in the literature concerning the role of torsion in the production of intervertebral disc degeneration and prolapse. Farfan and colleagues¹ believe torsion to be the most important factor in the initiation of annular damage. They have produced annular ruptures similar to those that occur *in vivo* by subjecting intervertebral joints to forced rotations. They found that an average of 22.6° was required to produce failure in whole joints with normal discs. They stated that the neural arches and zygapophysial processes became distorted to permit this rotation and maintained that the normal whole joint failed without gross damage to the bone of either the vertebral body of zygapophysial joint.

The normal physiological ranges of axial rotation for the lumbar spine have been determined by Pearcy² using biplanar radiography. This gave a figure of 8-10° of axial rotation for the whole lumbar spine, or approximately 2° per joint. It would seem, therefore, that under ordinary circumstances it is impossible for an intervertebral disc to fail as a result of rotation. However, Farfan¹ maintained that any joint rotated to more than 3.5° must receive some injury to the disc.

More recent research has produced contrary evidence. Adams and Hutton³, for example, believe torsion to be unimportant in the production of disc degeneration and prolapse. As a result of their experiments they concluded that torsion is primarily resisted by the zygapophysial joint that is in compression and that this is the first structure to yield at the limit of torsion, said to occur after 1-2° of

rotation. They also stated that at the point where the zygapophysial joints are damaged, the disc is only rotated to between one-tenth and one-third of its maximum angle and bears only a small fraction of the torque required to rupture it.

Liu *et al.*⁴ investigated the effect of cyclic torsional loading on intervertebral joints. They also concluded that torsion was unimportant in the initiation of disc degeneration and prolapse, but added that as degeneration progresses, torsion contributes to joint instability.

Shirazi-adl *et al.*⁵ constructed an extensive finite element model of an L2-3 motion segment. As a result of their analysis they concluded that torque alone cannot cause the failure of disc fibres but that it could enhance the vulnerability of the posterior and posterolateral fibres when acting in combination with other types of loading such as occur in flexion.

An examination of the morphology of the lumbar intervertebral joints in relation to their mechanics indicates that the lumbar zygapophysial joints are shaped such that during flexion, when they become distracted, an increase in rotational ability may well result. This mechanism is illustrated in *Figure 1*.

A recent paper addressed the role of torsion, when acting in combination with forward flexion, in the production of intervertebral disc injury⁶. It used a three-dimensional opto-electronic system to determine if subjects could twist more when in a state of forward flexion, because normal amounts of axial rotation seem to be insufficient to cause injury to the intervertebral disc. Results did indicate that this was the case. However, the CODA-3 system used had severe operational limitations and therefore there was an element of doubt concerning the reliability of data⁷. It was decided to repeat the trial using a new electromagnetic system, the 3SPACE Isotrak.



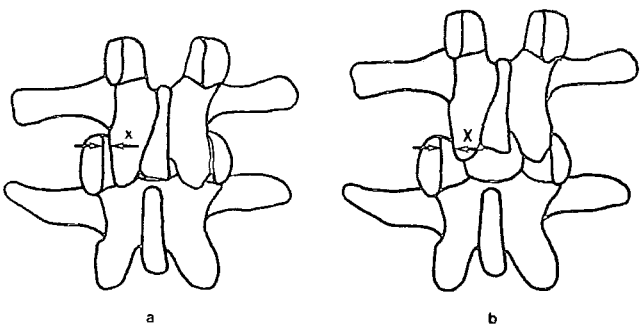

Figure 1 Posterior view of a lumbar intervertebral joint twisted so that the zygapophysial joint faces on the right are in contact. **a**, In the erect position; **b**, in the flexed position, the zygapophysial joint faces on the left are separated by a greater distance ($X > x$) indicating a larger twist

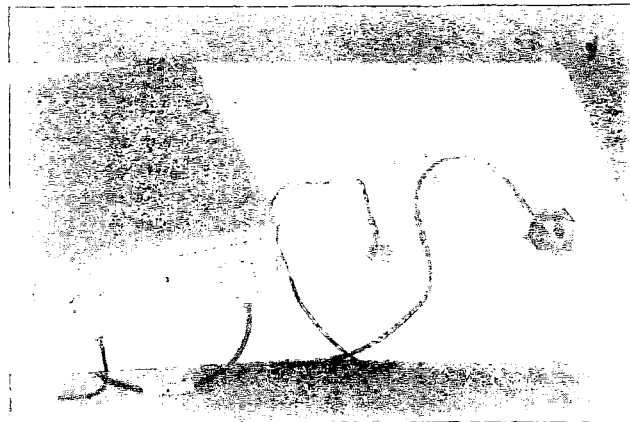

Figure 2 The 3SPACE Isotrak system

METHODS

The 3SPACE system

The 3SPACE Isotrak (Polhemus Navigation Sciences Division, McDonnell Douglas Electronics Company, PO Box 560, Colchester, Vermont, USA) is an electromagnetic sensing device for the measurement of the position and orientation of a sensor in space. It consists of an electronics package, containing the hardware to drive the system and the primary software for the control of data acquisition, to which a source module and a sensor are attached (Figure 2). The source generates a low-frequency magnetic field which is detected by the sensor. The sensor monitors the magnetic field. The electronics package calculates the position and orientation of the sensor relative to the source with the full six degrees of freedom for three-dimensions. The electronics package is linked to a personal computer which controls the 3SPACE operation, data acquisition and data storage through specially written applications software.

Movements are obtained by comparing the output from the sensor at discrete time intervals controlled from the personal computer. For the measurement of back movements the 3×3 matrix of direction cosines for the orientation of the sensor relative to the source is obtained at each time interval. This matrix is used to give the three independent angles of flexion/extension, lateral bend and axial rotation according to the method of Pearcy *et al.*⁸. Further details of the system may be found in a recent publication⁹.

To determine lumbar motion the source is mounted over the sacrum and the sensor over the spinous process of L-1. The source is secured to a moulded plastic pad that is contoured to sit over the sacrum. It is held in place by a strap secured around the subject's pelvis. The sensor is attached to the skin directly overlying the spinous process of L-1 by means of double sided tape and a strap around the body. Figure 3 shows the source and sensor in position on a subject.

The 3SPACE system has already shown itself to be readily capable of measuring back movement and quantifying back kinematics. It is both accurate and



Figure 3 The source and sensor attached to a subject

reliable and has a total r.m.s. error for rotations of approximately 0.20 (ref 9).

Subject trials

Twelve physically fit male subjects participated in the study. None had experienced any back pain in the six months previous to the study or undergone spinal surgery. The mean age of subjects was 33 years (range 22–45 years).

After the source and sensor had been mounted, each subject first performed maximal flexion and

extension. Subjects were encouraged to perform each movement as far as was possible. Subjects were then asked to perform maximal axial rotation (or twisting) in three different postures. Maximum voluntary standing axial rotation was measured first. Subjects crossed their arms over their chests and twisted as far as was possible to the right then to the left in the 10 s measurement period. This was repeated three times.

Maximum voluntary axial rotation was then assessed in two seated postures that were intended to induce a certain degree of sagittal flexion. In the first the subject was seated on a stool with his knees flexed. In order to define the amount of flexion that occurred in the seated posture subjects began the trial in a standing position, they then sat down at the start of the measurement period and, once seated, twisted maximally, as before, to right and then left. The second seated posture required the subject, upon sitting down, to raise his legs onto another stool so that his knees were now extended. Twisting was performed as before.

RESULTS

The two seated postures were found to increase significantly the subjects' sagittal flexion from the normal standing position. Taking the subjects' standing posture as zero flexion and maximum flexion as that value achieved in the previous determination of the ranges of flexion and extension then the first posture induced, on average, some 35% of the subjects' maximum flexion. The second seated posture induced around 65% of maximum flexion. It was found that expressing the amount of flexion as a percentage of maximum, rather than absolute angular values, helped reduce the considerable individual variation present.

Figures 4, 5 and 6 show typical plots of a subject performing axial rotation while standing and in the two seated postures, respectively. Figure 4 shows the characteristic opposite lateral bend associated with

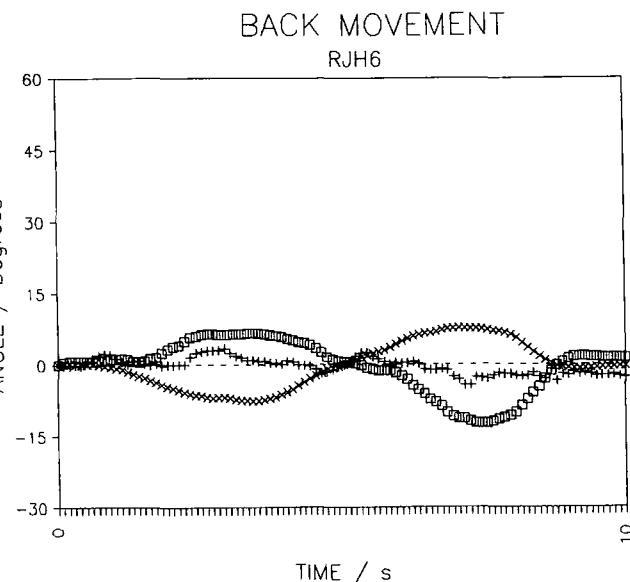

Figure 4 The movements of a subject performing axial rotation whilst standing; +, flexion; □, bend +ve L; ×, twist +ve L

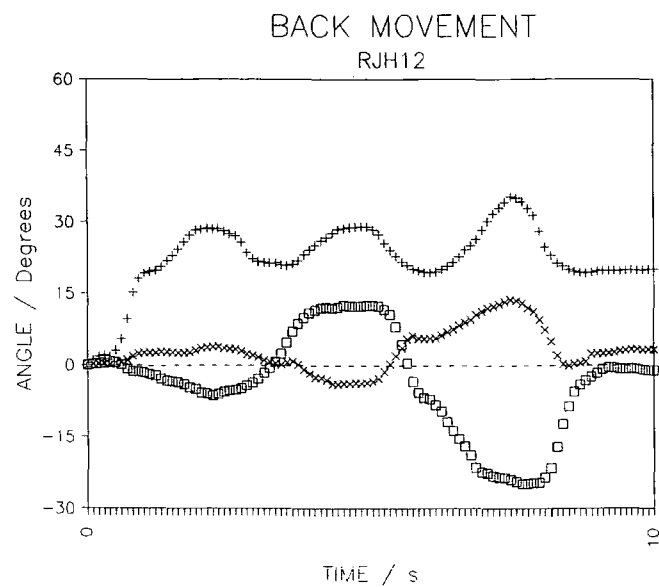

Figure 5 The movements of a subject performing axial rotation whilst sitting; +, flexion; □, bend +ve L; ×, twist +ve L

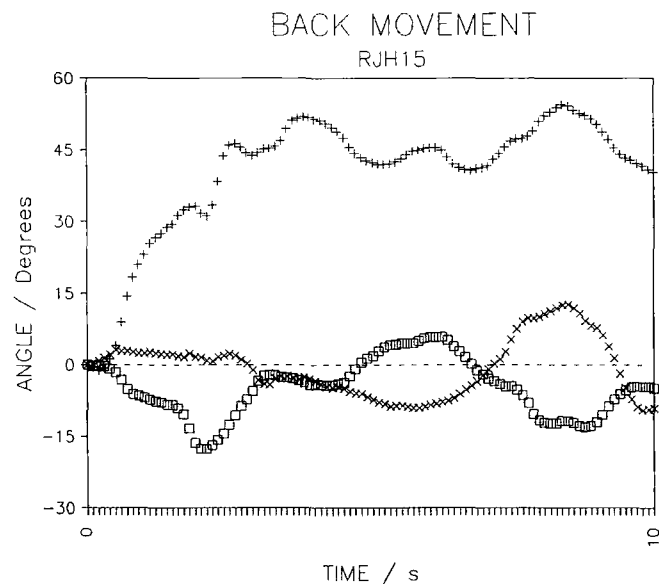

Figure 6 The movements of a subject performing axial rotation whilst sitting flexed +, flexion; □, bend +ve L; ×, twist +ve L

axial rotation⁹. Figures 5 and 6 show clearly the considerable flexion that each of the two seated postures induced.

An increase in maximum voluntary axial rotation was seen to occur in both of the two flexed postures (Figure 7). The largest value for axial rotation was observed in the first seated posture and this was found to be a significant increase from the standing value ($P < 0.01$, Paired t -test). Maximum axial rotation was also significantly higher than the standing value in the second, more flexed posture, but at a reduced confidence level ($P < 0.05$, Paired t -test).

The results for each individual are shown in Figure 8 which indicates the large variation both in amounts of twisting exhibited and the extent to which the sitting postures induced flexion of the lumbar spine.

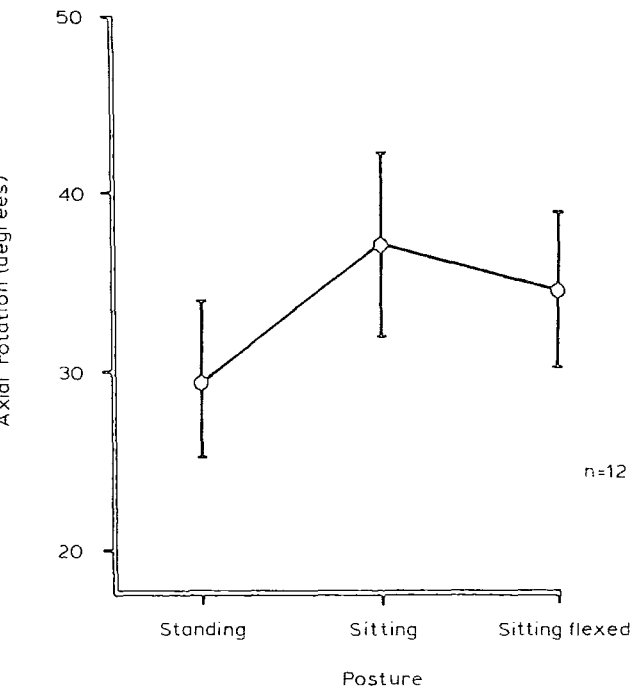

Figure 7 The maximum voluntary axial rotation obtained in the three postures marked with standard deviations across the means

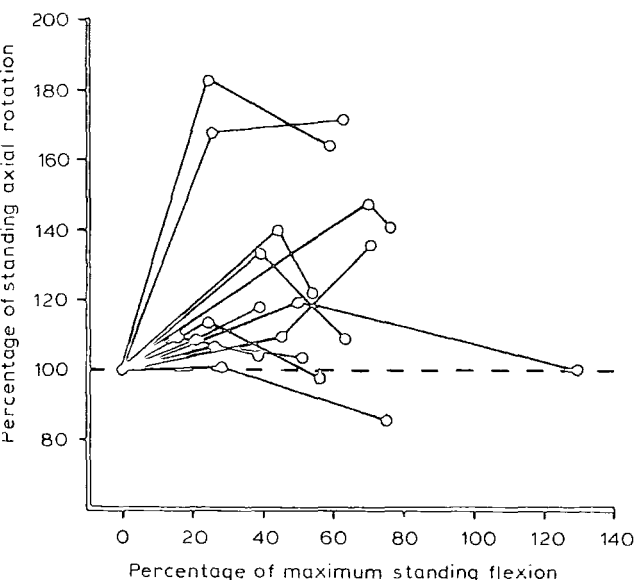

Figure 8 Percentage of standing axial rotation plotted against the percentage of flexion in the standing position, in each posture, for all subjects

DISCUSSION

A previous study using this system has examined its ability to measure both patterns and ranges of lumbar spinal motion of subjects performing flexion/extension, lateral bend and axial rotation⁹. It showed that the 3SPACE system is capable of determining accurately the patterns of motion but that it consistently overestimated true lumbar spinal mobility. It was concluded that this was due to the strap that was placed over the sensor and around the over chest, to try and negate the effect of skin

distension, which undoubtedly introduced movement from higher up the spine⁹. However, comparison of values between and within subjects is acceptable.

The mean value of standing axial rotation obtained was 29.4°, approximately three times the value one would expect for the whole lumbar spine. In some individuals an increase of up to 20° was observed when in the first seated posture. The majority of this increase can be attributed to increased mobility of the lumbar spine because the orientation of the thoracic zygapophysial joints is such that, even in the upright position, almost unhindered rotation is available. Even if they are removed torsional stiffness is almost unchanged¹⁰. Therefore, in some individuals an extra 3–4° of rotation may be available at each lumbar joint when the spine is flexed.

Gregerson and Lucas¹¹ measured the movement of Steinman pins inserted into lumbar spinous processes of volunteers whilst performing axial rotation standing and in a seated posture. They noted a slight decrease in the rotation possible in the seated posture. However, they attempted to maintain a 90° thigh-trunk angle in their subjects. This would have maintained the lumbar lordosis so locking the zygapophysial joints together. This was not the case in this study where flexion was shown to increase in both the seated postures.

The orientation of the facets in the lumbar zygapophysial joints is subject to individual variation and this fact helps to explain the considerable variation seen with respect to patterns of flexion and rotation. Subjects with acutely orientated facets in their zygapophysial joints would require considerably more flexion to produce an increase in rotational ability than others, with more oblique facets, who would require only small amounts of flexion to show an increase in axial rotation. *Figure 8* shows this individual variation. Unfortunately it was not possible to examine radiographically the morphology of the zygapophysial joints in the subjects.

Figure 7 demonstrates that axial rotation actually fell slightly in the second, most flexed, seated posture. It would seem, therefore, that there is some 'optimum' degree of sagittal flexion that will permit increased rotation. Beyond this point a tightening of the posterior soft tissues such as the supra and interspinous ligaments, along with the capsules of the zygapophysial joints themselves, may lead to a reduction in the ability of the joint to twist. There is some evidence that these ligaments become tense only in the extremes of flexion, acting as end stops¹².

CONCLUSIONS

The results of our trial agree with the similar work undertaken with the optoelectronic CODA-3 system⁶. It can be concluded that some degree of sagittal flexion does permit greater axial rotation to occur.

Adams and Hutton¹ are of the opinion that torque is unimportant in the production of disc damage because the rotational angles required to initiate damage to annular fibres cannot be achieved due to

the limiting effect of the zygapophysial joint in compression. However, they themselves point out that a loss of 3 mm of articular cartilage from the zygapophysial joint could permit up to 6° of extra rotation at that joint. Repeated torsional trauma could be expected to lead to a thinning of the articular cartilage. This, combined with the extra rotation available when the spine is flexed, may be sufficient to cause annular damage. Thus, the conclusion of our study is to confirm that the lumbar spine has a greater rotational capacity in a flexed posture than when erect. This implies that the intervertebral disc may be vulnerable to torsion when twisting is combined with forward flexion.

REFERENCES

1. Farfan HF. *Mechanical Disorders of the Low Back*. Philadelphia: Lea and Febiger, 1973: 62-92.
2. Pearcy MJ. Stereo radiography of lumbar spine motion. *Acta Orthop Scand Suppl* 212 1985; **56**
3. Adams MA, Hutton WC. The relevance of torsion to the mechanical derangement of the lumbar spine. *Spine* 1981; **6**: 241-8.
4. Liu YK, Goel VK, Dejong A, Nijus G, Nishiyana K, Buckwater J. Torsional fatigue of lumbar intervertebral joints. *Spine* 1985; **10**: 894-900.
5. Shirazi-adl A, Ahmed AM, Shrivastava SC. Mechanical response of a lumbar motion segment in axial torque alone and combined with compression. *Spine* 1986; **11**: 914-27.
6. Hindle RJ, Pearcy MJ, Gill JM, Johnson GR. Twisting of the human back in forward flexion. *J Eng Med* in press.
7. Pearcy MJ, Gill JM, Hindle RJ, Johnson GR. Measurement of human back movement in three dimensions by opto-electronic devices. *Clin Biomech* 1987; **2**: 195-204.
8. Pearcy MJ, Gill JM, Whittle MW, Johnson GR. Dynamic back movement measured using a three-dimensional television system. *J. Biomech* 1987; **20**: 943-9.
9. Pearcy MJ, Hindle RJ. A new method for the non-invasive three-dimensional measurement of human back movement. *Clin Biomech*, in press.
10. Markolf KL. Deformation of the thoracolumbar intervertebral joint in response to external loads: a biomechanical study using autopsy material. *J Bone Jt Surg* 1972; **54A**: 511-33
11. Gregerson GG, Lucas DB. An *in vivo* study of axial rotation of the human thoracolumbar spine. *J Bone Jt Surg* 1967; **49A**: 247-62.
12. Silver PHS. Direct observations of changes of tension in the supraspinous and inter-spinous ligament during flexion and extension of the vertebral column. *J Anat* 1954; **88**: 550-1

Spine kinematics: a digital videofluoroscopic technique

A.C. Breen*, R. Allen† and A. Morris‡

* Anglo-European College of Chiropractic, 13-15 Parkwood Road, Bournemouth, Dorset BH5 2DF, UK; † Department of Mechanical Engineering, The University, Highfield Southampton SO9 5NH, UK; ‡ Radiology Department, Odstock Hospital, Salisbury, Wiltshire SP2 8BJ, UK

Presented at the 28th Annual Scientific Meeting of the Biological Engineering Society, Salford, UK, 7-9 September 1988

ABSTRACT

It is notoriously difficult to quantify the kinematic behaviour of vertebral segments in the assessment and localization of mechanical disorders of the spine. This paper describes the use of an image processor and an X-ray machine with image intensifier for the measurement of lumbar spine angular rotation and instantaneous centres of rotation in the coronal plane. The system was calibrated against a model under realistic conditions employing multiplanar motion and X-ray scatter.

Keywords: Kinematics, spine, back pain, image processing

INTRODUCTION

The mechanical integrity of the spine is reflected in the movement between individual vertebral segments. Disruption of these intersegmental movements has been shown to occur as a result of both injury and degenerative change¹⁻⁶. Because the movements are small, and because any analysis of regularity depends on the measurement of increments over the total range, there are serious difficulties attached to attempts at clinical measurement. Nevertheless such measurement is necessary if comprehensive investigation of the mechanics associated with spinal pain and disability is to be undertaken.

The difficulties arise because measurement requires an imaging technique which allows the identification and accurate labelling of anatomical landmarks at increments in at least two dimensions, followed by mathematical calculation of the kinematics at individual levels from these data. Moreover, the measurements must not suffer from the effects of 'coupled motion', the tendency, especially with lateral bending in the lumbar spine, for axial rotation to accompany side bending⁷. Unfortunately the best-resolved images (with the exception of those generated by n.m.r., which is still impractical) are radiographic ones where some ionizing dosage is inevitable. This usually prohibits the acquisition of serial images, especially for screening and monitoring progress.

Measurement errors impose a further constraint on the development of such systems^{8,9} and calibration is seldom seen in the literature. Furthermore, the labour of carrying through calculations relating to multiple planes and levels requires sophisticated

computing techniques which have yet to be automated for this purpose.

We have previously described experiments with a digital videofluoroscopic system which offers prospects for overcoming these difficulties¹⁰. This system has been tested for its capacity to measure preset intervertebral angles in intensifier images of a calibration model. Other studies¹¹ have considered the effects of observer error, positional distortion and soft tissue scatter in relation to the accuracy of measurement of coronal and sagittal plane motion. This paper considers incremental motion in the coronal plane in terms of lumbar intervertebral angles and instantaneous centres of rotation (ICR) and the effects of coupled motion on the accuracy of measurement.

METHOD

The equipment included a Thompson CGR X-ray machine with image intensifier and a PDP11-based image processor (Kenda Electronic Systems Ltd) (*Figure 1*). Images from the intensifier were stored on videotape and subsequently digitized and stored on disk for study.

Using a calibration model (*Figure 2a*), seven intensifier images were obtained. The model consisted of a universal joint located at the disc centrum between two dry lumbar vertebrae and incorporated a mechanism for reliably pre-setting rotational angles in three planes. The settings represented equal increments of 5° of coronal plane rotation of the upper vertebra upon the lower. In order to impose the effects of coupled motion, 1° of axial rotation was added for every 2° of side bending in the model. In addition, 10 cm of animal soft tissue was positioned between the model and the X-ray source to simulate the effects of soft-tissue scatter in patients.

Correspondence and reprint requests to: Alan C. Breen