



## Durham E-Theses

---

### *In vitro studies on T cell proliferation and Lymphokine factor production in the amphibian, Xenopus*

Turner, Sarah Louise

#### How to cite:

---

Turner, Sarah Louise (1990) *In vitro studies on T cell proliferation and Lymphokine factor production in the amphibian, Xenopus*, Durham theses, Durham University. Available at Durham E-Theses Online: <http://etheses.dur.ac.uk/5957/>

#### Use policy

---

The full-text may be used and/or reproduced, and given to third parties in any format or medium, without prior permission or charge, for personal research or study, educational, or not-for-profit purposes provided that:

- a full bibliographic reference is made to the original source
- a [link](#) is made to the metadata record in Durham E-Theses
- the full-text is not changed in any way

The full-text must not be sold in any format or medium without the formal permission of the copyright holders.

Please consult the [full Durham E-Theses policy](#) for further details.

---

Academic Support Office, Durham University, University Office, Old Elvet, Durham DH1 3HP  
e-mail: [e-theses.admin@dur.ac.uk](mailto:e-theses.admin@dur.ac.uk) Tel: +44 0191 334 6107  
<http://etheses.dur.ac.uk>

*IN VITRO* STUDIES ON T CELL PROLIFERATION AND  
LYMPHOKINE FACTOR PRODUCTION IN THE  
AMPHIBIAN, *XENOPUS*

by

Sarah Louise Turner

July 1990

Thesis submitted to the University of Durham in the  
fulfilment of the requirements for the degree Doctor of  
Philosophy

The copyright of this thesis rests with the author.  
No quotation from it should be published without  
his prior written consent and information derived  
from it should be acknowledged.

## DECLARATION

No part of this thesis has been submitted in support of an application for any degree or qualification of the University of Durham, or any other University or Institute of learning.

I acknowledge the help of Claire Varley, with whom I collaborated, in a number of the mitogen experiments detailed in Chapter 3.

## ABSTRACT

The major aim of this Thesis has been to procure and begin to characterise T cell-derived cytokines in the clawed toad, *Xenopus*. Recent reports have suggested that *Xenopus* lymphocytes, stimulated *in vitro* with T cell mitogens, will generate factors that achieve the enhanced proliferation and growth of assay T lymphoblasts, but not unstimulated cells; these factors have been called 'T cell growth factors' and likened to mammalian interleukin-2. In this Thesis the nature of factors released in culture supernatants (SNs) by alloantigen- and mitogen-stimulation of *Xenopus* leucocytes is re-examined and it is shown that cells other than T lymphoblasts and even non-T cells are responsive to such T cell-derived 'lymphokines'.

Chapter 2 revealed that SNs collected from 48 hour cocultures of splenocytes from MHC (major histocompatibility complex)-disparate *Xenopus* were able to achieve enhanced proliferation not only of PHA-activated splenic lymphoid cells, but also of 'unstimulated' splenocytes. Thymic 'blasts', but not 'unstimulated' thymocytes, were also responsive to these mixed leucocyte culture (MLC)-induced factors.

In Chapter 3, to further investigate lymphokine production, splenocytes were stimulated with the T cell mitogens PHA (phytohaemagglutinin) and Con A (Concanavalin A) and the activity of the culture SNs then examined after mitogen removal. SNs taken at 24 hours achieved good

proliferation of both 'unstimulated' splenocytes and splenic blasts.

In Chapter 4, miniaturisation of the SN screening assay was successfully achieved, using only  $1.5 \times 10^4$  leucocytes in a 'hanging drop' culture, in order to minimise the amount of lymphokine required in an assay, and to allow experiments on few assay lymphocytes. It was shown that 'unstimulated' splenocytes from early-thymectomised *Xenopus* responded by proliferation to active supernatants (ASNs) (MLC-, PHA- or Con A-generated), indicating that a cell type other than a T cell could be induced to proliferate in the presence of ASN. Thymectomy experiments also indicated that T cells were necessary for the generation of active supernatants *in vitro*.

The identity of the thymus-independent cells responding to ASNs was further explored in Chapter 5. Using an anti-IgM monoclonal antibody, B cells from early-thymectomised *Xenopus* were separated from the rest of the splenocyte population by flow cytometry. Surface IgM<sup>+</sup> cells (B cells) responded mildly to ASNs, whereas the sIgM<sup>-</sup> population (and unsorted cells) responded well to both the PHA-ASN and the MLC-ASN.

Work carried out at the beginning of this Ph.D., that identified splenic antigen-presenting cells and (inconclusively) explored the rôle of these cells as stimulators in MLC responses in *Xenopus*, is reported in Chapter 6. The main conclusions to be drawn from this research are briefly discussed in Chapter 7 and

suggestions for future work considered.

## ACKNOWLEDGEMENTS

Firstly, I would like to thank my supervisor, Dr John Horton, for his invaluable help throughout the course of my studies, and particularly for his encouragement during the writing-up of this thesis.

My thanks also go to Pamela Ritchie, for her excellent technical assistance and frog-handling expertise, and to Trudy Horton, for her much appreciated help during expeditions to Newcastle University.

I am also very grateful to Brian Shenton for allowing me the use of the FACS at the Department of Surgery, University of Newcastle-upon-Tyne, and also to Alice Givan for operating the FACS.

Thanks go to all my family for their moral support, and especially Dad, for endless tea and biscuits! I also would like to thank John Weeds for his exceptional patience during the past three years.



## TABLE OF CONTENTS

|                   |     |
|-------------------|-----|
| Title page        | i   |
| Declaration       | ii  |
| Abstract          | iii |
| Acknowledgement   | vi  |
| Table of Contents | vii |
| List of Tables    | xiv |
| List of Figures   | xvi |
| Abbreviations     | xix |

### CHAPTER 1 Page

#### GENERAL INTRODUCTION

|       |                               |    |
|-------|-------------------------------|----|
| 1.1   | Immunology of <i>Xenopus</i>  | 1  |
| 1.2   | Lymphokines and interleukin-2 | 9  |
| 1.2.1 | Mammalian studies             | 9  |
| 1.2.2 | Comparative studies           | 12 |
| 1.3   | Purpose of thesis             | 19 |

### CHAPTER 2

#### MIXED LEUCOCYTE CULTURE IN *XENOPUS* AND THE PRODUCTION GROWTH FACTORS THROUGH ALLOANTIGEN STIMULATION

|       |  |    |
|-------|--|----|
| 2.1   | Introduction                               | 22 |
| 2.2   | Materials and methods                      | 27 |
| 2.2.1 | Animals                                    | 27 |
| 2.2.2 | Animal breeding and maintenance            | 28 |
| 2.2.3 | Preparation of leucocyte suspensions       | 29 |
| 2.2.4 | Media                                      | 30 |
| 2.2.5 | Skin grafting                              | 31 |
| 2.2.6 | MLC assays                                 | 31 |
| 2.2.7 | MLC-induced production of mitotic factors: |    |

|         |  |    |
|---------|--|----|
|         | proliferation assays   | 34 |
| 2.2.8   | Cell growth assay  | 36 |
| 2.2.9   | Thymocyte costimulation assay  | 37 |
| 2.2.10  | Statistics   | 37 |
| 2.3     | Results  | 38 |
| 2.3.1   | Kinetics of splenocyte one-way MLC in AL-15:BSA  | 38 |
| 2.3.2   | Inability of MLC-ASNs to costimulate one-way splenocyte MLCs   | 38 |
| 2.3.3   | Proliferative responses of splenic lymphoblasts to MLC-SNs   | 39 |
| 2.3.3.1 | Effect of dilution of MLC-SNs  | 39 |
| 2.3.3.2 | Kinetics of SN production in one-way MLC   | 39 |
| 2.3.3.3 | Experiments investigating the nature of assay blast cells  | 40 |
| 2.3.4   | Ability of one-way MLC-SNs to stimulate proliferation of both PHA-precultured and non PHA-treated spleen cells | 41 |
| 2.3.5   | Growth of splenocytes and blasts fed MLC-SNs   | 42 |
| 2.3.6   | Experiments to probe the inhibitory nature of CSNs   | 42 |
| 2.3.7   | Effect of prior skin grafting on splenocyte MLC-SN production  | 43 |
| 2.3.8   | Studies using thymocytes   | 44 |
| 2.4     | Discussion   | 64 |

### **CHAPTER 3**

#### **THE GENERATION OF STIMULATORY CULTURE SUPERNATANTS USING T CELL MITOGENS**

|       |   |    |
|-------|---|----|
| 3.1   | Introduction  | 71 |
| 3.2   | Materials and methods   | 74 |
| 3.2.1 | Animals and thymectomy operation                                | 74 |
| 3.2.2 | Tritiated thymidine incorporation following mitogen stimulation | 75 |
| 3.2.3 | Generation of SNs following PHA-M or Con A                      |    |

|   |    |
|---|----|
| stimulation   | 75 |
| 3.2.4 Removal of PHA using chicken red blood cells  | 76 |
| 3.2.5 Removal of Con A by treatment with<br>alpha-methyl-d-mannoside ( $\alpha$ mm)   | 77 |
| 3.2.6 Assay cells   | 77 |
| 3.2.7 Proliferation assay for SN activity   | 78 |
| 3.3 Results   | 78 |
| 3.3.1 Mitogen response of <i>X. borealis</i> and<br><i>X. tropicalis</i> splenocytes and thymocytes to PHA                          | 78 |
| 3.3.3 Studies on PHA-induced culture supernatants   | 79 |
| 3.3.3.1 Effect of CRBC treatment on PHA-M solutions   | 79 |
| 3.3.3.2 Promotion of mitosis by PHA-M-induced<br>supernatants: comparison of splenocytes and<br>splenic lymphoblasts as assay cells | 80 |
| 3.3.3.3 Promotion of mitosis by PHA-M-induced super-<br>natants: comparison of splenocytes and<br>thymocytes as assay cells         | 80 |
| 3.3.3.4 Attempt to generate ASN from thymocytes   | 81 |
| 3.3.4 Studies on Con A-stimulated mitogenesis   | 81 |
| 3.3.4.1 Mitogen response of control splenocytes to<br>Con A   | 81 |
| 3.3.4.2 Effect of thymectomy on Con A stimulation   | 81 |
| 3.3.5 Studies on Con A-induced culture supernatants   | 82 |
| 3.3.5.1 Effect of alpha-methyl-d-mannoside on<br>removal of Con A   | 82 |
| 3.3.5.2 Comparison of PHA-P and Con A-induced SNs to<br>stimulate splenocytes from thymectomised and<br>control <i>X. laevis</i>    | 82 |
| 3.4 Discussion  | 95 |

#### CHAPTER 4

#### DEVELOPMENT OF A MINIATURISED CULTURE SYSTEM TO ASSAY SUPERNATANT ACTIVITY: USE OF CONTROL AND THYMECTOMISED *XENOPUS*

|                           |     |
|---------------------------|-----|
| 4.1 Introduction          | 99  |
| 4.2 Materials and methods | 102 |

|         |  |     |
|---------|--|-----|
| 4.2.1   | Animals  | 102 |
| 4.2.2   | Miniaturised assay for supernatant activity using Terasaki plates  | 103 |
| 4.2.3   | Mitogen assay using conventional 96-well plates  | 104 |
| 4.2.4   | Generation of active supernatants using PHA-P  | 105 |
| 4.3     | Results  | 106 |
| 4.3.1   | Proliferative responses to PHA-P   | 106 |
| 4.3.1.1 | PHA-P dose response of LM3 splenocytes in "standard" technique: effect of serum supplementation  | 106 |
| 4.3.1.2 | PHA-P dose response of LM3 thymocytes in "standard": effect of serum supplementation   | 106 |
| 4.3.1.3 | Reactivity to PHA-P effected by splenocytes cultured in serum-free, AL-15:FCS(1%) or AL-15:BSA media in "standard" technique                 | 107 |
| 4.3.1.4 | Comparison of standard and miniaturised techniques to measure PHA-P stimulation and effect of CRBC adsorption                                | 108 |
| 4.3.2   | Use of "standard" and "miniaturised" assays to measure responses to PHA- and MLC- induced supernatants                                       | 109 |
| 4.3.2.1 | Comparison of PHA-P, PHA-P-SN and MLC-SN on proliferative responses: standard technique  | 109 |
| 4.3.2.2 | Effect of PHA-P, PHA-P-SNs and MLC-SNs on proliferative responses of precultured cells, assayed with the miniaturised technique              | 109 |
| 4.3.2.3 | Effect of PHA-P, MLC-SNs and PHA-P-SNs on proliferative responses of precultured splenocytes: comparison of standard and miniaturised assays | 110 |
| 4.3.2.4 | Effect of PHA-P, MLC-SNs and PHA-P-SNs on proliferative responses of precultured thymocytes: comparison of standard and miniaturised assays  | 111 |
| 4.3.3   | Studies on 7-day-thymectomised <i>Xenopus</i>  | 111 |
| 4.3.3.1 | Ability of MLC-SNs to induce proliferation of splenocytes from control and thymectomised <i>Xenopus</i>                                      | 111 |
| 4.3.3.2 | Effect of PHA-P, PHA-SNs and MLC-SNs on  |     |

|  |     |
|--|-----|
| proliferative responses of precultured splenocytes from control and thymectomised animals  | 112 |
| 4.3.3.3 Effect of PHA-P and PHA-P-SNs on proliferative responses of precultured splenocytes from control and thymectomised animals: use of Terasaki plates | 113 |
| 4.3.3.4 Effect of thymectomy on supernatant generation   | 113 |
| 4.4 Discussion   | 128 |

## **CHAPTER 5**

### **USE OF ANTI-IgM MONOCLONAL ANTIBODY TO EXPLORE THE NATURE OF SPLENCYTES RESPONSIVE TO CULTURE SUPERNATANTS**

|  |     |
|--|-----|
| 5.1 Introduction   | 132 |
| 5.2 Materials and methods  | 136 |
| 5.2.1 Animals and thymectomy operation   | 136 |
| 5.2.2 Culture of mouse hybridoma cells   | 137 |
| 5.2.3 Production of hybridoma culture supernatants   | 139 |
| 5.2.4 Fluorescent microscopic studies on leucocytes stained with the monoclonal antibodies XT-1, 8E4:57 and 8E4:13.3 | 139 |
| 5.2.5 Flow cytometric analysis of leucocytes stained with anti-IgM monoclonal antibodies                             | 141 |
| 5.2.6 Protocol for leucocyte sorting using the FACS and subsequent culture of sorted cells                           | 142 |
| 5.2.7 Miniaturised supernatant assay for FACS-sorted splenocytes   | 145 |
| 5.2.8 Protein "concentration" procedures   | 146 |
| 5.3 Results  | 149 |
| 5.3.3 Initial characterisation of anti-IgM and anti-T cell monoclonal antibodies by fluorescence microscopy          | 149 |
| 5.3.1.1 Studies on splenic lymphocytes prior to and following PHA stimulation  | 149 |
| 5.3.1.2 Studies of splenocytes and thymocytes stained with the McAbs 8E4:57, 8E4:13.3 or XT-1                        | 150 |
| 5.3.1.3 Comparison of splenocytes from control and   |     |

|       |  |     |
|-------|--|-----|
|       | thymectomised <i>Xenopus laevis</i> , stained with anti-IgM antibody (8E4:57)  | 150 |
| 5.3.2 | Flow cytometric analyses of leucocytes stained with anti-IgM antibodies: Comparison of splenocytes from control and thymectomised <i>X. laevis</i> | 151 |
| 5.3.3 | Effect of PHA-P, PHA-P-SNs and MLC-SNs on unsorted, sIgM <sup>+</sup> and sIgM <sup>-</sup> sorted splenocytes from thymectomised <i>Xenopus</i>   | 152 |
| 5.3.4 | Attempts to "concentrate" Con A-SNs  | 153 |
| 5.4   | Discussion   | 165 |

## CHAPTER 6

### ATTEMPTS TO CHARACTERISE AND ISOLATE SPLENIC DENDRITIC CELLS

|         |  |     |
|---------|--|-----|
| 6.1     | Introduction   | 170 |
| 6.2     | Materials and methods  | 175 |
| 6.2.1   | Animals  | 175 |
| 6.2.2   | Percoll density gradients  | 175 |
| 6.2.3   | Separation of spleen cells on Percoll  | 177 |
| 6.2.4   | Protocol for the enrichment of "non-adherent" splenocytes for use as stimulators in MLC  | 177 |
| 6.2.5   | Injection of human immunoglobulin G  | 178 |
| 6.2.6   | Identification of human IgG associated with spleen cells by fluorescence microscopy: studies on cell suspensions and cell smears | 178 |
| 6.2.7   | Identification of class II MHC positive cells by fluorescence microscopy   | 180 |
| 6.2.8   | PHA-M assay  | 181 |
| 6.2.9   | Mixed leucocyte culture assay  | 181 |
| 6.3     | Results  | 183 |
| 6.3.1   | Fluorescence microscopic studies on antigen-retaining splenocytes  | 183 |
| 6.3.1.1 | Antigen retention by splenocytes: enrichment by Percoll separation   | 183 |
| 6.3.1.2 | Morphology of human IgG <sup>+</sup> splenocytes: use of cytopsin preparations   | 184 |

|         |   |     |
|---------|---|-----|
| 6.3.1.3 | Staining with anti-Xenopus class II monoclonal antibody (AM20)                        | 184 |
| 6.3.2   | Response of Percoll separated and separated <i>Xenopus</i> splenocytes to PHA-M       | 185 |
| 6.3.3   | Ability of Percoll-separated and -unseparated splenocytes to stimulate in one-way MLC | 185 |
| 6.3.4   | Ability of plastic non-adherent splenocytes to stimulate in one-way MLC               | 186 |
| 6.4     | Discussion  | 196 |

## CHAPTER 7

|  |     |
|--|-----|
| MAJOR CONCLUSIONS AND SUGGESTIONS FOR FURTHER WORK | 198 |
| REFERENCES   | 202 |
| APPENDIX   | 234 |

## LIST OF TABLES

| TABLE  | Page |
|--|------|
| 2.1 Kinetics of splenocyte one-way MLC in AL-15:BSA  | 53   |
| 2.2 Inability of MLC-ASNs to costimulate one-way splenocyte MLC  | 54   |
| 2.3 Effect of 24 hour "preculture" of splenic lymphoblasts on responsivity to MLC-SNs                                  | 55   |
| 2.4 Comparison of ability of "tube" or "plate" generated splenic blasts to respond to one-way MLC-SNs                  | 56   |
| 2.5 Ability of one-way MLC-SNs to stimulate blast cell populations of various genotypes                                | 57   |
| 2.6 Production of inhibitory SNs by control cultures in the absence or presence of irradiated syngeneic cells          | 58   |
| 2.7 Comparison of SNs generated in fresh medium or in 5 day conditioned medium   | 59   |
| 2.8 Effect of prior skin grafting on splenocyte MLC-SN production  | 60   |
| 2.9A Ability of thymocytes to respond in MLC   | 61   |
| 2.9B Effect of SN from two-way thymocyte and splenocyte MLC on splenocyte proliferation                                | 62   |
| 2.10 Thymocyte costimulation assays  | 63   |
| 3.1 Ability of PHA-M SNs to stimulate (8 day precultured) splenic lymphoblasts and splenocytes                         | 91   |
| 3.2 Ability of PHA-M-induced SNs to stimulate "fresh" thymocytes and splenocytes                                       | 92   |
| 3.3 Effect of alpha-methyl-d-mannoside on Con A responsiveness of J splenocytes  | 93   |
| 3.4 Effect of ("mitogen-free") PHA-P-SNs and Con A-SNs on splenocytes from control and Tx <i>X.laevis</i>              | 94   |
| 4.1 Effect of PHA-P on proliferative responses of splenocytes cultured in serum-free, AL-15:FCS(1%) or AL-15:BSA media | 125  |
| 4.2 Comparison of proliferative responses to PHA-P of splenocytes cultured in 96-well or Terasaki plates               | 126  |



|     |   |     |
|-----|---|-----|
| 4.3 | Effect of MLC-SNs on proliferative responses of splenocytes from LG5 control and thymectomised <i>Xenopus</i>   | 127 |
| 5.1 | Fluorescent antibody staining of LM3 splenocytes stained with McAbs 8E4:57 and XT-1   | 160 |
| 5.2 | Fluorescent antibody staining of splenocytes and thymocytes from <i>X.laevis</i> with anti-IgM McAbs and XT-1   | 161 |
| 5.3 | Fluorescent antibody labelling of splenocytes from control and Tx <i>X.laevis</i> with anti-IgM   | 162 |
| 5.4 | FACS analysis of fluorescent antibody labelling from control and thymectomised <i>X.laevis</i> stained with anti-IgM McAbs  | 163 |
| 5.5 | Effect of PHA-P, PHA-P-SNs and MLC-SNs on thymidine incorporation in unsorted, IgM <sup>+</sup> and IgM <sup>-</sup> splenocytes from thymectomised <i>X.laevis</i> | 164 |
| 6.1 | Percentage of human IgG <sup>+</sup> splenocytes: effect of Percoll separation  | 192 |
| 6.2 | Ability of PHA-M to stimulate Percoll separated and unseparated <i>X.laevis</i> splenocytes   | 193 |
| 6.3 | Ability of Percoll -separated and -unseparated splenocytes to act as stimulators in one-way MLC   | 194 |
| 6.4 | Ability of plastic non-adherent splenocytes to act as stimulators in one-way MLC  | 195 |

## LIST OF FIGURES

| <u>FIGURE</u>  | <u>Page</u> |
|--|-------------|
| 2.1 Kinetics of MLC in AL-15:BSA medium  | 46          |
| 2.2 Effect of MLC-SN dilution on proliferative responses of splenic lymphoblasts   | 47          |
| 2.3 Kinetics of SN production in one-way MLC   | 48          |
| 2.4 Effect of one-way MLC-SNs on "fresh", 5 day medium precultured LG15 spleen cells   | 49          |
| 2.5 Growth of <i>X. borealis</i> splenocytes fed MLC-ASNs or MLC-CSNs  | 50          |
| 2.6 Proliferative responses of LG5 "fresh" or PHA treated thymocytes to different doses of splenocyte MLC-SNs: cultured in AL-15:FCS | 51          |
| 2.7 Proliferative responses of LG5 "fresh" or PHA treated thymocytes to different doses of splenocyte MLC-SNs: cultured in AL-15:BSA | 51          |
| 2.8 4 day pretreatment of assay thymocytes in medium fails to make them responsive to MLC-ASNs                                       | 52          |
| 3.1 Response of <i>X. borealis</i> splenocytes to PHA-M  | 83          |
| 3.2 Proliferative responses of <i>X. borealis</i> thymocytes to PHA-M  | 84          |
| 3.3 Response of <i>X. tropicalis</i> thymocytes to PHA-M: comparison of medium supplemented with FCS or BSA                          | 85-         |
| 3.4 Responses of <i>X. tropicalis</i> splenocytes to PHA-P: comparison of medium supplemented with FCS or BSA                        | 86          |
| 3.5 CRBC-adsorption removes mitogenic properties from PHA-M  | 87          |
| 3.6 Effect of thymocyte PHA-P-SNs on LG15/wild splenocytes   | 88          |
| 3.7 Mitogen responses of splenocytes to Con A  | 89          |
| 3.8 Stimulation indices of splenocytes from control and 7-day thymectomised <i>X. laevis</i>   | 90          |
| 4.1 Miniaturised cell culture technique  | 115         |
| 4.2 Proliferative responses of LM3 splenocytes to  |             |

|   |     |
|---|-----|
| PHA-P when cultured in BSA- or FCS-supplemented media   | 116 |
| 4.3 Proliferative responses of LM3 thymocytes to PHA-P when cultured in BSA- or FCS-supplemented media  | 117 |
| 4.4 Comparison of PHA-P, PHA-P-SNs and MLC-SNs on proliferative responses of 8 day precultured LM3 splenocytes  | 118 |
| 4.5 Effect of PHA-P, PHA-P-SNs and MLC-SNs on proliferative responses of precultured splenocytes: Terasaki plates   | 119 |
| 4.6 Effect of PHA-P, MLC-SNs and PHA-P-SNs on proliferative responses of 6 day precultured LM3 spleen cells in Terasaki and 96-well plates                                  | 120 |
| 4.7 Effect of MLC-SNs and PHA-P-SNs on proliferative responses of 4 day and 6 day precultured LM3 thymocytes in Terasaki and 96-well plates                                 | 121 |
| 4.8 Effect of PHA-P, PHA-P-SNs and MLC-SNs on proliferative responses of 4 day precultured splenocytes from LM3 control and thymectomised <i>Xenopus</i> in Terasaki plates | 122 |
| 4.9 Effect of PHA-P and PHA-P-SNs on proliferative responses of 4 day precultured splenocytes from LG5 control and thymectomised <i>Xenopus</i> in Terasaki plates          | 123 |
| 4.10 Effect of PHA-P-SNs generated from control and thymectomised LG15 splenocytes  | 124 |
| 5.1 Hybridoma cells   | 155 |
| 5.2 FACS profiles of splenocytes from control and thymectomised <i>Xenopus laevis</i> labelled with anti-IgM antibody   | 156 |
| 5.3 Dot plots of control and thymectomised <i>Xenopus laevis</i> siblings   | 157 |
| 5.4 FACS profiles of FACS sorted splenocyte populations from thymectomised <i>Xenopus laevis</i>  | 158 |
| 5.5 Contour plots of FACS sorted splenocyte populations from thymectomised <i>Xenopus laevis</i>  | 159 |
| 6.1 Separation of leucocytes over Percoll gradients   | 187 |
| 6.2 <i>Xenopus</i> "XL-like" cells in splenocyte preparations   | 188 |

- 6.3 Fluorescence staining pattern on "XL-like" cells from *Xenopus* injected with human IgG and labelled with FITC-labelled anti-human IgG 189
- 6.4 Cytospin preparations of splenocytes from *Xenopus* injected with human IgG then labelled with FITC-anti-human IgG 190
- 6.5 Fluorescence staining pattern on *Xenopus* splenocytes labelled with mouse anti-class II antibody plus FITC-labelled anti-mouse Ig antibody 191

## ABBREVIATIONS

|                |  |
|----------------|--|
| Ab             | antibody                               |
| Ag             | antigen                                |
| AL-15          | amphibian strength Leibovitz-15 medium |
| APC            | antigen-presenting cell                |
| APBS           | amphibian phosphate buffered saline    |
| ASN            | active supernatant                     |
| BSA            | bovine serum albumin                   |
| Con A          | concanavalin A                         |
| CRBC           | chicken red blood cells                |
| CSN            | control supernatant                    |
| DLS            | dorsal lymph sac                       |
| ELISA          | enzyme-linked immunosorbent assay      |
| FACS           | fluorescent activated cell sorter      |
| FCS            | foetal calf serum                      |
| FlAb           | fluorescent antibody                   |
| FITC           | fluorescein isothiocyanate             |
| Ig             | immunoglobulin                         |
| IL-            | interleukin                            |
| McAb           | monoclonal antibody                    |
| MHC            | major histocompatibility complex       |
| MLC            | mixed leucocyte culture                |
| NK cell        | natural killer cell                    |
| PBS            | phosphate buffered saline              |
| PHA            | phytohaemagglutinin                    |
| SAS            | solid ammonium sulphate                |
| SN             | supernatant                            |
| TCGF           | T cell growth factor                   |
| T <sub>c</sub> | cytotoxic T cell                       |

Th            helper T cell  
Ts            suppressor T cell  
Tx            thymectomised  
TNBS        trinitrobenzenesulphonic acid

## CHAPTER 1

### GENERAL INTRODUCTION

#### 1.1 Immunology of *Xenopus*

Comparative immunology is concerned with the study of the immune system in a variety of animals at strategic evolutionary levels. Immunological studies of representative species of the various vertebrate classes (mammals, birds, reptiles, amphibians and fish) and also of a panorama of invertebrate organisms have begun to reveal how the immune system evolved (e.g. see Horton & Lackie, 1989).

Within the class Amphibia is the order Anura, which encompasses frogs and toads. The most widely studied anuran animal model with respect to its immune system is the South African clawed toad/frog (genus *Xenopus*) (Du Pasquier, Schwager & Flajnik, 1989). The *Xenopus* immune system possesses many similar features to the mammalian immune system. *Xenopus* has been chosen as a representative of this order for a number of reasons, including the ease with which *Xenopus* can be bred and maintained under laboratory conditions. Furthermore, studies of the *Xenopus* immune system have been helped considerably by the availability of inbred *Xenopus* strains (Katagiri, 1978) and MHC (major histocompatibility complex) identical clones (Kobel and Du Pasquier, 1975), production and increasing

availability of monoclonal antibodies (McAbs) to a variety of *Xenopus* cell surface molecules (reviewed by Du Pasquier, Schwager and Flajnik, 1989; Flajnik, Hsu, Kaufman & Du Pasquier, 1988). There are a number of useful cellular markers for *Xenopus*. For example, cells from the species *Xenopus borealis* can be labelled using a quinacrine stain which labels the DNA present in the cells (Thiébaud, 1983). The use of triploid and diploid *Xenopus*, together with ploidy labelling techniques have also been used to trace cell movements within transplanted tissue (Turpen et al, 1982; Turpen & Smith, 1986).

A major histocompatibility complex has been identified in *Xenopus*. This complex is the region of the genome which codes for MHC proteins, that play a crucial role in immunological recognition by T-lineage lymphocytes. The *Xenopus* MHC (known as the XLA) codes for the molecules which are crucially involved in stimulating a mixed leucocyte response (MLR, Du Pasquier & Miggiano, 1973) and in the generation of cytotoxic T cells (Tc). In *Xenopus*, as in mammals, the latter cells undoubtedly play a crucial rôle in the rejection of foreign skin grafts and destruction of virally-infected cells (Bernard et al, 1979; Cohen, personal communication). MHC antigens also play a critical rôle in the collaboration of *Xenopus* T helper (Th) cells with B cells, to bring about antibody production (Blomberg, Bernard & Du Pasquier, 1980; Bernard et al, 1981). Class I, II and III subregions have been identified within the *Xenopus* XLA (Flajnik et al,



1984; Kaufman *et al*, 1985; Nakamura *et al*, 1986).

In mammals, antigen can be presented in the context of different classes of MHC molecules, either class I or class II MHC proteins. The T lymphocyte subsets ( $T_h$  and  $T_c$ ), which recognise antigen (or antigenic peptide) only when it is presented in association with a particular class of MHC molecule, are said to be "restricted" to that particular class. Thus, the subset of T cells known as  $T_h$  cells tend to be restricted to class II molecules, whilst the  $T_c$  cells are generally class I restricted. However, there is a minority of mammalian  $T_c$  cells that are class II restricted (Braakman *et al*, 1987). In *Xenopus* the response to alloantigen in the mixed leucocyte response (equivalent to the phase in graft rejection when  $T_h$  cells are active) is mediated through recognition by T cells (Du Pasquier & Horton, 1976) of class II antigens (Flajnik, Du Pasquier & Cohen, 1985). The existence of *Xenopus*  $T_c$  cells that are effective against class II MHC antigens has also been recently demonstrated (Horton, Horton & Varley, 1989). However, the extent to which  $T_c$  cells are restricted to class I or II MHC antigens has yet to be thoroughly investigated in *Xenopus*.

As is the case with mammals, *Xenopus* have been shown to possess both T and B lymphocytes. *Xenopus* T cells differentiate in the thymus, an organ consisting of a medulla rich in epithelial cells and a lymphocyte-rich cortex.

A mouse monoclonal antibody (XT-1) specific for

*Xenopus* T-lineage cells was raised by Nagata (1985). This antibody recognises a 120kD membrane protein, called XTLA-1, on the majority but not all, of *Xenopus* peripheral T cells (Nagata, 1985, 1986a, 1986b). Studies using this McAb have revealed that XTLA-1 positive lymphocytes appear in the thymus at stage 48 (7 days old) and the level of XTLA-1 positive cells increases sharply until stage 49 (10 days old; Nagata, 1986a). Thus, stage 48-49 is thought to represent the first stages of phenotypic thymocyte differentiation in *Xenopus* (Katagiri & Tochinai, 1987).

Anuran T cells are nylon wool non-adherent and proliferate when cultured with the classical mammalian T cell mitogens phytohaemagglutinin (PHA) and concanavalin A (Con A). The importance of the rôle of T cells in the *Xenopus* immune system can be demonstrated by the removal of the thymus (and hence the source of T cells) in early larval life. Thymectomy within the first week of life (i.e. until stage 48 of Nieuwkoop and Faber, 1967) severely impairs skin allograft rejection and leucocyte responses in mixed leucocyte culture (MLC; Horton & Manning, 1972; Tochinai & Katagiri, 1975; Kaye & Tompkins, 1983; Nagata & Cohen, 1983; Du Pasquier & Horton, 1976). Such early thymus ablation also impairs or abrogates proliferative responses to the classical T cell mitogens PHA and Con A (Du Pasquier & Horton, 1976; Manning, Donnelly & Cohen, 1976; Donnelly, Manning & Cohen, 1976) and antibody responses against T dependent antigens, such as rabbit red blood cells (Tochinai &

Katagiri, 1975; Du Pasquier & Wabl, 1977). Responses to T-independent mitogens (i.e. B cell mitogens) e.g. lipopolysaccharide (LPS) and protein derivative of tuberculin (PPD) are left intact following thymectomy (Manning, Donnelly & Cohen, 1976), and B cell rich zones of, for example, the spleen remains fully lymphoid (Bleicher & Cohen, 1981).

A study involving the sequential thymectomy of *Xenopus laevis* toads revealed that thymectomy at stages 54-55 of development (28-31 days old, Nieuwkoop & Faber, 1967) abrogated leucocyte responsiveness to PHA. However, thymectomy at stage 51 (15-16 days) or earlier was required to prevent leucocyte proliferation in MLC (Horton & Sherif, 1977). A gradual establishment of different T cell subsets in the periphery during ontogeny is therefore suggested.

*Xenopus* B cells differentiate in the early larval liver (Hadji-Azimi, Schwager & Thiébaud, 1982). In contrast to higher vertebrates, the *Xenopus* bone marrow does not appear to play a part in the development of B cells since there is an absence of pre-B cells in the bone marrow of both adult and larval *Xenopus*. In addition, B cells and plasma cells are rarely found in adult *Xenopus* bone marrow (Hadji-Azimi, Coosemans & Canicatti, 1990). *Xenopus* B cells are characterised by being radiation sensitive, nylon wool adherent and surface immunoglobulin positive (sIg<sup>+</sup>). Such B cells respond relatively poorly to the mammalian B cell mitogen, *E. coli* lipopolysaccharide (LPS). It is

generally believed that the low proliferation achieved by this mitogen is due to a contaminant present in commercial LPS preparations (Bleicher *et al*, 1983). The latter, nevertheless, induce Ig synthesis in *Xenopus* B cells (Williams *et al*, 1983). Hsu & Leanderson also noted that induction of Ig synthesis in *Xenopus* B cells could be achieved using doses of LPS that were mitogenic for mammalian cells (Du Pasquier, Schwager & Flajnik, 1989). *Xenopus* B cells are stimulated to proliferate and differentiate *in vitro* by pokeweed mitogen (PWM) and by anti-IgM antibodies (Schwager & Hadji-Azimi, 1984; Schwager & Hadji-Azimi, 1985).

*Xenopus* B cells can produce three classes of immunoglobulin; IgM, which is analogous to IgM in mammals, IgY, which is equivalent to the mammalian IgG, and IgX, which is associated, in particular, with gut plasma cells and could therefore be an IgA-equivalent class. However, the *Xenopus* antibody repertoire is much more restricted in size than that of mammals (Du Pasquier, Schwager & Flajnik, 1989). The spleen is rich in IgM positive B cells, whereas this organ contains very few IgY and IgX cells (Du Pasquier, Schwager & Flajnik, 1989).

*Xenopus* is a useful model with which to study immunological development, since its free-swimming larva is unaffected by maternal influences. Furthermore, *Xenopus* can also be relatively easily manipulated as embryos or larvae. These features have been exploited in a number of ways. For example, thymectomy (removal of the

thymus) can be achieved very soon after the thymus bud appears at 3 days post-fertilisation (see Katagiri & Tochinai, 1987), when there is very little differentiation of the thymus. This surgical operation may be considered to have certain advantages when compared with the "thymusless" nude mouse model, since the thymectomised *Xenopus* represents a genetically normal animal, developing without the influence of the thymus.

There are a number of strategies for exploring the rôle of the *Xenopus* thymus in immune development and, in particular, on T cell education i.e. on the rôle the thymus plays in conferring "MHC restriction" and "self-tolerance" in developing T-lineage cells. One of these strategies is to use thymus-reconstituted, thymectomised (Tx) toads. Thus, Tx *Xenopus* can be reimplanted with a histoincompatible thymus in late larval life. Such thymuses are seeded by host-derived "stem" cells, as shown by the use of the quinacrine marker (Horton *et al*, 1987). This thymus transplantation induces tolerance to the donor strain as assessed by *in vivo* skin grafting (Horton & Horton, 1975; Arnall & Horton, 1986). However, coculture of splenocytes from the thymus-reconstituted Tx *Xenopus* with stimulator cells from the donor strain results in a positive *in vitro* MLC reaction (Arnall & Horton, 1986). In addition, 5000R irradiated splenocytes from the donor strain produced splenocyte proliferation when injected *in vivo* into allothymus reconstituted Tx animals (Arnall & Horton, 1987). These animals are said to display "split tolerance" - tolerance to skin, but not

with respect to MLC responsiveness.

Another way of examining thymic education and the phenomenon of "split tolerance" is by using certain *Xenopus* chimeras. These chimeras are produced by joining the anterior portion of one embryo with the posterior portion of a genetically different embryo, when both embryos are only 24 hours old. Thus, when the toad develops, the thymic epithelium derives from the anterior portion, whilst the haemopoietic stem cells (which can give rise to lymphocytes) arise from the posterior part of the embryo (Flajnik, Du Pasquier & Cohen, 1985). These chimeras will accept skin grafts of the same genotype as the anterior part of the embryo, but leucocytes from these animals will proliferate *in vitro* to stimulator leucocytes of the anterior genotype.

It is also possible to induce tolerance in *Xenopus* to incompatible genotypes by grafting disparate donor skin onto perimetamorphic or larval *Xenopus* (Di Marzo & Cohen, 1982; Arnall & Horton, 1987). The success of inducing tolerance by this method is dependent on genetic disparity of donor or host, graft size and the age of the host. The successful tolerising protocol uses large grafts (2-5mm<sup>2</sup>) differing by only one MHC haplotype (Di Marzo & Cohen, 1982; Arnall & Horton, 1987).

The identification and role of lymphokines in the *Xenopus* immune system has only recently begun to be investigated. For example, there is now evidence that factors resembling (functionally) mammalian IL-1 (Watkins, Parsons & Cohen, 1987) and others resembling T

cell growth factors (TCGF) are produced by *Xenopus*. Evidence for TCGF in *Xenopus* will be dealt with in detail below, but first it is necessary to provide a review of the rôle that TCGF plays in the mammalian immune system and comment on evolutionary aspects of this important lymphokine.

## 1.2 Lymphokines and interleukin-2

### 1.2.1 Mammalian studies

"Lymphokine" is the term used to describe the soluble mediators released by lymphocytes, this term is distinct from terms such as "monokine" and "cytokine" which refer, respectively, to the mediators released by cells of the monocyte lineage and non-lymphoid cells (as defined by Hamblin, 1988). [It should be noted that other authors use the term "cytokine" as an umbrella term to cover the soluble mediators released by cells of any type.]

"Lymphokines" are proteins or glycoproteins, produced by lymphocytes, that are involved in homeostatic control of the immune system. Several hundred activities ascribed to lymphokines have been described. Of the lymphokines studied, many have been shown to have pleiotropic effects and often to act synergistically with other lymphokines (reviewed by Hamblin, 1988; Gearing,

1989).

Interleukin ("between leucocytes") -2 (IL-2), previously called T cell growth factor (TCGF), is one of the most studied, and consequently best characterised lymphokines. Mammalian (Human) IL-2 has a molecular weight of 15kD and is composed of 153 amino acids. The production and functions of IL-2 have been elucidated largely through the existence of T cell lines and the application of molecular cloning techniques.

The human IL-2 gene has been cloned (Taniguchi *et al*, 1983) and sequenced (Fujita *et al*, 1983; Holbrook *et al*, 1984). In order to understand the structure-function relationship of the molecule, its tertiary structure has also been studied (Cohen *et al*, 1986; Brandhuber *et al*, 1987; Landgraf *et al*, 1989).

Unstimulated T cells (in the resting G<sub>0</sub> phase of the cell cycle) do not express high affinity receptors for IL-2 on their cell surface and thus respond poorly, if at all, to IL-2. High affinity IL-2 receptors (IL-2R) are induced on T cells when the T cell receptor complex (the complex which recognises antigenic peptide when it is co-presented with MHC molecules) is stimulated through antigen recognition (Cantrell & Smith, 1983; Gullberg & Smith, 1986). IL-2R expression is accompanied by a phenomenon known as "blastogenesis". The T cell enters the G<sub>1</sub> phase of the cell cycle and increases in size to become a "blast" cell (Herzberg & Smith, 1987). T cell blasts respond to IL-2 by proliferation.

Stimulation of T cells by antigen, MLC or mitogen



has a two-fold effect. As well as inducing IL-2R expression on T cells it also causes the stimulated T cell to produce IL-2, which can act in both an autocrine and paracrine fashion. The proliferation of T cell blasts (or T cell lines) in response to exogenous IL-2 has become a standard assay in detecting the presence of IL-2 in mammalian culture supernatants (SNs).

The IL-2R consists of two polypeptide chains, the p75 alpha chain and the p55 beta chain. The alpha chain is found at low concentrations on resting T cells. On activation, upregulation of alpha chains and beta chains ensues. Each polypeptide chain possesses an individual binding site for IL-2 (Tsuda *et al*, 1986; Teshigawara *et al*, 1987). The p75 alpha and p55 beta chain have been shown to have, respectively, intermediate and low binding affinities for IL-2. Examination of the IL-2 binding kinetics using McAbs directed against IL-2 and the p55 beta chain of the IL-2R (the anti-TAC McAb) revealed that only when both the alpha and beta chains came together were authentic high affinity IL-2 receptors made (Wang *et al*, 1987; Smith, 1988a & b).

It has been shown by using the anti-TAC McAb that beta chains are expressed on cell types other than T cells. For example, p55 beta chains have been demonstrated on natural killer (NK) cells (Tsuda *et al*, 1987; Siegel *et al*, 1987) and on activated B cells (Nakanishi *et al*, 1984; Muraguchi *et al*, 1985). IL-2R expression and B cell responses to IL-2 are discussed more fully in subsequent chapters.

### 1.2.2 Comparative studies

IL-2 has been purified from mitogen-stimulated leucocyte culture supernatants (SNs) from human (Mier & Gallo, 1982; Gillis & Watson, 1980), mouse (Riendeau *et al*, 1983; Granelli-Piperno *et al*, 1981), rat (Di Sabato, 1982) and gibbon (Henderson *et al*, 1983) sources.

The technique of purifying proteins from culture SN has been superseded by molecular cloning techniques. This has resulted in the availability of human (Taniguchi *et al*, 1983), mouse (Kashima *et al*, 1985) and bovine (Reeves *et al*, 1986; Cerretti *et al*, 1986) recombinant IL-2 (rIL-2). Monoclonal antibodies towards the IL-2R of these species have also been generated and thus kinetic binding studies have been undertaken (Uchiyama, 1981; Seiss *et al*, 1989).

In mammalian cross reactive studies IL-2 from human, primate and rat can induce the proliferation of mouse lymphoblasts. However, human lymphoblasts do not proliferate in response to rat, mouse or gibbon IL-2.

A brief review of IL-2 -like factors in invertebrates and non-mammalian vertebrates follows.

#### Echinoderms

The starfish *Asterias rubens* possesses an ancestral lymphoid organ known as the axial organ. Luquet and Leclerc (pers. comm.) showed that "T-like" cells from

this axial organ, when cultured in MLC, produced a soluble factor(s). This proteinaceous factor caused proliferation of the complete cell population of the axial organ, when added to these cells *in vitro*. Although this is far from convincing evidence for an IL-2-like molecule, it does demonstrate that soluble mediators, or lymphokines, are probably present in animals from the phylum Echinodermata. This is of interest in comparative studies since this phylum is at the origin of the branch leading to vertebrates.

### Fish

An IL-2-like factor has been described for carp (*Cyprinus carpio*; Grondel & Harmsen, 1984; Caspi & Avtalion, 1984). These authors generated factors through *in vitro* mitogen and alloantigen (MLC) stimulation of leucocytes from outbred animals. The mitogen-derived SNs were found to possess more stimulatory (proliferative) activity for carp blasts (pronephric leucocytes that had been cultured with PHA) than the MLC-derived active supernatants (ASNs). This is due to the polyclonal nature of the mitogen response, which will cause proliferation of the majority of T cells, compared with the stimulation of only a subset of T cells in an alloantigen response. Grondel and Harmsen also noted that mitogen-stimulated cultures had produced good levels of factor(s) by 24 hours. In comparison, SNs from the MLCs required longer culture periods (48 hours - 6 days) to produce maximum

factor levels.

In the above experiments MLC control supernatants (CSNs), i.e. SNs from cocultures of syngeneic cells, were not investigated. Instead these authors' control experiment was to culture the assay lymphoblasts in medium alone; they then used this background level of tritiated thymidine incorporation as a control value. This may have had important implications on the analysis of the data as the effect of 'factors' spontaneously released by leucocytes upon *in vitro* culture were not taken into account. Thus, their control was not a "true" control.

Interestingly, these same authors showed that human, rat and gibbon IL-2-rich SNs stimulated carp blasts to proliferate, whilst mouse IL-2-rich SN had no proliferative effect on carp blasts.

Mammalian (human) IL-1, in the presence of suboptimal doses of the T cell mitogen, Con A, stimulates peripheral blood lymphocytes of the channel catfish, suggesting the early phylogenetic emergence of the recognition of IL-1 (Hamby et al, 1986).

### Reptiles

Splenocytes from the snake *Spalerosophis diadema* that were Con A activated, produced a culture SN that supported the proliferation of snake splenic lymphoblasts (El Ridi, Wahby & Saad, 1986). A polypeptide of 14-15kD was believed to be responsible for this activity.

## Birds

Schauenstein, Globerson and Wick (1982) and Schnetzler *et al* (1983) demonstrated the existence of an IL-2-like factor from mitogen (PHA and Con A) -stimulated cultures of chicken lymphocytes. Antigen primed chicken peripheral blood leucocytes (PBL) were able to be kept in continuous proliferation *in vitro* for more than 25 weeks by culturing PBLs with SNs from mitogen-treated chicken leucocytes (Vaino, Ratcliffe & Leanderson, 1986). These authors ascribed the activity to a protein with a molecular weight of approximately 13kD (for review see Schauenstein & Krömer, 1987). The generation of monoclonal antibody towards the putative chicken IL-2R (Schauenstein *et al*, 1988) revealed that the kinetics of receptor [called chicken-activated-T-lymphocyte-antigen (CATLA)] expression during T cell activation were analogous to the kinetics of mammalian IL-2R expression.

SNs from Con A treated mouse leucocytes will not cause chicken blasts to proliferate, and Con A-derived SNs from chicken leucocytes will not drive the proliferation of mouse lymphoblasts (Schauenstein, Globerson & Wick, 1982).

## Amphibians

Leucocytes from 12 month old outbred *Xenopus laevis* were cocultured in bi-directional MLC and an activity was

demonstrated in the SNs at 24 hours after initiation of culture (Gearing, 1985). The assay used to detect activity was a thymocyte costimulation assay. In this assay a suboptimal dose of PHA is used in order to induce IL-2 receptors on the lymphocytes with minimal proliferation of the thymocytes themselves. The presence of IL-2 will cause further proliferation of the thymocytes, which can be measured by tritiated thymidine incorporation. Since either IL-2 or IL-1 can cause thymocyte proliferation in mammalian systems, this is not a specific assay for IL-2. IL-1 potentiates the proliferative response of T cells to mitogens and antigens, and thus can cause a proliferative response in the thymocyte costimulation assay. In addition, the validity of the thymocyte costimulation assay, with respect to the detection of IL-2 and IL-1, has also come into question (Gearing, 1989), since it appears that other lymphokines can substitute for IL-1 function in this assay (Dinarello, 1987; Le & Vilcek, 1987)

A more detailed study of *X.laevis* TCGF was carried out by Watkins and Cohen (1987). SNs were generated by coculture of leucocytes from adult, outbred, MHC undefined *X.laevis* with T cell mitogen (principally PHA). The PHA was subsequently removed by incubation (adsorption) with chicken red blood cells (CRBC). It was demonstrated that a 24 hour PHA- or Con A-derived SN (with the mitogen removed) could cause the growth (as assayed by cell number) and proliferation (as assayed by tritiated thymidine incorporation) of *Xenopus* splenic and

thymic lymphoblasts, i.e. leucocytes that had been precultured with PHA to bring about blastogenesis (and, theoretically, IL-2R expression). These SNs also costimulated *Xenopus* thymocytes in a PHA costimulation assay. The activity of the ASNs was ascribed to a protein of molecular weight 15kD by SDS-PAGE (polyacrylamide gel electrophoresis). However, activity was not eluted from this band. Cross reactivity studies have shown that human rIL-2 and mouse IL-2-rich SNs do not drive proliferation of *Xenopus* lymphoblasts *in vitro*. Likewise *Xenopus* IL-2-rich SN does not promote proliferation of a mouse T cell line (Watkins, 1985; Watkins & Cohen, 1987).

However, there is evidence to suggest that mammalian IL-2 may modulate *Xenopus* immune responses *in vivo*. For example, the response to trinitrophenol-ficoll (TNP-ficoll) is thymus dependent in *Xenopus*. Indeed, *X.laevis* thymectomised even in early adult life, are unable to respond to TNP-ficoll (unless treated with reagents that cause stimulation of T cell activity in the periphery). Murine IL-2 (affinity purified), human IL-2 (affinity purified) and mammalian rIL-2 - each - separately administered with TNP-ficoll were all able to substitute for the presence of a thymus in adult Tx *X.laevis* (Ruben, Clothier & Balls, 1985).

Another example of rIL-2 activity *in vivo* in *Xenopus* comes from hapten-carrier experiments. In order for *X.laevis* to respond to haptens, e.g. trinitrophenol (TNP), the hapten has to be presented with a thymus dependent (TD) immunogenic carrier, e.g. sheep red blood

cells (SRBC). In addition, before the hapten-carrier is administered the toad must be primed *in vivo* with the carrier alone. Human rIL-2 administered *in vivo* can substitute for the need to prime the *Xenopus* with the carrier (SRBC), but the priming must be undertaken less than 3 hours before the hapten-carrier (TNP-SRBC) is administered (Ruben, 1986). A third example of rIL-2 activity *in vivo* is that it can modulate the phenomenon of TNP-induced tolerance. Injection of TNBS into *Xenopus* conjugates TNP to the animals' cells and proteins. In *Xenopus* this induces tolerance if TNP is subsequently presented on ficoll. *In vivo* injection of human rIL-2 breaks this state of tolerance (Ruben *et al*, 1987)

The process by which mammalian rIL-2 modulates such *in vivo* responses in *Xenopus* is unclear. However, McAbs to the p55 beta chain of the mammalian IL-2R (anti-TAC) have been used to demonstrate the presence of the TAC antigen on *Xenopus* leucocytes (Langeberg *et al*, 1986/7; Ruben *et al*, 1989a & b). Stimulation of the splenocytes using mitogen, followed by anti-TAC labelling experiments revealed an increase in the number of TAC<sup>+</sup> cells, and in the amount of TAC expressed per cell (Langeberg *et al*, 1986/7; Ruben *et al*, 1989b). Thus, mitogen stimulation appears to increase the number of IL-2 receptor expressing leucocytes, as is the case in mammals. However, there is currently dispute over whether the human rIL-2 or anti-TAC McAb bind to the genuine *Xenopus* IL-2R and not some other irrelevant epitope (Cohen, N, unpublished paper presented at the joint BSDB and BSI



conference in Durham, 1987).

Mammalian rIL-2 administered to mice has been shown to break the induction of tolerance induced to semi-allogeneic cells during neonatal life (Malkovsky & Medawar, 1984). IL-2 has also been shown to break the maintenance of tolerance when skin allografts were subsequently applied (Asherson *et al*, 1985; Loveland, Hunt & Malkovsky, 1986). However, human rIL-2 failed to break skin allo-tolerance in *Xenopus* that had received perimetamorphic skin grafts and had borne the grafts for at least 100 days without any sign of rejection (Horton *et al*, 1989). Thus, human rIL-2 failed to modulate the maintenance of tolerance. In contrast, some preliminary evidence suggests that this recombinant lymphokine may influence the induction of allotolerance when injected at the time of transplantation to perimetamorphic larvae (Ruben *et al*, 1989).

### 1.3 Purpose of thesis

The major aim of this Thesis has been to investigate the nature of "lymphokines" produced by *Xenopus* T cells *in vitro*. It was considered that the availability of such *Xenopus*-derived lymphokines would greatly benefit ongoing studies in this laboratory, which are exploring the immunoregulation of transplantation tolerance and the possible differentiation of "T-equivalent" cells through thymic-independent pathways.

The work began (Chapter 2) by exploring "lymphokine" production achieved in MLC responses. Supernatant generation by this method had the advantage of having no mitogen present in the ASNs. Furthermore, alloantigen-induced lymphokine production had not been studied in any depth by Watkins and Cohen (1987).

The finding (Chapter 2) that MLC-ASNs induced proliferation of "unstimulated" assay cells, was of particular interest since this contrasted with Watkins and Cohen's work (that revealed only blast cells could respond to T cell derived growth factors generated by PHA-stimulation). It therefore seemed essential to study the nature of mitogen-induced ASNs in our own laboratory, to directly compare findings from the two laboratories with T cell mitogen generated ASNs. The experiments with PHA and Con A (and the SNs derived from them) are presented in Chapter 3. A miniaturised technique for assaying mitogen and MLC ASNs is described in Chapter 4, this miniaturisation being necessary to minimise the amount of "lymphokine" used and to allow experiments on few assay lymphocytes (i.e. cells from Tx animals) to take place. Chapters 3 and 4 indicate a T-dependency of "lymphokine" production, but that T-independent cells can respond well to these factors. In Chapter 5, the nature of the T-independent responding leucocytes is explored by the use of an anti-IgM monoclonal antibody (McAb) and through fluorescence-activated cell sorting.

Other aspects of the MLC response in *Xenopus* - i.e. the nature of the stimulating cells - were investigated

at the beginning of these Ph.D studies, but since the experiments were somewhat inconclusive and do not tie in closely with the major theme of the thesis, they are included in Chapter 6.

Conclusions and suggestions for further work are given in chapter 7.

MIXED LEUCOCYTE CULTURE IN XENOPUS AND THE PRODUCTION OF  
GROWTH FACTORS THROUGH ALLOANTIGEN STIMULATION.

2.1 INTRODUCTION

Mammalian interleukin 2 (IL-2) is a polypeptide "cytokine" released by activated T helper cells, that triggers growth of a variety of cell types e.g. T and B cells and natural killer (NK) cells (reviewed in Smith, 1988; Hamblin, 1988). Interleukin 2 receptor (IL-2R) is the protein that binds IL-2, and is comprised of two polypeptides, the alpha and beta chains. Resting T (and B) cells have small numbers (approx. 500) of alpha chains (mol. wt. 75kD) and essentially no beta chains (mol. wt. 55kD). After lymphocyte activation, the beta chains are actively produced, the alpha chains less so, resulting in approximately 5000 alpha chains and up to 50,000 beta chains on each activated T cell. The high affinity receptors for IL-2 are alpha-beta heterodimers, that can respond to low concentrations of IL-2. Such high affinity receptors are found only on activated T cells (Cantrell & Smith, 1983; see review by Roitt, Brostoff & Male, 1989). Thus the presence of (low concentrations of) IL-2 can be detected by its ability to cause the growth and proliferation of activated T cell blasts. [The low affinity receptors are the beta chains, which by themselves, are not able to interact with IL-2 and activate cells. The alpha chain alone is an IL-2 receptor of intermediate affinity and

can be involved in activation in the presence of high concentrations of IL-2. Thus resting cells - e.g. NK cells - possessing high concentrations of alpha chains, can also be stimulated by this cytokine].

T cell mitogens or alloantigens can be used to stimulate leucocyte cultures to obtain culture supernatants (SNs) which secrete an array of cytokines (Hagiwara *et al*, 1987; Cherwinski *et al*, 1987), including IL-2. Previous work on *Xenopus* lymphokines has primarily focussed on the use of mitogens, such as phytohaemagglutinin (PHA) or concanavalin A (con A), as the principle method for generating factors that can subsequently be shown to achieve growth of "activated" T cells - called T cell growth factors (TCGF) by Watkins & Cohen, 1987. Such mitogens are polyclonal activators, which stimulate many T cells, regardless of their antigen specificity. In this way more TCGF is likely to be generated than by stimulating a much smaller subset of T cells, e.g. by coculture with alloantigen. However, there is the disadvantage of having to remove all the mitogen from the culture SNs before assaying for induced growth factors. This is particularly pertinent, since there may be a costimulatory effect between any lymphokine present in the SN and residual mitogen.

The most extensive study of *Xenopus* TCGF (Watkins & Cohen, 1987) used mainly PHA-derived SNs. These authors removed PHA activity by treatment with chicken red blood cells (CRBC, see Grimm & Rosenberg, 1982). This protocol appeared to be an effective method (as determined by bioassay) of PHA removal. However, Watkins and Cohen admit

that residual PHA may have been present in some SNs, but claim that this would have little bearing on the outcome of their experiments. Watkins and Cohen partially purified the PHA-SNs. This appeared to remove any residual PHA. Further analysis of the PHA-SNs by SDS-PAGE revealed a protein band with a molecular weight of 15 - 20kD. However, the IL-2-like activity in this band was not eluted. Thus the IL-2-like activity cannot be categorically ascribed to this 15 - 20kD protein.

In this Chapter, experiments are described which utilise mixed leucocyte culture (MLC) to generate putative lymphokines. As noted above, this protocol eliminates the problem of possible mitogen involvement in the assays. There has been some investigation of *Xenopus* factors in SNs generated from 24 hour splenic MLCs (Gearing, 1985; Watkins, 1985; Watkins & Cohen, 1987). Gearing showed that a MLC-induced SN (MLC-SN) could cause proliferation of thymocytes, when tested in a costimulation assay, with suboptimal doses of T cell mitogen. In mammals, this assay detects the presence of both IL-1 and IL-2. Thus, Gearing's results are rather ambiguous, with respect to determining whether IL-2- or IL-1-like factors were being produced in MLC-induced SNs.

Watkins (1985) showed that culture SNs from a *Xenopus* alloreactive T cell line, re-stimulated in MLC, could achieve the growth and proliferation of mitogen-induced T cell blasts, a standard assay for IL-2 in mammals. These studies involved the use of splenocytes taken from LG15 *Xenopus*, that had been grafted with J skin and subsequently restimulated *in vitro* with J cells in MLC, in the presence of crude (CRBC-

passed) TCGF (obtained from mitogen-treated cultures).

Watkins (1985) demonstrated that fresh *Xenopus* splenocytes were unable to proliferate when cocultured with PHA-SNs or MLC-SNs. This was attributed to the lack of IL-2 receptor expression on the surface of resting splenocytes. However, experiments using the human anti-beta chain monoclonal antibody (anti-TAC McAb) revealed that a proportion of freshly biopsied *Xenopus* splenocytes could bind the anti-TAC antibody (Langeberg *et al*, 1987; Ruben *et al*, 1989a & b). This suggests that a small number of *Xenopus* splenocytes may constitutively express IL-2R. Treatment of *Xenopus* splenocytes with PHA raised the number of human IL-2R-positive splenocytes considerably.

The level of induced proliferation in MLC in *Xenopus* is an index of class II incompatibility between leucocytes from different individuals (Du Pasquier, Chardonnens & Miggianno, 1975). A T cell subset is thought to mediate this MLC response, the evidence for this coming from a number of studies. Removal of the thymus in early larval life has a profound effect on subsequent T cell development and function. Du Pasquier and Horton (1976) demonstrated that splenic leucocytes from 7-day thymectomised (tx) *Xenopus laevis* were unable to mount a MLC response to allogeneic stimulators. Other studies of early thymectomised animals supported this view (Horton & Sherif, 1977; Nagata & Cohen, 1983), Horton and Sherif showing later thymectomy had no effect on MLC reactivity, whereas PHA responses were still intact.

Further evidence for T cell involvement in the *Xenopus* MLC came from studies of the removal of surface immunoglobulin (sIg)-bearing cells (B cells) from the leucocyte population. Depletion of B cells by nylon wool adherence (Blomberg, Bernard & Du Pasquier, 1980), and through "panning" on an anti-IgM McAb (Bleicher & Cohen, 1981), produced an enhanced MLC response from the remaining T cell rich population of cells, when compared with that of the total population.

Nagata (1986a & b) used the XT-1 McAb, produced in his laboratory (1985), which is directed towards a marker (XTLA-1) on thymocytes and which labels many, but not all, peripheral T cell populations. He showed that the XTLA-1 positive population gave a strong MLC response, but that a MLC response could also be demonstrated in the XTLA-1 negative population of splenocytes, though of a much smaller magnitude.

In this Chapter, the basic experimental plan was to establish the kinetics of MLC-induced production of "TCGF" and determine the effective dose for use in our assay system. The choice of assay cells themselves has come under scrutiny here. Leucocytes to be used to assay "TCGF" were taken from spleen and thymus, and then were either PHA-stimulated, to produce blasts, that would be expected to have induced receptors for putative TCGF, or left "unstimulated". Experiments to modulate the size and strength of the MLC response, and hence to effect the amount of active SN production, are also explored; these experiments involved



grafting of animals with allogeneic skin prior to restimulation in MLC.

It was also necessary to investigate the consequences of gamma-irradiation on SN production, since the majority of MLCs established were one-way cultures, where the stimulator cells are irradiated. In mammals,  $\gamma$ -irradiation up to 3000 rads, does not preclude the secretion of IL-2 (see review by Grimm & Rosenberg, 1982). However, high dose irradiation (6000-10 000 rads) of mammalian splenocytes abrogated the production of IL-2 by these splenocytes. The high dose-irradiated splenocytes were able to stimulate non-irradiated T cells to produce IL-2 (Heeg, Steeg & Wagner, 1988).

## 2.2 MATERIALS AND METHODS

### 2.2.1 Animals

Outbred *Xenopus laevis* were purchased from Xenopus Ltd. Other *Xenopus* were reared in the laboratory. J strain (formally called G strain) animals were from toads originally donated by C. Katagiri of Hokkaido University, Japan. These *Xenopus laevis* are MHC homozygous (jj haplotype), but possess minor histocompatibility differences. LG15 (MHC=ac), LG17 (MHC=ac) and LM3 (MHC=wy) clones of animals were originally generated (Kobel & Du Pasquier, 1979) by crossing *Xenopus laevis* with *Xenopus gilli* (for LG clones) or with *Xenopus muelleri* (for LM clones). These interspecies crosses produced females that ovulate both small, haploid, eggs and large,

diploid, eggs. The diploid eggs are formed through a process of endoreplication during oögenesis. The large eggs (secondary oöcytes) can be fertilised with ultra-violet (UV)-irradiated sperm, to give clonal offspring, that are identical to the mother and each other (Kobel & Du Pasquier, 1979).

### 2.2.2 Animal breeding and maintenance

Animals were induced to spawn by injections of human chorionic gonadotrophin (HCG; Griffin and George) via the dorsal lymph sac (DLS). Naturally fertilised embryos were collected on nylon netting and transferred to tanks of aerated dechlorinated water.

To produce LG and LM clones, HCG primed females (50-100 international units (I.U.) injected 24 hours prior to required ovulation and 500 I.U. 5 hours beforehand) were gently squeezed, around the lower abdomen, until they expelled their eggs. The eggs were fertilised by a UV-irradiated (6 mins at 254nm) sperm suspension. The next day, eggs were handsorted into large and small eggs. Both sets of embryos were raised in aerated dechlorinated water. - If the UV-irradiation of the sperm had been successful the haploid (small egg) animals would die several days after fertilisation, which invariably occurred.

Tadpoles were maintained in aerated dechlorinated tap water at  $23 \pm 1^{\circ}\text{C}$  and fed nettle powder as previously described (Horton & Manning, 1972). After metamorphosis, toadlets were fed *Tubifex* worms, before being introduced to

minced heart. Adults were maintained at 20 - 23°C and fed twice weekly on minced beef heart.

### 2.2.3 Preparation of leucocyte suspensions:

#### Removal of the spleen and thymus

Organ removal was carried out in a laminar air flow hood, the working surface of which was swabbed down with 70% alcohol. All instruments were treated with 95% alcohol. Animals were given an overdose of anaesthetic [3-aminobenzoic acid ethyl ester (Sigma)]. 70% alcohol was then liberally applied to the ventral skin, prior to spleen removal and/or to the head area, for thymus removal.

#### Spleen

Using scissors and watchmakers forceps, the skin and body wall on the left hand side of the abdomen were removed. The stomach was then pulled out of the body cavity, revealing the spleen below. The spleen was excised and placed in a small, sterile petri-dish (Costar) containing approximately 1ml sterile culture medium.

#### Thymus

Using scissors and watchmakers forceps, the region of skin between the eye and the forearm was removed. The pigmented thymus was excised, and the surrounding fatty tissue cut away. The cleaned pair of thymi were then placed in a small sterile petri-dish (Costar) containing approximately 1ml sterile culture medium.

### Cell preparation

The spleen or thymus was gently crushed between the frosted ends of two sterile glass slides. The cells were then transferred in 1-2mls of medium to a 5ml plastic test tube (Falcon), and left on ice for one minute to allow clumps to settle. The cell suspension was then carefully removed (the clumps being discarded) and washed twice in cold, sterile medium. Cells were spun at 300g for 10 minutes at 4°C for this washing procedure. Washed cells were counted in a Neubauer, American Optical haemocytometer. Only viable leucocytes were counted; these were distinguished by their ability to exclude trypan blue.

#### 2.2.4 Media

The basic medium used was Leibovitz-15 (L-15) medium (Flow Labs), diluted to amphibian osmolarity (200-220mosm) by the addition of double distilled water. This medium was further modified by addition of 0.01M HEPES buffer, 1.25mM glutamine, 50IU/ml penicillin, 50 $\mu$ g/ml streptomycin, 2.5 $\mu$ g/ml fungizone (all from Flow Labs) and 0.083mM 2-mercaptoethanol (BDH). This amphibian strength medium was supplemented either with heat-decomplemented fetal calf serum (FCS; Gibco) or bovine serum albumin (BSA, Fraction V, Sigma). The FCS was usually added to give a final concentration of 1% or 10% and such amphibian L15 medium is referred to as AL-15:FCS (1%) or AL-15:FCS(10%). BSA was added at a final concentration of 0.25% w/v and this medium is referred to as AL-15:BSA. All

media were filter-sterilised using 0.22 $\mu$ m filters (Flowpore). Just prior to setting up cultures, 0.01M sodium bicarbonate (Flow Labs) was added as an additional buffer and for nutritional purposes.

#### 2.2.5 Skin grafting

The donor and host animal were anaesthetised in 3-aminobenzoic acid ethyl ester (Sigma). The host was prepared for receiving a skin graft by the removal of a 2mm<sup>2</sup> dorsal piece of skin. A slightly bigger square of donor belly skin was then transplanted onto the prepared area, the edges being "tucked under" the host skin. The procedure was carried out under a dissecting microscope. The host was then kept in a small tank with Ringer's solution (see Appendix 1) filled to a depth of only 1-2cm (to avoid dislodging the dorsally-situated graft). After 8-10 hours, the host was returned to a tank filled with water.

#### 2.2.6 MLC assays

##### a) 'Normal' assays

AL-15:BSA medium was used throughout. Spleen or thymus suspensions were prepared from animals aged 10-12 months, as described previously. Stimulator cells were given a dose of 6000R from a <sup>60</sup>Co source. Cells were resuspended at a concentration of 1 x 10<sup>6</sup> leucocytes/ml for the responders, and 0.5 x 10<sup>6</sup> leucocytes/ml for the stimulators. For experimental cultures, 100 $\mu$ l aliquots of each suspension was

dispensed into individual wells of 96-well V-based plates (Sterilin; CellCult). Control cultures consisted of responders versus irradiated "responders" (adjusted to  $0.5 \times 10^6$  leucocytes/ml). Cells were cultured at  $26 \pm 1^\circ\text{C}$  in 5%  $\text{CO}_2$  for up to 120 hours. 24 hours before harvesting, each well was pulsed with  $1\mu\text{Ci}$  tritiated thymidine (Amersham; Sp.Act.  $5\text{Ci}/\text{mmol}$ ).

Cells were harvested onto fibre-glass filter mats (Skatron) using a semi-automatic harvester (Skatron). The filters were dried in an oven at  $60^\circ\text{C}$  for one hour and individual filters were then punched out into scintillation vials (Packard; pico hang-in vials). 4mls of scintillation fluid (National Diagnostics; betafluor) were added to each vial. Vials were placed in racks and analysed for tritiated thymidine levels in a scintillation counter (Packard; Tricarb). Mean disintegrations per minute (dpm) of tritiated thymidine and the standard error of the mean (sem) are presented in the data.

Stimulation indices [SIs] were calculated for MLCs using the following formula:

$$\text{SI} = \frac{\text{experimental culture (mean dpm)}}{\text{control culture (mean dpm)}}$$

Where there were surplus leucocytes available, other cultures were set up (comprising  $200\mu\text{l}$  irradiated stimulator or 'responder' cells only) and the following formula used:

$$\text{SI} = \frac{\text{expt. cult. (dpm)} - \text{irrad. stim./2 (dpm)}}{\text{cont. cult. (dpm)} - \text{irrad. resp./2 (dpm)}}$$

Counts from irradiated populations were generally <500 dpm.

b) Experiments to investigate possible MLC  
costimulation by MLC-SNs

AL-15 was used throughout. Suspensions were made of responder (LM3) and stimulator (LG15) splenocytes. The stimulator leucocytes were given a dose of 6000R from a  $^{60}\text{Co}$  source. Both leucocyte suspensions were adjusted to a concentration of  $1 \times 10^6$  leucocytes/ml. 100 $\mu\text{l}$  aliquots of responder leucocytes were dispensed into 96-well V-based plates. 50 $\mu\text{l}$  of either irradiated stimulator (allogeneic) or irradiated responder (syngeneic) leucocytes were added to the LM3 responders. In addition 50 $\mu\text{l}$  medium or MLC-SNs (ASN or CSN) were added to bring the final volume to 200 $\mu\text{l}$ . All cultures were set up in triplicate and incubated at  $26 \pm 1^\circ\text{C}$  in 5%  $\text{CO}_2$ .

After 48hrs culture each well was pulsed with 1 $\mu\text{Ci}$  tritiated thymidine and harvested 24hrs later for scintillation counting.

2.2.7 MLC-induced production of mitotic factors:  
proliferation assays

Supernatant generation

Splenocytes from 1-2 year old *Xenopus* were established in one-way MLC using AL-15:BSA, after the method of Watkins and Cohen (1985). Supplementation with BSA, rather than FCS, meant there would be less contaminating proteins, should any protein purification protocols be attempted at a later stage. Responders ( $4-5 \times 10^6$  leucocytes) were cocultured at  $26 \pm 1^\circ\text{C}$  in 5%  $\text{CO}_2$  with half the number of 6000R irradiated allogeneic or syngeneic stimulators in 2ml volumes, in 24-well flat-based tissue culture plates (Sterilin; Cell Cult). At the required time point, putatively active SNs (ASNs) from allogeneically-stimulated cells, and control SNs (CSNs) from cells cultured with syngeneic stimulators, were harvested. Harvesting was effected by centrifuging the cells at 300g for 10mins at  $4^\circ\text{C}$  and removing the SN. The SNs were filtered through  $0.2\mu\text{m}$  filters (Flowpore) and stored frozen ( $-18^\circ\text{C}$ ) in cryovials (Nunc) until used.

For the generation of SNs from two-way MLC, the procedure was the same, except there was no irradiation of the leucocytes.

In some experiments thymocytes, from animals 5-8 months old, were used to generate SNs. The SN generation procedure was the same as detailed above.



### Blast cell generation

Splenocytes from 9-12 month old *Xenopus* ( $4-5 \times 10^6$  leucocytes) were stimulated with an optimal dose (1/500) of PHA-M (Flow Labs) in 1ml AL-15:FCS(10%). Cells were (generally) cultured in 24-well flat-based tissue culture plates (Sterilin; Cell Cult) - but see 2.3.3.3. Cultures were maintained at  $26 \pm 1^\circ\text{C}$  in 5%  $\text{CO}_2$ . After 5 days, leucocytes enriched for lymphoblasts were harvested by density gradient centrifugation, using Histopaque (Sigma) of density 1.077g/ml. Leucocytes in suspension were gently layered onto the Histopaque and spun at 250g for 5 mins at  $4^\circ\text{C}$ . Using a pasteur pipette, leucocytes at the interface (of medium and Histopaque) were collected and washed before assay. In some experiments cell separation over Histopaque was not performed.

Thymic blasts, from animals 4-8 months of age, were generated in the same way.

"Control" leucocytes were cultured without PHA-M and then collected and assayed in the same way as blast cells.

### Proliferation assay for SN activity

The assay cells used in the following experiments were either splenocytes or thymocytes, precultured with or without PHA-M, as detailed above.

The assay cells were adjusted to  $1 \times 10^6$  leucocytes/ml in AL-15:FCS(1%). 100 $\mu\text{l}$  aliquots were then dispensed into individual wells of a 96-well flat-based tissue culture plate (Sterilin; Cell Cult). 50 $\mu\text{l}$  ASN (experimental cultures), CSN

(control cultures) or AL-15:BSA medium was added. Volumes were adjusted to 200 $\mu$ l (with AL-15:FCS(1%)) to give a final "in well" concentration of 25% SN. Leucocytes were incubated at 26  $\pm$  1°C in 5% CO<sub>2</sub>. Cultures, set up in triplicate, were pulsed at 48 hours with 1 $\mu$ Ci tritiated thymidine (Amersham; Sp.Act. 5Ci/mmol). Cultures were harvested 24hr later for scintillation counting, as detailed earlier.

Stimulation indices (SIs) were calculated using the following formula:

$$SI = \frac{\text{experimental cultures (i.e. +ASN) (mean dpm)}}{\text{control cultures (i.e. +CSN) (mean dpm)}}$$

SIs were not calculated using the dpm from assay leucocytes cultured in medium alone, since such dpm were often quite different from assay cells cultured with CSN.

#### 2.2.8 Cell growth assay

Splenocytes from a 1 year old *Xenopus borealis* were cultured in AL-15:FCS(5%). Splenocytes were cultured at 4 - 5 x 10<sup>6</sup> leucocytes/ml with 0.2 $\mu$ g/ml PHA-P (Flow Labs) or medium alone for 5 days in 24-well flat-based plates. Cells were then washed and adjusted to 2 x 10<sup>6</sup> leucocytes/ml in 24-well plates. PHA-P and non PHA-P treated leucocytes were then fed every 4 days with MLC-ASNs or CSNs at a final concentration of 20%. At intervals spleen cell counts were calculated using a haemocytometer. Viable cells were distinguished by their ability to exclude trypan blue.

### 2.2.9 Thymocyte costimulation assay

Thymocytes from 3 month post-metamorphic animals were used. Thymocytes were adjusted to a concentration of  $1 \times 10^6$  leucocytes/ml in AL-15:FCS(1%). 100 $\mu$ l aliquots were then dispensed into individual wells of a 96-well flat-based tissue culture plate (Sterilin; Cell Cult). Thymocytes were given a suboptimal dose (see Chapter 3) of PHA-P (0.02 $\mu$ g/ml) in 50 $\mu$ l of AL-15:FCS(1%). 50 $\mu$ l of the test SN was then added. Controls consisted of cells cultured in medium alone, PHA-P alone or SN alone. In all cases the final concentration of SN (and AL-15:BSA) was 25%.

Cultures, set up in triplicate, were pulsed at 48 hours with 1 $\mu$ Ci tritiated thymidine (Amersham; Sp.Act. 5Ci/mmol). Cultures were harvested 24hr later for scintillation counting, as detailed earlier.

### 2.2.10 Statistics

The mean and standard error of the mean (sem) were calculated for each set of experimental data (usually triplicates).

The student's t-test was used to compare any pair of data. P values of 0.05 and below were considered to be significant.

## 2.3 RESULTS

### 2.3.1 Kinetics of splenocyte one-way MLC in AL-15:BSA

These experiments assessed whether splenocytes could be successfully cultured in AL-15:BSA medium to generate a mixed lymphocyte response (MLR). Previous experiments on MLC in *Xenopus* have tended to use FCS-supplemented media (Du Pasquier *et al*, 1975; Du Pasquier *et al*, 1976; Arnall & Horton, 1986). Stimulation indices above 2 were achieved on days 3, 4 and 5 of culture (see Table 2.1 and Fig 2.1). Proliferation, as measured by tritiated thymidine uptake of both the experimental and control cultures, increased with increasing culture times.

### 2.3.2 Inability of MLC-ASNs to costimulate one-way splenocyte MLCs

Responder splenocytes did not respond any better in MLC when cocultured with MLC generated ASNs (see example of one of several experiments in Table 2.2). Indeed, both ASNs and CSNs significantly ( $p < 0.01$  (expt. 1);  $p < 0.001$  (expt. 2)) lowered the tritiated thymidine counts produced by the allogeneic cultures, when compared with splenocytes set up in MLC in medium alone. ASNs did, however, achieve a significant ( $p < 0.01$ ) <sup>increase</sup> in thymidine uptake in the syngeneic cultures (LM3 x RLM3) when compared with other syngeneic cultures given CSNs. Thymidine uptake in the latter cultures was also significantly ( $p < 0.001$ ) reduced when compared with syngeneic

cultures established in medium alone.

### 2.3.3 Proliferative responses of splenic lymphoblasts to MLC-SNs

#### 2.3.3.1 Effect of dilution of MLC-SNs

In several replicate experiments, PHA-induced splenoblasts showed optimal proliferation to MLC-induced ASNs at dilutions of 1/4 and 1/8. This was true for ASNs from both one-way (data not shown) and two-way MLCs (see Fig 2.2, which shows an example of a typical experiment). CSNs at this dilution often resulted in splenic lymphoblasts showing thymidine counts lower than when the same blasts were cultured with medium alone.

#### 2.3.3.2 Kinetics of SN production in one-way MLC

In this experiment, "ASNs" harvested within 24 hours after establishing the MLC did not enhance proliferative activity when assayed on 5 day old splenic lymphoblasts (see Fig 2.3). The maximum SI was achieved by using ASNs from 48hr MLCs. High activity of ASNs was still present in SNs harvested from 120hr MLCs.

One-way MLC from CSNs (from syngeneic cultures) routinely lowered thymidine incorporation levels to below the level of those achieved by blast cells cultured in medium alone. However, this inhibitory effect was markedly less with CSNs harvested at 120hrs. The inhibitory effect was probed in further experiments (see 2.3.6 below).

### 2.3.3.3 Experiments investigating the nature of assay blast cells

These experiments were performed in order to find the best conditions for generating assay cells sensitive to the SNs.

#### a)Effect of one-way MLC-SNs on lymphoblasts assayed directly or following additional "preculture" in assay wells.

This experiment was performed in order to ascertain if 5-day old lymphoblasts 'deprived' of potential growth factors (in the MLC-SNs) for 24 hours before SN addition, proliferated any better to the SNs than the same 5-day old lymphocyte population given MLC-SNs without this 24 hour delay.

24 hours of additional preculture of 5-day old blast cells in the 96-well assay plates did not improve their ability to respond to MLC-SNs (compared with blasts assayed immediately after 5 days of preculture with PHA). Tritiated thymidine counts achieved by MLC-SNs were lowered when the "precultured" blasts were used (see Table 2.3).

#### b)Effect of generation of blasts in tubes or in plates on their ability to one-way MLC-SNs.

Blasts generated in tubes for 3 or 5 days produced very high background levels of tritiated thymidine incorporation following further culture for 3 or 4 days in the assay plates (see Table 2.4). 5 day old "tube-generated" blasts (i.e. those harvested 8 or 9 days after establishing in culture) gave the highest counts observed. Blasts

generated for 5 days in 24-well plates produced much lower levels of counts, at the end of the 3 or 4 day assay period in medium alone. Moreover, such blasts generated in 24-well plates yielded higher stimulation indices than "tube-generated" blasts following the 3 or 4 day assay period with MLC-ASNs (Table 2.4).

Since "plate-generated" blasts gave better SIs with the MLC-SNs, blasts were generated using 24-well plates in all subsequent experiments.

c) Ability of one-way MLC-SNs to stimulate blast cell populations of various genotypes.

MLC-ASNs generated by coculture of J splenocytes with irradiated LM3 splenocytes for 1, 2, or 5 days, were effective on blast cells of the responder (J) type and stimulator (LM3) type. The same SNs also showed stimulatory activity on spleen lymphoblasts from a third party (LG15) animal (see Table 2.5).

2.3.4 Ability of one-way MLC-SNs to stimulate proliferation of both PHA-precultured and non PHA-treated spleen cells.

These experiments (see Fig 2.4) reveal that MLC-ASNs are able to promote proliferation not only of 5 day old PHA-generated blasts, but also of splenocytes precultured for 5 days in FCS medium alone, and those cells taken for assay directly from the animal.

### 2.3.5 Growth of splenocytes and blasts fed MLC-SNs

Both 5 day medium precultured splenocytes and 5 day PHA-precultured splenoblasts increased in number 2 days after being fed MLC-ASN or MLC-CSN (Fig 2.5), although cells given MLC-ASN did not grow (in number) significantly more or less than cells given MLC-CSN. Cell numbers gradually declined, despite repeated feeding of the cells every 4 days with SNs. (Culture medium was also changed every 4 days).

### 2.3.6 Experiments to probe the inhibitory nature of CSNs

#### a) Production of inhibitory MLC-CSNs is not due to the presence of irradiated cells

CSNs varied in their inhibitory effect on the proliferation of assay cells. There was no correlation between the presence of irradiated cells and the production of inhibitory CSNs, since splenocytes established in culture without irradiated syngeneic cells also produced CSNs that reduced proliferation of assay cells to below that of background levels (assay cells cultured in medium alone; see Table 2.6). It should also be noted that some CSNs are mildly stimulatory compared to background levels (see Chapter 3).

#### b) Comparison of SNs generated in fresh or in conditioned medium

Medium was conditioned by 5 day preculture with LG15 splenocytes (at  $2 \times 10^6$  leucocytes/ml). Conditioning the medium produced a 24hr MLC-CSN that was no less inhibitory



than when CSNs were generated from the same splenocyte population cultured instead for 24 hours in fresh medium. However in this experiment, use of conditioned medium generated a 24hr SN from the allogeneic culture that achieved good stimulation of assay cells, in contrast to the MLC-ASN generated in fresh medium, which failed to stimulate the assay cells (see Table 2.7).

### 2.3.7 Effect of prior skin grafting on splenocyte MLC-SN production.

Splenocytes from J strain animals that had previously been given an LM3 skin allograft and then restimulated with LM3 cells *in vitro*, routinely generated MLC-ASNs with a higher level of proliferative activity, than their autografted counterparts (see Table 2.8). This was true for SNs harvested at both 24 and 96 hours, which suggests enhanced factor production (following *in vivo* priming) continues for several days after initiation of MLC.

The finding that preimmunisation *in vivo* - generated a more active MLC-ASN, but had no effect on MLC-CSN activity, indicates that such ASN production involves an alloimmune response *in vitro*, potentiated by prior *in vivo* stimulation of responder cells with allogeneic skin.

### 2.3.8 Studies using thymocytes

#### a) Thymocytes respond in MLC but fail to produce MLC-ASN.

Thymocytes were cultured in two-way MLC in AL-15:BSA medium with some success (Table 2.9A). Proliferation of allogeneically-stimulated <sup>thymocytes</sup>  $\Delta$  was small but significantly increased over autologous cultures.

SNs from two-way thymocyte and splenocyte MLC cultures were assayed for their proliferative potential in Terasaki plates (see Chapter 4). SNs from the thymocyte MLC possessed no proliferative activity as measured by the tritiated thymidine assay, using splenocytes (2.9B). However the MLC-SNs generated from splenocytes harvested from the same animals produced ASN with good proliferative activity for the assay splenocytes.

#### b) Splenocyte-derived MLC-SNs and PHA fail to costimulate thymocytes.

There was little or no thymocyte costimulation observed when a sub-optimal dose of PHA-P was administered along with a splenocyte MLC-ASN (see Table 2.10). PHA-P alone caused mild stimulation of the thymocytes, whereas ASN by itself was ineffective at promoting significant thymocyte proliferation.

#### c) Proliferative response of PHA-treated thymocytes to splenocyte MLC-ASNs.

In both FCS- (Fig 2.6) and BSA- (Fig 2.7) supplemented

media the profiles of the dose response was similar. With non-precultured - "fresh" - thymocytes (taken directly from the animal), there was little difference between the effects of splenocyte MLC-ASN and MLC-CSN. Thymocyte proliferation increased as both SNs became more dilute. Unfortunately medium control dpm levels were not obtained.

In contrast, after PHA-M treatment of thymocytes for 4 days, the curves for subsequent coculture with MLC-ASN and MLC-CSN were quite different. The splenocyte MLC-ASN showed considerable stimulatory activity of PHA-treated thymocytes, especially at dilutions of 1/4, 1/8 and 1/16. The CSNs, on the other hand, failed to raise thymidine incorporation of such PHA-treated thymocytes above the medium controls.

An additional experiment compared thymocyte responses following 4 days culture either in PHA or in FCS medium alone. This was to discern if this preculture in medium was by itself inducing responsiveness of the thymocytes to MLC-ASN.

Fig 2.8 reveals that thymocytes had to be treated with PHA to become responsive to the MLC-ASN.

FIG. 2.1

LM3 responder splenocytes ( $1 \times 10^5$  leucocytes/well) were cultured with 6000R irradiated LG15 stimulator splenocytes ( $0.5 \times 10^5$  leucocytes/well) in 96-well V-based tissue culture plates in AL-15:BSA. Cultures were set up in triplicate. Each well was pulsed with  $1\mu\text{Ci}$  [ $^3\text{H}$ ]TdR 24 hours before harvesting. Cells were harvested at day 1, 2, 4 & 5.

The data here is from one representative experiment (see table 2.1).

FIG. 2.1 KINETICS OF MLC IN AL-15:BSA MEDIUM

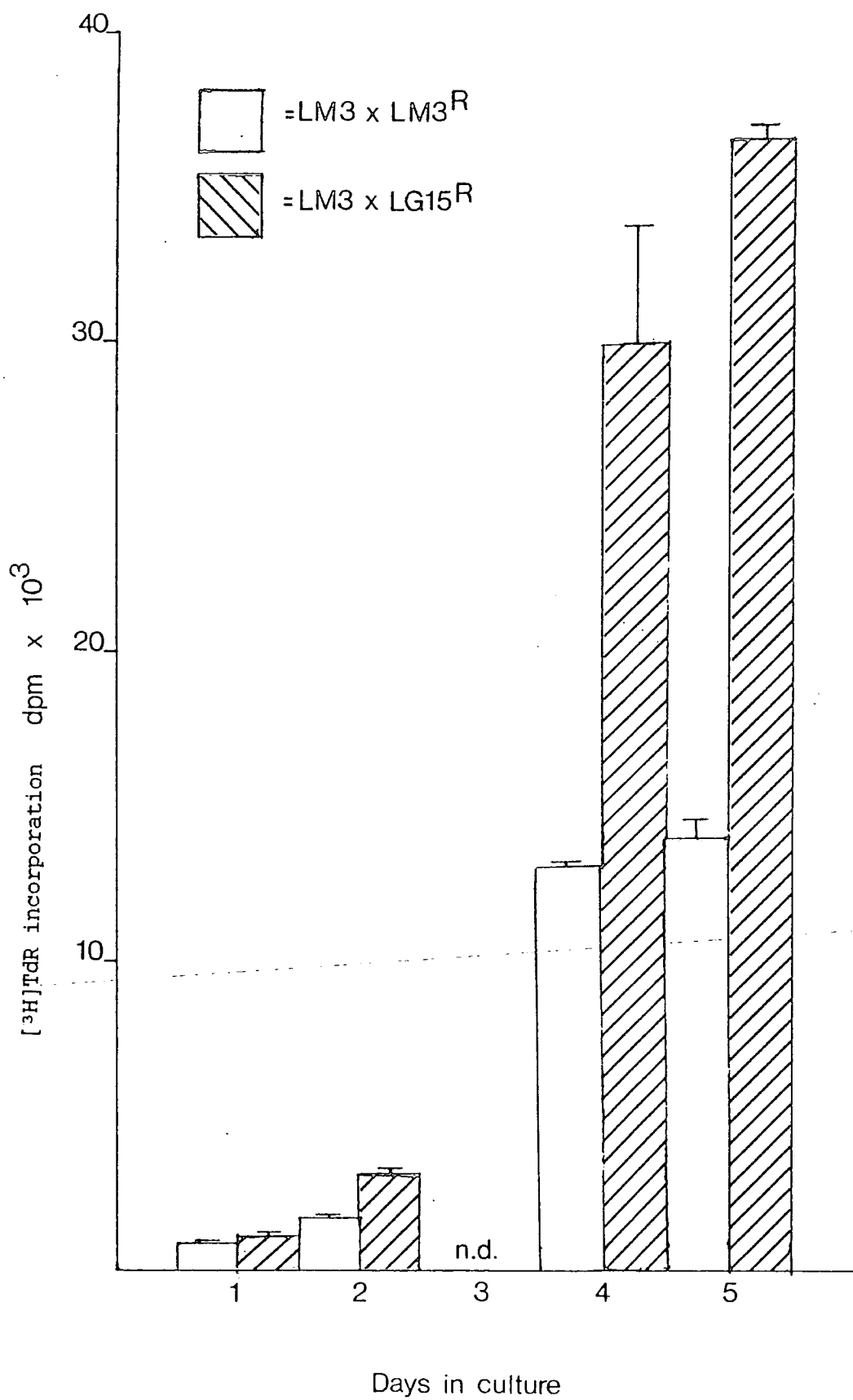

FIG. 2.2

XbJ splenocytes were stimulated with PHA-M and cultured in 24-well flat-based tissue culture plates ( $4-5 \times 10^6$  leucocytes/ml) for 5 days in AL-15:FCS(10%). Cells were then ficoll-passed.

A range of (24 hour-generated) MLC-SN dilutions was made in AL-15:BSA in volumes of  $100\mu\text{l}$  in 96-well flat-based tissue culture plates. Assay cells (XbJ) were dispensed ( $1 \times 10^5$  leucocytes/well) in  $100\mu\text{l}$  aliquots in AL-15:FCS(1%).

After 48 hours of culture, each well was pulsed with  $1\mu\text{Ci}$  [ $^3\text{H}$ ]TdR and harvested 24 hours later.

The dotted line represents the dpm of the XbJ cells cultured in medium alone.

FIG. 2.2 EFFECT OF MLC-SN DILUTION ON PROLIFERATIVE RESPONSES OF SPLEENIC

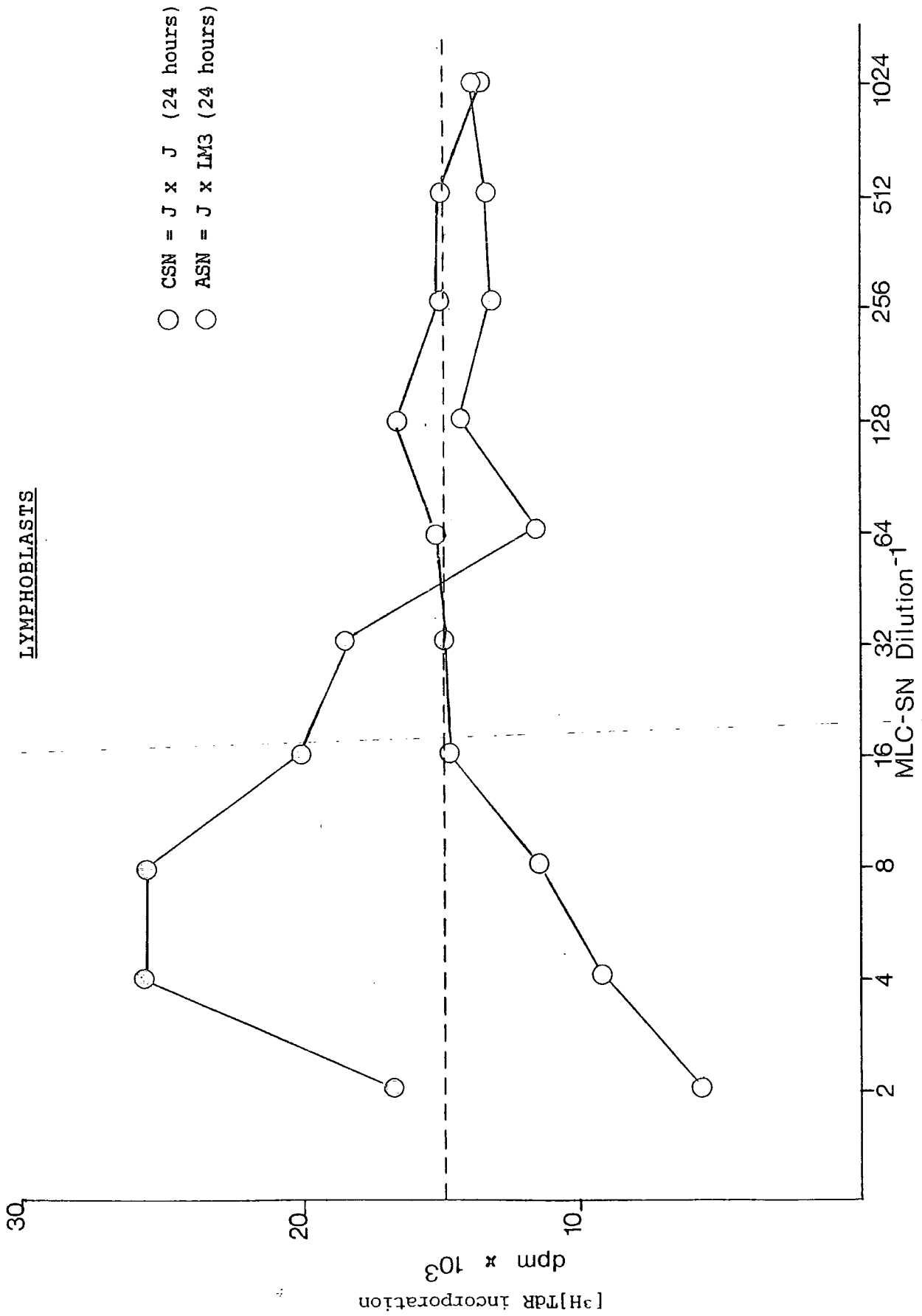

FIG. 2.3

LM3 splenocytes were PHA-M treated and cultured in 24-well flat-based tissue culture plates ( $4-5 \times 10^6$  leucocytes/ml) for 5 days in AL-15:FCS(10%). Cells were then ficoll-passed.

J splenocytes ( $4 \times 10^6$  leucocytes/ml/well) were cultured with 6000R irradiated LM3 splenocytes ( $2 \times 10^6$  cells/ml/well) for MLC-SN generation in AL-15:BSA. The MLC-SNs were removed at 4, 24, 48 and 120 hours after initiation of culture. [MLC-CSNs were J v. J<sup>R</sup> splenocytes.]

Assay cells (LM3:  $1 \times 10^5$  leucocytes/well) were dispensed into 96-well flat-based plates in AL-15:FCS(1%). MLC-SN was added to give a final "in well" concentration of 25% in a total volume of 200 $\mu$ l. Cultures were set up in triplicate. After 48 hours of culture, each well was pulsed with 1 $\mu$ Ci [<sup>3</sup>H]TdR and harvested 24 hours later.

The dotted line represents the dpm of assay cells cultured in medium alone.



FIG. 2.3 KINETICS OF SN PRODUCTION IN ONE-WAY MLC

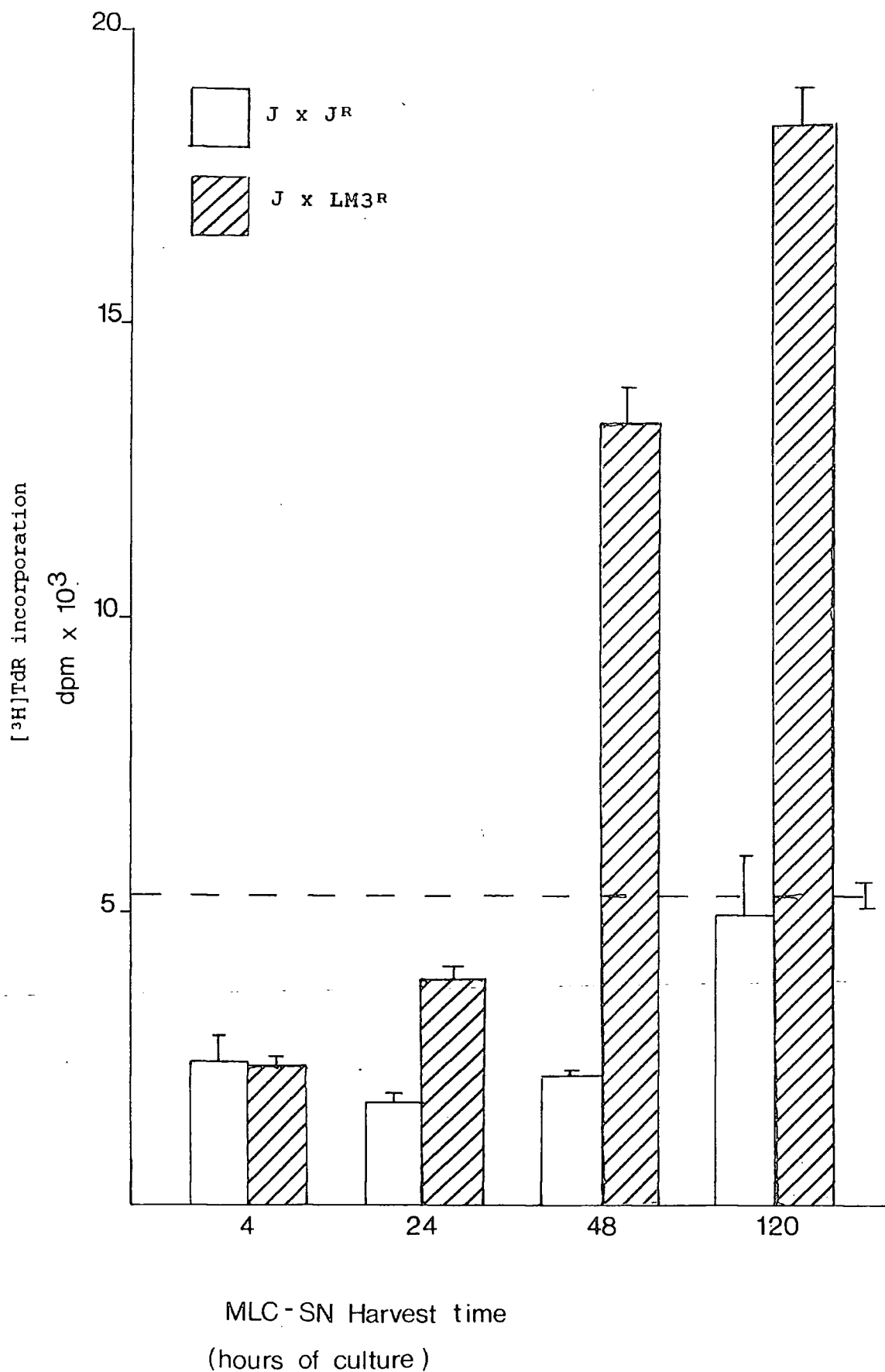

FIG. 2.4

Assay cells were LG15 splenocytes that were either "fresh" (i.e. taken and assayed straight from the animal), or were splenocytes that had been PHA-M treated and pre-cultured in 24-well flat-based tissue culture plates ( $4-5 \times 10^6$  leucocytes/ml) for 5 days in AL-15:FCS(10%). Splenocytes that had been precultured in AL-15:FCS(10%), without PHA, for 5 days were also used.

Assay cells ( $1 \times 10^5$  leucocytes/well) were dispensed into 96-well flat-based plates in AL-15:FCS(1%). In this experiment they were not Ficoll-passed. Three different MLC-SN (taken at different time points) were added to give a final "in well" concentration of 25% in a total volume of  $200\mu\text{l}$ . Cultures were set up in triplicate. After 48 hours of culture, each well was pulsed with  $1\mu\text{Ci}$  [ $^3\text{H}$ ]TdR and harvested 24 hours later.

The dotted line represents the dpm of assay cells cultured in medium alone.

FIG. 2.4

EFFECT OF ONE-WAY MLC-SNS ON "FRESH", 5 DAY MEDIUM PRECULTURED

AND 5 DAY PHA PRECULTURED LG15 SPLEEN CELLS

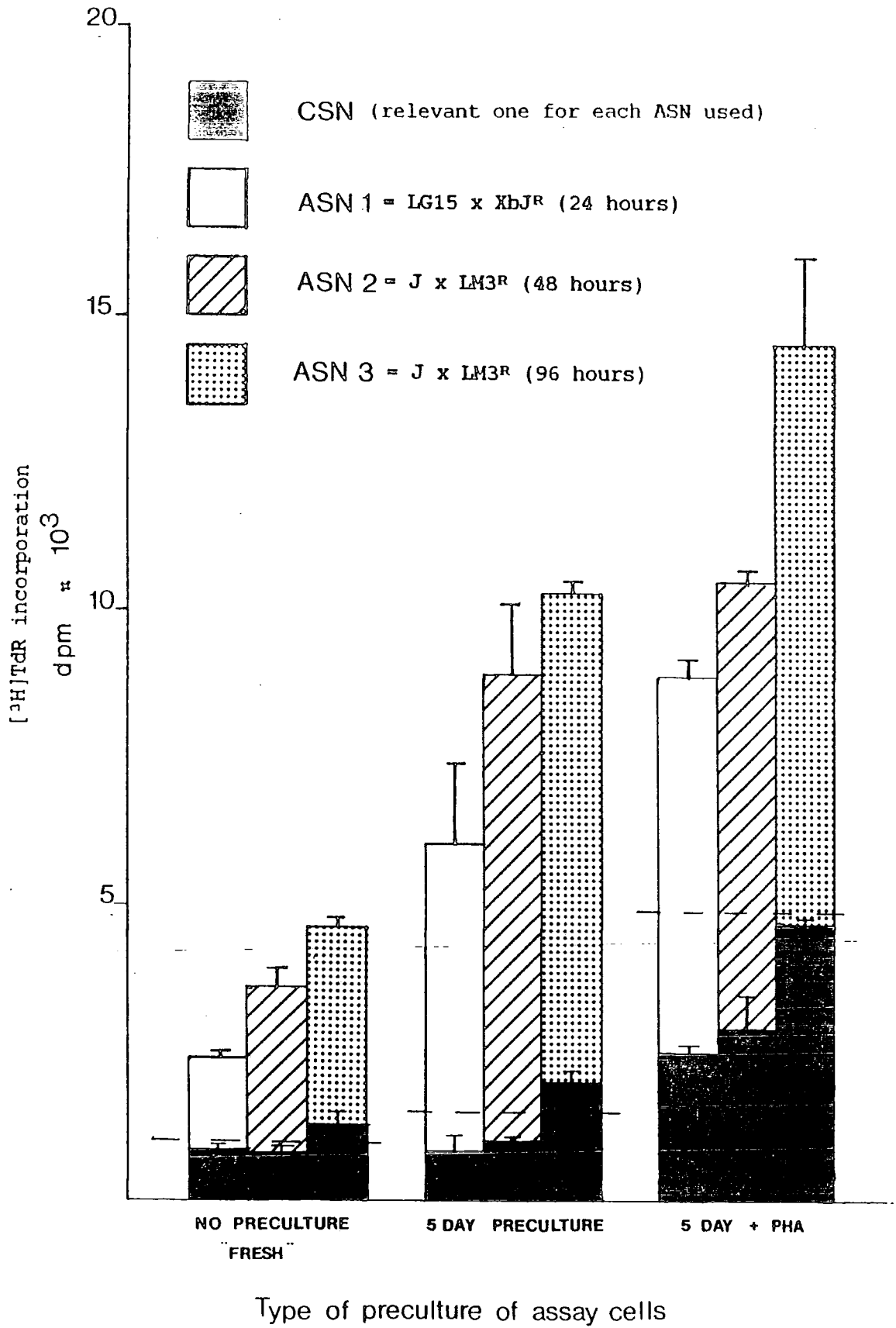

FIG. 2.5

Xb splenocytes were cultured in 24-well flat-based tissue culture plates ( $4-5 \times 10^6$  leucocytes/ml) for 5 days in AL-15:FCS(5%), with or without PHA-M. Cells were then washed and adjusted to  $2 \times 10^6$  leucocytes/ml and cultured in 1ml volumes in 24-well plates in AL-15:FCS(5%). Splenocytes were fed on day 0 and then every 4 days with 20% MLC-CSN or MLC-ASN. Viable leucocytes were counted on the days indicated on the graph.

FIG. 2.5 GROWTH OF *X. BOREALIS* SPLENCYTES FED MLC-ASNS OR MLC-CSNS

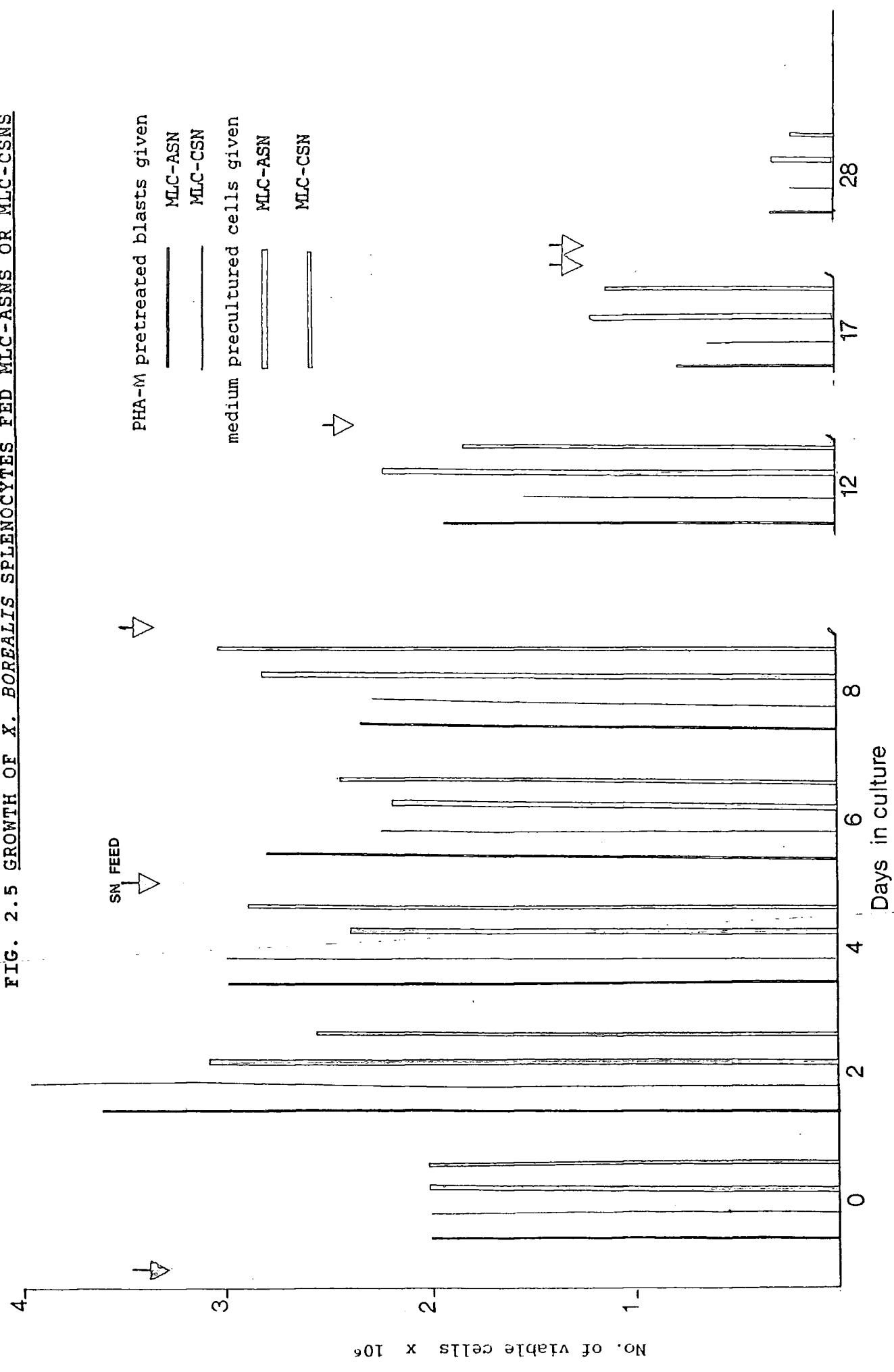

FIG. 2.6 and 2.7

Assay cells (LG5 thymocytes) were either "fresh" (taken and assayed straight from the animal) or LG5 thymocytes that had been PHA-M treated and cultured in 24-well flat-based tissue culture plates ( $4-5 \times 10^6$  leucocytes/ml) for 4 days.

Half of each "fresh" or PHA-M precultured population was cultured exclusively in AL-15:FCS (Fig. 2.6), the other half was cultured and assayed in AL-15:BSA exclusively (fig. 2.7).

A range of MLC-SN dilutions was made in 100 $\mu$ l volumes in a 96-well flat-based plate. 100 $\mu$ l aliquots of thymocyte cell suspension ( $1 \times 10^5$  leucocytes) were added to the SN dilutions.

After 48 hours of culture, each well was pulsed with 1 $\mu$ Ci [ $^3$ H]TdR and harvested 24 hours later.

The dotted line represents the dpm of assay cells cultured in medium alone.

FIG. 2.6 PROLIFERATIVE RESPONSES OF LG5 "FRESH" OR PHA TREATED THYMOCYTES TO

DIFFERENT DOSES OF SPLENOCYTE MLC-SNS: CULTURED IN AL-15:FCS

- CSN = J x JR (48hr)
- ⊙ ASN = J x LG15R (48hr)

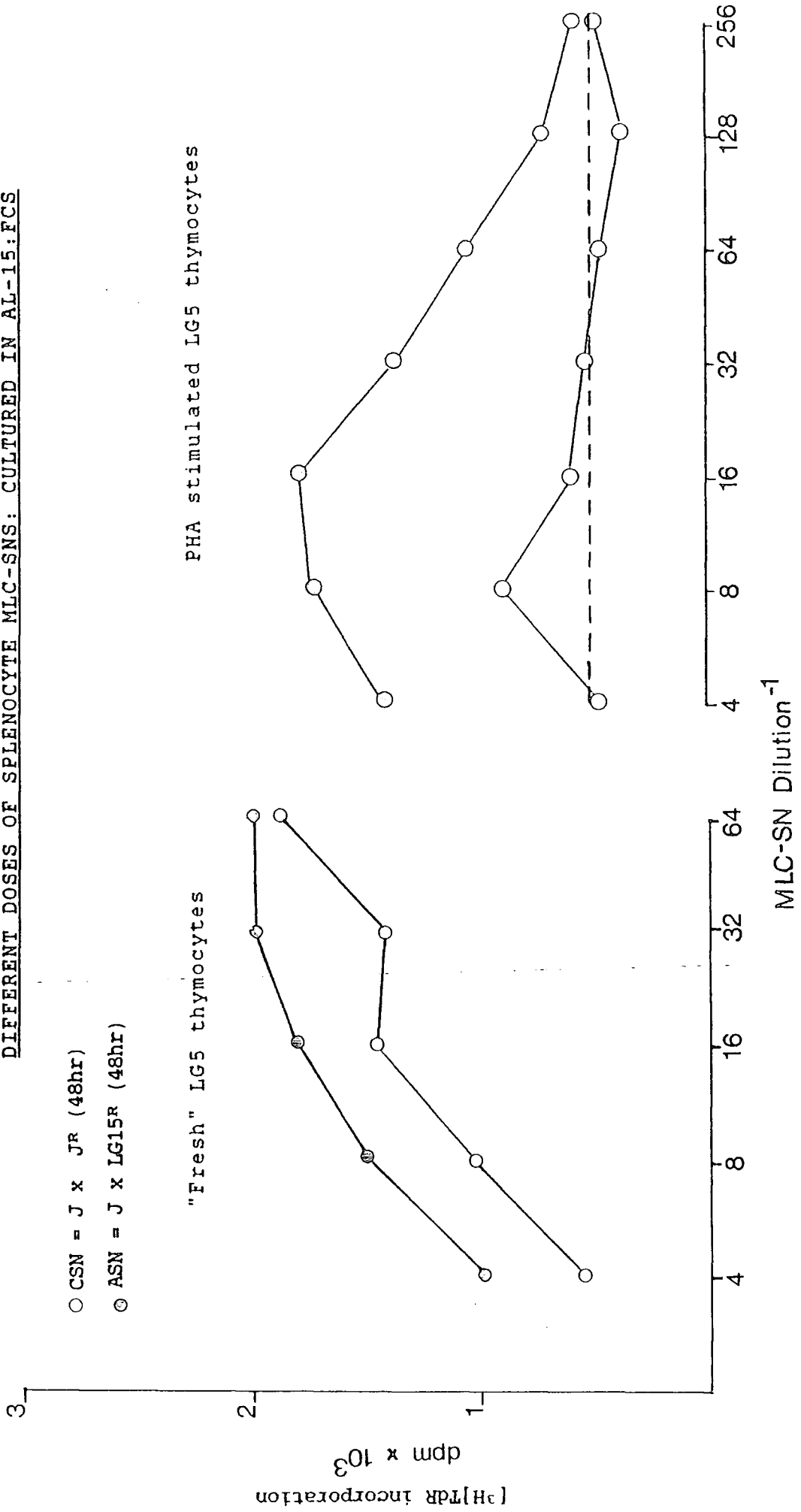

FIG. 2.7 PROLIFERATIVE RESPONSES OF LG5 "FRESH" OR PHA TREATED THYMOCYTES TO

DIFFERENT DOSES OF SPLENOCYTE MLC-SNS: CULTURED IN AL-15:BSA

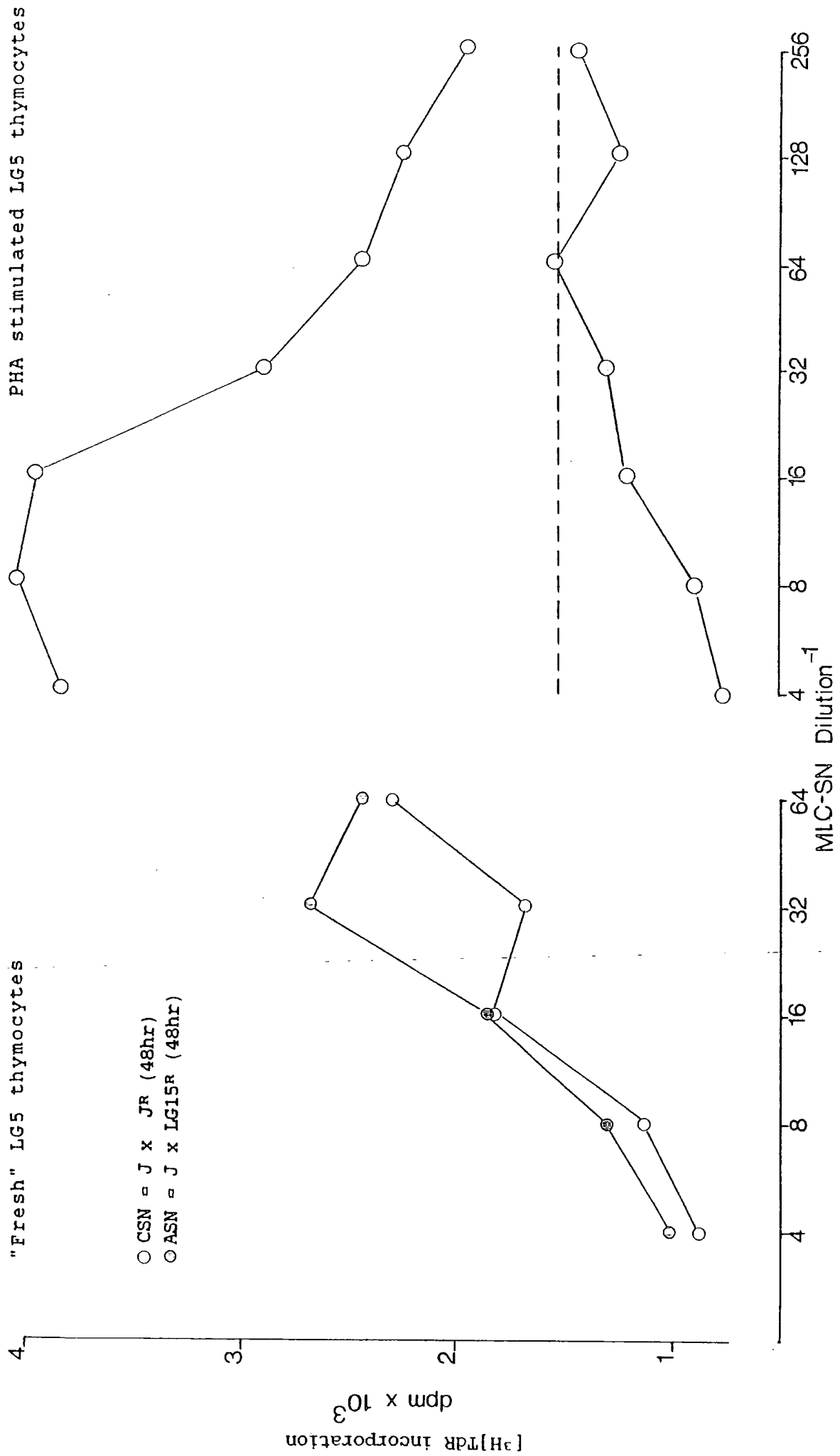



FIG. 2.8

Assay cells were LG5 thymocytes that had been cultured in AL-15:FCS in 24-well flat-based tissue culture plates ( $4-5 \times 10^6$  leucocytes/ml) for 4 days with or without PHA-M.

A range of MLC-SN dilutions was made in  $100\mu\text{l}$  volumes in a 96-well flat-based plate.  $100\mu\text{l}$  aliquots of thymocyte cell suspension ( $1 \times 10^5$  leucocytes) were added to the SN dilutions. Cultures were set up in duplicate.

After 48 hours of culture, each well was pulsed with  $1\mu\text{Ci}$  [ $^3\text{H}$ ]TdR and harvested 24 hours later.

The dotted line represents the dpm of assay cells cultured in medium alone.

FIG. 2.8 4 DAY PRETREATMENT OF ASSAY THYMOCYTES IN MEDIUM FAILS TO MAKE THEM

RESPONSIVE TO MLC-ASNS

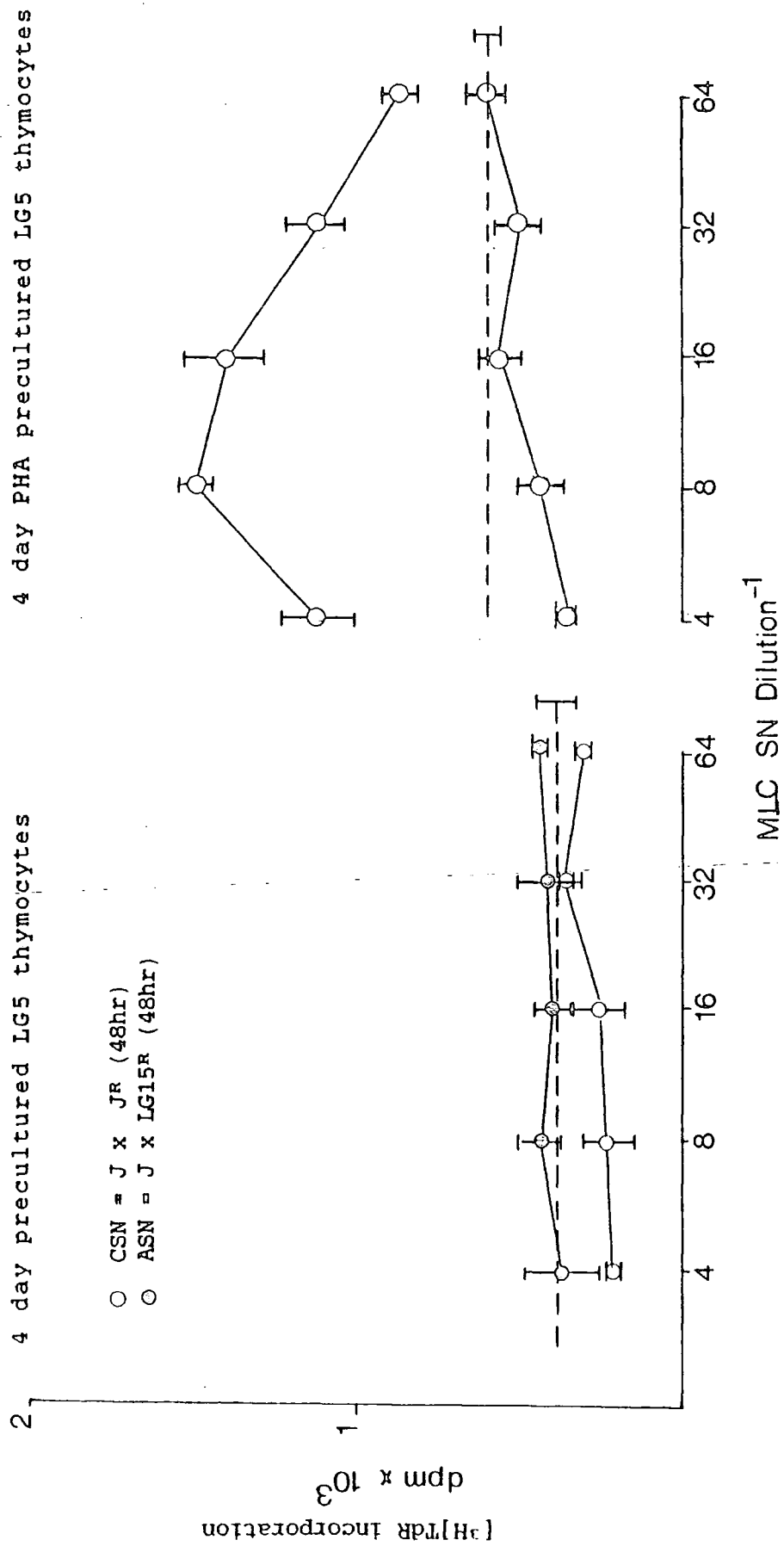

TABLE 2.1

Responder splenocytes ( $1 \times 10^5$  leucocytes/well) were cultured with 6000R irradiated stimulator splenocytes ( $0.5 \times 10^5$  leucocytes/well) in 96-well, V-based tissue culture plates. Splenocytes were in AL-15:BSA throughout and cultures were set up in triplicate. Each well was pulsed with  $1\mu\text{Ci}$  [ $^3\text{H}$ ]TdR 24 hours before harvesting.

Stimulation indices (SIs) were calculated using the following formula:

$$\text{SI} = \frac{\text{resp} \times \text{stim}^{\text{R}} - \text{stim}^{\text{R}}/2 \quad (\text{dpm})}{\text{resp} \times \text{resp}^{\text{R}} - \text{resp}^{\text{R}}/2 \quad (\text{dpm})}$$

[<sup>R</sup>] = irradiated cells

Each experiment employed responder cells from separate animals.

TABLE 2.1 KINETICS OF SPLENOCYTE ONE-WAY MLC IN AL-15:BSA

| Expt | Responder | 6000R irradiated stimulator | Days in culture         |                      |                      |                       |                       |
|------|-----------|-----------------------------|-------------------------|----------------------|----------------------|-----------------------|-----------------------|
|      |           |                             | 1                       | 2                    | 3                    | 4                     | 5                     |
|      |           |                             | mean dpm $\pm$ sem [SI] |                      |                      |                       |                       |
| 1    | LM3       | LM3                         | n.d.                    | n.d.                 | 1445 $\pm$ 83        | 3017 $\pm$ 265        | 5926 $\pm$ 266        |
|      | LM3       | LG15                        | n.d.                    | n.d.                 | 4282 $\pm$ 328 [2.9] | 9325 $\pm$ 526 [3.1]  | 12566 $\pm$ 364 [2.1] |
| 2    | LM3       | LM3                         | 1009 $\pm$ 75           | 1834 $\pm$ 35        | n.d.                 | 13098 $\pm$ 53        | 14026 $\pm$ 420       |
|      | LM3       | LG15                        | 1114 $\pm$ 24 [1.1]     | 3019 $\pm$ 167 [1.7] | n.d.                 | 29855 $\pm$ 226 [2.3] | 36528 $\pm$ 339 [2.6] |
| 3    | J         | J                           | n.d.                    | n.d.                 | n.d.                 | 695 $\pm$ 135         | n.d.                  |
|      | J         | LM3                         | n.d.                    | n.d.                 | n.d.                 | 3461 $\pm$ 115 [5.4]  | n.d.                  |
| 4    | J         | J                           | n.d.                    | n.d.                 | n.d.                 | 1208 $\pm$ 65         | n.d.                  |
|      | J         | LM3                         | n.d.                    | n.d.                 | n.d.                 | 3017 $\pm$ 172 [2.5]  | n.d.                  |

TABLE 2.2

LM3 responder splenocytes ( $1 \times 10^5$  leucocytes/well) were cultured with 6000R irradiated LG15 stimulator splenocytes ( $0.5 \times 10^5$  leucocytes/well) in 96-well, V-based tissue culture plates, using AL-15:FCS(1%). Medium (AL-15:BSA), MLC-ASN or MLC-CSN was added to bring the final SN concentration to 25% in a total volume of  $200\mu\text{l}$ . Cultures were set up in triplicate. After 72 hours of culture each well was pulsed with  $1\mu\text{Ci}$  [ $^3\text{H}$ ]TdR and harvested 24 hours later.

Stimulation indices (SIs) were calculated using the following formula:

$$\text{SI} = \frac{\text{resp} \times \text{stim}^{\text{R}} + \text{med/CSN/ASN (dpm)}}{\text{resp} \times \text{resp}^{\text{R}} + \text{med/CSN/ASN (dpm)}}$$

except \*

$$*\text{SI} = \frac{\text{LM3 alone} + \text{ASN (dpm)}}{\text{LM3 alone} + \text{CSN (dpm)}}$$

TABLE 2.2 INABILITY OF MLC-ASNS TO COSTIMULATE ONE-WAY SPLENCYCYTE MLC

| Expt | Responder | 6000R irradiated stimulator | Splenocytes cultured with: |                       |                        | mean dpm $\pm$ sem [SI] |
|------|-----------|-----------------------------|----------------------------|-----------------------|------------------------|-------------------------|
|      |           |                             | Medium                     | CSN                   | ASN                    |                         |
| 1    | LM3       | LM3                         | 13098 $\pm$ 53             | 6251 $\pm$ 356        | 14143 $\pm$ 745        |                         |
|      | LM3       | LG15                        | 29885 $\pm$ 2261 [2.3]     | 14783 $\pm$ 781 [2.4] | 17402 $\pm$ 1390 [1.2] |                         |
| 2    | LM3       | LM3                         | 14061 $\pm$ 21             | 9783 $\pm$ 476        | 16251 $\pm$ 815        |                         |
|      | LM3       | LG15                        | 21668 $\pm$ 95 [1.5]       | 12820 $\pm$ 338 [1.3] | 14237 $\pm$ 357 [0.9]  |                         |
|      | LM3       | NONE                        | 11797 $\pm$ 698            | 9763 $\pm$ 105        | 15912 $\pm$ 490 [1.6]* |                         |

CSN = J x JR (48hr)  
 ASN = J x LM3R (48hr)

TABLE 2.3

Assay cells were 5 day PHA-M treated LG17 splenocytes raised in AL-15:FCS(10%) in 24-well flat-based tissue culture, then passed over Ficoll. LG17 blasts were dispensed into 96-well flat-based tissue-culture plates in AL-15:FCS(1%) and given MLC-SN immediately or pre-cultured for an additional 24 hours before receiving MLC-SN. LG blasts ( $1 \times 10^5$  leucocytes/well) received a final SN concentration of 25% in a total volume of 200 $\mu$ l. Cultures were set up in triplicate.

After 48 hours of culture (with SN) each well was pulsed with 1 $\mu$ Ci [ $^3$ H]TdR and harvested 24 hours later.

$$\text{SI} = \frac{\text{MLC-ASN (dpm)}}{\text{MLC-CSN (dpm)}}$$

TABLE 2.3 EFFECT OF 24 HOUR "PRECULTURE" OF SPLENIC LYMPHOBLASTS ON  
RESPONSIVITY TO MLC-SNS

| Pretreatment<br>of LG17<br>assay cells | Medium     | Splenocytes cultured with:           |                                      |                                      |
|--|------------|--------------------------------------|--------------------------------------|--------------------------------------|
|  |            | CSN <sup>1</sup><br>ASN <sup>1</sup> | CSN <sup>2</sup><br>ASN <sup>2</sup> | CSN <sup>3</sup><br>ASN <sup>3</sup> |
| mean dpm ± sem<br>[SI]                 |            |                                      |                                      |                                      |
| A                                      | 2143 ± 140 | 1814 ± 91                            | 1873 ± 98                            | 2060 ± 81                            |
|  |            | 18475 ± 2017<br>[10.2]               | 5774 ± 140<br>[3.1]                  | 6871 ± 193<br>[3.3]                  |
| B                                      | 1099 ± 146 | 1115 ± 29                            | 1212 ± 48                            | 977 ± 77                             |
|  |            | 7493 ± 311<br>[6.7]                  | 4122 ± 98<br>[3.4]                   | 3407 ± 160<br>[3.5]                  |

Treatment A = 5 days pretreatment with PHA.  
 Treatment B = " " " " and 24hrs additional  
 preculture in 96-well assay plate.  
 CSN<sup>1</sup> = J x JR ASN<sup>1</sup> = J x LM3R  
 CSN<sup>2</sup> = J x JR ASN<sup>2</sup> = J x LG15R  
 CSN<sup>3</sup> = LG17 x LG17R ASN<sup>3</sup> = LG17 x XbJR  
 All SNs harvested at 24 hours



TABLE 2.4

Splenocytes were PHA-M treated and cultured in tubes (4-5 x 10<sup>6</sup> leucocytes/ml) for 3-5 days or in 24-well flat-based plates (4-5 x 10<sup>6</sup> leucocytes/ml) for 5 days in AL-15:FCS(10%). Cells were then Ficoll-passed.

Assay cells (1 x 10<sup>5</sup> leucocytes/well) were dispensed into 96-well flat-based plates in AL-15:FCS(1%). SN was added to give a final "in well" concentration of 25% in a total volume of 200 $\mu$ l. Cultures were set up in triplicate. After 48 or 72 hours of culture each well was pulsed with 1 $\mu$ Ci [<sup>3</sup>H]TdR and harvested 24 hours later.

$$\text{SI} = \frac{\text{MLC-ASN (dpm)}}{\text{MLC-CSN (dpm)}}$$

TABLE 2.4 COMPARISON OF ABILITY OF "TUBE" OR "PLATE"-GENERATED SPLENIC BLASTS TO RESPOND TO ONE-WAY MLC-SNS

| Culture time for generation of blasts (days) | Length of (XbJ) blast SN assay generation (days) | Medium       | Assay cells cultured with:                                |                                       |                                      |
|--|--|--------------|---|---------------------------------------|--------------------------------------|
|  |  |              | CSN <sup>1</sup><br>ASN <sup>1</sup><br>dpm ± sem<br>[SI] | CSN <sup>2</sup><br>ASN <sup>2</sup>  | CSN <sup>3</sup><br>ASN <sup>3</sup> |
| 3  | tube   | 23842 ± 350  | 10294 ± 510   | 10902 ± 351                           | 6717 ± 1285                          |
|  |  |              | 18063 ± 598<br>[2.3]                                      | 18063 ± 598<br>[1.7]                  | 37290 ± 1236<br>[5.6]                |
| 5  | tube   | 56029 ± 3455 | 28103 ± 1684<br>45290 ± 1726<br>[1.6]                     | 34986 ± 2355<br>37124 ± 1050<br>[1.1] | n.d.                                 |
| 5  | plate  | 2715 ± 114   | 1394 ± 69<br>6082 ± 65<br>[4.4]                           | 1712 ± 148<br>5480 ± 315<br>[3.2]     | 1036 ± 181<br>11544 ± 737<br>[11.0]  |
| 3  | tube   | 12469 ± 531  | 5183 ± 260  | 5810 ± 352                            | 3657 ± 355                           |
|  |  |              | 12793 ± 227<br>[2.5]                                      | 14043 ± 1790<br>[2.4]                 | 27117 ± 222<br>[7.4]                 |
| 5  | tube   | 24407 ± 1125 | 15440 ± 889<br>24320 ± 1827<br>[1.6]                      | 19910 ± 1561<br>24059 ± 1577<br>[1.2] | n.d.                                 |
| 5  | plate  | 2143 ± 241   | 1021 ± 108<br>3779 ± 200<br>[3.7]                         | 1061 ± 103<br>3839 ± 61<br>[3.6]      | 624 ± 48<br>8110 ± 95<br>[12.9]      |

CSN<sup>1</sup> = LG17 x LG17R (24 hours)      ASN<sup>1</sup> = LG17 x XbJR (24 hours)  
 CSN<sup>2</sup> = LG17 x LG17R (48 hours)      ASN<sup>2</sup> = LG17 x XbJR (48 hours)  
 CSN<sup>3</sup> = J x JR (24 hours)              ASN<sup>3</sup> = J x LM3R (24 hours)

TABLE 2.5

Splenocytes of different genotypes were PHA-M treated and cultured in 24-well flat-based tissue culture plates ( $4-5 \times 10^6$  leucocytes/ml) for 5 days in AL-15:FCS(10%). Cells were then ficoll-passed.

Assay cells ( $1 \times 10^5$  leucocytes/well) were dispensed into 96-well flat-based plates in AL-15:FCS(1%). SN was added to give a final "in well" concentration of 25% in a total volume of  $200\mu\text{l}$ . Cultures were set up in triplicate. After 48 hours of culture each well was pulsed with  $1\mu\text{Ci}$  [ $^3\text{H}$ ]TdR and harvested 24 hours later.

$$\text{SI} = \frac{\text{MLC-ASN (dpm)}}{\text{MLC-CSN (dpm)}}$$

TABLE 2.5 ABILITY OF ONE-WAY MLC-SNS TO STIMULATE BLAST CELL POPULATIONS OF  
VARIOUS GENOTYPES

| Blast cell origin   | medium                                |                                      |  | Cells cultured with:                    |  |      |
|---------------------|---------------------------------------|--------------------------------------|--|---|--|------|
|                     |                                       | CSN <sup>1</sup><br>ASN <sup>1</sup> | CSN <sup>2</sup><br>ASN <sup>2</sup><br>mean dpm ± sem<br>[SI] | CSN <sup>3</sup><br>ASN <sup>3</sup>    |  |      |
| Responder<br>J      | 8331 ± 552                            | 4046 ± 318<br>12346 ± 164<br>[3.0]   | 5609 ± 603<br>23489 ± 877<br>[4.2]                             | 6245 ± 385<br>22185 ± 1179<br>[3.6]     |  |      |
| Stimulator<br>LM3   | 5225 ± 199                            | 1744 ± 139<br>3779 ± 269<br>[2.2]    | 2170 ± 197<br>13229 ± 60<br>[6.1]                              | 4974 ± 1184<br>18279 ± 532<br>[3.7]     |  |      |
| Third party<br>LG15 | 4906 ± 241                            | n.d.                                 | 2924 ± 129<br>10524 ± 90<br>[3.6]                              | n.d.                                    |  | n.d. |
|                     | CSN <sup>1</sup> = J x JR (24 hours)  |                                      |  | ASN <sup>1</sup> = J x LM3R (24 hours)  |  |      |
|                     | CSN <sup>2</sup> = J x JR (48 hours)  |                                      |  | ASN <sup>2</sup> = J x LM3R (48 hours)  |  |      |
|                     | CSN <sup>3</sup> = J x JR (120 hours) |                                      |  | ASN <sup>3</sup> = J x LM3R (120 hours) |  |      |

TABLE 2.6

Splenocytes were PHA-M treated and cultured in 24-well flat-based tissue culture plates ( $4-5 \times 10^6$  leucocytes/ml) for 5 days in AL-15:FCS(10%). Cells were then ficoll-passed.

Assay cells ( $1 \times 10^5$  leucocytes/well) were dispensed into 96-well flat-based plates in AL-15:FCS(1%). The MLC-SNs were from either a one-way (i.e. stimulators were 6000R irradiated) or from a two-way (i.e. stimulators not irradiated) MLC. SN was added to give a final "in well" concentration of 25% in a total volume of  $200\mu\text{l}$ . Cultures were set up in triplicate.

After 48 hours of culture each well was pulsed with  $1\mu\text{Ci}$  [ $^3\text{H}$ ]TdR and harvested 24 hours later.

$$\text{SI} = \frac{\text{MLC-ASN (dpm)}}{\text{MLC-CSN (dpm)}}$$

TABLE 2.6 PRODUCTION OF INHIBITORY SNS BY CONTROL CULTURES IN THE ABSENCE OR PRESENCE OF IRRADIATED SYNGENEIC CELLS

| Origin of assay blasts | Assay cells cultured in the presence of: |                                   |                                      |                        |
|------------------------|--|-----------------------------------|--------------------------------------|------------------------|
|                        | medium                                   | one-way MLC*                      | two-way MLC**                        |                        |
|                        |  | CSN<br>ASN                        | CSN<br>ASN                           | mean dpm ± sem<br>[SI] |
| J                      | 3797 ± 18                                | 3080 ± 162<br>7226 ± 433<br>[2.3] | 1864 ± 117<br>21028 ± 1915<br>[11.3] |                        |
| LM3                    | 8801 ± 44                                | 4284 ± 90<br>n.d.                 | 3470 ± 177<br>n.d.                   |                        |

\* = stimulators 6000R irradiated

\*\* = stimulators not irradiated

TABLE 2.7

LG15 splenocytes were PHA-M treated and cultured in 24-well flat-based tissue culture plates ( $4-5 \times 10^6$  leucocytes/ml) for 5 days in AL-15:FCS(10%). These assay cells were then ficoll-passed. Assay cells ( $1 \times 10^5$  viable leucocytes/well) were dispensed into 96-well flat-based plates in AL-15:FCS(1%).

The 24hr MLC-SNs were from LG15 responder leucocytes that had been generated in either "fresh" or "conditioned" media. Medium was conditioned by culturing LG15 leucocytes ( $2 \times 10^6$  leucocytes/ml) in flasks with AL-15:BSA for 5 days, the conditioned medium was collected and used in the generation of MLC-SNs.

SN was added to give a final "in well" concentration of 25% in a total volume of  $200\mu\text{l}$ . Cultures were set up in triplicate. After 48 hours of culture, each well was pulsed with  $1\mu\text{Ci}$  [ $^3\text{H}$ ]TDR and harvested 24 hours later.

$$\text{SI} = \frac{\text{MLC-ASN (dpm)}}{\text{MLC-CSN (dpm)}}$$

TABLE 2.7 COMPARISON OF SNS GENERATED IN FRESH MEDIUM OR IN 5 DAY  
CONDITIONED MEDIUM

| Origin of<br>blasts | medium         | Assay cell treatment:                   |  | mean dpm $\pm$ sem<br>[SI] |
|---------------------|----------------|---|--|----------------------------|
|                     |                | CSN <sup>1</sup><br>ASN <sup>1</sup>    | CSN <sup>2</sup><br>ASN <sup>2</sup>     |                            |
| LG15                | 2440 $\pm$ 204 | 1520 $\pm$ 33<br>1556 $\pm$ 20<br>[1.0] | 1370 $\pm$ 75<br>8465 $\pm$ 101<br>[6.1] |                            |

CSN<sup>1</sup> = LG15xLG15R(fresh med) ASN<sup>2</sup> = LG15XXBR(5-day conditioned med)  
 CSN<sup>2</sup> = LG15xLG15R(5-day conditioned med)ASN<sup>1</sup> = LG15XXBR(fresh med)  
 All SNS were collected at 24 hours after initiation of culture.



TABLE 2.8

Assay splenocytes were PHA-M treated and cultured in 24-well flat-based tissue culture plates ( $4-5 \times 10^6$  leucocytes/ml) for 5 days in AL-15:FCS(10%). Cells were then ficoll-passed.

The MLC-SNs were generated from *J Xenopus* that had either been given an autograft (*J* skin) or an allograft (LM3 skin). At the end point of allograft skin rejection, spleens were removed and the splenocytes set up for one-way MLC-SN generation.

Assay cells ( $1 \times 10^5$  leucocytes/well) were dispensed into 96-well flat-based plates in AL-15:FCS(1%). MLC-SN was added to give a final "in well" concentration of 25% in a total volume of  $200\mu\text{l}$ . Cultures were set up in triplicate. After 48 hours of culture, each well was pulsed with  $1\mu\text{Ci}$  [ $^3\text{H}$ ]TdR and harvested 24 hours later.

$$\text{SI} = \frac{\text{MLC-ASN (dpm)}}{\text{MLC-CSN (dpm)}}$$

TABLE 2.8 EFFECT OF PRIOR SKIN GRAFTING ON SPLENOCYTE MLC-SN PRODUCTION

| Origin of SN | SN harvest time | Origin of blasts used in assay | Assay cell treatment:      |                  |                                 | SI   |
|--------------|-----------------|--------------------------------|----------------------------|------------------|---------------------------------|------|
|              |                 |                                | Host (graft donor) (hours) | medium           | CSN (J x JR) mean dpm $\pm$ sem |      |
| J (J)        | 24              | J                              | 2823 $\pm$ 199             | 457 $\pm$ 17     | 2351 $\pm$ 161                  | 5.1  |
| J (LM3)      |                 |                                |                            | 467 $\pm$ 50     | 6056 $\pm$ 481                  | 13.3 |
| J (J)        | 24              | LM3                            | 25462 $\pm$ 747            | 19961 $\pm$ 712  | 36017 $\pm$ 1077                | 1.8  |
| J (LM3)      |                 |                                |                            | 26410 $\pm$ 1461 | 61871 $\pm$ 2346                | 2.3  |
| J (J)        | 24              |                                |                            | 4617 $\pm$ 286   | 11177 $\pm$ 441                 | 2.4  |
| J (LM3)      |                 |                                |                            | 4854 $\pm$ 174   | 19532 $\pm$ 998                 | 4.0  |
| J (J)        | 96              | LG15                           | 12875 $\pm$ 531            | 10728 $\pm$ 84   | 26637 $\pm$ 4344                | 2.5  |
| J (LM3)      |                 |                                |                            | 7849 $\pm$ 422   | 37292 $\pm$ 479                 | 4.4  |

TABLE 2.9

J and LG5 thymocytes ( $3 \times 10^6$  leucocytes/well) were set up in a two-way MLC in AL-15:BSA in 24-well flat-based plates. Control cultures of J x J and LG5 x LG5 were also established. [Splenocytes from these same animals were also set up for SN generation in an identical manner.] After 48 hours the MLC-SN was collected and immediately the thymocytes were readjusted to  $1 \times 10^6$  leucocytes/ml in AL-15:BSA. 100 $\mu$ l aliquots of cells from the control (J x J or LG5 x LG5) and experimental (J X LG5) cultures of thymocytes were then dispensed into 96-well flat-based tissue culture plates. Cultures were set up in triplicate. Each well was pulsed immediately with 1 $\mu$ Ci [ $^3$ H]TdR and harvested 24 hours later (Results shown in [A]).

experimental culture (dpm)

$$\text{SI} = \frac{\text{experimental culture (dpm)}}{\text{control 1} + \text{control 2} / 2 \text{ (dpm)}}$$

(B) The thymocyte and splenocyte MLC-SNs generated at 48 hours from the cells in (A) were assayed for their ability to stimulate *X.laevis* splenocytes in this experiment, using the Terasaki miniaturisation technique (see Chapter 4).

*X.laevis* splenocytes ( $1.5 \times 10^4$  leucocytes/well) were dispensed into Terasaki plates. 5 $\mu$ l MLC-SN was added to

bring the final "in well" SN concentration of 25% in a volume of 20 $\mu$ l. Cultures were set up in replicates of five. After 48 hours of culture, each well was pulsed with 0.2 $\mu$ Ci [ $^3$ H]TdR and harvested 20 hours later.

For the thymocyte cultures:-

$$\text{SI} = \frac{\text{experimental culture (dpm)}}{\text{control 1} + \text{control 2} / 2 \text{ (dpm)}}$$

For the splenocyte cultures:

$$\text{SI} = \frac{\text{experimental culture (dpm)}}{\text{assay cells in medium (dpm)}}$$

TABLE 2.9 A ABILITY OF THYMOCYTES TO RESPOND IN MLC

MLC thymocyte combination:

| J x J          | LG5 x LG5  | J x LG5    | SI  |
|----------------|------------|------------|-----|
| mean dpm ± sem |            |            |     |
| 1143 ± 61      | 1723 ± 191 | 2105 ± 102 | 1.5 |

TABLE 2.9 B EFFECT OF SN FROM TWO-WAY THYMOCYTE AND SPLENOCYTE MLC ON SPLENOCYTE PROLIFERATION

Assay cell Assay cells cultured in the presence of SNs generated from:

| medium    | THYMOCYTES     |          | SPLENOCYTES    |           |
|-----------|----------------|----------|----------------|-----------|
| -----     | CSN            | J x J    | ASN            | J x LG5   |
|           | mean dpm ± sem |          | mean dpm ± sem |           |
|           | [SI]           |          | [SI]           |           |
| X. Jaavis | 166 ± 14       | 117 ± 41 | 152 ± 51       | 1389 ± 41 |
|           |                |          | [0.8]          | [8.4]     |

TABLE 2.10

Thymocytes ( $1 \times 10^5$  leucocytes/well) were dispensed into 96-well flat-based plates in AL-15:FCS(1%). MLC-SN, PHA-P and/or medium was added to give a final "in well" concentration of 25% MLC-SN and/or 0.02ug/ml PHA-P in a total volume of 200 $\mu$ l. Cultures were set up in triplicate. After 48 hours of culture, each well was pulsed with 1 $\mu$ Ci [ $^3$ H]TdR and harvested 24 hours later.

TABLE 2.10 THYMOCYTE COSTIMULATION ASSAYS

| Thymocyte origin | Thymocytes cultured in presence of: |                             |            |                       | mean dpm ± sem [SI] |
|------------------|-------------------------------------|-----------------------------|------------|-----------------------|---------------------|
|                  | medium                              | sub-optimal PHA (0.02µg/ml) | CSN* ASN*  | CSN* + PHA ASN* + PHA |                     |
| Xb               | 844 ± 97                            | 3252 ± 177 [3.8]            | 315 ± 18   | 1229 ± 59             |                     |
|                  |                                     |                             | 747 ± 37   | 1925 ± 138            |                     |
| LG15/wild        | 2964 ± 282                          | 4482 ± 197 [1.5]            | 1109 ± 58  | 1780 ± 99             |                     |
|                  |                                     |                             | 2032 ± 146 | 6320 ± 239            |                     |
| LG5              | 3971 ± 281                          | 7430 ± 542 [1.9]            | 2120 ± 130 | 5027 ± 296            |                     |
|                  |                                     |                             | 1915 ± 31  | 6475 ± 31             |                     |

\* = SN from splenocyte MLC (JxLM3848nc)

## 2.4 DISCUSSION

Detailed investigations into the nature of cytokines produced during an MLC response in *Xenopus* have not previously been attempted (see introduction). The present studies reveal that mitotic factors are routinely released during coculture of allogeneic splenocytes from 1-2 year old *Xenopus laevis*. Such active supernatants can cause the proliferation of splenic lymphoid assay cells, as measured by tritiated thymidine uptake. Activity of the ASNs was first detected at 24hrs; a marked increase in activity occurred at 48hrs and persisted up to 120hrs. These kinetics are similar to those obtained in the murine MLC (Puré, Inaba & Metlay, 1988). Concomitant with the increasing level of SN activity in the MLC is an increased proliferation of the cells involved in the MLC. This MLC-induced cell proliferation is first noticeable at 48hrs, increasing to reach a peak at 72 and 96hrs of culture. Thus there appears to be a correlation between the kinetics of the accumulation of mitotic factors in the SN and the onset and continuation of a proliferative cellular response in MLC. When MLC generated ASNs were added to splenocytes themselves set up in MLC, the MLC response was not enhanced. This suggests that adequate factors are released by the participating splenocytes to give a fully competent MLC response in the absence of exogenous MLC-ASN.

The nature of the assay cell types capable of responding directly by enhanced proliferation when given MLC-ASNs was investigated here in some depth. Watkins and Cohen (1987) generated assay cells that were PHA-stimulated mixtures



of splenocytes from outbred *Xenopus laevis*: this produced T cell blasts of mixed haplotypes. In this Chapter it was decided to explore whether there was any genetic restriction in the ability to respond to splenic MLC-ASNs and therefore assay cells from different genetic stocks were not mixed. 5 day old blasts, that had been generated in 24-well flat-based plates were routinely used in these assays. Splenoblasts assayed any earlier than 5 days gave extremely high background thymidine counts, which made interpretation of the data difficult. All previous studies of MLC-SNs have used animals with undefined MHC haplotypes. Thus the question of whether cytotoxins were produced against the stimulator type had not been properly addressed. Experiments using MHC defined animals and one-way MLC showed that a one-way MLC-SN promoted the proliferation of assay cells (splenic lymphoblasts) of the stimulator and responder haplotypes as well as third party blasts. Thus it appears that the mitotic factors in the ASNs are non-haplotype specific.

One of the major findings of this Chapter has been that the MLC-ASNs induced proliferation of non PHA-treated (both "fresh" and medium-precultured) splenocytes equally as well as PHA-induced splenoblasts. These results are at variance with those obtained by Watkins and Cohen, who revealed that splenic blasts, but not splenocytes, responded to PHA-induced and alloantigen-induced crude SNs. There are a number of explanations for our findings, as follows:-

Firstly there is the possibility that *in vivo* stimulation of leucocytes of animals used here has occurred, thereby inducing the expression of the appropriate TCGF

receptors on the immunocyte surfaces. This could have been achieved through, for example, some chronic infection in our amphibian colony. However, all the *Xenopus* used appeared healthy and showed no signs of any disease. Secondly, the ability of medium (FCS supplemented)-precultured splenocytes to respond to MLC-ASNs could be due to *in vitro* stimulatory effects of the serum we used. Work on mammals has shown that the mitotic growth signal to push cells from  $G_0$ - $G_1$  can be regulated by serum components (Herzberg & Smith, 1987). This  $G_0$ - $G_1$  phase is coincident with the expression of high affinity IL-2 receptors. Subsequent progression through  $G_1$ -S phase (DNA synthesis) is entirely dependent on IL-2 (Herzberg & Smith, 1987). If a similar serum protein regulation exists in *Xenopus*, then this could account for the ability of cells cultured in AL-15:FCS(10%) for 5 days, to respond to ASN.

Although in mice there is normally a background of only 2-3% of cells bearing activation antigens, including high affinity IL-2R, in the absence of external antigenic stimulation (Shapiro, 1988), there is evidence that the situation in "unstimulated" *Xenopus* leucocytes might be different. Thus, in a recent report (Ruben *et al*, 1989b) it is claimed that human anti-IL-2 receptor (anti-TAC) antibody will bind 15-20% of splenocytes taken directly from non-immunised *Xenopus*. This observation is, however, controversial, as there is dispute over whether the human anti-IL2 receptor antibody recognises a functional IL-2R epitope on *Xenopus* cells (N. Cohen, BSI and BSDB conference, Durham, 1987).

There is yet another, more likely, possibility for the

induced proliferation of splenocytes achieved by MLC-ASNs in our experiments. Since crude MLC-ASNs are used, it would be expected that a variety of growth factors, additional to IL-2-like molecules are present. These factors may act on various splenocyte subsets, e.g. B cells, causing their enhanced proliferation. In mammals it has been demonstrated that a variety of cytokines are produced during a MLC response, e.g. IL-1, IL-4, B cell growth factor (BCGF), colony stimulating factor (CSF) and gamma-interferon ( $\gamma$ -IFN) (Puré, Inaba & Metlay, 1988; Trinchieri & Perussia, 1985; Hagiwara *et al*, 1987).

Another apparent difference between the present experiments using MLC-ASNs and those of Watkins and Cohen (using PHA-ASNs) is that no substantial increase in numbers of splenic blasts (or non-PHA treated splenocytes) was observed when attempts were made to restimulate and grow them using MLC-ASNs. Watkins and Cohen (1987) were able to show growth of blasts only when large amounts (PHA-ASN made up a third of the medium, in which the lymphoblasts were cultured) of PHA-derived SN were used. Thus it is possible that there may have been insufficient amounts of growth factor in the MLC-ASNs generated here, even though these SNs had previously been shown to cause proliferation of blasts in a 3 day assay.

The effect of irradiation on the production and activity of MLC-SNs was also probed. CSNs from syngeneic cultures, established with and without irradiated cells, both reduced thymidine incorporation of assay cells to below that of background (medium control) levels. It thus seemed unlikely that irradiation alone caused the observed inhibitory effect

of CSNs. Attempts to remove this inhibitory effect from the CSNs by "preconditioning" medium in which the control cells were cultured proved unsuccessful. However, the activity in the SN generated from the cells cocultured with allogeneic stimulators in conditioned medium was enhanced when compared with the MLC-ASNs coming from cells kept in fresh medium. Since preconditioned medium is simply medium removed from splenocytes cultured for 5 days in BSA medium, it appears that such cells release substances that potentiate the production of proliferative factors by allostimulated splenocytes in MLC. The production of MLC-ASN by spleen cells appears to be prevented by  $\gamma$ -irradiation. However, such irradiation leaves splenocytes capable of activating non-irradiated responder cells. This observation is in agreement with current research on mice (Heeg, Steeg & Wagner, 1988).

Prior *in vivo* allogeneic stimulation of *Xenopus* by skin grafting clearly influenced the ability of splenocytes from that animal to produce mitotic factors. Subsequent *in vitro* stimulation with splenocytes from the same donor haplotype yielded MLC-ASNs that possessed significantly more activity at 24 and 96 hours, than did its autografted control. Thus a further link between allogeneic stimulation and mitotic factor production is established.

Thymocytes from *Xenopus* 8 months of age appear to be functionally immature with respect to the production of (MLC-induced) mitotic factors, compared with splenocytes from animals of the same age. In mice the IL-2 producing cells of the thymus have been studied extensively (Ceredig *et al*, 1983; Pfizenmaier *et al*, 1984; Ceredig *et al*, 1987; Rothenberg,

McGuire & Boyer, 1988; Rothenberg, 1989). These IL-2 producing cells comprise a very small percentage of thymocytes, with only tiny amounts of IL-2 produced by bulk culture of thymocytes, even with mitogen (Ceredig *et al*, 1983). It would be easy to envisage that stimulation of an even smaller sub-population of T cells by alloantigen alone, would be insufficient to produce factors of a detectable amount.

The response of PHA stimulated and non-stimulated thymocytes to splenocyte MLC-SNs differed markedly. It appears that, unlike splenocytes, thymocytes need mitogen pretreatment to make them responsive to the MLC-ASN. This was the first indication of an "IL-2-like" activity in the splenocyte MLC-SNs. Early studies of rats, using partially-purified mitogen-induced SNs were also unsuccessful in stimulating "resting" thymocytes (Nishimura, Kosutsumi & Hashimoto, 1984). However, more recent work has shown that "resting" thymocytes can respond by proliferation when high doses of recombinant IL-2 (rIL-2) are added to the culture (Bellio & Dos Reis, 1989; Thuy *et al*, 1987;). Bellio and Dos Reis additionally demonstrated that the cells that respond to low doses of rIL-2 *in vitro* have been previously activated *in vivo*.

To summarise, this Chapter reveals that mitotic factors are present in ASNs generated from splenic one- and two-way MLCs; allogeneically stimulated thymocytes, on the other hand, failed to produce recordable SN activity. The spleen-derived factors can achieve enhanced proliferation of both splenic lymphoblasts and (putatively unstimulated) splenocytes. In contrast, the factors cause proliferation only of mitogen-treated (not untreated) thymocytes. Prior allografting with

skin, prior to coculture of splenocytes with irradiated splenocyte stimulators of skin donor origin, increases the mitotic activity of the splenocyte-derived, MLC-ASN.

## CHAPTER 3

### THE GENERATION OF STIMULATORY CULTURE SUPERNATANTS USING T CELL MITOGENS

#### 3.1 INTRODUCTION

Mitogens have been used extensively in immunological studies of a wide variety of mammals (Greaves, Bauminger & Janossy, 1972; Rosing & Vaessen, 1979), and also a number of avian (Kline & Sanders, 1980), reptilian (Cuchens & Clem, 1979; Farag & El Ridi, 1986) and amphibian (Wright & Cooper, 1978; Horton *et al*, 1980) species. The plant lectins Con A and PHA polyclonally activate mammalian T cells, whilst LPS from, *E.coli*, is commonly used to stimulate mammalian B cells. These mitogens bind and cross-link specific carbohydrate determinants present on the cell surface of lymphocytes: this in turn induces intracellular changes, including inositol phosphate turnover, elevation of intracellular calcium concentration and progression from G<sub>0</sub> - G<sub>1</sub> of the cell cycle (blastogenesis). Finally the lymphocyte undergoes DNA replication and mitosis.

Mitogen responsiveness has been well documented in *Xenopus*. Studies on the larva have revealed the ontogenic development of thymocyte and splenocyte reactivity to the mitogens Con A and PHA (Williams *et al*, 1983; Rollins-Smith *et al*, 1984). There is considerable evidence that points to *Xenopus* T cells being the target of these two mitogens. For example, extirpation of the *Xenopus* thymus within the first

week of larval life impairs the animal's T cell responses, including the proliferative responses to these classical T cell mitogens (Du Pasquier & Horton, 1976; Donnelly, Manning & Cohen, 1976; Green & Cohen, 1979). Indeed, thymectomy (Tx) throughout most of larval life depletes splenocyte reactivity to PHA (Horton & Sherif, 1977). Also, experiments involving the depletion of IgM-positive leucocytes (B cells) by nylon wool adherence (Blomberg, Bernard & Du Pasquier, 1980) and by panning using an anti-IgM McAb (Bleicher & Cohen, 1981) yielded a population of cells that were particularly responsive to PHA and Con A, but which were depleted of cells responsive to *E.coli* LPS (Bleicher & Cohen, 1981).

This chapter concentrates on the production and assay of proliferative factors secreted by lymphocytes from various *Xenopus* species/strains, following stimulation with PHA or Con A. Since the last chapter revealed disparities between the effects of MLC-generated SNs produced in this laboratory compared with those generated by Watkins & Cohen (1987) - differences relating to target cell types stimulated - it was of interest to observe the potential of T cell-mitogen-generated SNs. Would such factors (like the MLC ASNs studied in Chapter 2) also be able to stimulate lymphoblasts and unstimulated lymphocytes?

A second topic considered in this Chapter is comparison of mitogenic responses in different *Xenopus* species. In particular, no in depth examination has previously been made of the leucocyte responses of *Xenopus tropicalis*. This "tropical" species may be near to the basal



stock from which "polyploid" *Xenopus* species have evolved, since it possesses only 20 chromosomes, unlike many other *Xenopus* (e.g. *X.laevis*, *X.borealis*, LG clones) that have 36 chromosomes. *X.tropicalis* is of potential immunological interest, since recent studies in our laboratory have shown [using ELISA (Turner, unpublished), and FACS (fluorescence-activated cell-sorting) analysis, (Varley, 1990, Ph.D thesis)] that this species lacks the XTLA-1 cell surface marker, found on T lineage lymphocytes of other *Xenopus* species tested. XTLA-1 is a peptide of 120 kD, recognised on the majority of thymocytes and on a major population of peripheral T cells, and is identified by use of the McAb XT-1 (Nagata, 1985, 1986a, 1988). "Absence" of XTLA-1 in *X.tropicalis* raises the question of whether this species is able to display normal T cell functions. Thus, one goal of the work in this Chapter was to probe the response of *X.tropicalis* splenocytes and thymocytes to PHA.

This Chapter also assesses whether mitogen-generated SNS would be able to stimulate lymphocytes removed from early thymectomised (7 day) *Xenopus*. Such Tx animals appear not to possess functional T cells (i.e. they fail to reject or only chronically reject skin allografts (Horton & Manning, 1972; Horton & Horton, 1975; Nagata & Cohen, 1983; Bernard *et al*, 1979), do not respond, or respond minimally to T cell mitogens (Du Pasquier & Horton, 1976; Manning & Collie, 1977; Williams *et al*, 1983); and they cannot produce high affinity antibodies to T-dependent antigens (Du Pasquier & Horton, 1982). In the nude mouse - animals developing with a hypoplastic, non-lymphoid, thymus - leucocytes were capable

of responding, by proliferation, to Con A if exogenous IL-2 was supplied (Gillis *et al*, 1979). Cohen, Watkins & Parsons (1987) similarly demonstrated that in *Xenopus*, splenocytes from individuals thymectomised at 10 days of age, and thus severely immunologically crippled, became responsive to Con A and PHA only after these cells had been cocultured for several days in mitogen-induced ASN with additional PHA.

## 3.2 MATERIALS AND METHODS

### 3.2.1 Animals and thymectomy operation

Thymectomy was carried out on *Xenopus* tadpoles at 5-7 days of age (stages 47-48). Thymectomy was performed following the method of Horton & Manning (1972) using an electromicrocautery technique. A fine tungsten needle was inserted into the thymus, whereupon a voltage was applied which cauterised the thymus. The procedure was carried out under a dissection microscope. Sham-thymectomies were also performed. This involved cauterising a region near the thymus, but leaving the thymus intact. N.B. Sham thymectomised animals were not always available as a control, in which case a sibling, non-operated animal was used. Previous studies have shown that no functional differences have been found between sham-Tx and intact controls (Horton & Manning, 1972).

The animals used in this chapter were *X.borealis*, *X.tropicalis*, LG15, LG5 and LM3 generally of 6 months to 1 year of age, although a few older animals (up to 2 years) were used for splenocyte SN production.

### 3.2.2 Tritiated thymidine incorporation following mitogen stimulation

Assay cells (either splenocytes and/or thymocytes) were adjusted to a concentration of  $1 \times 10^6$  leucocytes/ml in culture medium, (either AL-15:BSA or AL-15:FCS). The type of medium used for each experiment is given in the Results. 100 $\mu$ l aliquots were dispensed into 96-well tissue culture plates (Cell Cult). PHA-M (Flow Labs), PHA-P (Flow Labs), or Con A (Flow Labs) at various concentrations (diluted freshly in medium) were then added in 10 $\mu$ l aliquots. Cells were cultured at  $26 \pm 1^\circ\text{C}$  (in 5%  $\text{CO}_2$ ) for various lengths of time. Each well was pulsed with 1 $\mu$ Ci tritiated thymidine (Amersham, Sp.Act. = 5Ci/mmol) 24 hours before harvesting and scintillation counting.

### 3.2.3 Generation of SNs following PHA-M or Con A stimulation

Splenocytes from 1-2 year old *Xenopus* were cultured with mitogen in AL-15:BSA. Cell suspensions were adjusted to  $4-5 \times 10^6$  leucocytes/ml. 1ml aliquots were dispensed into

24-well flat-based plates (Cell Cult, Sterilin). To generate PHA-M SNs, mitogen was added to give a final "in well" concentration of 1/500. To generate Con A SNs, Con A was added to give an "in well" concentration of 1µg/ml. Control cultures contained splenocytes in medium alone. Cells were cultured for 24 hours at 26 ± 1°C and in 5% CO<sub>2</sub>. At this time, plates were centrifuged at 300g for 10 minutes at 4°C, and the culture SN was then removed by pipetting.

Some PHA-M SNs, along with their controls, were then treated <sup>with</sup> chicken red blood cell (CRBC; see below) to remove residual PHA. Con A SNs and controls were treated with alpha-methyl-d-mannoside (Sigma) to neutralise Con A (see below). All SNs were finally filtered through 0.2µm filters and frozen in cryovials (Nunc).

Thymocyte SNs were generated in a similar manner, although animals were just 8-10 months of age, since thymocyte numbers decrease in older animals.

#### 3.2.4 Removal of PHA using chicken red blood cells

Removal of PHA-M was performed following a modification of the procedure used by Watkins & Cohen (1987).

Chicken red blood cells (CRBC; Tissue Culture Services) were washed twice with Alsever's solution (Flow Labs). ASN or CSN was incubated with one tenth the packed volume of CRBC for 1.5 hours on ice. The CRBC were then removed by centrifugation at 300g for 10 mins at 4°C. The SN was collected, filtered (0.2µm) and frozen.

In an additional experiment, a range of PHA-M solutions was made in AL-15:BSA. These solutions also underwent the CRBC adsorption. Residual mitogen activity of the treated PHA-solutions was compared with non-CRBC-passed solutions by assay on fresh splenocytes.

### 3.2.5 Removal of Con A by treatment with alpha-methyl-d-mannoside ( $\alpha$ mm)

A 1 $\mu$ g/ml Con A solution in AL-15:BSA was treated with its inhibitor,  $\alpha$ mm, at concentrations of 0.01, 0.02, 0.05 and 0.1M, to find the required dose to inactivate the Con A. Residual Con A activity was assayed by testing the ability of the solutions to stimulate fresh splenocytes. Untreated Con A solutions were used as controls. The dose selected for use with the SNs was 0.1M.

### 3.2.6 Assay cells

The cells that had been used for PHA-induced ASN generation were cultured for a further 4-8 days in either AL-15:BSA or AL-15:FCS medium (details for each experiment are given in the Results). Blast cells were then separated by Ficoll centrifugation, (see section 2.2.7), unless stated otherwise.

Cells that were cultured for CSN-generation (i.e. no PHA added) were used as "unstimulated" assay cells.

### 3.2.7 Proliferation assay for SN activity

SN assays were performed as detailed in 2.2.7.

## 3.3 RESULTS

### 3.3.1 Mitogen response of *X. borealis* and *X. tropicalis* splenocytes and thymocytes to PHA

*X.borealis* (Xb) splenocytes showed maximal tritiated thymidine incorporation at a dose of 1/500 PHA-M, when harvested at 3, 5 and 7 days of culture. The highest tritiated thymidine counts were observed on day 5 of culture (see Fig. 3.1).

Xb thymocytes also responded best at a dose of 1/500 PHA-M, with the highest counts recorded on day 3 of culture (Fig. 3.2).

1/500 PHA-M is the concentration routinely used in the laboratory for optimally stimulating cells from outbred *X.laevis* and LG clones (data not shown).

Studies on *X.tropicalis* thymocytes (comparing FCS- and BSA-supplemented media) showed that when culture times of 2, 3 and 4 days were performed, harvesting at 3 days yielded the best level of stimulation (see Fig. 3.3). *X.tropicalis* thymocytes in AL-15:FCS(1%) showed maximal tritiated thymidine incorporation at a dose of 1/2500 PHA-M. Cells from the same thymuses cultured in AL-15:BSA medium responded well to PHA dilutions from 1/2500 to 1/10 000.

The response of *X.tropicalis* splenocytes to PHA-M was not assessed; instead PHA-P (highly purified PHA) was tested. This T cell mitogen yielded an optimum response on day 3, with a dilution of 0.1µg/ml PHA-P (Fig.3.4).

In summary, *X.tropicalis* thymocytes and splenocytes responded well to PHA. This response was greater in AL-15:FCS(1%) medium than in AL-15:BSA. *X.tropicalis* splenocytes yielded respectable PHA-induced SIs which compared well with those seen with other *Xenopus* examined in this laboratory with PHA-P. *X.tropicalis* thymocytes also showed significant stimulation (SI > 3.0 at optimum doses) when cocultured with PHA.

### 3.3.3 Studies on PHA-induced culture supernatants

#### 3.3.3.1 Effect of CRBC treatment on PHA-M solutions

CRBC treatment dramatically impaired the ability of PHA solutions to stimulate tritiated thymidine incorporation by LM3 splenocytes (Fig. 3.5). Some residual activity (e.g. SI = 4.5, with 1/500 adsorbed PHA) of CRBC-passed PHA was noted, however, since tritiated thymidine counts cultured in such conditions, revealed a small, but significant, increase in proliferation compared with medium controls (see also data in 3.3.3.3 below).

3.3.3.2 Promotion of mitosis by PHA-M-induced supernatants:  
comparison of splenocytes and splenic  
lymphoblasts as assay cells

The PHA-M ASNs (produced by LM3) were stimulatory for splenic lymphoblasts from *X.laevis*. Results of two SNs are shown in Table 3.1. However, CRBC treatment (of ASN 2) removed some activity from the ASN, reducing the SI from 12.2 achieved by use of the non-CRBC treated SN, to 5.7. The same ASNs also appeared to promote tritiated thymidine incorporation of *X.laevis* splenocytes - i.e. cells pre-cultured for 8 days in FCS medium in the absence of PHA, though a CSN was not available for this part of the experiment to confirm this point (Table 3.1).

3.3.3.3 Promotion of mitosis by PHA-M-induced supernatants:  
comparison of splenocytes and thymocytes as  
assay cells

Table 3.2 reveals that PHA-M solutions of 1/500 and 1/5000 (1:2000) and 1:20 000 final concentration in the well) caused considerable proliferation of LM3 splenocytes. The equivalent solutions that had been CRBC-passed showed minimal ability to stimulate. The incorporation of tritiated thymidine by splenocytes treated with CRBC-adsorbed ASNs was significantly greater than that achieved when cells were cultured in CRBC-adsorbed PHA solutions (containing the same maximum amount of PHA) thereby revealing activity generated by factors in the SN other than the mitogen itself.

Thymocytes revealed a lower level response (max SI = 1.7)



to PHA-ASNs. Again, no CSNs were available for this experiment.

#### 3.3.3.4 Attempt to generate ASN from thymocytes

Thymocytes taken from 8-10 month old animals (LG5-wild) and stimulated with PHA-P produced a SN that induced a small but significant degree of thymidine incorporation when tested on assay splenocytes (Fig. 3.6).

#### 3.3.4 Studies on Con A-stimulated mitogenesis

##### 3.3.4.1 Mitogen response of control splenocytes to Con A

Optimum stimulation of J and LG5 splenocytes was observed at a concentration of  $1\mu\text{g/ml}$  Con A on day 5 of culture (Fig. 3.7). For J splenocytes the Con A response was very dose dependent, with concentrations either side of  $1\mu\text{g/ml}$  (i.e.  $10\mu\text{g/ml}$  and  $0.5\mu\text{g/ml}$ ) virtually being unable to induce extensive tritiated thymidine incorporation. LG5 splenocytes responded nearly as well to Con A concentrations of  $0.5\mu\text{g/ml}$  and  $1\mu\text{g/ml}$ .

##### 3.3.4.2 Effect of thymectomy on Con A stimulation

7 day Tx animals responded very poorly to Con A, though thymidine incorporation over background counts was observed. Fig. 3.8 shows SIs for control and Tx *X.laevis*.

### 3.3.5 Studies on Con A-induced culture supernatants

#### 3.3.5.1 Effect of alpha-methyl-d-mannoside on removal of

##### Con A

A dose of 0.1M  $\alpha$ mm in a 1 $\mu$ g/ml Con A solution completely abrogated the splenocyte response to this mitogen (Table 3.3). With lower concentrations of  $\alpha$ mm, mitogenic activity was still present in the Con A solutions.

#### 3.3.5.2 Comparison of PHA-P and Con A-induced SNs to stimulate splenocytes from thymectomised and control

##### *X.laevis*

PHA-P ASN (CRBC-passed) and Con A ASN ( $\alpha$ mm-treated) both enhanced proliferation of splenocytes removed from control and thymectomised animals. Splenocytes from thymectomised animals responded particularly well to these ASNs (Table 3.4)

FIG. 3.1

*X.borealis* splenocytes were dispensed ( $1 \times 10^5$  leucocytes/well) into 96-well V-based plates in AL-15:FCS(1%).

PHA-M was added to produce "in well" dilutions of 1/100, 1/500, 1/1000 and 1/5000. Cultures were set up in triplicate. Each well was pulsed with  $1\mu\text{Ci}$  [ $^3\text{H}$ ]TdR 24 hours before harvesting. Splenocytes were cultured for 3, 5 and 7 days.

FIG. 3.1 RESPONSE OF X. BOREALIS SPLENCYTES TO PHA-M

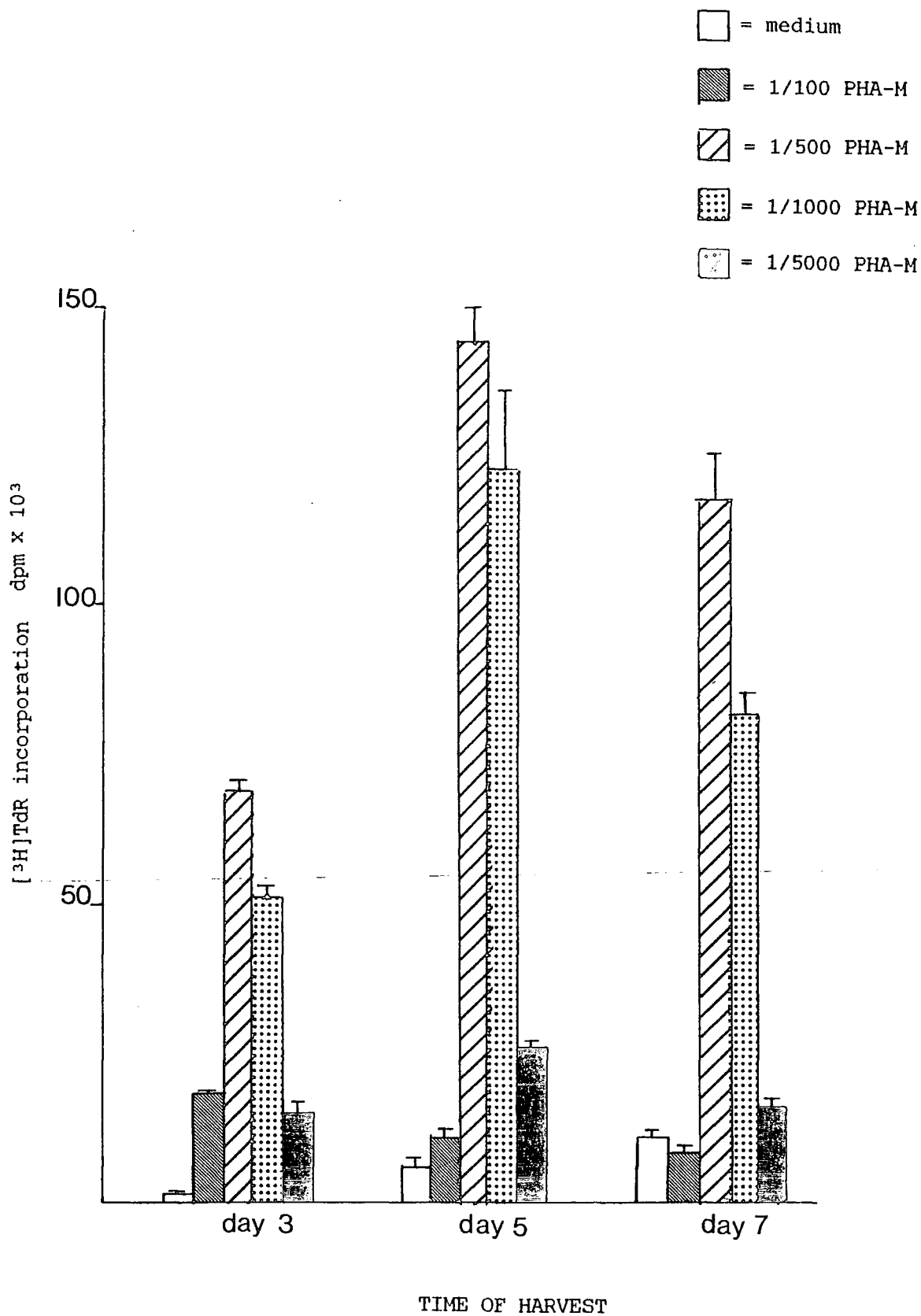

FIG. 3.2

*X.borealis* thymocytes were dispensed ( $1 \times 10^5$  leucocytes/well) into 96-well V-based plates in AL-15:FCS(1%).

PHA-M was added to produce "in well" dilutions of 1/100, 1/500, 1/1000 and 1/5000. Cultures were set up in triplicate. Each well was pulsed with  $1\mu\text{Ci}$  [ $^3\text{H}$ ]TdR 24 hours before harvesting. Thymocytes were cultured for 3, 5 and 7 days.

FIG. 3.2 PROLIFERATIVE RESPONSES OF *X. BOREALIS* THYMOCYTES TO PHA-M

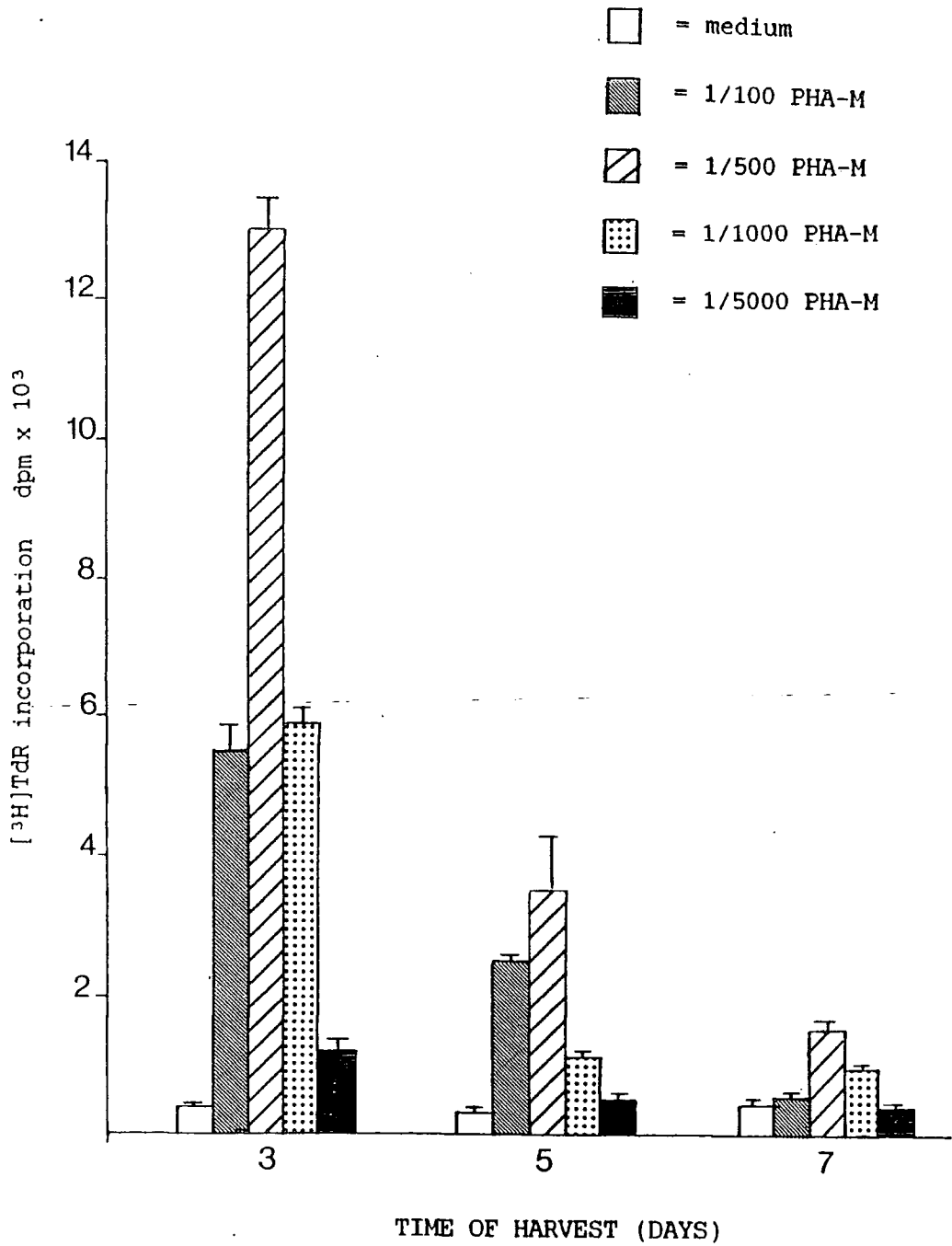

FIG. 3.3

*X. tropicalis* thymocytes were dispensed ( $1 \times 10^5$  leucocytes/well) into 96-well V-based plates. Thymocytes were cultured in AL-15:FCS(1%) or AL-15:BSA.

PHA-M was added to produce "in well" dilutions of 1/1000, 1/2500, 1/7500 and 1/10 000. Cultures were set up in triplicate. Each well was pulsed with  $1\mu\text{Ci}$  [ $^3\text{H}$ ]TdR 24 hours before harvesting. Thymocytes were cultured for 2, 3, and 4 days.

FIG. 3.3 RESPONSE OF *X. TROPICALIS* THYMOCYTES TO PHA-M:

COMPARISON OF MEDIUM SUPPLEMENTED WITH FCS OR BSA

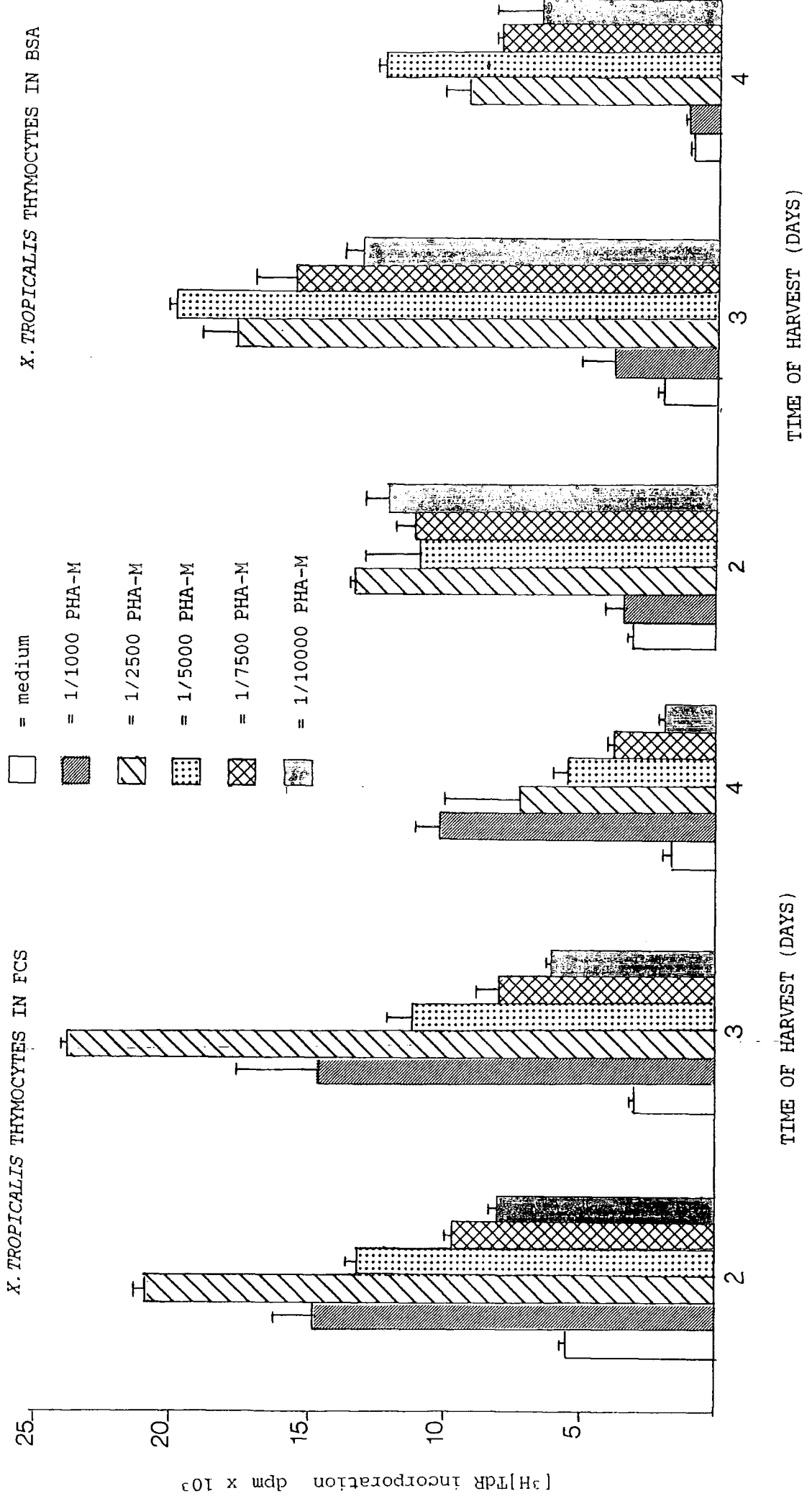



FIG. 3.4

*X. tropicalis* splenocytes were dispensed ( $1 \times 10^5$  leucocytes/well) into 96-well V-based plates. Splenocytes were cultured in AL-15:FCS(1%) or AL-15:BSA.

PHA-P was added to produce "in well" dilutions of 5.0, 1.0, 0.1, and  $0.01 \mu\text{g/ml}$ . Cultures were set up in triplicate. After 72 hours (3 days) or 96 hours (4 days) in culture each well was pulsed with  $1 \mu\text{Ci}$  [ $^3\text{H}$ ]TdR and harvested 24 hours later.

FIG. 3.4 RESPONSES OF *X. TROPICALIS* SPLENCYTES TO PHA-P:

COMPARISON OF MEDIUM SUPPLEMENTED WITH FCS OR BSA

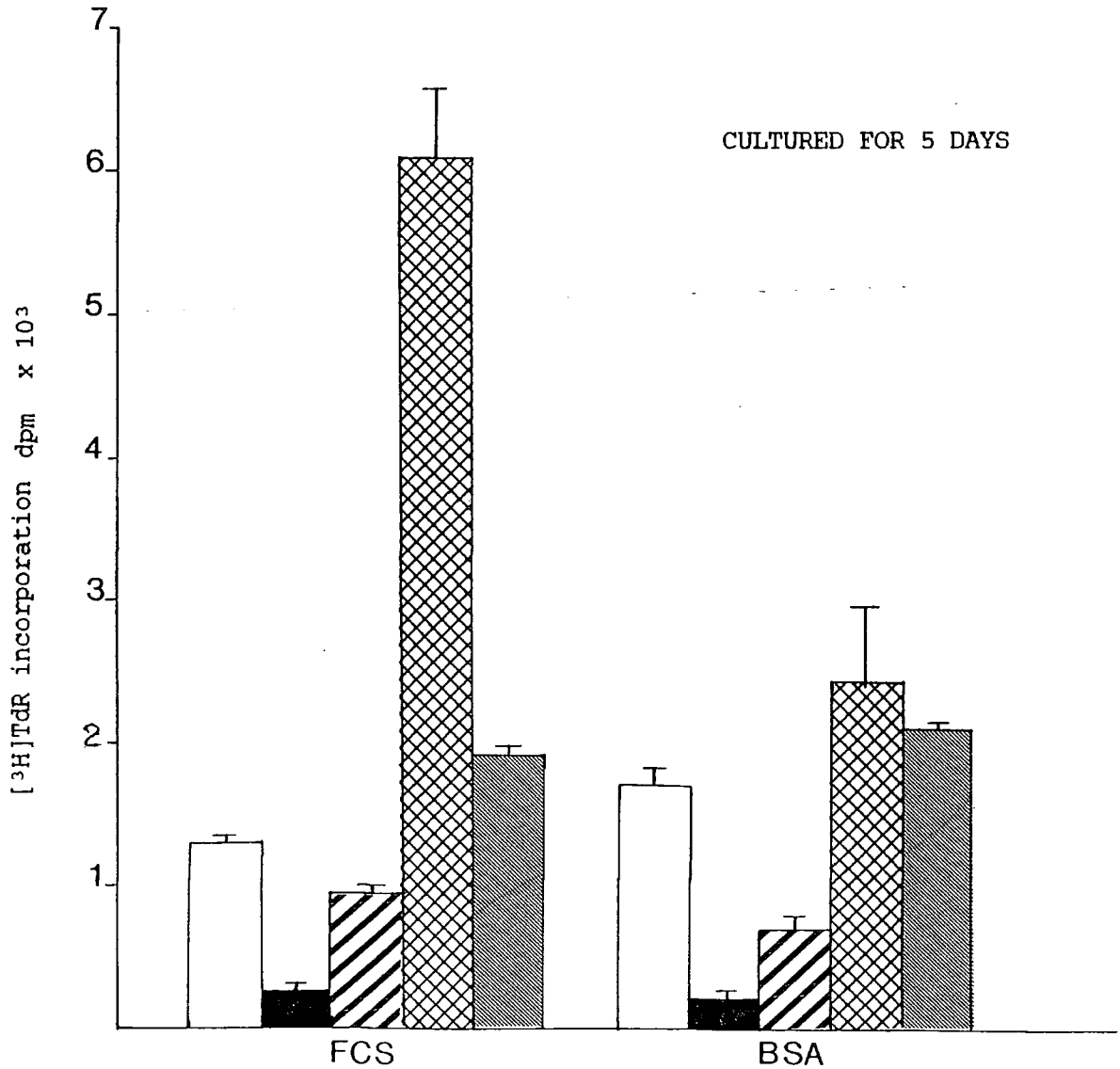
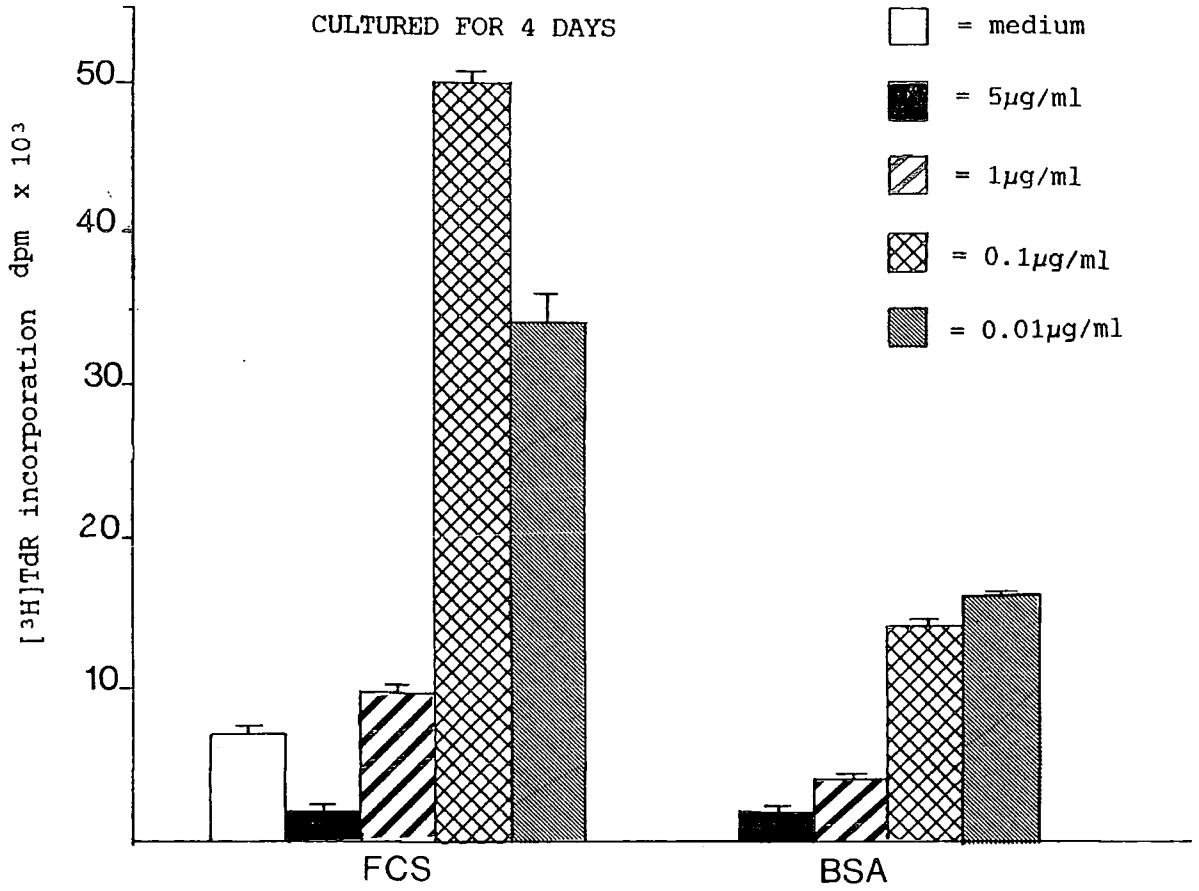

FIG. 3.5

LM3 splenocytes were dispensed ( $1 \times 10^5$  leucocytes/well) in  $100 \mu\text{l}$  volumes in 96-well flat-based plates in AL-15:BSA. PHA-M dilutions of 1/100, 1/500 and 1/2500 were made up in AL-15:BSA. These same concentrations, that had been previously adsorbed with CRBC, were also prepared. The final "in well" concentration of adsorbed or unadsorbed PHA was 1/400, 1/2000 and 1/10,000, since  $50 \mu\text{l}$  was added to  $100 \mu\text{l}$  cells plus  $50 \mu\text{l}$  medium (to mimic the subsequent assay procedure with SNs). Cultures were set up in triplicate. After 48 hours in culture, each well was pulsed with  $1 \mu\text{Ci}$  [ $^3\text{H}$ ]TdR and harvested 24 hours later.

FIG. 3.5 CRBC-ADSORPTION REMOVES MITOGENIC PROPERTIES FROM PHA-M

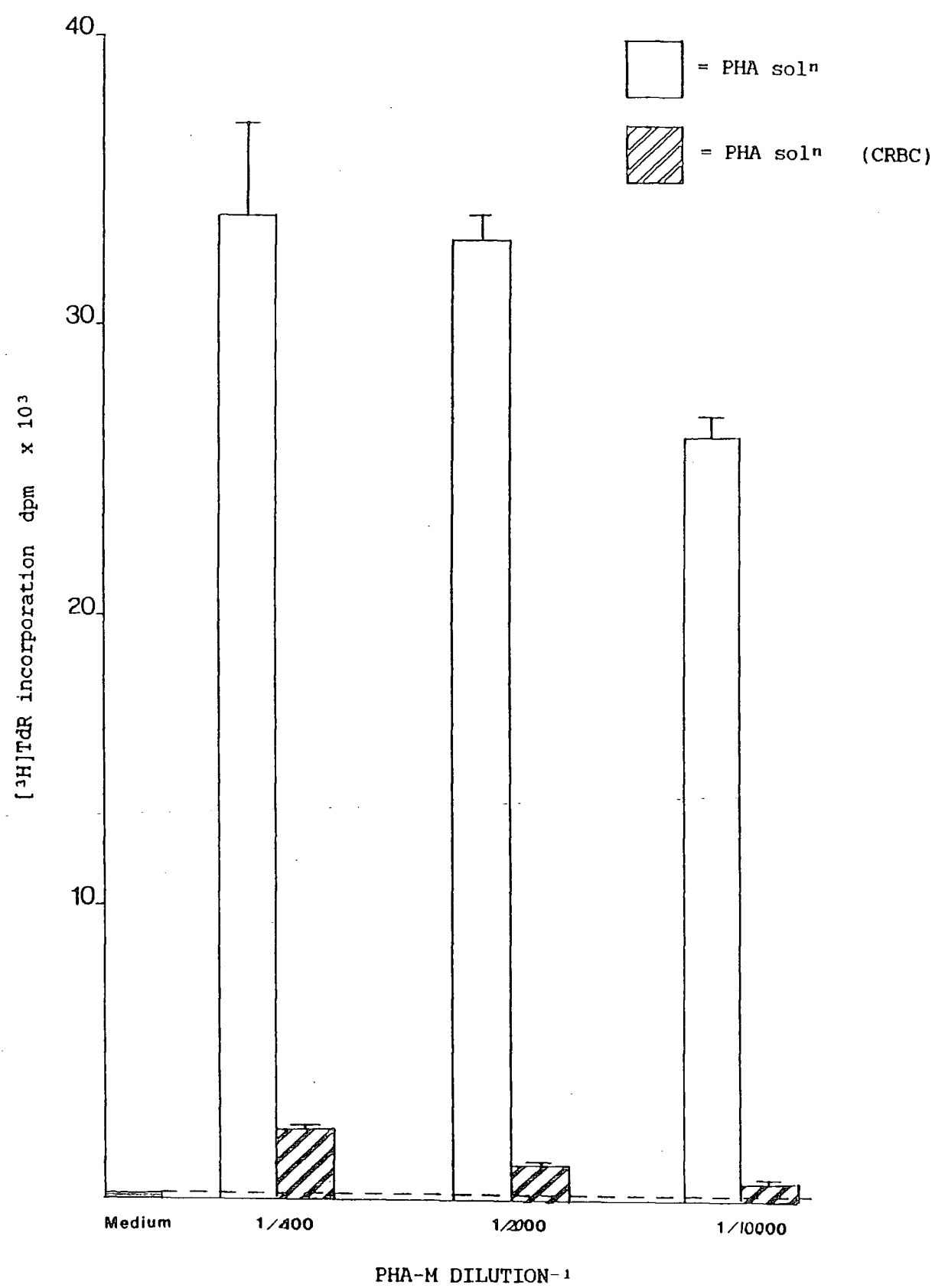

FIG. 3.6

PHA-P-ASNs from LG15-wild thymocytes were generated by culture of  $4 \times 10^6$  leucocytes/ml with  $0.2\mu\text{g}$  PHA-P in AL-15:BSA. PHA-P-SNs were collected 48 hours after initiation of culture and CRBC-treated. CSNs were also produced from LG15-wild thymocytes (CRBC-treated). Additionally,  $0.2\mu\text{g/ml}$  PHA-P solutions were CRBC-treated.

"Fresh" assay cells (LG15-wild splenocytes:  $1 \times 10^5$  leucocytes/well) were dispensed into 96-well flat-based plates in AL-15:FCS(1%). PHA-P-ASN, CSN or  $0.2\mu\text{g/ml}$  PHA-P were added to give a final "in well" concentration of 25% in a total volume of  $200\mu\text{l}$ . Cultures were set up in triplicate. After 48 hours of culture, each well was pulsed with  $1\mu\text{Ci}$  [ $^3\text{H}$ ]TdR and harvested 24 hours later.

The dotted line represents the dpm of assay cells cultured in medium alone.

SNs 1, 2, 3, 4 and 5 represent five different PHA-P-ASNs, along with their controls.

FIG. 3.6 EFFECT OF THYMOCYTE PHA-P-SNs ON LG15/WILD SPLENOCYTES

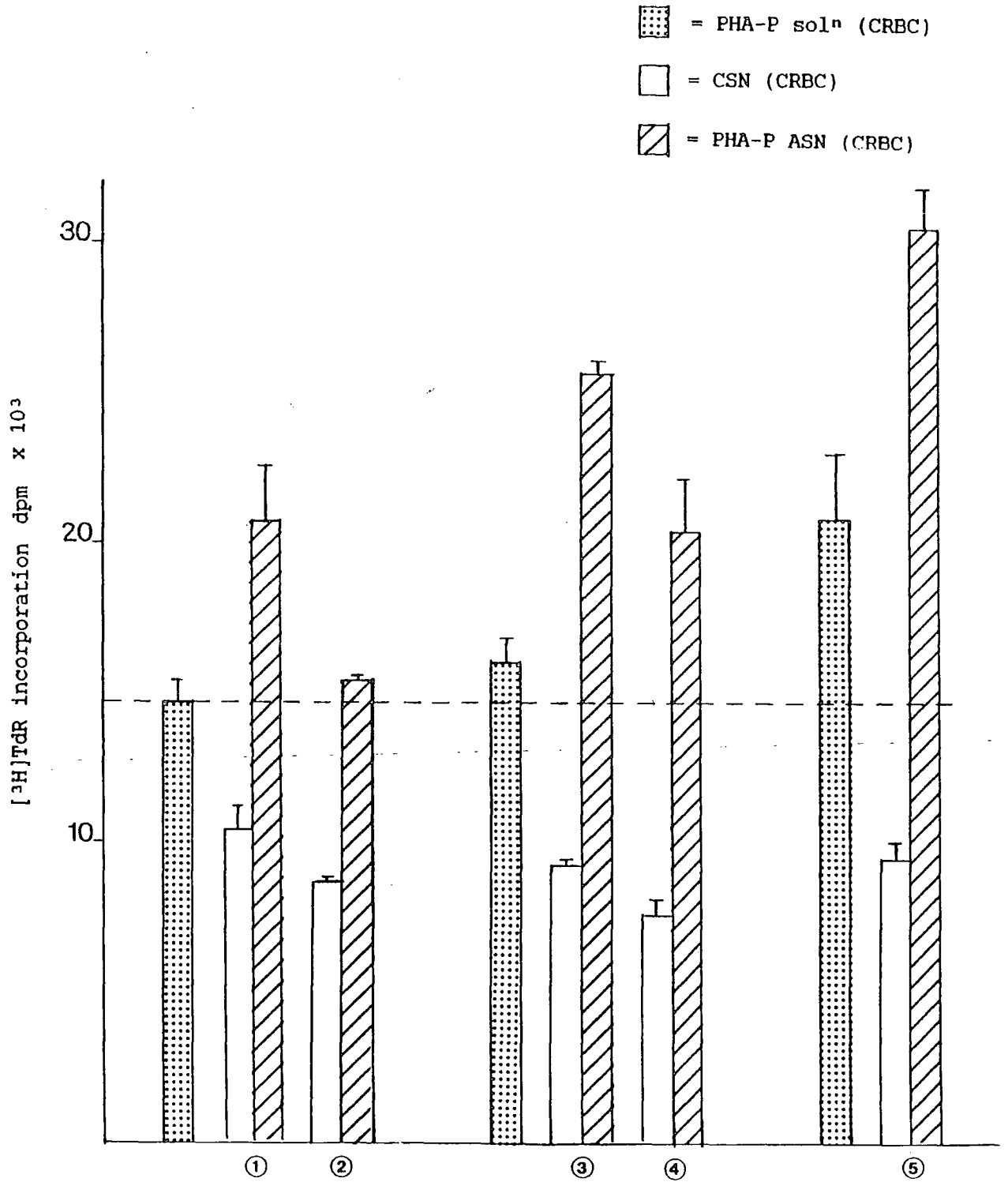

FIG. 3.7

A range of Con A concentrations was made to produce "in well" concentrations of 100, 10, 1.0, 0.5 and 0.1 $\mu$ g/ml, these were assayed on J and LG5 splenocytes, which had been dispensed ( $1 \times 10^5$  leucocytes/well) into 96-well flat-based plates in AL-15:FCS(1%). Cultures were set up in triplicate. Each well was pulsed with 1 $\mu$ Ci [ $^3$ H]TdR 24 hours before harvesting. Splenocytes were harvested at 72hr (3 days) and 120hr (5 days).

FIG. 3.7 MITOGEN RESPONSES OF SPLENCYTES TO CON A

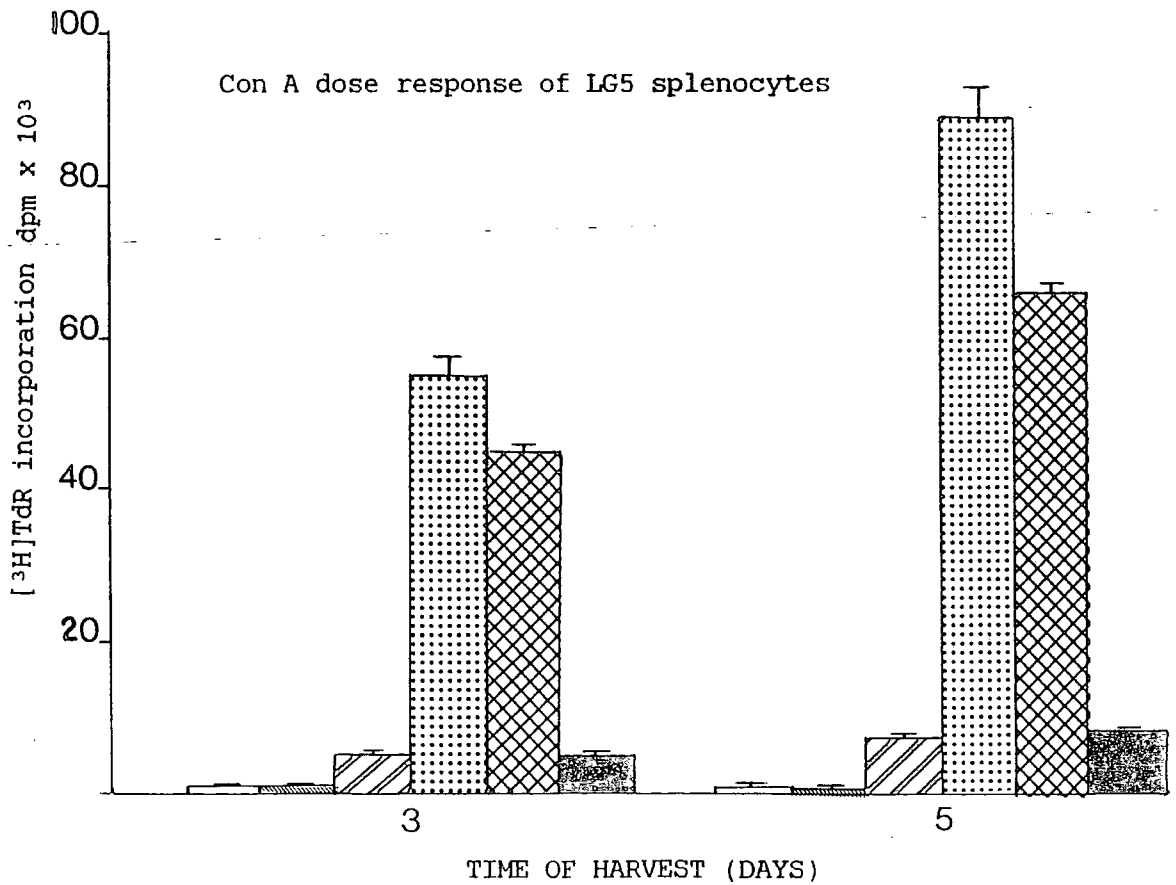
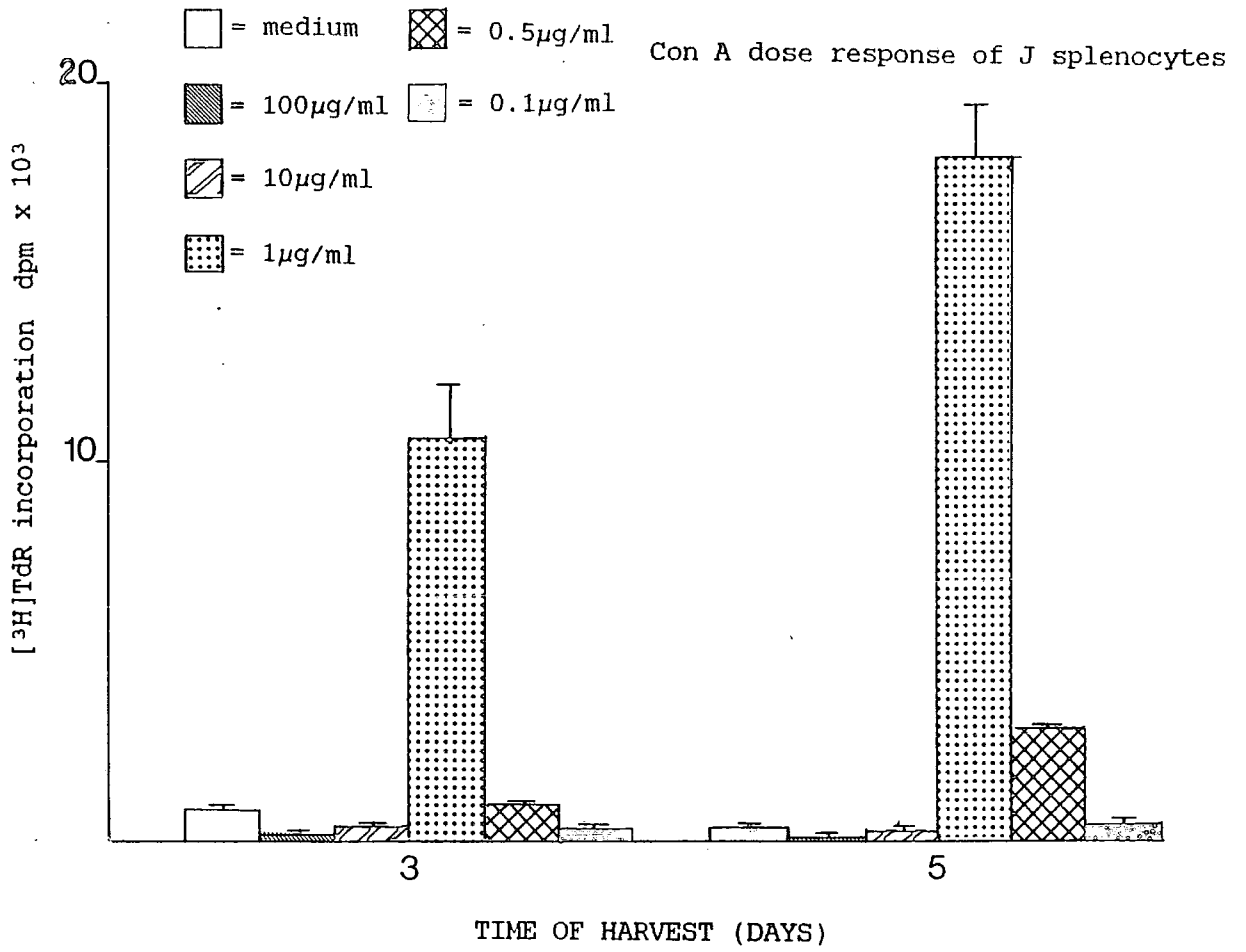



FIG. 3.8

A range of Con A concentrations was made as shown. These were assayed on *X.laevis* splenocytes from 6 month old control and 7 day Tx animals, which had been dispensed ( $1 \times 10^5$  leucocytes/well) into 96-well flat-based plates in AL-15:FCS(1%).. Cultures were set up in triplicate. After 48 hours in of culture, each well was pulsed with  $1\mu\text{Ci}$  [ $^3\text{H}$ ]TdR and harvested 24 hours later.

All data is shown as stimulation indices [SIs].

$$\text{SI} = \frac{\text{cultures + Con A (dpm)}}{\text{cultures + medium (dpm)}}$$

FIG. 3.8 STIMULATION INDICES OF SPLENCYTES FROM CONTROL

AND 7-DAY THYMECTOMISED *X. LAEVIS*

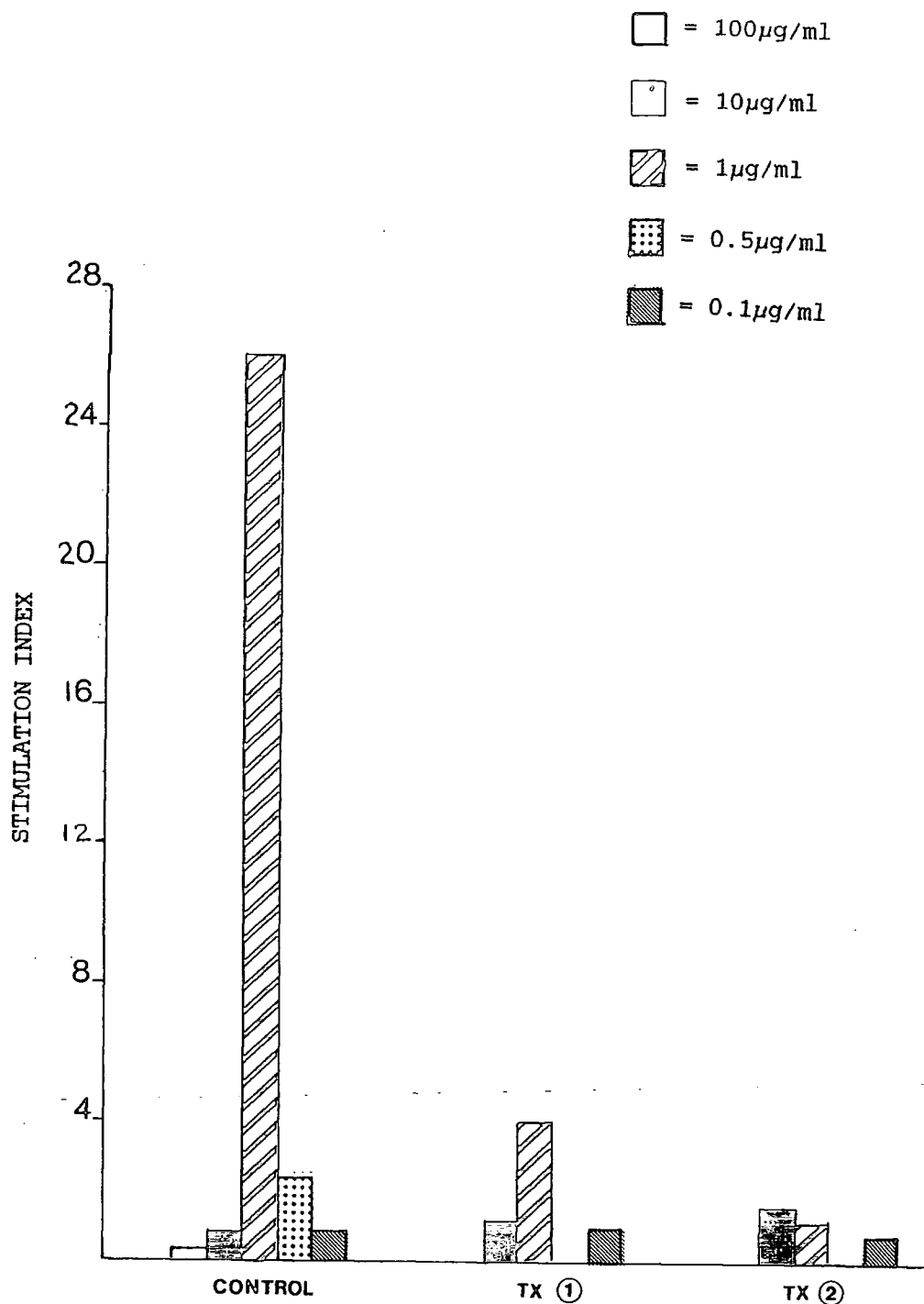

TABLE 3.1

*X. laevis* splenocytes ( $4 \times 10^6$  leucocytes/ml) were precultured with medium (AL-15:FCS; to provide "unstimulated" cells) or 1/500 PHA-M (to generate blasts) for 8 days. Cells were then centrifuged over Ficoll and those collected from the Ficoll surface were used as assay cells.

$1 \times 10^5$  assay leucocytes were dispensed in 100 $\mu$ l aliquots into 96-well flat-based plates in AL-15:FCS(1%). Control or PHA-ASNs were either used directly or after CRBC-adsorption, to give a final "in well" concentration of 25% in a total volume of 200 $\mu$ l. Cultures were set up in triplicate.

After 48 hours of culture, each well was pulsed with 1 $\mu$ Ci [ $^3$ H]TdR and harvested 24 hours later.

TABLE 3.1 ABILITY OF PHA-M SNS TO STIMULATE (8 DAY PRECULTURED) SPLENIC  
LYMPHOBLASTS AND SPLENOCYTES

| type of assay cells | assay cells cultured in: |  |  |                   | mean dpm $\pm$ sem<br>[SI] |
|---------------------|--------------------------|--|--|-------------------|----------------------------|
|                     | medium                   | CSN 1 (CRBC)<br>ASN 1 (CRBC)               | CSN 2<br>ASN 2 (CRBC)                              | ASN 2 (CRBC) [SI] |                            |
| Blasts              | 3060 $\pm$ 113           | 3063 $\pm$ 163<br>13552 $\pm$ 183<br>[4.4] | 1725 $\pm$ 39<br>21081 $\pm$ 644<br>9947 $\pm$ 486 | [12.2]<br>[5.7]   |                            |
| Splenocytes         | 134 $\pm$ 9              | n.d.<br>3012 $\pm$ 88                      | n.d.<br>4290 $\pm$ 264<br>1220 $\pm$ 77            |                   |                            |

(CRBC) = SNS that have been CRBC treated

TABLE 3.2

Assay cells - LM3 splenocytes and thymocytes -(1 x 10<sup>5</sup> leucocytes/well) were dispensed into 96-well flat-based plates in AL-15:FCS(1%). PHA-M-SNs [generated by culture of LM3 splenocytes (4 x 10<sup>6</sup> leucocytes/ml) with 1/500 PHA-M in AL-15:BSA, then CRBC-treated], were added to assay cells to give a final "in well" concentration of 25% in a total volume of 200 $\mu$ l. PHA-M or PHA-M (CRBC-treated) solutions were added to the assay cells. Cultures were set up in triplicate.

After 48 hours of culture, each well was pulsed with 1 $\mu$ Ci [<sup>3</sup>H]TdR and harvested 24 hours later.

TABLE 3.2 ABILITY OF PHA-M-INDUCED SNS TO STIMULATE "FRESH" THYMOCYTES AND SPLENOCYTES

| type of assay cell | assay cells cultured in: |                            |                              |                         | mean dpm $\pm$ sem [SI]  |                          |                          |
|--------------------|--------------------------|----------------------------|------------------------------|-------------------------|--------------------------|--------------------------|--------------------------|
|                    | medium                   | PHA-M*<br>PHA-M*<br>(CRBC) | PHA-M**<br>PHA-M**<br>(CRBC) | ASN 1<br>(CRBC)         |                          | ASN 2<br>(CRBC)          | ASN 3<br>(CRBC)          |
| splenocytes        | 205 $\pm$ 205            | 147714 $\pm$ 11347         | 84135 $\pm$ 5037             | 13907 $\pm$ 25<br>[2.5] | 15260 $\pm$ 166<br>[2.7] | 11296 $\pm$ 209<br>[2.0] | 12962 $\pm$ 323<br>[2.3] |
| thymocytes         | 769 $\pm$ 20             | 7209 $\pm$ 691             | n.d.                         | 1910 $\pm$ 84<br>[1.5]  | 2120 $\pm$ 76<br>[1.7]   | n.d.                     | n.d.                     |

\* = 1/2000 PHA-M dilution  
 \*\* = 1/20000 PHA-M dilution  
 CRBC = Solutions/ASNs CRBC-treated ASN 1 & 2 = LM3  
 ASN 3 & 4 = LG15

SI =  $\frac{\text{expt. cultures (ASN)}}{\text{PHA-M* (CRBC) cultures}}$  (dpm)  
 N.B. Max. amount of PHA in untreated ASNs = 1:500, i.e. 1:2000 when diluted 1/4 on assay cells.

TABLE 3.3

In order to find the inhibiting concentration of  $\alpha$ mm, 1 $\mu$ g/ml Con A solution was made up in AL-15:BSA and  $\alpha$ mm was added at concentrations of 0.0, 0.01, 0.02, 0.05 and 0.1 M. The solutions were then assayed for any residual mitogenic activity.

Assay cells (J splenocytes:  $1 \times 10^5$  leucocytes/well) were dispensed into 96-well flat-based plates in AL-15:FCS(1%). The Con A solutions were added to give a final "in well" concentration of 25% (i.e. diluted 4-fold to mimic the SN experiments) in a total volume of 200 $\mu$ l. Cultures were set up in triplicate.

After 48 hours of culture, each well was pulsed with 1 $\mu$ Ci [ $^3$ H]TdR and harvested 24 hours later.

TABLE 3.3 EFFECT OF ALPHA METHYL-D MANNOSIDE ON CON A RESPONSIVENESS OF  
J SPLENOCYTES

| medium       | Con A<br>(1 $\mu$ g/ml)* | Con A (1 $\mu$ g/ml) treated with $\alpha$ mm (M): |                          |
|--------------|--------------------------|--|--------------------------|
|              |                          | 0.01   | 0.02                     |
|              |                          |  | 0.05                     |
|              |                          |  | 0.1                      |
|              |                          | mean dpm $\pm$ sem<br>[SI]                         |                          |
| 115 $\pm$ 23 | 3385 $\pm$ 879<br>[29.0] | 11967 $\pm$ 1092<br>[104.0]                        | 6441 $\pm$ 596<br>[56.0] |
|              |                          | 549 $\pm$ 50<br>[4.7]                              | 138 $\pm$ 43<br>[1.2]    |

\* Final "in well" concentration = 0.25 $\mu$ g/ml, after dilution 1/4.



TABLE 3.4

Con A-SNs (LM3-derived) were treated with 0.1M  $\alpha$ mm and assayed, along with PHA-P-SNs (CRBC treated), for their proliferative activity on "fresh" splenocytes from control and Tx *X.laevis*.

Assay cells (*X.laevis* splenocytes:  $1 \times 10^5$  leucocytes/well) were dispensed into 96-well flat-based plates in AL-15:BSA). The Con A-SNs or PHA-P-SNs were added to give a final "in well" concentration of 25% SN in a total volume of 200 $\mu$ l. Cultures were set up in triplicate.

After 48 hours of culture, each well was pulsed with 1 $\mu$ Ci [ $^3$ H]TdR and harvested 24 hours later.

$$\text{SI} = \frac{\text{cultures + ASN (dpm)}}{\text{cultures + CSN (dpm)}}$$

TABLE 3.4 EFFECT OF ("MITOGEN-FREE") PHA-P-SNS AND CON A-SNS ON  
SPLENOCYTES FROM CONTROL AND TX X.LAEVIS

| animal  | assay cells cultured with: |  |  |  |
|---------|----------------------------|--|--|--|
|         | medium                     | PHA-P CSN<br>PHA-P ASN                   | CON A CSN<br>CON A ASN                     |  |
|         |                            | mean dpm $\pm$ sem<br>[SI]               |  |  |
| control | 135 $\pm$ 29               | 399 $\pm$ 44<br>1683 $\pm$ 176<br>[4.2]  | 711 $\pm$ 4<br>1537 $\pm$ 112<br>[2.2]     |  |
| Tx 1    | 770 $\pm$ 53               | 707 $\pm$ 90<br>7957 $\pm$ 867<br>[11.0] | 596 $\pm$ 148<br>6649 $\pm$ 2175<br>[11.0] |  |
| Tx 2    | 171 $\pm$ 47               | 467 $\pm$ 113<br>2506 $\pm$ 314<br>[5.4] | 109 $\pm$ 34<br>1055 $\pm$ 334<br>[9.7]    |  |

### 3.4 DISCUSSION

Mitogen-derived ASNs from the splenocytes of XTLA-1 positive *Xenopus* (*X.borealis*, *X.laevis*, LM and LG clones) routinely produced proliferation, as measured by tritiated thymidine incorporation, of "unstimulated" splenocytes (assayed when taken directly from the animal, or precultured without mitogen), as well as mitogen-treated lymphoblasts. Although residual PHA may be present in CRBC-passed ASNs, it is insufficient to cause the proliferative effects of the PHA-ASNs. This ability of PHA-ASNs to stimulate previously "unstimulated" splenocytes was also demonstrated by the MLC-ASNs, as discussed in Chapter 2, and suggests that these ASNs can target cells that may include a variety of cell types, only one of which is a T cell activated blast. It is probable that a variety lymphokines are present in our crude *Xenopus* SNs, since a variety of soluble mediators have been described in culture SNs (mitogen and alloantigen derived) in mammals (Hagiwara et al, 1987; Cherwinski et al, 1987).

The ability of both MLC and PHA-derived SNs to cause proliferation in the "unstimulated" splenocyte as well as splenoblast cell populations is in contrast with published results (Watkins and Cohen, 1987). The PHA and MLC-SNs generated by Watkins and Cohen only stimulated mitogen treated splenoblasts, and were ineffective at driving proliferation of unstimulated splenocytes. [N.B. The spleen cells treated with mitogen, to produce blasts, are different from the "unstimulated" splenocytes. This is

demonstrated by the refractory effect (in terms of proliferation) of further mitogen treatment on blasts; this is discussed more fully in Chapter 4.]

Cohen, Watkins and Parsons (1987) performed ontogenic studies on thymocyte SN production, but were unable to show that thymocytes produced mitotic factors at the stages they tested (stages 52-53, 55 and at 18 months of age). However, their study did not include the responses of 8 month old animals. Previous work has shown that *Xenopus* thymocytes are most responsive to PHA from animals of this age (Williams *et al*, 1983). Thus, it seemed pertinent to examine thymocyte SN production in animals of this age. These studies showed that PHA-P-stimulated thymocytes from 8 month old animals were capable of producing a SN that induced some degree of mitosis when tested on splenocyte assay cells. As has been shown to be the case with mammals (Ceredig *et al*, 1983, 1987; Pfizenmaier *et al*, 1984) activity from *Xenopus* thymocyte bulk cultures was small, but detectable. These authors propose that this is because only a small subset of thymocytes are producing the necessary T cell growth factor. The IL-2 producing cells have been shown to be the functionally-mature thymocytes (Rothenberg *et al*, 1988).

To date there has been no investigation of the mitogen responses of the XT-1 negative species *Xenopus tropicalis*. The results presented here show that with respect to PHA stimulation, both *X.tropicalis* thymocytes and splenocytes can respond. As is the case in other *Xenopus* (e.g. Williams *et al*, 1983), *X.tropicalis* splenocytes showed better proliferative responses to PHA than did thymocytes.

This may well reflect that there are a higher proportion of functionally mature T cells in the spleen than in the thymus. Alternatively, the poorer proliferation by thymocytes could be due to a lack of the relevant cytokines in the thymus needed to achieve cell proliferation - e.g. IL-1/IL-2, see Watkins & Cohen, 1987)

Attempts to produce mitotically active factors from PHA-M treated *X.tropicalis* splenocytes were unsuccessful (data not presented). However, this may reflect inexperience in handling *X.tropicalis* leucocytes rather than proof that this species does not produce lymphokines. Indeed, many more experiments varying culture media, density of cells (particularly since *X.tropicalis* leucocytes are very much smaller than for other *Xenopus*), and length of cell culture time are required to fully investigate the best *in vitro* conditions for ASN generation in *X.tropicalis*.

Con A was also used in this Chapter to explore mitogen induced SN activity. Control *Xenopus* responded well to 1 $\mu$ g/ml Con A, whereas Tx animals gave a much reduced response to Con A (see also Green & Cohen, 1979). The addition of 0.1M  $\alpha$ mm to this Con A concentration completely inhibited its ability to induce splenocyte proliferation. In contrast, Con A-induced ASNs from splenocytes treated with this dose of  $\alpha$ mm still produced substantial proliferation of (PHA-induced) splenoblasts and also "unstimulated" splenocytes, suggesting the presence of induced mitotic factor(s) in the ASNs.

Splenocytes from 7 day Tx *Xenopus* proliferated well when given PHA-SNs or Con A-SNs. This was a direct effect of the

SNs and no pretreatment of the cells from the Tx animals was required to make them responsive. This may indicate that although Tx animals display impaired T cell responses, they do possess cells that bear the necessary receptors for the factors in the T cell mitogen-induced SNs. The nature of these cells awaits elucidation; however, the findings presented here suggest that such factors are able to target T-independent cell types. These possibilities are more fully addressed in the following Chapters.

## CHAPTER 4

### DEVELOPMENT OF A MINIATURISED CULTURE SYSTEM TO ASSAY SUPERNATANT ACTIVITY: USE OF CONTROL AND THYMECTOMISED XENOPUS

#### 4.1 INTRODUCTION

In order to further probe the cellular origins and targets of mitogen- and alloantigen-induced culture supernatant activity, it was decided to attempt miniaturisation of the supernatant bioassays. This would allow smaller volumes of culture supernatants to be tested, such economy being of importance when the amount of "potent" SN was limited, for example, when the source of culture SN was from splenocytes removed from early-thymectomised (Tx) animals. Both the numbers of Tx *Xenopus* available for this work and the number of spleen leucocytes cell number obtainable from these animals were limited. Furthermore, miniaturisation of the SN assay culture would also necessitate fewer assay cells, allowing studies on Tx targets to be carried out in some depth.

Weiss and Du Pasquier (1973) were the first to attempt "miniaturisation" of a *Xenopus* lymphocyte culture. They succeeded in culturing thymocytes, which participated in an MLC reaction in 40 $\mu$ l of culture medium (containing a total of  $2 \times 10^5$  lymphocytes per culture well) in the bottom of V-based plates. This MLC response

was as good as when  $5 \times 10^5$  lymphocytes per culture were used in 100 $\mu$ l volumes. They did not attempt to culture fewer than  $2 \times 10^5$  lymphocytes per culture. Weiss and Du Pasquier also noted that FCS supplementation was essential for leucocyte survival and proliferation. Horton *et al* (1980) successfully cultured  $5 \times 10^4$  thymocytes in flat-based Terasaki plates, in 10 $\mu$ l volumes, in their studies on the ontogeny of mitogen reactivity in larval *Xenopus* (see also Williams *et al*, 1983). Unfortunately these cells had to be harvested manually (this procedure was technically difficult and laborious), in contrast to the inverted cultures (see below), for which Terasaki harvesters are available.

Mammalian workers have refined the miniaturisation technique and have been able to measure leucocyte proliferation to PHA (O'Brien *et al*, 1979; Farrant *et al*, 1980), and perform limiting dilution assays (Goodacre *et al*, 1987) and standard mammalian IL-2 assays (J.H. Robinson, University of Newcastle-upon-Tyne, unpublished observations). In these mammalian experiments, cells were cultured in inverted Terasaki plates in the meniscus of a 15-25 $\mu$ l "hanging drop" (Fainboim & Festenstein, 1979). (Cell concentrations ranged from  $1 \times 10^4$  to  $5 \times 10^4$  cells/well).

In this Chapter the inverted Terasaki plate culture system is used to develop a miniaturised SN assay system for use with control and thymectomised *Xenopus* lymphocytes. Further study of 7-day-thymectomised animals was necessary to establish whether splenocytes, in the



absence of T cells, could respond to alloantigen- or mitogen-induced SNs. Furthermore, this Chapter also investigates whether cells from Tx *Xenopus* can produce ASNs following stimulation with T cell mitogen.

Studies on congenitally athymic mice have shown that cytotoxic "T" cells can be identified in these animals *in vitro* (Hünig & Bevan, 1980; Ando & Hurme, 1981) and *in vivo* (Wagner *et al*, 1980), as long as an IL2-rich SN is supplied at the time of antigen or mitogen addition. Other authors have shown that leucocytes from nude mice can produce IL-2 when stimulated with T cell mitogens (MacDonald *et al*, 1982), though to a lesser extent than their euthymic controls (MacDonald & Lees, 1984). In nude mice this production of IL-2 is age associated, increasing amounts of IL-2 being produced with age (Klein & Bevan, 1983; MacDonald & Lees, 1984).

Previous studies on *Xenopus*, thymectomised at 10 days (Cohen, Watkins & Parsons, 1987), a procedure that impairs subsequent allograft rejection, MLC reactivity and PHA responsiveness (see Horton and Sherif, - 1977), revealed that this procedure does not abrogate the ability of splenocytes to produce ASNs following PHA stimulation. Furthermore, culture of leucocytes from 10 day Tx animals with PHA-ASNs and PHA revealed that they became able to display a proliferative response, when tested in PHA and Con A assays. This suggests that the exogenously supplied TCGF may allow the development of T-like cells from Tx animals. Thus far, the situation from the experiments on *Xenopus* by Cohen *et al* reveal a

similar story to that found in the mammalian nude mouse model (Hunig & Bevan, 1980; Ando & Hurme, 1981), in that 10-day-Tx *Xenopus* can produce mitotic factors and their cells can be made responsive to T cell mitogens with prior culture in TCGF-rich SNs (with additional mitogen).

This Chapter has also addressed a technical issue that was noted in Chapter 3. There it was revealed that CRBC-adsorption did not completely eliminate activity of PHA-M. For this reason it was decided that the purified form of this mitogen, PHA-P, should be examined to see if CRBC-adsorption was any more effective at removing mitogenic activity.

## 4.2 MATERIALS AND METHODS

### 4.2.1 Animals

Euthymic *Xenopus* aged 6-12 months were used to generate assay cells. Thymectomy was performed between 7-10 days of larval life, these Tx animals were used at approximately 6 months of age for SN production or for use as assay cells. LM3, LG15 and LG5 clonal animals were used in the following experiments.

#### 4.2.2 Miniaturised assay for supernatant activity using Terasaki plates

Assay cells were adjusted to a concentration of  $1 \times 10^6$  leucocytes/ml in FCS- or BSA- supplemented medium.  $15\mu\text{l}$  aliquots ( $1.5 \times 10^4$  leucocytes) were dispensed into 60-well Terasaki plates (Nunc). [ $1 \times 10^5$  leucocytes per culture well ( $100\mu\text{l}$ ) is used for SN assays in 96-well plates.]  $5\mu\text{l}$  SN (or  $5\mu\text{l}$  mitogen<sup>solution</sup> if mitogen assays were to be carried out in Terasaki plates) was added to bring the "in well" concentration to 25%. Generally, cultures were set up in replicates of five.

Immediately prior to incubation, the plate was inverted and cells were cultured in the meniscus of each "hanging drop" (see diagram to illustrate technique described in Fig. 4.1). Cells were cultured over shallow trays of distilled water to produce sufficient humidity to prevent the small volumes from drying out. Cells were incubated at  $26 \pm 1^\circ\text{C}$  in 5%  $\text{CO}_2$  in air, usually for 48 hours.

For pulsing a 1/10 dilution of [ $^3\text{H}$ ]TdR (Amersham; Sp Act =  $5\text{Ci}/\text{mmol}$ ) was made in AL-15 medium to provide  $1\mu\text{Ci}$  of  $^3\text{H}$ TdR per  $10\mu\text{l}$  medium. Using a Hamilton microsyringe dispenser,  $2\mu\text{l}$  [ $^3\text{H}$ ]TdR ( $0.2\mu\text{Ci}$ ) was dispensed into each well. During pulsing the plate was still held inverted and was slightly tilted so the syringe tip could be introduced at the opposite end of the droplet (where the cells had settled - see Fig. 1b). The cells were then

cultured for a further 20 hours.

To harvest the cells a Titertek microharvester was used (Flow Labs; Fig. 4.1c). The harvesting head has 60 wells, each with a hole in the bottom. The wells correspond to the pattern of wells on the Terasaki plate. A fibre glass filter mat was placed over the harvesting head and small discs were punched out (to lie in each well) using a harvesting punch. The harvesting head, with filters in place, was then transferred to the harvesting main base unit and a vacuum applied. Still holding the tissue culture plate inverted it was placed over the harvesting head. The hanging drops plus cells from individual wells were sucked down onto individual filters. The filters were washed with approximately 500 $\mu$ l double distilled water and dried in an oven at 60°C.

One hour later filters were transferred to vials (Packard; pico hang-in vials), by using a fine needle. 3 mls of scintillation fluid was added (National Diagnostics; Betafluor) and the vials analysed on a scintillation counter (Tricarb 300; Packard). Disintegrations per minute (dpm) were measured for each sample.

#### 4.2.3 Mitogen assay using conventional 96-well plates

These mitogen assays, using the "standard technique" described in earlier Chapters, were performed for two

reasons. Firstly, to compare PHA-P reactivity of *Xenopus* leucocytes in the two media - FCS and BSA-supplemented, in order to find the best conditions for SN generation. Secondly, these mitogen experiments in 96-well plates were to be compared to cells cultured with mitogen in the Terasaki plates.

The assay cells were adjusted to a concentration of  $1 \times 10^6$  leucocytes/ml in either BSA- or FCS- supplemented medium. 100 $\mu$ l aliquots were then dispensed in to 96-well tissue culture plates. PHA-P (Flow Labs) at different concentrations was added in 10 $\mu$ l aliquots to give a range of "in well" concentrations of 0.002 - 1.0  $\mu$ g/ml. Cells were cultured at  $26 \pm 1^\circ\text{C}$  and 5%  $\text{CO}_2$ . After 48 hours culture, each well was pulsed with 1 $\mu$ Ci [ $^3\text{H}$ ]TdR and harvested 24 hours later.

#### 4.2.4 Generation of active supernatants using PHA-P

The same procedure was used to generate mitogen-induced SNs (PHA-P-ASNs) and to remove residual PHA, as in Chapter 3, with 0.2 $\mu$ g/ml PHA-P proving optimal for stimulation. CSNs were <sup>from</sup> leucocytes that had been cultured for 24 hours without PHA-P and then CRBC-treated.

### 4.3 RESULTS

#### 4.3.1 Proliferative responses to PHA-P

##### 4.3.1.1 PHA-P dose response of LM3 splenocytes in "standard" technique; effect of serum supplementation

The optimum PHA-P dose was somewhat different for the two media used (Fig.4.2). In AL-15:FCS(1%) 1 $\mu$ g/ml and 0.2 $\mu$ g/ml of PHA-P elicited excellent splenocyte responses of almost equal magnitude. In AL-15:BSA, splenocytes displayed optimal proliferation with 0.2 $\mu$ g/ml and 0.02 $\mu$ g/ml PHA-P. Background [<sup>3</sup>H]TdR counts were generally higher in the cultures where AL-15:BSA medium had been used, whereas following PHA stimulation, cells cultured in BSA have failed to achieve comparable levels of thymidine incorporation to those kept in FCS. A PHA-P concentration of 0.2 $\mu$ g/ml was subsequently used for the generation of PHA-P-SNs, where we needed to keep serum supplementation to a minimum, by using BSA supplementation.

##### 4.3.1.2 PHA-P dose response of LM3 thymocytes in "standard" technique; effect of serum supplementation

In AL-15:FCS(1%) 1 $\mu$ g/ml PHA-P produced the largest thymocyte response, as measured by [<sup>3</sup>H]TdR incorporation, with 0.2 $\mu$ g/ml also proving stimulatory. In AL-15:BSA,

0.2 $\mu$ g/ml and 1 $\mu$ g/ml PHA-P both achieved substantial thymocyte responses (Fig. 4.3). The highest [ $^3$ H]TdR counts were seen (after PHA stimulation) in the FCS-supplemented medium, rather than in the BSA-supplemented medium.

In the above two sections, both thymocytes and splenocytes came from the same LM3 animal. Splenocytes yielded markedly higher stimulation indices to PHA-P than did thymocytes (Fig. 4.2 & 4.3). For example, the highest SI achieved for thymocytes was 16.0, whereas SIs for splenocytes reached greater than 50. Other experiments (data not shown) confirmed these findings.

#### 4.3.1.3 Reactivity to PHA-P effected by splenocytes cultured in serum free, AL-15:FCS(1%) or AL-15:BSA media in "standard" technique

This experiment was performed in order to determine if AL-15:BSA medium (and even serum-free medium) would be suitable to use in the standard 3 day proliferative assay as a (more defined) replacement for AL-15:FCS(1%). A PHA-P assay was selected to observe how well AL-15:BSA, AL-15:FCS(1%) and unsupplemented AL-15 could support the proliferation of *Xenopus* splenocytes in 96-well plates.

Unsupplemented (serum free) AL-15 could support the proliferation of both populations of splenocytes tested (Table 4.1), but to a lower extent than the other two media, both in terms of dpm and SI. Splenocytes cultured in AL-15:BSA and AL-15:FCS(1%) both yielded high [ $^3$ H]TdR

counts and high SIs. AL-15:FCS(1%) produced a marginally better response from the splenocytes in terms of [<sup>3</sup>H]TdR counts (following PHA stimulation) than AL-15:BSA. Since AL-15:BSA gave excellent splenocyte responses, it was used in experiments 4.3.2.3 and 4.3.2.4 in the miniaturised system.

#### 4.3.1.4 Comparison of standard and miniaturised techniques to measure PHA-P stimulation and effect of CRBC adsorption

PHA-P induced proliferation of splenocytes from an LG5 animal that had been cultured in either 96-well flat-based plates or Terasaki plates (Table 4.2). [<sup>3</sup>H]TdR counts (and SIs) of the assay cells were of a much higher magnitude in the 96-well plates compared to the Terasaki plates. The results from the Terasaki plates, suggested that CRBC-treatment of PHA-P solutions removed virtually all the PHA, since the SIs and dpms in the PHA-P(CRBC-treated) solutions were not significantly different from those of the assay cells cultured in medium alone. However, in the 96-well flat-based plates, where PHA-P induces much greater proliferation, a small, but statistically significant proliferation ( $p < 0.01$ ) was observed for splenocytes cultured in the CRBC-adsorbed PHA solutions.



4.3.2 Use of "standard" and "miniaturised" assays to measure responses to PHA- and MLC- induced supernatants

4.3.2.1 Comparison of PHA-P, PHA-P-SN and MLC-SN on proliferative responses: standard technique

LM3 splenocytes precultured with or without PHA-P and splenocytes assayed after being taken directly from the animal were able to respond by proliferation when cultured with PHA-P, PHA-P-ASNs and MLC-ASNs. The MLC-ASNs appeared to possess less mitotic activity than the two PHA-P-SNs used (Fig. 4.4).

4.3.2.2 Effect of PHA-P, PHA-P-SNs and MLC-SNs on proliferative responses of precultured cells, assayed with the miniaturised technique

This experiment demonstrated that splenocytes precultured with or without PHA-P could be induced to display enhanced proliferation in Terasaki plates in response to PHA-P and both PHA-P-SNs and MLC-SNs (Fig. 4.5). As was the case in the 96-well plates (Fig. 4.4) the PHA-P-ASNs possessed more mitotic activity for the spleen cells than did the MLC-ASNs.

The LG5 cells precultured with PHA-P for 4 days displayed relatively high background counts and were only minimally stimulated by a further dose of PHA-P. This contrasted with the better PHA stimulation index seen in

the equivalent cells that had received no PHA-P during their preculture.

4.3.2.3 Effect of PHA-P , MLC-SNs and PHA-P-SNs on proliferative responses of precultured splenocytes: comparison of standard and miniaturised assays

A good correlation was observed between the spleen cells assayed in the 96-well plates and those assayed in the Terasaki plates (Fig. 4.6). Both systems showed that cells precultured with PHA-P, to produce blasts, gave higher background counts (i.e. when cultured for a further 3 days in medium alone) than the equivalent cells precultured in medium alone. These PHA-P precultured blasts were only minimally stimulated by further PHA-P stimulation, whilst the cells precultured in medium responded well to PHA-P. Cells precultured with PHA-P and then cultured with MLC-ASNs produced SIs of 1.3 & 1.5 ( $p < 0.01$ ), in the miniaturised and standard system, respectively. Spleen cells precultured in BSA supplemented medium responded better to MLC-ASNs than the PHA-P precultured cells giving SIs of 2.5 & 3.0 ( $p < 0.001$ ) for the miniaturised and standard system, respectively. Medium- or PHA- precultured splenocytes assayed in the Terasaki plates responded to PHA-P-ASNs (PHA-P-ASNs were not tested on cells in the 96-well plate).

#### 4.3.2.4 Effect of MLC-SNs and PHA-P-SNs on proliferative responses of precultured thymocytes: comparison of standard and miniaturised techniques

A good correlation was observed for the thymocytes assayed in the 96-well plates and Terasaki plates (Fig. 4.7). Preculturing with PHA-P elevated background [<sup>3</sup>H]TdR levels for thymocytes. Thymocytes precultured without PHA produced only a small response to MLC-ASNs. However, a better response was seen to ASNs when the thymocytes had been precultured with PHA-P. The same was true for thymocytes given PHA-P-ASNs. This was in contrast to splenocytes, which responded equally as well to SNs whether they had been precultured in medium alone or when they had been precultured with PHA-P (see 4.3.2.3). (There were insufficient cells to set up the 96-well plate equivalent).

#### 4.3.3 Studies on 7-day-thymectomised Xenopus

##### 4.3.3.1 Ability of MLC-SNs to induce proliferation of splenocytes from control and thymectomised Xenopus

This experiment, using the standard 96-well assay, clearly demonstrates the inability of splenocytes from a thymectomised animal to respond to PHA-P (Table 4.3). The same thymectomised animal's splenocytes, however,

displayed elevated proliferation in the presence of MLC-ASN as did cells from a second Tx animal. The splenocytes from the single control animal showed an excellent proliferative response when cultured with PHA-P, and a significant response to the MLC-ASN compared with dpm affected by the MLC-CSN.

#### 4.3.3.2 Effect of PHA-P, PHA-SNs and MLC-SNs on proliferative responses of precultured splenocytes from control and thymectomised animals: use of Terasaki plates

When scaled down to the miniaturised system, it was shown that the control animal's splenocytes responded extremely well to a dose of 0.5 and 0.05 $\mu$ g/ml PHA-P [this latter dose was used since this represented the optimum dose - 0.2 $\mu$ g/ml (of the doses studied) used to generate SNs, which is then diluted four times in the SN assay] and also showed a significant proliferative response when cultured with both PHA-P-ASNs and MLC-ASNs. As expected the PHA-P-ASNs possessed more activity than the MLC-ASN (Fig. 4.8).

Compared with the control, the splenocytes from the Tx animal showed a much reduced, but significant, response to 0.5 $\mu$ g/ml and 0.05 $\mu$ g/ml PHA-P. A good proliferative response of the Tx animals cells was recorded when the PHA-P-ASN #1 and also when the MLC-ASN were added (Fig. 4.8). The MLC-ASN appeared to be a more potent stimulator of the splenocytes from the Tx animal.

#### 4.3.3.3 Effect of PHA-P and PHA-P-SNs on proliferative responses of precultured splenocytes from control and thymectomised animals: use of Terasaki plates

This experiment (performed in BSA supplemented medium throughout) confirmed a number of observations (Fig. 4.9). For example, PHA-P- precultured blasts from control animals, produced higher background counts (when cultured with medium alone) than their non-PHA treated counterparts. PHA-P precultured blasts were shown to proliferate poorly in response to further PHA-P treatment, whilst non-PHA-P precultured cells proliferated in response to PHA-P. Both sets of cells proliferated when cultured with PHA-P-ASNs.

Splenocytes from 7-day-Tx animals that had been precultured with or without PHA-P were both refractory to further PHA-P treatment. Both populations of cells, however, responded well to PHA-ASNs.

#### 4.3.3.4 Effect of thymectomy on supernatant generation

This experiment investigated whether splenocytes from 7-day-Tx *Xenopus* could generate active SNs, following culture with PHA-P. Control siblings were also used to generate the positive PHA-P-SNs.

When the PHA-P-SNs were assayed on precultured control cells, those generated from splenocytes of the control animals displayed good mitotic activity (Fig. 4.10). In contrast, the PHA-P-ASN generated from the Tx

animal was much less stimulatory.

The assay splenocytes that had been precultured in the absence of any PHA-P showed higher proliferation to ASNs and PHA-P than the splenocytes which had been precultured with PHA-P to produce "blasts". The latter were, unlike the medium precultured cells, refractory to subsequent PHA stimulation.

FIG. 4.1

A) Cells are cultured in the meniscus of a 20 $\mu$ l "hanging drop".

B) Cells are pulsed with [ $^3$ H]TdR dispensed with a Hamilton syringe.

C) Cells are harvested onto filter discs.

FIG. 4.1

# MINIATURISED CELL CULTURE TECHNIQUE

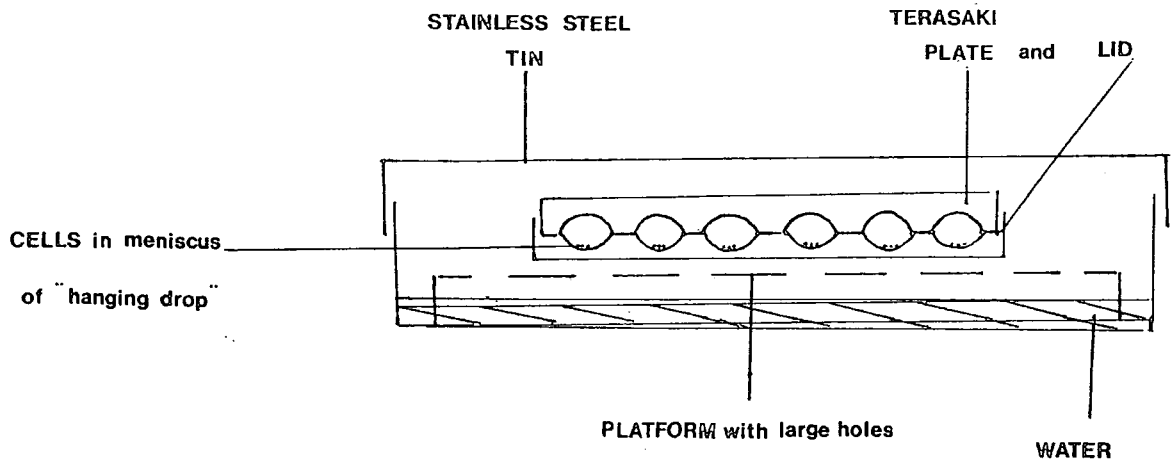

## A) Culture of cells.

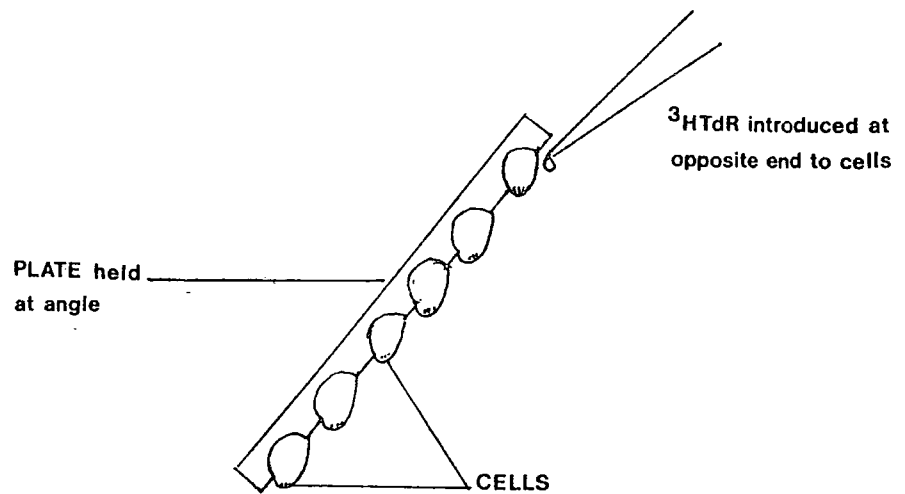

## B) Pulsing the cells.

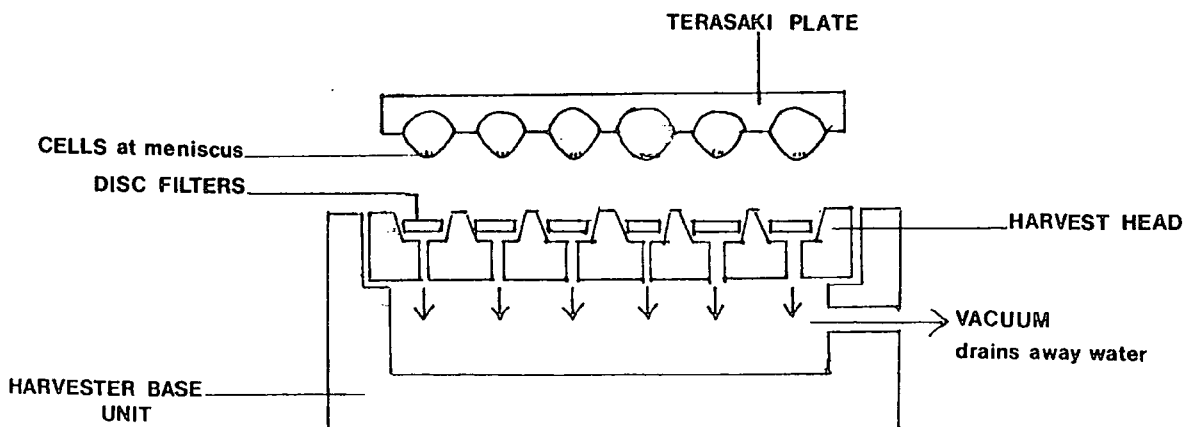

## C) Harvesting.



FIG. 4.2 : "Standard" technique

LM3 splenocytes were dispensed ( $1 \times 10^5$  leucocytes/well) into 96-well V-based plates in AL-15:FCS(1%) or in AL-15:BSA. PHA-P was added to give the following "in well" concentrations of 1.0, 0.2, 0.02, 0.002 $\mu$ g/ml. Cultures were set up in triplicate. After 48 hours of culture, each well was pulsed with 1 $\mu$ Ci [ $^3$ H]TdR and harvested 24 hours later.

FIG. 4.2 PROLIFERATIVE RESPONSES OF LM3 SPLENCYTES TO PHA-P WHEN CULTURED IN BSA- OR FCS-SUPPLEMENTED MEDIA

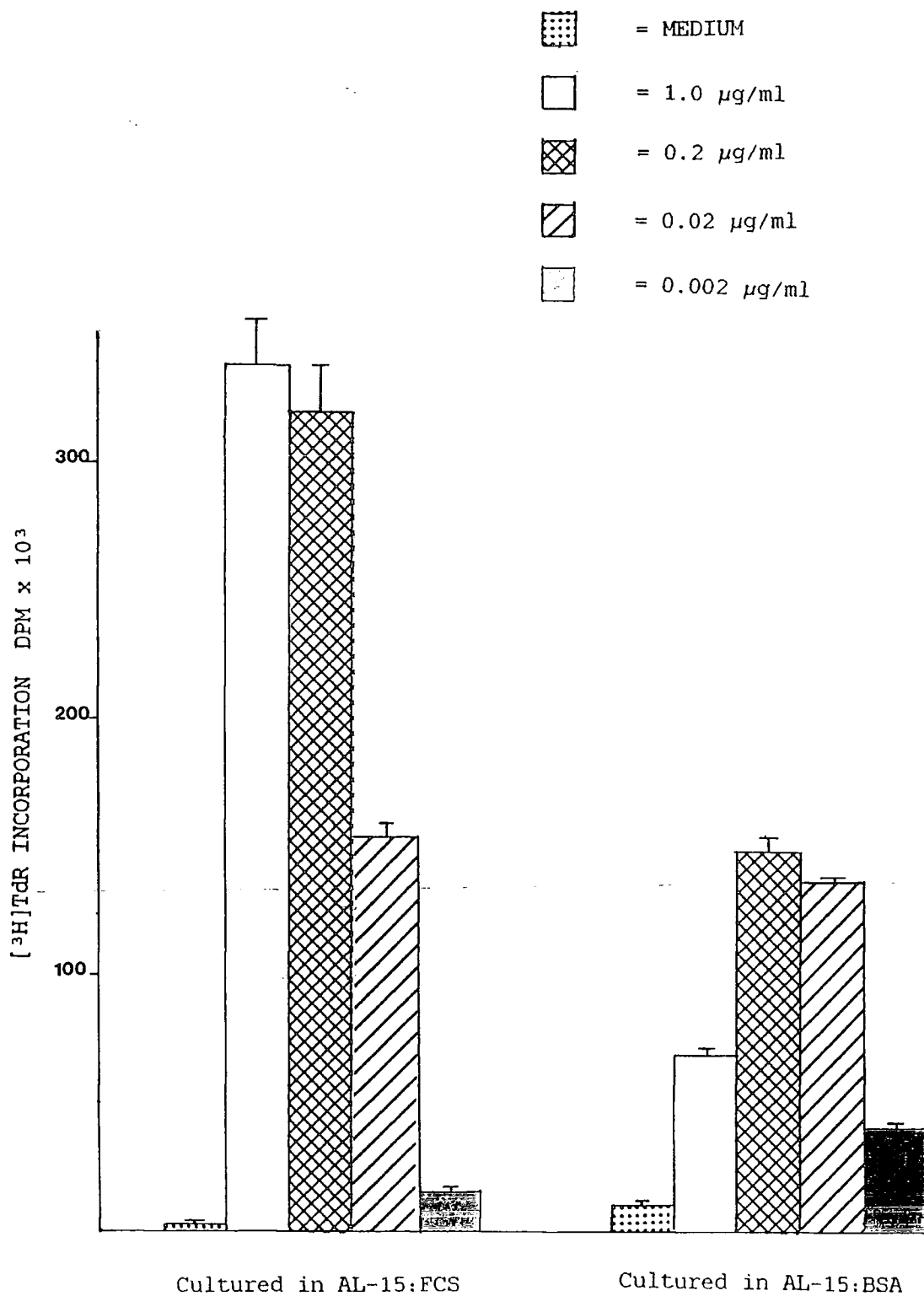

FIG. 4.3 : "Standard" technique

LM3 thymocytes were dispensed ( $1 \times 10^5$  leucocytes/well) into 96-well V-based plates in AL-15:FCS(1%) or in AL-15:BSA. PHA-P was added to give the following "in well" concentrations of 1.0, 0.2, 0.02, 0.002 $\mu$ g/ml. Cultures were set up in triplicate. After 48 hours of culture, each well was pulsed with 1 $\mu$ Ci [ $^3$ H]TdR and harvested 24 hours later.

FIG. 4.3 PROLIFERATIVE RESPONSES OF LM3 THYMOCYTES TO PHA-P WHEN

CULTURED IN BSA- OR FCS- SUPPLEMENTED MEDIA

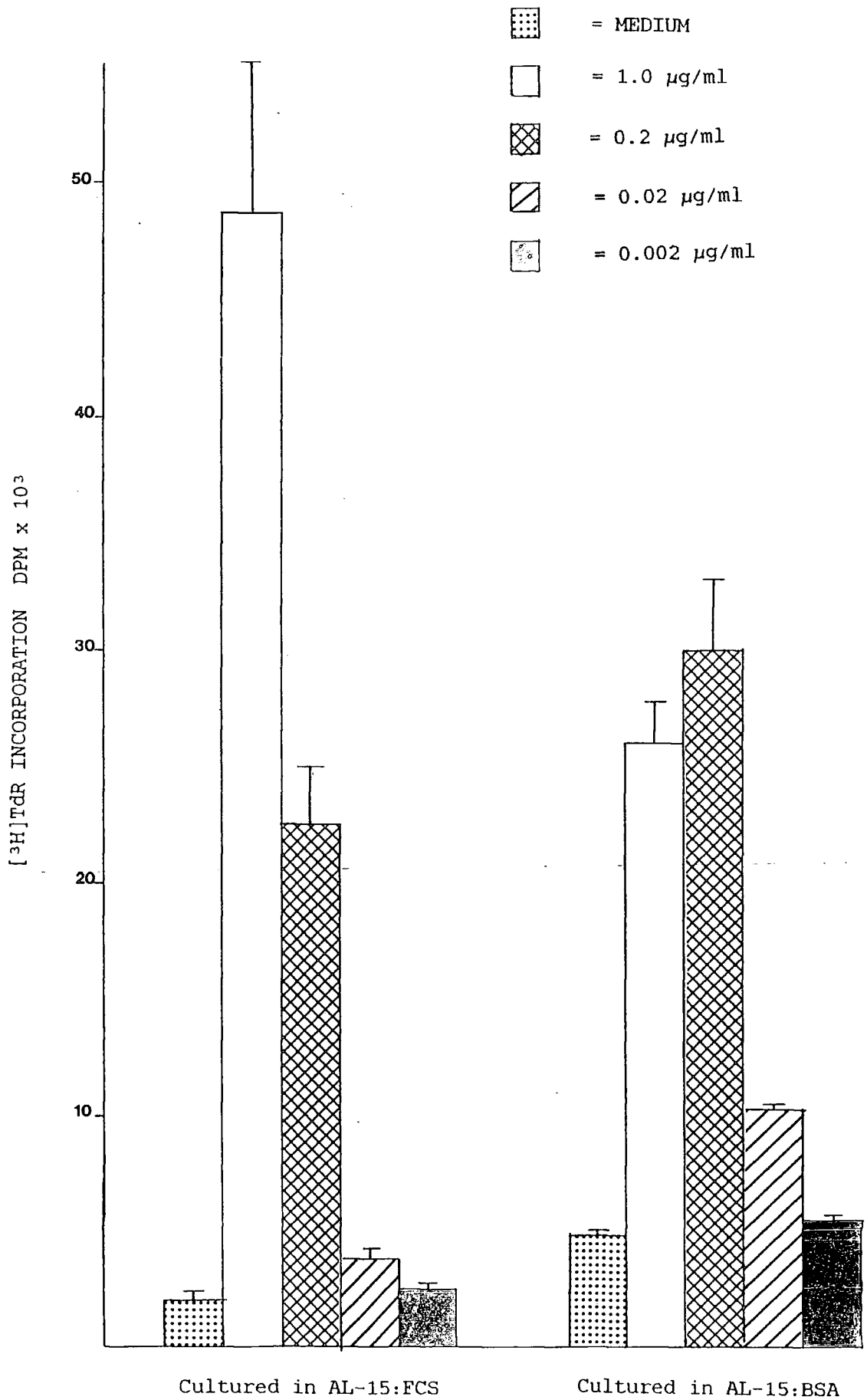

FIG. 4.4 : "Standard" technique

LM3 splenocytes were precultured ( $4 \times 10^6$  leucocytes/ml) in AL-15:FCS(5%) with or without  $0.2\mu\text{g/ml}$  PHA-P. After 8 days the cells were washed and assayed for their ability to respond to PHA-P, PHA-P-SNs (CRBC treated) and MLC-SNs.

Assay cells (8 day precultured and also "fresh" LM3 splenocytes, taken directly from the animal) were dispensed ( $1 \times 10^5$  leucocytes/well) into 96-well V-based plates in AL-15:FCS(1%). SNs were added to bring the final "in well" concentration of SN to 25% in a total volume of  $200\mu\text{l}$ . PHA-P solutions were added to give an "in well" concentration of  $0.05\mu\text{g/ml}$ . All PHA-ASNs were CRBC-passed and the PHA-CSN (black bar in Fig.) was from a culture of non-PHA-treated cells with subsequent CRBC-adsorption of the SN. Cultures were set up in triplicate.

After 48 hours of culture, each well was pulsed with  $1\mu\text{Ci}$  [ $^3\text{H}$ ]TdR and harvested 24 hours later.

FIG. 4.4 COMPARISON OF PHA-P, PHA-P-SNs AND MLC-SNs ON PROLIFERATIVE RESPONSES OF 8 DAY PRECULTURED LM3 SPLENOCYTES

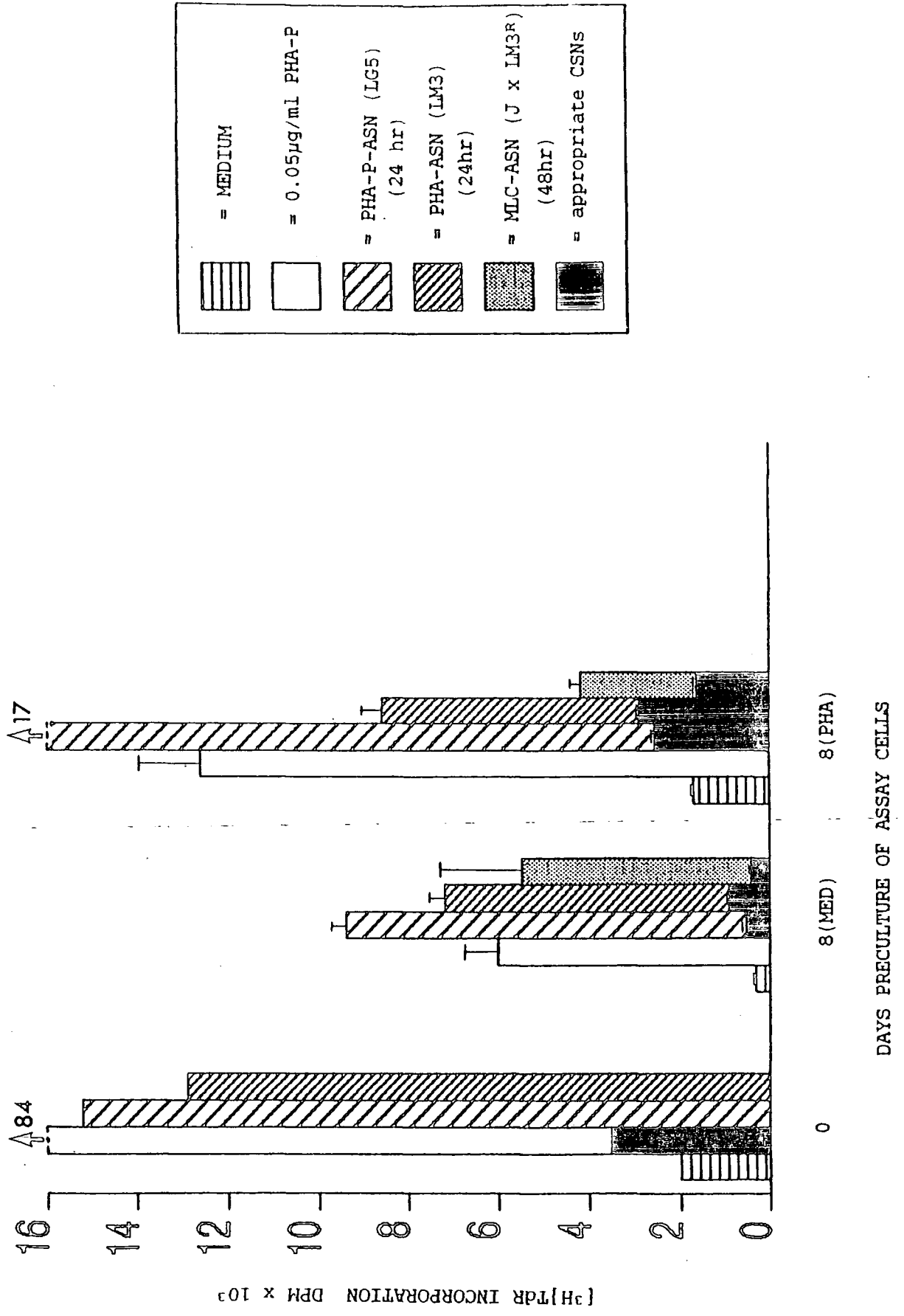

FIG.4.5 : "Miniaturised" technique

LG5 and LM3 splenocytes were cultured for 4 and 8 days, respectively, in AL-15:FCS(5%) with or without PHA-P<sub>k</sub> <sup>(0.05 µg/ml)</sup> to generate assay cells. These were then washed and dispensed ( $1.5 \times 10^4$  leucocytes/well) into Terasaki plates in AL-15:FCS(1%). SNs (PHA-SNs (CRBC treated) and MLC-SNs) were added to bring the final "in well" concentration of SN to 25% in a total volume of 20ul. PHA-P solutions were added to give an "in well" concentration of 0.05 µg/ml (5 µl of 0.2 µg/ml). All PHA-ASNs were CRBC-passed and the PHA-CSN (black bar in Fig.) was from a culture of non-PHA-treated cells with subsequent CRBC-adsorption of the SN. Cultures were set up in replicates of 5.

After 48 hours of culture, each well was pulsed with  $0.2 \mu\text{Ci}$  [<sup>3</sup>H]TdR and harvested 20 hours later.

FIG. 4.5 EFFECT OF PHA-P, PHA-P-SNs AND MLC-SNs ON PROLIFERATIVE

RESPONSES OF PRECULTURED SPLENCYTES: TERASAKI PLATES

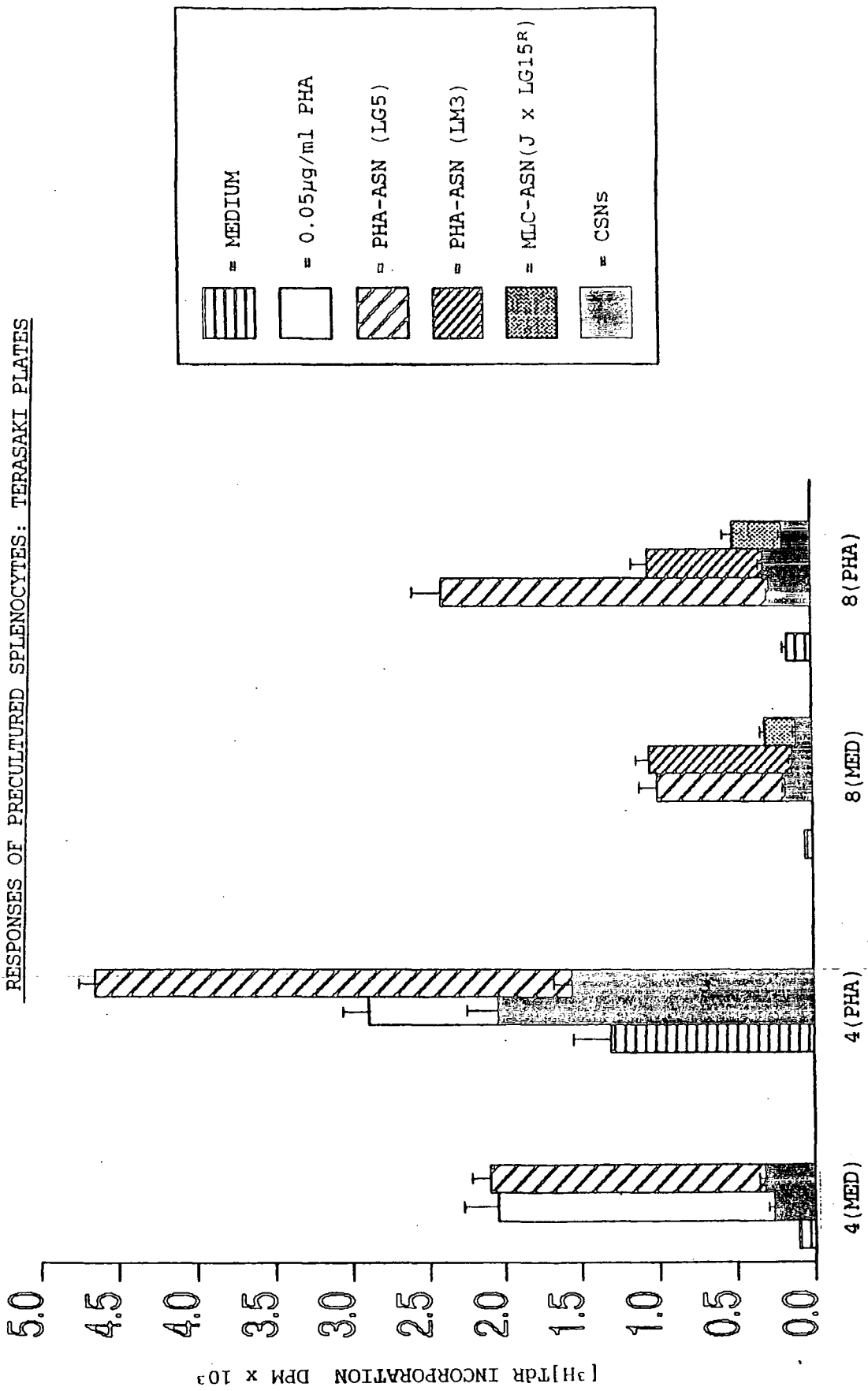

DAYS PRECULTURE OF ASSAY CELLS



FIG. 4.6

LM3 splenocytes were cultured in AL-15:BSA with or without PHA-P<sub>k</sub> (0.2 µg/ml). After 6 days cells were washed and assayed for their response to PHA-P, PHA-P-SNs and MLC-SNs. All PHA-ASNs were CRBC-passed and the PHA-CSN (black bar in Fig.) was from a culture of non-PHA-treated cells with subsequent CRBC-adsorption of the SN. They were now cultured in AL-15:BSA in both 96-well flat-based plates and in Terasaki plates.

96-well plates: Assay cells were dispensed ( $1 \times 10^5$  leucocytes/well) into 96-well plates in AL-15:BSA. SNs were added to bring the final "in well" concentration of SN to 25% in a total volume of 200 µl. PHA-P solutions were added to give an "in well" concentration of 0.5 µg/ml. Cultures were set up in triplicate.

Terasaki plates: Assay cells were dispensed ( $1.5 \times 10^4$  leucocytes/well) into Terasaki plates in AL-15:BSA. SNs (PHA-SNs (CRBC treated) and MLC-SNs) were added to bring the final "in well" concentration of SN to 25% in a total volume of 20 µl. PHA-P solutions were added to give an "in well" concentration of 0.5 µg/ml (5 µl of 2.0 µg/ml). Cultures were set up in replicates of 5.

After 48 hours of culture, each well of the 96-well and Terasaki plate was pulsed with 1 µCi or 0.2 µCi [<sup>3</sup>H]TdR, respectively. Cells from the 96-well plate were harvested 24 hours later. The Terasaki plate was harvested 20 hours later.

FIG. 4.6 EFFECT OF PHA-P, MLC-SNS AND PHA-P-SNS ON PROLIFERATIVE

RESPONSES OF 6 DAY PRECULTURED LM3 SPLEEN CELLS IN



= Medium

TERASAKI AND 96-WELL PLATES

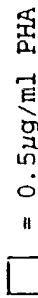

= 0.5 µg/ml PHA

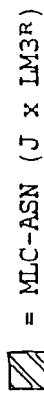

= MLC-ASN (J x LM3R)

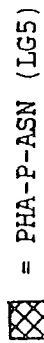

= PHA-P-ASN (LG5)



= CSNs

96-well plate

Terasaki plate

[<sup>3</sup>H]TDR INCORPORATION DPM x 10<sup>3</sup>

[<sup>3</sup>H]TDR INCORPORATION DPM x 10<sup>3</sup>

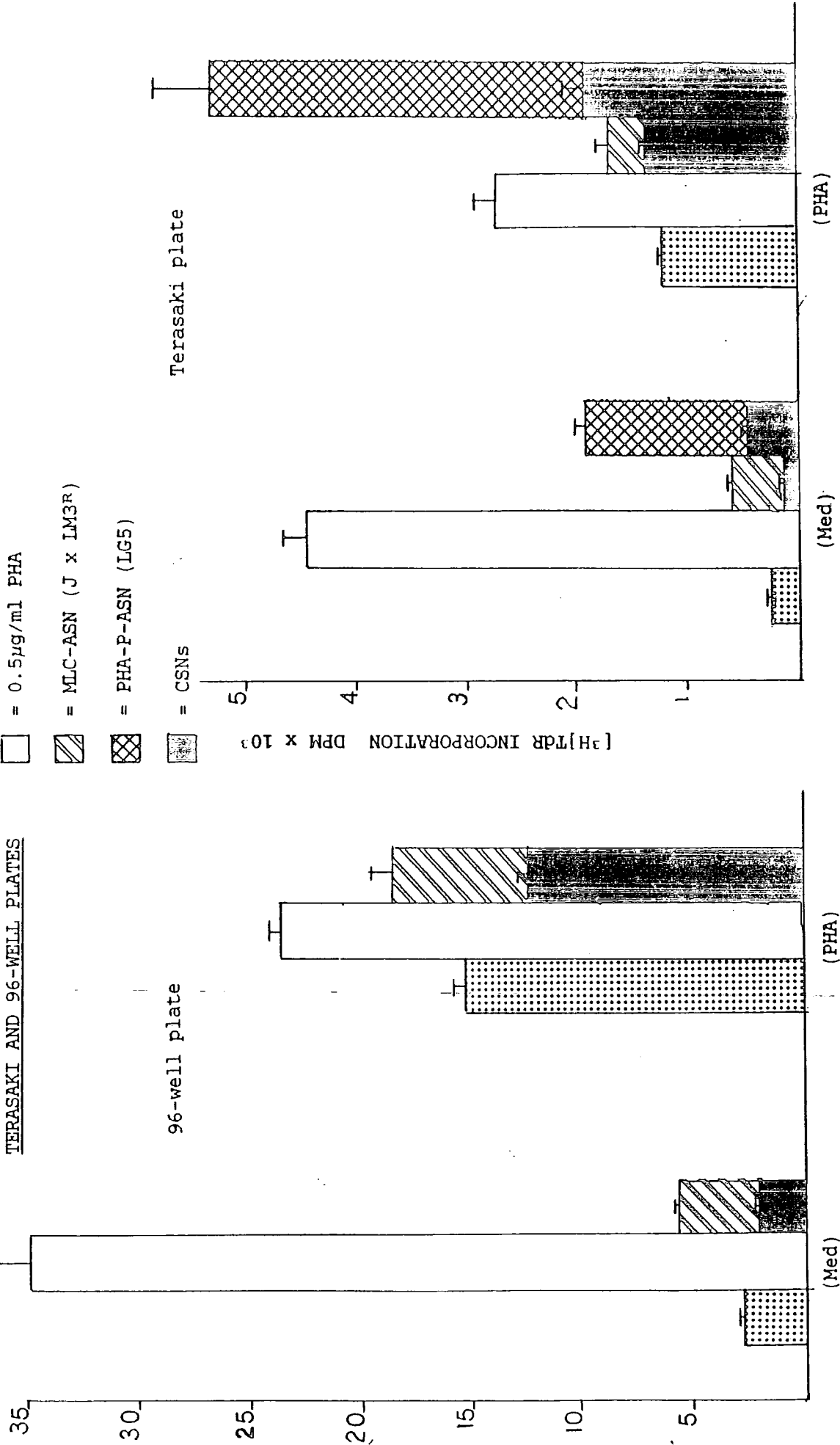

(Med)

(PHA)

(Med)

(PHA)

6 DAYS PRECULTURE OF ASSAY CELLS

FIG.4.7

LM3 thymocytes ( $4 \times 10^6$  leucocytes/ml) were cultured in AL-15:BSA for 4 or 6 days with or without PHA-P<sub>k</sub> <sup>(0.2 µg/ml)</sup>. These assay cells were then washed and dispensed in 96-well plates or Terasaki plates. [All PHA-ASNs were CRBC-passed and the PHA-CSN (black bar in Fig.) was from a culture of non-PHA-treated cells with subsequent CRBC-adsorption of the SN.]

96-well plates: Assay cells were dispensed ( $1 \times 10^5$  leucocytes/well) into 96-well plates in AL-15:BSA. SNs were added to bring the final "in well" concentration of SN to 25% in a total volume of 200 µl. Cultures were set up in triplicate.

Terasaki plates: Assay cells were dispensed ( $1.5 \times 10^4$  leucocytes/well) into Terasaki plates in AL-15:BSA. SNs (PHA-SNs (CRBC treated) and MLC-SNs) were added to bring the final "in well" concentration of SN to 25% in a total volume of 20 µl. Cultures were set up in replicates of 5.

After 48 hours of culture, each well of the 96-well and Terasaki plate was pulsed with 1 µCi or 0.2 µCi [<sup>3</sup>H]TDR, respectively. Cells from the 96-well plate were harvested 24 hours later. The Terasaki plate was harvested 20 hours later.

[All PHA-ASNs were CRBC-passed and the PHA-CSN (black bar in Fig.) was from a culture of non-PHA-treated cells with subsequent CRBC-adsorption of the SN.]

FIG. 4.7 EFFECT OF MLC-SNs AND PHA-P-SNs ON PROLIFERATIVE RESPONSES OF 4 DAY AND 6 DAY PRECULTURED LM3 THYMOCYTES IN TERASAKI AND 96-WELL PLATES

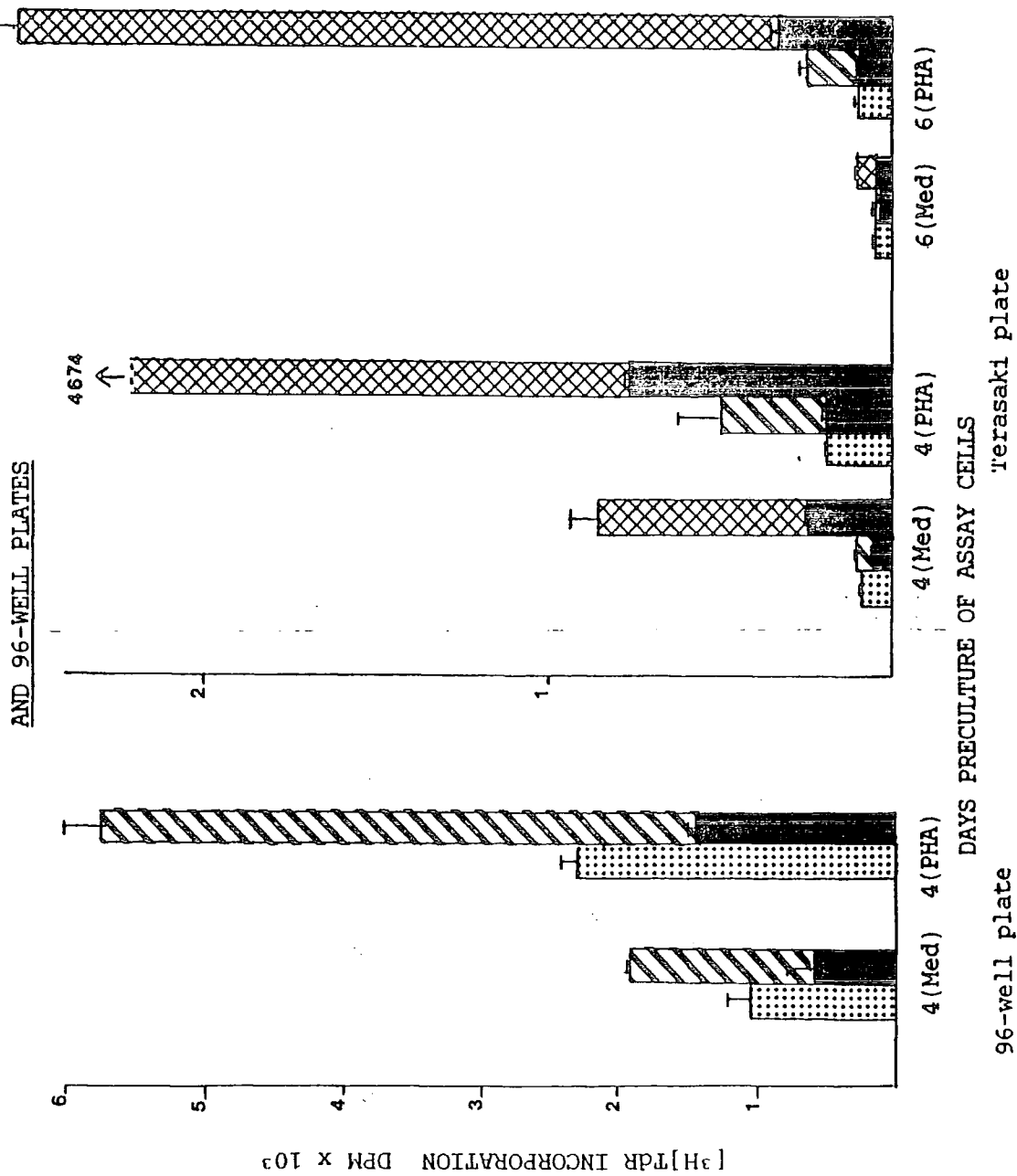
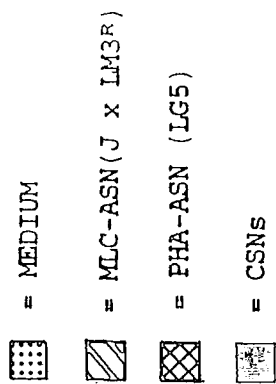

FIG. 4.8 : "Miniaturised" technique

Assay cells (LM3 splenocytes from control and 7 day Tx animals) were precultured ( $4 \times 10^6$  leucocytes/ml) in AL-15:FCS(5%) for 4 days. Assay cells were dispensed ( $1.5 \times 10^4$  leucocytes/well) into Terasaki plates in AL-15:BSA. SNs [PHA-ASNs (CRBC-treated), PHA-CSNs (SNs from cultures of syngeneic cells that were CRBC-treated) and MLC-SNs] were added to bring the final "in well" concentration of SN to 25% in a total volume of 20 $\mu$ l. 5 $\mu$ l of 0.2 $\mu$ g/ml or 2.0 $\mu$ g/ml of PHA-P solution were added to give a final "in well" concentration of 0.05 and 0.5 $\mu$ g/ml. Cultures were set up in replicates of 5.

After 48 hours of culture, each well was pulsed with 0.2 $\mu$ Ci [ $^3$ H]TdR, and harvested 20 hours later.

FIG 4.8 EFFECT OF PHA-P, PHA-P-SNs AND MLC-SNs ON PROLIFERATIVE RESPONSES OF 4 DAY PRECULTURED SPLENOCYTES FROM LM3 CONTROL AND THYMECTOMISED XENOPUS IN TERASAKI PLATES

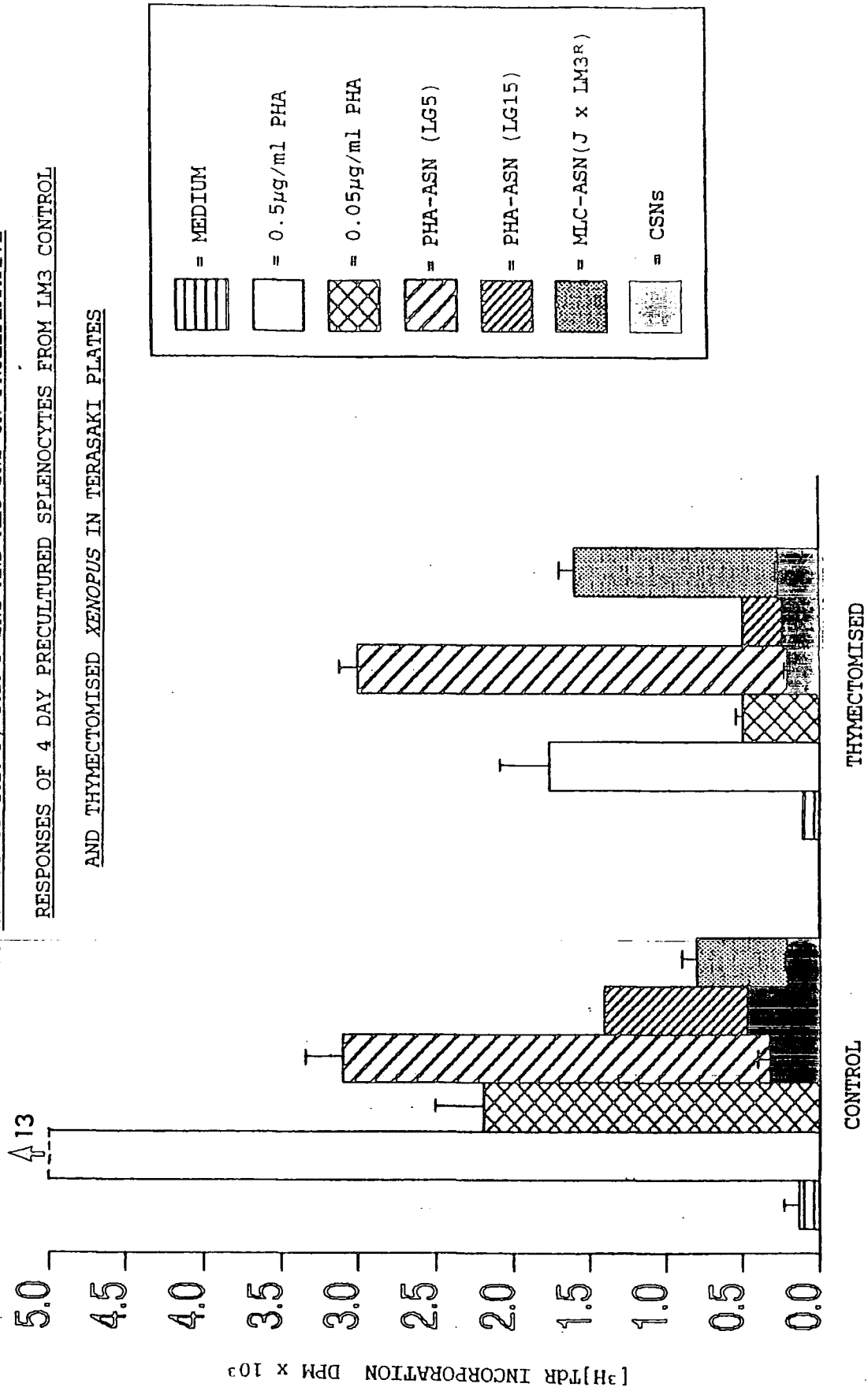
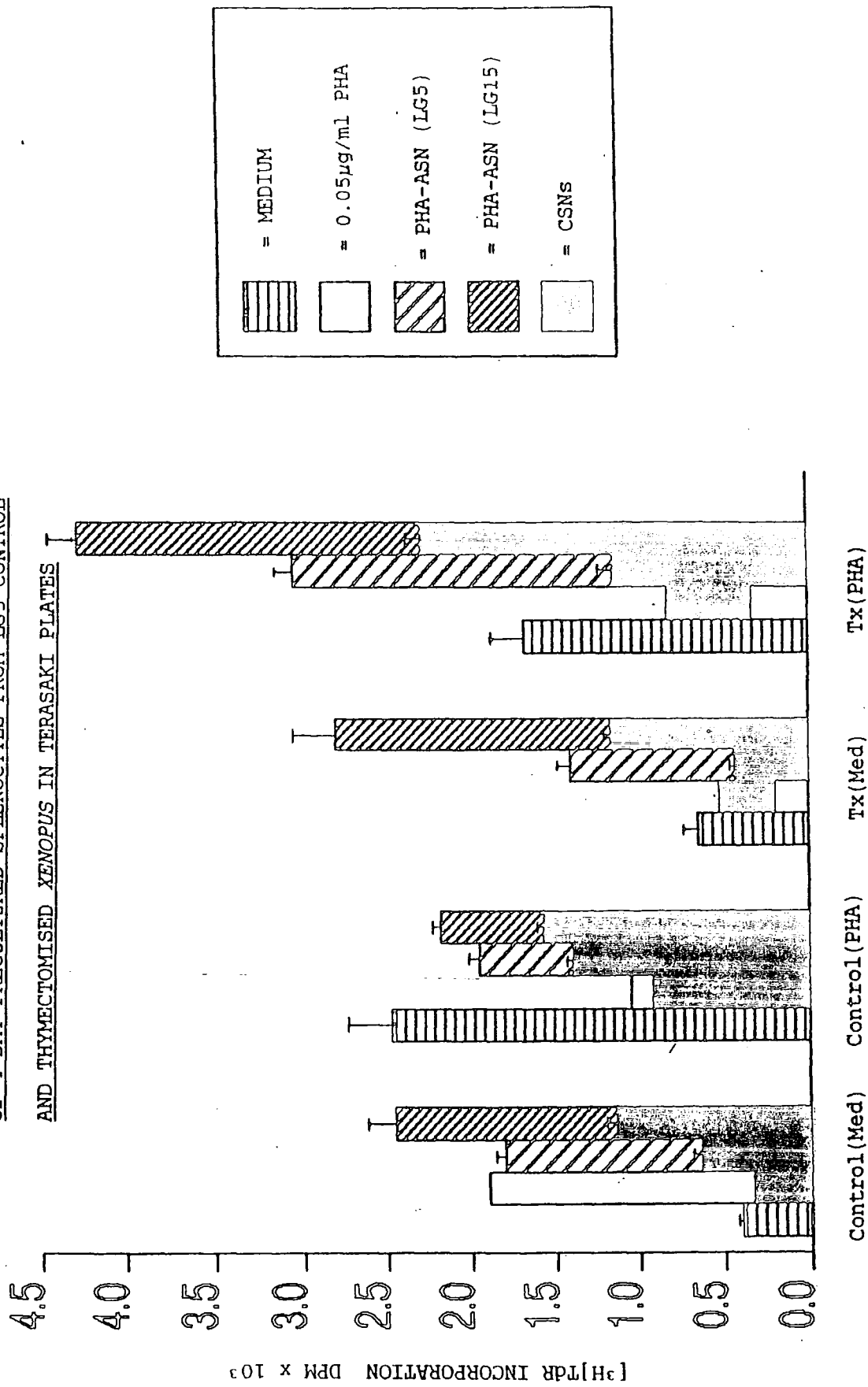

FIG. 4.9 : "Miniaturised" technique

Assay cells (LG5 splenocytes from control and 7 day Tx animals) were precultured in AL-15:BSA with or without PHA-P for 4 days. They were washed and dispensed ( $1.5 \times 10^4$  leucocytes/well) into Terasaki plates in AL-15:BSA. SNs [PHA-ASNs (CRBC-treated), PHA-CSNs (SNs from cultures of syngeneic cells that were CRBC-treated)] were added to bring the final "in well" concentration of SN to 25% in a total volume of  $20\mu\text{l}$ .  $5\mu\text{l}$  of  $0.2\mu\text{g/ml}$  PHA-P solution was added to give a final "in well" concentration of  $0.05\mu\text{g/ml}$ . Cultures were set up in replicates of 5.

After 48 hours of culture, each well was pulsed with  $0.2\mu\text{Ci}$  [ $^3\text{H}$ ]TdR, and harvested 20 hours later.

FIG 4.9 EFFECT OF PHA-P AND PHA-P-SNs ON PROLIFERATIVE RESPONSES  
 OF 4 DAY PRECULTURED SPLENOCYTES FROM LG5 CONTROL  
 AND THYMECTOMISED XENOPUS IN TERASAKI PLATES



4 DAYS PRECULTURE OF ASSAY CELLS

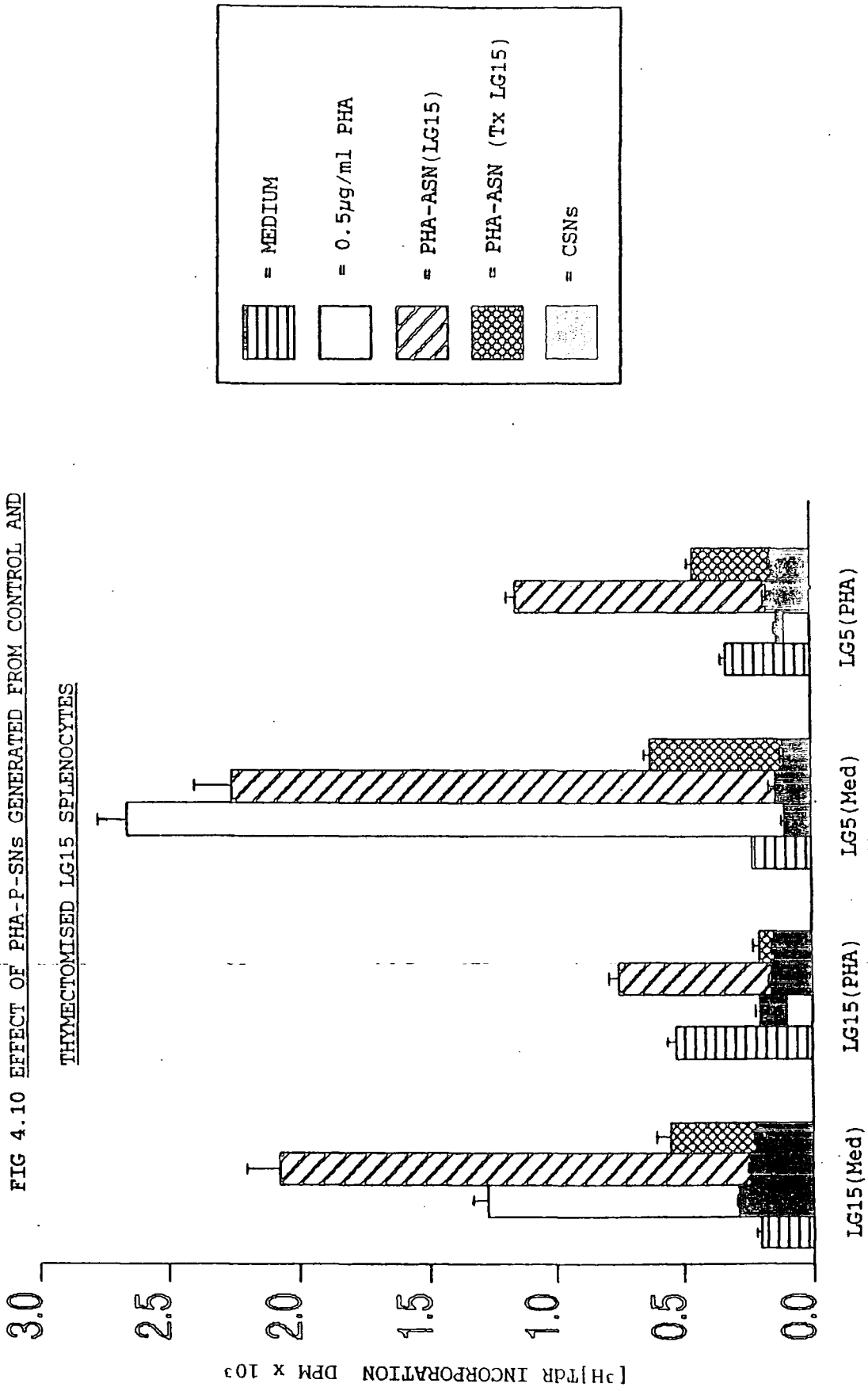

FIG. 4.10 : "Miniaturised" technique

24 hour PHA-P-SNs were generated from LG15 control and 7-day-Tx animals, using the standard procedure. Assay cells (LG15 and LG5 splenocytes) were precultured ( $4 \times 10^6$  leucocytes/ml) in AL-15:BSA with or without PHA-P for 8 days. They were then washed and dispensed ( $1.5 \times 10^4$  leucocytes/well) into Terasaki plates in AL-15:BSA. SNs [PHA-ASNs (CRBC-treated), PHA-CSNs (SNs from cultures of syngeneic cells that were CRBC-treated)] were added to bring the final "in well" concentration of SN to 25% in a total volume of  $20 \mu\text{l}$ .  $5 \mu\text{l}$  of  $2.0 \mu\text{g/ml}$  PHA-P solution was added to give a final "in well" concentration of  $0.5 \mu\text{g/ml}$ . Cultures were set up in replicates of 5.

After 48 hours of culture, each well was pulsed with  $0.2 \mu\text{Ci}$  [ $^3\text{H}$ ]TdR, and harvested 20 hours later.

FIG 4.10 EFFECT OF PHA-P-SNs GENERATED FROM CONTROL AND THYMECTOMISED LG15 SPLENOCYTES



8 DAYS PRECULTURE OF ASSAY CELLS

TABLE 4.1

Assay cells were dispensed ( $1 \times 10^5$  leucocytes/well) into 96-well V-based plates. Splenocytes were cultured in serum-free, AL-15:FCS(1%) or in AL-15:BSA media. Splenocytes were cultured in medium alone or given PHA-P. Cultures were set up in triplicate.

After 48 hours of culture, each well was pulsed with  $1\mu\text{Ci}$  [ $^3\text{H}$ ]TdR and harvested 24 hours later.

$$\text{SI} = \frac{\text{cultures+PHA soln. (dpm)}}{\text{cultures+medium (dpm)}}$$

TABLE 4.1 EFFECT OF PHA-P ON PROLIFERATIVE RESPONSES OF SPLENOCYTES  
 CULTURED IN SERUM-FREE, AL-15:FCS(1%) OR AL-15:BSA MEDIA

| assay<br>splenocytes | assay splenocytes cultured in:            |   |  |                         | mean dpm $\pm$ sem<br>[SI] |
|----------------------|---|---|--|-------------------------|----------------------------|
|                      | serum-free<br>" + PHA-P                   | BSA medium<br>" + PHA-P                     | FCS medium<br>" + PHA-P                    | FCS medium<br>" + PHA-P |                            |
| wild                 | 159 $\pm$ 19<br>3185 $\pm$ 170<br>[20.0]  | 206 $\pm$ 54<br>9273 $\pm$ 259<br>[45.0]    | 344 $\pm$ 140<br>12869 $\pm$ 348<br>[37.0] |                         |                            |
| LG17                 | 497 $\pm$ 56<br>11115 $\pm$ 485<br>[22.0] | 769 $\pm$ 222<br>43756 $\pm$ 1623<br>[57.0] | 355 $\pm$ 17<br>55516 $\pm$ 514<br>[156.0] |                         |                            |

TABLE 4.2

PHA-P solutions of 2.0 and 0.2 $\mu$ g/ml were prepared and either CRBC-treated or left untreated. The solutions were then assayed using LG5 splenocytes. LG5 splenocytes were assayed in 96-well flat-based plates or Terasaki plates.

96-well plates: splenocytes were dispensed ( $1 \times 10^5$  leucocytes/well) in AL-15:FCS(1%) in a total volume of 200 $\mu$ l. Cultures were set up in triplicate.

Terasaki plates: splenocytes were dispensed ( $1.5 \times 10^4$  leucocytes/ml) in AL-15:FCS(1%) in a total volume of 20 $\mu$ l. Cultures were set up in replicates of 5.

After 48 hours of culture, each well of the 96-well or Terasaki plate was pulsed with 1 $\mu$ Ci or 0.2 $\mu$ Ci [ $^3$ H]TdR, respectively. Cells from the 96-well plates were harvested 24 hours later. The Terasaki plates were harvested 20 hours later.

$$\text{SI} = \frac{\text{cultures + PHA soln. (dpm)}}{\text{cultures + medium (dpm)}}$$

TABLE 4.2 COMPARISON OF PROLIFERATIVE RESPONSES TO PHA-P OF SPLENOCYTES CULTURED IN 96-WELL OR TERASAKI PLATES

| type of plate | LG5 splenocytes cultured with: |                    |                       |                         |
|---------------|--------------------------------|--------------------|-----------------------|-------------------------|
|               | medium                         | PHA-P (2μg/ml)     | PHA-P (CRBC) (2μg/ml) | PHA-P (CRBC) (0.2μg/ml) |
|               | mean dpm ± sem [SI]            |                    |                       |                         |
| 96-well       | 737 ± 17                       | 25186 ± 145 [34.0] | 2153 ± 64 [2.9]       | 27119 ± 636 [36.0]      |
| Terasaki      | 52 ± 4                         | 282 ± 145 [5.4]    | 60 ± 6 [1.2]          | 447 ± 58 [8.6]          |
|               |                                |                    |                       | 2305 ± 249 [3.1]        |
|               |                                |                    |                       | 58 ± 3 [1.1]            |

CRBC = solns have been adsorbed over CRBC

TABLE 4.3

Assay cells ("fresh" splenocytes from 7-day-Tx and control LG5) were dispensed ( $1 \times 10^5$  leucocytes/well) into 96-well plates in AL-15:FCS(1%). SNs were added to bring the final "in well" concentration of SN to 25% in a total volume of 200 $\mu$ l. 50 $\mu$ l of 2.0 $\mu$ g/ml PHA-P slution was added to give an "in well" concentration of 0.5 $\mu$ g/ml. Cultures were set up in triplicate.

After 48 hours of culture, each well of the 96-well plate was pulsed with 1 $\mu$ Ci and harvested 24 hours later.

PHA-P cultures (dpm)

(PHA-P) SI = \_\_\_\_\_

medium cultures (dpm)

ASN cultures (dpm)

(SN) SI = \_\_\_\_\_

CSN cultures (dpm)

TABLE 4.3 EFFECT OF MLC-SNS ON PROLIFERATIVE RESPONSES OF SPLENOCYTES  
 FROM LG5 CONTROL AND THYMECTOMISED XENOPUS

| LG5<br>assay<br>cells | assay splenocytes cultured with : |                         |   |
|-----------------------|-----------------------------------|-------------------------|---|
|                       | medium                            | PHA-P<br>(0.5µg/ml)     | MLC-CSN (J x JR)<br>MLC-ASN (J x LG15R) |
|                       | mean dpm ± sem<br>[SI]            |                         |   |
| control<br>"fresh"    | 7484 ± 459                        | 162626 ± 2192<br>[22.0] | 2676 ± 102<br>7538 ± 553<br>[2.8]       |
| Tx 1<br>"fresh"       | 4011 ± 678                        | 2551 ± 695<br>[0.6]     | 1813 ± 166<br>8615 ± 169<br>[4.8]       |
| Tx 2<br>"fresh"       | 5137 ± 23                         | n.d.                    | 4366 ± 177<br>10713 ± 524<br>[2.5]      |



#### 4.4 DISCUSSION

These experiments are the first to demonstrate that a miniaturised, hanging drop culture technique can be successfully used for the culture of amphibian cells. As few as  $1.5 \times 10^4$  *Xenopus* leucocytes could be cultured in the meniscus of a  $20\mu\text{l}$  hanging drop, compared with the  $1 \times 10^5$  leucocytes per well usually employed when proliferative assays are carried out in 96-well plates. Slight modifications of the mammalian technique were necessary to optimise conditions for amphibian cells. For example, the pulse time for mammalian hanging drop cultures in Terasaki plates is usually far shorter than the 20 hours used in the *Xenopus* system (Farrant *et al*, 1980). Shorter pulse times in the amphibian miniaturised cultures gave too few thymidine counts to be of any meaningful value (data not shown).

The response of leucocytes cultured in inverted fashion in Terasaki plates correlated closely with that of cells cultured conventionally in the 96-well plates. Although actual counts recorded for the miniaturised system were of a lower magnitude than the counts from the 96-well plates, the SIs of the two systems were often similar. The correlation was true for all the parameters measured, including PHA responsiveness and the response to PHA-P-SNs and MLC-SNs.

AL-15:FCS(1%) and AL-15:BSA both supported

proliferation of leucocytes cultured in PHA, or with PHA-SNs or MLC-SNs in the two systems, i.e. miniaturised and standard. AL-15:BSA was used in order to better define the culture medium. After performing numerous experiments (not all data shown) it became apparent that although AL-15:BSA gave adequate results, more consistent results and better assay cell viability were obtained when using medium supplemented with FCS.

Experiments with PHA-P-SNs (both standard and miniaturised systems) revealed that splenocytes from control *Xenopus* not intentionally stimulated could respond to such factors (see also Chapter 3). In contrast, thymocytes cultured in the Terasaki system, as with the 96-well system, showed a heightened response to the SNs especially following their preculture with T cell mitogen. This observation is in agreement with Watkins and Cohen (1987) who noted the ability of *Xenopus* mitogen-precultured thymocytes to respond to their mitogen-induced SNs (containing TCGF). Our experiments, therefore, indicate the involvement of a TCGF.

Our understanding of T cell maturation in *Xenopus* is at an early stage of investigation. To date, the only reagent that specifically labels *Xenopus* T cells is the XT-1 McAb of Nagata, 1985. This antibody raised against thymocytes, labels >95% thymocytes from many strains of *Xenopus*. It also labels a proportion of peripheral T cells, but is not a pan T cell marker. The antibody labels an antigen - XTLA-1. Until further antibodies are produced that recognise other T cell determinants, the

precise sequence of stages in maturation in the *Xenopus* thymus will remain uncertain. Nevertheless, following surgical thymectomy (Tx) at 7 days of age, XT-1+<sup>ve</sup> lymphocytes are effectively depleted from the spleen, as revealed by Nagata (1986) and confirmed by our laboratory (by flow cytometry) for siblings of the animals used here in this Thesis following Tx at 5 or 7 days by microcautery (Varley, Ph.D thesis, 1990). Despite this lack of XT-1+<sup>ve</sup> lymphocytes, Tx animals splenocytes could still respond by proliferation to both PHA-P-ASNs and MLC-ASNs. The Terasaki plate culture system proved useful here, since numbers of leucocytes in Tx animals were reduced compared with controls.

At present, the precise nature of the cells that are proliferating on addition of ASNs (in Tx and control *Xenopus*) is a matter of conjecture.

The ability of 7-day-Tx animals' splenocytes a) to respond minimally to PHA-P and b) to secrete "low activity" ASNs upon mitogen stimulation, suggests the existence in these animals of such "T-like" cells. Residual responses to T cell mitogens by certain density gradient fractions of cells derived from Tx *Xenopus* have also been described by Green, Donnelly & Cohen (1979). It seems such Tx toads still possess a few cells that are functionally equivalent to the mature T cells found in euthymic *Xenopus*. It is possible, therefore, that these XTLA-1-, T-like cells sometimes found in Tx *Xenopus* (see also Nagata & Cohen, 1983) are responsible for the enhanced thymidine incorporation observed when

splenocytes from Tx animals are cultured with MLC-ASNs or PHA-ASNs. [The possibility that these T-like cells in Tx *Xenopus* are produced extrathymically has been suggested elsewhere (see Nagata & Cohen, 1983).]

Alternatively, since Tx animals are deficient in a whole array of T cell responses (Manning, Donnelly & Cohen, 1976; Horton & Sherif, 1977; Horton & Manning, 1972; Du Pasquier & Horton, 1976; Nagata & Cohen, 1983; Green, Donnelly & Cohen, 1979; Manning & Collie, 1977; Williams *et al*, 1973) ), it seems likely that, at least in Tx frogs, some other cell type responds to the ASNs, e.g. B cells. The possibility that B cells are being targetted by the SNs is examined in the following Chapter. It is also reasonable to assume that the SNs may contain a variety of lymphokines which may target a number of different cell types (see Chapter 3).

## CHAPTER 5

### USE OF ANTI-IgM MONOCLONAL ANTIBODY TO EXPLORE THE NATURE OF SPLENOCYTES RESPONSIVE TO CULTURE SUPERNATANTS

#### 5.1 INTRODUCTION

Studies with splenocytes from Tx *Xenopus* have suggested that, although ASN production is thymus-dependent, ASNs may be able to stimulate cells other than T lymphocytes.

In mice, there is evidence to suggest that IL-2 is ineffective at causing the proliferation of resting B cells (Boom, Liano & Abbas, 1988; Killar *et al*, 1987). However, in both mice and humans there are many reports of Ig-activated (cells activated through recognition of their surface Ig by antibody) B blasts proliferating in response to IL-2 (affinity purified from T cell mitogen cultures) (Puré *et al*, 1981; Melchers *et al*, 1980; Nakanishi *et al*, 1984; Prakash *et al*, 1985). Later studies revealed that such mammalian B blasts could also respond to recombinant IL-2 (rIL-2) (Hashimoto *et al*, 1986; Nakagawa *et al*, 1985; Zubler *et al*, 1984; Reynolds, Boom & Abbas, 1987). IL-2 receptors have been found on B blasts, but not fresh (unstimulated) B cells (Zubler *et al*, 1984; Tsudo, Uchiyama & Uchino, 1984). With the use of radiolabelled rIL-2 or McAbs reactive with the p55  $\beta$  chain of the IL-2 receptor (IL-2R), it has been shown that B blasts (i.e. activated B cells) express the p55  $\beta$

chain at only a tenth of the density expressed by activated T cells (i.e. T blasts) (Nakanishi *et al*, 1984; Muraguchi *et al*, 1985).

Karasuyama *et al* (1988) propose that IL-2 possesses a B cell growth factor (BCGF) beta activity. BCGF-alpha acts in the late G<sub>1</sub> phase of the cell cycle, after initial activation of the B cell e.g. through anti-Ig stimulation (G<sub>0</sub> - G<sub>1</sub>). BCGF- $\alpha$  regulates the entry of the B cell into S and G<sub>2</sub> phase. BCGF- $\beta$  is then able to push the activated B cell into mitosis (G<sub>2</sub> - M).

Despite the demonstration that rIL-2 can promote mitosis of B blasts, the magnitude of the proliferative responses of B cells in cultures supported by rIL-2 alone has usually been smaller than when compared with those maintained by mitogen-derived SNs containing a variety of T cell-derived lymphokines (Nakagawa *et al*, 1985; Jung, Hara & Man Fu, 1984). In addition, the concentrations of rIL-2 required to promote B cell responsiveness have usually been several orders of magnitude higher compared with those necessary to maintain T cell growth (Jung, Hara & Man Fu, 1984; reviewed by Jelinek & Lipsky, 1987). Since the concentrations of rIL-2 used to promote B cell responsiveness are greater than would be found under physiological conditions, the role that IL-2 may play on B cell differentiation *in vivo* is unclear.

Interestingly, when investigating the release of lymphokines in the murine MLC response, the existence of a BCGF with proliferative activity for B blasts (generated through surface anti-Ig stimulation) was

demonstrated (Puré, Inaba & Metlay, 1988). It was revealed that the majority of this activity was distinct from IL-2, since an anti-IL-2 antibody reduced this response by about 20% only.

In this Chapter, one major goal was to determine if, in Tx *Xenopus*, B cells are responding to the MLC- and mitogen-induced ASNs. It is possible to separate B cells from a population of *Xenopus* leucocytes, on the basis of the constitutive expression of immunoglobulin (Ig) found on the surface of B cells. The principal Ig expressed on the surface of unstimulated *Xenopus* leucocytes is IgM (Hadji-Azimi, Schwager & Thiébaud, 1982). McAbs reactive with *Xenopus* IgM have been produced (Bleicher & Cohen, 1981; Langeberg *et al*, 1987). These McAbs have been used to "pan" for surface IgM positive (sIgM+) leucocytes (Bleicher & Cohen, 1981; Schwager & Hadji-Azimi, 1985; Langeberg *et al*, 1987). Although "panning" (using anti-Ig plastic coated petri dishes) is a reasonable method for enrichment or depletion of cell populations, there is invariably some cross-contamination of leucocytes. Another way of separating cell populations via the use of McAbs is by using a fluorescent activated cell sorter (FACS). If a McAb to a particular cell surface determinant is conjugated (through its Fc region) with a fluorescent marker, e.g. fluorescein-isothiocyanate (FITC; which fluoresces green under UV illumination), cells bearing that cell surface determinant can readily be distinguished from unlabelled cells, following incubation with the antibody. This is a "direct" way of

labelling cells. A secondary, fluorescent-labelled antibody directed against a non-fluorescent primary antibody (i.e. an antibody that recognises the cell surface antigen under study), can also be used to visualise the cell. A FACS is able to distinguish and separate fluorescent-labelled cells from unlabelled cells with a high degree of accuracy (reviewed by Shapiro, 1987). A disadvantage of using a FACS machine is that the sorting of cells into positive (fluorescent-labelled) and negative (no antibody labelling) populations is a time-consuming procedure. However, it was hoped that by using the (Terasaki plate) miniaturised technique (Chapter 4) to assay for SN activity, the low number of cells (with respect to leucocytes/well) required for this assay method would keep to a minimum the required sorting time, and thus might lessen the likelihood of cell death through excessive handling.

The McAbs 8E4:57 and 8E4:13.3 are specific for *Xenopus laevis* IgM (Langeberg *et al*, 1987). The use of 8E4:57 and 8E4:13.3 hybridoma cell supernatants to label B cells in control and Tx *Xenopus* and to probe the nature of cells responding to ASNs is demonstrated in this Chapter. It was decided that Tx animals would be used to provide the source of B cells for investigating the nature of the cells that respond to ASNs. Tx *Xenopus* possess a greater proportion of sIgM<sup>+</sup> splenic leucocytes than control animals (Weiss, Horton & Du Pasquier, 1973; Nagata & Katagiri, 1978; Bleicher & Cohen, 1981). Furthermore, Weiss *et al* (1973) suggested that sIgM<sup>+</sup>



leucocytes from 7 day Tx *Xenopus* may possess more sIgM per cell than control sIgM<sup>+</sup> leucocytes, but whether this relates to a particular state of activation of such B cells has not, to my knowledge, been investigated. Tx animals appear to possess B cells with normal B cell functions; for example, they respond to B cell mitogens such as protein derivative of tuberculin (PPD) (Manning, Donnelly & Cohen, 1976) and pokeweed mitogen (PWM) (Schwager & Hadji-Azimi, 1984). The mammalian B cell mitogen lipopolysaccharide (LPS), in its purest form, is not mitogenic for *Xenopus* B cells at concentrations mitogenic for mammalian B cells (Bleicher *et al*, 1983). However, it was shown that a commercial preparation of LPS could induce the expression of cytoplasmic IgM<sup>+</sup> B lymphoblasts in cultures of *Xenopus* leucocytes (Williams *et al*, 1983; Hsu & Leanderson, unpublished) and that this mitogen can stimulate proliferation of B cells from Tx animals (Manning, Donnelly & Cohen, 1976).

To gain insight as to the nature of the mitotic factors present in the ASNs, initial attempts were made in this Chapter to begin to "concentrate" Con A-ASNs, through ammonium sulphate precipitation.

## 5.2 MATERIALS AND METHODS

### 5.2.1 Animals and thymectomy operation

LG15, LG5 and LM3 clones, together with *X.laevis* and

*X.borealis* were used. Some *X.laevis*, siblings to the controls studied, were thymectomised as detailed in section 3.2.1. Thymectomy was performed at 5.5 or 6.5 days of larval life.

#### 5.2.2 Culture of mouse hybridoma cells

Mouse hybridoma cell lines, 8E4:57 and 8E4:13.3, were a generous gift from Dr R.H. Clothier, Nottingham University. These hybridomas secrete anti-*Xenopus* IgM antibody.

The hybridoma cells were cultured in Dulbecco's modified Eagles medium (50ml DMEM (10 times normal strength); Gibco) diluted with 370ml sterile double distilled water, supplemented with 10ml L-glutamine (200mM), 5mls non-essential amino acids (100 times normal strength), 10ml sodium pyruvate (100mM), 25ml sodium bicarbonate (7.5%), 1% penicillin, 1% streptomycin, 1% fungizone (v/v), 10% FCS (all from Flow Labs) and 100 $\mu$ l 2-mercaptoethanol (50mM; BDH). The medium was filtered through 0.2 $\mu$ m filters (Flowpore).

Hybridoma cells were grown in 10ml or 25ml volumes in tissue culture flasks (Falcon) and cultured at 37  $\pm$  1°C and in 5% CO<sub>2</sub>. Hybridomas were seeded at about 1 x 10<sup>5</sup> cells/ml. They were re-seeded when they had reached a density of 1 x 10<sup>6</sup> cells/ml (approx. 3 days), in order to maintain the cells in logarithmic growth. Morphology of the hybridoma cells is shown in Fig. 5.1.

#### Storage of hybridoma cells by freezing

Hybridoma cells that were surplus to requirement were frozen using the following protocol. Cells were frozen down when they were in logarithmic growth. 10mls hybridoma suspension (i.e. culture SNs plus cells (approx.  $10 \times 10^6$ )) was spun down in 10ml centrifuge tubes (Sterilin) at 300g at 4°C for 10mins. The culture SN was discarded and the hybridoma cells were resuspended in 200 $\mu$ l of freezing mixture (8% DMSO (dimethyl sulfoxide; (Sigma) in FCS (Gibco)). The freezing mixture containing the cells was put into 1ml cryovials (Nunc). The vials were placed upright in a polystyrene box, surrounded with cotton-wool, and put in a -80°C freezer overnight. The vials were then transferred to racks and stored in liquid nitrogen.

#### Recovery of frozen hybridoma cells

Hybridoma cells could be successfully recovered after 2 months in liquid nitrogen (a longer freezing time was not undertaken). Cryovials recovered from liquid nitrogen were swabbed with alcohol. 300 $\mu$ l of DMEM (previously warmed to 37°C), supplemented with 20% FCS, was added to the vial containing the frozen hybridoma cells. The cells were transferred to a small sterile petri dish (Costar) containing 2ml DMEM (20% FCS). The hybridomas were cultured overnight at  $37 \pm 1^\circ\text{C}$  and in 5% CO<sub>2</sub>. The next day the hybridomas were transferred to a 10ml volume in a 25ml flask and cultured in the usual manner (see above).

### 5.2.3 Production of hybridoma culture supernatants

For the production of hybridoma culture SNs rich in secreted McAbs, hybridoma cells were cultured for 4 - 5 days (past the point of logarithmic growth). The contents of the tissue culture flasks were transferred to large 10ml or 25ml centrifuge tubes (Sterilin), depending on the volume of collected culture medium. The tubes were spun at 300g at 4°C for 10 mins to pellet the hybridoma cells, which were discarded. The culture SN was collected and stored at -20°C. 0.04%<sup>v/v</sup> sodium azide (BDH), an anti-bacterial agent, was added to the culture SNs, unless the SN was to be used to label cells that were to be cultured further.

### 5.2.4 Fluorescent microscopic studies on leucocytes stained with the monoclonal antibodies XT-1, 8E4:57 and

8E4:13.3

The medium used for the staining of the leucocytes was amphibian phosphate buffered saline (APBS; see appendix) supplemented with 0.1%<sup>v/v</sup> sodium azide (BDH) and 0.1%<sup>w/v</sup> BSA (Sigma). This medium was adjusted to pH 7.2 - 7.4.

Splenocytes and/or thymocytes suspensions were prepared from the spleen or thymus by dissociating the organ using sterile watchmakers forceps and iridectomy scissors; this provided a gentler way of preparing the

leucocytes than grinding the organs between glass slides. This method was used so that the cell preparation would contain only a minimum of cell debris (this may interfere with the counting procedure whether performed by eye or by FACS). The washing procedure was the same as detailed in section 2.2.3. The staining procedure was carried out on ice.

Splenocytes or thymocyte suspensions were adjusted to  $1 \times 10^6$  leucocytes/ml. 1ml aliquots were dispensed into the required number of experimental sample tubes. The leucocytes were centrifuged at 300g at 4°C for 10 mins. The medium was removed and 400 $\mu$ l of the primary antibody (i.e. XT-1, 8E4:57 or 8E4:13.3) was added. Leucocytes were stained with a 1/100 dilution of XT-1 ascites (generated by intraperitoneal injection of XT-1 hybridoma cells into pristane-primed Balb/c mice and subsequent removal of peritoneal fluid, which is extremely rich in antibody) in APBS or a 1/3 dilution of 8E4:57/13.3 culture SN (much less rich in antibody compared with ascites fluid) in APBS. Leucocytes were incubated with the primary antibody for 45 mins. They were then washed twice in 2ml cold APBS and incubated with a 1/30 dilution (500 $\mu$ l) of secondary antibody. This was a FITC-labelled, polyclonal anti-mouse IgG (Fab)<sub>2</sub> fragment (Dakopats). [A (Fab)<sub>2</sub> fragment was used to prevent non-specific binding by the Fc region of the FITC-labelled antibody.] The mouse (primary antibodies) McAbs used here have previously been shown all to be mouse IgG isotype. Leucocytes were incubated for 45 mins

with the secondary antibody. Control stainings involved incubation with secondary antibody only. The leucocytes were washed twice in 2ml APBS and, following the last centrifugation, were resuspended in 25 $\mu$ l of medium.

Approximately 10 $\mu$ l of stained cell suspension was placed on a clean glass slide, and a coverslip applied. Leucocytes were viewed using either phase contrast or incident light fluorescence. The microscope was a Nikon Optiphot, fitted with epifluorescence illumination and a FITC-filter set. Photographs were taken on the attached Nikon Microflex UFX-II camera.

At least 400 leucocytes were counted in each experimental sample. However, in the case of XT-1 staining of thymocytes, where the majority of leucocytes stained positive, counting of leucocytes proceeded until 200 XT-1+ leucocytes had been recorded.

In experiments where the percentage of positively labelled leucocytes from Tx and control *Xenopus* were compared, the observer did not know which of the animals' splenocytes were being counted. This was to avoid unintentional bias in the counting procedure.

#### 5.2.5 Flow cytometric analysis of leucocytes stained with anti-IgM monoclonal antibodies

Splenocytes from control and Tx animals were labelled with the primary anti-IgM antibody (8E4:57 or 8E4:13.3) and the secondary, FITC-conjugated antibody as detailed in section 5.2.6. Leucocytes were adjusted to a

concentration of  $1 \times 10^6$  leucocytes/ml in APBS. Control leucocytes consisted of  $1 \times 10^6$  leucocytes that had been incubated with secondary FITC-labelled antibody only. An additional control of  $1 \times 10^6$  leucocytes that had been kept in APBS only was also analysed.

There is usually about 3% non-specific staining of cells in a stained population; to eliminate the inclusion of non-specifically stained cells in the statistics ~~the second~~ cursor (on the FL 1 axis of Figs.) was set so that all cells (in reality the FACS counts "particles") that fell to the right of this cursor were counted as specifically stained (i.e. the cursor was set so that approximately 3% cells fell to the left of the cursor). In addition, gates were set so that very small particles (dead or dying leucocytes) and very large particles (the majority of erythrocytes) were excluded from the statistical analysis. The leucocytes were analysed on a FACS 420 (Becton Dickenson), in the Department of Surgery, University of Newcastle. 10 000 "particles" per sample were analysed. Analysis of data was performed on a BDIS Consort 30 programme.

#### 5.2.6 Protocol for leucocyte sorting using the FACS and subsequent culture of sorted cells

When leucocyte populations had to remain viable following cell sorting, for subsequent cell culture to monitor their responsiveness to ASNs, sodium azide was omitted from both the medium used for staining and the

culture SNs containing the McAb under study. In these cell sorting experiments, splenocytes from 6 - 8 month old *X.laevis*, previously Tx at 5.5 or 6.5 days of larval life, were used. Ideally, the sorting experiments should have been performed using splenocytes from clonal animals that had been larvally Tx. However, Tx clonal *Xenopus* were unavailable and consequently a pool of splenocytes from Tx wild *X.laevis* siblings (that do not show allo-MLC reactions) were used.

a) Preparation of Splenocytes

Splenocyte suspensions were prepared (for subsequent antibody staining and cell sorting) the day before. This was because sterile sorting facilities on the FACS in Newcastle were only available in a morning, from 09.00 hours; thus, preparing the cell suspensions would save time on the morning of the staining. A splenocyte suspension in AL-15:BSA was made, by teasing apart the spleen using forceps. The splenocyte suspension was layered onto Histopaque (density 1.077g/ml; Sigma) and spun in a centrifuge at 250g for 4 mins (at 4°C) to remove erythrocytes. Since FACS machines count and assess all the cells present (including red blood cells) when in sorting mode, removing the RBCs would shorten the sorting time necessary to collect enough leucocytes for culture in the SN proliferative assay. Splenocytes in AL-15:BSA were washed twice and cultured overnight (at  $3-4 \times 10^6$  leucocytes/ml) in 24-well plates (Cell Cult; Sterilin) at  $26 \pm 1^\circ\text{C}$  and in 5%  $\text{CO}_2$ .



b) Staining of splenocytes for FACS separation

The medium used for staining the splenocytes was APBS with 0.1% BSA, and at a pH of 7.2 - 7.4. The procedure was carried out on ice.

After overnight culture, early next morning, splenocytes were washed and viable splenocytes counted by their ability to exclude trypan blue; cell viability was >98%. Culture SN, from 8E4:57 hybridomas, containing anti-*Xenopus laevis* IgM was added at a dilution of 1/3 (200 $\mu$ l of primary antibody per  $1 \times 10^6$  viable leucocytes). Splenocytes were incubated in the diluted primary antibody for 45 mins and then washed twice by centrifugation at 300g for 10 mins at 4°C. 200 $\mu$ l secondary antibody (FITC-labelled anti-mouse IgG (Fab)<sub>2</sub> fragment; Dakopats) at 1/30 was added to  $1 \times 10^6$  splenocytes which were then incubated for 45 mins. Splenocytes were again washed twice then adjusted to  $2 \times 10^6$  leucocytes/ml. Cells were then transported, in ice, to the Dept. of Surgery in Newcastle.

c) Sorting of fluorescent-antibody labelled splenocytes  
by FACS

The fluorescence limits on the FACS were set conservatively to collect only strongly-fluorescing splenocytes (IgM<sup>+</sup>) and those splenocytes which showed no sign of fluorescence (IgM<sup>-</sup>). The splenocytes that fell between the two limits (i.e. weakly fluorescing leucocytes) were discarded. During the sorting procedure

splenocytes were collected into 5ml tubes (Falcon) with 1ml of ice-cold AL-15:FCS(20%) in the bottom to protect the cells during handling. After the sorting procedure, a small number of leucocytes were removed and treated with propidium iodide (Fluka), this labels dead cells within a population, which can then be counted on the FACS to give the percentage of viable cells (for these experiments cell death did not exceed 5%).

#### 5.2.7 Miniaturised supernatant assay for FACS-sorted splenocytes

On return to the cell culture laboratory in Durham, splenocytes were washed and their viability again estimated, using trypan blue dye exclusion (around 95% of leucocytes were viable). Splenocytes were adjusted to  $1 \times 10^6$  viable leucocytes/ml in AL-15:FCS(1%).  $15\mu\text{l}$  aliquots ( $1.5 \times 10^4$  leucocytes) were dispensed into wells of Terasaki plates (Nunc).  $5\mu\text{l}$  SN (or PHA solution) was added to produce a final "in well" concentration of 25% SN in a volume of  $20\mu\text{l}$ . Cultures were set up in replicates of 5. The Terasaki plates were inverted and splenocytes were cultured at  $26 \pm 1^\circ\text{C}$  in 5%  $\text{CO}_2$  and in 100% humidity.

After 48 hours, each well was pulsed with  $0.2\mu\text{Ci}$  [ $^3\text{H}$ ]TdR and harvested 20hr later, before analysis on a scintillation counter (see Chapter 4 for details of harvesting). Unsorted (not labelled), sIgM<sup>-</sup> and sIgM<sup>+</sup> leucocytes from the same initial population were

examined.

#### 5.2.8 Protein "concentration" procedures

##### Protocol 1

A Con A-ASN (24hrs) from a culture of *X.borealis* splenocytes (at  $5 \times 10^6$  leucocytes/ml), that had previously been shown to possess activity, was used in this purification procedure.

Solid ammonium sulphate (SAS) was added up to 50% and then 75% saturation to the SN (15ml starting volume), following the method of Watkins (1985). The correct weight of SAS to produce the required saturations were calculated from Dixon's nomogram (Dixon, 1953). This table allows the amount of SAS (in g/l) to be calculated for any SAS saturation percentage to the next required percentage SAS saturation.

SAS was added very slowly to the ASN, with continuous gentle stirring, until 50% saturation (312g/l) was reached. The solution was stirred for 2 hours at room temperature before it was centrifuged at 18000g for 20 mins at 4°C. The SN was removed, and the precipitate was dissolved in 1ml of double distilled water (fraction A). The remaining solution had SAS added until 75% saturation had been reached (an additional 172g/l). The solution was centrifuged at 18,000g for 20 mins at 4°C. A larger amount of precipitate was formed at this concentration. The SN was removed and the

precipitate was dissolved in 1ml double distilled water (fraction B).

Fraction A and B were dialysed using benzoylated tubing with a molecular cut off of 2500 (Sigma). The fractions were dialysed against 1l of APBS overnight at 4°C. This dialysis procedure was repeated twice more. The dialysed fractions were finally filtered (0.2µm; Millipore) and frozen in cryovials (Nunc).

The fractions were tested in the standard proliferative assay for SN activity, using *X.laevis* splenocytes precultured for 5 days with or without PHA-P. A range of dilutions of A and B were assayed on the leucocytes.

#### Protocol 2

A Con A-ASN (24 hrs) from a culture of LG15 splenocytes was used here. In this purification protocol, three SAS cuts were made at 50% (fraction A), 65% (fraction B) and 85% (fraction C). The remaining SN was also assayed (fraction D).

SAS was added very slowly to the ASN, with continuous gentle stirring, until 50% saturation (312g/l) was reached. The solution was stirred for 1 hour at room temperature before it was centrifuged at 18000g for 20 mins at 4°C. The SN was removed, and the precipitate was dissolved in 2.5mls of double distilled water (fraction A). The remaining solution had SAS added until a concentration of 65% had been reached (an additional 98g/l). The solution was centrifuged at 18 000g for 20

mins at 4°C. The SN was removed and the precipitate was dissolved in 2.5ml double distilled water (fraction B). Finally, the remaining solution had SAS added until 80% saturation had been reached (additional 100g/l). This solution was centrifuged at 18 000g for 20 mins at 4°C. The SN was removed and the (large amount of) precipitate was dissolved in 2.5ml double distilled water (fraction C). The remaining solution was also kept (fraction D).

In this second protocol, A, B, C and D were desalted using a PD10 column (Pharmacia). This is a <sup>prepacked</sup> gel filtration column that removes low molecular weight (<12 kD) compounds from a sample. The column was equilibrated with 2.5 column volumes of APBS. 2.5ml of fraction A was applied to the top of the column. When this had run into the column 3.5ml APBS were applied to the top of the column. The resulting eluent (containing all proteins >12000kD) was collected from the bottom of the column and was filtered (0.2µm; Millipore) and frozen in cryovials. This procedure was repeated for fractions B, C and D.

The fractions were tested in the standard proliferative assay for SN activity, using *X.laevis* splenocytes precultured for 5 days with or without PHA-P. A range of dilutions of A, B, C & D were assayed on the leucocytes.

## 5.3 RESULTS

### 5.3.3 Initial characterisation of anti-IgM and anti-T cell monoclonal antibodies by fluorescence microscopy

#### 5.3.1.1 Studies on splenic lymphocytes prior to and following PHA stimulation

This experiment was performed to gain practical experience of using the McAbs and in order to determine if proportions of B cells (IgM<sup>+</sup>) and T cells (XT-1<sup>+</sup>) changed with preculture in medium with and without PHA.

Incubation with XT-1 primary antibody and subsequent FITC-labelled secondary antibody revealed that in 3 experiments (in separate animals) an average of  $18 \pm 4.4\%$  LM3 splenocytes (stained directly after removal from the animal) stained positively. Incubation of the same cells with the anti-IgM McAb plus fluorescent probe showed an average of  $32.8 \pm 12\%$  of LM3 splenocytes expressed surface IgM (sIgM).

LM3-splenocytes that had been cultured for 5 days in AL-15:FCS(5%) medium alone contained an average of  $27.7 \pm 9.6\%$  sIgM<sup>+</sup> cells. In contrast, there was a lower mean proportion ( $15 \pm 9.8\%$ ) of sIgM<sup>+</sup> cells in the LM3 population cultured with PHA (Table 5.1). Thus, culturing splenocytes with PHA reduced the proportion of sIgM<sup>+</sup> spleen cells, presumably due to an increase in T cell numbers. Unfortunately, this was not tested experimentally, as a preliminary experiment had shown

that judging the XT-1 staining in spleen cell populations (that had been cultured) was too difficult to be done confidently by eye, because of the amount of cell debris.

#### 5.3.1.2 Studies of splenocytes and thymocytes stained with the McAbs 8E4:57, 8E4:13.3 or XT-1

This experiment was performed in order to gain insight into the proportions of sIgM<sup>+</sup> cells (B cells) and XT-1<sup>+</sup> cells (T cells) present in the spleen and thymus of the population of *X.laevis* animals that were to be used for subsequent staining experiments.

*X.laevis* splenocytes that were labelled with the anti-IgM McAbs 8E4:57 and 8E4:13.3 showed similar staining patterns (17.7 ± 3.2% and 22 ± 2.5% sIgM<sup>+</sup> leucocytes, respectively; Table 5.2). There were very few (<3%) sIgM<sup>+</sup> cells in the thymocyte cell suspensions.

In one experiment on *X.laevis* splenocytes, 16% cells were labelled with the anti-T cell McAb, XT-1. In two thymocyte preparations studied, over 95% cells were XT-1<sup>+</sup> (Table 5.2).

#### 5.3.1.3 Comparison of splenocytes from control and thymectomised *Xenopus laevis*, stained with anti-IgM antibody (8E4:57)

This experiment was performed to compare the proportion of IgM<sup>+</sup> splenocytes in Tx *Xenopus* with that of their sibling controls. It was demonstrated that *Xenopus laevis* Tx at 6.5 days of larval life possessed a higher proportion of leucocytes expressing sIgM (56 ± 10%) than

their sibling controls ( $36 \pm 5\%$ ) as measured by FITC-labelled antibody staining using 8E4:57 primary antibody (Table 5.3)

### 5.3.2 Flow cytometric analyses of leucocytes stained with anti-IgM antibodies: Comparison of splenocytes from control and thymectomised *X.laevis*

FACS analysis of sIgM<sup>+</sup> splenocytes from control and Tx *X.laevis* revealed that Tx animals (Tx at 6.5 days) possessed a higher proportion of sIgM<sup>+</sup> leucocytes. A Tx *Xenopus* had 63.9% sIgM<sup>+</sup> cells when the primary antibody used was 8E4:57, and 65.8% sIgM<sup>+</sup> when the cells from the same population were stained using 8E4:13.3. In contrast, its control possessed 21.6% sIgM<sup>+</sup> cells (when 8E4:57 was used) and 26.9% sIgM<sup>+</sup> cells (when 8E4:13.3 was used). In another experiment Tx and control animals possessed 44.5% and 19.9% sIgM<sup>+</sup> respectively when labelled using 8E4:13.3 (Table 5.4, Fig. 5.2).

Control splenocytes incubated with secondary antibody only, showed negligible fluorescence when analysed by FACS (Fig. 5.2).

IgM-staining of splenocyte suspensions from a further five *X.laevis*, that had been Tx at 5.5 or 6.5 days of age, were assessed by flow cytometry. In contrast to the above, these cells had initially been incubated overnight after centrifugation over Histopaque (to remove RBCs), since these cells were to be sorted on the FACS in



Newcastle, which required cell suspension preparation in advance. These Tx animals possessed an average  $51 \pm 6.6\%$  sIgM<sup>+</sup> cells compared with an average of  $21.4 \pm 2.1\%$  from their controls.

Comparison of the dot plots from control and Tx *Xenopus* (Fig. 5.3) shows a similar 'scatter' of the two populations.

### 5.3.3 Effect of PHA-P, PHA-P-SNs and MLC-SNs on unsorted and on sIgM<sup>+</sup> and sIgM<sup>-</sup> sorted splenocytes from thymectomised *Xenopus*

Splenocytes from Tx animals were sorted into sIgM<sup>+</sup> and sIgM<sup>-</sup> populations after a labelling procedure with the anti-IgM McAb 8E4:57 (Fig. 5.4). Some splenocytes remained unsorted to act as controls.

Contour dot plots, which plot forward light scatter (FSC) - a measure of cell size, against granularity (RTO) - an indication of cell density, revealed that the sIgM<sup>+</sup> population contained a relatively homogeneous population of leucocytes (dots, each one representing a cell) were concentrated in the same area of the plot; Fig. 5.5) whilst the sIgM<sup>-</sup> population was more heterogeneous (dots scattered over a larger area of the plot; Fig. 5.5).

The unsorted, sIgM<sup>+</sup> and sIgM<sup>-</sup> splenocyte populations from Tx *X.laevis* were tested for their ability to proliferate when cultured with PHA-P or various ASNs. Unsorted splenocytes from 5.5 day Tx *Xenopus* were, in this experiment, stimulated by an optimal PHA-P dose (SI = 6.3; Table 5.5). Unsorted splenocytes also showed

enhanced thymidine incorporation when cultured with T cell mitogen-induced or MLC-induced ASNs. One of the MLC-ASNs (from a two-way MLC) seemed particularly potent, causing the unsorted cells to proliferate 11-fold (admittedly the CSNs produced very low counts, which may exaggerate the SI recorded).

The splenocytes that had stained positively when labelled with the anti-IgM McAb, 8E4:57 (sIgM<sup>+</sup>) showed no induced uptake of [<sup>3</sup>H]TdR when stimulated by PHA-P. However, this same population of cells, when cultured with PHA-P-ASN, displayed a low level of induced proliferation, which was significantly different than the medium controls (p < 0.001). Culture of the sIgM<sup>+</sup> splenocytes with MLC-ASNs responded by a small, but significant (p = 0.01) proliferation when cultured with the two-way MLC-ASN. However, the one-way MLC-ASN did not achieve a significant proliferative response from the sIgM<sup>+</sup> splenocytes.

The sIgM<sup>-</sup> population was able to display proliferative responses to the PHA-P-ASNs (SI = 7.0) and both MLC-ASNs (SIs = 13.7 and 12.7, for the two-way and one-way MLC-ASNs, respectively). There were not enough cells to check the response of sIgM<sup>-</sup> cells to PHA-P. However, in another experiment, such cells responded 5-fold to optimal doses of this mitogen.

#### 5.3.4 Attempts to "concentrate" Con A-SNs

Attempts to purify Con A-ASNs were unsuccessful (see Discussion). None of the fractions retained activity in

the SN assays.

FIG. 5.1

Hybridoma cells that secrete McAbs 8E4:57 or 8E4:13.3 are pictured here (under Nomarski transmission).

A) shows large and small hybridoma cells.

B) shows a large cell in mitosis (the chromosomes lining up on the spindle can be distinguished).

— = 15  $\mu$ m

A

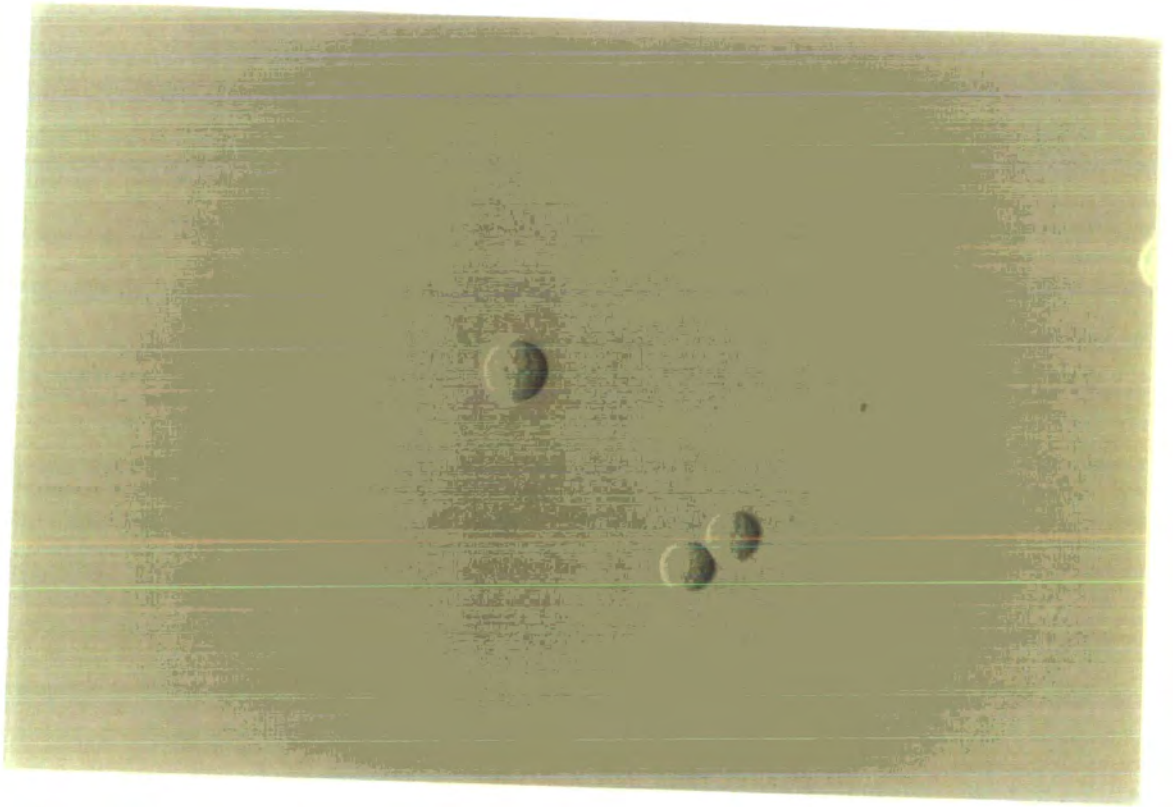

B

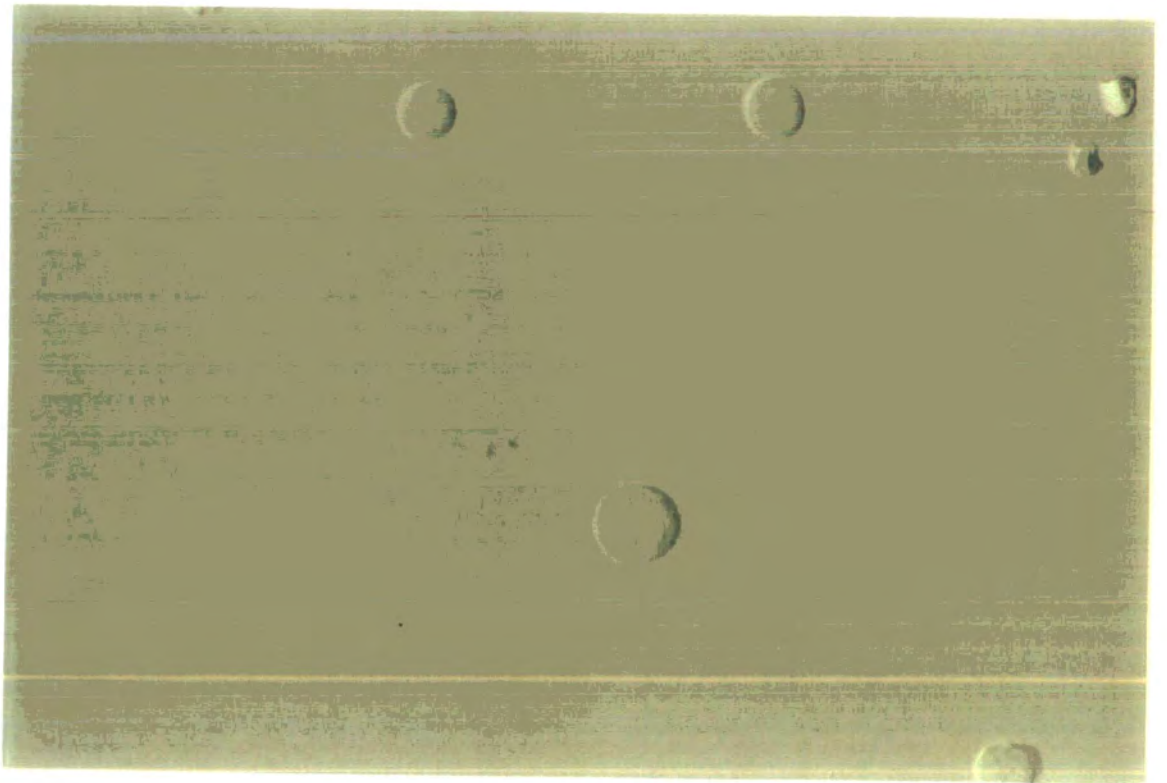

FIG. 5.2

Splenocytes from control and Tx *X.laevis* were labelled with the anti-IgM McAb 8E4:57, and then incubated with the FITC-labelled secondary antibody. As a control, a proportion of both populations was incubated with secondary antibody alone.

For FACS analysis the majority of XRBCs were gated out of the analysis by setting size limits (*Xenopus* RBCs are much larger than leucocytes). 10, 000 splenocytes were counted per experimental sample.

Figs. with one vertical marker show the 2-3% background staining (to the right of the marker). Figs with two vertical markers denote the proportion of splenocytes that stain brighter than control stainings (between 1st and 2nd marker) and the proportion of splenocytes that stain very brightly (between 2nd and end marker).

x = fluorescence intensity (log scale).

y = proportion of cells labelled.

N.B. In Tables the proportion of cells that fall to the right of the first marker are scored as positive (e.g. see Table 5.4). These proportions are calculated by the computer directly.

FIG. 5.2 FACS PROFILES OF SPLENCYTES FROM CONTROL AND THYMECTOMISED *XENOPUS LAEVIS* LABELLED WITH ANTI-IgM ANTIBODY

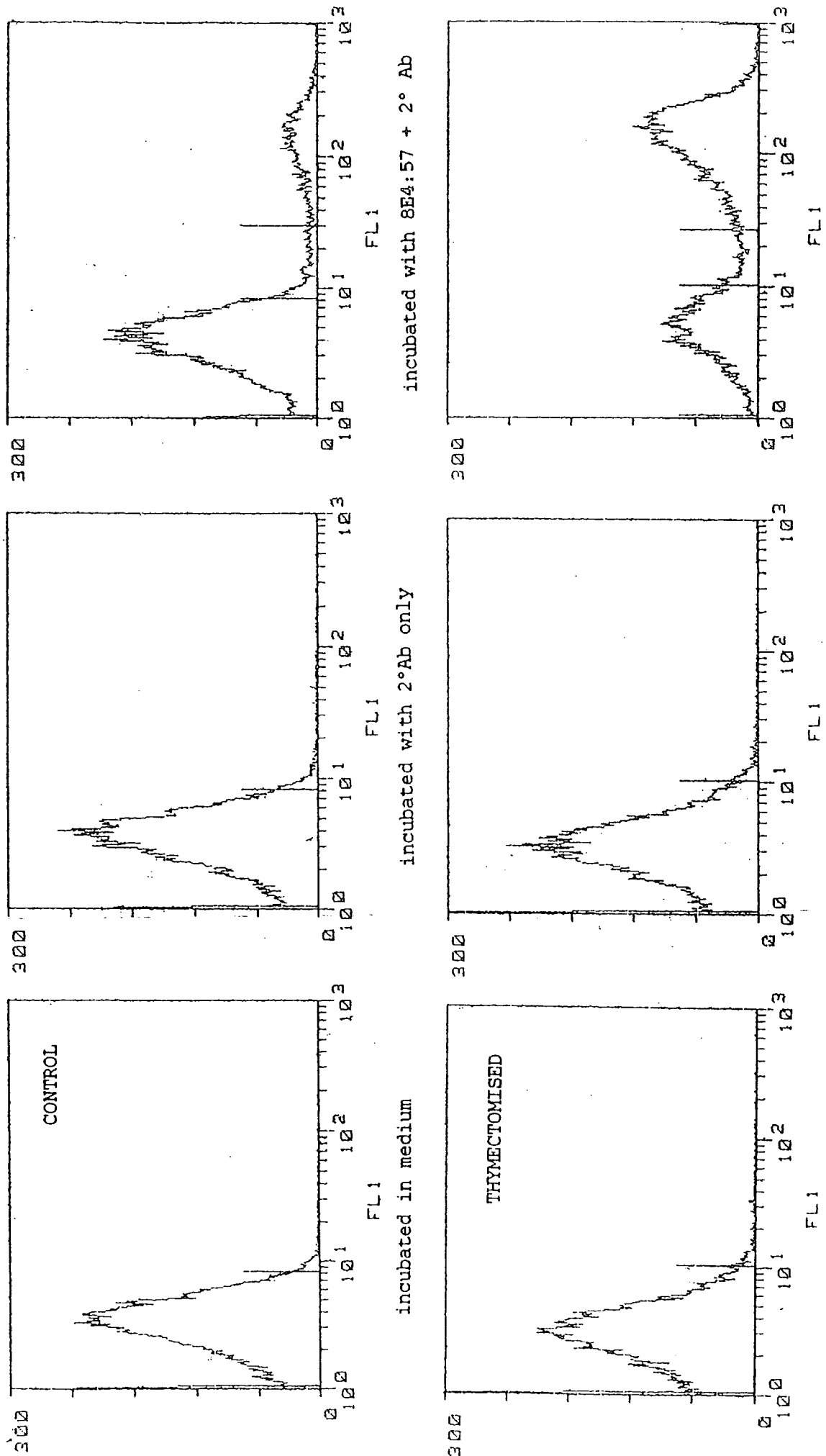

FIG. 5.3

A and B are the FACS "dot plots" of splenocytes from control (A) and Tx (B) *X.laervis* siblings. Each dot represents a cell/particle (10 000 dots).

x = RTO (granularity), this is an indication of density of the analysed cells.

y = FSC (forward scatter), this is an indication of the size of the analysed cells.



FIG. 5.3 DOT PLOTS OF CONTROL AND THYMECTOMISED

XENOPUS LAEVIS SIBLINGS

A) CONTROL

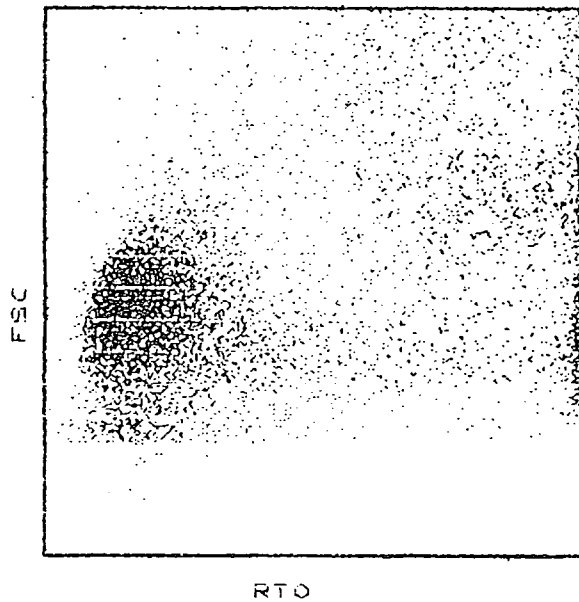

B) THYMECTOMISED

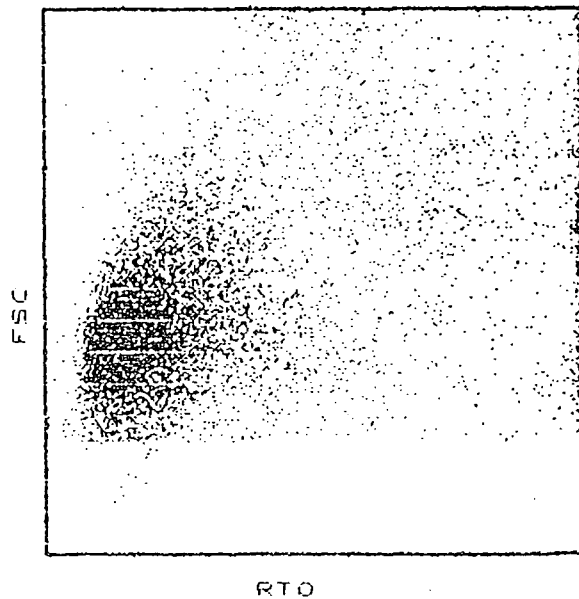

FIG. 5.4

Splenocytes from Tx *X.laevis*, were labelled with the anti-IgM McAb 8E4:57, and then incubated with the FITC-labelled secondary antibody, before being sorted and analysed by FACS. 10 000 cells per sample were analysed (except (B), where 5000 cells were analysed).

x = fluorescence intensity (log scale).

y = proportion of cells labelled.

A) = the fluorescence profile of the IgM<sup>-</sup> population

B) = the fluorescence profile of the IgM<sup>+</sup> population

C) = the fluorescence profile of the unsorted population.

D) = a composite diagram of the above three diagrams (with 10 000 cells analysed for all three populations.

The vertical marker is in the same position on A, B and C.

Cells with the profiles A-C are those whose proliferative functions are studied in Table 5.3.

FIG. 5.4 FACS PROFILES OF FACS SORTED SPLENOCYTE

POPULATIONS FROM THYMECTOMISED *XENOPUS LAEVIS*

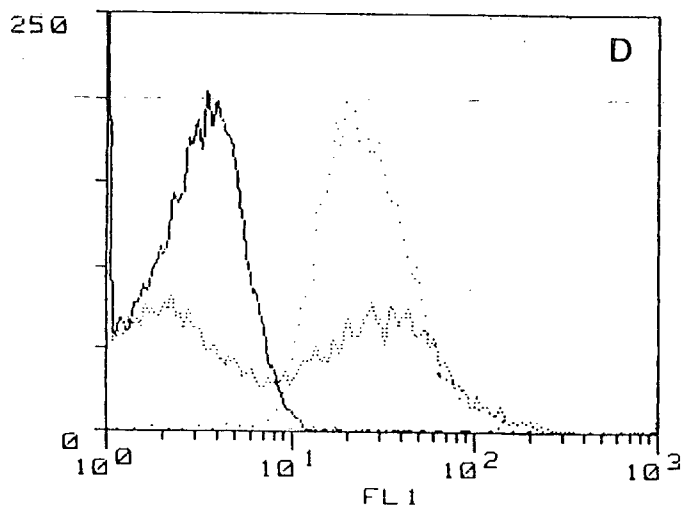
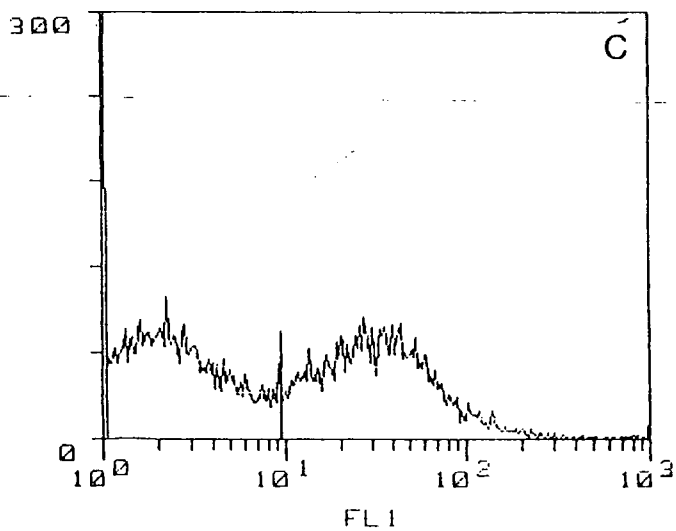
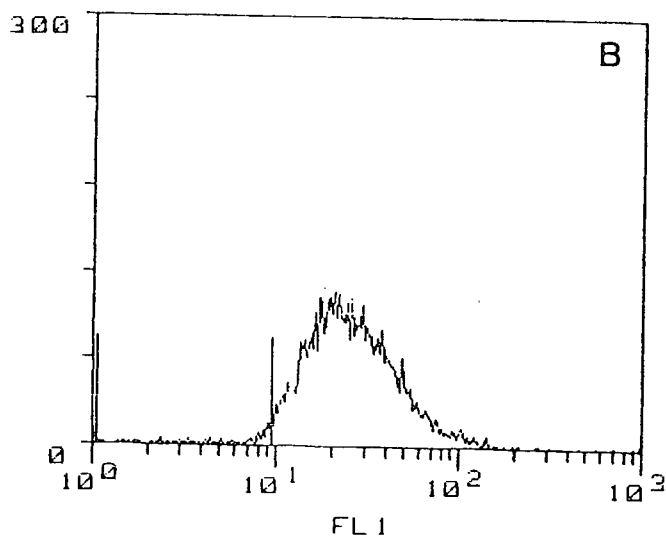
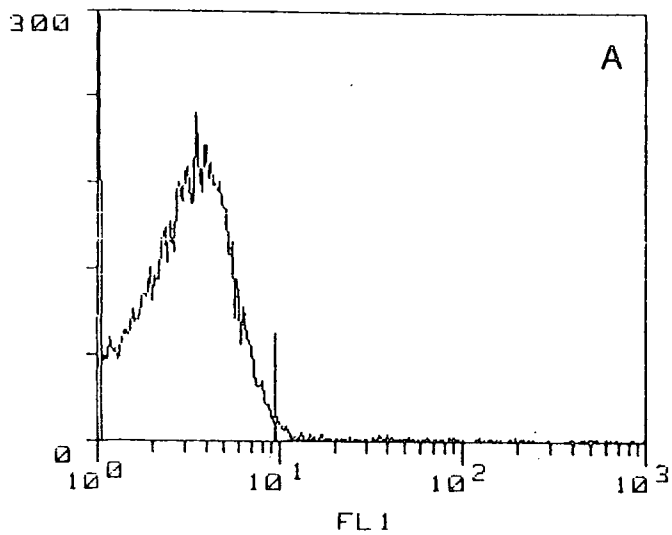

FIG. 5.5

A, B and C are contour diagrams from a FACS analysis of splenocytes from Tx *X.laevis*, that were labelled with the anti-IgM McAb 8E4:57, and then incubated with the FITC-labelled secondary antibody, before being sorted by FACS. 10 000 cells per sample were analysed.

The innermost contour describes the area where the majority of analysed cells lie, the other contours describe areas where cells are less densely distributed, whilst the dots represent single cells. The rectangular box seen on the diagrams is the same size and in the same position on all three diagrams, and is there as a reference to compare plots.

A = unsorted splenocyte population.

B = "positive" splenocyte population (i.e. IgM<sup>+</sup>).

C = "negative" splenocyte population (i.e. IgM<sup>-</sup>).

x = RTO (granularity), this is an indication of density of the analysed cells.

y = FSC (forward scatter), this is an indication of the size of the analysed cells.

FIG. 5.5 CONTOUR PLOTS OF FACS SORTED SPLENOCYTE  
POPULATIONS FROM THYMECTOMISED XENOPUS LAEVIS

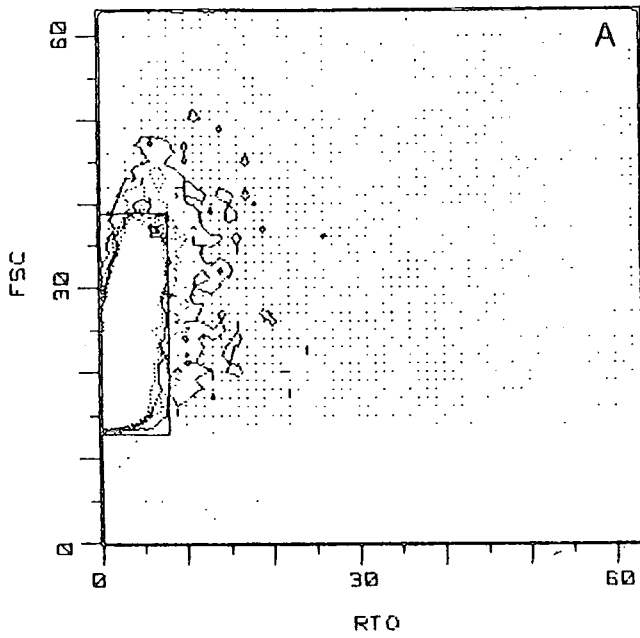

A) Complete (unsorted) pop<sup>n</sup>

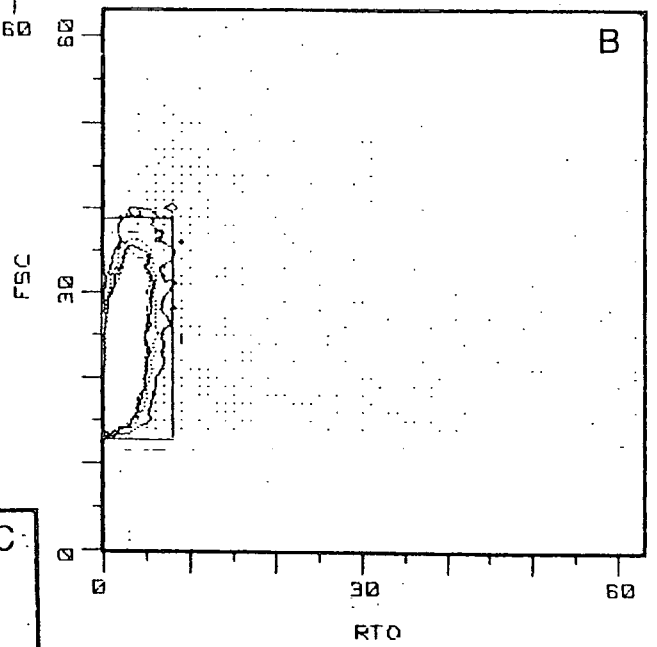

B) sIgM<sup>+</sup> pop<sup>n</sup>

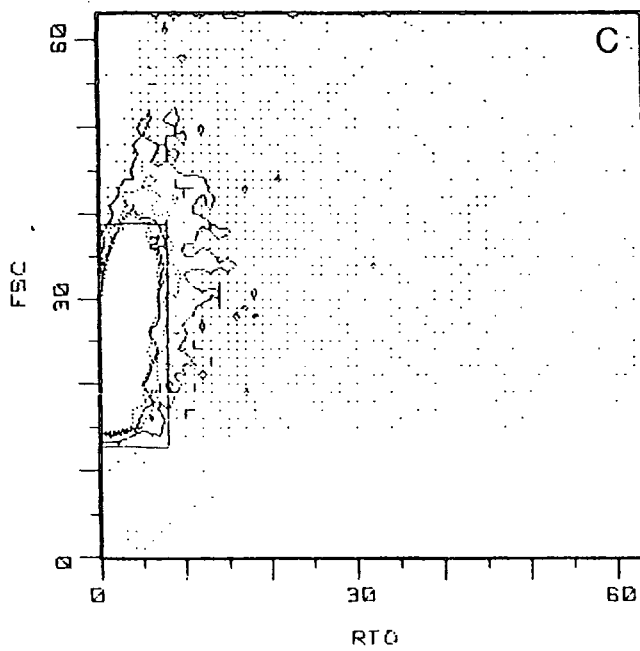

C) sIgM<sup>-</sup> pop<sup>n</sup>

TABLE 5.1

LM3 splenocytes examined directly after removal were incubated with 8E4:57 culture SN (dil. 1/4), or with XT-1 ascites (dil. 1/100). Leucocytes were subsequently incubated with FITC-labelled secondary antibody (dil. 1/30). Leucocytes were examined by fluorescence microscopy, and 500 leucocytes per sample were counted.

Splenocytes from the same population were cultured for 5 days in AL-15:FCS(5%) with or without PHA. After 5 days leucocytes were stained for sIgM using 8E4:57 and analysed as above.

The results from three animals are shown here.

TABLE 5.1 FLUORESCENT ANTIBODY STAINING OF LM3 SPLENOCYTES STAINED WITH  
McAbs 8E4:57 AND XT-1

| expt.<br>no.     | McAb<br>(used for<br>staining) | splenocyte treatment:   |                          |                         |
|------------------|--------------------------------|-------------------------|--------------------------|-------------------------|
|                  |                                | no preculture<br>no PHA | 5 day cultured<br>no PHA | 5 day cultured<br>+ PHA |
| % cells labelled |                                |                         |                          |                         |
| 1                | 8E4:57                         | 26.9                    | 20.9                     | 8.1                     |
|                  | XT-1                           | 20.6                    | n.d.                     | n.d.                    |
| 2                | 8E4:57                         | 46.5                    | 34.5                     | 20.1                    |
|                  | XT-1                           | 20.5                    | n.d.                     | n.d.                    |
| 3                | 8E4:57                         | 25.0                    | n.d.                     | n.d.                    |
|                  | XT-1                           | 13.0                    | n.d.                     | n.d.                    |

TABLE 5.2

*X.laevis* leucocytes were incubated with 8E4:57 or 8E4:13.3 culture SN (dil. 1/4), or with XT-1 ascites (dil. 1/100). Leucocytes were subsequently incubated with FITC-labelled secondary antibody (dil. 1/30).

In most cases, 500 leucocytes per sample were counted and scored as fluorescence-positive or negative. For XT-1 staining of thymocytes, only 200 cells were counted.

The results from three animals are shown here.



TABLE 5.2 FLUORESCENT ANTIBODY STAINING OF SPLENOCYTES AND THYMOCYTES  
FROM XENOPUS LAEVIS WITH ANTI-IgM McAbs AND XT-1

| expt. no.        | origin of leucocytes | 8E4:57 | 8E4:13.3 | XT-1 |
|------------------|----------------------|--------|----------|------|
| % cells labelled |                      |        |          |      |
| 1                | spleen               | 20.0   | 24.0     | n.d. |
|                  | thymus               | n.d.   | n.d.     | n.d. |
| 2                | spleen               | 14.0   | 19.0     | n.d. |
|                  | thymus               | 3.0    | 2.0      | 96.0 |
| 3                | spleen               | 19.0   | 22.0     | 16.0 |
|                  | thymus               | 3.0    | 2.5      | 97.0 |

TABLE 5.3

Splenocytes from control and Tx *X.laevis* were incubated with 8E4:57 culture SN (dil. 1/4), and subsequently incubated with FITC-labelled secondary antibody (dil. 1/30).

500 splenocytes were counted for each experimental sample. Splenocyte populations from control and Tx animals were coded so as to avoid bias when counting.

The results from 2 control and 2 Tx *X.laevis* are shown here.

TABLE 5.3 FLUORESCENT ANTIBODY LABELLING OF SPLENOCYTES FROM CONTROL  
AND THYMECTOMISED X.LAEVIS WITH ANTI-IgM

expt. no.                      *X. laevis*                      % cells labelled with 8E4:13.3

|   |         |      |
|---|---------|------|
| 1 | control | 32.0 |
|   | Tx      | 49.0 |
| 2 | control | 39.6 |
|   | Tx      | 62.0 |

TABLE 5.4

Splenocytes from control and Tx *X.laevis* were incubated with 8E4:57 or 8E4:13.3 culture SN (dil. 1/4), and subsequently incubated with FITC-labelled secondary antibody (dil. 1/30).

Splenocytes were analysed on a FACS. Each result is the percentage of fluorescent cells in a sample of 10,000 cells. The fluorescence profiles of the samples from expt. 2 (8E4:57 culture SN) are shown in Fig. 5.2.

The results from 2 control and 2 Tx *X.laevis* are shown here.

TABLE 5.4 FACS ANALYSIS OF FLUORESCENT ANTIBODY LABELLING FROM CONTROL  
AND THYMECTOMISED *X.LAEVIS* STAINED WITH ANTI-IQM McAbs

| expt.<br>no. | <i>X. laevis</i> | splenocytes incubated with: |                  |
|--------------|------------------|-----------------------------|------------------|
|              |                  | 8E4:57                      | 8E4:13.3         |
|              |                  |                             | % cells positive |
| 1            | control          | n.d.                        | 19.9             |
|              | Tx               | n.d.                        | 44.5             |
| 2            | control          | 21.6                        | 26.9             |
|              | Tx               | 63.9                        | 65.8             |

TABLE 5.5 EFFECT OF PHA-P, PHA-P SNS AND MLC-SNs ON THYMIDINE INCORPORATION  
IN UNSORTED, IgM+ AND IgM- SPLENOCYTES FROM  
THYMECTOMISED X.LAEVIS

assay cells cultured with:

| assay cell<br>population | medium (0.5µg/ml) |            |            |                     |           |          | mean dpm ± sem<br>[SI] |          |
|--------------------------|-------------------|------------|------------|---------------------|-----------|----------|------------------------|----------|
|                          | PHA-P             | PHA-P-CSN  | PHA-P-ASN  | MLC-CSN             | MLC-CSN   | MLC-CSN* | MLC-CSN                | MLC-ASN* |
| unsorted                 | 167 ± 54          | 1054 ± 137 | 253 ± 59   | 69 ± 6              | 75 ± 14   |          |                        |          |
|                          |                   |            | 1458 ± 70  | 81 ± 14             | 483 ± 134 |          |                        |          |
|                          |                   | [6.3]      | [5.8]      | 847 ± 96<br>[11.0]  |           | [6.4]    |                        |          |
| sIgM+                    | 87 ± 19           | 44 ± 5     | 110 ± 8    | 108 ± 10            | 48 ± 3    |          |                        |          |
|                          |                   |            | 375 ± 40   | 65 ± 9              | 66 ± 11   |          |                        |          |
|                          |                   | [0.5]      | [3.4]      | 166 ± 15<br>[1.9]   |           | [1.4]    |                        |          |
| sIgM-                    | 129 ± 35          | n.d.       | 196 ± 30   | 102 ± 17            | 86 ± 12   |          |                        |          |
|                          |                   |            | 1370 ± 135 | 114 ± 23            | 1094 ± 80 |          |                        |          |
|                          |                   |            | [7.0]      | 1482 ± 82<br>[13.7] |           | [12.7]   |                        |          |

MLC-CSN = LM3  
 MLC-CSN = wild  
 MLC-ASN = LM3 x wild  
 PHA-P-SNs = LG17  
 MLC-CSN\* = a pool of one-way MLC-CSNs  
 MLC-ASN\* = " " " " MLC-ASNs

TABLE 5.5

A splenocyte suspension from pooled Tx *X.laevis* (6-8 months of age) was separated over Ficoll to remove XRBC and cultured overnight ( $2-3 \times 10^6$  leucocytes/ml) in AL-15:BSA in 24-well flat-based plates. Splenocytes were then incubated with 8E4:57 culture SN (dil. 1/4), and subsequently incubated with FITC-labelled secondary antibody (dil. 1/30). Splenocytes were then sorted on a FACS. This produced an IgM<sup>+</sup> and IgM<sup>-</sup> populations, an unsorted cell population was also available as a control.

The unsorted, and both sorted splenocyte populations were plated out ( $1.5 \times 10^4$  leucocytes/well) in Terasaki plates in AL-15:FCS(1%). 5 $\mu$ l SN was added to bring the final "in well" SN concentration to 25% in a total volume of 20 $\mu$ l. Cultures were set up in replicates of 5. After 48 hours of culture, each well was pulsed with 0.2 $\mu$ Ci [<sup>3</sup>H]TdR and harvested 20 hours later.

Results shown are from one of two experiments (with similar outcome) carried out.

$$\text{SI (PHA)} = \frac{\text{PHA cultures (dpm)}}{\text{med. cultures (dpm)}}$$

$$\text{SI (PHA-SN)} = \frac{\text{ASN cultures (dpm)}}{\text{CSN cultures (dpm)}}$$

$$\text{SI (2-way MLC-SNs)} = \frac{\text{wild x LM3 ASN (dpm)}}{\text{wild x wild CSN/2 + LM3 x LM3 CSN/2 (dpm)}}$$

N.B. PHA-SN have been CRBC-passed to remove residual PHA-P

#### 5.4 DISCUSSION

The anti-*Xenopus* T cell McAb, XT-1, recognises the XTLA-1 antigen on the majority of *Xenopus* T cells (Nagata, 1985, 1988). In this Chapter, the XT-1 McAb (in conjunction with a secondary, fluorescent antibody) was used to label *Xenopus* leucocytes, this produced a similar staining pattern as had been previously reported (Nagata, 1988). That is, virtually all thymocytes ( $96.5 \pm 0.7\%$ ) and  $17.5 \pm 3.7\%$  of *Xenopus* splenocytes stained positively with XT-1.

The *Xenopus* anti-IgM McAbs, 8E4:57 and 8E4:13.3, were also used for fluorescence-labelling studies on *Xenopus* leucocytes. Thymocyte suspensions showed minimal staining with these antibodies, as has been observed with other anti-IgM McAbs (Flajnik *et al*, 1988; Bleicher & Cohen, 1981). Typically, about 20% of splenocytes in suspension were sIgM<sup>+</sup>. The effect of culture on the distribution of sIgM<sup>+</sup> leucocytes revealed that after 5 days in culture with PHA (the same conditions used to generate T cell blasts), the proportion of sIgM<sup>+</sup> leucocytes dropped considerably, indicating that the proportion of B cells was decreasing, probably due to the increase in the proportion of T cell blasts (though this latter point was not demonstrated).

Thymectomy at 5.5 and 6.5 days of larval life produced a dramatic increase in the proportion of sIgM<sup>+</sup> leucocytes, in agreement with other authors (Weiss,



Horton & Du Pasquier, 1973; Nagata & Katagiri, 1978; Bleicher & Cohen, 1981). In most cases, more than 50% of splenocytes from Tx animals stained positive with the anti-IgM McAbs, as analysed by fluorescence microscopic studies, or on a FACS. FACS analysis showed that the fluorescence intensity following anti-IgM staining was the same for splenocytes from both control and Tx animals. This indicates that a similar amount of sIgM molecules per cell are expressed on splenocytes from control and Tx animals. This is in contrast to earlier fluorescence microscopic studies (Weiss, Horton & Du Pasquier, 1973) which suggested that Tx *Xenopus* labelled with anti-Ig antibodies fluoresced more brightly than labelled splenocytes from control animals. Splenocytes from the 5.5 and 6.5 day-Tx animals showed a proliferative response when cultured with mitogen-derived ASN or MLC-derived ASN, as had splenocytes from *Xenopus* Tx at 7 days, as shown in previous experiments (Chapter 4). The T cell mitogen, PHA-P, also induced a proliferative response in leucocyte cultures of these 5.5 - 6.5 day Tx animals, although this is of a much lower order of magnitude compared with control cells (see Chapter 3). Previous studies on such parameters as alloimmune reactivity and PHA responsiveness have suggested that residual, "T-like" cells are present in such early-Tx *Xenopus* (Nagata & Cohen, 1983; Green, Donnelly & Cohen, 1979).

The *Xenopus laevis* Tx at 5.5 - 6.5 days of age were shown by FACS analysis not to possess XTLA-1 (Varley,

Ph.D thesis, 1990). These were the siblings of the animals used in the sIgM-labelling experiments presented here. Therefore, thymectomy at this stage had successfully removed the XTLA-1<sup>+</sup> population of T cells. Thus, splenocytes from Tx animals that were sorted by FACS [after incubation with anti-IgM McAb and FITC-labelled antibody] yielded a population of sIgM<sup>-</sup>(XTLA-1<sup>-</sup>) lymphocytes and sIgM<sup>+</sup> (XTLA-1<sup>-</sup>) B cells.

Mammalian B cells can be activated through the binding of anti-Ig antibodies to the B cell sIg, to become B blasts. This is also true of *Xenopus* B cells (Schwager & Hadji-Azimi, 1985). *Xenopus* B cells proliferate markedly, as measured by [<sup>3</sup>H]TdR incorporation, when cultured with anti-IgM antibodies. It has also been revealed elsewhere that B cells from Tx *Xenopus* animals responded by proliferation when cultured with anti-IgM antibodies (Schwager & Hadji-Azimi, 1985). In the labelling experiments presented here, it was possible that incubation with the anti-IgM McAb would therefore induce B cells to proliferate. This did not appear to be the case, however, since sIgM<sup>+</sup> splenocytes cultured in medium did not yield elevated [<sup>3</sup>H]TdR counts compared with the other cell populations. There are a number of possible explanations for this, the most likely being that these cells were identified using a double-labelling protocol, which may have interfered with the normal activation of B cells by the sIg-binding activation route.

The experiments reported here show that sIgM<sup>+</sup>

splenocytes (B cells) did not respond to PHA-P, suggesting that this population did not contain any mature, functional T-like cells. The sIgM<sup>+</sup> splenocytes (B cells) responded by proliferation to the PHA-P-ASNs and showed a slight but significant response to one of the MLC-ASNs. It is unclear as to whether these SNS were acting on resting B cells or B blasts, but clearly the PHA-P-ASN possessed a low level mitotic activity for B cells.

The sIgM<sup>-</sup> (XTLA-1<sup>-</sup>) splenocytes contained the population that could proliferate in response to PHA-P (suggesting the presence of "T-like" cells) and which showed a healthy response to all the SNS tested (PHA-ASNs, MLC-ASNs, one-way and two-way). In nude mice, functionally-mature T cells could be induced, when their leucocytes were cultured in IL-2 plus antigen (Gillis et al, 1979; Hünig & Bevan, 1980). In *Xenopus* also, PHA-responsive splenocytes were found in cultures of splenocytes from *Xenopus* Tx at 10 days of age, that had been cultured in PHA-ASNs with additional PHA (Cohen, Watkins & Parsons, 1987). However, in the experiments presented in this Chapter, the splenocytes from Tx (5.5 - 6.5 days) animals were able to respond to the PHA-ASNs and MLC-ASNs directly, without prior stimulation (e.g. culture with PHA). This suggests that the appropriate mitotic factor receptors may be constitutively expressed on the splenocyte cell surface, or may have been induced through *in vivo* or *in vitro* activation as described in previous chapters. It would be of interest to investigate

whether the sIgM<sup>-</sup> (XTLA-1<sup>-</sup>) (T-like?) cells become XTLA-1<sup>+</sup> after treatment with ASNs.

Watkins (1985) was able to show the appearance of a 15-25kD protein in PHA-ASNs from control, outbred *X.laevis*, by SDS-PAGE. However, an attempt was not made to elute activity from this band. Unfortunately, attempts to "concentrate" Con A-ASNs in this laboratory were unsuccessful. There are a number of explanations for why no activity was detected. For example, in culture fluids, lymphokines are only present in pg-ng /ml concentrations and thus very large volumes are required to overcome losses on separation (Gearing, 1989). Therefore, it seems likely that this was a problem when trying to purify the Con A-SNs, since only about 20mls were available for purification.

## CHAPTER 6

### ATTEMPTS TO CHARACTERISE AND ISOLATE SPLENOCYTE DENDRITIC CELLS

#### 6.1 INTRODUCTION

The work presented in this final Chapter was, in fact, undertaken at the beginning of my Ph.D. studies. Although the findings are somewhat incomplete, the experiments represent my initial attempts to characterise aspects of the *Xenopus* MLC, which the subsequent lymphokine experiments explored in more detail. The aim of this preliminary study was to try to identify, isolate and probe the function of certain *Xenopus* antigen presenting cells (APCs) called dendritic cells.

APCs are included under the general term "accessory cells". A variety of APC types can "present" antigen to sensitised T cells, i.e. T cells that have been previously stimulated by antigen or mitogen, (Austyn, 1988). Such APCs express class II MHC antigens, which can present antigenic peptides to sensitised T cells. For example, B lymphocytes, B blasts or B lymphomas, class II transfected fibroblasts, peritoneal macrophages expressing class II (induced with gamma-interferon ( $\gamma$ -IFN)), and even liposomes containing purified class II MHC molecules, can all present antigen to previously-activated T cells, to elicit secondary immune responses (Shimonkevitz *et al*, 1983; Chesnut, Colon & Grey, 1982;

Malissen *et al*, 1984; Inaba & Steinman, 1984; Walden, Nagy and Klein, 1985). In contrast to the above types of APC, dendritic cells (DCs) may be the only cell type that can elicit a primary immune response from "resting" T cells. These are T cells that have not been sensitised by *in vivo* or *in vitro* stimulation. Thus DCs are said to play an "immunostimulatory" role, by activation of resting T cells, either *in vivo* or *in vitro*. These DCs possess a number of morphological and functional characteristics.

Mammalian DCs include interdigitating cells (IDCs) and Langerhans cells. In mammals, IDCs are found in the T cell rich areas of the lymphoid tissue, such as spleen and lymph node; they are also found in the medulla of the thymus. Langerhans cells are a distinctive DC type found in the skin. Mammalian DCs are bone marrow-derived and, as their name implies, are dendritic in morphology, and produce a variety of cell processes, including pseudopods, dendrites or veils. DCs have lobulated nuclei and, in addition, they constitutively express class II molecules on their cell surface (Austyn, 1987; Steinman, 1981; Sunshine, Katz & Feldman, 1980; Steinman *et al*, 1983).

In mammals, the DC (isolated from spleen) has been shown to be a potent stimulator of *in vitro* responses such as mixed leucocyte reactions (MLR; Sunshine, Katz & Czitrom, 1982; Green & Jotte, 1985; Inaba & Steinman, 1986). Dendritic cells have also been shown to be of primary importance in the *in vitro* generation of Tc cells

from  $T_c$  precursors (Rollinghoff, Pfizenmaier & Wagner, 1982; Steinman *et al*, 1983) and  $T_h$  cell proliferation in response to soluble antigen (Sunshine, Katz & Feldman, 1980; Guidos, Wang & Lee, 1984). *In vitro* DCs are found in close contact with lymphocytes. Cell to cell contact appears to be a prerequisite to elicit successful immunostimulation in such responses as MLC,  $T_c$  generation and proliferative responses to soluble antigens (Inaba & Steinman, 1986; Inaba, Witmer & Steinman, 1984; Austyn, Weinstein & Steinman, 1988). *In vivo* the mammalian DC is thought to be the passenger leucocyte involved in promoting acute allograft rejection (Lechler & Batchelor, 1982; Silvers *et al*, 1987; Benson *et al*, 1987; Odling, Halliday & Muller, 1987).

DCs should be contrasted with the follicular dendritic cells (FDCs) found in the B cell areas of lymphoid tissues (Klaus *et al*, 1980). FDCs have a DC morphology, but it is thought that they may have originated from fibroblastic reticulum cells rather than being bone marrow derived. In addition to being localised in the B cell (rather than T cell) areas of lymphoid tissue, FDC also differ from DCs in that they retain antigen-antibody complexes on their surfaces, and do not constitutively express MHC class II antigens.

Baldwin and Cohen (1981) described a cell, dendritic in morphology, in the spleen of *X.laevis*. This cell type was located in the periphery of the white pulp follicles of the spleen, which are B cell rich areas of this lymphoid tissue. In some cases the dendritic processes

extended into the marginal zone. This location suggests resemblance to the mammalian FDC. In *Xenopus* spleen, this dendritic cell, with hyperlobulated nucleus and distinct cell processes, was named the "XL" cell. These cells were previously known as "degenerating macrolymphocytes" (see discussion Manning, 1971). The XL cells appear to trap and transport foreign material (human IgG and colloidal carbon) from the T cell rich zone [found just outside the white pulp follicles and which is the initial entry site of antigen (Collie, 1974; Horton & Manning, 1974], across the B cell follicle boundary into the B cell rich follicle of the *Xenopus* spleen (Baldwin & Cohen, 1981).

Further studies showed that *X.laevis* XL cells are glass-adherent and are able to cluster with lymphocytes *in vitro* to form a primitive follicle-like structure (Baldwin & Sminia, 1982). Thus, although XL cells are located in the B cell areas, as are mammalian FDC, they show some similarities to mammalian DCs, in that the latter also have a dendritic morphology, are glass adherent and associate with lymphocytes when in suspension (Steinman *et al*, 1979; Inaba & Steinman, 1986; Austyn, Weinstein & Steinman, 1988).

Large cells with a dendritic morphology and capable of retaining antigen have also been identified in the spleens of *X.laevis* by other workers (Collie, 1974; Mughal, 1984). The antigen-retaining cells were identified by giving multiple injections of human IgG to *X.laevis* prior to sacrifice, then subsequently staining spleen sections with fluorescent anti-human IgG antibody



(Collie, 1974; Horton & Manning, 1974; Mughal, 1984). Mughal suggests that the antigen-retaining cells may also be the dendritic (XL) cells described by Baldwin and Cohen (1981); since they are large and dendritic in morphology. Fluorescent labelling also identifies their location in the B cell rich zones of the spleen. It was also demonstrated that this antigen-retaining cell population could be enriched by separating splenocyte suspensions on Percoll gradients (Mughal, 1984). In addition there is evidence for dendritic cells, which may have antigen presenting capacity in the *Xenopus* thymus (Turpen & Smith, 1986; Crouse, Turpen & Sharp, 1985). Du Pasquier and Flajnik (1987) have demonstrated the existence of dendritic cells in *Xenopus* skin that are strongly class II positive and so resemble Langerhans cells.

In this Chapter, experiments were performed to identify *Xenopus* DCs on the basis of such criteria as the presence of pseudopods and veils, multi-lobed nuclei, ability to retain soluble antigen (human IgG) and the constitutive expression of surface class II MHC molecules (using the McAb AM20: Du Pasquier and Flajnik (1987)). Functional studies were also undertaken in order to examine the role of various splenocyte populations in stimulating the *Xenopus* MLC. These studies involved attempts to either enrich for DCs, using splenocyte separation over Percoll density gradients, or to deplete such cell types, through their expected adherence to plastic surfaces (Baldwin & Sminia, 1982).

## 6.2 MATERIALS AND METHODS

### 6.2.1 Animals

*X.laevis* were 1-2 years of age when used in these experiments. Clonal animals, LM3, LG17 and LG15 were 6-8 months old when used.

### 6.2.2 Percoll density gradients

In previous experiments putative DCs from *Xenopus* splenocyte populations were separated on Percoll densities of 1.07g/ml and 1.08g/ml (Mughal, 1984).

In the present experiments Percoll (Pharmacia) of density 1.07g/ml or 1.08g/ml was made up using a one-step procedure, as detailed below.

One tenth of the final desired volume of Percoll solution was comprised of 1.5M NaCl (Sigma). To this the required volume of Percoll (direct from the stock bottle) was added, and the final volume made up with distilled water. The formula for calculating the required volume of Percoll is:-

$$V_0 = V \frac{\rho - 0.1 \times \rho_{1.0} - 0.9}{\rho_0 - 1}$$

---

$$\rho_0 - 1$$

where  $V_0$  = vol. of Percoll from bottle (ml)  
 $V$  = vol. of final working solution (ml)  
 $\rho$  = desired density of the final solution  
(g/ml)  
 $\rho_0$  = density of Percoll (1.13  $\pm$  0.005g/ml)  
 $\rho_{10}$  = density of 1.5M NaCl (1.058g/ml)

e.g. If 100mls of Percoll with a density of 1.07g/ml is required then to 10mls of 1.5M NaCl add:

$$V_0 = 100 \frac{1.07 - 0.1 \times 1.058 - 0.9}{1.13 - 1}$$

$$V_0 = 49.3$$

Thus, 49.3ml Percoll (from the bottle) would be added to the 10ml NaCl and 40.7ml distilled H<sub>2</sub>O added to make 100ml of 1.07g/ml Percoll.

The density of the Percoll solutions was checked using density marker beads (Pharmacia) of densities 1.064, 1.077 and 1.09 g/ml. The beads are calibrated to  $\pm$  0.0005g/ml.

### 6.2.3 Separation of spleen cells on Percoll

Percoll solutions of densities 1.08g/ml and 1.07g/ml were sequentially placed in a 10ml centrifuge tube (Sterilin) in the ratio of 3:4 (mls). Using a Pasteur pipette, splenocytes from either antigen-injected animals (for fluorescence experiments) or control animals (for MLC and PHA work) at a concentration of no more than  $10 \times 10^6$  leucocytes/ml (in AL-15:FCS(1%) if cells were to be cultured, or 5:3~~v~~(L-15:d.d.H<sub>2</sub>O) medium if they were to be labelled with fluorescent antibody) were gently layered (in 2ml medium) onto the Percoll. The cells were then spun at 350g for 30 mins at 4°C. Splenocytes were removed from the top layer (the layer on top of the Percoll of 1.07g/ml density) and the bottom cell pellet using a Pasteur pipette, and washed twice (see Fig. 6.1); [cells at the interface (1.07/1.08g/ml) were not usually used].

### 6.2.4 Protocol for the enrichment of "non-adherent" splenocytes for use as stimulators in MLC

Splenocyte suspensions from control animals were plated out in 2ml aliquots ( $2-4 \times 10^6$  leucocytes/ml) in AL-15:FCS(10%) into small (30mm x 10mm) sterile tissue culture grade petri dishes (Costar). The dishes were then incubated ( $26 \pm 1^\circ\text{C}$ ) for 2hrs (since mammalian DCs adhere to plastic by 2hrs, this time point was chosen as the incubation time for the *Xenopus* cells). During this time,

at half hourly intervals, the dishes were rocked gently to ensure cell contact with the plastic. After 2 hours incubation the non-adherent *Xenopus* splenocytes were gently pipetted off.

As a control to the above treatment, other splenocytes were incubated for the same amount of time in round bottom 5ml plastic centrifuge tubes (Falcon). This "treatment" was designed to minimise cell contact with the plastic surface.

#### 6.2.5 Injection of human immunoglobulin G

Human IgG (Sigma) was dissolved in APBS (diluted from 10 times concentrate: Flow Labs) and injected via the dorsal lymph sac (DLS) into *X.laevis* toads of approximately 15g weight. The dose used was 0.03mg/g body weight i.e. 0.5mg total human IgG was administered for a 15g animal in a volume of 300 $\mu$ l. 24hours after injection the toad was sacrificed and a splenocyte suspension made as detailed in section 6.2.3.

#### 6.2.6 Identification of human IgG associated with spleen cells by fluorescence microscopy: studies on cell suspensions and cell smears

The procedure was carried out on ice using 5:3 $\sqrt{v}$ (L-15:d.d.H<sub>2</sub>O) medium (see Appendix).

Spleen suspensions, from *Xenopus* previously injected with human IgG, were washed in medium and then goat anti-human IgG FITC-labelled antibody (Sigma) was added at a concentration of 1/30. After 30min incubation, in the dark, the splenocytes were washed twice and resuspended in 20 $\mu$ l of medium. A drop (10 $\mu$ l) of the suspension was placed on a glass slide and a coverslip applied. The cells were then viewed under a fluorescence microscope (Nikon). Spleen suspensions from uninjected control animals were also incubated with fluorescent antibody. 400 leucocytes per experimental sample were counted and scored as either fluorescence positive (i.e. "binding" human IgG) or fluorescence negative.

Since Mughal (1984) was able to show the presence of human IgG-retaining cells in cytopsin preparations of cell suspensions, attempts were made to produce such preparations in this laboratory. This would yield the opportunity to study putative "XL" cells in a fixed cell smear and compare the morphology of these with the fluorescent-positive cells in a spleen cell suspension.

Splenocyte suspensions from toads previously injected with IgG, were adjusted to a concentration of 2 x 10<sup>6</sup> leucocytes/ml in APBS. 50 $\mu$ l of leucocyte suspension plus 50 $\mu$ l (0.2 $\mu$ m) filtered FCS (Gibco) were added to the cytopsin vials. The splenocytes were spun at 600rpm for 4 mins in a Shandon cytopsin; this transfers the cells to a microscopic slide. The slides, with the transferred cells, were air dried for 30 min then fixed in methanol for 1-2 min.

Cytospin preparations were stained by adding a few drops of goat anti-human IgG (Sigma) antibody (1/15 final concentration) and incubated in a dark humid atmosphere for 30 min. Slides were then gently washed by immersion in APBS in coplin jars. The preparations were mounted in APBS and viewed under a fluorescence microscope.

#### 6.2.7 Identification of class II MHC positive cells by fluorescence microscopy

AM20 is a mouse IgG McAb directed against class II molecules on *Xenopus* cells. The hybridoma cell line that produces AM20 was a generous gift from Dr M. Flajnik, Basel Institute of Immunology.

Splenocytes from control *Xenopus* (i.e. not injected with human IgG) were kept on ice throughout the procedure. They were incubated with AM20 culture SN, diluted 1/5 in 5:3 <sup>(L-15:cdH<sub>2</sub>O)</sup> medium, for 30 min. The AM20 stained splenocytes were then washed twice and subsequently incubated with secondary antibody for 30 mins. Secondary antibody was a 1/30 dilution of either FITC-labelled anti-mouse IgG antibody (Sigma) or FITC-labelled anti-mouse IgG [(Fab)<sub>2</sub> fragment] (Dakopats). Subsequently, splenocytes were again washed twice, before aliquots were viewed under a fluorescence microscope (Nikon).

"Control" staining involved splenocytes labelled with FITC labelled secondary antibody only.

#### 6.2.8 PHA-M assay

AL-15:FCS(1%) was used in these experiments. Spleen cells were adjusted to a concentration of  $1 \times 10^6$  viable leucocytes/ml and 100 $\mu$ l aliquots were dispensed into 96-well V-based plates (Cell Cult: Sterilin). PHA-M (Flow Labs) was added in 10 $\mu$ l aliquots to give a final "in well" concentration of 1/500 (shown elsewhere to be optimal for inducing mitosis). Control cultures were given 10 $\mu$ l of AL-15:FCS(1%) instead of PHA. Splenocytes were cultured at  $26 \pm 1^\circ\text{C}$  and in 5%  $\text{CO}_2$ . After 48hr culture, each well was pulsed with 1 $\mu$ Ci [ $^3\text{H}$ ]TdR (Amersham; Sp.A. = 5Ci/mmol) and harvested 24hr later. Samples were then analysed on a scintillation counter. The stimulation index was calculated using the following formula:

$$\text{SI} = \frac{\text{PHA-M cultures (dpm)}}{\text{Medium cultures (dpm)}}$$

#### 6.2.9 Mixed leucocyte culture assay

Responder and stimulator spleen cell suspensions were prepared in AL-15:FCS(10%) (this concentration was used since mammalian workers use relatively high FCS-supplementation when culturing DCs). Stimulator cells



were given an irradiation dose of 6000R from a  $^{60}\text{Co}$  source. Responder cells were adjusted to a concentration of  $1 \times 10^6$  viable leucocytes/ml, whereas stimulators were adjusted to a concentration of  $5 \times 10^5$  leucocytes/ml. 100 $\mu\text{l}$  aliquots each of the responder and stimulator splenocyte suspensions were dispensed into 96-well V-based plates (Cell Cult: Sterilin). Control cultures consisted of 200 $\mu\text{l}$  of irradiated stimulator suspension, or 200 $\mu\text{l}$  irradiated responder suspension, or 100 $\mu\text{l}$  responder cells with 100 $\mu\text{l}$  irradiated responder cells; all adjusted to have the same cell number/well as the experimental cultures. Splenocytes were incubated at  $26 \pm 1^\circ\text{C}$  and in 5%  $\text{CO}_2$ . After 72 hours, each well was pulsed with 1 $\mu\text{Ci}$  [ $^3\text{H}$ ]TdR (Amersham: Sp.A.= 5Ci/mmol) and harvested 24 hours later. Samples were then analysed on a scintillation counter.

Stimulation indices were calculated using the following formula (unless stated otherwise):

$$\text{SI} = \frac{\text{resp.} \times \text{stim.}^{\text{R}} - \text{stim.}^{\text{R}}(200\mu\text{l})/2}{\text{resp.} \times \text{resp.}^{\text{R}} - \text{resp.}^{\text{R}}(200\mu\text{l})/2}$$

---

$$\text{resp.} \times \text{resp.}^{\text{R}} - \text{resp.}^{\text{R}}(200\mu\text{l})/2$$

## 6.3 RESULTS

### 6.3.1 Fluorescence microscopic studies on antigen-retaining splenocytes

#### 6.3.1.1 Antigen retention by splenocytes: enrichment by Percoll separation

Spleen cell suspensions from animals previously injected (24hr) with human IgG routinely showed a small, but distinct population of cells that retained human IgG (Fig. 6.3). These cells were large ( $20\mu\text{m}$ ), had pseudopods and possessed hyperlobulated nuclei with prominent nucleoli (Fig. 6.2) i.e. they possessed characteristics of "XL" cells. This human IgG<sup>+</sup> population could be enriched by separation on Percoll. Collecting the top layer from the Percoll raised the average percentage of human IgG<sup>+</sup> splenocytes from  $0.26 \pm 0.1\%$  (unseparated cells) to  $4.2 \pm 0.9\%$ . The splenocytes retrieved from the cell pellet (CP) were  $0.24 \pm 0.2\%$  human IgG<sup>+</sup>, (see Table 6.1).

The number of leucocytes retrieved from the top layer was  $8.7 \pm 2.0\%$  of the total, whereas the cell pellet contained  $23 \pm 4.3\%$  of the total leucocytes. The cells unaccounted for by these fractions were present in the middle layer, at the interface of the two Percoll densities and in the Percoll itself.

#### 6.3.1.2 Morphology of human IgG<sup>+</sup> splenocytes: use of cytopsin preparations

Cytopsin preparations revealed that splenocytes with bound human IgG possessed distinct morphological characteristics. They were large cells, 15-20 $\mu$ m in diameter, and irregularly shaped, often with pseudopodia. In addition, the human IgG<sup>+</sup> cells had lobed nuclei with a dense ring of heterochromatin around the nuclear membrane and possessed distinct nucleoli. They were nearly always observed in association with lymphocytes (Fig. 6.4).

#### 6.3.1.3 Staining with anti-Xenopus class II monoclonal antibody (AM20)

In splenocyte suspensions of control *X.laevis* AM20 appeared to label the majority of leucocytes, which often capped the antibody (Fig. 6.5). Cells with the morphological features of human IgG-retaining cells described above (section 6.3.1.1) were also stained with this anti-class II antibody (Fig. 6.5). Ideally, a double staining protocol, using two different fluorochromes attached directly to the AM20 antibody (and to the anti-human IgG antibody), to test for the ability of cells to retain human IgG and to express class II MHC molecules, would have shown if a single cell could display both these properties.

### 6.3.2 Response of Percoll separated and unseparated Xenopus splenocytes to PHA-M

Splenocytes from non antigen-injected animals were used for these experiments. In all cases the unseparated, top layer (TL) and cell pellet (CP) fractions all produced significant responses to PHA-M (Table 6.2). In 2 experiments out of 3, splenocytes from the CP gave higher PHA-induced stimulation indices than either the TL or unseparated splenocyte populations. In the 3<sup>rd</sup> experiment SIs were high in all cases, with the highest SI recorded for the TL.

Overall, splenocytes recovered from the TL or CP were able to proliferate in a standard T cell assay. Clear evidence for enrichment of PHA reactivity following Percoll separation was therefore not obtained.

### 6.3.3 Ability of Percoll-separated and -unseparated splenocytes to stimulate in one-way MLC

6000R irradiated spleen populations of unseparated and Percoll-separated TL and CP fractions from control animals were all effective as stimulator cells when set up in MLC against non-irradiated unseparated responders (Table 6.3). The magnitude of the responses of the responder cells when cultured with the different stimulator spleen populations were similar - i.e. there was no clear cut evidence that the top layer of cells

(enriched for cells able to retain injected soluble antigen (see section 6.3.1.1)) were better stimulators.

#### 6.3.4 Ability of plastic non-adherent splenocytes to stimulate in one-way MLC

The goal of these experiments was to examine the effect of removing adherent cells (dendritic rich?) from the stimulator population for assay in MLC.

The "complete" population of leucocytes proved a better stimulator population than the non-adherent cell population ( $p < 0.01$ ), when assayed for stimulatory capacity in MLCs (Table 6.4). Both populations, however, induced significant ( $p < 0.001$  for control cultures and  $p < 0.02, 0.01$  &  $0.001$  for the non-adherent populations) responses from the responder splenocytes. Adherent cells were not tested for their ability to stimulate in these experiments.

FIG. 6.1

Separation of leucocytes involved separation over Percoll gradients of densities 1.07g/ml and 1.08g/ml.

FIG. 6.1 SEPARATION OF LEUCOCYTES OVER PERCOLL GRADIENTS

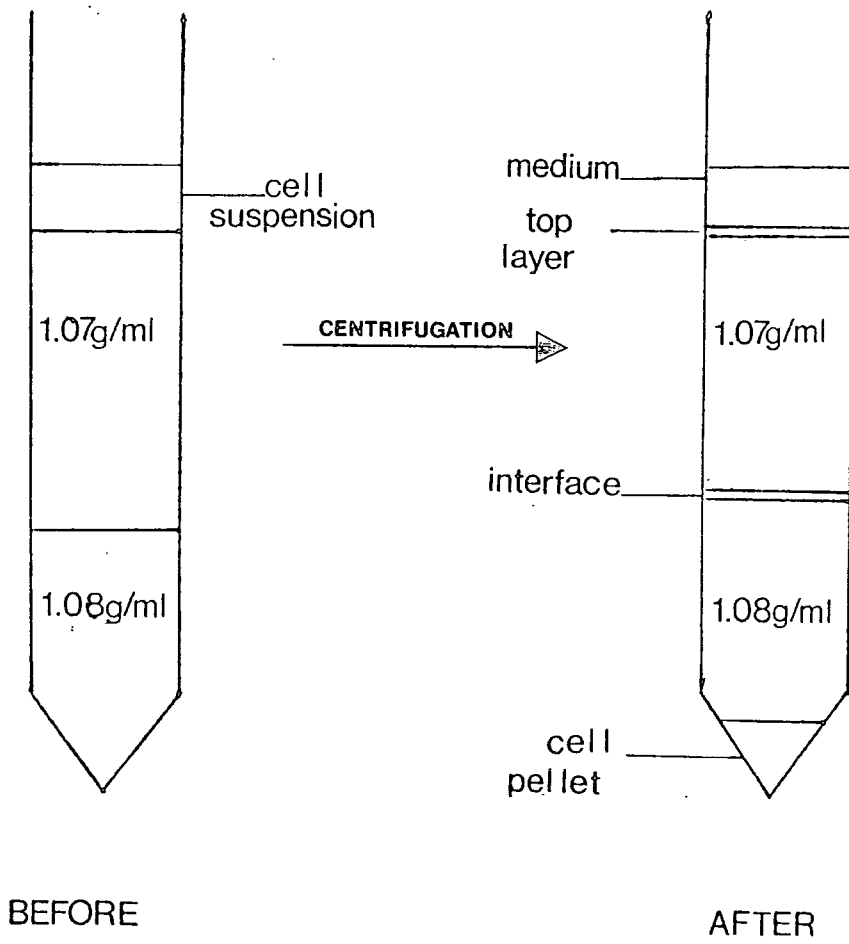

FIG 6.2

*X.laevis* splenocyte suspension showing three "XL-like" cells with "dendritic" morphology, including lobed nuclei, distinct nucleoli, pseudopods and characteristic clustering with leucocytes.

(Phase contrast. Obj.x40, Magnification x400)



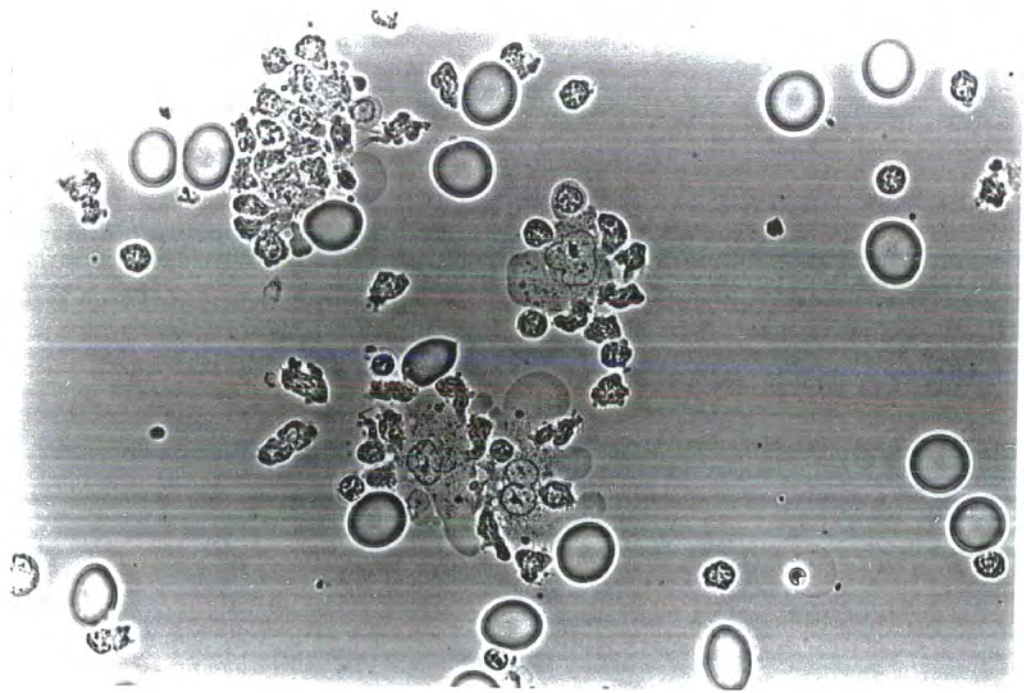

FIG. 6.3

*X.laevis* splenocyte suspensions from animals injected previously with human IgG, and subsequently (24 hours later) stained with an FITC-labelled anti-human IgG.

A. and B. specific "ring" of fluorescence observed in association with XL-like cell.

C. and D. "Speckled" fluorescence associated with XL-like cell.

E. and F. Intermediate type of staining (between ring and speckled staining) observed in association with an XL-like cell. The latter shows distinct pseudopods and clustering characteristics. (Obj. x40, Magnification x400)

A,C & E      UV transmission  
B,D & F      Phase contrast

E



F

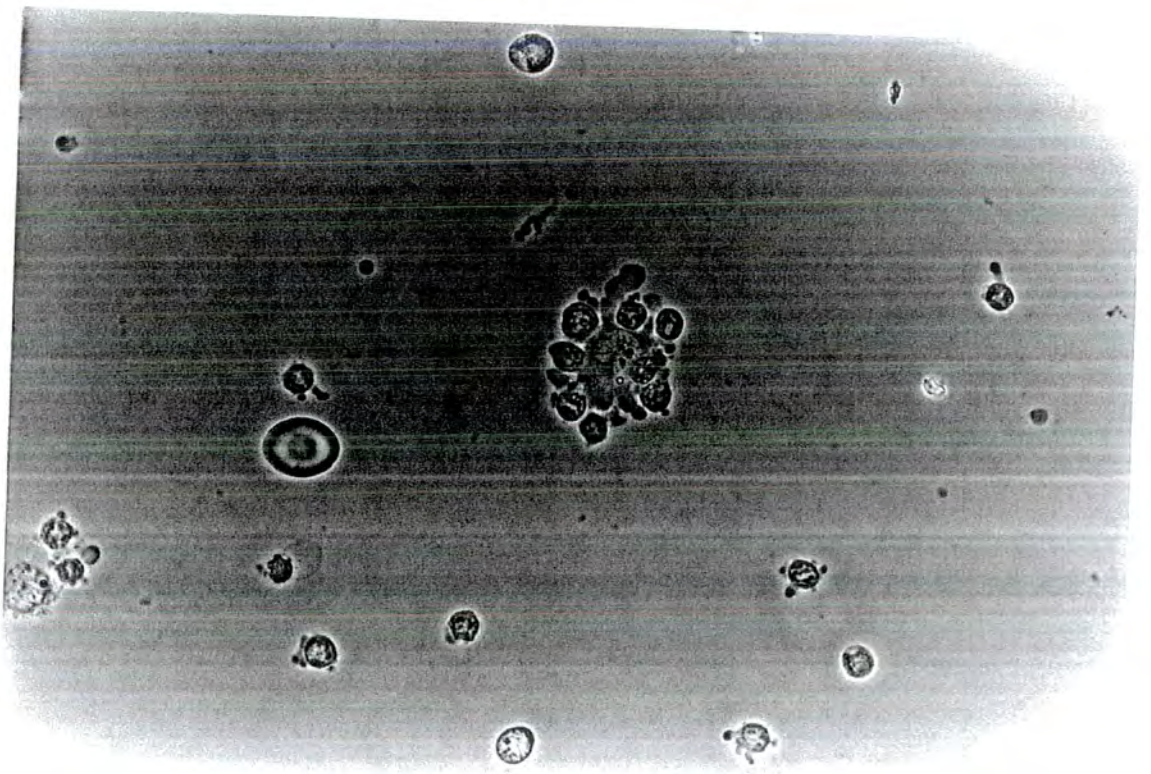

C

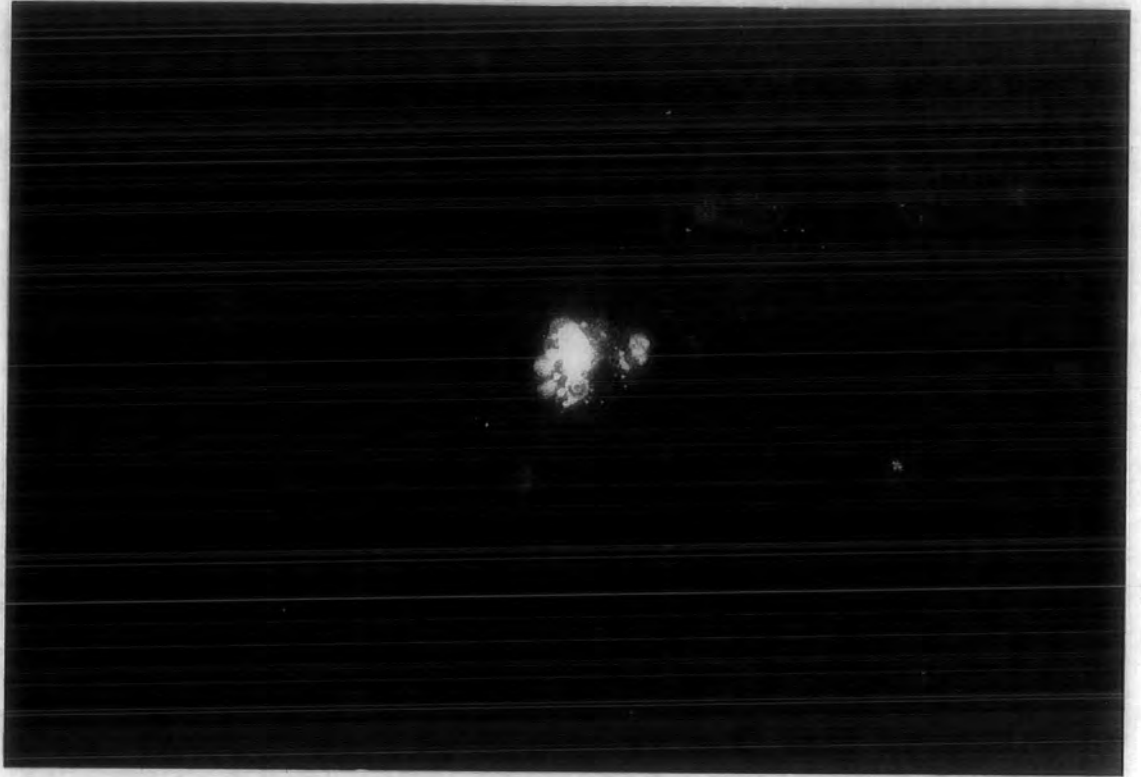

D

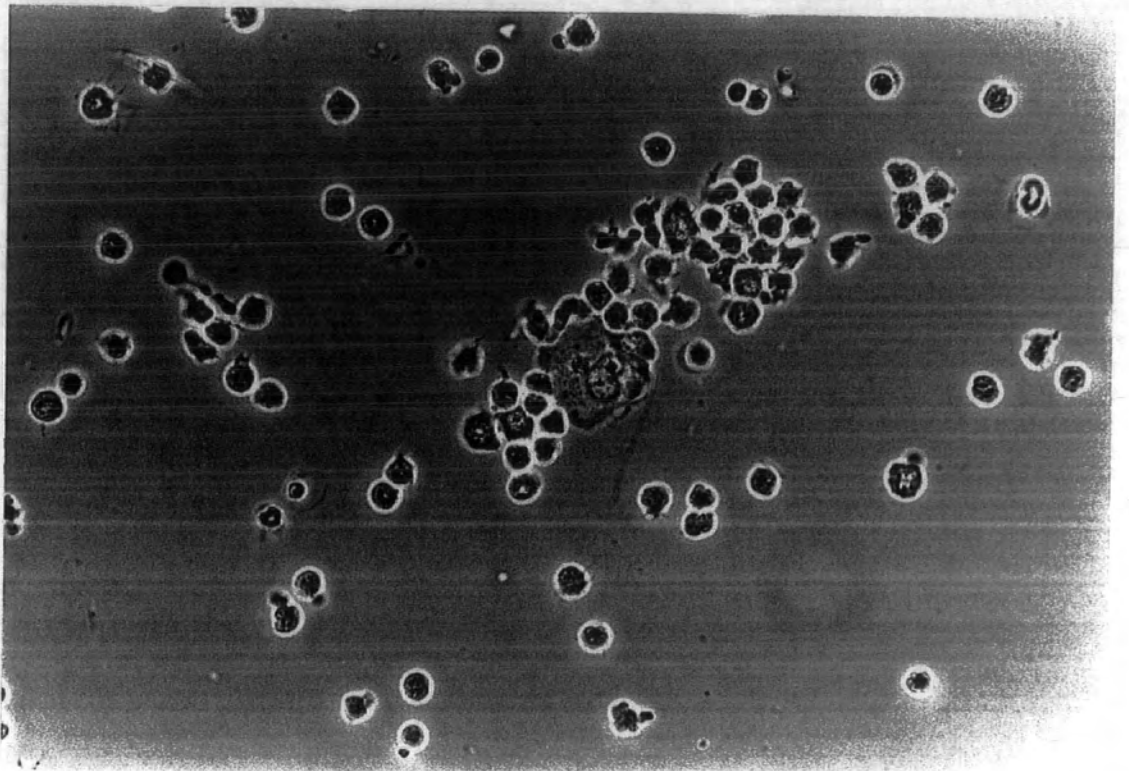



A

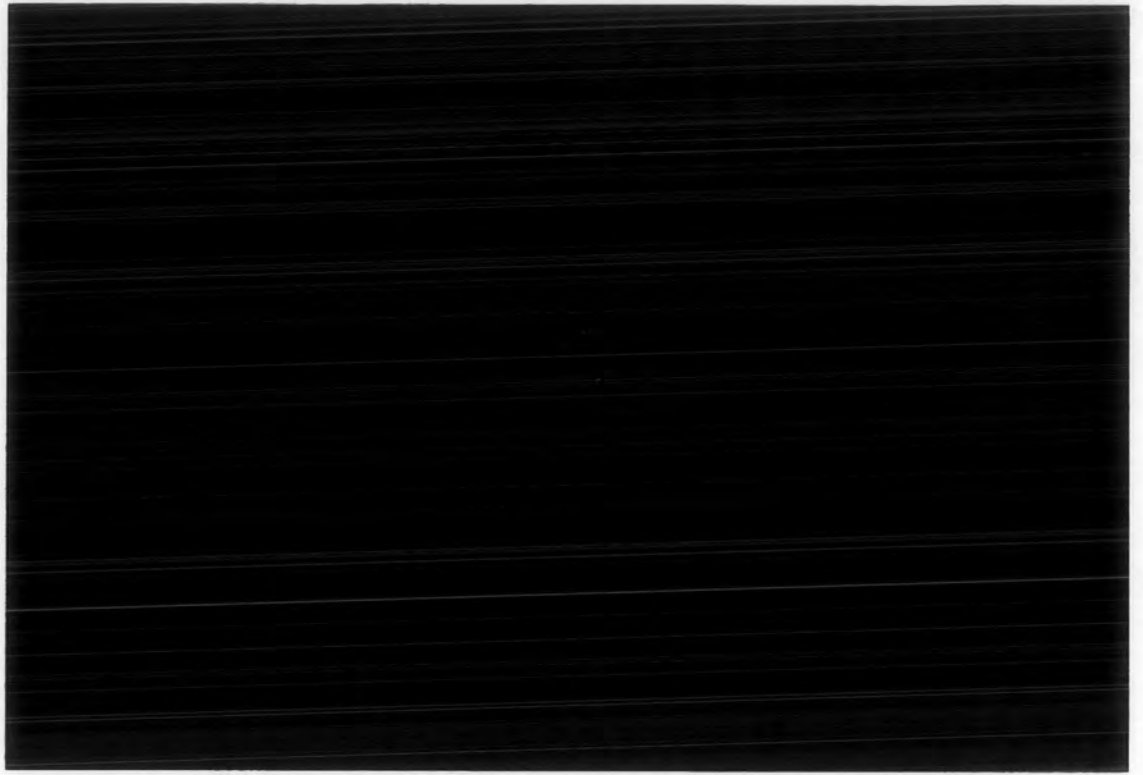

B

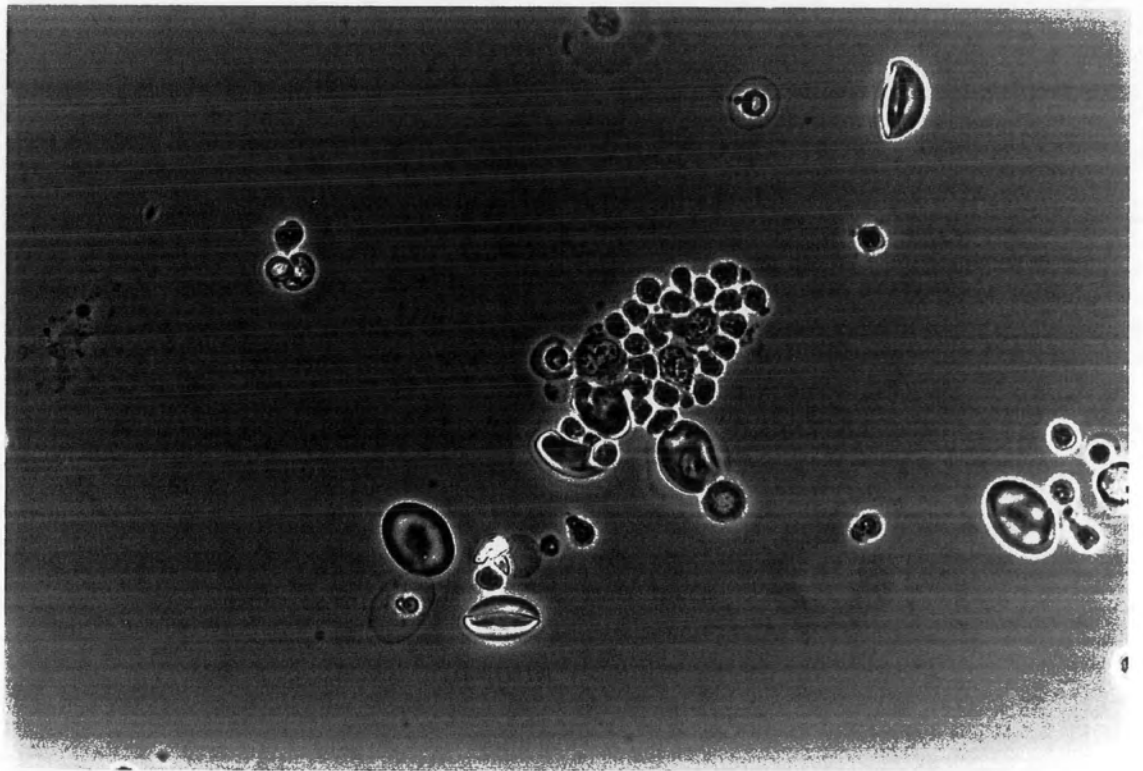

FIG. 6.4

Views under phase contrast and UV transmission of a cytospin preparation of *X.laevis* splenocytes from an animal injected previously with human IgG, and subsequently stained with an FITC-labelled anti-human IgG.

Note large cells with specific fluorescence (Obj. x40, Magnification x400)

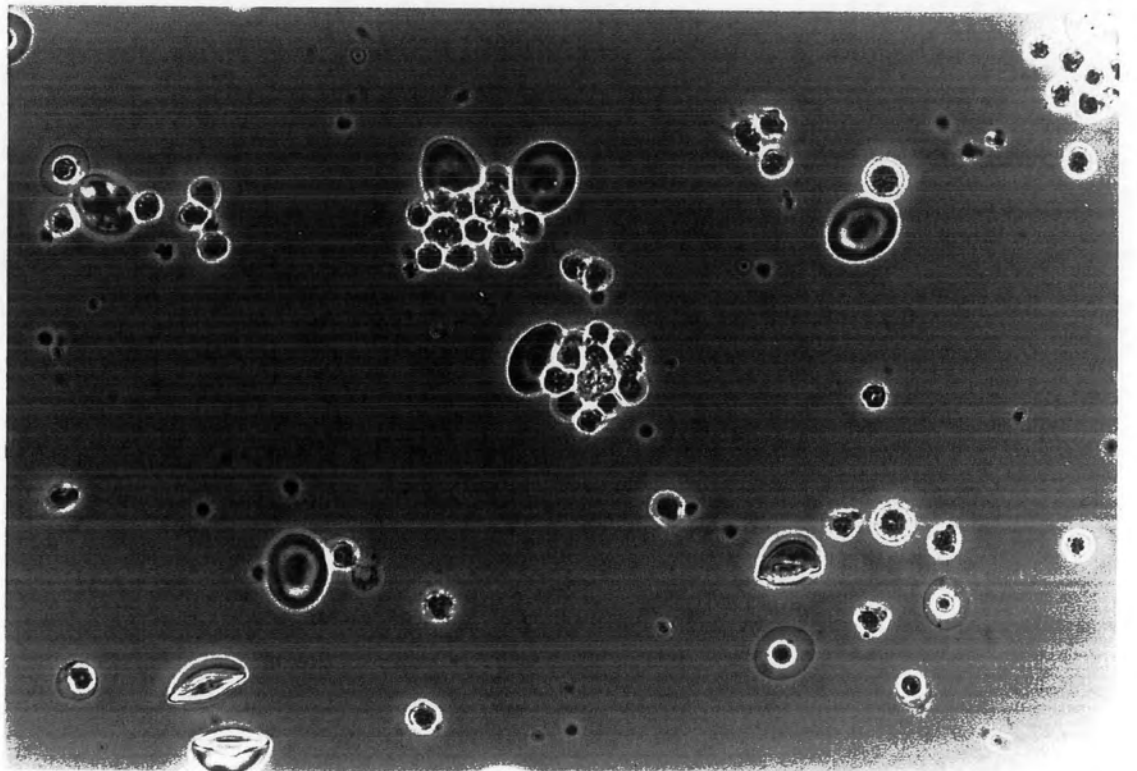

FIG. 6.5

Views under phase contrast and UV transmission of *X.laevis* splenocyte suspensions labelled with the anti-class II McAb, AM20, and subsequently labelled with an FITC-labelled anti-mouse Ig antibody.

Large XL-like cells stain positively, in addition to leucocytes which tend to "cap" the antibody (Obj. x40, Magnification x400).



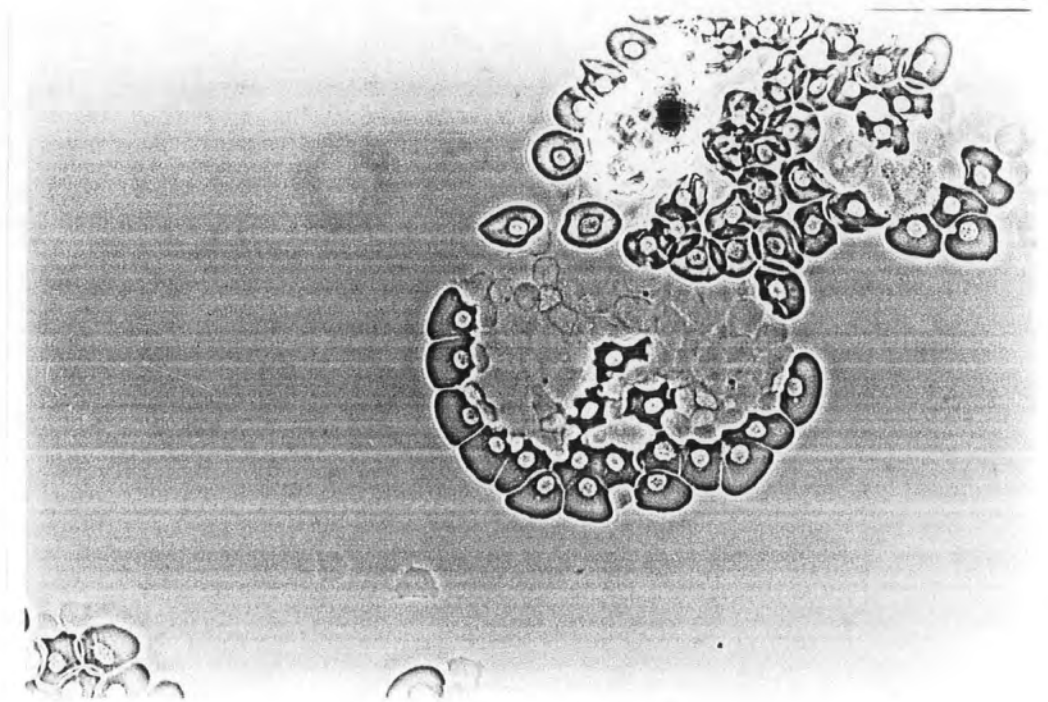

TABLE 6.1

Spleen cell suspensions taken from *X.laevis*, that had been injected 24 hours previously with human IgG, were separated on a Percoll gradient (1.07 and 1.08g/ml). The top layer (TL) and cell pellet (CP) only were collected and stained with a rabbit FITC-anti-human IgG antibody. Unseparated cells were also stained and counted. 400 leucocytes per experimental sample were counted and scored as human IgG-positive or -negative. In addition, the yield of leucocytes was counted (see text) using the following formula:

$$\text{Yield} = \frac{\text{no. of leucocytes recovered from TL/CP} \quad \times 100}{\text{total no. of leucocytes before separation}}$$

Composite results from 4 experiments, using separate animals, are shown.

TABLE 6.1 PERCENTAGE OF HUMAN IgG+ SPLENOCYTES:  
EFFECT OF PERCOLL SEPARATION

| splenocyte population:           |                |                |                |
|----------------------------------|----------------|----------------|----------------|
|                                  | unseparated    | top layer      | cell pellet    |
| human IgG+<br>mean $\pm$ sem (%) | 0.26 $\pm$ 0.1 | 4.28 $\pm$ 0.9 | 0.24 $\pm$ 0.2 |

TABLE 6.2

*X. laevis* spleen cell suspension was separated on a Percoll density gradient (1.07:1.08g/ml), and the top layer (TL) and cell pellet (CP) were collected and used for assay. Splenocytes were dispensed out at  $1 \times 10^5$  leucocytes/well in AL-15:FCS(1%) in 96-well V-based plates. PHA-M was added to give a final "in well" dilution of 1/500. Cultures were set up in triplicate.

After 48 hours in culture, each well was pulsed with  $1\mu\text{Ci}$  [ $^3\text{H}$ ]TdR and harvested 24 hours later.

TABLE 6.2 ABILITY OF PHA-M TO STIMULATE PERCOLL SEPARATED  
AND UNSEPARATED *X. LAEVIS* SPLENOCYTES

splenocyte population:

| expt.<br>no.               | unseparated                                  |   | top layer                                   |                 | cell pellet     |                 |
|----------------------------|--|---|---|-----------------|-----------------|-----------------|
|                            | no PHA<br>+ PHA                              | no PHA<br>+ PHA                         | no PHA<br>+ PHA                             | no PHA<br>+ PHA | no PHA<br>+ PHA | no PHA<br>+ PHA |
| mean dpm $\pm$ sem<br>[SI] |  |   |   |                 |                 |                 |
| 1                          | 210 $\pm$ 13<br>1582 $\pm$ 163<br>[7.5]      | 106 $\pm$ 9<br>539 $\pm$ 45<br>[5.1]    | 220 $\pm$ 38<br>3266 $\pm$ 107<br>[15.0]    |                 |                 |                 |
| 2                          | 184 $\pm$ 25<br>1749 $\pm$ 113<br>[9.5]      | 161 $\pm$ 29<br>1061 $\pm$ 67<br>[6.6]  | 257 $\pm$ 25<br>4612 $\pm$ 181<br>[18.0]    |                 |                 |                 |
| 3                          | 1621 $\pm$ 137<br>46848 $\pm$ 1315<br>[29.0] | 186 $\pm$ 12<br>8736 $\pm$ 91<br>[47.0] | 1008 $\pm$ 129<br>30270 $\pm$ 967<br>[30.0] |                 |                 |                 |

TABLE 6.3

Spleen cell suspensions were separated on a Percoll density gradient (1.07:1.08g/ml), and the top layer (TL) and cell pellet (CP) were collected. These populations were irradiated (6000R) and were used as stimulators in a one-way MLC. Responder splenocytes ( $1 \times 10^5$  leucocytes/well) were cocultured with 6000R irradiated stimulators ( $5 \times 10^4$  leucocytes/well) in 96-well V-based plates in AL-15:FCS(1%). Cultures were set up in triplicate.

After 72 hours in culture, each well was pulsed with  $1\mu\text{Ci}$  [ $^3\text{H}$ ]TdR and harvested 24 hours later.

$$\text{SI} = \frac{\text{responder x stimulator}^{\text{R}} \text{ cultures (dpm)}}{\text{responder x responder}^{\text{R}} \text{ cultures (dpm)}}$$

(Stimulator<sup>R</sup> and responder<sup>R</sup> = irradiated populations.)

TABLE 6.3 ABILITY OF PERCOLL -SEPARATED AND -UNSEPARATED SPLENOCYTES  
TO ACT AS STIMULATORS IN ONE-WAY MLCs

| MLC combination |                 | 6000R irradiated stimulator population: |                         |                         |                         |
|-----------------|-----------------|---|-------------------------|-------------------------|-------------------------|
| resp.           | stim.R          | resp. x resp.R                          | unseparated             | top layer               | cell pellet             |
| background      |                 | mean dpm $\pm$ sem<br>[SI]              |                         |                         |                         |
| LG17            | <i>X.laevis</i> | 280 $\pm$ 25                            | 881 $\pm$ 99<br>[4.0]   | 1054 $\pm$ 133<br>[5.4] | 1147 $\pm$ 127<br>[5.8] |
| LM3             | LG17            | 526 $\pm$ 89                            | 3174 $\pm$ 174<br>[6.6] | 2003 $\pm$ 226<br>[4.1] | n.d.                    |
| LM3             | LG17            | 646 $\pm$ 61                            | 3057 $\pm$ 50<br>[6.0]  | 2092 $\pm$ 141<br>[4.1] | n.d.                    |

TABLE 6.4

Spleen cell suspensions were incubated in petri dishes ( $2 \times 10^6$  leucocytes/ml) in AL-15:FCS(10%) for 2 hours. Non-adherent cells were then collected and used as stimulators in one-way MLC. Control splenocyte stimulators were incubated in round based tubes.

Responder splenocytes ( $1 \times 10^5$  leucocytes/well) were cocultured with 6000R irradiated stimulators ( $1 \times 10^5$  leucocytes/well) in 96-well V-based plates in AL-15:FCS(1%). Cultures were set up in triplicate. After 72 hours in culture, each well was pulsed with  $1\mu\text{Ci}$  [ $^3\text{H}$ ]TdR and harvested 24 hours later.

resp. x non-adherent or control stim. cultures (irrad) (dpm)

SI = \_\_\_\_\_

resp. x resp.(irrad) cultures (dpm)



TABLE 6.4 ABILITY OF PLASTIC NON-ADHERENT SPLENOCYTES TO ACT AS  
STIMULATORS IN ONE-WAY MLC

|                          |                    | 6000R irradiated stimulators: |                      |                      |
|--------------------------|--------------------|-------------------------------|----------------------|----------------------|
| MLC combination<br>resp. | stim. <sup>R</sup> | background                    | control              | non-adherent         |
|                          |                    | resp. x resp. <sup>R</sup>    |                      |                      |
| mean dpm ± sem<br>[SI]   |                    |                               |                      |                      |
| X. laevis                | XbJ                | 976 ± 8                       | 3004 ± 140<br>[3.3]  | 1474 ± 135<br>[1.4]  |
| LM3                      | J/LG15             | 4646 ± 23                     | 7561 ± 21<br>[2.0]   | 5984 ± 237<br>[1.3]  |
| LM3                      | LG15               | 4718 ± 103                    | 22973 ± 544<br>[4.9] | 17706 ± 666<br>[3.8] |

#### 6.4 DISCUSSION

These experiments reveal that *Xenopus* splenocytes that can trap and retain antigen (human IgG), and which seem likely also to express surface class II MHC molecules, are morphologically similar to the XL cells described by Baldwin and Cohen (1981) and Baldwin and Sminia (1982). That is, they are large, irregularly shaped cells with multi-lobed nuclei. They also possess prominent nucleoli, a dense ring of chromatin and have a tendency to attract and cluster with lymphocytes. These features are similar to those described by Mughal (1984) in his identification of human IgG-retaining cells in *Xenopus*.

To further characterise these 'antigen-presenting' cells their morphological characteristics need to be correlated with additional functional studies. Thus, attempts were made to produce an enriched population of the antigen retaining cells, using Percoll density gradients. Percoll-separation produced some (fairly minimal) enrichment of human IgG-retaining cells. However, in functional studies there was no clear evidence to link these 'antigen-presenting' cells with an ability to stimulate in MLC. A much greater enrichment than that attained in these experiments is required to determine the role (if any) of the XL cells in the *Xenopus* MLC. Since anti-class II staining was present on

all *Xenopus* leucocytes, it may be that many MHC class II+ cell types can stimulate in *Xenopus* MLC. These possibilities need to be investigated further.

A separate approach in this Chapter, to probe the nature of the stimulator cells in MLC, has been to remove adherent cells, since this is a technique used in mammalian studies to deplete leucocyte populations of dendritic cells. Spleen cells that did not adhere to plastic upon incubation, were somewhat less effective as stimulators in MLC than the control splenocytes. Thus, it appears that a cell type that adheres to plastic may be of some importance in stimulating responder splenocytes in the *Xenopus* MLC. When examined under light microscopy, plastic adherent cells included cells that were morphologically similar to XL cells; other plastic adherent cells identified in preliminary studies were macrophages and red blood cell precursors (data not shown).

## CHAPTER SEVEN

### MAJOR CONCLUSIONS AND SUGGESTIONS FOR FURTHER WORK

Previous studies have suggested that the amphibian, *Xenopus*, is capable of producing an interleukin-2 (IL-2)-like molecule. The evidence for this comes from the study of supernatants (SNs), with IL-2-like activity, generated *in vitro* by stimulation of *Xenopus* splenocytes with T cell mitogens (phytohaemagglutinin (PHA), Concanavalin A (Con A)). The production of IL-2 activity was also investigated, though to a lesser extent, in SNs produced by alloantigen stimulation (mixed leucocyte culture, MLC). All the SNs generated supported the proliferation of T cell blasts (splenocyte populations that had been mitogen treated to cause the leucocytes to undergo "blastogenesis"), but not the proliferation of "unstimulated" leucocytes. The PHA-ASN also supported growth of T cell blasts, as measured by cell number.

#### Chapters 1 and 2

The work presented in this Thesis demonstrates that when *Xenopus* splenocytes are stimulated by alloantigen (e.g. in MLC) or through mitogen activation (e.g. PHA, Con A) soluble factors are produced from the stimulated cell population that cause mitosis of both *Xenopus* splenoblasts and splenocytes taken directly from the

animal. This is in contrast to the findings of Watkins and Cohen (1987). These authors found that only splenic blasts responded to the ASNs, whilst "unstimulated" splenocytes were unresponsive. It is possible that the splenocytes from the toads in our laboratory were in a different stage of activation, perhaps due to their environment or the culture procedure itself. The activity generated by either alloantigen or mitogen stimulation is not specific to a particular *Xenopus* genotype, i.e. mitosis of splenocytes /lymphoblasts is attained in a variety of strains/species.

With MLC-ASNs maximum stimulatory activity is detected at 48 hours after initiation of culture, with activity remaining high for up to five days, whereas in PHA-ASNs and Con A-ASNs, activity is found to be at its highest after 24 hours of culture with mitogen. In the PHA-ASNs there is generally a small amount of residual PHA left after treatment to remove the mitogen (adsorption over chicken red blood cells). However, in the case of Con A-ASNs addition of  $\alpha$ mm removed all traces of the mitogen, as measured by bioassays, which allowed clearer interpretation of the results from Con A-induced SNs. Attempts to concentrate/purify the activity in the SNs were unsuccessful.

#### Chapters 4 and 5

A novel approach to the culture of *Xenopus* cells was achieved using a miniaturised "hanging drop" technique.

Miniaturisation of the SN screening assay was successfully achieved using only  $1.5 \times 10^4$  leucocytes per 20 $\mu$ l "hanging drop" culture, in the wells of a Terasaki plate.

"Unstimulated" splenocytes from *Xenopus*, thymectomised in early larval life, responded by proliferation to ASNs (MLC-, PHA- or Con A-induced ASNs). Since thymectomised animals are impaired with respect to their T cell functions, this suggested that a cell type other than a T cell (as defined by the monoclonal antibody XT-1) could proliferate in the presence of ASN.

Using an anti-IgM (i.e. anti-B cell) the nature of the cells (from thymectomised animals) that responded to the ASNs was probed. Splenocytes were separated by FACS to yield two populations of cells:- IgM<sup>+</sup>(XTLA-1<sup>-</sup>) and IgM<sup>-</sup>(XTLA-1<sup>-</sup>). Using the miniaturisation technique three different populations (unsorted, IgM<sup>+</sup> and IgM<sup>-</sup>) were assayed for their ability to respond to the SNs. IgM<sup>+</sup> (B cells) responded mildly to the PHA-P-ASN (this was not due to residual PHA-P, since PHA-P administered alone did not cause proliferation in this population). However, the IgM<sup>-</sup> population responded well to both the PHA-P-ASN and the MLC-ASN, and were also responsive to PHA-P alone. Thus, early-thymectomised *Xenopus* possess an IgM<sup>-</sup>(XTLA-1<sup>-</sup>) population of splenocytes that are highly responsive to alloantigen- and mitogen-induced ASNs and respond to the T cell mitogen PHA. This may represent a "T-like" cell in these animals.

The study of the "T-like" population in the thymectomised *Xenopus* is worth further study. For example, if the IgM<sup>-</sup> population was cultured further with ASN, would that population develop the XTLA-1 T cell marker or T cell functions?

Further experiments to concentrate and purify the "active" factors in the SNs are essential and would determine the nature (protein?) and size of the molecule(s) involved. In addition, if purification of the activity in the SNs led to the identification of a protein it would be possible, through the application of molecular biology techniques, to eventually isolate the gene responsible for the production of this protein.

## REFERENCES

Ando I & Hurme M (1981). Self-MHC-restricted cytotoxic T cell response without thymic influence. *Nature*. 281, 494-495.

Arnall JC & Horton JD (1986). Impaired rejection of minor histocompatibility antigen-disparate skin grafts and acquisition of tolerance to thymus donor antigens in allo-thymus implanted, thymectomised *Xenopus*. *Transplantation*. 41, 766-776.

Arnall JC, Horton JD (1987). *In vivo* studies of allotolerance perimetamorphically induced in control and thymectomised *Xenopus*. *Immunology*. 62, 315-319.

Asherson GL, Colizzi V, Malkovsky M, Colonna-Romano G, Zembala M (1985). The role of interleukin-2 as one of the determinants of the balance between immunity and unresponsiveness. *Folia. Biol.* 31, 387-395.

Austyn JM (1988). Antigen-presenting cells. In: *In focus series* (D Male, ed) Oxford University Press in association with the BSI.

Austyn JM, Weinstein DE & Steinman RM (1988). Clustering with dendritic cells precedes and is essential for T-cell proliferation in a mitogenesis model. *Immunology*. 63, 691-696.



Austyn JM (1987). Lymphoid dendritic cells. *Immunology*. 62, 161-170.

Baldwin WM & Cohen N (1981). A primitive dendritic splenocyte in *Xenopus laevis* with morphological similarities to Reed-Sternberg cells. In: *Aspects of Developmental and Comparative Immunology* (JB Solomon, ed) Pergamon Press, Oxford. pp179-182.

Baldwin WM & Sminia T (1982). Antigen-trapping cells: advantages of phylogenetic studies. *Devel. Comp. Immunol.* supplement 2, 59-67.

Bellio M & Dos Reis GA (1989). Triggering of thymocyte function by IL-2 as the only exogenous stimulus: analysis of two distinct modes of IL-2-induced thymocyte proliferation and IL-3 secretion *in vitro*. *Immunology*. 68 175-180.

Benson MT, Buckley G, Jenkinson EJ & Owen JJT (1987). Survival of deoxyguanosine treated fetal thymus allografts is prevented by priming with dendritic cells. *Immunology*. 60, 593-596.

Bernard CCA, Bordmann G, Blomberg B & Du Pasquier L (1981). Genetic control of T-helper cell function in the clawed toad *Xenopus laevis*. *Eur. J. Immunol.* 11, 151-155.

Bernard CCA, Bordmann G, Blomberg B & Du Pasquier L (1979). Immunogenic studies on the cell-mediated cytotoxicity in the clawed toad *Xenopus laevis*. Immunogenetics. 9, 443-454.

Bleicher PA & Cohen N (1981). Monoclonal anti-IgM can separate T cell from B cell proliferative responses in the frog, *Xenopus laevis*. J. Immunol. 127, 1549-1555.

Bleicher PA, Rollins-Smith LA, Jacobs DA & Cohen N (1983). Mitogenic responses of frog lymphocytes to crude and purified preparations of bacterial LPS. Devel. Comp. Immunol. 7, 483-496.

Blomberg B, Bernard C and Du Pasquier L (1980). *In vitro* evidence for T-B lymphocyte collaboration in the clawed toad *Xenopus*. Eur. J. Immunol. 10, 869-876.

Boom WH, Liano D & Abbas AK (1988). Heterogeneity of helper/inducer T lymphocytes. II Effects of IL-4 and IL-2 producing T cell clones on resting B lymphocytes. J. Exp. Med. 167, 1350-1363.

Boyer PD & Rothenberg EV (1988). IL-2 receptor inducibility is blocked in cortical-type thymocytes. J. Immunol. 140, 2886-2892.

Braakman E, Rotteveel FTM, Van Bleek G, Van Seventer GA & Lucas CJ (1987). Are MHC class II restricted cytotoxic T

lymphocytes important? Immunol. Today. 8, 265-267.

Brandhuber BJ, Boone T, Kenney WC, McKay DB (1987). Three-dimensional structure of interleukin-2. Science. 238, 1707-1709.

Cantrell DA & Smith KA (1983). Transient expression of interleukin 2 receptors: consequences for T cell growth. J. Exp. Med. 163, 1895-1911.

Caspi R & Avtalion R (1984). Evidence for the existence of an IL-2 like lymphocyte growth promoting factor in the bony fish, *Cyprinus carpio*. Devel. Comp. Immunol. 8, 51-60.

Ceredig R, Dialynas DP, Fitch FW & Robson MacDonald H (1983). Precursors of T cell growth factor producing cells in the thymus: Ontogeny, frequency and quantitative recovery in a subpopulation of phenotypically mature thymocytes defined by monoclonal antibody GK.15. J. Exp. Med. 158, 1654-1671.

Ceredig R, Lynch F & Newman P (1987). Phenotypic properties, interleukin 2 production, and developmental origin of a "mature" subpopulation of Lyt-2<sup>-</sup> L3T4<sup>-</sup> mouse thymocytes. P.N.A.S. (USA) 84, 8578-8582.

Cerretti DP, McKereghan K, Larsen A, Cantrell MA, Anderson D, Gillis S, Cosman D & Baker PE (1986). Cloning, sequence

and expression of bovine interleukin 2. P.N.A.S. (USA) 83, 3223-3227.

Cherwinski HM, Schumacher JH, Brown KD & Mosman TR (1987). Two types of mouse helper T cell clone. III. Further differences in lymphokine synthesis between Th 1 and Th 2 clones revealed by RNA hybridization, functionally monospecific bioassays, and monoclonal antibodies. J. Exp. Med. 1229-1244.

Chesnut RW, Colon SN & Grey HM (1982). Requirements for the processing of antigens by antigen-presenting B cells. I. Functional comparison of B cell tumours and macrophages. J. Immunol. 129, 2382-2388.

Cohen FE, Kosen PA, Kuntz ID, Epstein LB, Gardelli TL & Smith KA (1986). Structure-activity studies of interleukin-2. Science 234, 349-352.

Cohen N, Watkins D & Parsons SV (1987). Interleukin and T cell ontogeny in *Xenopus laevis*. Prog. Clin. Biol. Res. 253, 653-681.

Cohen N, Watkins D & Parsons SV (1987). Interleukins and T-cell ontogeny in *X.laevis*. In: Developmental and comparative immunology (Cooper EL, Langlet C & Bierne J, ed) AR Liss Inc., New York, pp53-68.

Collie MH (1974). The location of soluble antigen in the

spleen of *Xenopus laevis*. *Experientia* 30, 1205.

Crouse DA, Turpen JB & Sharp JG (1985). Thymic non-lymphoid cells. *Surv. Immunol. Res.* 4, 120-134.

Cuchens MA & Clem LW (1979). Phylogeny of lymphocyte heterogeneity. III. Mitogenic responses of reptilian lymphocytes. *Devel. Comp. Immunol.* 3, 287-297.

DiMarzo S & Cohen N (1982). An *in vivo* study of the ontogeny of alloreactivity in the frog, *Xenopus laevis*. *Immunology* 45, 39-48.

Dinarelli CA (1987). The biology of IL-1 and comparison to TNF. *Immunol. Letts.* 16, 227-232.

Di Sabato G (1982). Purification and initial characterisation of rat interleukin 2. *P.N.A.S. (USA)* 79, 3020-3023.

Donnelly N, Manning MJ & Cohen N (1976). Thymus dependency of lymphocyte subpopulations in *Xenopus laevis*. In: *Phylogeny of thymus and bone marrow*. (Wright RK & Cooper EL, ed) Elsevier/North Holland Press, Amsterdam. pp133-141.

Du Pasquier L & Miggiano VC (1973). The mixed leucocyte reaction in the toad, *Xenopus laevis*: a family study. *Transplant. Proc.* 4, 1457-1461.

Du Pasquier L, Chardonnens A & Miggiano VC (1975). A major histocompatibility complex in the toad *Xenopus* (Daudin). *Immunogenetics* 1, 482-494.

Du Pasquier L, Horton JD (1976). The effect of thymectomy on the mixed leucocyte reaction and phytohaemagglutinin responsiveness in the clawed toad *Xenopus laevis*. *Immunogenetics* 3, 105-112.

Du Pasquier L & Horton JD (1982). Restoration of antibody responsiveness in early thymectomised *Xenopus* by implantation of major histocompatibility complex mismatched larval thymus. *Eur. J. Immunol.* 12, 546-551.

Du Pasquier L & Wabl MR (1977). The ontogeny of lymphocyte diversity in anuran amphibians. *Cold Spring Harbor Symp. Quant. Biol.* 41, 771-779.

Du Pasquier L & Flajnik M (1987). *Xenopus* MHC class II antigens. Basel Institute for Immunology annual report, 47-48.

Du Pasquier L & Flajnik M (1986). Expression of *Xenopus* MHC classII molecules during ontogeny. Basel Institute for Immunology annual report, pp44.

Du Pasquier L, Schwager J & Flajnik M (1989). The immune system of *Xenopus*. *Ann. Rev. Immunol.* 7, 251-275.

El Ridi R, Wahby AF & Saad AH (1986). Characterisation of snake interleukin 2. *Devel. Comp. Immunol.* 10, 128.

Fainboim L & Festenstein H (1979). Non-HLA-D determinants detected by the micro-MLC test. *Trans. Proc.* 11, 700-703.

Farag MA & El Ridi R (1986). Proliferative responses of snake lymphocytes to concanavalin A. *Devel. Comp. Immunol.* 10, 561-569.

Farrant J, Clark JC, Lee H, Knight SC & O'Brien J (1980). Conditions for measuring DNA synthesis in PHA stimulated human lymphocytes in 20 $\mu$ l hanging drops with various cell concentrations and periods of culture. *J. Immunol. Meths.* 33, 301-312.

Flajnik M, Du Pasquier L, Cohen N (1985). Immune responses of thymus/lymphocyte embryonic chimeras: studies on tolerance and major histocompatibility complex restriction in *Xenopus*. *Eur. J. Immunol.* 15, 540-547.

Flajnik M, Kaufman JF, Riegert P & Du Pasquier (1984). Identification of class I major histocompatibility complex encoded molecules in the amphibian *Xenopus*. *Immunogenetics.* 20, 433-442.

Flajnik M, Hsu E, Kaufman J & Du Pasquier L (1988). Biochemistry, tissue distribution, and ontogeny of surface

molecules detected on *Xenopus* hemopoietic cells. In: Differentiation antigens in lymphohemopoietic tissues. (Miyasaka M & Trnka Z, eds) Marcel Dekker, New York, pp387-419.

Fujita T, Takaoka C, Matsui H & Taniguchi T (1983). Structure of the human interleukin 2 gene. P.N.A.S. (USA). 80, 7437-7441.

Gearing AJH (1985). Amphibian T cell growth factor. In: Peptide hormones as mediators in immunology and oncology, Serono symposia 19 (Hesch RD & Atkinson M, eds). Raven Press, New York, pp234.

Gearing AJH (1989). Cytokines. Thymus Update. 2, 127-143.

Gillis S & Watson J (1980). Biochemical and biological characterisation of lymphocyte regulatory molecules. V. Identification of an interleukin 2-producing human leukaemia cell line. J. Exp. Med. 152, 1709-1719.

Gillis S, Union NA, Baker PE & Smith KA (1979). The *in vitro* generation and sustained culture of nude mouse cytotoxic T lymphocytes. J. Exp. Med. 149, 1460-1476.

Goodacre JA, Simpson JM, Johnstone R & Robinson JH (1987). A limiting dilution assay to determine the frequency of antigen presenting cells. J Immunol. Meths. 103, 103-108.



Granelli-Piperno A, Vassalli J-D & Reich E (1981). Purification of murine T cell growth factor. *J. Exp. Med.* 154, 422-431.

Green-Donnelly N & Cohen N (1979). Phylogeny of immunocompetent cells: III. Mitogen response characteristics of lymphocyte subpopulations from normal and thymectomised frogs. *Cell. Immunol.* 46, 59-70.

Green J & Jotte R (1985). Interactions between T-helper cells and dendritic cells during the rat mixed lymphocyte reaction. *J. Exp. Med.* 162, 1546-1560.

Greaves MF, Bauminger S & Janossy G (1972). Lymphocyte activation: III. Binding sites for phytoimitogens on lymphocyte subpopulations. *Clin. Exp. Immunol.* 10 537-554.

Grimm EA & Rosenberg SA (1982). Production and properties of human IL-2. In: Isolation, characterization and utilization of T lymphocyte clones. Academic press Inc., pp57-82.

Guidos C, Sinha AA & Lee K-C (1987). Functional differences and complementation between dendritic cells and macrophages in T cell activation. *Immunology.* 61, 269-276.

Guidos C, Wong M & LE K-C (1984). A comparison of the stimulatory activities of lymphoid dendritic cells and

macrophages in T proliferative responses to various antigens. J. Immunol. 133, 1179-1184.

Gullberg M & Smith KA (1986). Regulation of T cell autocrine growth: T4+ cells become refractory to interleukin 2. J. Exp. Med. 163, 270-284.

Hadji-Azimi I, Schwager J & Thiebaud C (1982). B-lymphocyte differentiation in *Xenopus laevis* larvae. Devel. Biol. 90, 253-258.

Hadji-Azimi I & Schwager J (1980). *Xenopus laevis* larval thymocytes do not express surface immunoglobulin. Cell. Immunol. 53, 389-394.

Hagiwara H, Su Huang HJ, Arai N, Herzenberg LA, Arai KI & Zlotnik A (1987). Interleukin 1 modulates messenger RNA levels of lymphokines and of other molecules associated with T cell activation in the T cell lymphoma LB RM33-1A-. J. Immunol. 138, 2514-2519. Hamblin AS (1988). Lymphokines and interleukins. Immunol. supp. 1, 39-41.

Hamblin (1988). Lymphokines (Male D, ed) IRL Press, Oxford & Washington DC.

Hamby BA, Huggins Jr. EM, Lachman LB, Dinarello CA & Sigel MM (1986). Fish lymphocytes respond to human IL-1. Lymphokine Res. 5, 157-161.

Hashimoto N, Nabholz M, MacDonald HR & Zubler RH (1986). Dissociation of interleukin 2-dependent and independent B cell proliferation with monoclonal anti-interleukin 2 receptor antibody. *Eur. J. Immunol.* 16, 317-320.

Heeg K, Steeg C & Wagner H (1988). High dose irradiated splenic stimulator cells show no endogenous interleukin-2 production but stimulate clonally developing helper T cells to produce interleukin-2. *J. Immunol. Meths.* 109, 185-191.

Henderson L, Hewetson J, Hopkins R, Sowder R, Neubauer R & Rabin H (1983). A rapid large scale purification procedure for gibbon IL-2. *J. Immunol.* 131, 810-816.

Herzberg VL & Smith KA (1987). T cell growth without serum. 139, 998-1004.

Holbrook NJ, Smith KA, Fornace AJ, Comeau C, Wiskocil RL & Crabtree GR (1984). T-cell growth factor: complete nucleotide sequence and organization of the gene in normal and malignant cells. *P.N.A.S. (USA)* 81, 1634-1638.

Horton JD, Russ J, Aitchison P & Horton TL (1987). Thymocyte/stromal cell chimaerism in allothymus-grated *Xenopus*: developmental studies using the *X.borealis* fluorescence marker. *Development.* 100, 107-117.

Horton JD & Manning MJ (1974). Effect of early thymectomy

on the cellular changes occurring in the spleen of the clawed toad following administration of soluble antigen. Immunology. 26, 797.

Horton JD & Manning MJ (1972). Response to skin allografts in *Xenopus laevis* following thymectomy at early stages of lymphoid organ maturation. Transplantation. 14, 141-154.

Horton JD & Horton TL (1975). Development of transplantation immunity and restoration experiments in the thymectomised amphibian. Amer. Zool. 15, 73-84.

Horton JD & Sherif NEHS (1977). Sequential thymectomy in the clawed toad: effect on mixed leucocyte reaction and PHA responsiveness. In: Developmental Immunobiology (Solomon JB & Horton JD, eds). Elsevier/North-Holland Biomedical Press, Amsterdam. pp 283-290.

Horton JD, Horton TL, Varley CA & Ruben LN (1989). Attempts to break perimetamorphically induced skin graft tolerance by treatment of *Xenopus* with cyclophosphamide and IL-2. Transplantation. 47, 883-887.

Horton JD, Smith AR, Williams NH, Smith A & Sherif NEHS (1980). Lymphocyte reactivity to "T" and "B" cell mitogens in *Xenopus laevis*: Studies on thymus and spleen. Devel. Comp. Immunol. 4, 75-86.

Horton TL, Horton JD & Varley CA (1989). *In vitro*

cytotoxicity in adult *Xenopus* generated against larval targets and minor histocompatibility antigens. Transplantation. 47, 880-882.

Horton JD & Lackie A (1989). Evolution of immunity. In: Immunology (Roitt I, Brostoff J & Male D, eds) Gower Medical Publishing, London, New York, pp 15.1-15.12.

Hunig T & Bevan MJ (1980). Specificity of cytotoxic T cells from athymic mice. J. Exp. Med. 152, 688-702.

Inaba K, Witmer MD & Steinman RM (1984). Clustering of dendritic cells, helper T lymphocytes and histocompatible B cells during primary antibody responses *in vitro*. J. Exp. Med. 160, 858-874.

Inaba K & Steinman RM (1986). Accessory cell-T lymphocyte interactions: antigen-dependent and independent clustering. 163, 247-261.

Inaba K & Steinman RM (1984). Resting and sensitized T lymphocytes exhibit distinct stimulatory (antigen-presenting cell) requirements for growth and lymphokine release. J. Exp. Med. 160, 1717-1735.

Jelinek DF & Lipsky PE (1987). Regulation of human B lymphocyte activation, proliferation, and differentiation. Adv. Immunol. 40, 1-59.

Jung LKL, Hara T & Man Fu S (1984). Detection and functional studies of p60-65 (TAC antigen) on activated human B cells. *J. Exp. Med.* 160, 1597-1602.

Karasuyama H, Rolink A & Melchers F (1988). Recombinant IL-2 or 5, but not 3 or 4, induces maturation of resting mouse B lymphocytes and propagates proliferation of activated B cell blasts. *J. Exp. Med.* 167, 1377-1390.

Kashima N, Nishi-Takaoka C, Fujita T, Taki S, Yamada G, Hamuro J & Taniguchi T (1985). Unique structure of murine interleukin-2 as deduced from cloned cDNAs. *Nature.* 313, 402-404.

Katagiri C (1978). *Xenopus laevis* as a model for the study of immunobiology. *Devel. Comp. Immunol.* 2, 5-14.

Katagiri C & Tochinal (1987). Ontogeny of thymus-dependent immune responses and lymphoid cell differentiation. *Devel. Growth & Differ.* 29, 297-305.

Kaye C & Tompkins R (1983). Allograft rejection in *Xenopus laevis* following larval thymectomy. *Devel. Comp. Immunol.* 7, 287-294.

Kaufman JF, Flajnik MF, Du Pasquier L & Riegert P (1985). *Xenopus* MHC class II molecules. I. Identification and structural characterisation. *J. Immunol.* 134, 3248-3257.

Killar L, MacDonald G, West J, Woods A & Bottomly K (1987). Cloned, Ia-restricted T cells that do not produce interleukin 4/B cell stimulatory factor 1 (BSF-1) fail to help antigen-specific B cells. *J. Immunol.* 138, 1674-1679.

Klaus GGB, Humphrey JH, Kunkl A & Dongworth DW (1980). The follicular dendritic cell: its role in antigen presentation in the generation of immunological memory. *Immunol. Rev.* 53, 3-28.

Klein JR & Bevan MJ (1983). Secretion of immune interferon and generation of cytotoxic T cell activity in nude mice are dependent on interleukin 2: age associated endogenous production of interleukin 2 in nude mice. *J. Immunol.* 130, 1780-1783.

Kline K & Sanders BG (1980). Developmental profile of chicken splenic lymphocyte responsiveness to Con A and PHA and studies on chicken splenic and bone marrow cells capable of inhibiting mitogen-stimulated blastogenic responses of adult splenic lymphoblasts. *J. Immunol.* 125, 1792-1797.

Kobel HR & Du Pasquier L (1975). Production of large clones of histocompatible fully identical cloned toads (*Xenopus*). *Immunogenetics.* 20, 443-451.

Landgraf B, Cohen FE, Smith KA, Gadski R & Ciardelli TL (1989). Structural significance of the c-terminal

amphiphilic helix of interleukin-2. J. Biol. Chem. 264, 816-822.

Langeberg L, Ruben LN, Malley A, Shiigi S & Beadling C (1986/87). Toad splenocytes bind human IL-2 and anti-human IL-2 receptor antibody specifically. Immunol. Letts. 14, 103-110.

Langeberg L, Ruben LN, Clothier RH & Shiigi S (1987). The characterization of the toad splenocytes which bind mouse anti-human IL-2 receptor antibody. Immunol. Letts. 16, 43-48.

Le J & Vilcek J (1987). Biology of disease. TNF and IL-1: Cytokines with multiple overlapping biological activities. Lab. Invest. 56, 234-248.

Lechler RI & Batchelor JR (1982). Restoration of immunogenicity to passenger cell-depleted kidney allografts by the addition of donor strain dendritic cells. J. Exp. Med. 155, 31-41.

Loveland B, Hunt R & Malkovsky M (1986). Autologous lymphoid cells exposed to recombinant interleukin-2 *in vitro* in the absence of antigen can induce the rejection of long-term tolerated skin allografts. Immunology. 59, 159-161.

MacDonald HR, Lees RK, Glasebrook AL & Sordat B (1982).



Interleukin 2 production by lymphoid cells from congenitally athymic (nu/nu) mice. J. Immunol. 129, 521-525.

MacDonald HR & Lees RK (1984). Frequency and specificity of precursors of interleukin 2-producing cells in nude mice. J. Immunol. 132, 605-610.

Malkovsky M & Medawar PB (1984). Is immunological tolerance (non-responsiveness) a consequence of IL-2 deficit during the recognition of antigen. Immunol. Today. 5, 340-343.

Malissen B, Peele-Price M, Goverman JM, McMilan M, White J, Kappler J, Marrack P, Pierres M & Hood L (1984). Gene transfer of H-2 class II genes: antigen presentation by mouse fibroblast and hamster B-cell lines. Cell. 36, 319-327.

Manning MJ, Donnelly N & Cohen N (1976). Thymus-dependent and thymus-independent components of the amphibian immune system. In: Phylogeny of thymus and bone marrow (Wright RK & Cooper EL, eds). Elsevier/North Holland, Biomedical Press, Amsterdam, pp 123-132.

Manning MJ (1971). The effect of early thymectomy on histogenesis of the lymphoid organs in *Xenopus laevis*. J. Embryol. Exp. Morph. 26, 219.

Manning MJ & Collie MH (1977). The ontogeny of thymic dependence in the amphibian *Xenopus laevis*. In: Developmental Immunobiology (Solomon JB & Horton JD, eds) Elsevier/North Holland, Biomedical Press, Amsterdam, pp 291-298.

Melchers F, Andersson J, Lernhardt W & Schrier MH (1980). H-2-unrestricted polyclonal maturation without replication of small B cells induced by antigen-activated T cell help factors. Eur. J. Immunol. 10, 679-685.

Mier J & Gallo R (1982). The purification and properties of human T cell growth factor. J. Immunol. 128, 112-1127.

Mughal MS (1984). Immunological memory in young fish and amphibians: studies on *Cyprinus carpio*, *Chelon labrosus* and *Xenopus laevis*. Ph.D. thesis, Polytechnic South-West.

Muraguchi A, Kehrl JH, Longo DL, Volkman DJ, Smith KA & Fauci AS (1985). Interleukin 2 receptors on human B cells: Implications for the role of interleukin 2 in human B cell function. J. Exp. Med. 161, 181-197.

Nagata S & Katagiri C (1978). Lymphocyte surface immunoglobulin in *Xenopus laevis* light and electron microscopic demonstration by immunoperoxidase method. Devel. Comp. Immunol. 2, 277-286.

Nagata S & Cohen N (1983). Specific *in vivo* and non-

specific *in vitro* alloreactivities of adult frogs (*Xenopus laevis*) that were thymectomised during early larval life. Eur. J. Immunol. 13, 541-545.

Nagata S (1985). A cell surface marker of thymus-dependent lymphocytes in *Xenopus laevis* is identifiable by mouse monoclonal antibody. Eur. J. Immunol. 15, 837-841.

Nagata S (1986a). Development of T lymphocytes in *Xenopus laevis*: Appearance of the antigen recognised by an anti-thymocyte mouse monoclonal antibody. Devel. Biol. 114, 389-394.

Nagata S (1986b). T cell proliferative responses of *Xenopus* lymphocyte subpopulations separated on anti-thymocyte monoclonal antibody coupled to sepharose beads. Devel. Comp. Immunol. 10, 259-264.

Nagata S (1988). T cell-specific antigen in *Xenopus* identified with a mouse monoclonal antibody: Biochemical characterization and species distribution. Zool. Science. 5, 77-83.

Nakagawa T, Hirano T, Nakagawa N, Yoshizaki K & Kishimoto T (1985). Effect of recombinant IL-2 and gamma-IFN on proliferation and differentiation of human B cells. J. Immunol. 134, 959-966.

Nakamura T, Sekizawa A, Fujii T & Katagiri C (1986).

Cosegregation of the polymorphic C4 with the MHC in the frog *Xenopus laevis*. Immunogenetics. 23, 181-186.

Nakanishi K, Malek TR, Smith KA, Hamaoka T, Shevach EM & Paul WE (1984). Both interleukin 2 and a second T cell-derived factor in EL-4 supernatant have activity as differentiation factors in IgM synthesis. J. Exp. Med. 160, 1605-1621.

Nishimura T, Kozutsumi H & Hashimoto Y (1984). Mitogenic effect of IL-2 on non-thymic and thymic lymphocytes of the mouse. Thymus 6, 225-233.

Nieu<sup>w</sup>koop PD & Faber J (1967). Normal table of *Xenopus laevis* (Daudin). North Holland, Amsterdam.

O'Brien J, Knight S, Quick NA, Moore EH & Platt AS (1979). A simple technique for harvesting lymphocytes cultured in Terasaki plates. J. Immunol. Meths. 27, 219-223.

Odling KA, Halliday GM & Muller HK (1987). Enhanced survival of skin grafts depleted of Langerhans cells by treatment with dimethylbenzanthracene. Immunology. 62, 379-385.

Pfizenmaier K, Scheurich P, Daubener W, Kronke M, Rollinghoff M & Wagner H (1984). Quantitative representative of all T cells committed to develop into cytotoxic effector cells and/or interleukin 2 activity-

producing helper cells within murine T lymphocyte subsets.  
Eur. J. Immunol. 14, 33-39.

Prakash S, Robb RJ, Stout RD & Parker DC (1985). Induction of high affinity IL 2 receptors on B cells responding to anti-Ig and T cell derived helper factors. J. Immunol. 135, 117-122.

Puré E, Isakson PC, Takatsu K, Hamaoka T, Swain SL, Dutton RW, Dennert G, Uhr JW & Vitetta (1981). Induction of B cell differentiation by T cell factors 1. Stimulation of IgM secretion by products of a T cell hybridoma and a T cell line. J. Immunol. 127, 1953-1958.

Puré E, Inaba K & Metlay J (1988). Lymphokine production by murine T cells in the mixed leucocyte reaction. J. Exp. Med. 168, 795-800.

Reeves R, Spies AG, Nissen MS, Buck CD, Weinberg AD, Barr PJ, Magnusson & Magnuson JA (1986). Molecular cloning of a functional bovine interleukin 2 cDNA. P.N.A.S. (USA) 83, 3228-3232.

Reynolds DS, Boom WH & Abbas (1987). Inhibition of B lymphocyte activation by interferon-gamma. J. Immunol. 139, 767-773.

Riendeau D, Delsworth G, Harnish G, Bleakley R & Paetkau V (1983). Purification of mouse interleukin 2 to apparent

homogeneity. J. Biol. Chem. 258, 1214-1217.

Roitt I, Brostoff J & Male D (1989). In: Immunology. Gower Medical Publishing Ltd. London.

Rollins-Smith L, Parsons S & Cohen N (1984). During frog ontogeny, PHA and Con A responsiveness of splenocytes precedes that of thymocytes. Immunology 52, 491-500.

Rollinghoff M, Pfizenmaier K & Wagner H (1982). T-T interaction during cytotoxic T cell responses. IV. Murine lymphoid dendritic cells are powerful stimulators for helper T lymphocytes. Eur. J. Immunol. 12, 337-842.

Rothenberg EV (1989). The long road to functional maturity for developing T cells. Immunol. Today. 10, 116-117.

Rothenberg EV, McGuire KL & Boyer PD (1988). Molecular indices of functional competence in developing T cells. Immunol. Revs. 104, 29-52.

Ruben LN, Clothier R & Balls M (1985). Murine and human IL-2 can substitute for the thymus in immune responses to TNP-Ficoll in *Xenopus laevis* the South African clawed toad. Cell. Immunol. 93, 229-233.

Ruben LN (1986). Recombinant DNA produced human IL-2, injected *in vivo*, will substitute for carrier priming of helper function in the South African clawed toad, *Xenopus*

*laevis*. Immunol. Letts. 13, 227-230.

Ruben LN, Clothier RH, Mirchandani M, Wood P & Balls M (1987). Signals provided *in vivo* by human rIL-2 and Con A can switch hapten-specific tolerance from unresponsiveness to responsiveness in the South African clawed toad. Immunology 61, 235-241.

Ruben LN, Langeberg I, Lee R, Clothier RH, Malley A, Hostenstein C & Shiigi S (1989). An example of the conservation of IL-2 and its receptor. UCLA symposia, in press.

Ruben LN, Clothier RH, Murphy GL, Marshall JD, Lee R, Pham T, Nobis C & Shiigi S (1989). Thyroid function and immune reactivity during metamorphosis in *Xenopus laevis*, the South African clawed toad. Gen. Comp. Endocrin. 76, 128-138.

Ruben LN, Clothier RH, Horton JD & Balls M (1989). Amphibian metamorphosis: an immunologic opportunity! BioEssays 10, 7-12.

Schauenstein K, Globerson A & Wick G (1982). Avian lymphokines: 1. Thymic cell growth factor in SNs of mitogen stimulated chicken spleen cells. Devel. Comp. Immunol. 6, 533-540.

Schauenstein K & Kromer G (1987). In: Avian Immunology:

basis and practice vol1. (Toivanen A & Toivanen P, eds)  
CRC Press, Boca Raton, Fla, pp213-227.

Schauenstein K, Kromer G, Hala K, Bock G & Wick G (1988).  
Chicken-activated-T-lymphocyte-antigen (CATLA) recognized  
by monoclonal antibody INN-CH16 represents the IL-2  
receptor. *Devel. Comp. Immunol.* 12, 823-831.

Schnetzler M, Dommen A, Nowak JS & Franklin RM (1983).  
Characterisation of chicken T cell growth factor. *Eur. J.*  
*Immunol.* 13, 560-566.

Schwager J & Hadji-Azimi I (1984). Mitogen-induced B-cell  
differentiation in *Xenopus laevis*. *Differentiation* 27,  
182-188.

Schwager J & Hadji-Azimi I (1985). Anti-immunoglobulin M  
induces both B-lymphocyte proliferation and  
differentiation in *Xenopus laevis*. *Differentiation* 30, 29-  
34.

Scollay R, Bartlett P & Shortman K (1984). T cell  
development in the adult murine thymus: changes in the  
expression of the surface antigens Ly2, L3T4 & B2A2 during  
development from early precursor cells to emigrants.  
*Immunol. Revs.* 82, 79-103.

Secombes CJ (1987). Lymphokine-release from rainbow trout  
leucocytes stimulated with Concanavalin A. Effects upon



macrophage spreading and adherence. *Devel. Comp. Immunol.* 11, 513-520.

Shapiro HM (1988) In: *Practical flow cytometry*, 2<sup>nd</sup> edition. Alan R. Liss Inc., New York.

Seiss DC, Magnuson NS & Reeves R (1989). Characterization of the bovine receptor(s) for interleukin-2. *Immunology* 68, 190-195.

Shimonkevitz R, Kappler J, Marrack P & Grey H (1983). Antigen recognition by H-2-restricted T cells. I. Cell-free antigen processing. *J. Exp. Med.* 158, 303-316.

Silvers WK, Kimura H, Desquenne-Clark L & Miyamoto M (1987). Some new perspectives on transplantation tolerance. *Immunol. Today.* 8, 185-190.

Smith KA, Favat MF & Oroszlan (1983). Production and characterisation of monoclonal antibodies to human interleukin-2: strategy and tactics. *J. Immunol.* 131, 1808-1815.

Smith KA (1988a). Interleukin-2: Inception, impact and implications. *Science.* 240, 1169-1176.

Smith KA (1988b). The bimolecular structure of the interleukin-2 receptor. *Immunol. Today.* 9, 36-37.

Steinman RM (1981). Dendritic cells. Transplantation 31, 151.

Steinman RM, Gutchinov B, Witmer MD & Nussenzweig MC (1983). Dendritic cells are the principle stimulators of the primary mixed leucocyte reaction in mice. J. Exp. Med. 157, 613-627.

Sunshine GH, Katz DR & Czitrom AA (1982). Heterogeneity of stimulator cells in the murine MLR. Eur. J. Immunol. 12, 9.

Sunshine GH, Katz DR & Feldman M (1980). Dendritic cells induce T cell proliferation to synthetic antigens under Ir gene control. J. Exp. Med. 152, 1817.

Taniguchi T, Matsui H, Fujita T, Takaoka C, Kashima N, Yoshimoto R & Hamura J (1983). Structure and expression of a cloned cDNA for human interleukin-2. Nature 302, 305-310.

Tempelis CH, Hala K, Kromer G, Schauenstein K & Wick G (1988). Failure to alter neonatal transplantation tolerance by the injection of interleukin 2. Transplantation 45, 449-451.

Teshigawara K, Wang HM, Kato K & Smith KA (1987). Interleukin 2 high-affinity receptor expression requires two distinct binding proteins. J. Exp. Med. 165, 223-238.

Thuy LTB, Dukovich M, Peffer NJ, Fauci AS, Kehrl JH & Greene WC (1987). Direct activation of human resting T cells by IL-2: The role of an IL-2 receptor distinct from the Tac protein. *J. Immunol.* 139, 1550-1556.

Thiebaud CH (1983). A reliable new cell marker in *Xenopus*. *Devel. Biol.* 98, 245-249.

Tochinai S & Katagiri C (1975). Complete abrogation of immune response to skin allografts and rabbit erythrocytes in the early thymectomised *Xenopus*. *Devel. Growth & Differ.* 17, 383-394.

Tochinai S, Nagata S & Katagiri C (1976). Restoration of immune responsiveness in early thymectomised *Xenopus* by implantation of histocompatible adult thymus. *Eur. J. Immunol.* 6, 711-714.

Trinchieri G & Perussia B (1985). Immune interferon: a pleiotropic lymphokine with multiple effects. *Immunol. Today.* 6, 131-136.

Tsuda M, Uchiyama T & Uchino H (1984). Expression of Tac antigen on activated normal human B cells. *J. Exp. Med.* 160, 612-617.

Tsuda M, Goldman CK, Bongiovanni KF, Chan WC, Winton EF, Yagita M, Grimm EA & Waldmann TA (1987). The p75 peptide

is the receptor for interleukin 2 expressed on large granular lymphocytes and is responsible for the interleukin 2 activation of these cells. P.N.A.S. (USA). 84, 5394-5398.

Tsuda M, Kozak RW, Goldman CK & Waldman TA (1986). Demonstration of a non-Tac peptide that binds interleukin 2: A potential participant in a multichain interleukin 2 receptor complex. P.N.A.S. (USA) 83, 9694-9698.

Turpen JB & Smith PB (1986). Analysis of hemopoietic lineage of accessory cells in the developing thymus of *Xenopus laevis*. J. Immunol. 136, 412-421.

Turpen JB, Cohen N, Deparis P, Jaylet A, Tompkins R & Volpe EP (1982). Ontogeny of hemopoietic cells. In: the reticuloendothelial system (Cohen N & Sigel MM, eds). Plenum Publishing Co., New York, pp 569-589.

Uchiyama T, Broder S, Waldman TA (1981). A monoclonal antibody (anti-Tac) reactive with activated and functionally mature human T cells. J. Immunol. 126, 1393-1397.

Varley CA (1990). T cells and transplantation tolerance in thymectomised *Xenopus* implanted with foreign thymus. Ph.D thesis, University of Durham.

Vainio O, Ratcliffe MJH & Leanderson T (1986). Chicken T

cell growth factor: Use in the generation of long term cultured T cell line and biochemical characterisation. Scand. J. Immunol. 23, 135-142.

Wagner H, Hardt C, Heeg K, Rollinghoff M & Pfizenmaier K (1980). T cell derived helper factor allows *in vivo* induction of cytotoxic T cells in nu/nu mice. Nature 284, 278-280.

Walden P, Nagy ZA & Klein J (1985). Induction of regulatory T-lymphocyte responses by liposomes carrying major histocompatibility complex molecules and foreign antigen. Nature 315, 327-329.

Wang H-M & Smith KA (1987). The interleukin 2 receptor: Functional consequences of its bimolecular structure. J. Exp. Med. 166, 1055-1069.

Watkins D & Cohen N (1985). The phylogeny of interleukin-2. Devel. Comp. Immunol. 9, 819-824.

Watkins D, Parsons SV & Cohen N (1988). The ontogeny of interleukin production and responsivity in the frog *Xenopus*. Thymus 11, 113-122.

Watkins D & Cohen N (1987). Mitogen-activated *Xenopus laevis* lymphocytes produce a T cell growth factor. Immunology 62, 119-125.

Watkins D, Parsons SV & Cohen N (1987). A factor with IL-1 like activity is produced by peritoneal cells from the frog *Xenopus laevis*. *Immunology* 62, 669-673.

Watkins D (1985) T-cell function in *Xenopus*. Ph.D. thesis, Rochester University, New York.

Weiss N & Du Pasquier L (1973). Factors affecting the reactivity of amphibian lymphocytes in a miniaturised technique of the mixed lymphocyte culture. *J. Immunol. Meths.* 3, 273-286.

Weiss N, Horton JD & Du Pasquier L (1973). The effect of thymectomy on cell surface associated and serum immunoglobulin in the toad, *Xenopus laevis* (Daudin): A possible inhibitory role of the thymus on the expression of immunoglobulins. In: *Phylogenetic and ontogenetic study of the immune response and its contribution to the immunological theory.* (Liacopoulis P & Panijel J, eds) INSERM, Paris, pp 165-174.

Williams NH & Horton JD (1980). Ontogeny of mitogen responsiveness in thymus and spleen of *Xenopus laevis*. In: *Aspects of Developmental and Comparative Immunology I* (Solomon JB, ed) Pergamon Press, Oxford & New York, pp 493-494.

Williams NH, Cribbin FA, Zettergren LD & Horton JD (1983). Ontogeny and characterisation of mitogen-reactive

lymphocytes in the thymus and spleen of the amphibian, *Xenopus laevis*. Immunology 49, 301-309.

Wright RK & Cooper EL (1978). Leopard frog (*Rana pipiens*) spleen lymphocyte responses to plant lectins. Kinetics and carbohydrate inhibition. Devel. Comp. Immunol. 2, 95-108.

Zubler RH, Lowenthal JW, Erard F, Hashimoto N, Devos R & MacDonald (1984). Activated B cells express receptors for, and proliferate in response to, pure interleukin 2. J. Exp. Med. 160, 1170-1183.

## APPENDIX

### Phosphate buffered saline

N.B. 10 times mammalian strength (dilute 1/15 for amphibian use)

#### PER LITRE

|  |        |
|--|--------|
| NaCl                                       | 80.0g  |
| KCl  | 2.0g   |
| Na <sub>2</sub> HPO <sub>4</sub> anhydrous | 11.35g |
| KH <sub>2</sub> PO <sub>4</sub>            | 2.0g   |

Dissolve in just under 1000mls, make up to almost 1000mls, pH the solution (pH 7.2-7.4) and make up to 1000mls. This solution can be autoclaved.

### Amphibian ringer

#### TO MAKE 1 LITRE

|                                  |                         |
|----------------------------------|-------------------------|
| NaCl                             | 6.6g                    |
| KCl                              | 0.15g                   |
| CaCl <sub>2</sub>                | 1.35ml (if in solution) |
| Na <sub>2</sub> HCO <sub>3</sub> | 0.3g                    |

Dissolve in just less than 1000mls. When the salts have dissolved pH the solution and make the volume up to



1000mls (1 litre).

5:3 medium

TO MAKE 80MLS

|                                   |        |
|-----------------------------------|--------|
| Leibovitz-15                      | 50mls  |
| Double distilled H <sub>2</sub> O | 30mls  |
| HEPES buffer                      | 0.8mls |

Filter medium through 0.2 $\mu$ m filter.