



Durham E-Theses

New amine-substituted cyclopentadienyl and indenyl ligands

Marsh, Sarah Margaret Beatrice

How to cite:

Marsh, Sarah Margaret Beatrice (1997) *New amine-substituted cyclopentadienyl and indenyl ligands*, Durham theses, Durham University. Available at Durham E-Theses Online: <http://etheses.dur.ac.uk/5012/>

Use policy

The full-text may be used and/or reproduced, and given to third parties in any format or medium, without prior permission or charge, for personal research or study, educational, or not-for-profit purposes provided that:

- a full bibliographic reference is made to the original source
- a [link](#) is made to the metadata record in Durham E-Theses
- the full-text is not changed in any way

The full-text must not be sold in any format or medium without the formal permission of the copyright holders.

Please consult the [full Durham E-Theses policy](#) for further details.

New Amine-Substituted Cyclopentadienyl and Indenyl Ligands

Thesis submitted in part fulfilment of the degree of Doctor of Philosophy

Sarah Margaret Beatrice Marsh

Trevelyan College

January 1997

The copyright of this thesis rests with the author. No quotation from it should be published without the written consent of the author and information derived from it should be acknowledged.



- 3 JUL 1997

"O Lord, you have searched me and you know me.

You know when I sit and when I rise, you perceive my thought from afar.

Before a word is on my tongue you know it completely, O Lord.

Search me, O God, and know my heart; test me and know my anxious thoughts.

See if there is any offensive way in me, and lead me in the way everlasting"

- Psalm 139: 1- 2, 4, 23- 24

This work is dedicated to the One who searched me out, who found me and guided me when I was lost, and whose strength is made perfect in my weakness.

This work was carried out at the University of Durham, department of Chemistry, between October 1993 and December 1996. The material described in this thesis is all my own work, except where otherwise stated, and has not been submitted as part of any other degree at this or any other University. The copywrite of this thesis rests with the author. No quotation from it should be published without her prior, written consent, and information derived from it should be acknowledged.

Acknowledgements

First of all I would like to thank my supervisors Dr A. K. Hughes and Prof. K. Wade for all their help and encouragement throughout this project, and the University of Durham for a studentship. I would also like to thank Dr M. Kilner and Prof. V. C. Gibson for all their help with equipment and lab space during the early stages of this work.

On the technical side, I must thank Ray Hart and Gordon Haswell for all their help and expertise with glassblowing, and especially for joining up hundreds of NMR tubes. I would like to thank Mr Brian Hall for his help with various aspects of this work, particularly for keeping CG 104 running smoothly despite the rest of us, and for standardising all those bottles of BuLi. I would like to thank Prof. R. K. Harris and his group, especially Lindsay Crowe, for help with running and interpreting solid-state NMR spectra; Dr Alan Kenwright and Mrs Julia Say for running 400MHz, 2-dimensional and DEPT NMR experiments; Dr M. Jones and Miss L. M. Turner for mass spectra; Mrs J. Dostal and Miss J. Magee for elemental analysis; and Prof. J. A. K. Howard and Mr Peter Ford for X-ray crystallography. I would also like to thank Dr Hugh MacBride for his very useful advice on some aspects of this work, particularly the organic synthesis. I would like to thank Dr A. K. Hughes, Rev. G. J. Marsh and all the various others who proof-read this work. Any remaining mistakes are entirely mine.

I would like to give a heart-felt thanks to all the various people I have shared various labs with. Especially I would like to say a massive thanks to Andrew Kingsley and Brian Bridgewater for putting up with me in the lab and generally being really great people to work with. I would also like to thank the others in CG 108 and the hangers-on for all those lardy lunches and for not being even remotely strange or bizarre people: Pat Gemmell, Marky Roden, Andy Johnson, Graham Robertson, Lynn Boyd, Tom Hibbert and all the rest. Especially I want to thank Caragh McCausland for her friendship and support without which this last year would have been very difficult indeed.

Outside of work I wish to thank Gail Phillip, Beth Hartland and Rachel Carrington for their friendship, Ingrid Sharp for giving me a roof over my head and for her support during the final stages of my writing up and Rebecca Canning for all her friendship and support during some really difficult times, and for helping me to keep my priorities straight, especially regarding the relative importance of work and Star Trek. Finally I would like to thank all at Grad Soc Bible Study group for their friendship and for some really good discussions, and Father, Son and Spirit for inspiration, support and a few genuine miracles, of which this thesis is one.

Abbreviations

The following abbreviations will be used throughout this thesis:

| | |
|-------------------|--|
| ⁿ Bu | ⁿ Butyl group, C ₄ H ₉ |
| ^t Bu | ^t Butyl group, C(CH ₃) ₃ |
| COSY | CORrelation SpectroscopY |
| CpH | Cyclopentadiene, C ₅ H ₆ |
| Cp [*] H | Pentamethyl cyclopentadiene, C ₅ (CH ₃) ₅ H |
| DEPT | Distortionless Enhancement by Polarisation Transfer |
| DME | 1,2-Dimethoxyethane, CH ₃ OCH ₂ CH ₂ OCH ₃ |
| DMSO | Dimethyl Sulphoxide, (CH ₃) ₂ SO |
| Et | Ethyl group, C ₂ H ₅ |
| GC-MS | Gas Chromatography - Mass Spectroscopy |
| HETCOR | HETeronuclear CORrelation |
| IR | Infra-Red spectroscopy |
| LDA | Lithium diisopropyl amide, Li[N ⁱ Pr ₂] |
| MAO | Methyl Aluminoxane, [AlOMe] _n |
| MAS | Magic Angle Spinning |
| Me | Methyl group, CH ₃ |
| NMR | Nuclear Magnetic Resonance spectroscopy |
| Ph | Phenyl group, C ₆ H ₅ |
| ⁱ Pr | Isopropyl group, CH(CH ₃) ₂ |
| Py | Pyridine, C ₅ H ₅ N |
| THF | Tetrahydrofuran, C ₄ H ₈ O |
| TMEDA | N,N,N',N'-Tetramethylethylenediamine, (CH ₃) ₂ NCH ₂ CH ₂ N(CH ₃) ₂ |

Abbreviations used in describing IR and NMR spectra:

| | | | | | |
|---|---------|------|---------|----|-----------|
| s | singlet | q | quartet | m | multiplet |
| d | doublet | quin | quintet | br | broad |
| t | triplet | sept | septet | | |

Abstract: New Amine-Substituted Cyclopentadienyl and Indenyl Ligands

Sarah M. B. Marsh

Submitted for the degree of PhD

January 1997

University of Durham

This thesis concerns the new amine-substituted cyclopentadiene and indene ligands $C_5H_5(CH_2)_3N(tBu)H$ and $C_9H_7(CH_2)_3N(tBu)H$ which can co-ordinate to a metal through all five carbon atoms of the five-membered ring (η^5) and/ or through the nitrogen (σ). Chapter 1 reviews the recent literature concerning Lewis-base functionalised cyclopentadienyl and indenyl ligands and their compounds with s-, p-, d- and f-block metals.

Chapter 2 contains a brief review of possible synthetic routes to amine-substituted cyclopentadienyl and indenyl ligands with some examples from the recent literature, and a detailed account of the synthesis of $C_5H_5(CH_2)_3N(tBu)H$ and $C_9H_7(CH_2)_3N(tBu)H$. The amino alcohol $tBuNH(CH_2)_3OH$ was synthesised by the conjugate addition of $tBuNH_2$ to ethyl acrylate and reduction of the product ester $tBuNH(CH_2)_2CO_2Et$ using $LiAlH_4$. $tBuNH(CH_2)_3OH$ was converted into $tBuNH(CH_2)_3Br.HBr$ and $tBuNH(CH_2)_3Cl.HCl$ by reaction with HBr or $SOCl_2$. Reaction between $tBuNH(CH_2)_3Cl.HCl$ and two equivalents of $Na(C_5H_5)$ gave $C_5H_5(CH_2)_3N(tBu)H$ in good yield. Treatment of $tBuNH(CH_2)_3Cl.HCl$ with excess $NaOH$ followed by reaction with $Li(C_9H_7)$ gave $C_9H_7(CH_2)_3N(tBu)H$, also in good yield.

Chapter 3 describes the synthesis of various main group and iron compounds of $C_5H_5(CH_2)_3N(tBu)H$ and $C_9H_7(CH_2)_3N(tBu)H$. Lithium salts $Li[C_5H_4(CH_2)_3N(tBu)H]$, $Li[C_5H_4(CH_2)_3N(tBu)]Li$, $Li[C_9H_6(CH_2)_3N(tBu)H]$ and $Li[C_9H_6(CH_2)_3N(tBu)]Li$ were prepared for use as reactive intermediates and $Li[C_5H_4(CH_2)_3N(tBu)H]$ was characterised as its THF-adduct by 1H NMR spectroscopy. The silyl derivatives $(Me_3Si)C_5H_4(CH_2)_3NH^tBu$ and $(Me_3Si)C_5H_4(CH_2)_3N(tBu)SiMe_3$ were synthesised and characterised by NMR

spectroscopy, and $(\text{Me}_3\text{Si})\text{C}_9\text{H}_6(\text{CH}_2)_3\text{N}(\text{tBu})\text{H}$ and $(\text{Me}_3\text{Si})\text{C}_9\text{H}_6(\text{CH}_2)_3\text{N}(\text{tBu})(\text{SiMe}_3)$ were also synthesised. The amine-substituted ferrocene $\text{Fe}\{\eta^5\text{-C}_5\text{H}_4(\text{CH}_2)_3\text{N}(\text{tBu})\text{H}\}_2$ was synthesised and oxidised to the corresponding ferricenium ion which was isolated as its PF_6^- salt. Exploratory work was carried out into the preparation of heterobimetallic species by reaction between $\text{Fe}\{\eta^5\text{-C}_5\text{H}_4(\text{CH}_2)_3\text{N}(\text{tBu})\text{H}\}_2$ and MX_2 ($\text{M} = \text{Co}, \text{Ni}, \text{X} = \text{Cl}; \text{M} = \text{Mn}, \text{X} = \text{Br}$). The substituted bis(indenyl) iron(II) complex $\text{Fe}\{\eta^5\text{-C}_9\text{H}_6(\text{CH}_2)_3\text{N}(\text{tBu})\text{H}\}_2$ was also synthesised.

Chapter 4 is an account of the chemistry of $\{\eta^5\text{-}\sigma\text{-C}_5\text{H}_4(\text{CH}_2)_3\text{N}(\text{tBu})\}\text{Ti}(\text{NMe}_2)_2$ which was synthesised by an aminolysis reaction between $\text{C}_5\text{H}_5(\text{CH}_2)_3\text{NH}(\text{tBu})$ and $\text{Ti}(\text{NMe}_2)_4$. Reaction between this compound and various weak acids gave a range of new compounds including

$\{\eta^5\text{-}\sigma\text{-C}_5\text{H}_4(\text{CH}_2)_3\text{N}(\text{tBu})\}\text{Ti}(\text{O}^i\text{Pr})_2$, $\{\eta^5\text{-}\sigma\text{-C}_5\text{H}_4(\text{CH}_2)_3\text{N}(\text{tBu})\}\text{Ti}(\text{S}^i\text{Bu})_2$,
 $\{\eta^5\text{-}\sigma\text{-C}_5\text{H}_4(\text{CH}_2)_3\text{N}(\text{tBu})\}\text{Ti}(\text{C}_5\text{H}_5)(\text{NMe}_2)$, $\{\eta^5\text{-}\sigma\text{-C}_5\text{H}_4(\text{CH}_2)_3\text{N}(\text{tBu})\}\text{Ti}(\text{SnBu}_3)_2$ and the imido-bridged dimer $[\{\eta^5\text{-}\sigma\text{-C}_5\text{H}_4(\text{CH}_2)_3\text{N}(\text{tBu})\}\text{Ti}(\text{NHPh})]_2(\mu\text{-NPh})_2$, the X-ray structure of which is reported.

Chapter 5 describes the experimental procedures used, and chapter 6 gives lists of characterising data for each compound. Appendix A gives details of the methods used for magnetic susceptibility determinations; appendix B lists X-ray crystallographic data for $[\{\eta^5\text{-}\sigma\text{-C}_5\text{H}_4(\text{CH}_2)_3\text{N}(\text{tBu})\}\text{Ti}(\text{NHPh})]_2(\mu\text{-NPh})_2$ and appendix C lists departmental colloquia attended.

Table of Contents

| | |
|--|----|
| <u>Chapter 1: Literature Survey</u> | 1 |
| 1.1: Background | 2 |
| 1.2: Reasons for Study | 3 |
| 1.3: s- and p-Block Compounds | 5 |
| 1.4: Early Transition Metal Chemistry | 11 |
| 1.5: Late Transition Metal Chemistry | 25 |
| 1.6: Lanthanides | 34 |
| 1.7: Conclusions | 36 |
| 1.8: References | 37 |
| <u>Chapter 2: Ligand Synthesis</u> | 42 |
| 2.1: Introduction | 43 |
| 2.2: Overview of Ligand Synthesis | 48 |
| 2.3: Ethyl 3-Tertiarybutylamino Propionate (2.1) | 49 |
| 2.4: Variation of the N-Substituent | 52 |
| 2.5: Introduction of Substituents into the Carbon Backbone | 55 |
| 2.6: 3-Tertiarybutylamino Propan-1-ol (2.2) | 57 |
| 2.7: 3-Tertiarybutylamino-1-Bromopropane Hydrobromide (2.3) | 58 |
| 2.8: 3-Tertiarybutylamino-1-Chloropropane Hydrochloride (2.4) | 61 |
| 2.9: N-Tertiarybutylamino Propylcyclopentadiene (2.7) | 67 |
| 2.10: N-Tertiarybutylaminopropyl-2-Indene (2.8) | 70 |

| | |
|---|-----|
| 2.11: Conclusion | 74 |
| 2.12: References | 75 |
| <u>Chapter 3: Synthesis of some Main Group and Iron Compounds</u> | 77 |
| 3.1: Introduction | 78 |
| 3.2: Alkali Metal Compounds | 78 |
| 3.3: Trialkylsilyl Derivatives | 83 |
| 3.4: Other Main Group Compounds | 87 |
| 3.5: Amine-Substituted Ferrocenes | 89 |
| 3.6: Heterobimetallic Compounds | 101 |
| 3.7: Conclusion | 108 |
| 3.8: References | 110 |
| <u>Chapter 4: Synthesis of Group 4 Complexes of Amine-Substituted Cyclopentadienyl and Indenyl Ligands by Aminolysis Reactions</u> | 112 |
| 4.1: Background | 113 |
| 4.2: Group 4 Amide Complexes of <u>2.7</u> and <u>2.8</u> | 113 |
| 4.3: Attempted Conversion of Amide Complexes <u>4.1</u> and <u>4.2</u> into Halides | 123 |
| 4.4: Attempted Preparation of Group 4 Halide complexes of <u>2.7</u> | 124 |
| 4.5: Aminolysis Reaction of <u>4.1</u> | 127 |
| 4.6: Reaction Between <u>4.1</u> and Aniline | 138 |
| 4.7: Reaction Between <u>4.1</u> and Small Molecules Containing Multiple Bonds | 150 |
| 4.8: Conclusion | 156 |

| | |
|--|-----|
| 4.9: References | 157 |
| <u>Chapter 5: Experimental</u> | 159 |
| 5.1: General Information and Starting Materials | 160 |
| 5.2: Experimental for Chapter 2 | 166 |
| 5.3: Experimental for Chapter 3 | 172 |
| 5.4: Experimental for Chapter 4 | 178 |
| 5.5: References | 183 |
| <u>Chapter 6: Characterising Data</u> | 184 |
| 6.1: Data for Chapter 2 | 185 |
| 6.2: Data for Chapter 3 | 193 |
| 6.3: Data for Chapter 4 | 202 |
| <u>Appendix A: Magnetic Susceptibility Determinations</u> | 214 |
| <u>Appendix B: X-ray Crystallographic Data for Compound 4.8</u> | 218 |
| <u>Appendix C: Departmental Colloquia Attended</u> | 226 |

List of Figures

Chapter 1:

| | |
|---|----|
| Fig. 1.2.1: Some of the possible co-ordination modes of heteroatom functionalised cyclopentadienyl ligands | 4 |
| Fig. 1.3.1: Lithium salts of Lewis-base functionalised cyclopentadienide anions | 6 |
| Fig. 1.3.2 Potassium Lithium salts of Lewis-base functionalised cyclopentadienide anions | 6 |
| Fig. 1.3.3: Grignard chemistry of dimethylaminoethyl tetramethylcyclopentadiene | 7 |
| Fig. 1.3.4: Calcium salt of a Lewis-base substituted tetramethylcyclopentadienide anion | 8 |
| Fig. 1.3.5: Group 13 complexes of amino-alkyl substituted cyclopentadienyl and tetramethylcyclopentadienyl ligands | 9 |
| Fig. 1.3.6: Group 14 complexes of a Lewis-base substituted cyclopentadienyl ligand | 10 |
| Fig. 1.4.1: Scandium complexes of the $Cp^*SiMe_2N^tBu$ ligand | 12 |
| Fig. 1.4.2: Chemistry of the dimethylethylamino cyclopentadienyl ligand with group 4 metals | 14 |
| Fig. 1.4.3: Half-sandwich titanium dimethylaminoethyl cyclopentadienyl complex with intramolecularly co-ordinated nitrogen | 15 |
| Fig. 1.4.4: Cyclopentadienyl ligands bearing cyclic amine-substituents | 15 |

| | |
|--|----|
| Fig. 1.4.5: Amine-substituted cyclopentadienyl ligands with SiMe₂ spacer units | 16 |
| Fig. 1.4.6: Tridentate functionalised cyclopentadienyl ligands | 17 |
| Fig. 1.4.7: Amine-substituted zirconocenes | 18 |
| Fig. 1.4.8: Zirconocene complexes of 1-dimethylamino indenyl ligands | 18 |
| Fig. 1.4.9: Group 4 complexes of a methylaminopropyl cyclopentadienyl ligand | 19 |
| Fig. 1.4.10: Bidentate alkoxide complex <i>via</i> intramolecular C-O activation | 20 |
| Fig. 1.4.11: Complexes of 2-methoxyethyl and 3-methoxypropyl cyclopentadienyl ligands | 20 |
| Fig. 1.4.12: Chiral alkoxide-substituted fluorenyl ligand | 21 |
| Fig. 1.4.13: Other donor-functionalised group 4 complexes | 21 |
| Fig. 1.4.14: Group 5 and 6 complexes of CpSiMe₂NR | 22 |
| Fig. 1.4.15: Linked cyclopentadienyl-imido complex of Nb | 23 |
| Fig 1.4.16: Mo complexes of the dimethylethylamino cyclopentadienyl ligand | 24 |
| Fig 1.5.1: Mn complexes of an amine-substituted cyclopentadienyl ligand | 25 |
| Fig. 1.5.2: Ferrocene-type complexes of functionalised cyclopentadienyl ligands | 26 |
| Fig. 1.5.3: Iron(II) complex with an intramolecularly co-ordinated functionalised cyclopentadienyl ligand | 27 |

| | |
|---|----|
| Fig. 1.5.4: Co, Rh, and Ir complexes of an amine-substituted cyclopentadienyl ligand | 28 |
| Fig. 1.5.5: Cobalt(III) complexes of an amine-substituted cyclopentadienyl ligand | 29 |
| Fig. 1.5.6: Co complexes of a but-3-enyl cyclopentadienyl ligand | 30 |
| Fig. 1.5.7: Attempted catalytic trimerisation of alkynes using a cobalt complex of an alkene-substituted cyclopentadienyl ligand | 31 |
| Fig. 1.5.8: Rh and Ir complexes of the $C_5H_4(CH_2)_2PPh_2$ ligand | 32 |
| Fig. 1.5.9: Group 10 complexes of the dimethylethylamino tetramethylcyclopentadienyl ligand | 33 |
| Fig. 1.6.1: Iodide and tetrafluoroborate complexes of lanthanides | 34 |
| Fig. 1.6.2: Tris(cyclopentadienyl) complexes of lanthanides | 35 |
| Fig. 1.6.3: Homoleptic ytterbocene (II) complexes | 35 |
| <u>Chapter 2:</u> | |
| Fig. 2.1.1: Synthesis of a Lewis-base substituted peralkylated cyclopentadiene | 43 |
| Fig. 2.1.2: Routes to pentafulvenes | 44 |
| Fig. 2.1.3: Introduction of substituents into pentafulvenes by nucleophilic attack | 45 |
| Fig. 2.1.4: Phosphine and amine functionalised cyclopentadienes | 46 |
| Fig. 2.1.5: Vinyl-substituted metal cyclopentadienyls from a fulvene | 47 |
| Fig. 2.1.6: Synthesis of a pyridyl-functionalised tetramethylcyclopentadiene | 47 |

| | |
|--|----|
| Fig. 2.1.7: A substituted indene <i>via</i> a fulvene intermediate | 48 |
| Fig. 2.2.1: Ligand synthesis | 49 |
| Fig. 2.3.2: Addition of a primary amine to ethyl acrylate | 50 |
| Fig. 2.3.3: Alternative synthesis of N-alkyl-3-hydroxypropylamine | 51 |
| Fig. 2.3.4: Formation of an undesirable side-product | 51 |
| Fig. 2.4.1: Unsuccessful reaction between ethyl acrylate and phenylamine | 53 |
| Fig. 2.4.2: Proposed route to N-phenylaminopropyl cyclopentadiene | 54 |
| Fig. 2.4.3: Reaction between ethylenediamine and ethyl acrylate | 54 |
| Fig. 2.5.1 Reaction between amides and ethyl-<i>trans</i>-cinnamate | 55 |
| Fig. 2.5.2: Reaction between malonic acid, benzaldehyde and ammonia | 56 |
| Fig. 2.5.3: Reaction between amines, methacrylates and crotonates | 57 |
| Fig. 2.7.1: 2-Dialkylamino-1-bromoethane hydrobromide | 59 |
| Fig. 2.7.2: IR spectrum of <u>2.3</u> | 60 |
| Fig. 2.8.1: Formation of N-^tbutyl azetidine side-product | 63 |
| Fig. 2.8.2: The ¹H NMR of <u>2.4</u> contaminated with <u>2.6</u> | 64 |
| Fig. 2.8.3: The ¹H NMR spectrum of pure <u>2.4</u> | 65 |
| Fig. 2.8.4: The ¹³C{¹H} NMR spectrum of pure <u>2.4</u> | 66 |
| Fig. 2.9.1: The ¹H NMR spectrum of <u>2.7</u> | 69 |
| Fig. 2.10.1: Amine-substituted indene <u>2.8</u> | 71 |
| Fig. 2.10.2: The ¹H NMR spectrum of <u>2.8</u> | 72 |
| Fig. 2.10.3: The ¹³C{¹H} NMR spectrum of <u>2.8</u> | 73 |

Chapter 3

| | |
|---|-----|
| Fig. 3.2.1: Mono-deprotonation of <u>2.7</u> with ⁿBuLi in hexanes | 79 |
| Fig. 3.2.2: Synthesis of the di-lithium salt, <u>3.2</u> | 81 |
| Fig. 3.2.3: Synthesis of mono- and di-lithium indenides, <u>3.3</u> and <u>3.4</u> | 82 |
| Fig. 3.2.4: Synthesis of the potassium cyclopentadienide <u>3.5</u> | 83 |
| Fig. 3.3.1: Synthesis of the trimethylsilyl derivative <u>3.6</u> | 84 |
| Fig. 3.3.2: Preparation of the bis(trimethylsilyl) derivative <u>3.7</u> | 86 |
| Fig. 3.3.3: Synthesis of trimethylsilyl derivatives of <u>2.8</u> | 87 |
| Fig. 3.3.4: Grignard reagents derived from <u>2.7</u> | 88 |
| Fig. 3.5.1: Synthesis of the amine-substituted ferrocene <u>3.12</u> | 90 |
| Fig. 3.5.2: The ¹H NMR spectrum of <u>3.12</u> | 91 |
| Fig. 3.5.3: The ¹³C{¹H} NMR spectrum of <u>3.12</u> | 92 |
| Fig. 3.5.4: IR spectra of <u>3.12</u> and [<u>3.13</u>][PF₆] | 94 |
| Fig. 3.5.5: Oxidation of <u>3.12</u> to [<u>3.13</u>]⁺ | 95 |
| Fig. 3.5.6: Synthesis of <u>3.14</u> | 96 |
| Fig. 3.5.7: The ¹³C{¹H} NMR spectrum of <u>3.14</u> | 98 |
| Fig. 3.5.8: Coupled ¹³C NMR spectrum of <u>3.14</u> | 99 |
| Fig. 3.5.9: DEPT spectrum of <u>3.14</u> | 100 |
| Fig. 3.6.1: Heterobimetallic complexes based on the C₅H₅PPh₂ ligand | 102 |
| Fig. 3.6.2: Heterobimetallics based on the C₅H₅SiMe₂CH₂PPh₂ ligand | 102 |
| Fig. 3.6.3: Heterobimetallic complexes of group 4 metallocene dichlorides of C₅H₅(CH₂)₂PPh₂ | 103 |
| Fig. 3.6.4: Fe-Ru heterobimetallics | 104 |
| Fig. 3.6.5: Heterobimetallic based on a pyridyl-functionalised ferrocene | 104 |

| | |
|--|-----|
| Fig. 3.6.6: Reaction between <u>3.12</u> and MX_2 | 106 |
| Fig. 3.6.7: IR spectrum of <u>3.15</u> | 107 |
| <u>Chapter 4:</u> | |
| Fig. 4.2.1: Preparation of <u>4.1</u> and <u>4.2</u> | 115 |
| Fig. 4.2.2: The ^1H NMR spectrum of <u>4.1</u> | 116 |
| Fig. 4.2.3: The $^{13}\text{C}\{^1\text{H}\}$ NMR spectrum of <u>4.1</u> | 117 |
| Fig. 4.2.4: The ^1H NMR spectrum of <u>4.1a</u> | 119 |
| Fig. 4.2.5: The $^{13}\text{C}\{^1\text{H}\}$ NMR spectrum of <u>4.1a</u> | 120 |
| Fig. 4.2.6: Proposed rearrangement of <u>4.1</u> and <u>4.2</u> on heating | 121 |
| Fig. 4.2.7: Reaction between <u>2.8</u> and $\text{Zr}(\text{NMe}_2)_4$ | 122 |
| Fig. 4.3.1: Potential conversion of group 4 amides to halides | 124 |
| Fig. 4.4.1: Preparation of group 4 complexes <i>via</i> lithiated and silylated cyclopentadiene derivatives | 125 |
| Fig. 4.4.2: Proposed route to Ti chloride complexes of <u>2.7</u> | 126 |
| Fig. 4.5.1: Reactions between group 4 amide complexes and weak acids | 127 |
| Fig. 4.5.2: The ^1H NMR spectrum of <u>4.4</u> | 129 |
| Fig. 4.5.3: The $^{13}\text{C}\{^1\text{H}\}$ NMR spectrum of <u>4.4</u> | 130 |
| Fig. 4.5.4: Reaction between <u>4.1</u> and propan-2-ol | 131 |
| Fig. 4.5.5: The ^1H NMR spectrum of <u>4.5</u> | 132 |
| Fig. 4.5.6: The $^{13}\text{C}\{^1\text{H}\}$ NMR spectrum of <u>4.5</u> | 133 |
| Fig. 4.5.7: Reaction between <u>4.1</u> and $^t\text{BuSH}$ | 134 |
| Fig. 4.5.8: Reaction between <u>4.1</u> and C_5H_6 | 135 |

| | |
|--|-----|
| Fig. 4.5.9: Reaction between <u>4.1</u> and Bu₃SnH | 136 |
| Fig. 4.6.1: Reaction between <u>4.1</u> and aniline | 139 |
| Fig. 4.6.2: X-ray structure of <u>4.8</u> | 140 |
| Fig. 4.6.3: The ¹H NMR spectrum of <u>4.8</u> | 143 |
| Fig. 4.6.4: The ¹³C{¹H} NMR spectrum of <u>4.8</u> | 144 |
| Fig. 4.6.5: The ¹H COSY of <u>4.8</u> | 146 |
| Fig. 4.6.6: The ¹H-¹³C HETCOR of <u>4.8</u> | 147 |
| Fig. 4.6.7: Proposed dissociation of <u>4.8</u> in solution | 148 |
| Fig. 4.6.8: Solid-state ¹³C{¹H} NMR spectrum of <u>4.8</u> | 149 |
| Fig. 4.7.1: Possible reaction between <u>4.1</u> and CO₂ | 151 |
| Fig. 4.7.2: Solid-state ¹³C{¹H} NMR spectrum of <u>4.10</u> | 152 |
| Fig. 4.7.3: Solid-state ¹⁵N NMR spectrum of <u>4.10</u> | 153 |
| Fig. 4.7.4: Proposed reaction between <u>4.1</u> and CS₂ | 154 |
| <u>Chapter 5:</u> | |
| Fig. 5.1.1: Apparatus for liberating Me₂NH from aqueous solution | 162 |
| Fig. 5.1.2: Apparatus for sublimation of Zr(NMe₂)₄ | 165 |

CHAPTER 1

Survey of Recent Literature Concerning Lewis-Base Functionalised Cyclopentadienyl Ligands



1.1: Background to this project

Cyclopentadiene and its substituted derivatives (such as pentamethyl cyclopentadiene, $C_5(CH_3)_5H$, also known as Cp^*H) are among the most important ligands in organometallic chemistry.¹ The organometallic chemistry of CpH , Cp^*H and other simple cyclopentadienes has been extensively investigated, and at this time some 80% of known organometallic species contain some form of cyclopentadienyl ligand. The steric properties of metal cyclopentadienyl complexes can be tailored by the introduction of up to five substituents,² and alkyl or silyl substituted cyclopentadienes can be used to stabilise highly reactive metal ligand fragments.^{2a} Cyclopentadienyl complexes are also very important in catalysis. Group 4 metallocenes dominate homogeneous Ziegler-Natta catalysis for the polymerisation of ethylene and propylene,³ and group 4 half-sandwich complexes are widely used for the polymerisation of styrene.⁴

Two major lines of research currently dominate metal-cyclopentadienyl chemistry. The first concerns the synthesis of linked bis-(cyclopentadiene)⁵ or bis-(indene)⁶ species which can then be co-ordinated to a metal to form *ansa*-metallocenes. This area is being investigated particularly with regard to the synthesis of defined stereochemistry and chiral metal complexes which can be used as catalysts for important stereospecific reactions, including alkene hydrogenations, alkene epoxidations, imine and ketone reductions, alkene isomerisations and alkene polymerisations.⁷ The second line of research concerns cyclopentadiene ligands with a functionalised side chain containing a donor atom, usually N, O or P. It is this second area with which this project is concerned, and the rest of this chapter will concentrate on reviewing the literature in this area.

1.2: Donor-Functionalised Cyclopentadienyl Ligands: Reasons for Study

Donor-functionalised cyclopentadiene ligands are important in organometallic chemistry for a variety of reasons. They can co-ordinate to a metal centre in several different ways, some of which are shown in figure 1.2.1. Complexes can be synthesised where the ligand is co-ordinated to the metal through the cyclopentadienyl ring only, leaving the functionalised side-chain pendant. The ligand can also co-ordinate intramolecularly through both the ring and the donor atom, essentially acting as a bidentate chelating ligand, or the ligand can co-ordinate to one metal through the ring and to a second metal (either the same or different) through the donor atom, giving oligo- or heterometallic species.

Heteroatom-functionalised cyclopentadienyl ligands combine the properties of their constituent moieties. This thesis is particularly concerned with amine-functionalised cyclopentadienyl ligands, which (according to the definition of Pearson⁸) contain both a hard donor (the amine nitrogen) and a soft donor (the cyclopentadienyl ring). This is expected to have a profound effect on the reactivity of metal complexes of these ligands, especially in early transition metal chemistry where the metals themselves are strongly Lewis-acidic and the co-ordination of a Lewis-base to the metal centre would potentially affect the structure and reactivity of complexes. In particular we wished to investigate the effect on the structure and reactivity of familiar bis(cyclopentadienyl) metal complexes when one cyclopentadienyl ligand, which is a monoanionic 5 electron ligand, is replaced by an alternative species such as an amide, NR_2^- , which is a monanionic 1 or 3 electron ligand.⁹ Such a change is expected to have dramatic effects on both the steric and electronic properties of the metal complexes, and hence on their structures and reactivities. Intramolecular co-ordination of the ligand is also expected to have a dramatic effect on the

catalytic activity and selectivity of these complexes in reactions such as alkene hydroboration¹⁰ and Ziegler-Natta polymerisation.¹¹

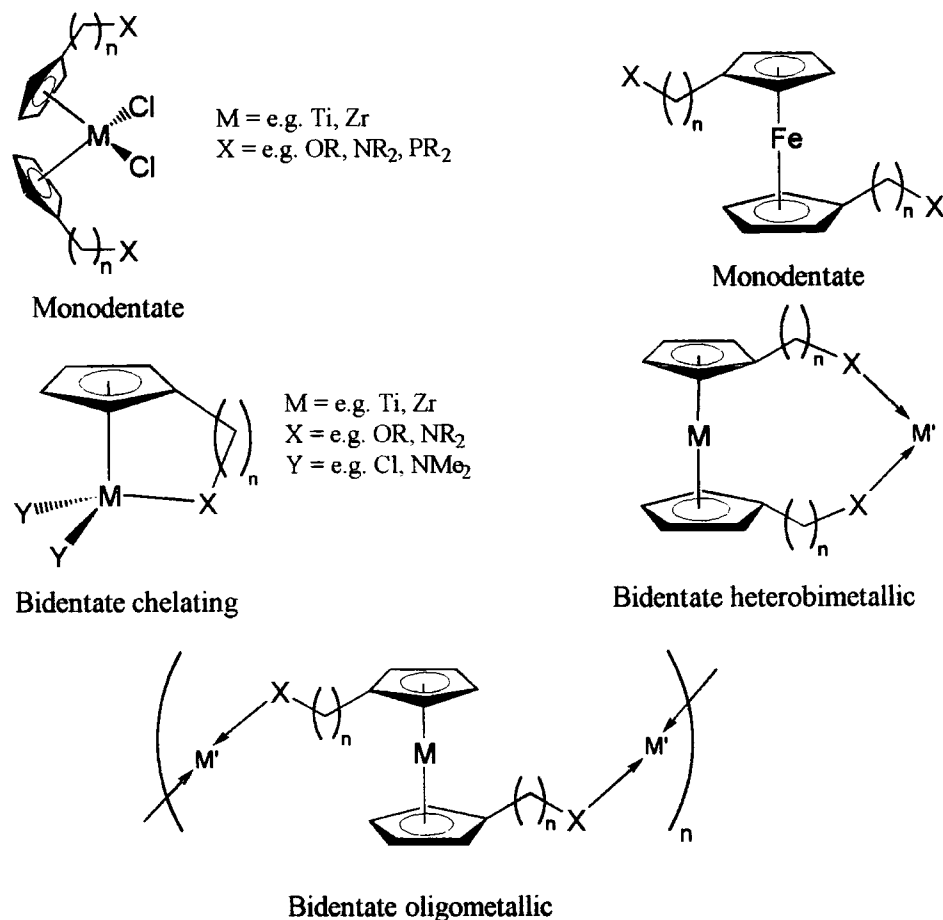

Figure 1.2.1: Some of the possible co-ordination modes of heteroatom functionalised cyclopentadienyl ligands

These types of functionalised cyclopentadienyl ligands are also interesting because they do not always act as innocent spectator ligands in the way that cyclopentadienyl usually does. They are frequently hemilabile,¹² since the heteroatom donor can sometimes be replaced by other ligands yet is always available to re-coordinate to the metal because it is tethered to the cyclopentadienyl ring. Again, this is expected to influence the reactivities of

such metal complexes. It also means that these ligands have proved useful for stabilising highly reactive metal-ligand fragments, and this will be discussed in more detail, with examples, later in this chapter.

Finally, in complexes where the ligand is co-ordinated through the cyclopentadienyl ring only, the presence of the heteroatom functionalised substituent chain can greatly influence the solubility of these complexes, giving rise to the possibility of carrying out organometallic chemistry in a variety of unusual solvents, including water.¹³ The heteroatom side chain can also be used to anchor the species to a surface, which could prove useful in catalytic applications.

1.3: s- and p- Block Compounds

1.3.1: Group 1

Alkali metal complexes of this type of ligand have chiefly been prepared for use as intermediates in the preparation of other metal complexes. Consequently, while there are many examples in the literature, particularly of lithium compounds, to our knowledge none have been fully characterised. Lithium compounds, such as that shown in figure 1.3.1, have been widely used for the preparation of a variety of complexes of different metals including Al, Ga, In,¹⁴ Si, Sn,¹⁵ Ge,¹⁶ Rh, Ir,¹⁷ Ni, Pd, Pt.¹⁸ Other examples of similar lithiated species have been used to prepare ferrocene-type compounds.¹⁹

Potassium salts of Lewis-base functionalised cyclopentadienes are also fairly common in the literature, and some examples are shown in figure 1.3.2. They are chiefly used in the preparation of lanthanide compounds,²⁰ though they have also been used to prepare titanium complexes of the 2-methoxyethyl cyclopentadiene shown in figure 1.3.2.²¹

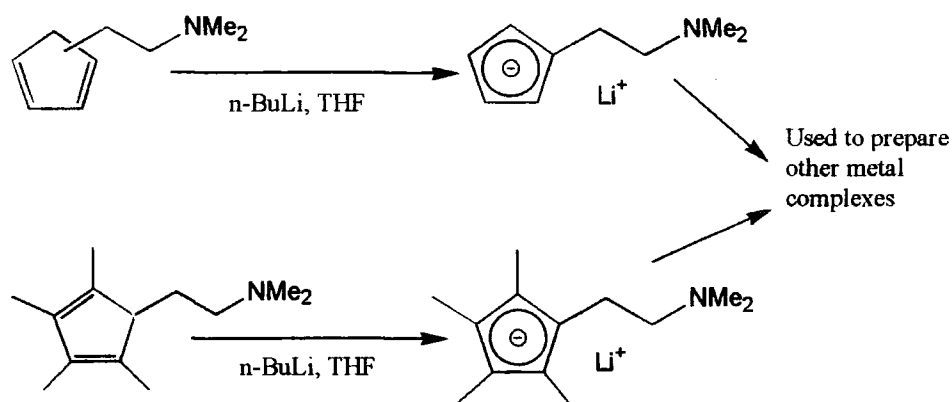

Figure 1.3.1: Lithium salts of Lewis-base functionalised cyclopentadienide anions

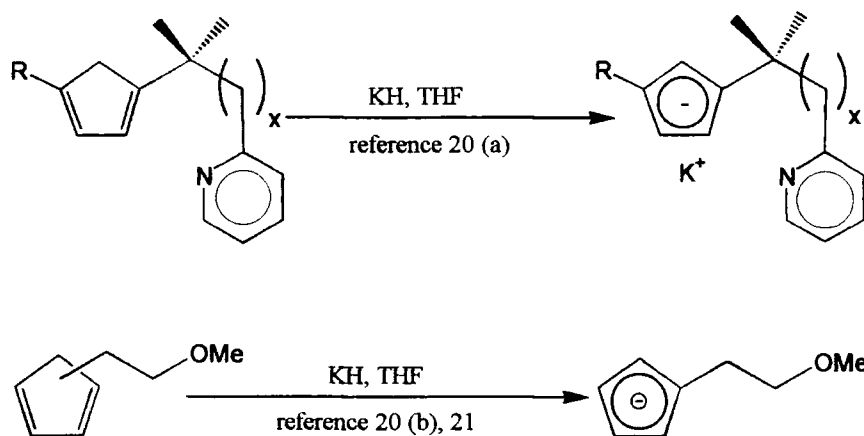

Figure 1.3.2: Potassium salts of Lewis-base functionalised cyclopentadienide anions

1.3.2: Group 2

The Grignard reagent prepared from dimethylaminoethyl tetramethyl cyclopentadiene has been made, and is shown in figure 1.3.3.²² It forms as a halogen-bridged dimer when isolated from non-polar solvents such as ether, and addition of THF causes the dimer to break apart giving a monomeric species with THF co-ordinated to the metal centre. X-ray crystal structures of both the dimer and the THF-substituted monomer are given in reference 22.

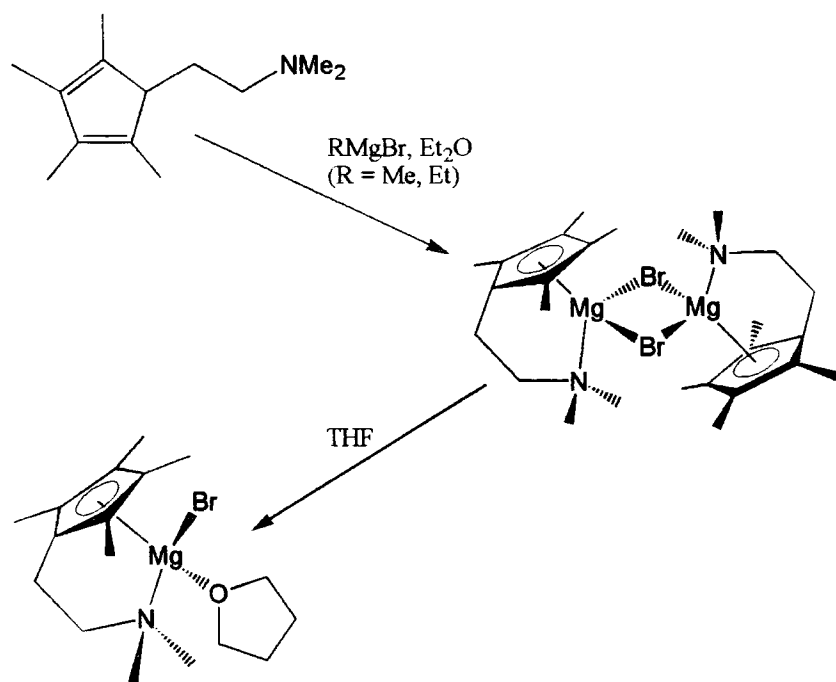

Figure 1.3.3: Grignard chemistry of dimethylaminoethyl tetramethylcyclopentadiene

The bis(cyclopentadienyl) calcium salt of dimethylaminoethyl tetramethylcyclopentadiene has also been made, and is shown in figure 1.3.4.²³ A feature of compounds of this particular ligand with metals of groups 2, 13 and some group 14 elements is that the ligand is co-ordinated intramolecularly. This is thought to be due to a pronounced chelate effect, and these compounds are generally found to be considerably more air-stable than their cyclopentadienyl analogues.

Bariocene analogues have been made of ligands of the type $(C_5H_4)CH_2CH_2R$ where $R = OMe, OEt, CH_2OEt, NMe_2$ and $OCH_2CH_2OCH_3$.²⁴ Although to our knowledge these compounds have not been characterised by X-ray crystallography, there is evidence for intramolecular co-ordination of the Lewis-base to the metal centre, giving rise to increased stability compared to bis(cyclopentadienyl) barium.

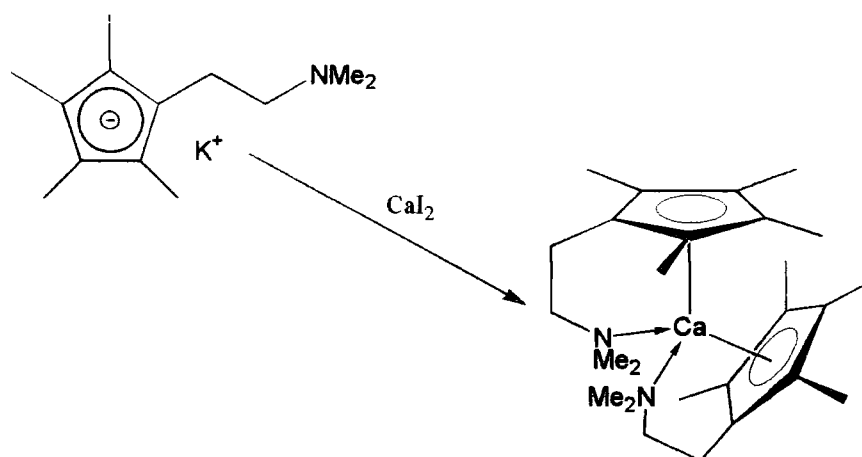

Figure 1.3.4: Calcium salt of a Lewis-base substituted tetramethylcyclopentadienyl anion

1.3.3: Group 13

Group 13 complexes of the dimethylaminoethyl cyclopentadienyl ligand and its tetramethyl cyclopentadienyl analogues have been extensively investigated by Jutzi and co-workers, and are summarised in figure 1.3.5.

Di-alkyl aluminium²⁵ and gallium²⁶ complexes have been shown by X-ray crystallography to have η^1 -co-ordination of the cyclopentadienyl ring and intramolecular co-ordination of the amine nitrogen, as do di-halo aluminium, gallium and indium complexes.²⁷ A mono-cyclopentadienyl thallium complex has also been made and unlike Al, Ga and In complexes shows η^5 -co-ordination of the cyclopentadienyl ring and no intramolecular co-ordination of the amine nitrogen.²⁸ It is noticeable that all except the mono-cyclopentadienyl thallium complex show intramolecular co-ordination of the amine nitrogen, and are described as having significantly increased stability to oxygen and water due to the stabilising effect of intramolecular co-ordination of the Lewis-base to the central atom.

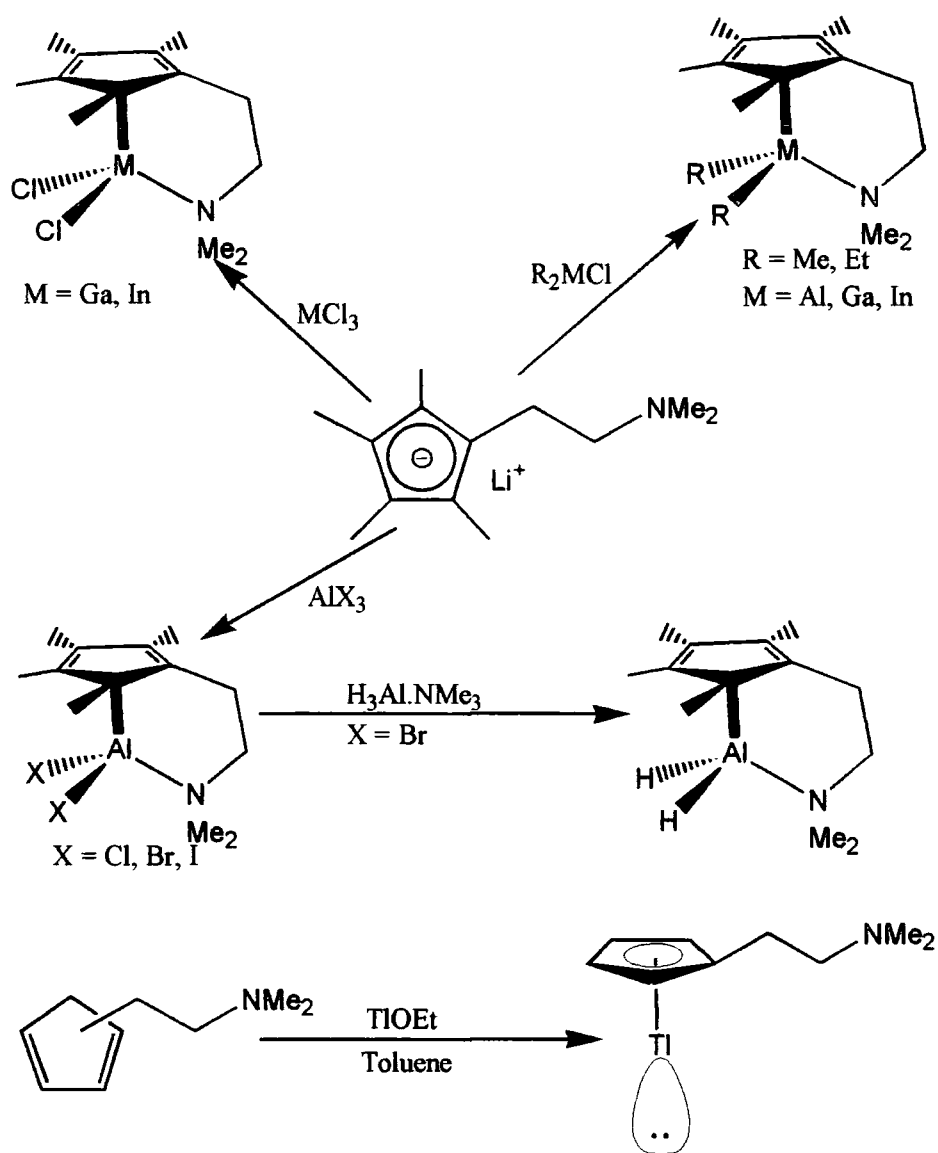

Figure 1.3.5: Group 13 complexes of amino-alkyl substituted cyclopentadienyl and tetramethylcyclopentadienyl ligands

1.3.4: Group 14 Compounds

Trimethylsilyl-derivatives of these types of ligand have been made, mainly for use in the preparation of transition metal complexes.²⁹ Both the trimethylsilyl- and trimethyltin-derivatives of the dimethylaminoethyl cyclopentadienyl ligand have been made, where the

ligand is attached to the metal through one carbon atom of the ring only, i.e. η^1 -coordination. A germanium (II) complex has also been made,³⁰ and like the group 2 and 13 complexes already discussed, the ligand is co-ordinated to the metal centre both through the cyclopentadienyl ring (with η^2 -co-ordination proposed on the basis of X-ray crystallographic evidence) and intramolecularly through the amine nitrogen, as shown in figure 1.3.6. As in the cases of groups 2 and 13 there is evidence of a pronounced chelate effect in this system, and the intramolecularly co-ordinated Lewis base attached to the metal centre has a considerable stabilising effect.

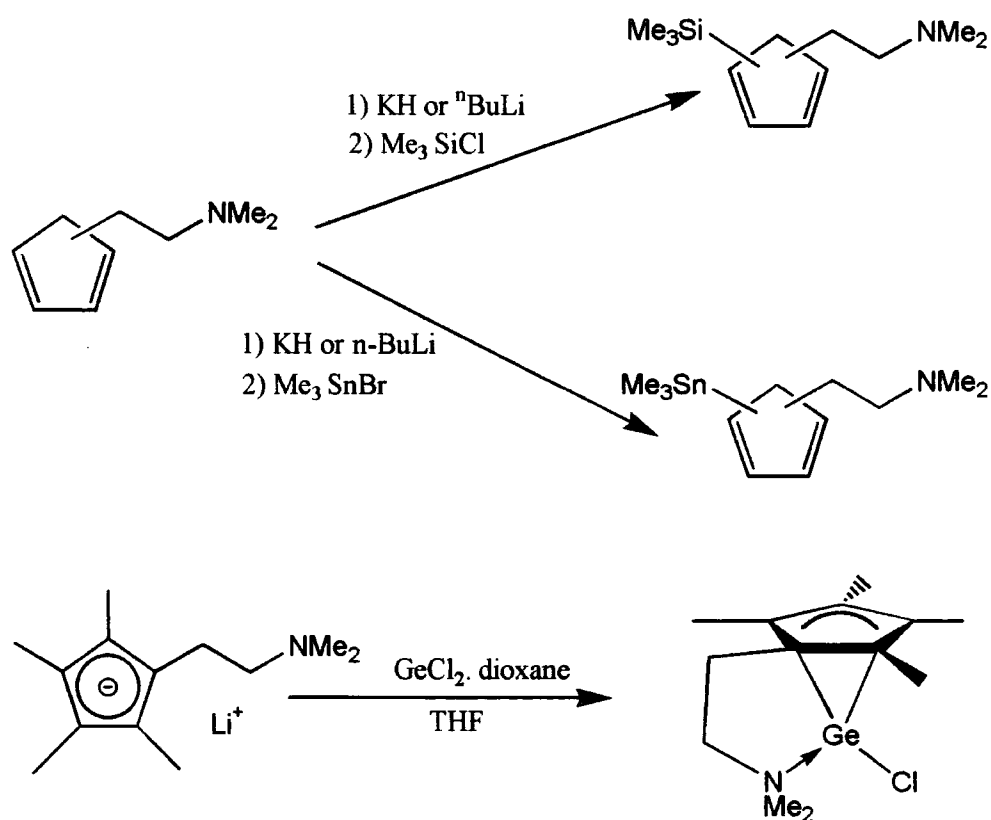

Figure 1.3.6: Group 14 complexes of a Lewis-base substituted cyclopentadienyl ligand

1.4: Early Transition Metal Chemistry

Since early transition metal cyclopentadienyl complexes dominate homogeneous Ziegler-Natta olefin polymerisation chemistry, it is not surprising that their complexes with donor-functionalised cyclopentadiene ligands have been investigated in more detail than those of any other group of metals, and this is particularly true for titanium and zirconium. This section aims to give a review of the chemistry of these ligands with metals in groups 4, 5 and 6, as well as the group 3 metal scandium. Complexes of various functionalised cyclopentadienes with yttrium and lanthanum will be discussed in section 1.6 along with complexes of lanthanide metals.

1.4.1: Scandium

Scandocene derivatives of the $C_5Me_4SiMe_2NR^2$ ligand (known as "Cp^{*}-sinner") have been synthesised for use in mechanistic studies of the Ziegler-Natta α -olefin polymerisation system. The dimeric scandium hydride complex $[(Cp^*SiMe_2N^tBu)Sc(PMe_3)]_2(\mu-H)_2$, shown in figure 1.4.1, cleanly catalysed the oligomerisation of propene, 1-butene and 1-pentene in the absence of a co-catalyst.³¹ This complex was converted into an alkyl-bridged complex (also shown in figure 1.4.1) which also catalysed the oligomerisation of these monomers.³²

Oligomerisation reactions using both catalyst precursors were sluggish and produced low molecular weight oligomers rather than polymers, but these scandium complexes are still of vital importance since they provide the first opportunity for study of Ziegler-Natta α -olefin polymerisation in the absence of MAO or another co-catalyst. Mechanistic studies are also more successfully performed with catalysts which proceed relatively slowly, allowing individual reaction steps to be observed.

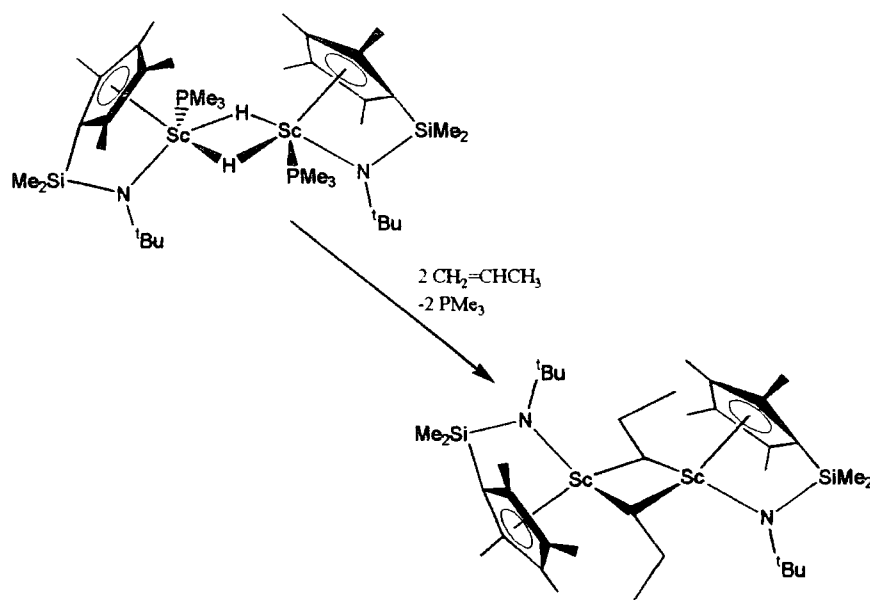

Figure 1.4.1: Scandium complexes of the Cp*SiMe₂N^tBu ligand

1.4.2: Group 4

Complexes of a great many functionalised cyclopentadienyl ligands with group 4 metals have been studied, with a view to preparing new catalytically active species, or stabilising catalytically active metal-ligand fragments to allow them to be studied. Since both metallocenes and half-sandwich complexes of group 4 metals are of great importance in olefin polymerisation, complexes of both these types have been made. Bis(cyclopentadienyl) complexes usually contain ligands which are co-ordinated to the metal through the cyclopentadiene ring only, leaving the donor group pendant. Half-sandwich complexes have been made where donor groups are either pendant or are co-ordinated intramolecularly to the metal centre.

The chemistry of the dimethylaminoethyl cyclopentadienyl ligand with titanium and zirconium has been investigated fairly comprehensively, and is summarised in figure 1.4.2.³³ The aim of the work was to prepare bent metallocene type complexes from which cationic

species might be generated, stabilised by a weak intramolecular nitrogen co-ordination but still active in catalysis. Reaction of alkali metal dimethylaminoethyl cyclopentadienides with TiCl_4 or ZrCl_4 yielded oligomeric and polymeric species, although an analogous diisopropylaminoethyl cyclopentadienyl ligand under similar conditions gave a monomeric bent metallocene dichloride, characterised by X-ray crystallography.³⁴ The oligomeric and polymeric metallocene dichloride analogues of the dimethylethylamino cyclopentadienyl ligand underwent metathesis reactions with alkyl lithium salts to give monomeric metallocene dialkyl species which could be protonated at the amine nitrogen, giving rise to a dicationic species and offering the potential for organometallic chemistry in highly polar solvents, including water. The trimethylsilyl derivative of the dimethylaminoethyl cyclopentadienyl ligand reacted with CpTiCl_3 to give a mixed metallocene species. It is interesting to note that reaction between the free ligand and $\text{Ti}(\text{NMe}_2)_4$ led to only one NMe_2 ligand being displaced from the metal centre, giving rise to a species in which the amine nitrogen is not co-ordinated to the metal centre. This is in contrast with primary amine substituted ligands (such as those studied by this group) in which the nitrogen also displaces an NMe_2 ligand, becoming intramolecularly co-ordinated as an amide.⁹

A complex has been prepared of the dimethylaminoethyl cyclopentadienyl ligand in which the ligand is co-ordinated to titanium through the cyclopentadienyl ring and intramolecularly through the amine nitrogen.¹¹ This complex, shown in figure 1.4.3, undergoes hydrolysis in the presence of moisture to give a dimeric, oxide bridged species with the amine groups protonated. The intramolecularly co-ordinated complex $(\text{C}_5\text{H}_4(\text{CH}_2)_2\text{NMe}_2)\text{TiCl}_3$, activated with MAO, was tested for catalytic activity for the polymerisation of styrene, ethylene and propylene. The system exhibited relatively low activity and lower stereoselectivity towards styrene polymerisation compared to

$(C_5H_5)TiCl_3/MAO$ or $(C_9H_7)TiCl_3/MAO$. In contrast, the system exhibited substantial activity towards the polymerisation of ethylene and propylene, for which $(C_5H_5)TiCl_3/MAO$ is virtually inactive. However, the propylene polymerisation was without stereoselectivity. It was thought that these effects on activity and stereoselectivity were due to the intramolecular co-ordination of the amino group.

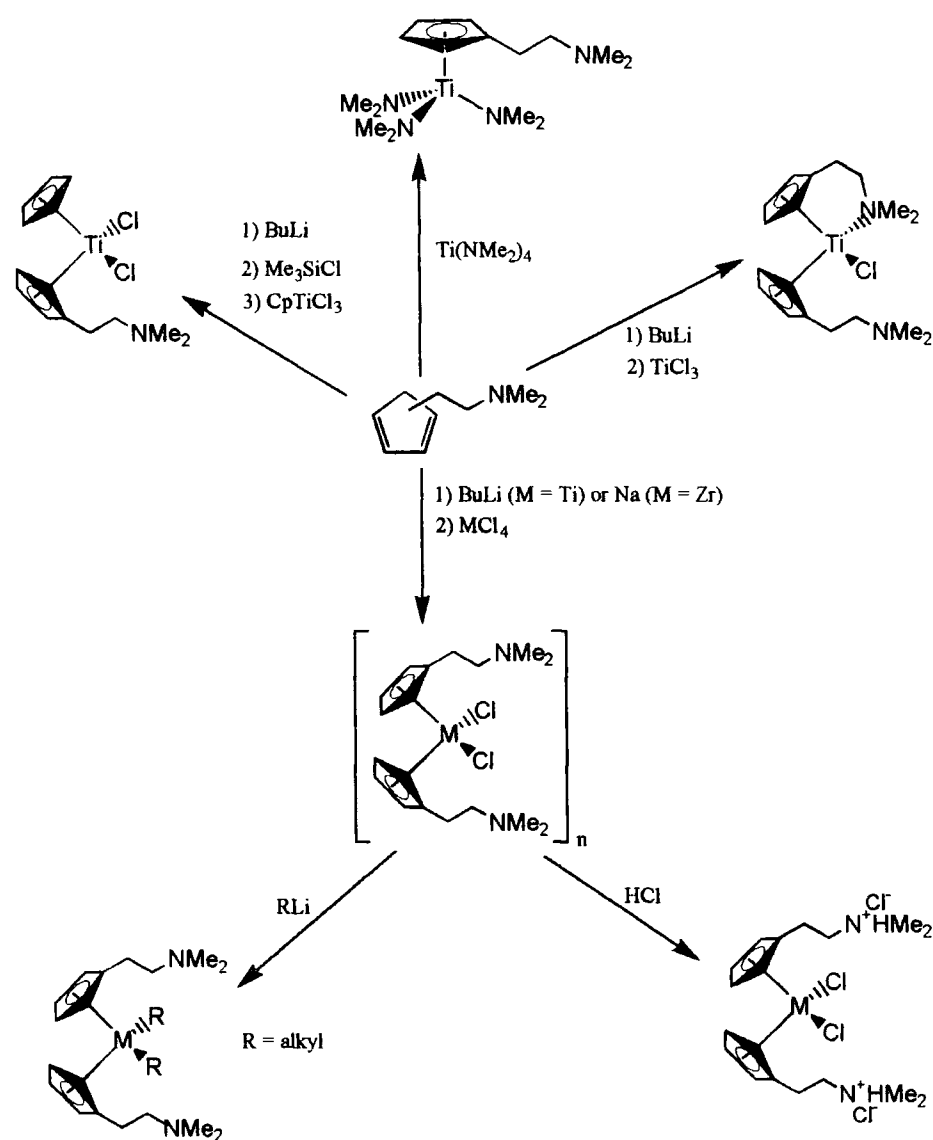

Figure 1.4.2: Chemistry of the dimethylaminoethyl cyclopentadienyl ligand with group 4 metals

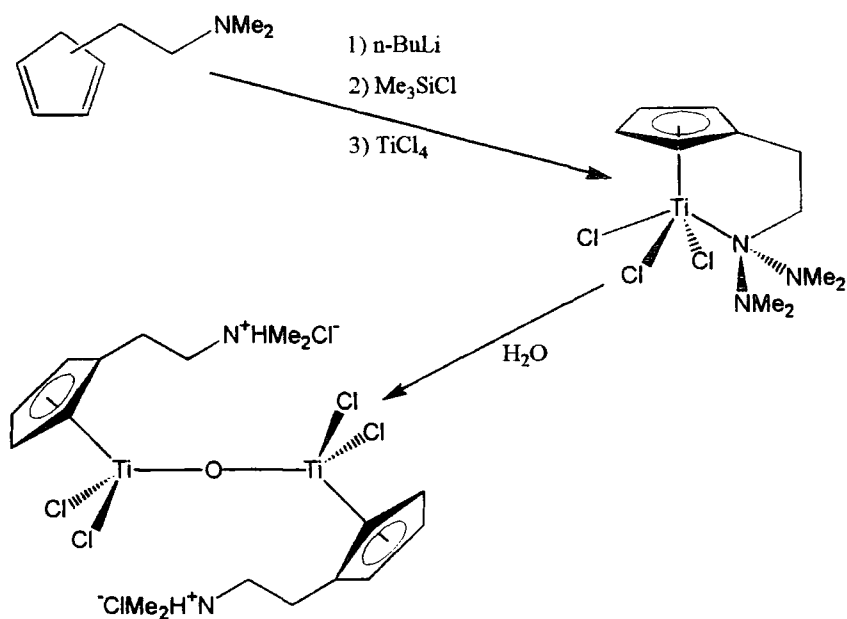

Figure 1.4.3: Half-sandwich titanium dimethylaminoethyl cyclopentadienyl complex with intramolecularly co-ordinated nitrogen

A related group of ligands has been synthesised where the dimethylamino group attached to the two carbon chain has been replaced by a cyclic amine group as shown in figure 1.4.4.³⁵

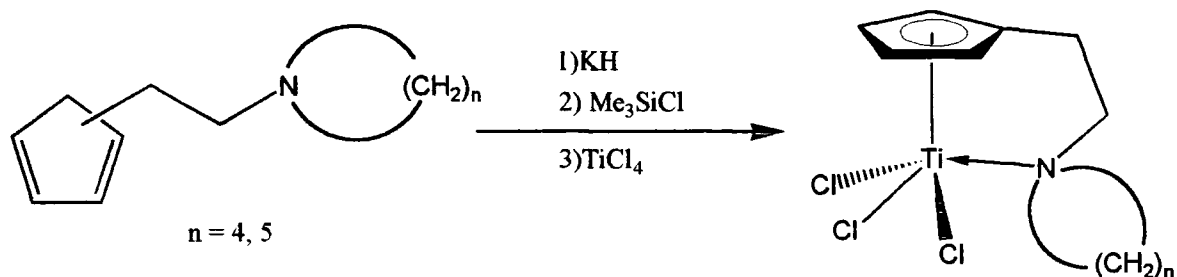

Figure 1.4.4: Cyclopentadienyl ligands bearing cyclic amine-substituents

Amine-functionalised ligands have also been prepared where an Me_2Si unit replaces the carbon chain as a spacer between the cyclopentadiene and the amine. This leads to

increased strain in the system when the amine group is co-ordinated intramolecularly, which would in turn be expected to lead to greater catalytic activity compared to species with a two or three carbon chain. The complex $(Cp^*SiMe_2NR)TiCl_2$, shown in figure 1.4.4, where $R = tBu$ or Ph , has been shown to be a highly active catalyst for the polymerisation of ethylene and for the random co-polymerisation of 1-octene/ethylene when activated with a co-catalyst such as MAO or $B(C_6F_5)_3$.³⁶ Similar complexes have been made with the ligand $(tBuC_5H_4SiNH^tBu)$, an example of which is also shown in figure 1.4.5.³⁷

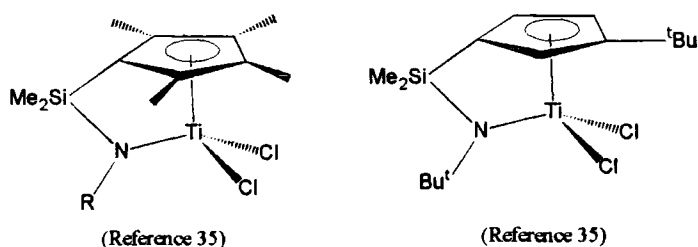

Figure 1.4.5: Amine-substituted cyclopentadienyl complexes with $SiMe_2$ spacer units

These silyl-spaced ligands have been further developed to produce tridentate ligands where a C_2H_4 chain bearing a further donor atom is attached to the amine nitrogen. Such ligands have been made based on both cyclopentadiene³⁸ and on tetramethylcyclopentadiene.³⁹ The third donor functionality is an ether or an amine, and complexes have been made in which the ligand is bidentate or tridentate as shown in figure 1.4.6.

Amine-functionalised indenyl ligands have been synthesised where the amine group is attached directly to the ring with no spacer units at all. This makes intramolecular co-ordination of the amine nitrogen impossible, but the presence of a strong Lewis-base directly attached to the ring leads to changes in the electronic properties of the ring which

have significant effects on the catalytic properties of titanocene and zirconocene complexes of these ligands. 3,4-diphenylcyclohex-2-enone has been used as a precursor to cyclic-amine substituted zirconocenes and to linked zirconocenes with amine substituted backbones,⁴⁰ and some examples are shown in figure 1.4.7. These complexes have been tested for olefin polymerisation activity in the presence of MAO co-catalyst. The N,N'-dimethylethylenediamine linked species C proved to have high activity, but activity for the unlinked species A and B was low (letters A, B and C refer to figure 1.4.7).

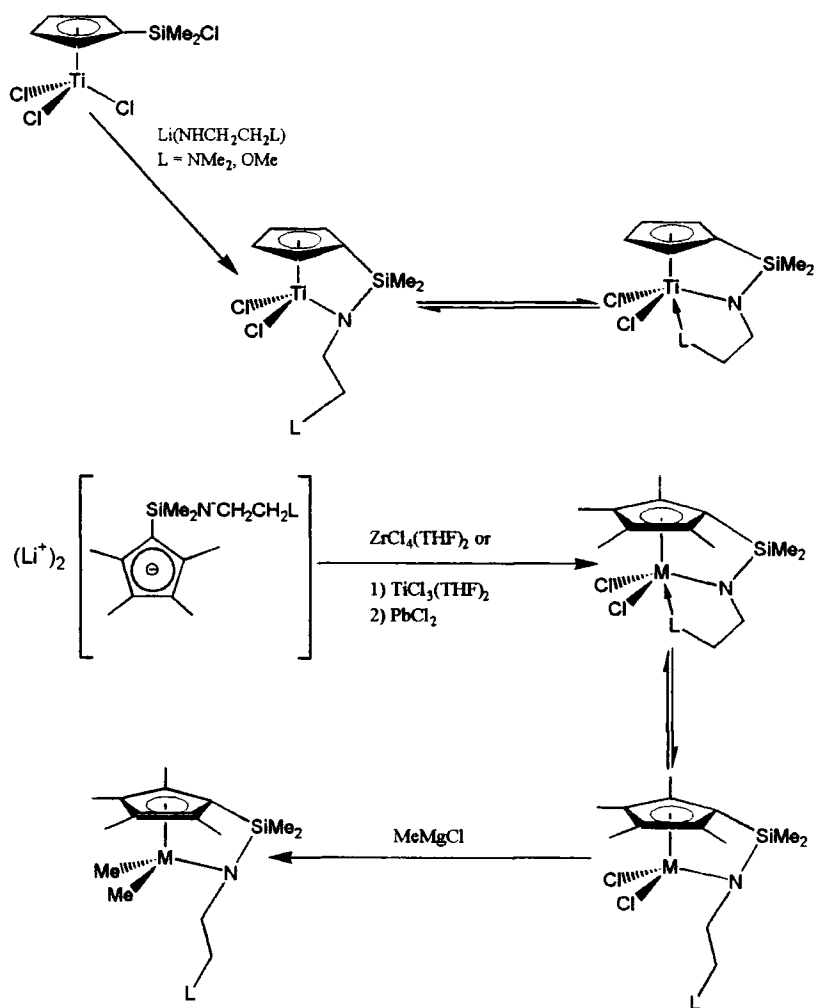

Figure 1.4.6: Tridentate functionalised cyclopentadienyl ligands

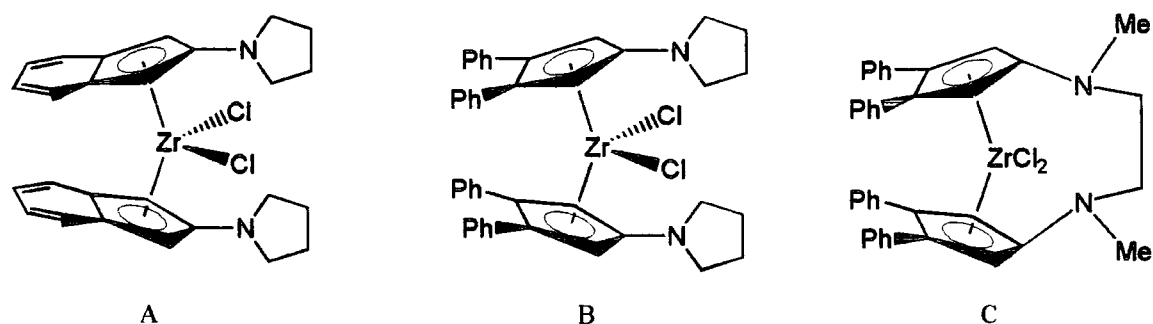

Figure 1.4.7: Amine-substituted zirconocenes

1-dimethylamino indene has also been used to prepare a variety of zirconocene-type complexes, as has a bis(1-dimethylamino indene) with a SiMe_2 linkage,⁴¹ and some examples are shown in figure 1.4.8. The linked zirconocene complex polymerises propene in the presence of MAO co-catalyst with a rate and activity comparable to that of the unsubstituted SiMe_2 linked bis(indenyl) complex $\{(\text{C}_9\text{H}_6)_2\text{SiMe}_2\}\text{ZrCl}_2$. However, it exhibits an induction period which is unusual and could be due to the Lewis-base inhibiting the formation of catalytically active species.

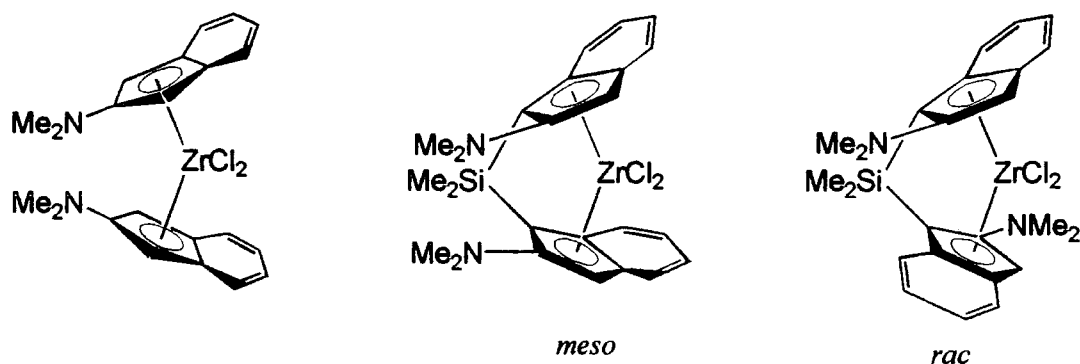

Figure 1.4.8: Zirconocene complexes of 1-dimethylamino indenyl ligands

The work described in this thesis is primarily concerned with amine-substituted cyclopentadienyl and indenyl ligands which differ from those discussed so far in two ways.

Firstly, we are concerned with increasing the length of the carbon chain to three CH₂ units, which has been shown for oxo-substituted ligands to give the ligand system more flexibility and reduce strain when co-ordinated intramolecularly.²⁹ Secondly we are studying ligands where the amine group is secondary rather than tertiary, enabling the nitrogen to function as an LX ligand when deprotonated. This work is a continuation of earlier studies on zirconium and hafnium complexes of methylaminopropyl cyclopentadiene, shown in figure 1.4.9.⁹

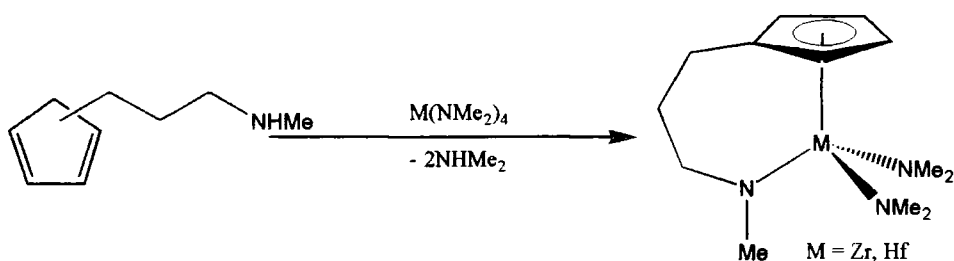

Figure 1.4.9: Group 4 complexes of a methylaminopropyl cyclopentadienyl ligand

Nitrogen is not the only donor atom which has been appended to a cyclopentadienyl ligand. Within the field of early transition metals, the next most studied donor atom is oxygen. Ligands have been synthesised with ether substituents attached to a cyclopentadienyl or C₅Me₄⁻ fragment. A complex has been made in which a 3-methoxypropyl tetramethylcyclopentadienyl ligand is co-ordinated to titanium through the cyclopentadienyl ring only. This was then converted into a bidentate alkoxide complex *via* intramolecular C-O activation as shown in figure 1.4.10.⁴² Various mixed metallocene complexes containing combinations of 2-methoxyethyl and 3-methoxypropyl cyclopentadienyl ligands have been made in order to study the effect of chain length upon chelation.⁴³ These are shown in figure 1.4.11.

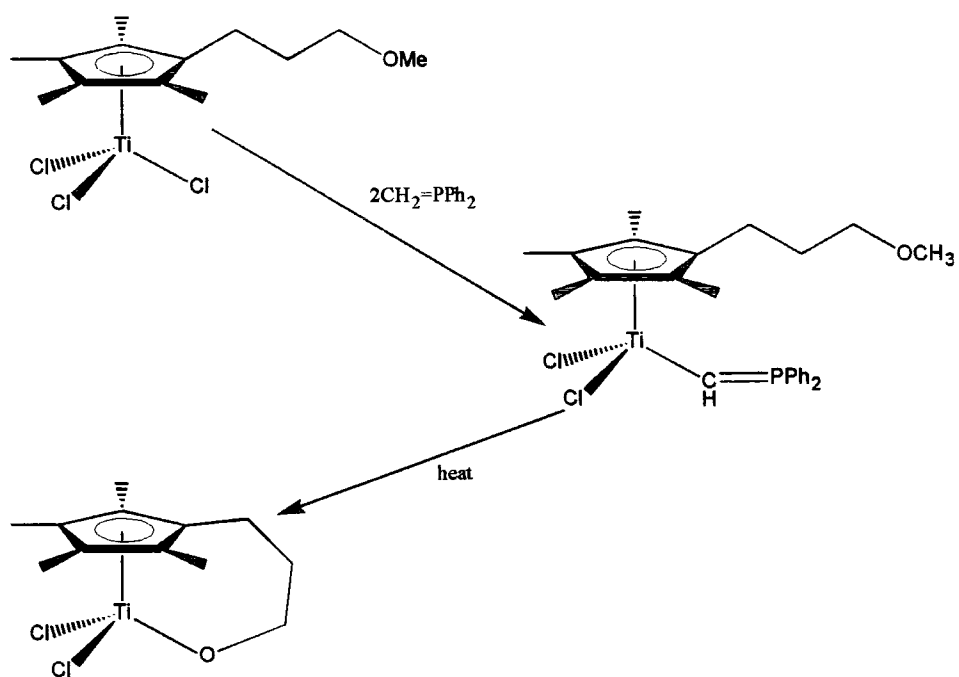

Figure 1.4.10: Bidentate alkoxy complex *via* intramolecular C-O activation

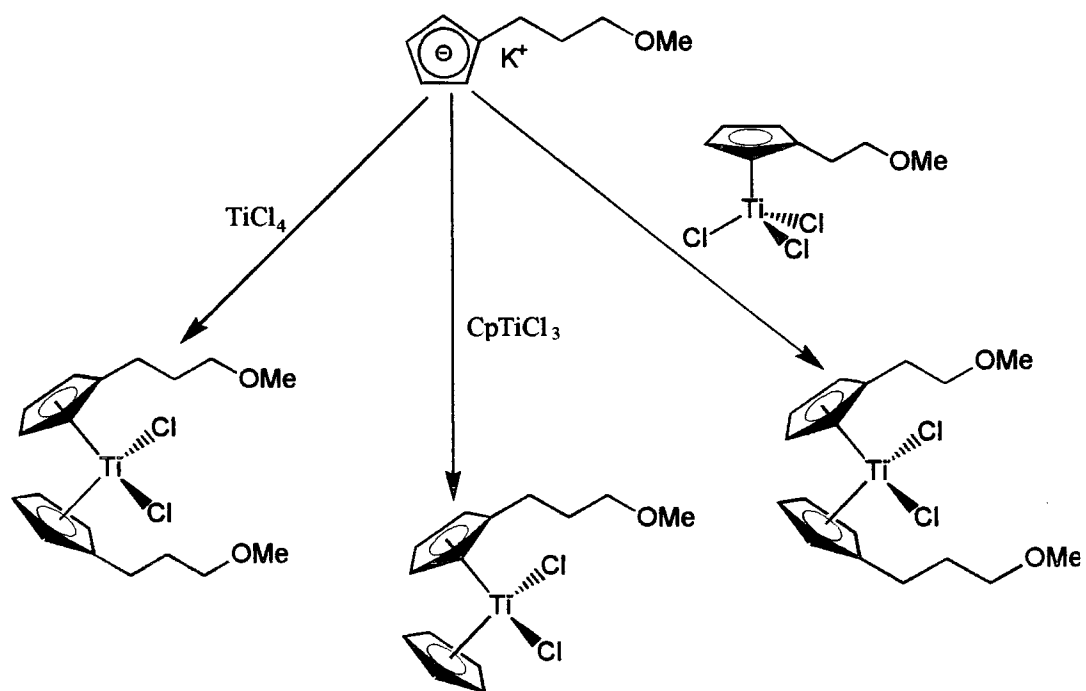

Figure 1.4.11: Complexes of 2-methoxyethyl and 3-methoxypropyl cyclopentadienyl ligands

In addition, a chiral chelating alkoxide ligand based on fluorene has been synthesised and converted into a zirconium complex as shown in figure 1.4.12.⁴⁴

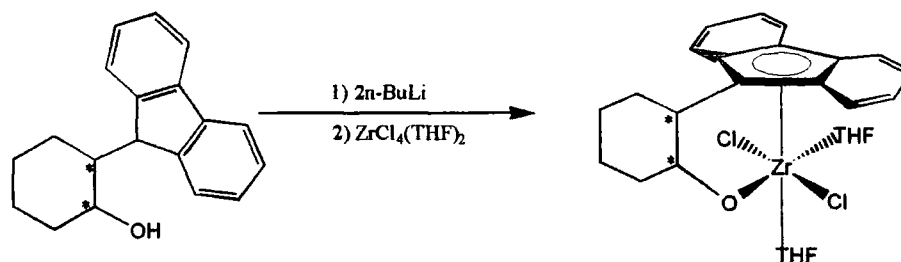

Figure 1.4.12: Chiral alkoxide-substituted fluorenyl ligand

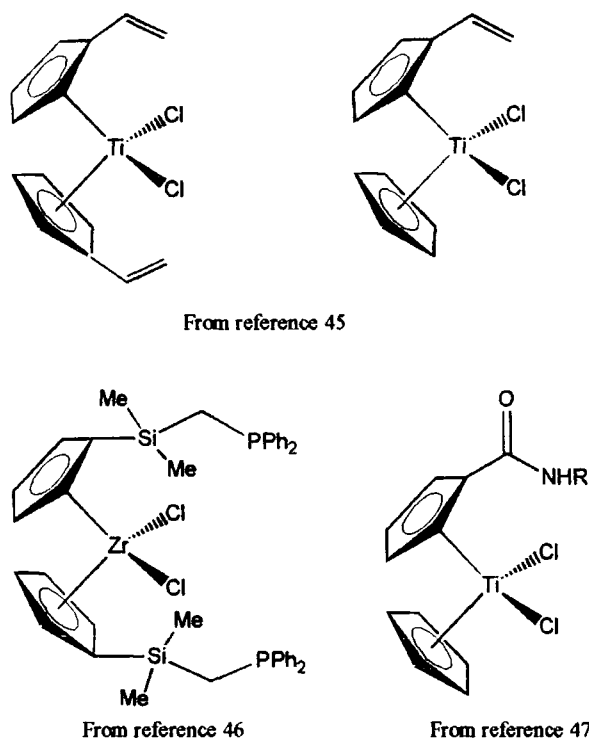

Figure 1.4.13: Other donor-functionalised group 4 complexes

Other donor functionalities have been used only rarely in the synthesis of group 4 complexes, being for the most part better suited for co-ordination to late transition metals. However, examples exist in the literature of complexes of group 4 metals with vinyl-⁴⁵

phosphine-⁴⁶ and carboxylic acid-⁴⁷ substituted cyclopentadienes. These are shown in figure 1.4.13.

1.4.3: Group 5 and 6 complexes

Group 5 and 6 metals have been less widely studied with respect to donor-functionalised cyclopentadiene ligands than have group 4 metals, mainly because potential catalytic applications are fewer. Cyclopentadienyl ligands with amine functionalities attached to the ring by a SiMe_2 spacer unit have been used to prepare complexes of Mo,⁴⁸ Nb and Ta⁴⁹ by aminolysis as shown in figure 1.4.14.

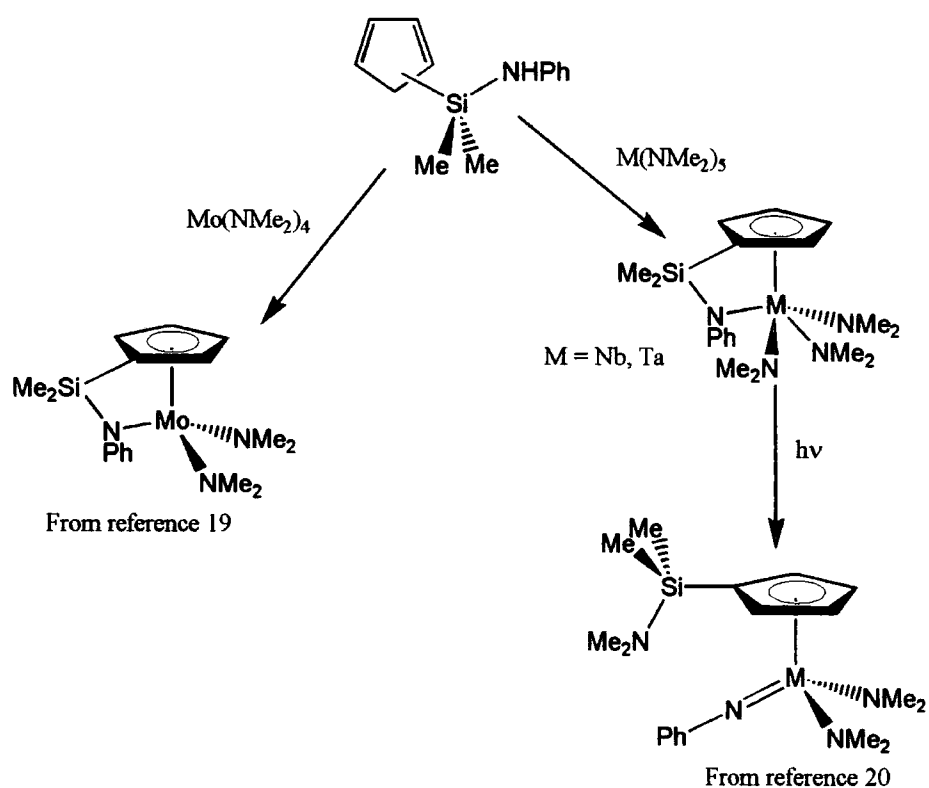

Figure 1.4.14: Group 5 and 6 complexes of an amine substituted cyclopentadienyl ligand with an SiMe_2 spacer unit

A primary amine-substituted cyclopentadiene has been used to prepare a linked cyclopentadienyl-imido complex of niobium, shown in figure 1.4.15.⁵⁰ The linked cyclopentadienyl-imido ligand is a 9 electron donor, yet occupies only a small part of the metal surface. This type of complex is expected to have very different properties to a bent metallocene since the metal has a greater positive charge yet is sterically less crowded.

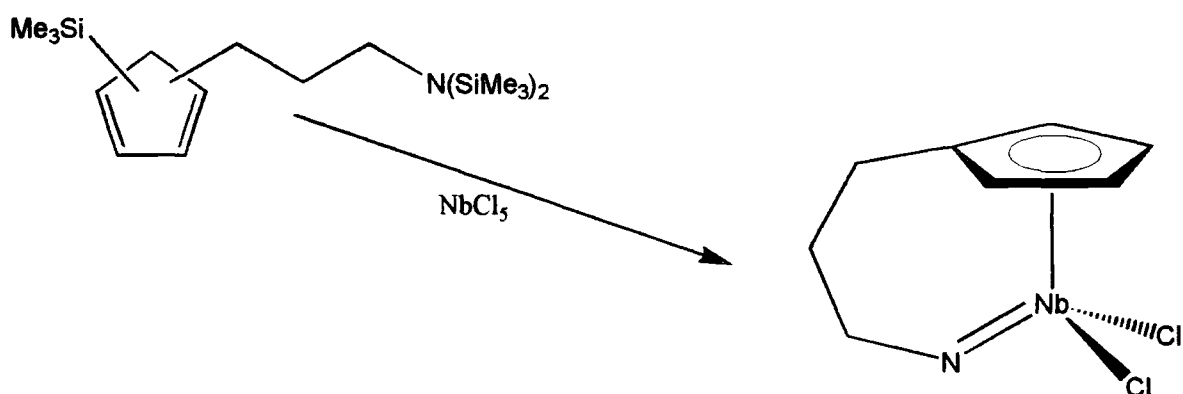

Figure 1.4.15: Linked cyclopentadienyl-imido complex of niobium

A dimethylaminoethyl cyclopentadienyl ligand with a methyl-substituent on the backbone has been used to prepare a molybdenum carbonyl complex in which the ligand is co-ordinated through the cyclopentadienyl ring only. Photolysis of this complex leads to loss of a carbonyl ligand and intramolecular co-ordination of the amine group.⁵¹ A molybdenum complex of the same ligand with a 1,3-hexadiene ligand has also been made. Again the ligand is co-ordinated through the ring only, and intramolecular co-ordination is achieved by removal of a carbonyl ligand using chemical means.⁵² This chemistry is summarised in figure 1.4.16.

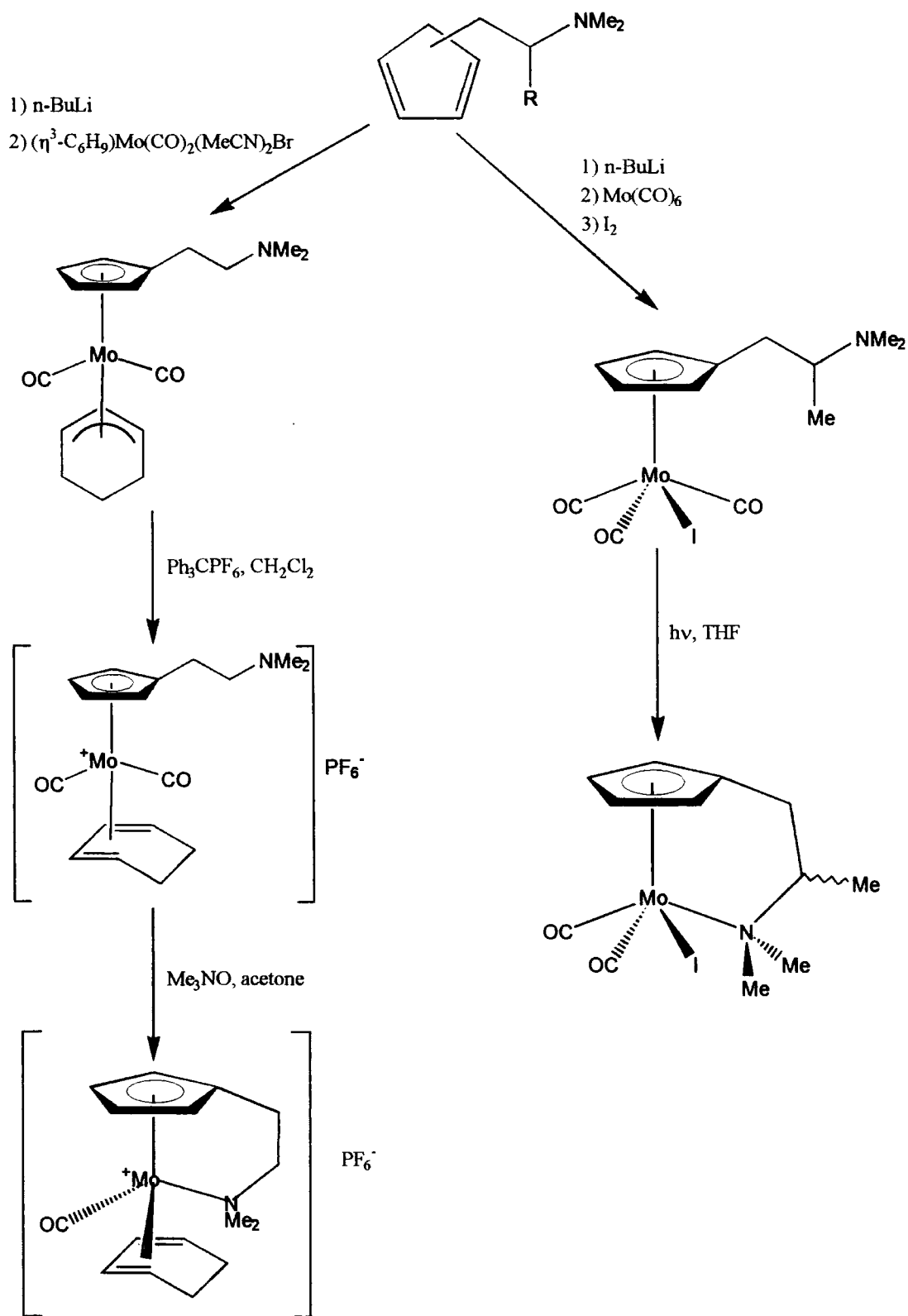

Figure 1.4.16: Molybdenum complexes of the dimethylaminoethyl cyclopentadienyl ligand (references 51 and 52)

1.5: Late Transition Metal Chemistry

1.5.1: Iron and manganese

Manganese has not been very widely studied with regard to donor-functionalised cyclopentadienyl ligands, since potential catalytic applications are few. Only one example has been found in the literature: a lithium dimethylaminoethyl cyclopentadienide with a methyl-substituted backbone reacted with $\text{Mn}(\text{CO})_3\text{Br}$ under vigorous conditions to give a cyclopentadienyl manganese tricarbonyl complex in which the substituted cyclopentadienyl ligand was co-ordinated through the ring only. Photolysis of the complex caused loss of one carbonyl ligand, enabling the amine nitrogen to co-ordinate intramolecularly to the metal centre, as shown in figure 1.5.1.⁵¹

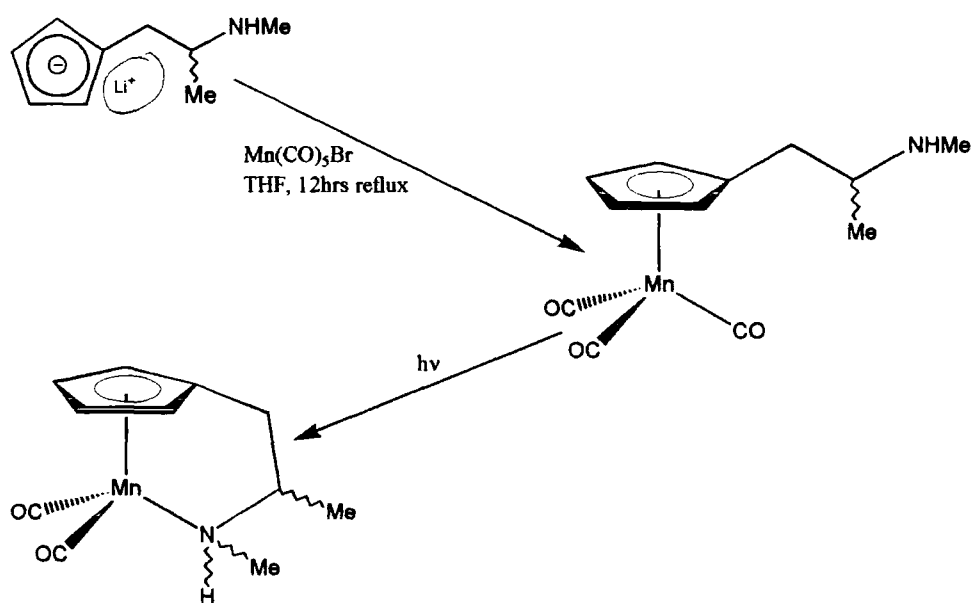

Figure 1.5.1: Mn complexes of an amine substituted cyclopentadienyl ligand

By contrast, there are many examples of iron complexes of this type of ligand, particularly of ferrocene-type complexes, since these are easy to make and are generally air- and moisture-stable. Ferrocene-type complexes have been made of cyclopentadienyl ligands with a wide variety of donor-functionalities including pyridyl,^{12, 19(a)} phosphine,^{46,53} vinyl⁵⁴ and carboxylic-acid amide.⁵⁵ Some examples are shown in figure 1.5.2.

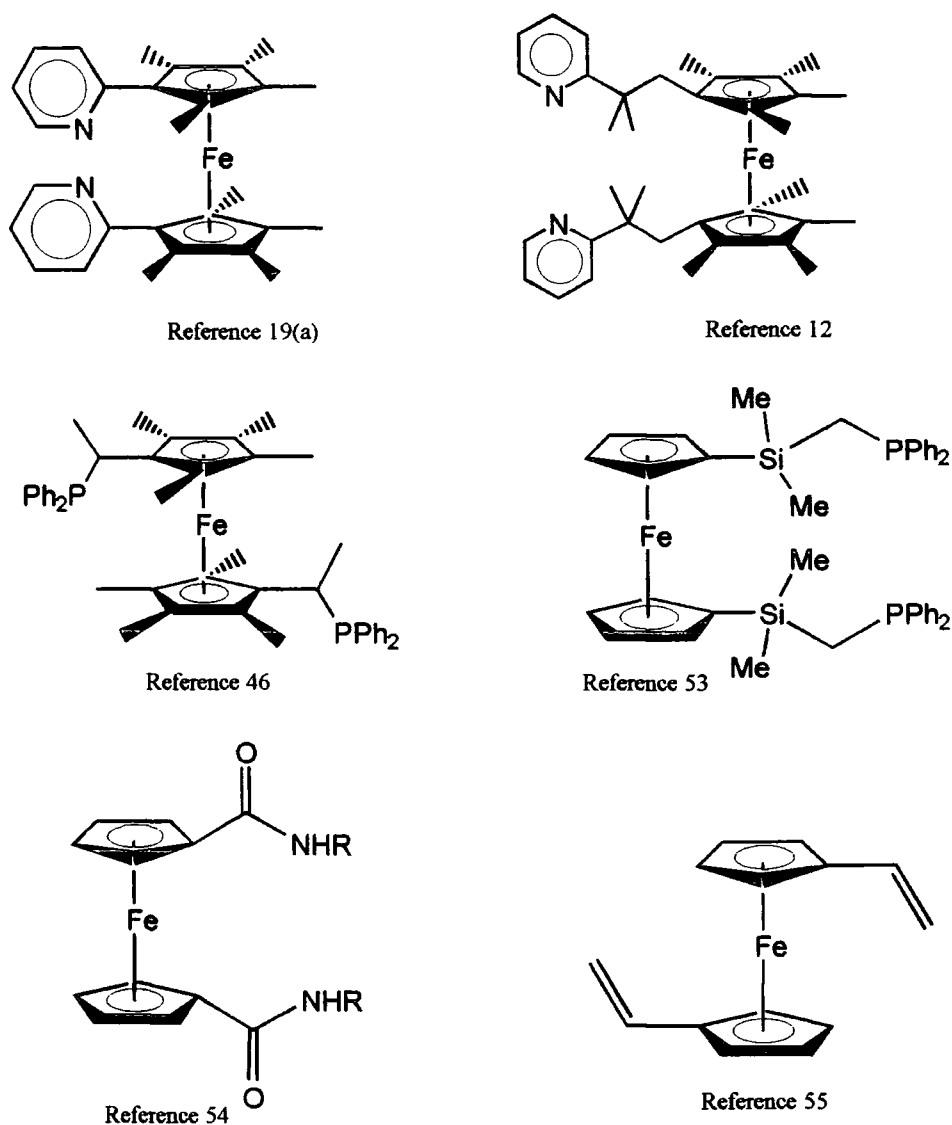

Figure 1.5.2: Some examples of ferrocene-type complexes with functionalised cyclopentadienyl ligands

These ferrocene-type complexes are very stable and have a pendant donor functionality which is available for co-ordination to a second metal, making them highly suitable building blocks for oligo- and heterometallic systems. This will be discussed more fully in chapter 3.

Complexes of iron where only one functionalised cyclopentadienyl ligand is present are much rarer, but a cyclopentadienyl ligand with a primary amine group attached to the ring by an SiMe_2 spacer unit has been used to prepare an iron (II) carbonyl complex where the ligand is co-ordinated through the ring and intramolecularly through the amine nitrogen, as shown in figure 1.5.3.³⁷

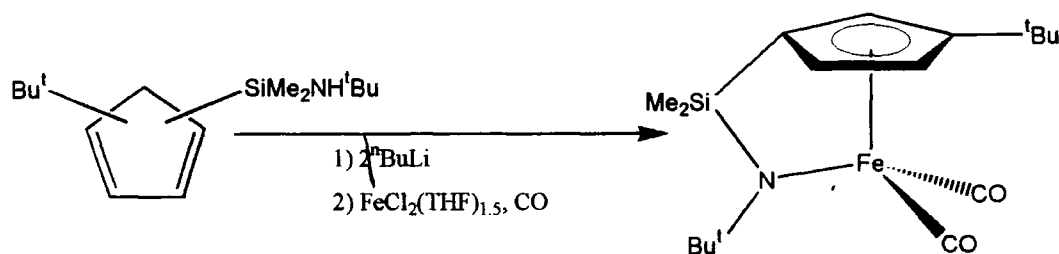

Figure 1.5.3: Iron (II) complex with an intramolecularly co-ordinated functionalised cyclopentadienyl ligand

1.5.2: Group 9

Cyclopentadienyl complexes of Co, Rh and Ir have been used in a number of important catalytic and stoichiometric reactions which rely on the formation of coordinatively and electronically unsaturated species as reactive intermediates.⁵⁶ Functionalised cyclopentadienes should be ideal ligands for the stabilisation of such species, especially where the substituent is a hard donor (such as nitrogen) that would co-ordinate

only loosely to late transition metals, allowing it to be displaced by softer donors such as alkenes.

The dimethylaminoethyl cyclopentadienyl and tetramethylcyclopentadienyl ligands have been widely studied with regard to their chemistry with Co,⁵⁷ and with Rh and Ir.¹⁷ Complexes of the metals in the +1 oxidation state were prepared by classical routes as shown in figure 1.5.4.

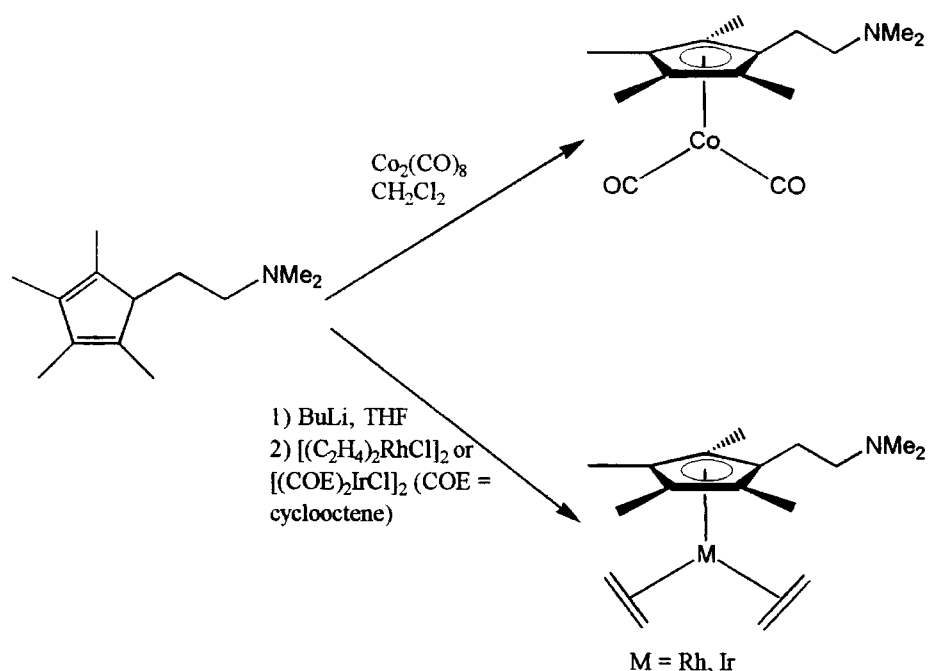

Figure 1.5.4: Preparation of Co, Rh and Ir complexes of an amine-substituted cyclopentadienyl ligand

No intramolecular co-ordination was observed, and photolysis did not lead to intramolecular co-ordination. However, oxidation of the metal to +3 (for example with iodine) gave complexes in which the ligand was co-ordinated intramolecularly. The metal-nitrogen bond was labile and could be displaced irreversibly by more strongly donating

ligands, such as C_2H_4 . With less strong donors such as CO it was possible to design systems in which co-ordination of the amine group was truly reversible, as shown in figure 1.5.5. It was concluded from this work that the co-ordination behaviour of the amino group depended on the formal oxidation state of the metal. No intramolecular co-ordination was observed for metals in the +1 oxidation state, while the co-ordination mode of the ligand to metals in the +3 oxidation state depended on the nature of the metal and the other ligands present.⁵⁸

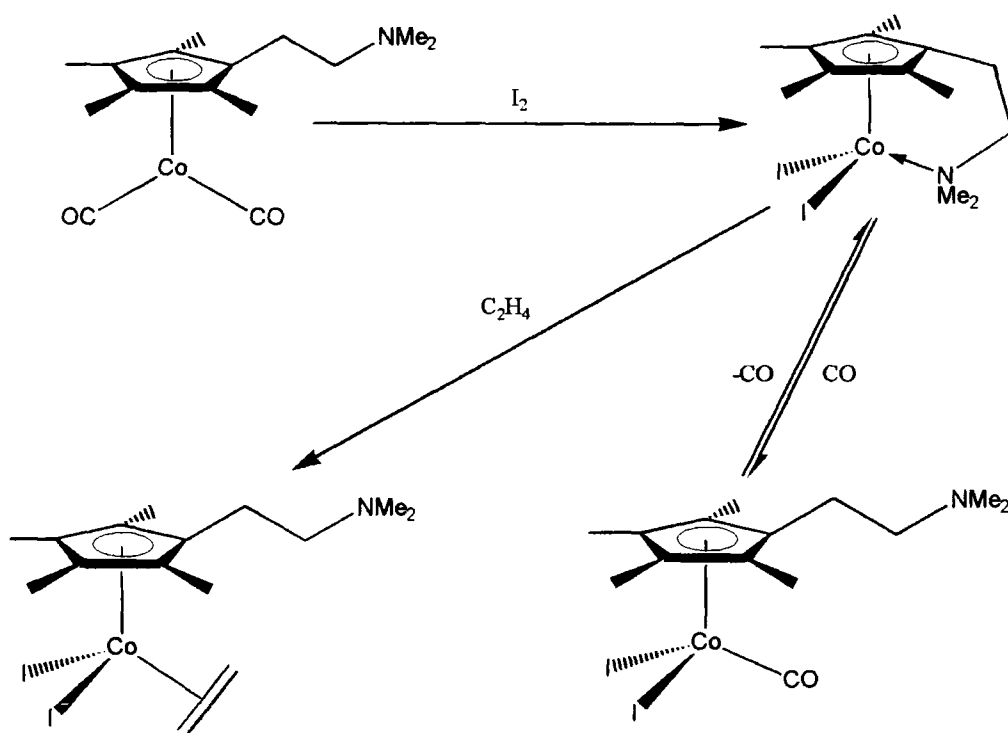

Figure 1.5.5: Co-ordination of the amino group in Co(III) complexes of an amine-substituted cyclopentadienyl ligand

A wide variety of ring substituted η^5 -cyclopentadienyl complexes of iridium have been synthesised as potential C-H activation intermediates.⁵⁹ The substituents used include $(\text{CH}_2)_2\text{NMe}_2$ and $(\text{CH}_2)_2\text{OMe}$.

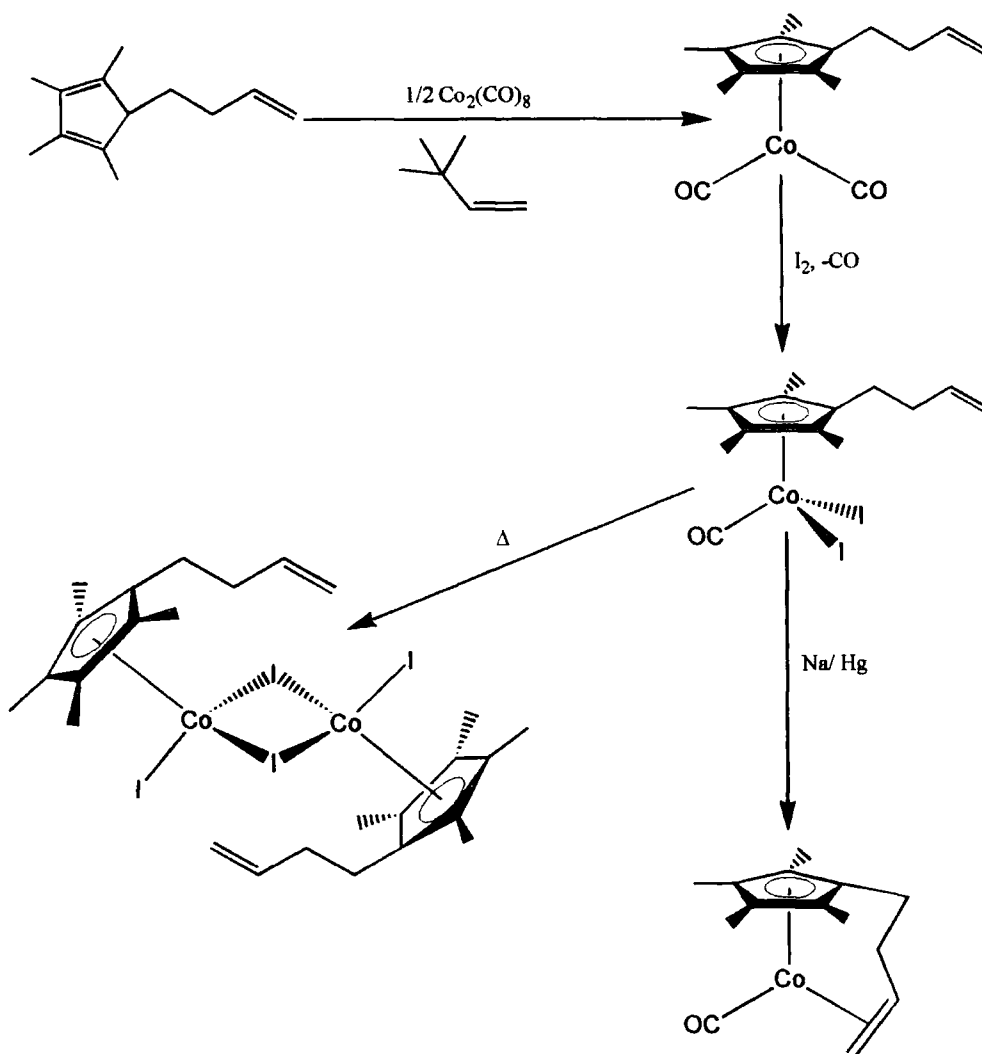

Figure 1.5.6: Cobalt complexes of a but-3-enyl cyclopentadiene ligand

Cobalt complexes of a tetramethylcyclopentadienyl ligand with a but-3-enyl substituent have been studied in great detail. A complex in which the ligand is co-ordinated to a Co(I) centre through the ring only has been synthesised by a classical route,⁶⁰ and can

be converted into a chloride-bridged dimer and thence into an intramolecularly co-ordinated species.⁶¹ The Co(I) complex can also be oxidised by iodine giving a monomeric species with the ligand pendant, which can either be converted to an iodide-bridged dimer or reduced to a Co(I) species in which the ligand is co-ordinated intramolecularly, as shown in figure 1.5.6. Cp*Co derivatives are known to catalyse the trimerisation of alkynes to give benzene derivatives, and the intramolecularly co-ordinated Co(I) tetramethylcyclopentadienyl but-3-enyl complex has also been investigated with regard to this reaction.⁶² It was found, however, that reaction of this complex with alkynes did not give benzene derivatives, but gave various metal complexes as shown in figure 1.5.7.

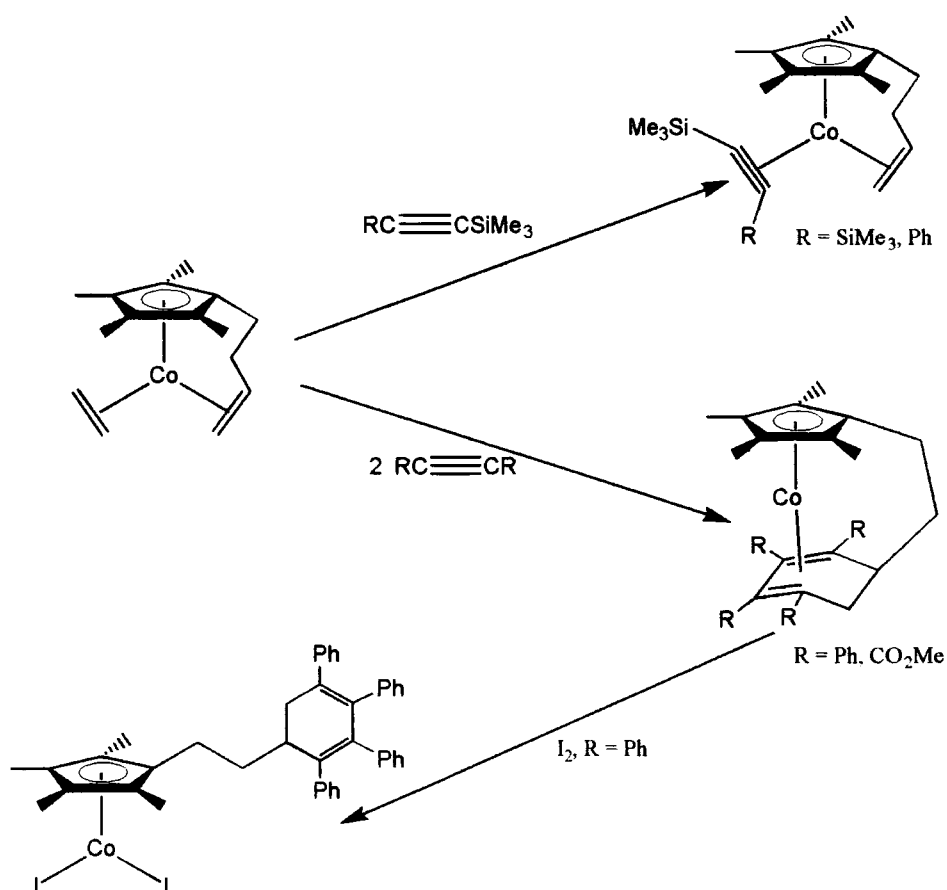

Figure 1.5.7: Attempted catalytic trimerisation of alkynes using a cobalt complex of an alkene-substituted cyclopentadienyl ligand

Phosphine-substituted cyclopentadienyl ligands have also been synthesised for coordination to late transition metals. Directly linked systems such as $C_5H_4PPh_2$,⁶³ or systems with short linkages such as $C_5H_4CH(CH_3)PPh_2$ ⁵³ (the ferrocene-type complex of which is shown in figure 1.5.1) tend to act preferentially as bridging ligands rather than chelating ligands, and will be discussed in chapter 3. A ligand has been synthesised in which the diphenylphosphino group is attached to the cyclopentadienyl ring by a two methylene unit chain, and this was found to act as a chelating ligand to rhodium and iridium in both the +1 and +3 oxidation states as shown in figure 1.5.8.⁶⁴

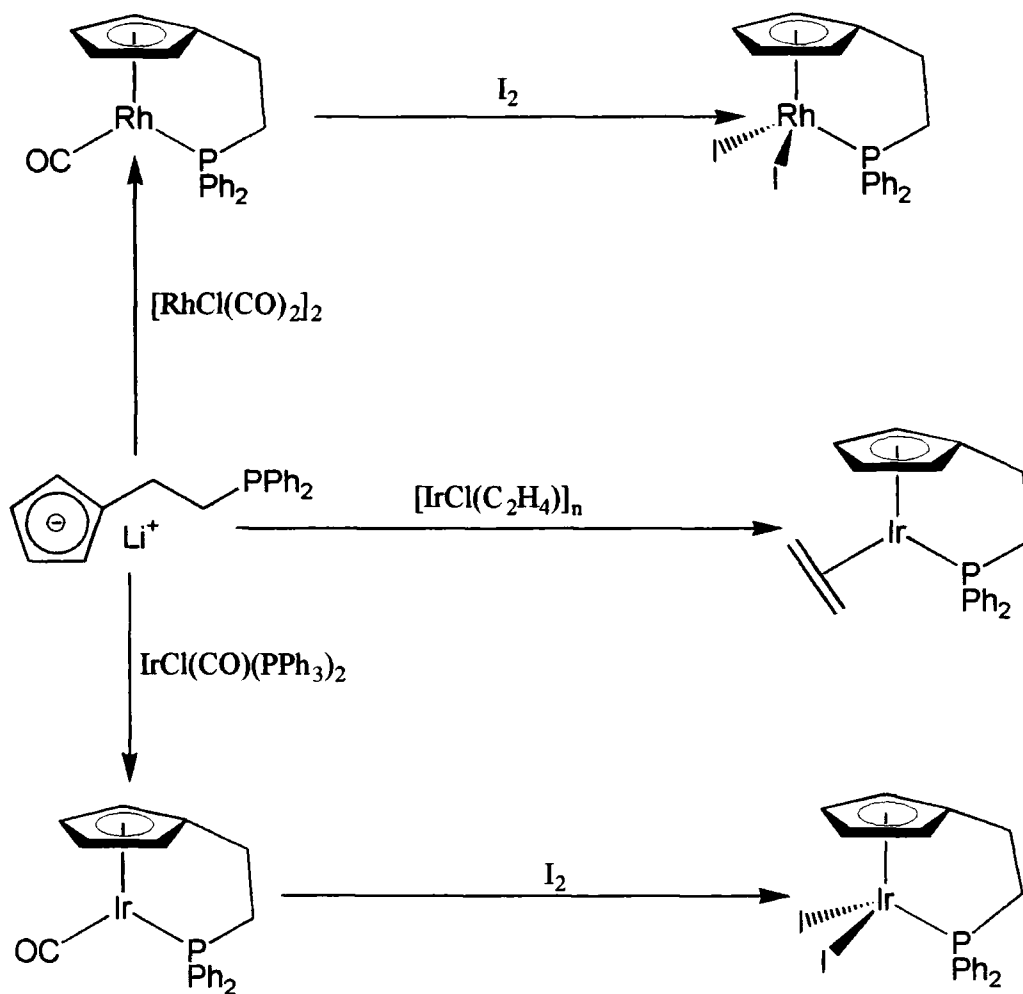

Figure 1.5.8: Rhodium and iridium complexes of the $C_5H_4(CH_2)_2PPh_2$ ligand

1.5.3: Group 10

Group 10 complexes of substituted cyclopentadienes have not been widely studied, with the exception of the $C_5H_4(CH_2)_2NMe_2$ ligand and its tetramethylcyclopentadienyl analogue, which have been comprehensively investigated for all three metals Ni, Pd and Pt as summarised in figure 1.5.9.^{58, 65} As with group 9, the workers were concerned as to whether or not the amino group would co-ordinate and hence whether it would be possible to stabilise catalytically active metal-ligand fragments for study. It was found that the amino group could not compete with CO, phosphine or π -allyl ligands, and intramolecular co-ordination of the amino group was not achieved for any of the metals in either the +1 or the +2 oxidation state.

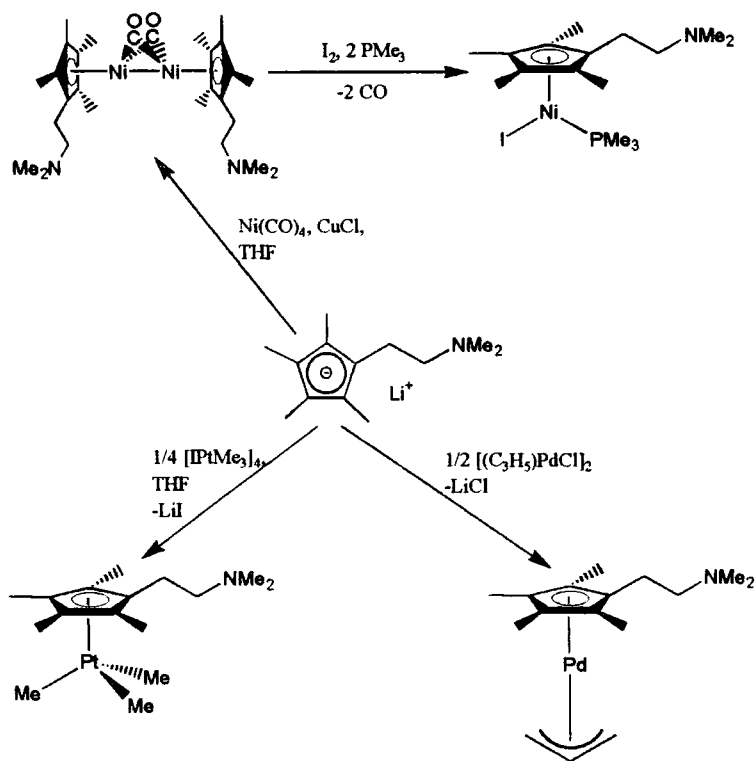

Figure 1.5.9: Group 10 complexes of the dimethylaminoethyl tetramethylcyclopentadienyl ligand

1.6: Lanthanides (Including Y and La)

The chemistry of functionalised cyclopentadienyl complexes of lanthanides is dominated by the 2-methoxyethyl cyclopentadienyl ligand. This can chelate to lanthanide metals, co-ordinating through both the cyclopentadienyl ring and the ether oxygen. Hence this ligand stabilises organolanthanide complexes and has been used to prepare a wide range of unusual complexes. For example, the ligand has been used to prepare monomeric, solvent free bis-cyclopentadienyl tetrafluoroborate⁶⁶ and iodide^{67, 68} complexes of lanthanides, shown in figure 1.6.1, which are fairly rare.

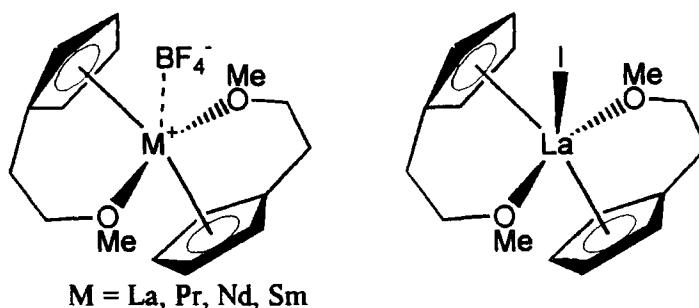

Figure 1.6.1: Iodide and tetrafluoroborate complexes of lanthanides

Bis(cyclopentadienyl) chloride complexes analogous to the iodide complex shown in figure 1.6.1 have been synthesised for the whole lanthanide series (except promethium) in order to investigate the effect of the lanthanide radius on co-ordination.⁶⁹ From this work it was discovered that ether oxygen always co-ordinates intramolecularly to the metal centre, regardless of the lanthanide radius. X-ray crystallography was used to determine the structures of the La, Dy and Yb complexes, and showed that the lanthanum complex (which has the largest radius cation) forms a chloride-bridged dimer (in contrast with the iodide shown in figure 1.6.1 which is a monomer), while the Dy and Yb complexes form as

monomers. This ligand has also been used to synthesise tris(cyclopentadienyl) complexes, as shown in figure 1.6.2.^{2(a)}

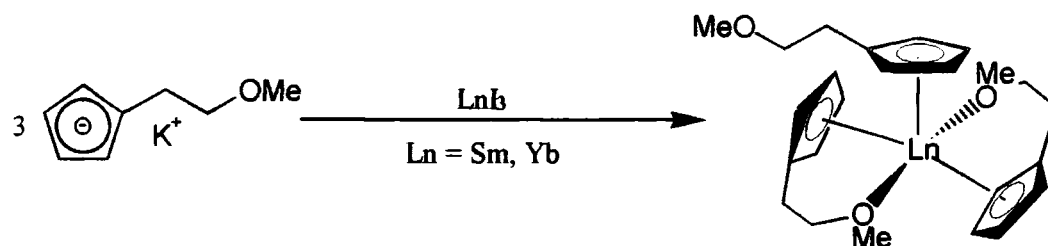

Figure 1.6.2: Tris(cyclopentadienyl) complexes of lanthanides

Pyridyl-functionalised cyclopentadienes have been used to make homoleptic lanthanocene (II) complexes, as shown in figure 1.6.3, which cannot generally be made from unsubstituted cyclopentadienyl or pentamethylcyclopentadienyl ligands due to the large radii of the lanthanides.^{20(a)} The permethylated N-dimethylethylamino cyclopentadiene has been used to make a homoleptic samariocene complex analogous to the calcium complex shown in figure 1.3.4.⁷⁰

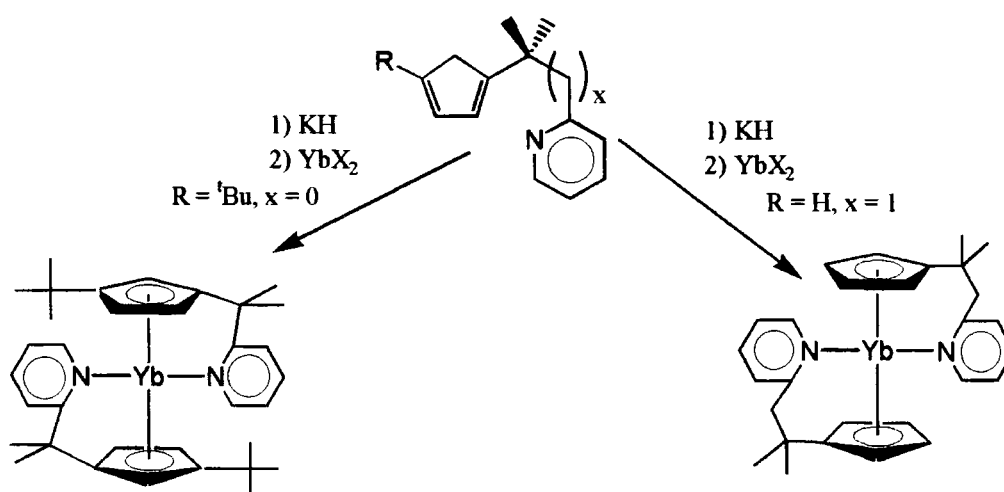

Figure 1.6.3: Homoleptic ytterbocene (II) complexes

1.7: Conclusions

It can be seen from this literature survey that the chemistry of Lewis-base functionalised cyclopentadienyl ligands is both rich and varied. Such ligands have been used to synthesise complexes of a huge range of different metals, with examples in the literature of complexes with s-, p-, d- and f-block metals. Many of these complexes have important implications for the study of catalytic processes. This thesis concentrates on the chemistry of tertiarybutylaminopropyl cyclopentadiene, in particular its synthesis and its compounds with various metals, particularly titanium. Lewis-base substituted indenyl ligands are rarer in the literature, but are expected to have an equally rich and varied organometallic chemistry. This thesis also contains reports of some preliminary work on the synthesis of tertiarybutylaminopropyl-2-indene and its complexes with iron and zirconium.

1.7: References for Chapter 1

- 1) G. Wilkinson, F. G. A. Stone and E. W. Abel (eds), "*Comprehensive Organometallic Chemistry*", 9 Vols., Pergamon Press (Oxford), 1982, 9569 pp; G. Wilkinson, F. G. A. Stone and E. W. Abel (eds), "*Comprehensive Organometallic Chemistry II*", Pergamon Press (Oxford), 1995.
- 2) Recent reviews include: (a) P. Jutzi, *Adv. Organomet. Chem.*, 1986, **26**, 217; (b) C. Janiak and H. Schumann, *Adv. Organomet. Chem.*, 1991, **33**, 291; (c) J. Okuda, *Top. Curr. Chem.*, 1991, **160**, 97; (d) N. J. Colville, K. E. du Plooy and W. Pickl, *Coord. Chem. Rev.*, 1992, **116**, 1; (e) J. Okuda, *Nachr. Chem. Tech. Lab.*, 1993, **41**, 8.
- 3) (a) H. Sinn, W. Kaminsky, H. J. Vollmer and R. Woldt, *Angew. Chem.*, 1980, **92**, 396; (b) W. Kaminsky, K. Kulper, H. Brintzinger and F. R. W. P. Wild, *Angew. Chem., Int. Ed. Engl.*, 1985, **24**, 507; (c) J. A. Ewen in "*Catalytic Polymerisation of Olefins*", Eds T. Keii and K. Soga, Elsevier (New York), 1986, p217; (d) K. Hormann and H. H. Brintzinger, *New. J. Chem.*, 1992, **16**, 1; (e) T. J. Marks, *Acc. Chem. Res.*, 1992, **25**, 57; (f) R. F. Jordan, *Adv. Organomet. Chem.*, 1991, **32**, 325; (g) G. H. Llinas, R. D. Day, M. D. Rausch and J. C. W. Chien, *Organometallics*, 1993, **12**, 1283.
- 4) (a) N. Ishihara, M. Kuramoto and M. Voi, *Macromolecules*, 1988, **21**, 3356; (b) A. Zambelli, L. Oliva and C. Pellecchia, *Macromolecules*, 1989, **22**, 2129; (c) T. E. Ready, R. O. Day, J. C. W. Chien and M. D. Rausch, *Macromolecules*, 1993, **26**, 5822
- 5) R. L. Halterman, *Chem. Rev.*, 1992, **92**, 965.
- 6) G. M. Diamond, S. Rodewald and R. F. Jordan, *Organometallics*, 1995, **14**, 5.
- 7) Z. Chen and R. L. Halterman, *Organometallics*, 1994, **13**, 3932 and references therein.
- 8) R. G. Pearson, *J. Am. Chem. Soc.*, 1963, **85**, 3533.
- 9) A. K. Hughes, A. Meetsma and J. H. Teuben, *Organometallics*, 1993, **12**, 1936.

- 10) E. A. Bijpost, R. Ducheteau and J. H. Teuben, *J. Molec. Catal. A*, 1995, **95**, 121.
- 11) J. C. Flores, J. C. W. Chien and M. D. Rausch, *Organometallics*, 1994, **13**, 4140.
- 12) U. Siemeling, B. Neumann and H.-G. Stammler, *Z. Naturforsch B*, 1994, **49**, 683.
- 13) For recent reviews see: (a) M. Barton and J. D. Atwood, *J. Coord. Chem.*, 1991, **24**, 43; (b) P. Kalck and F. Monteuil, *Adv. Organomet. Chem.*, 1992, **34**, 219; (c) W. A. Hermann and C. W. Kohlpaintner, *Angew. Chem.*, 1993, **105**, 1558, *Int. Ed. Engl.*, 1993, **32**, 1524.
- 14) P. Jutzi, J. Dalhaus, B. Neumann and H.-G. Stammler, *Organometallics*, 1996, **15**, 747.
- 15) P. Jutzi, J. Dalhaus and M. Bangel, *J. Organomet. Chem.*, 1994, **474**, 55.
- 16) P. Jutzi, H. Schmidt, B. Neumann and H.-G. Stammler, *J. Organomet. Chem.*, 1995, **499**, 7.
- 17) P. Jutzi, M. O. Kristen, B. Neumann and H.-G. Stammler, *Organometallics*, 1994, **13**, 3854.
- 18) P. Jutzi, T. Redeker, B. Neumann and H.-G. Stammler, *J. Organomet. Chem.*, 1995, **498**, 127.
- 19) (a) U. Siemeling, O. Vorfeld, B. Neumann and H.-G. Stammler, *Chem. Ber.*, 1995, **128**, 481; (b) U. Siemeling, B. Neumann and H.-G. Stammler, *Z. Naturforsch B*, 1994, **49**, 683; (c) J. Okuda and K. H. Zimmerman, *J. Organomet. Chem.*, 1988, **344**, C1.
- 20) (a) J. R. van den Hende, P. B. Hitchcock, M. F. Lappert and T. A. Nile, *J. Organomet. Chem.*, 1994, **472**, 79; (b) D. Deng, C. Qian, F. Song, Z. Wang, G. Wu, P. Zheng, S. Jin and Y. Lin, *J. Organomet. Chem.*, 1993, **458**, 83.
- 21) Y. Qian and G. Li, *Polyhedron*, 1993, **12**, 967.
- 22) P. Jutzi and U. Siemeling, *J. Organomet. Chem.*, 1995, **500**, 175.
- 23) P. Jutzi, J. Dalhaus and M. O. Kristen, *J. Organomet. Chem.*, 1993, **450**, C1.
- 24) W. S. Rees, U. W. Lay and K. A. Dippel, *J. Organomet. Chem.*, 1994, **483**, 27.
- 25) P. Jutzi, J. Dalhaus and M. O. Kristen, *J. Organomet. Chem.*, 1993, **445**, 79.
- 26) P. Jutzi and M. Bangel, *J. Organomet. Chem.*, 1994, **480**, C18.

- 27) P. Jutzi, J. Dalhaus, B. Neumann and H.-G. Stammer, *Organometallics*, 1996, **15**, 747.
- 28) P. Jutzi, J. Dalhaus and M. Bangel, *J. Organomet. Chem.*, 1994, **474**, 55.
- 29) G. Trouvé, D. A. Laske, A. Meetsma and J. H. Teuben, *J. Organomet. Chem.*, 1996, **511**, 255; for other examples see section 1.4.
- 30) P. Jutzi, H. Schmidt, B. Neumann and H.-G. Stammer, *J. Organomet. Chem.*, 1995, **499**, 7.
- 31) P. J. Shapiro, E. Bunel, W. P. Scafer and J. E. Bercaw, *Organometallics*, 1990, **9**, 867.
- 32) P. J. Shapiro, W. D. Cotter, W. P. Schaefer, J. A. Labinger and J. E. Bercaw, *J. Am. Chem. Soc.*, 1994, **116**, 4623.
- 33) P. Jutzi and J. Kleimeier, *J. Organomet. Chem.*, 1995, **489**, 287; P. Jutzi and U. Siemeling, *J. Organomet. Chem.*, 1995, **500**, 175.
- 34) P. Jutzi, T. Redeker, B. Neumann and H.-G. Stammer, *Organometallics*, 1996, **15**, 4153.
- 35) W. A. Hermann, M. J. A. Morawietz, T. Priermeier and K. Mashima, *J. Organomet. Chem.*, 1995, **486**, 291.
- 36) D. D. Devore, F. J. Timmers, D. L. Hasha, R. K. Rosen, T. J. Marks, P. A. Deck and C. L. Stern, *Organometallics*, 1995, **14**, 3132.
- 37) J. Okuda, *Chem. Ber.*, 1990, **123**, 1649.
- 38) J. Okuda, K. E. du Plooy, W. Massa, H.-C. Kang and U. Rose, *Chem. Ber.*, 1996, **129**, 275.
- 39) K. E. du Plooy, U. Moll, S. Wocadlo, W. Massa and J. Okuda, *Organometallics*, 1995, **14**, 3129.
- 40) H. Plenio and D. Burth, *J. Organomet. Chem.*, 1996, **519**, 269.
- 41) E. Barsties, S. Schaible, M. H. Prosenc, U. Rief, W. Röhl, O. Weyand, B. Dorer and H. H. Brintzinger, *J. Organomet. Chem.*, 1996, **520**, 63.
- 42) R. Fandos, A. Meetsma, J. H. Teuben, *Organometallics*, 1991, **10**, 59.
- 43) Y. Qian and G. Li, *Polyhedron*, 1993, **12**, 967.

- 44) B. Rieger, *J. Organomet. Chem.*, 1991, **420**, C7.
- 45) M. Ogasa, D. T. Mallin, D. W. Macomber, M. D. Rasuch, R. D. Rogers and A. D. Rollins, *J. Organomet. Chem.*, 1991, **405**, 41.
- 46) D. J. Harvan, J. R. Hass, K. L. Buisch, M. M. Bursey, F. Ramirez and S. Meyerson, *J. Am. Chem. Soc.*, 1979, **101**, 7410.
- 47) M. Oberhoff, L. Duda, J. Karl, R. Mohr, G. Erker, R. Fröhlich and M. Grell, *Organometallics*, 1996, **15**, 4005.
- 48) W. A. Hermann, W. Baratta and M. J. A. Morawietz, *J. Organomet. Chem.*, 1995, **497**, C4.
- 49) W. A. Hermann and W. Baratta, *J. Organomet. Chem.*, 1996, **506**, 357.
- 50) D. M. Antonelli, M. L. H. Green and P. Mountford, *J. Organomet. Chem.*, 1992, **438**, C4.
- 51) T.-F. Wang, T.-Y. Lee, Y.-S. Wen and L.-K. Liu, *J. Organomet. Chem.*, 1991, **403**, 353.
- 52) T.-F. Wang and Y.-S. Wen, *J. Organomet. Chem.*, 1992, **439**, 155.
- 53) D. M. Bensley and E. A. Mintz, *J. Organomet. Chem.*, 1988, **353**, 91.
- 54) M. Ogasa, D. T. Mallin, D. W. Macomber, M. D. Rausch, R. D. Rogers and A. D. Rollins, *J. Organomet. Chem.*, 1991, **405**, 41.
- 55) M. Oberhoff, L. Duda, J. Karl, R. Mohr, G. Erker, R. Fröhlich and M. Grell, *Organometallics*, 1996, **15**, 4005.
- 56) See for example: (a) P. M. Maitlis, *Acc. Chem. Res.*, 1979, **11**, 301 and references therein; (b) M. Brookhart and B. E. Grant, *J. Am. Chem. Soc.*, 1993, **115**, 2151; (c) P. I. Djurovich, A. R. Dolich and D. H. Berris, *J. Chem. Soc., Chem. Commun.*, 1994, 1897; (d) W. D. Jones, *Nature*, 1994, **364**, 676 and references therein; (e) P. Jutzi and U. Siemeling, *J. Organomet. Chem.*, 1995, **500**, 175 and references therein.
- 57) P. Jutzi, M. O. Kristen, J. Dalhaus, B. Neumann and H-G. Stammler, *Organometallics*, 1993, **12**, 2980.

- 58) P. Jutzi and U. Siemeling, *J. Organomet. Chem.*, 1995, **500**, 175.
- 59) M. S. Blais and M. D. Rausch, *J. Organomet. Chem.*, 1995, **502**, 1.
- 60) J. Okuda and K. H. Zimmermann, *J. Organomet. Chem.*, 1988, **344**, C1.
- 61) K. H. Zimmermann, R. S. Pilato, I. T. Hovarth and J. Okuda, *Organometallics*, 1992, **11**, 3935.
- 62) J. Okuda, K. H. Zimmermann, *Chem. Ber.*, 1992, **125**, 637.
- 63) R. Poilblanc, *Organometallics*, 1993, **12**, 1503.
- 64) I. Lee, F. Dehan, A. Maisonnat and R. Poilblanc, *Organometallics*, 1994, **13**, 2743.
- 65) P. Jutzi, T. Redeker, B. Neumann and H-G. Stammler, *J. Organomet. Chem.*, 1995, **498**, 127.
- 66) D. Deng, X. Zheng, C. Qian, J. Sun and L. Zhang, *J. Organomet. Chem.*, 1994, **466**, 95.
- 67) D. Deng, X. Zheng, C. Qian, J. Sun and L. Zhang, *J. Organomet. Chem.*, 1994, **466**, 101.
- 68) D. Deng, C. Qian, F. Song, Z. Wang, G. Wu, P. Zheng, S. Jin and Y. Lin, *J. Organomet. Chem.*, 1993, **458**, 83.
- 69) C. Qian, B. Wang, D. Deng and J. Hu, *Inorg. Chem.*, 1994, **33**, 3382.
- 70) P. Jutzi, J. Dalhaus and M. O. Kristen, *J. Organomet. Chem.*, 1993, **450**, C1.

CHAPTER 2

Ligand Synthesis

2.1: Introduction

There are several possible approaches to the synthesis of substituted cyclopentadienyl ligands. One route involves the construction of the five-membered ring around the carbon-chain substituent.¹ An example of this method (taken from reference 1) is shown in figure 2.1.1 and is a variation of one of the standard syntheses of $C_5(CH_3)_5H$. This approach is particularly useful for the synthesis of ligands containing other substituents in addition to the functionalised one, for example ligands based on the $C_5(CH_3)_4R^-$ fragment. This method was not considered for the synthesis of our ligands, since other substituents were not required, the starting materials and reagents are expensive, and the method would not be readily adaptable for the synthesis of indenyl species.

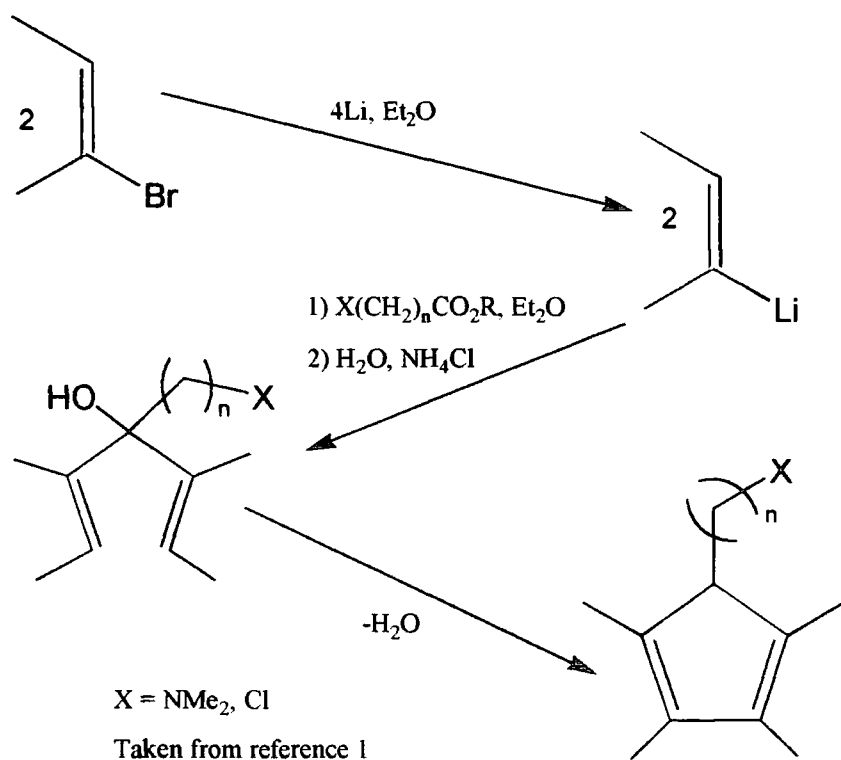

Fig. 2.1.1: Synthesis of a Lewis-base substituted peralkylated cyclopentadiene¹

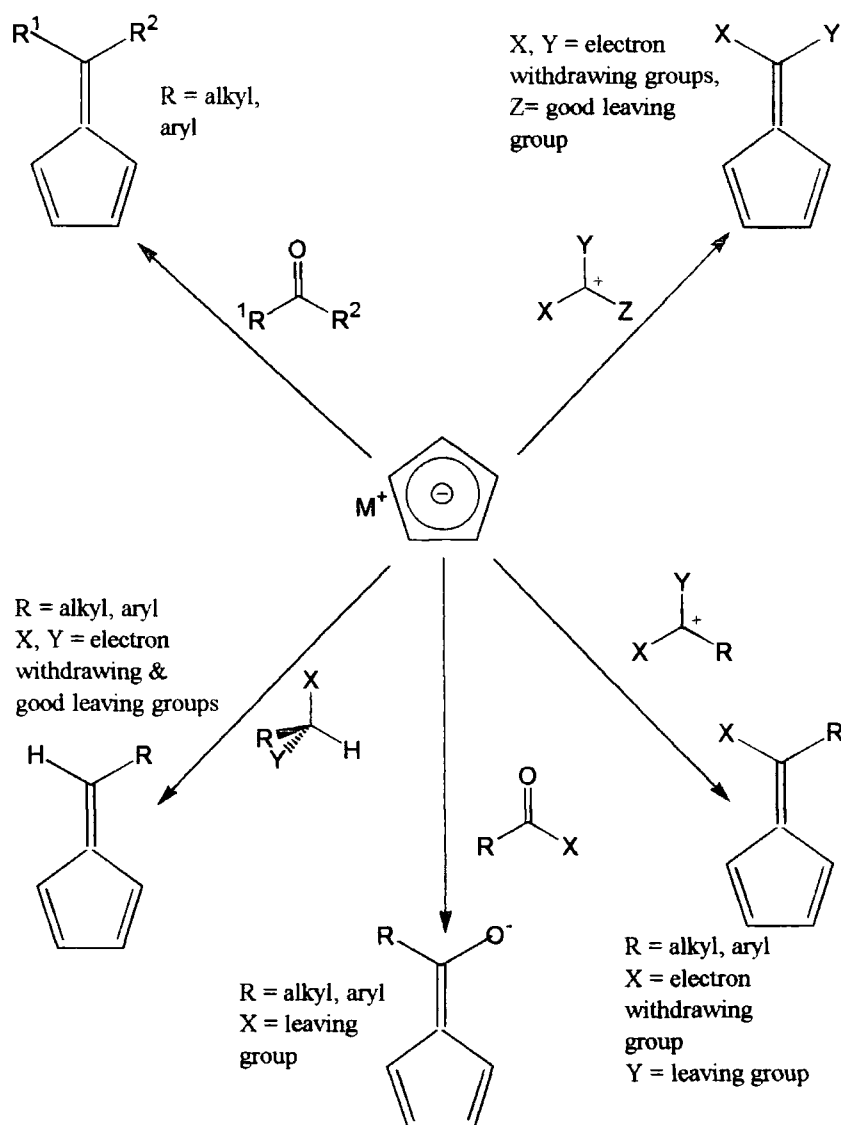
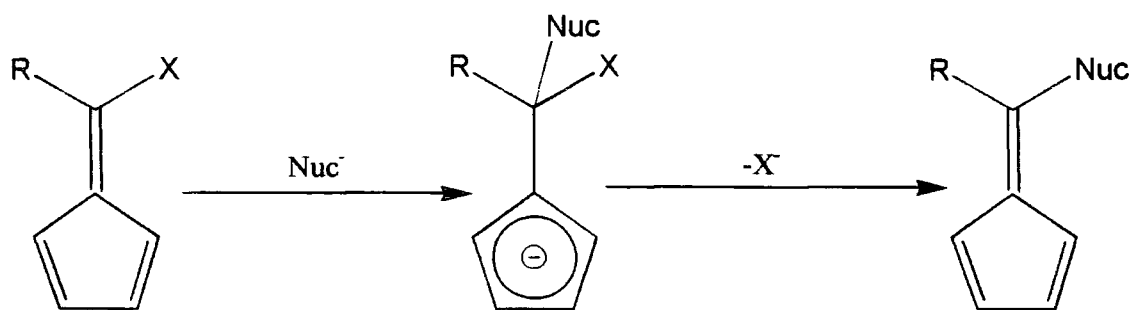

Figure 2.1.2: Routes to pentafulvenes.

In another approach, the use of pentafulvenes as intermediates offers a versatile route to a variety of substituted cyclopentadienyl species. Pentafulvenes themselves can be synthesised by reaction between $C_5H_5^-$ (as an alkali metal salt) and various electrophiles as summarised in figure 2.1.2.² Once synthesised, pentafulvenes can be reduced to the corresponding cyclopentadienes using a hydride reducing agent such as $LiAlH_4$, or they can be reacted with a nucleophile to introduce further substitution as summarised in figure 2.1.3.²



X = good leaving group

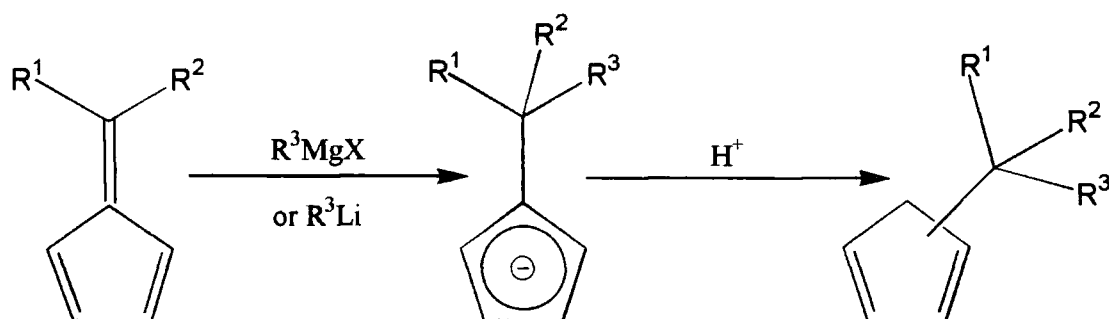

Figure 2.1.3: Introduction of further substituents into fulvenes by nucleophilic attack

Fulvene systems are extremely versatile and can be used in the synthesis of Lewis-base functionalised cyclopentadienes. They are particularly useful in the synthesis of peralkylated phosphine- and amine-functionalised cyclopentadienes as shown in figure 2.1.4.³ In addition, they have been used in the synthesis of vinyl⁴ and pyridyl⁵ species as shown in figures 2.1.5 and 2.1.6 respectively.

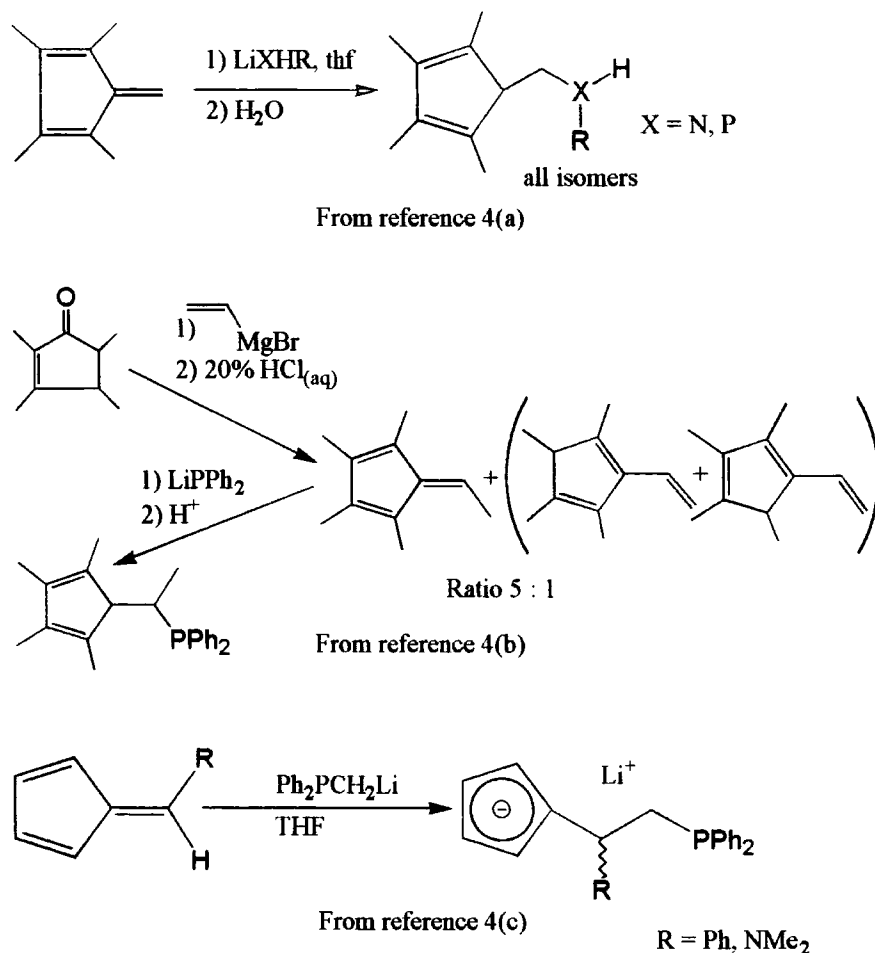

Figure 2.1.4: Phosphine and amine functionalised cyclopentadienes from fulvenes

Indenyl ligands are not easily prepared from fulvenes, although a recent synthesis of an alkyl-substituted indene has been reported and is shown in figure 2.1.7.⁶ However, while this synthesis offers the potential to introduce substituents into the 6-membered ring of indenyl species, we are more interested in putting substituents on the 5-membered ring. It also seems unlikely that this synthesis would tolerate the introduction of Lewis-base functionalities. Reaction of an electrophilic fragment with C₉H₇⁻ still offers the easiest and most versatile route into Lewis-base substituted indenenes.

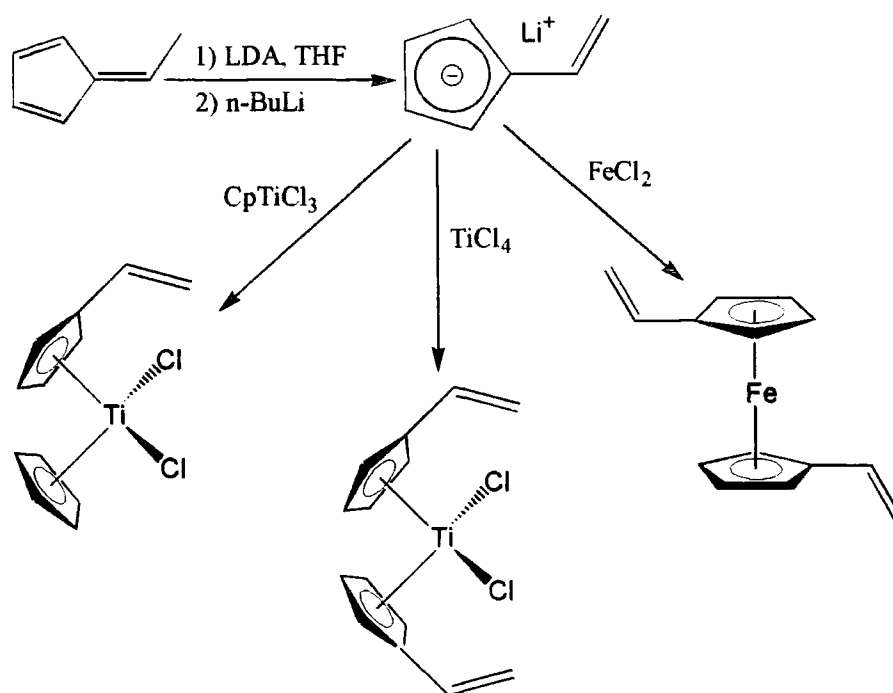

Figure 2.1.5: Vinyl-substituted metal cyclopentadienyls from a fulvene

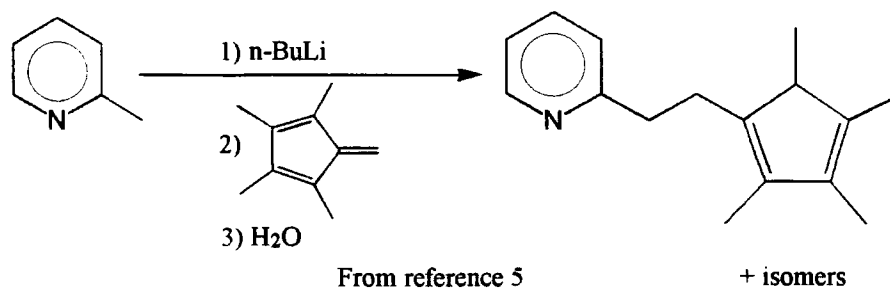

Figure 2.1.6: Synthesis of a pyridyl functionalised tetramethylcyclopentadiene

Since our primary interest is in Lewis-base substituted cyclopentadienes with no further substituents on the ring, and since it was hoped to extend our research into similar indenyl ligands, it seemed best to concentrate on the synthesis of a suitable Lewis-base substituted carbon fragment for coupling with cheap, readily available C_5H_6 ,⁷ C_5H_5Me or C_9H_8 . The adopted ligand synthesis is therefore based on the synthesis of N-substituted-3-halopropylamines which can then react with $C_5H_5^-$, $C_5H_4CH_3^-$ or $C_9H_7^-$.

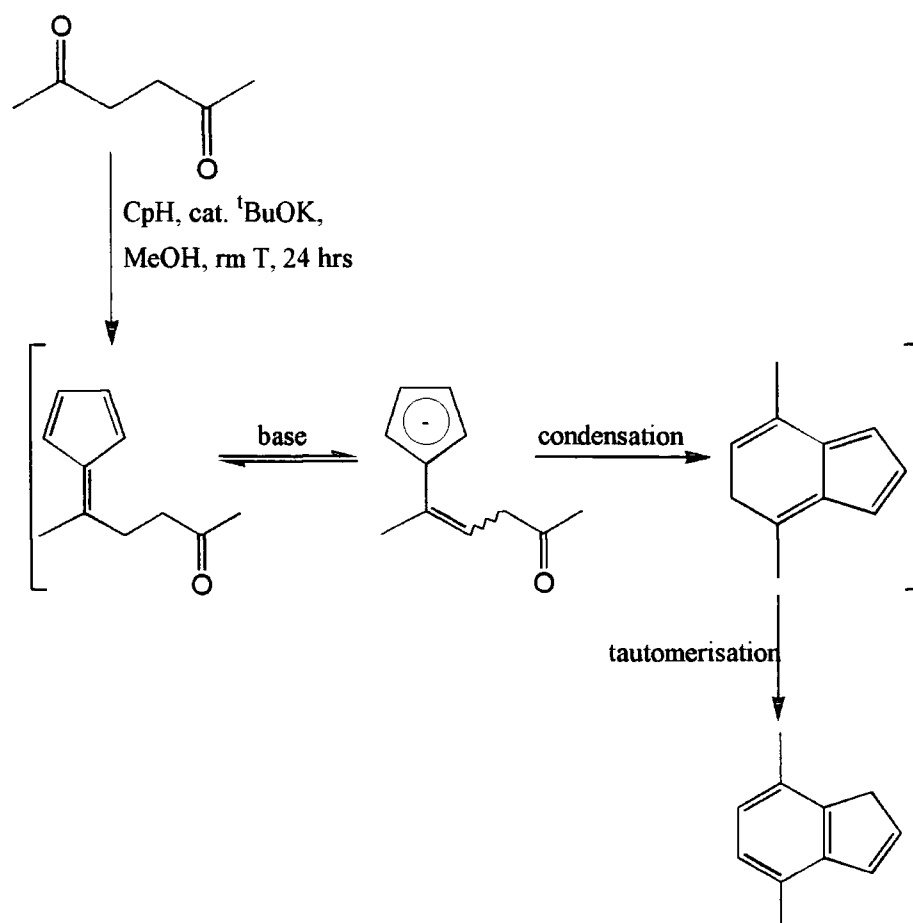

Figure 2.1.7: A substituted indene *via* a fulvene intermediate

2.2: Overview of Ligand Synthesis

The synthesis used was developed from a literature synthesis⁸ and is summarised in figure 2.2.1. Initially, ethyl-3-tertiarybutylaminopropionate was synthesised *via* the conjugate addition of tertiary butylamine to ethyl acrylate. This ester was then reduced to the corresponding alcohol with lithium aluminium hydride. The alcohol functionality was converted to a halide, and the amine group was protonated in the same step. Finally the 3-'butylamino-1-halopropane hydrohalide was coupled with a nucleophilic C₅H₅⁻ or C₉H₇⁻ fragment to give the amine-substituted cyclopentadienyl or indenyl ligand.

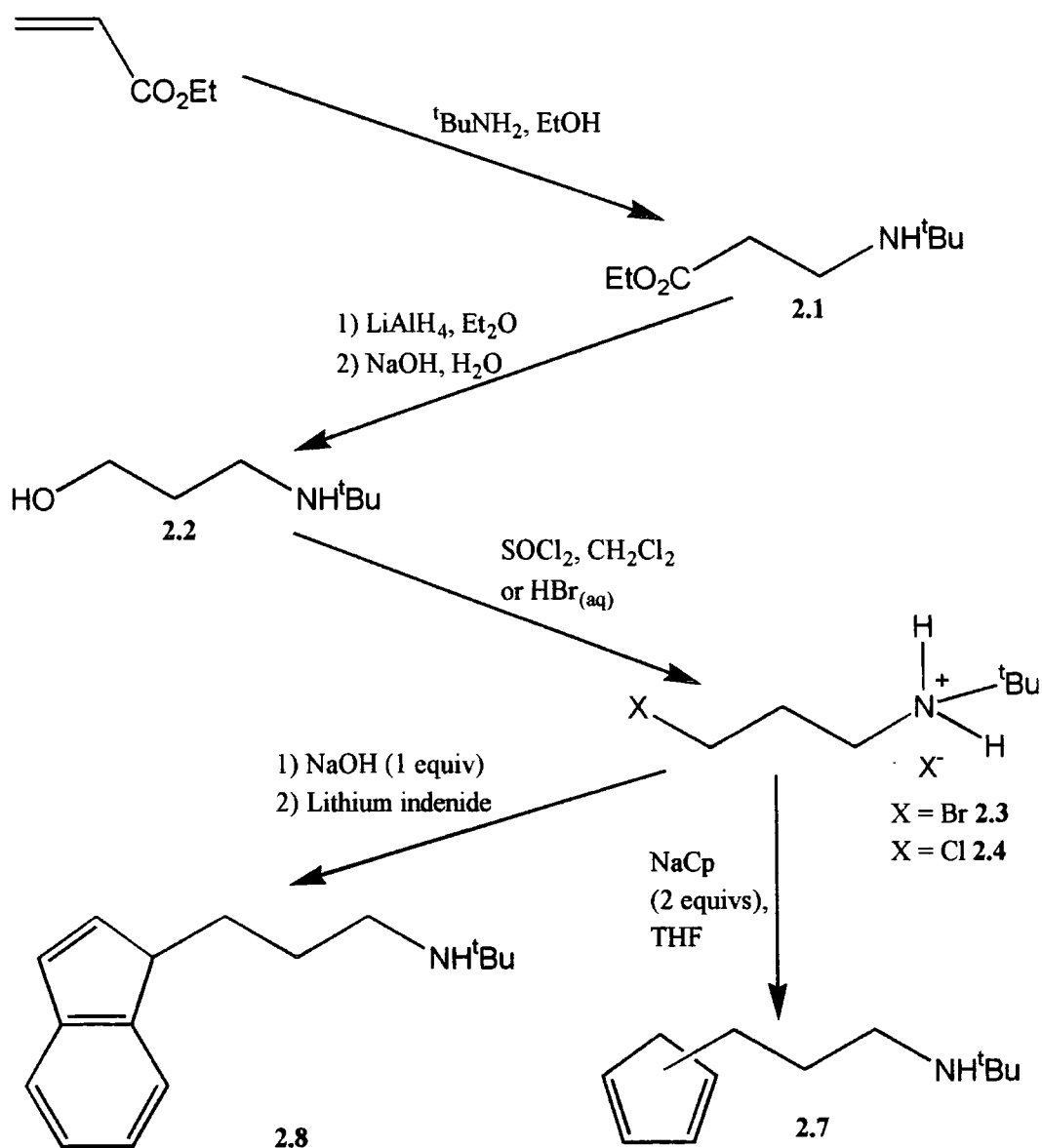
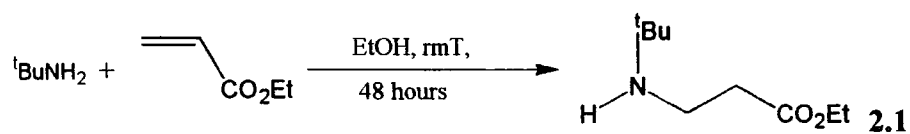

Fig. 2.2.1: Ligand Synthesis

2.3: Preparation of Ethyl 3-Tertiary Butylaminopropionate, 2.1



It is possible to synthesise 3-alkylaminopropan-1-ols from two different precursors. The simplest and most commonly used route is the conjugate addition of a primary amine to ethyl acrylate⁹ shown in figure 2.3.1, giving a 3-alkylaminopropionate ester.

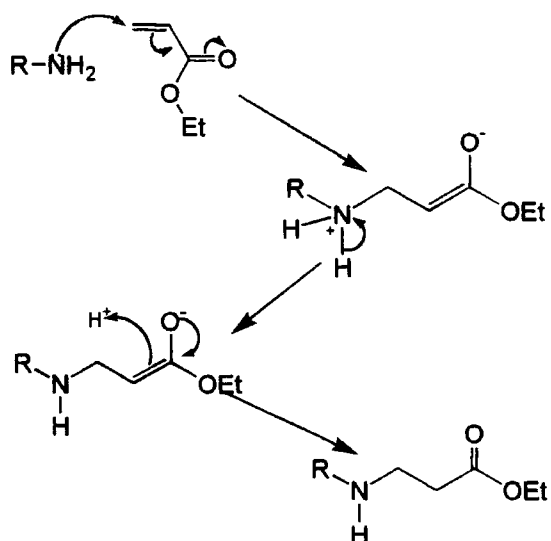

Fig. 2.3.1 Addition of a primary amine to ethyl acrylate

An alternative method shown in figure 2.3.2 is to prepare N-formyl-3-aminopropan-1-ol from ethyl formate and 3-aminopropan-1-ol. This can then be reduced to 3-methylaminopropan-1-ol using LiAlH_4 .¹⁰ Although this reaction has the potential to be adapted for synthesis of species other than 3-methylaminopropan-1-ol, it can only be used to produce systems in which the N-substituent contains a CH_2 group. Hence this method would not be suitable for 3-^tbutylaminopropan-1-ol.

The ethyl formate route is advantageous for the synthesis of compounds with small substituents on the amine group, when the ethyl acrylate route produces a low yield of the desired product and large quantities of a useless side product as shown in figure 2.3.3. However, as is discussed in more detail below, it was hoped that the use of a bulkier amine would eliminate this problem from the acrylate reaction. The acrylate method uses cheaper and more readily available starting materials, and so is the method of choice if the disadvantages can be overcome.

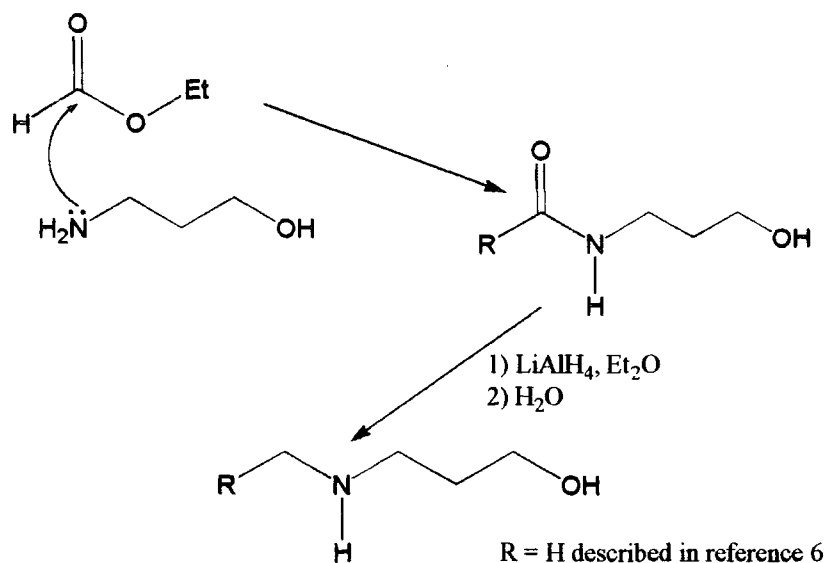

Fig. 2.3.2: Alternative synthesis of N-alkyl-3-hydroxypropylamine from ethyl formate

It was noted by the original workers⁴ and later by members of our group⁷ that the addition of methylamine to ethyl acrylate gave the desired mono-substituted product in moderate yield (31%) together with a similar quantity of the undesired di-substituted product as shown in figure 2.3.3. The di-substituted product is produced exclusively under certain reaction conditions.¹¹ Bulkier amines are known to give a higher yield of the desired product⁴ and it was hoped that use of tertiary butylamine would maximise the yield of this initial step.

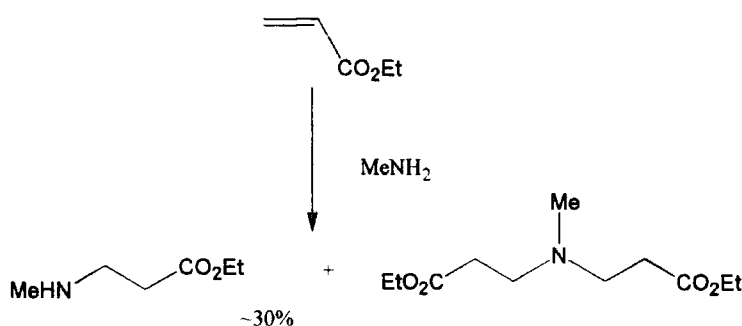

Fig. 2.3.3: Formation of undesirable side-product in the reaction between methylamine and ethyl acrylate

Reaction in ethanol between ethyl acrylate and ^tbutylamine at room temperature over 48 hours and subsequent removal of solvent yielded a large quantity of a colourless oil, 2.1. Reduced pressure distillation of this oil yielded a single fraction which was shown by ¹H and ¹³C{¹H} NMR spectroscopy to be the desired product. Later work showed that the distillation step is unnecessary; if good quality starting materials are used, removal of the solvent will yield analytically pure product without further purification. Typically, the yield for this reaction was >95% of 2.1, which is extremely good and exceeds the literature yield of 78%.⁹

It is concluded that addition of tertiary butylamine to ethyl acrylate is a clean and simple method for building an amine-functionalised three-carbon chain. If the ethyl formate route could be adapted to prepare a tertiary butylamino species, it is doubtful whether the yield and efficiency would match that of the acrylate reaction. Even if our yields had only matched those given in the literature, this reaction would still represent a highly satisfactory first step in the multi-step ligand synthesis, since as well as being clean and of exceptionally high yield, the reaction can be carried out on a very large scale (typically ~90g were made at a time) with no adverse effect on the yield or purity of the product.

2.4: Variation of the N-Substituent

The ethyl acrylate reaction offers limited potential for varying the N-substituent. The problems encountered when the starting amine has only a small substituent group have already been discussed. The synthesis of ethyl 3-phenylaminopropionate by this method proved impossible as the reaction between phenylamine and ethyl acrylate (figure 2.4.1) yielded only unreacted starting materials even after prolonged reflux. Variations of solvent,

temperature and reaction time failed to produce the desired reaction, as did the use of lithium phenylamide instead of the free phenyl amine.

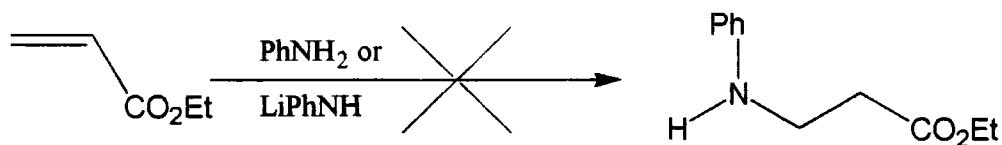

Fig. 2.4.1 Unsuccessful reaction between ethyl acrylate and phenylamine

Acrylonitrile is known to react cleanly and in high yield with aromatic as well as aliphatic amines.¹² This reaction may prove to be a useful first step in the synthesis of N-phenylaminopropyl species, since the resulting nitrile could be converted into the corresponding carboxylic acid by hydrolysis and then converted *via* the steps shown in figure 2.4.2 into a cyclopentadiene ligand. A phenyl substituent on the amine nitrogen may have an interesting and useful effect on the reactivity, solubility and crystallinity of various organometallic species, which could outweigh the difficulties which might be encountered in using toxic acrylonitrile as a starting material.

An attempt was also made to synthesise a linked species by reaction between ethyl acrylate and ethylenediamine as shown in figure 2.4.3. It was hoped that this reaction, if successful, could have been used as a first step in the synthesis of a linked cyclopentadiene with two amino groups incorporated into the backbone. However, ethylenediamine did not react with ethyl acrylate in the desired manner, probably because ethylenediamine is not bulky enough to prevent the formation of various side products. A highly complex mixture of products was formed from the reaction which proved to be too close in boiling point to be separated by fractional distillation.

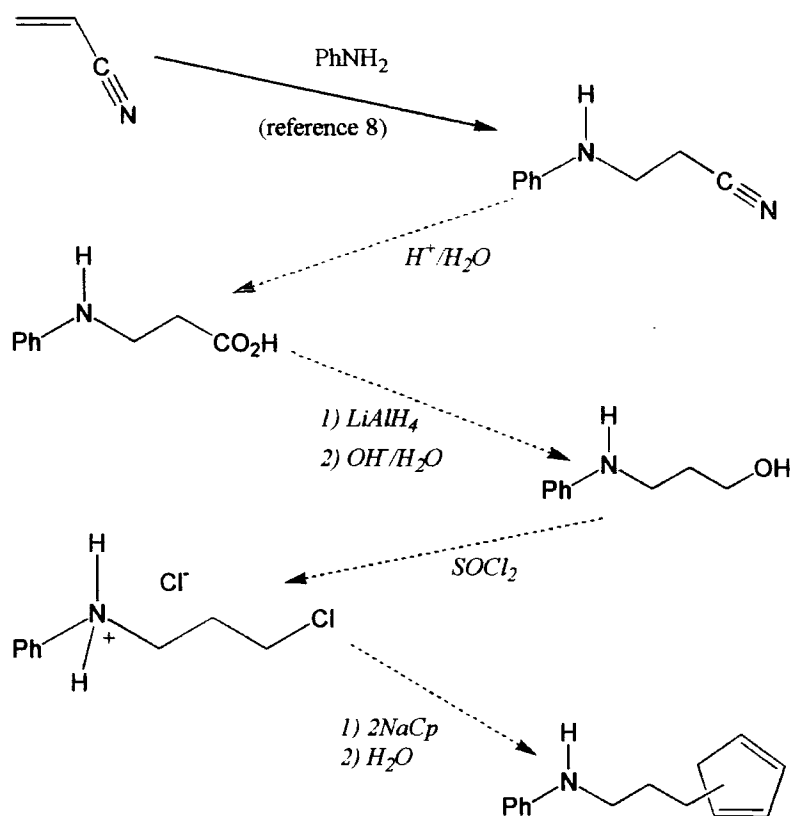

Fig. 2.4.2: Proposed synthetic route to N-phenylaminopropyl cyclopentadiene

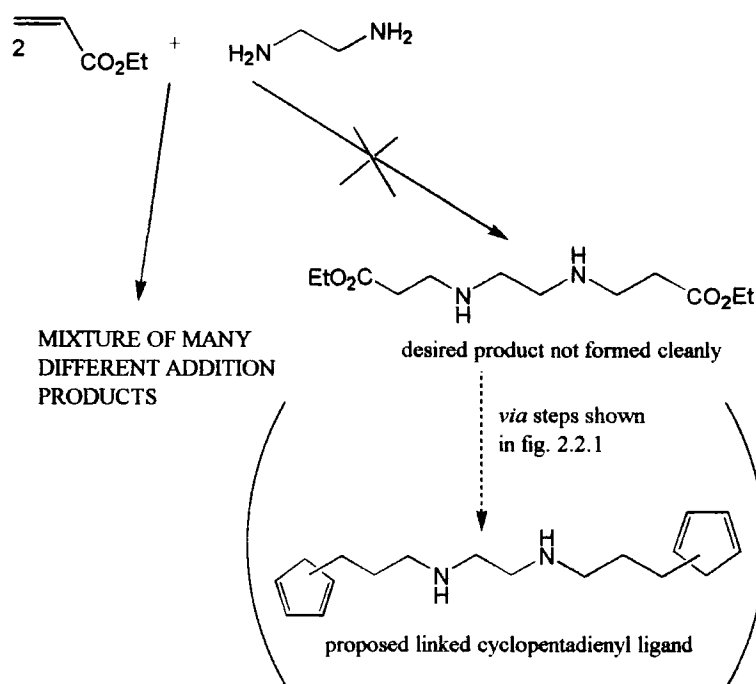

Figure 2.4.3: Reaction between ethylenediamine and ethyl acrylate

2.5: Introduction of Substituents into the Carbon Backbone

Members of our group have attempted to use the addition of an amine to a conjugated ester to introduce substituents into the carbon backbone of N-substituted aminopropyl species. Reaction between methylamine and ethyl-*trans*-cinnamate¹³ yielded a mixture of products, from which a small amount of the desired amino ester was isolated. This was subsequently reduced to the corresponding alcohol and converted into the chloride and thence into the cyclopentadiene. However, the quantity of cyclopentadiene which could be produced by this method was very small, which caused difficulties when synthesis of organometallic species was attempted. Recent literature indicates that cinnamate esters will undergo clean, high yield addition reactions with lithiated amines, (figure 2.5.1)¹⁴ and this may represent a better route to species with phenyl substituted backbones.

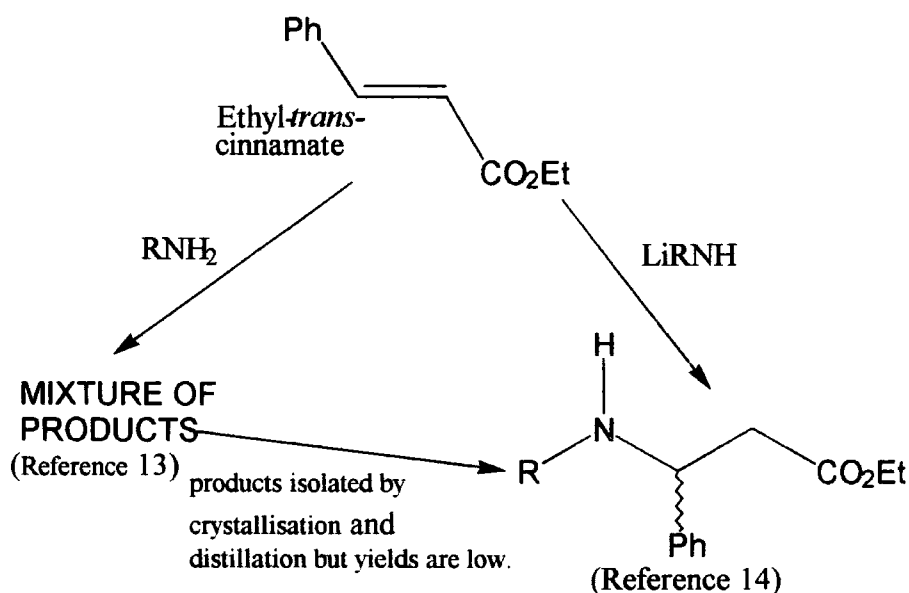

Fig. 2.5.1: Reaction between amines and ethyl-*trans*-cinnamate

Alternatively, the condensation reaction between benzaldehyde and malonic acid in the presence of ammonia to yield cinnamic acid and β -aminocinnamic acid (figure 2.5.2)¹⁵ can be adapted for the synthesis of N-substituted β -aminocinnamic acids. For example, the condensation reaction between malonic acid and benzylidenemethylamine gives N-methyl- β -aminocinnamic acid in 52.5% yield, along with *trans*-cinnamic acid in 34% yield.¹⁶ The major snag with this type of reaction is that the relative yields of the two acids are unpredictable and difficult to control.

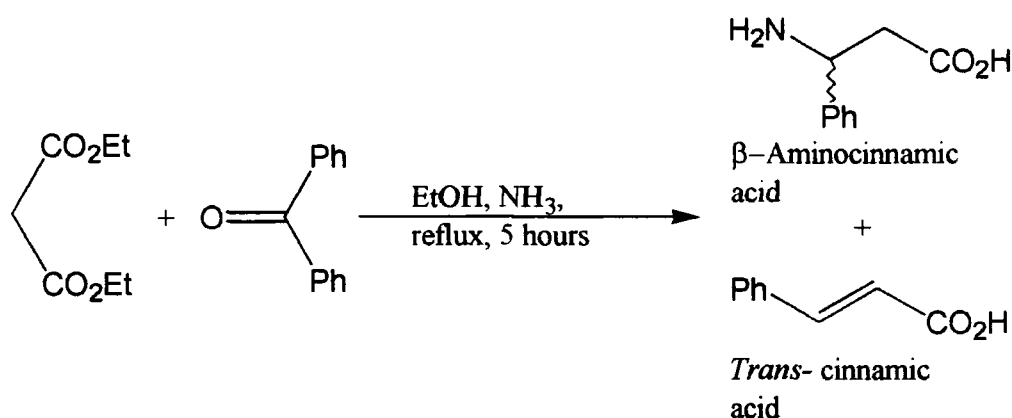

Fig. 2.5.2: Reaction between malonic acid, benzaldehyde and ammonia.

It is known that both crotonates and methacrylates react with amines, although requiring more vigorous conditions than acrylates, and this is another route into species with substituted backbones (figure 2.5.3).¹⁷ Once the esters have been synthesised it should prove possible to use them to synthesise substituted cyclopentadienes *via* steps shown in figure 2.2.1.

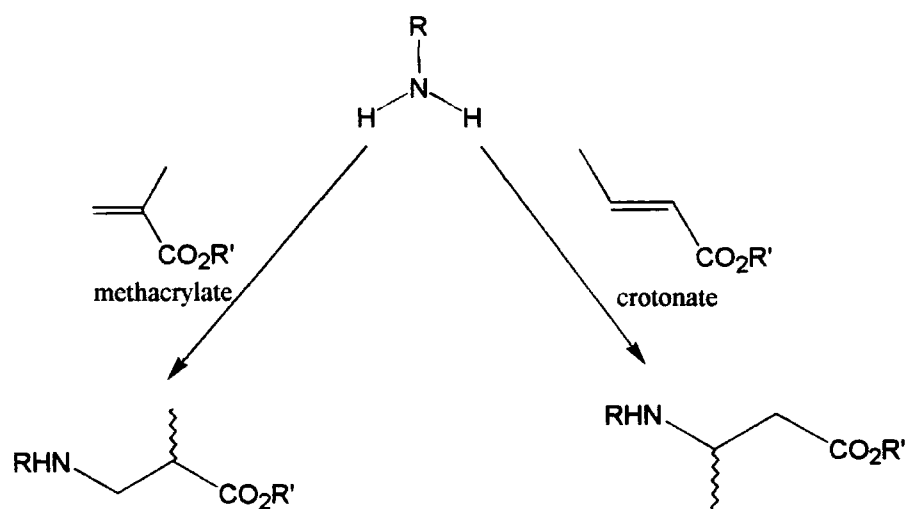
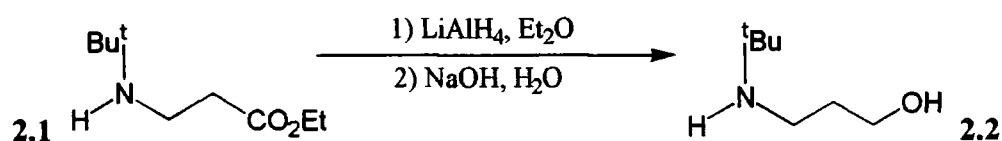

Fig. 2.5.3: Reaction between amines, methacrylates and crotonates

2.6: Preparation of 3-Tertiarybutyl Aminopropan-1-ol, 2.2



The reduction of 3-alkylaminopropionates to the corresponding alcohols can be accomplished using LiAlH_4 followed by aqueous work-up. The original researchers achieved moderate yields (78% for *t*-butyl,⁵ 38%⁵ or 48%¹⁸ for methyl), but later work on the reduction of the methylamino compound produced lower yields, *c.a.* 28%.⁷

Initially, the reduction of 2.1 with LiAlH_4 gave a reasonable yield (40%) of the product alcohol, 2.2. However, when the reaction was scaled up the yield dropped dramatically to <20%. It was necessary to improve the efficiency of this step if at all possible, since it was hoped to be able to prepare the final cyclopentadiene on a 20-30g scale, and by following the literature method it was only possible to make between 5 and

10g of this intermediate in a single reaction.

Unlike similar, straight-chain N-substituted amino alcohols described in the literature,⁵ which are oils, **2.2** is a crystalline solid, readily soluble in diethyl ether. It was discovered that a large percentage of the product formed was becoming adsorbed onto the solid $\text{Al}_2\text{O}_3 \cdot n\text{H}_2\text{O}$ produced during the aqueous work up, so that ether extraction was removing only small quantities. To overcome this problem, the work-up was carried out using saturated aqueous NaOH solution, rather than water. This required a great deal of care due to the vigorous reaction between unreacted LiAlH_4 and NaOH, but the high pH caused most of the hydrolysis products to dissolve in the aqueous layer. Typically, sufficient NaOH was added to maintain the pH at around 14.

Extraction of the aqueous layer with several portions of diethyl ether followed by removal of the solvent gave the desired alcohol **2.2** as a white, crystalline solid in >80% yield. This product proved to be analytically pure without recrystallisation.

2.7: Preparation of 3-Tertiarybutyl Amino-1-Bromopropane Hydrobromide 2.3

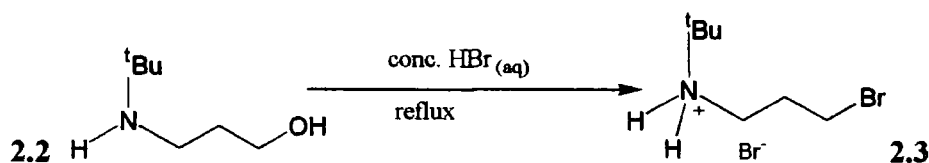

The synthesis of 3-alkylamino-1-bromopropanes as their hydrobromides was based on the preparation of 2-aminobromoethane first described by Gabriel.¹⁹ This compound was originally prepared by sealing ethanolamine into a glass tube with an excess of 48% aqueous HBr and heating to 170°C. The reaction was later shown to take place rapidly and in high yield at atmospheric pressure with no heating.²⁰ An improved version of the same procedure was used for the preparation of similar compounds of the type shown in figure

2.7.1 which contain a tertiary amino group.²¹ Other methods for the preparation of 2-aminobromoethane include the reactions between concentrated aqueous HBr and potassium phthalimide²² or ethyleneimine.²³ However, neither of these methods seem particularly adaptable for the synthesis of compounds which contain longer carbon chains and/or secondary or tertiary amino groups. Moreover, the starting materials are not as easily available as the amino alcohols.

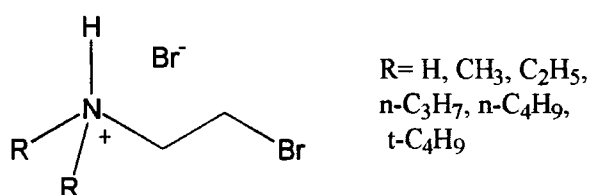

Fig. 2.7.1

The experimental procedure described in reference 21 was used as the basis for the preparation of 3-methylamino-1-bromopropane hydrobromide by Hughes,⁷ and the same procedure was used for the preparation of 3-tertiarybutylamino-1-bromopropane hydrobromide **2.3**, with a few notable differences. Due to the fact that **2.2** is a solid (unlike the various amino alcohols described in the literature), 48% aqueous HBr was added dropwise to the alcohol rather than the other way round. This did not significantly affect the final yield and is more convenient and controllable than the addition of a solid to a liquid.

Previously it has been found that 3-methylamino-1-bromopropane hydrobromide can be difficult to obtain in pure, crystalline form.^{7, 24} However, pure, crystalline **2.3** was obtained quite easily by dissolving the crude product in the minimum quantity of boiling acetonitrile, filtering and cooling to -30°C in stages. The white, needle-like crystals were

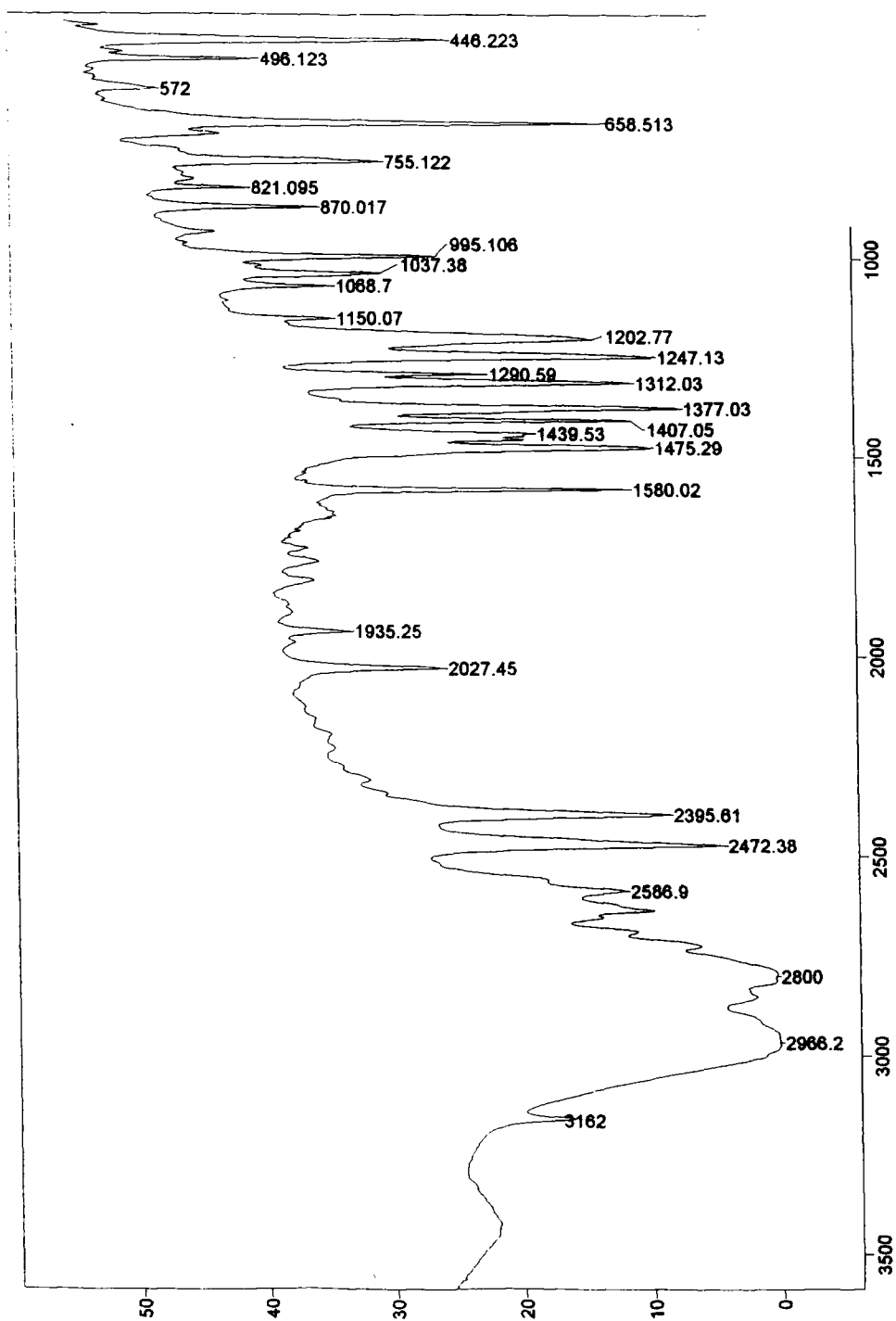
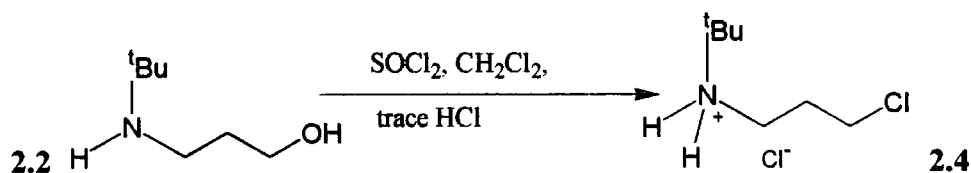

Figure 2.7.2: IR spectrum of 2.3 (as KBr disc) after recrystallisation and prolonged drying

then filtered, washed in ether and dried under reduced pressure. However, due to the aqueous reaction conditions and the mildly hygroscopic nature of this compound, it was very difficult to obtain a sample which was completely dry (the IR spectrum of a sample of this compound taken after prolonged drying is shown in figure 2.7.2 and still shows strong water absorptions) and this may account in part for the problems experienced when this compound was used in the attempted synthesis of the cyclopentadiene.

2.8: Preparation of 3-Tertiarybutyl Amino-1-Chloropropane Hydrochloride, 2.4



Compound 2.3 was the initial choice of precursor for the preparation of the substituted cyclopentadienyl and indenyl species. However, due to problems described in section 2.7, this route had to be abandoned in favour of an alternative. One possibility was to convert the alcohol 2.2 to a tosylate, since it is known that treatment of 3-methylaminopropan-1-ol with tosyl chloride in pyridine gives the corresponding tosylate in high yield.²⁵ However, a simpler and cheaper alternative to both the bromide and the tosylate is the chloride. The method used for preparation of 3-tertiarybutylamino-1-chloropropane hydrochloride 2.4 is based upon the literature method for preparing N-dimethyl-2-chloroethylamine hydrochloride.

Addition of neat thionyl chloride to solid 2.2 initially produced, on work-up, a 78% yield of 2.4, which after recrystallisation from boiling ethanol and subsequent thorough washing with light petroleum was sufficiently pure to be used in the next stage of the

synthesis. However, the third time this reaction was carried out, a problem emerged. Reaction between the product from this reaction and sodium cyclopentadienide yielded a much smaller yield of the desired product than previous runs (28%), and a correspondingly higher yield of N⁴-butylazetidine, **2.6**, which it had been noted was always present as a minor impurity. NMR analysis of the materials used indicated that the azetidine was not forming during the reaction between the chloride and sodium cyclopentadienide, but was already present as a major impurity formed during the reaction between **2.2** and SOCl₂. The ¹H NMR spectrum of this contaminated compound is shown in figure 2.8.2. It was noticed that previous preparations of the chloride **2.4** had been carried out using SOCl₂ which was several years old and had been exposed to moisture over a long period of time and therefore contained a substantial amount of HCl impurity. The problem of azetidine formation arose when a brand new bottle of dry thionyl chloride was used. It is thought that pure, dry SOCl₂ reacts with solid alcohol to form free 3-⁴-butylamino-1-chloropropane, **2.5**, and HCl, but the HCl forming in this reaction was escaping from the mixture as a gas (due to the absence of solvent and the rise in temperature caused by the exothermic reaction) and so was not available to protonate the amine. On refluxing in ethanol (to destroy excess SOCl₂), **2.5** was undergoing ring-closure to form N⁴-butylazetidine **2.6**. A suggested mechanism for this reaction, which is blocked by protonation of the amine, is shown in figure 2.8.1.

To prevent formation of this side product, in subsequent preparations **2.2** was dissolved in CH₂Cl₂ and a few drops of concentrated (~10M) aqueous HCl were added to begin protonation of the amine nitrogen. On addition of excess SOCl₂, sufficient HCl was evolved from reaction with water present in the mixture to ensure complete protonation of the amine nitrogen as well as conversion of the hydroxy group into a chloride. The use of a CH₂Cl₂ solution of **2.2** rather than solid **2.2** allowed more efficient stirring of the reaction

mixture and significantly reduced loss of HCl gas from the mixture. After stirring the mixture overnight in a fume hood, removal of the solvent followed by refluxing in ethanol for 2 hours gave a good yield (typically 74%) of crystalline **2.4**. This was washed in light petroleum and dried under reduced pressure. NMR studies showed that only a trace of N-^tbutylazetidone was present. The ¹H and ¹³C{¹H} NMR spectra of this compound are shown in figures 2.8.3 and 2.8.4 respectively.

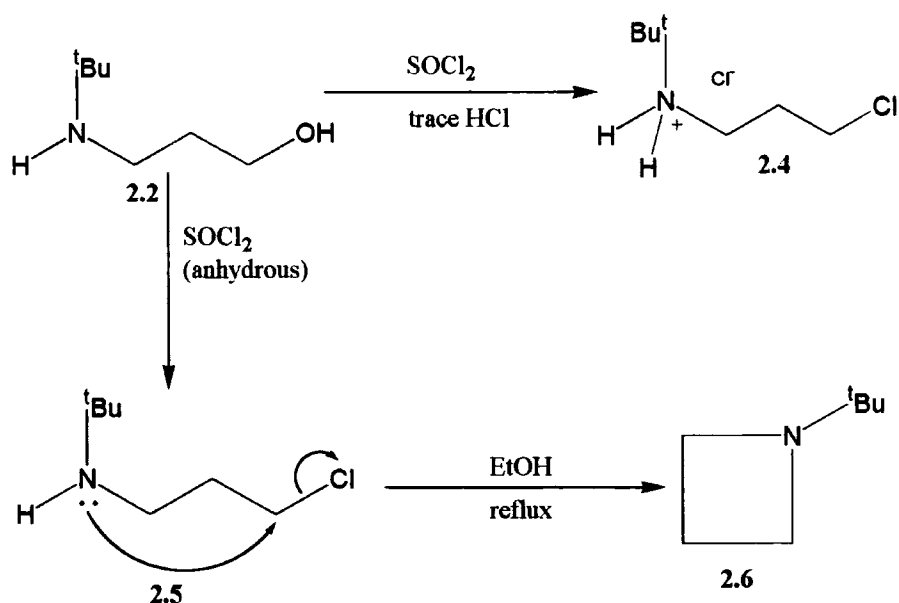

Fig. 2.8.1: Formation of N-^tbutylazetidone side-product

Other workers in this group have experienced problems in obtaining pure, crystalline samples of analogous compounds.²⁶ A dry, azetidone free, analytically pure sample of **2.4** can be obtained by recrystallising the product a second time from the minimum quantity of boiling acetonitrile. It is noticeable that both **2.3** and **2.4** are considerably more crystalline and hence easier to purify than analogous compounds synthesised by this research group, particularly those with methyl substituents on the amine group.^{8, 13, 24, 26}

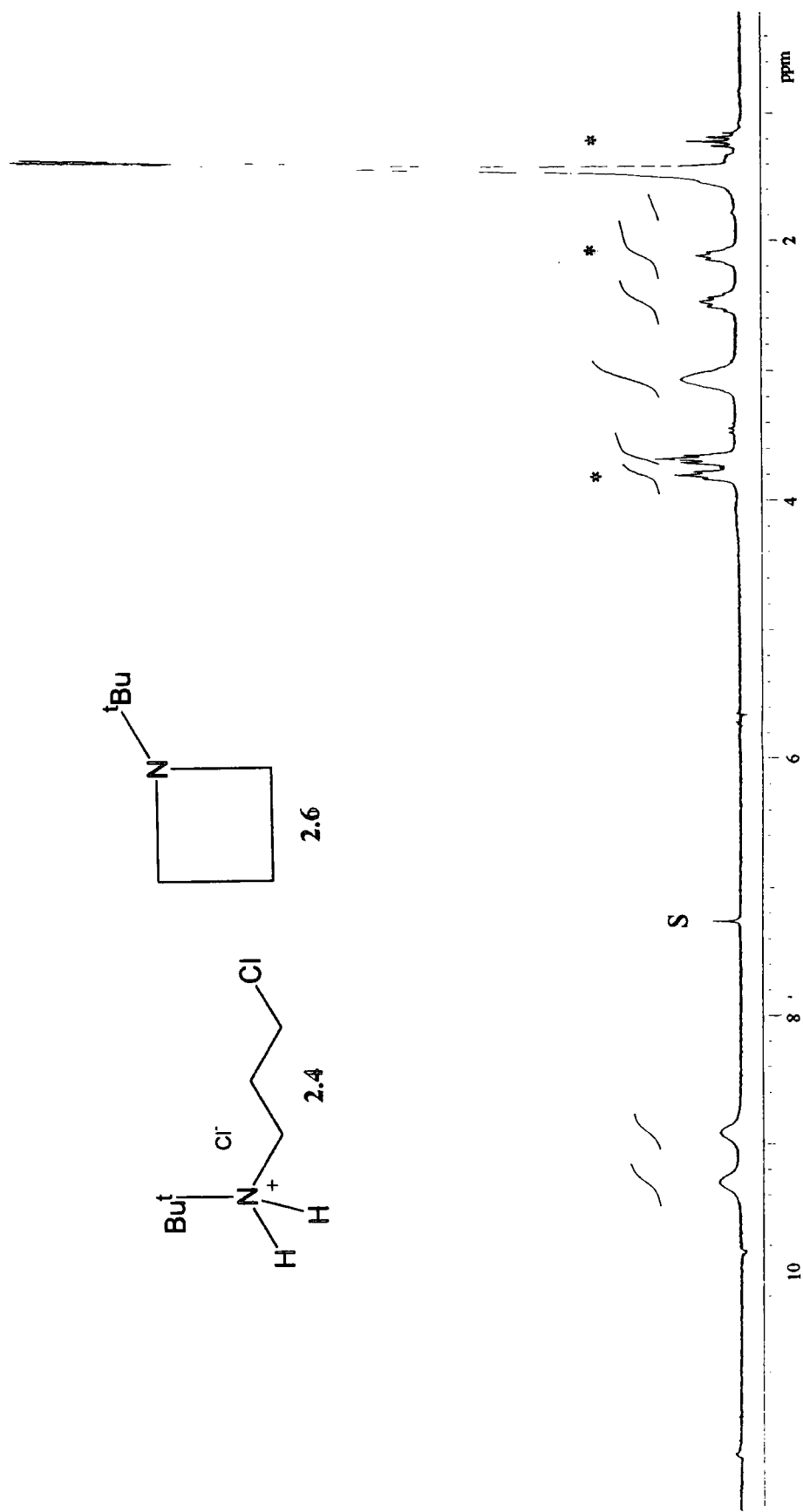

Figure 2.8.2: The ^1H NMR spectrum of 2.4 at 200MHz in CDCl_3 with N'-butyl azetidinium (2.6) impurity marked * and solvent peak marked S

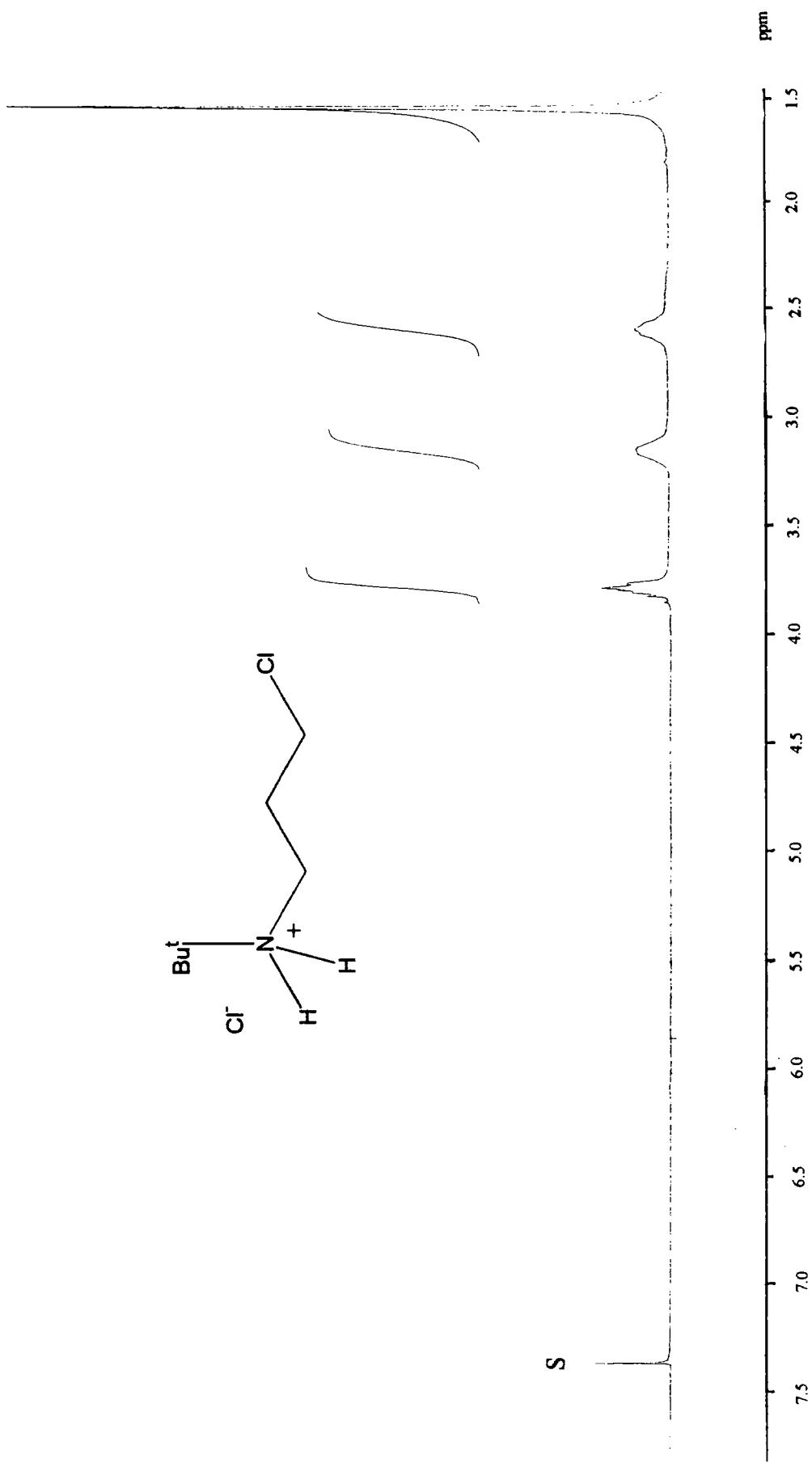

Figure 2.8.3: The ^1H NMR spectrum of pure 2.4 at 250MHz in CDCl_3 (marked S)

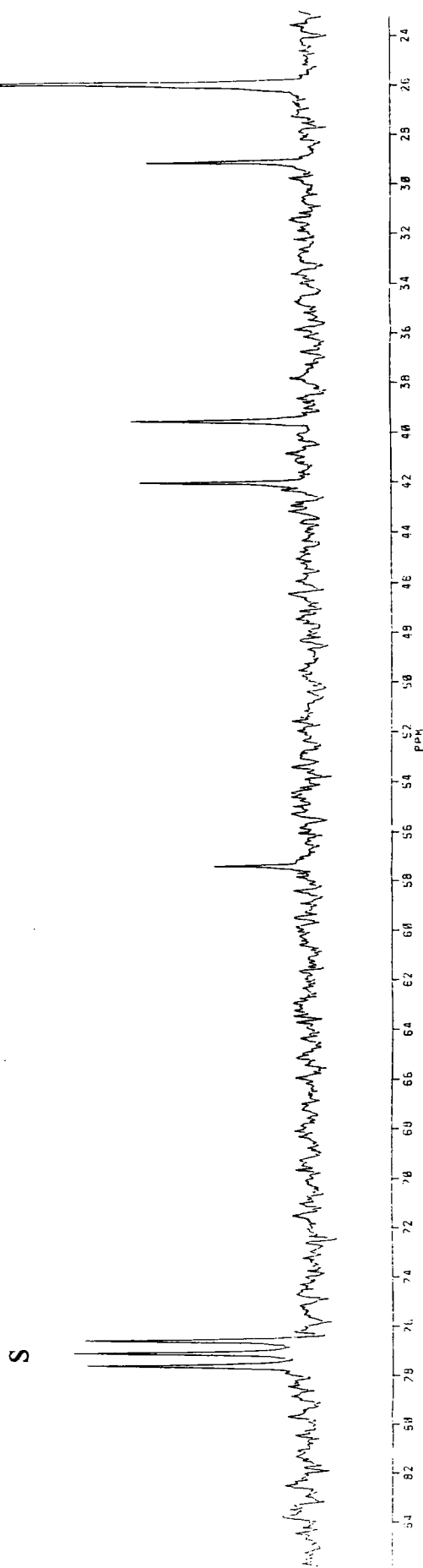
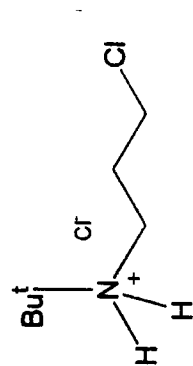
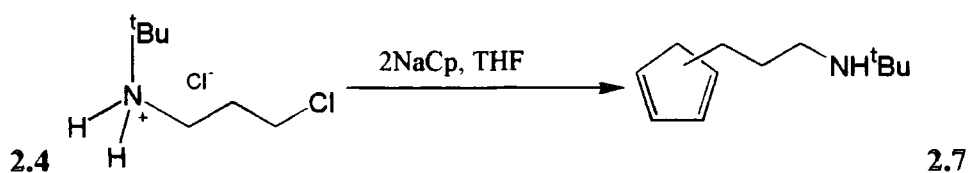

Figure 2.8.4: The ¹³C{¹H} NMR spectrum of pure 2.4 at 62.5 MHz in CDCl₃ (marked S)

2.9: Preparation of N-Tertiarybutylaminopropyl Cyclopentadiene, 2.7



Initially it was hoped to synthesise the desired cyclopentadiene using 3-^tbutylamino-1-bromopropane hydrobromide **2.3** as a precursor. However, addition of two equivalents of sodium cyclopentadienide to a THF solution of **2.3** followed by refluxing for 4 hours yielded no characterisable products after work-up. The reaction was repeated several times with different combinations of solvent, reaction temperature and time, but the desired product could not be obtained by this method. It is not certain why this is the case, since the reaction between 3-methylamino-1-bromopropane hydrobromide and sodium cyclopentadienide under similar conditions yields the substituted cyclopentadiene in good yield.^{7, 8} It is possible that trace amounts of water present in the bromide might have been interfering with the reaction. However, whilst it would be reasonable to attribute a lowering of yield to trace moisture, it is difficult to see how such a small amount of water (detectable by IR spectroscopy only, not visible in ¹H NMR spectra) could totally inhibit formation of the cyclopentadiene **2.7**. Some earlier preparations of similar compounds were carried out with HMPA present in the reaction mixture to promote nucleophilic attack.²⁷ However, in view of the high toxicity of HMPA and the fact that its presence had been shown to be unnecessary in a similar reaction,^{7, 8} it was hoped that its use could be avoided.

Addition of two equivalents of sodium cyclopentadienide to a THF solution of 3-^tbutylamino-1-chloropropane hydrochloride **2.4** caused formation of a fine, white precipitate in the pink reaction mixture. Refluxing for 4 hours followed by aqueous work-up (described fully in Chapter 7) gave a dark brown, free flowing oil. On allowing this oil to

stand for a few hours, a small quantity (<5% of total yield) of N^t-butylazetidene crystallised and was removed by filtration. NMR spectroscopy showed the remaining oil to be a mixture of all three possible isomers of the substituted cyclopentadiene, **2.7**, together with trace impurities. GC-MS confirmed that all three isomers were present, since the GC trace showed three strong peaks with masses of 179. GC-MS also identified the impurities as cyclopentadiene and dicyclopentadiene.

The impurities were removed in two ways. Samples of the compound which were sufficiently pure for use in the synthesis of organometallic species were obtained by protonating the amine group using dilute HCl to form a salt which was extracted into water, leaving impurities behind in the organic layer. The salt was then converted back to the free amine by addition of NaOH solution followed by extraction back into petrol or diethyl ether. An analytically pure sample of the cyclopentadiene, **2.7**, was obtained by reduced pressure distillation, but this was less convenient because high temperatures were required and could cause decomposition. The ¹H NMR of the substituted cyclopentadiene is shown in figure 2.9.1.

Two equivalents of sodium cyclopentadienide are required for the reaction since one equivalent is used to convert the amine hydrochloride, **2.4**, to the analogous free amine together with sodium chloride and cyclopentadiene. The majority of this cyclopentadiene could be removed under reduced pressure together with the solvent and any remaining traces were removed at the protonation stage.

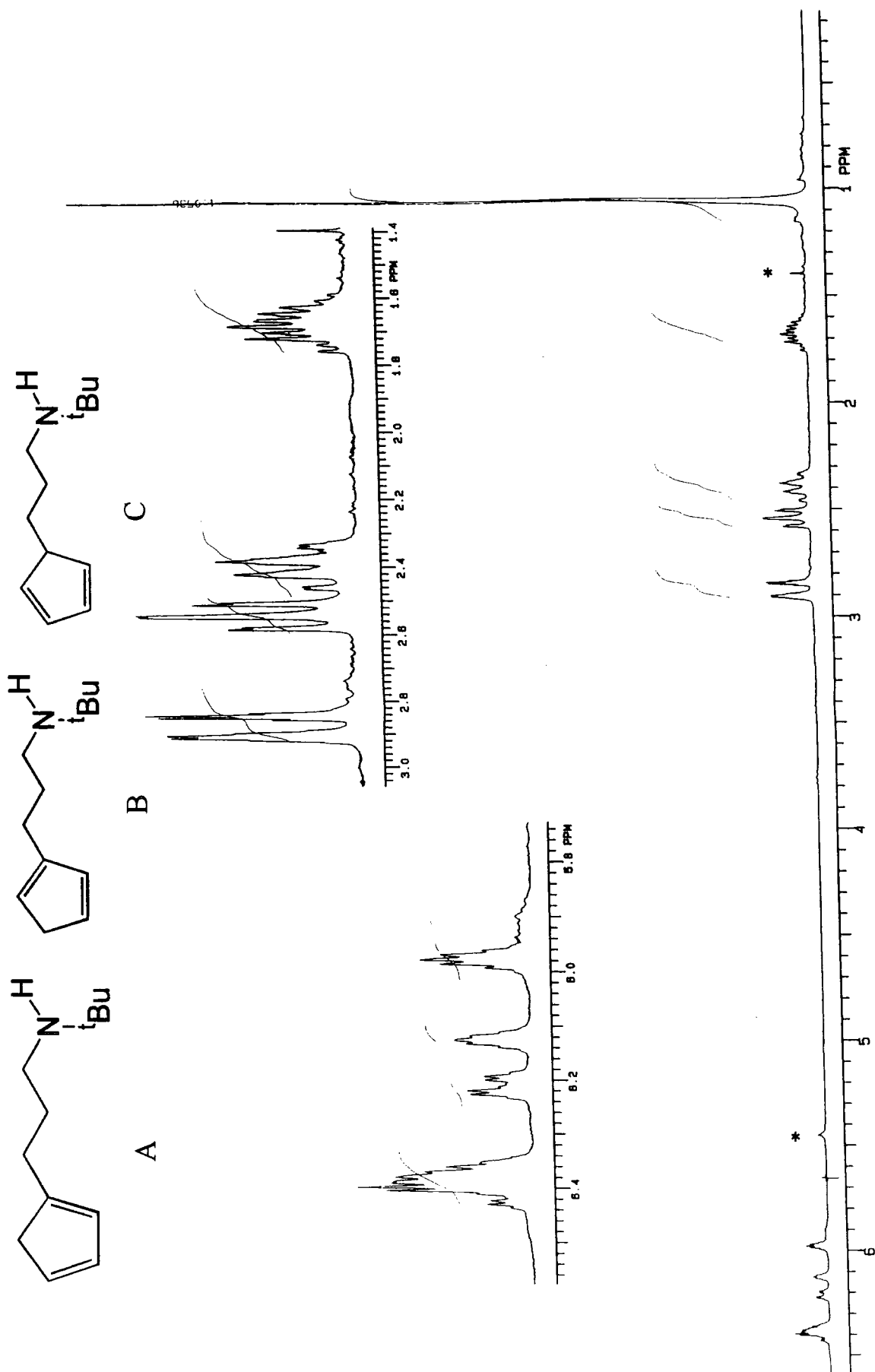
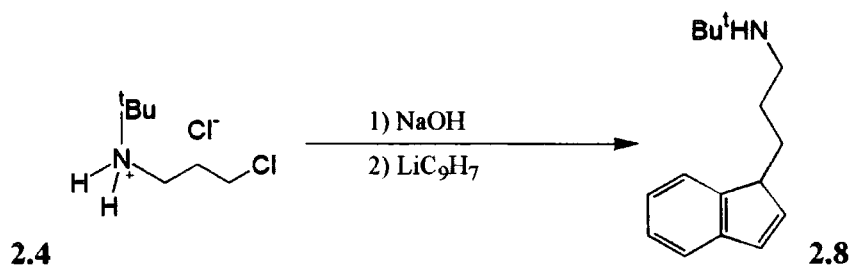

Figure 2.9.1: ^1H NMR spectrum of the substituted cyclopentadiene 2.7 at 200MHz in CDCl_3 with impurities marked *

2.10: Preparation of N-Tertiary Butylaminopropyl-2-indene, 2.8



The amine-substituted indene, **2.8**, was prepared in a similar way to the cyclopentadiene, from **2.4** and lithium indenide. However, since lithium indenide (prepared from indene and ⁿbutyl lithium) is considerably more costly than sodium cyclopentadienide, it is preferable not to have to use two equivalents in the reaction. It would also be very difficult to remove the resulting C₉H₈ from the final product, since this compound is not volatile enough to be removed with the solvent and the amine-substituted indene cannot be protonated. This is discussed in more detail below.

These difficulties were avoided by deprotonating **2.4** using saturated aqueous NaOH solution. The free chloride, **2.5**, was then extracted with toluene and added to a THF solution of lithium indenide as soon as possible. The free chloride, **2.5**, appears to be stable at room temperature for several hours, but heat or prolonged storage will cause ring-closure to give N-^tbutylazetidene (for a full discussion see section 2.6, for experimental details and safety note see section 5.2.6). After addition of **2.5**, the reaction mixture was refluxed for 4 hours. Aqueous work-up (following the same procedure as that used for **2.7**) gave a good yield (~50%) of a brown oil which was shown by NMR spectroscopy to be the desired substituted indene, **2.8**. It was noted that whilst the substituted cyclopentadiene forms as a mixture of all three possible isomers, the indene forms as the single isomer shown in figure 2.10.1.

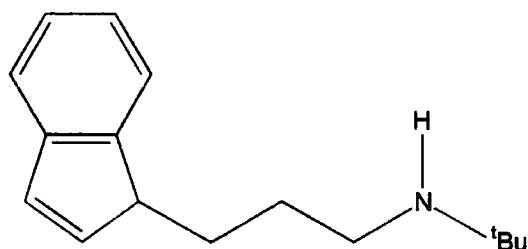

Figure 2.10.1: The substituted indene, 2.8, formed as one isomer only

The amine-substituted indene could not be purified by protonation since indenyl species are highly susceptible to cationic polymerisation.²⁸ Addition of dilute HCl to an ether solution of the indene caused immediate decomposition and formation of an intractable polymer. Analytically pure samples of the amine-substituted indene could only be obtained by careful reduced-pressure distillation. However, the reaction product was found to be sufficiently pure to be used in the synthesis of organometallics without further purification. ^1H and $^{13}\text{C}\{^1\text{H}\}$ NMR spectra of this compound are shown in figures 2.10.2 and 2.10.3 respectively. The spectra show a trace of N-t-butyl azetidine impurity, along with a second, unidentifiable impurity (all impurities marked with an asterisk) which was not removed by distillation.

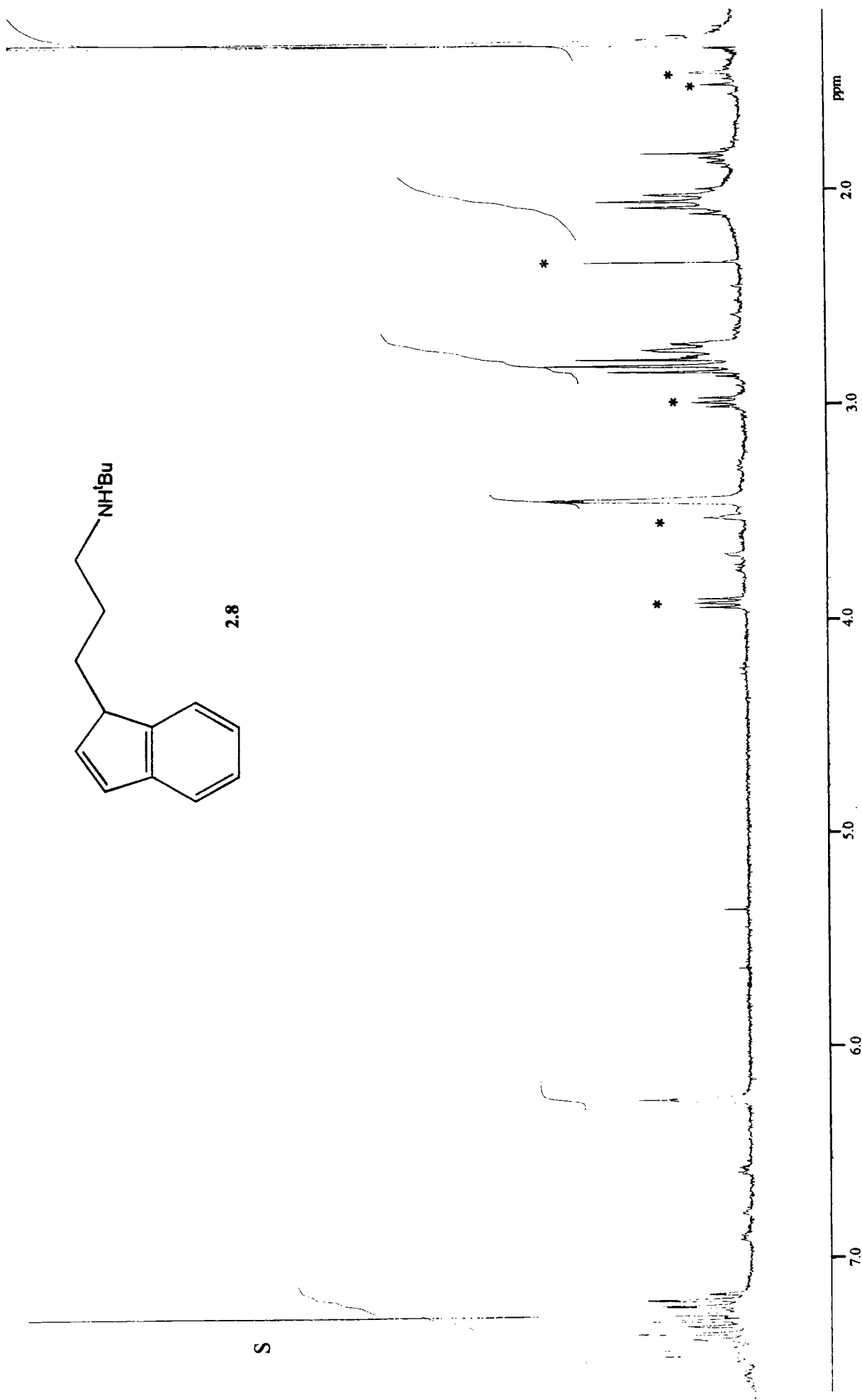

Figure 2.10.2: The ¹H NMR spectrum of 2.8 at 250 MHz in CDCl₃ with solvent marked S and impurities marked *

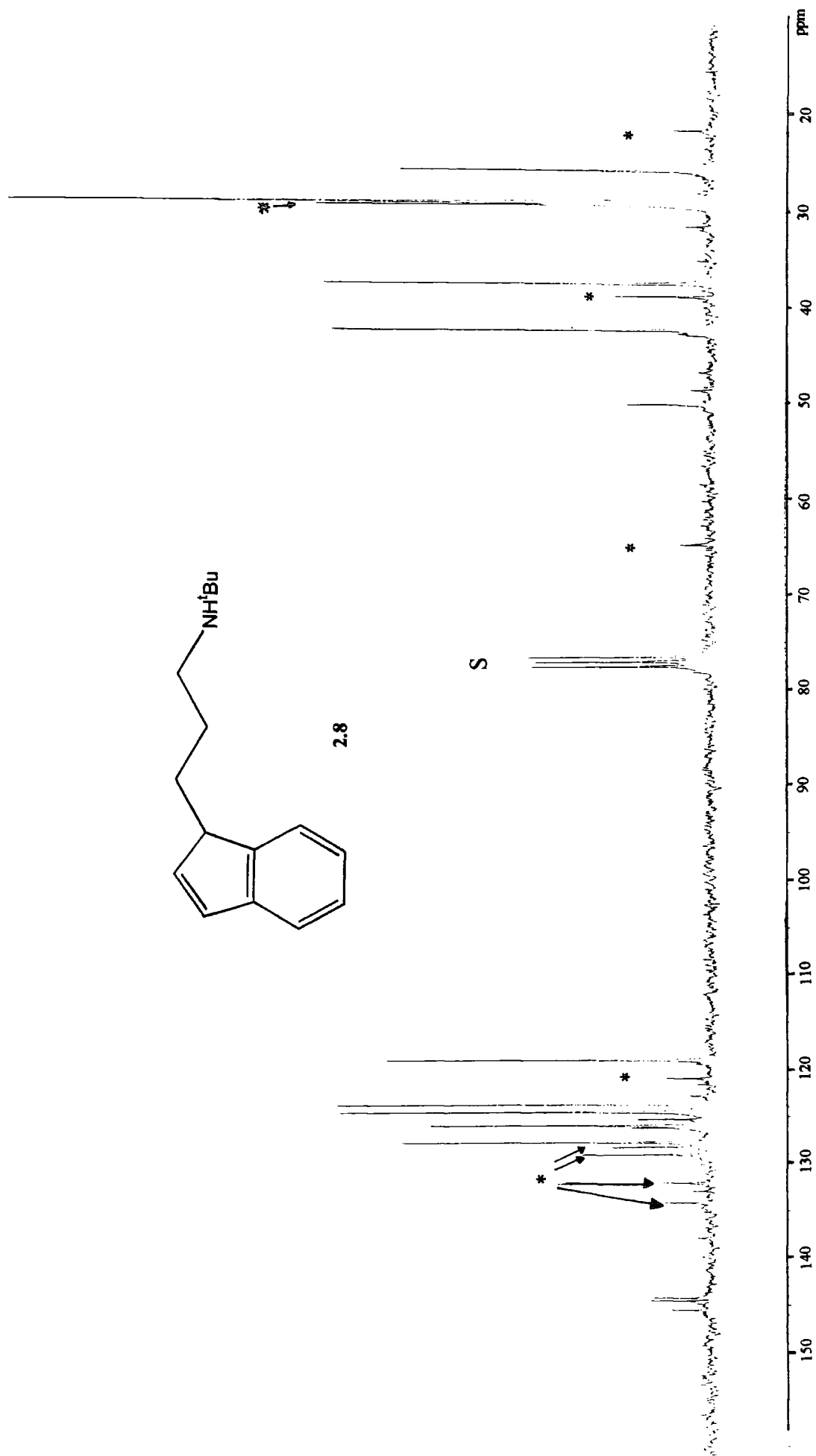

Figure 2.10.3: ¹³C{¹H} NMR spectrum of 2.8 at 62.5MHz in CDCl₃ with solvent marked S and impurities marked *

2.11: Conclusion

The synthetic route chosen has proved to be a simple and relatively high yield route to N-tertiary butylaminopropylcyclopentadiene and N-tertiary butylaminocyclopentadienyl-2-indene. Some problems were encountered, most notably the failure of N-butyl-3-bromopropylamine hydrobromide to react with sodium cyclopentadienide. The use of tertiary butylamine rather than methylamine as a substituent had several beneficial effects as far as the ligand synthesis was concerned, by increasing the yield and eliminating the formation of side-products in the initial step. The crystallinity of the halides **2.3** and **2.4** was increased, making their purification considerably easier and less time consuming. Although the use of tertiary butylamine as the substituent initially led to poor yields of the alcohol **2.2**, this problem was successfully overcome. Once the difficulties were solved it proved possible to synthesise both the cyclopentadienyl and indenyl species in ~25g batches in a relatively short time, the entire synthesis taking roughly a week to complete. The various modifications discussed should make this route readily adaptable for the synthesis of ligands which have different N-substituents, or which have substituents attached to the carbon backbone.

2.12: References for Chapter 2

- 1) e.g. P. Jutzi and J. Dalhaus, *Synthesis*, 1993, 684.
- 2) M. Neuenschwander, "The Chemistry of Functional Groups: Supplement A: The Chemistry of Double-Bonded Functional Groups", Ed. S. Patai, John Wiley & Sons Inc., Chichester, 1989, **Volume 2, Part 2**, p1131.
- 3) (a) P. Jutzi, T. Heidemann, *Synthesis*, 1994, 777; (b) D. M. Bensley and E. A. Mintz, *J. Organomet. Chem.*, 1988, **353**, 91; (c) D. J. Harvan, J. R. Hass, K. L. Buisch, M. M. Bursley, F. Ramirez and S. Meyerson, *J. Am. Chem. Soc.*, 1979, **101**, 7410.
- 4) M. Ogasa, D. T. Mallin, D. W. Macomber, M. D. Rausch, R. D. Rogers and A. D. Rollins, *J. Organomet. Chem.*, 1991, **405**, 41.
- 5) U. Siemeling, O. Vorfeld, B. Neumann and H.-G. Stammer, *Chem. Ber.* 1995, **128**, 481.
- 6) J. W. Coe, M. G. Vetelino and D. S. Kemp, *Tetrahedron Lett.*, 1994, **35**, 6627.
- 7) A. K. Hughes, *Verlagen Werkgroep Organometaalchemie en Homogene Katalyse Rijksuniversiteit Gronigen*, 1992, **1**, 30.
- 8) A. K. Hughes, A. Meetsma and J. H. Teuben, *Organometallics*, 1993, **12**, 1936.
- 9) R. A. Y. Jones, A. R. Katritsky and D. L. Trepanier, *J. Chem. Soc. B.*, 1971, 1300.
- 10) S. R. Koepke, R. Kupper and C. J. Michejda, *J. Org. Chem.*, 1979, **44**, 2718.
- 11) R. Mazingo and J. H. McCracken, *Org. Synth. Coll.* **III**, 1955, 258.
- 12) L. S. Luskin, M. J. Culver, G. E. Gantert, W. E. Craig and R. S. Cook, *J. Am. Chem. Soc.*, 1956, **78**, 4042.
- 13) J. Cooper, Undergraduate Research Project (Nuffield sponsorship), University of Durham, August 1995.
- 14) S. G. Davies and I. A. S. Walters, *J. Chem. Soc. Perkin. Trans.*, 1994, 1129.

- 15) (a) W. M. Rodianov and E. A. Postovskaja, *J. Am. Chem. Soc.*, 1929, **51**, 841; (b) T. B. Johnson and J. E. Livak, *J. Am. Chem. Soc.*, 1936, **58**, 299.
- 16) V. M. Rodianov and E. V. Yavorskaya, *Zh. Obshch. Khim.*, 1953, **23**, 983.
- 17) M. S. Gibson, *Chemistry of the Amino Group*, Interscience Publishers, London, 1968, 63.
- 18) L. Angiolini, A. R. Katritzky and D. M. Read, *Gazz. Chim. Ital.*, 1976, **106**, 111.
- 19) S. Gabriel, *Berichte*, 1917, **50**, 826.
- 20) F. Cortese, *J. Am. Chem. Soc.*, 1936, **58**, 191.
- 21) F. Cortese, *Org. Synth. Coll.*, 1940, **II**, 91.
- 22) S. Gabriel, *Berichte*, 1888, **21**, 566.
- 23) E. J. Masters and M. T. Bogert, *J. Am. Chem. Soc.*, 1942, **64**, 2710.
- 24) A. J. Kingsley and A. K. Hughes, unpublished results.
- 25) S. R. Koepke, R. Kupper and C. J. Michejda, *J. Org. Chem.*, 1979, **44**, 2718.
- 26) A. L. Johnson, Undergraduate Research Project, University of Durham, 1996.
- 27) T.-F. Wang, T.-Y. Lee, J.-W. Chou and C.-W. Ong, *J. Organomet. Chem.*, 1992, **423**, 31.
- 28) P. Sigwalt, *J. Polym. Sci.*, **52**, 1961, 15.

CHAPTER 3

Synthesis of some Main Group and Iron Compounds

3.1: Introduction

Although the main work of this thesis is concerned with group 4 complexes of amine substituted cyclopentadienes and indenenes (described in chapter 4), a variety of other compounds based on such ligands co-ordinated to other metals were investigated. Alkali metal salts, particularly lithium salts, formed by deprotonation of $C_5H_5(CH_2)_3NH^tBu$, **2.7**, and $C_9H_7(CH_2)_3NH^tBu$, **2.8**, were prepared chiefly for use as reagents in the synthesis of transition metal complexes, but some characterisation work was carried out on these alkali metal salts and is presented here. Trialkylsilyl species and Grignard reagents derived from **2.7** and **2.8** were prepared as reactive intermediates, and some examples of these were characterised and are also described in this chapter. Iron(II) complexes of the substituted cyclopentadienyl and indenyl ligands were prepared and fully characterised, along with some of their derivatives, and ferrocene-type complexes were used in the preparation of some heterobimetallic complexes.

3.2: Alkali Metal Compounds

The amine substituted cyclopentadiene and indene, **2.7** and **2.8**, undergo single and double deprotonation reactions (dependant on the stoichiometry of the reaction and the solvent employed) with strong bases such as ^tbutyl lithium or potassium hydride. It was hoped that these alkali metal cyclopentadienides and indenides would prove useful for the preparation of transition metal complexes. In particular, lithium salts of Lewis-base substituted cyclopentadienides have found extensive applications, reported in the literature, for the preparation of other main group complexes,¹ transition metal complexes² and substituted ferrocenes,³ as is more fully discussed in section 1.3.

3.2.1: Reaction between 2.7 and n-butyl lithium in hexanes

Compound 2.7 reacted rapidly and cleanly at room temperature in hexane with one stoichiometric equivalent of ⁿbutyl lithium to give a highly air-sensitive white solid, 3.1, which precipitated out of solution, thus preventing further reaction with any excess of ⁿbutyl lithium which might be present. Characterisation of 3.1 and other similar lithium complexes proved difficult, since as well as being highly oxygen- and moisture-sensitive they were insoluble in most readily available NMR solvents. However, 3.1 was characterised as its THF-adduct 3.1(THF)_n, formed by recrystallisation of the unsolvated species 3.1 from dry, degassed THF. It was discovered that 3.1(THF)_n was soluble in C₆D₆ in the presence of a trace of excess THF. Due to the presence of THF in the NMR sample we were unable to determine the number of co-ordinated THF molecules present (i.e., n in 3.1(THF)_n), but it was possible to deduce other information from the ¹H NMR spectrum thus obtained.

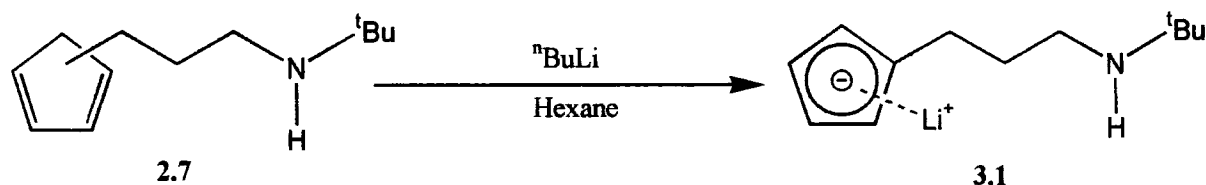

Figure 3.2.1: Mono-deprotonation of 2.7 with n-butyl lithium in hexanes

The ¹H NMR spectrum of 3.1(THF)_n clearly indicates that the parent cyclopentadiene, 2.7, has undergone deprotonation at the ring and not at the amine nitrogen, as shown in figure 3.2.1. This is to be expected, since cyclopentadienes are more acidic than amines (pK_a of C₅H₆ in MeOH = 14-15,⁴ pK_a of RNH₂, R₂NH = ~35⁵). The complex set of peaks present in the aromatic region of the spectrum of the free ligand, 2.7, is found in 3.1(THF)_n to have resolved into a clear AA'BB' spin system, J_{AB} = 1.8Hz. IR

spectroscopy of $3.1(\text{THF})_n$ shows an N-H stretch at 3200 cm^{-1} . Unfortunately it proved impossible, despite repeated attempts, to grow crystals of **3.1** or $3.1(\text{THF})_n$ which were suitable for X-ray diffraction. The DME- and TMEDA-adducts of **3.1** were synthesised in the hope that they might prove more crystalline than the THF-adduct, but this was not the case. However, on the basis of IR and ^1H NMR spectroscopy it is concluded that **2.7** undergoes facile deprotonation at the ring with one equivalent of a strong base. It is possible to conclude with reasonable certainty from the ^1H NMR data that deprotonation occurs first at the ring rather than the amine, and this is in accordance with literature findings about the relative acidities of cyclopentadiene and indene compared to amines. The mono-lithium salt forms cleanly and easily, making it a suitable intermediate for preparing transition metal complexes where the ligand is co-ordinated through the cyclopentadienyl ring only.

3.2.2: Reaction between 2.7 and n butyl lithium in THF

The di-lithium salt derived from double deprotonation of **2.7** was obtained in two ways. A THF solution of the free ligand, **2.7**, reacted cleanly and rapidly with two equivalents of a hexane solution of n butyl lithium at room temperature to give the di-lithium salt, **3.2**,⁹ or a THF solution of the mono-lithium salt **3.1** reacted with one equivalent of a hexane solution of n butyl lithium at room temperature to give **3.2**. These routes are shown in figure 3.2.2. In both cases, the product was isolated by adding further hexane to the THF solution until cloudiness just appeared, then cooling to -30°C to give the product as a fine, white precipitate. Unfortunately, as with **3.1**, it proved impossible to grow crystals of **3.2** or of its THF-, DME- or TMEDA-adducts which were suitable for X-ray diffraction.

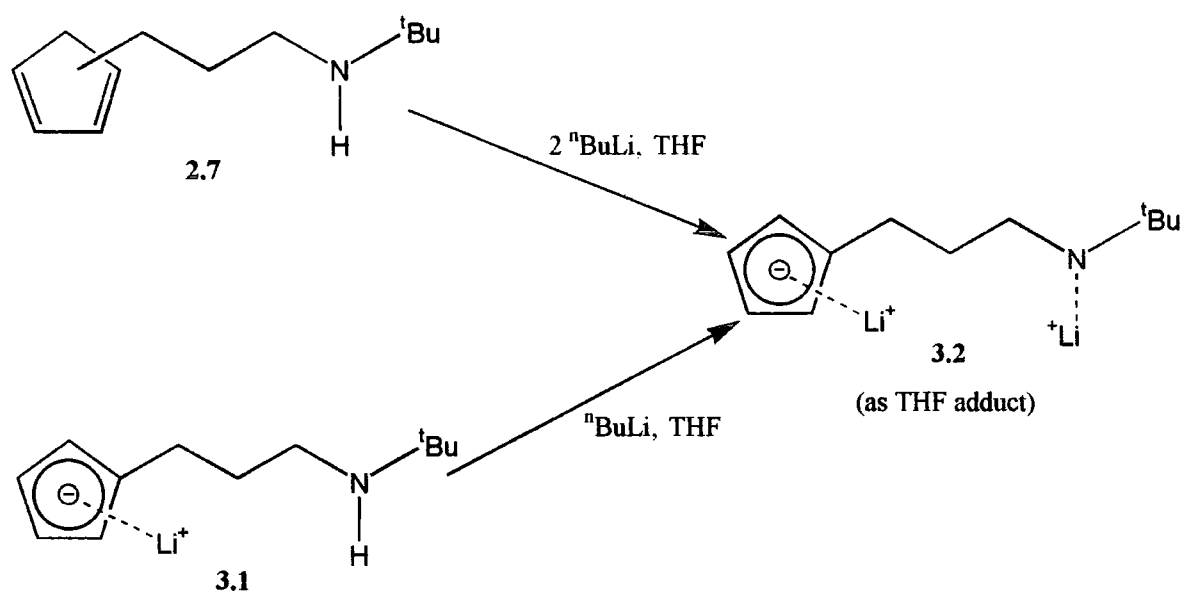

Figure 3.2.2: Synthesis of the di-lithium salt, 3.2

3.2.3: Reaction between 2.8 and n-butyl lithium

Like the substituted cyclopentadiene, 2.7, the substituted indene, 2.8, undergoes single or double deprotonation by a strong base such as n butyl lithium. Depending upon the solvent used for the reaction, 2.8 reacted with one or two equivalents of n butyl lithium to give the mono- and di-lithium salts, 3.3 and 3.4, as highly air- and moisture-sensitive white solids. These compounds were synthesised specifically for use as intermediates in the preparation of other complexes. For this reason, and because they were so highly sensitive and were insoluble in most NMR solvents, no characterisation of these compounds was carried out. We would expect, from the relative acidities of indene and amines (pK_a of indene in methanol = 18.5^1), that deprotonation would occur first at the five-membered ring and then at the amine nitrogen, as shown in figure 3.2.3.

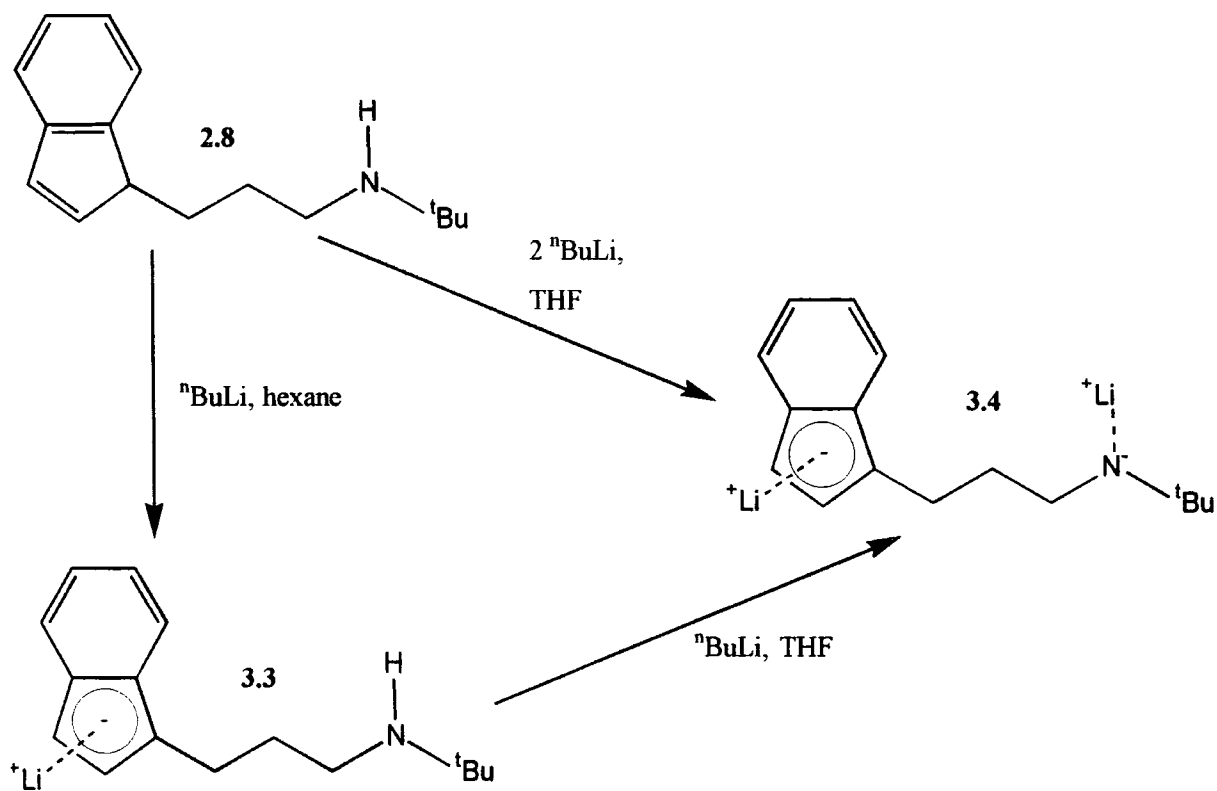

Figure 3.2.3: Synthesis of lithium and di-lithium indenides, 3.3 and 3.4

3.2.3: Other alkali metal salts

The free cyclopentadiene, 2.7, reacted with one equivalent of potassium hydride in THF over several days to give, on work-up, a highly air-sensitive white powder, 3.5. It was hoped that this material might prove to be more crystalline than the lithium salts. However, the highly air-sensitive nature of this compound made handling very difficult, and all attempts at crystal growth led to decomposition of the material. Because of this, no characterisation work was possible for this compound, but it is assumed that deprotonation occurs at the cyclopentadiene ring to give the potassium cyclopentadienide, 3.5, as shown in figure 3.2.4.

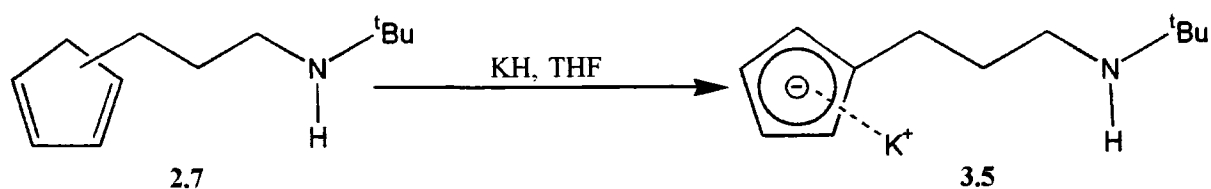

Figure 3.2.4: Synthesis of the potassium cyclopentadienide 3.5

It is also probable that **2.7** would react with one equivalent of sodium metal in a suitable solvent, such as THF to give the mono-sodium salt, although this was not attempted.

3.3: Trialkylsilyl Derivatives of 2.7 and 2.8

The mono- and bis-(trimethylsilyl) cyclopentadienes and indenenes were synthesised by reaction of the mono- and di-lithium salts with trimethylsilyl chloride. It was hoped to use them as precursors to transition metal complexes, particularly of groups 4 and 5, and they were also characterised as compounds in their own right.

3.3.1: Preparation of a mono(trimethylsilyl) derivative of 2.7

The mono-lithium salt **3.1**, prepared as described in section 3.2.1, reacted cleanly and rapidly at room temperature in THF with one equivalent of Me_3SiCl . Although addition of one equivalent of $^n\text{BuLi}$ to a THF solution of the free ligand, **2.7**, followed by addition of Me_3SiCl once reaction had occurred (i.e., without isolating the lithium salt, **3.1**) gave the desired silyl species, **3.6**, it was found that better results in terms of yield and purity of product were obtained if the lithium salt, **3.1**, was isolated and purified before re-dissolving in THF and reacting with Me_3SiCl . Removal of the solvent under reduced pressure followed by extraction of the oily residue with hexane and filtering gave, on removal of the

volatiles from the filtrate, a yellow oil shown by ^1H NMR to be the desired product **3.6** plus some impurities. This reaction is shown in figure 3.3.1.

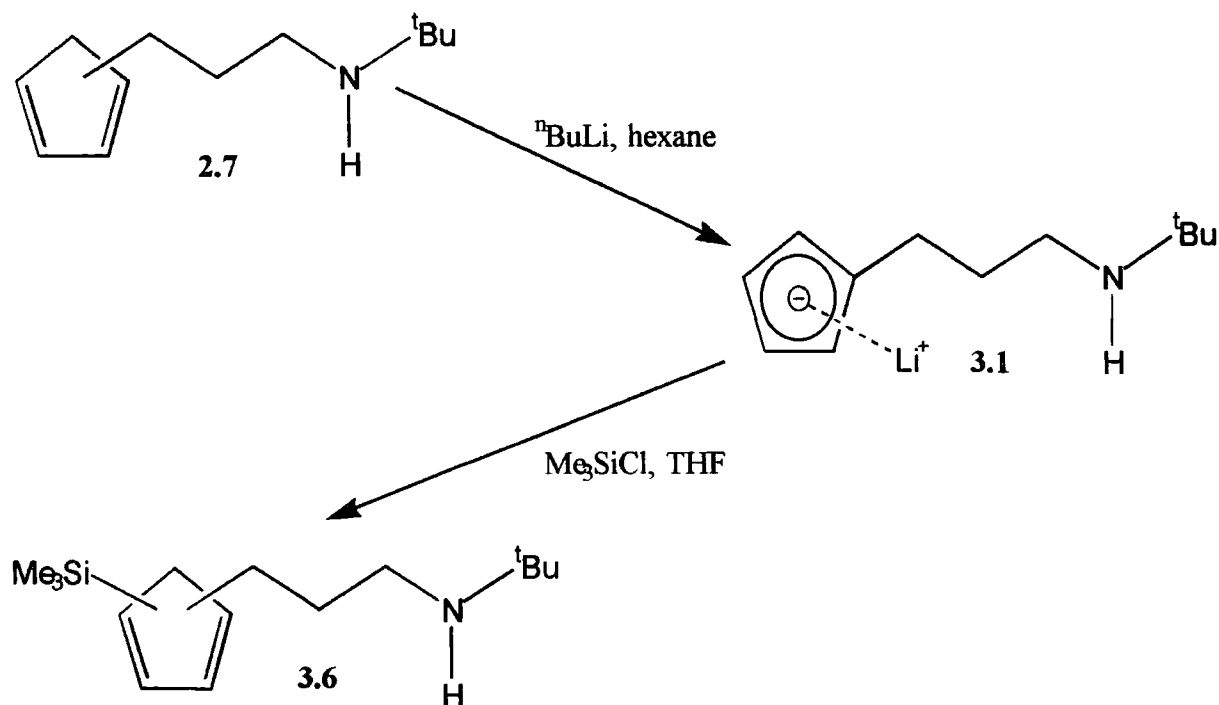

Figure 3.3.1: Synthesis of the trimethylsilyl cyclopentadienyl derivative **3.6**

An analytically pure sample of **3.6** was obtained by careful reduced-pressure distillation of the crude product. The product was found to be air-stable but moisture-sensitive. The ^1H NMR spectrum of this compound is complex, particularly the signals due to ring protons, and it is proposed that the compound forms as a mixture of isomers. It is possible to assign other signals, including those due to the protons in the backbone chain, the t butyl group and the Me_3Si group. The latter shows satellites due to protons coupling to ^{29}Si ($I = 1/2$, relative abundance 4.67%⁶), $^2J_{\text{H-Si}} = 5\text{Hz}$. A signal is also present at 0.96 ppm which is assigned to the N-H proton. The $^{13}\text{C}\{^1\text{H}\}$ NMR spectrum is also complex, but once again it is possible to assign the backbone, t butyl and Me_3Si signals. Since the

NMR sample was fairly dilute it is not possible to distinguish ^{29}Si satellites from noise in the baseline. The IR spectrum shows a weak signal due to N-H stretches at 3400cm^{-1} .

3.3.2: Preparation of a bis(trimethylsilyl) derivative of 2.7

The bis(silyl) compound, **3.7**, was made in a similar manner to the mono(silyl), by reaction between a THF solution of the di-lithium salt, **3.2**, prepared as described in 3.2.2, and Me_3SiCl . Again, it was found that while the di-lithium salt could be prepared as a THF solution and used directly for reaction with Me_3SiCl , better results were obtained in terms of yield and purity of the product, **3.7**, if the di-lithium salt, **3.2**, was first isolated and purified. Like the mono(silyl) compound, **3.6**, the bis(silyl), **3.7**, was a yellow oil, purifiable by reduced pressure distillation, which was air stable but moisture sensitive. The reaction is shown in figure 3.3.2.

The NMR spectra of **3.7** are complex. The ^1H NMR spectrum is similar to that of **3.6** except that the signal proposed to be due to the N-H proton has disappeared, and the spectrum now contains two distinct SiMe_3 signals, both displaying ^{29}Si satellites. The $^{13}\text{C}\{^1\text{H}\}$ NMR spectrum also shows two SiMe_3 signals, and due to the sample being much more concentrated, it is possible to see ^{29}Si satellites (for chemical shift values and coupling constants see section 6.3.4). This compound was stable in CDCl_3 over periods of several hours or even days, but when a sample which was several weeks old was examined by NMR it was discovered that the spectra had altered considerably, and it is concluded that this compound reacts with CDCl_3 or HCl over a period of time to give a complex and unidentifiable mixture of products.

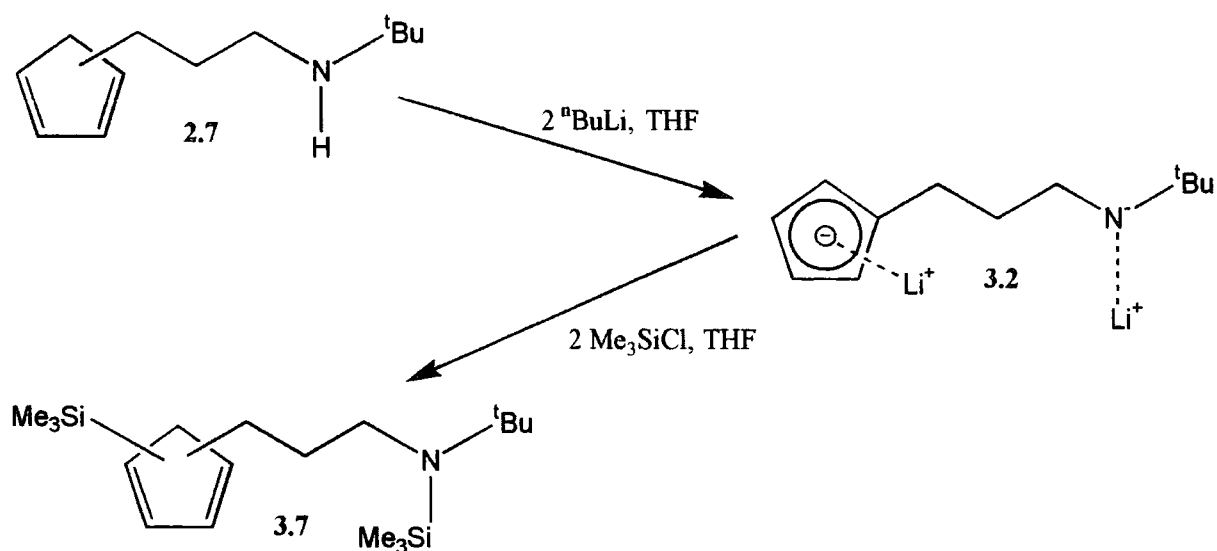

Figure 3.3.2: Preparation of the bis (trimethylsilyl) cyclopentadienyl 3.7

3.3.3) Trialkylsilyl derivatives of 2.8

Mono- and bis(silyl) derivatives, 3.8 and 3.9, of the substituted indene, 2.8, were synthesised in an identical manner to those of the cyclopentadiene, 2.7, by reaction of the mono- and di-lithium indenides, 3.3 and 3.4, with one or two equivalents of Me_3SiCl . However, these were only prepared for use as intermediates in the preparation of other compounds and were not characterised in their own right. A scheme for their synthesis is shown in figure 3.3.3.

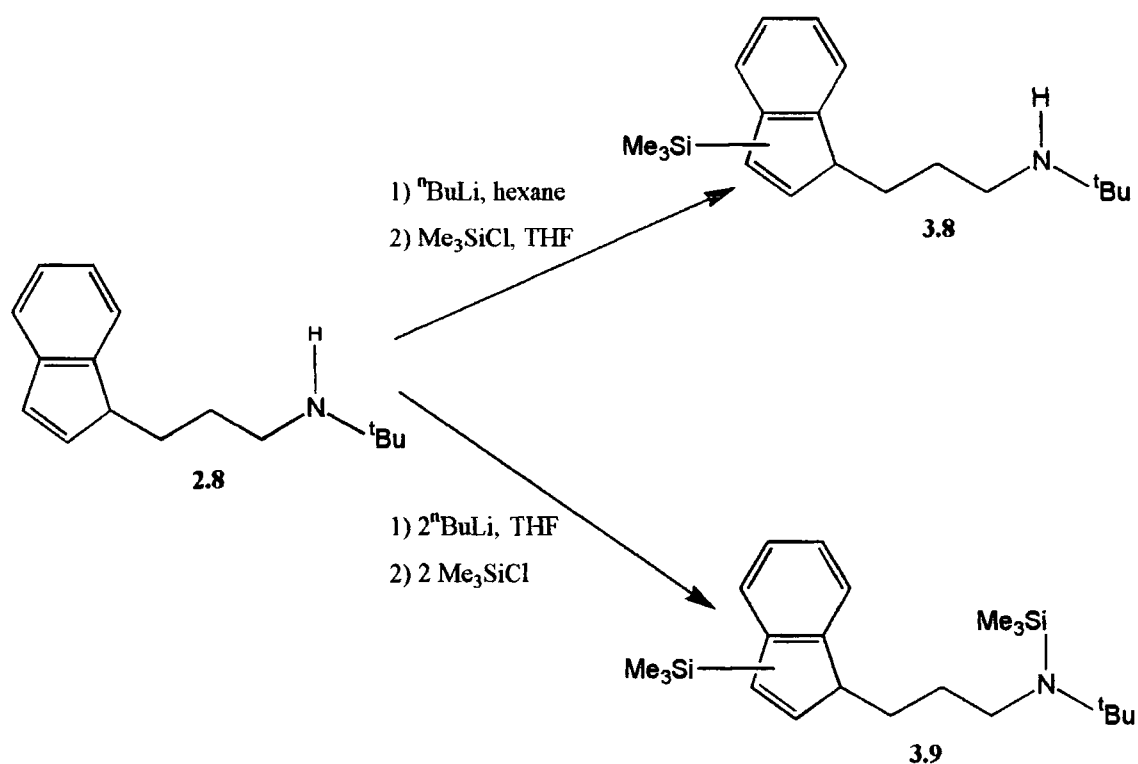

Figure 3.3.3: Synthesis of trimethylsilyl derivatives of 2.8

3.4: Synthesis of Other Main Group Compounds

3.4.1: Preparation of Grignard derivatives of 2.7

As expected, the cyclopentadienyl ligand, 2.7, reacted with either one or two equivalents of an alkyl Grignard reagent, usually MeMgBr , as shown in figure 3.3.4 to give air-sensitive white solids, 3.10 and 3.11, which were highly insoluble in most readily available NMR solvents. For this reason, characterisation of these compounds was essentially limited to IR spectroscopy. Their insolubility in many solvents also made them of limited use for further chemistry. It is known from the literature that Grignard reagents prepared from secondary amine-substituted cyclopentadienes contain intramolecularly coordinated nitrogen (see chapter 1.3 for discussion and diagram).⁷ Due to lack of

characterising data it is impossible to deduce whether or not the Grignard reagents of the primary-amine substituted cyclopentadiene contain intramolecularly co-ordinated nitrogen.

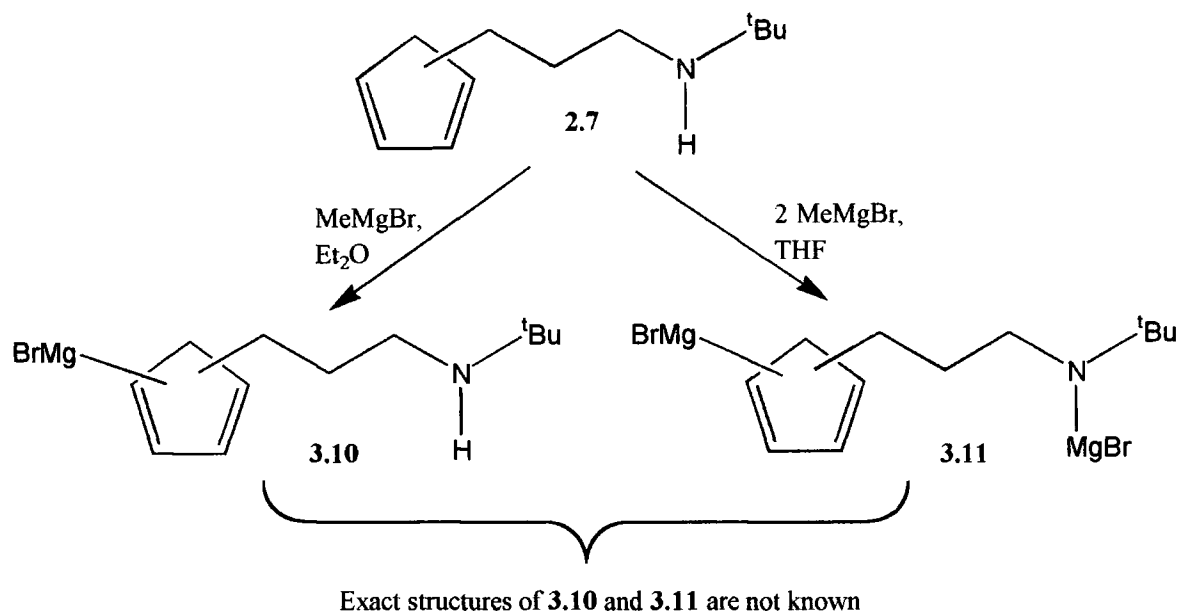

Figure 3.3.4: Grignard reagents derived from 2.7

3.4.2: Reaction between 2.7 and dimethyl zinc

It was hoped that **2.7** would react with one equivalent of Me_2Zn to give a zinc (II) species $\{\eta^5: \eta^1\text{-C}_5\text{H}_4(\text{CH}_2)_3\text{N}^t\text{Bu}\}\text{Zn}$ in which the ligand was co-ordinated through both the cyclopentadienyl ring and the amine nitrogen. Reaction did indeed take place to give on work-up a pale yellow oil. However, even after distillation of this oil, its NMR spectra were extremely complex, and it was concluded that a mixture of products was formed by this reaction.

3.5) Amine-substituted ferrocenes

Many examples exist in the literature of Lewis-base substituted ferrocenes, some of which are discussed in section 1.4. These complexes are particularly interesting since they can potentially be used as redox-active ligands for other transition-metal ions.⁸

3.5.1: Synthesis of a substituted ferrocene from 2.7

An iron complex, bis(tertiarybutylaminopropyl cyclopentadienyl) iron (II), **3.12**, was prepared using a modification of one literature synthesis of $(C_5H_5)_2Fe$,⁹ which is known to be readily adaptable to the synthesis of Lewis-base substituted ferrocenes. Anhydrous $FeCl_2$ was added to a freshly prepared THF solution containing two equivalents of the mono-lithiated ligand **3.1**. The dark coloured reaction mixture was stirred overnight before the volatiles were removed and the residue extracted with petrol and diethyl ether to give a bright orange oil, **3.12**, shown by 1H NMR to be the desired ferrocene. This reaction is shown in figure 3.5.1.

The substituted ferrocene, **3.12**, was purified by careful reduced pressure distillation, since even when pure, this compound is an oil at room temperature. It was not possible to obtain crystals for X-ray diffraction since **3.12** remains liquid even down to low temperatures ($-78^\circ C$). However, the product was characterised comprehensively by other methods. Yields for this reaction are low, seldom exceeding 40%. A number of modifications were tried in order to improve the yield, including isolating and purifying the lithiated cyclopentadiene before adding the $FeCl_2$, changing the solvent, temperature and reaction time, and using a more soluble iron (II) compound such as $FeCl_2(Py)_4$ as a starting material. None of these modifications had any noticeable effect on the yield.

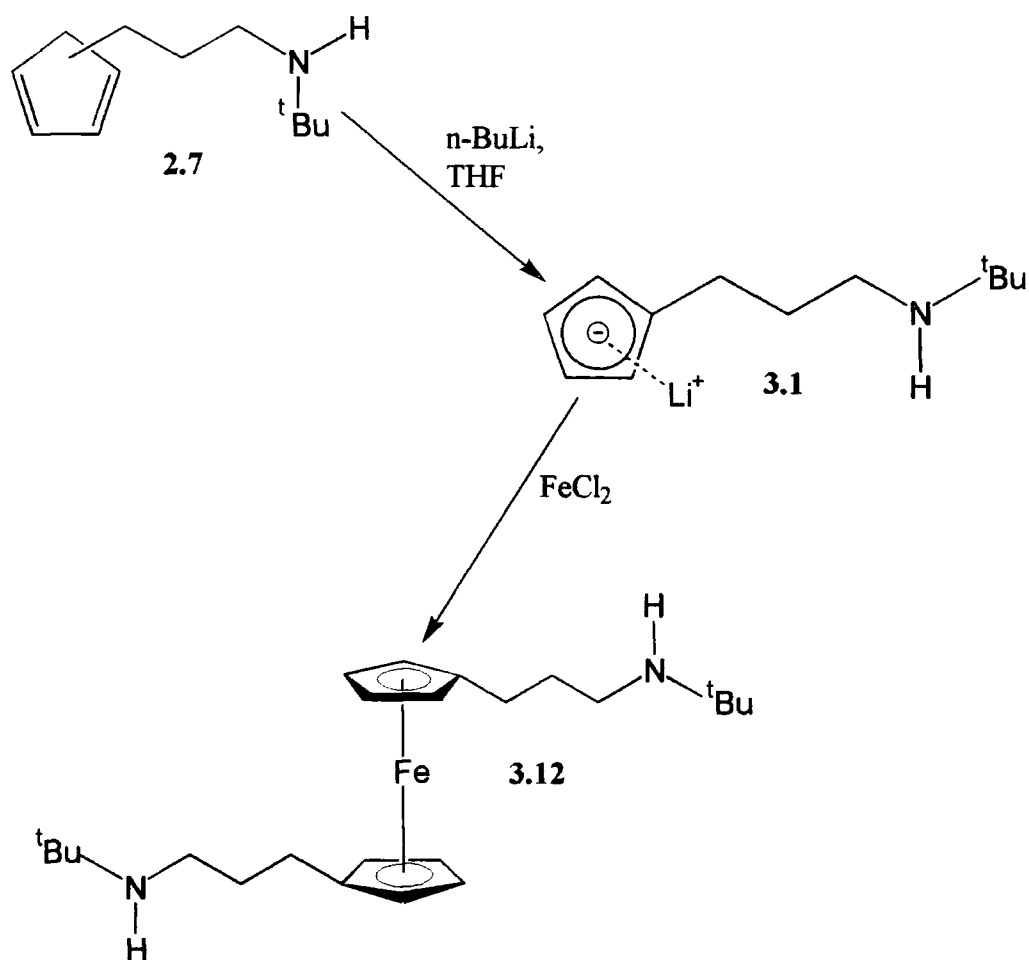

Figure 3.5.1: Synthesis of the amine-substituted ferrocene 3.12

The ^1H NMR spectrum of 3.12, shown in figure 3.5.2, proved misleading at first, since the cyclopentadienyl ring appears a singlet and we would expect an AA'BB' system. However, the product was obviously not free ligand, 2.7, since 2.7 gives complex multiplets in this region of the ^1H spectrum. The $^{13}\text{C}\{^1\text{H}\}$ NMR spectrum (figure 3.5.3) gave three signals for the cyclopentadiene ring as expected: one weak resonance at a high frequency for the *ipso* carbon, and two resonances for the other ring carbons. The chemical shift values for the ring protons and carbons were both comparable to those of ferrocene (C_5H_5) $_2\text{Fe}$ ($\delta^1\text{H}$, 250MHz, $\text{CDCl}_3 = 4.28$, $\delta^{13}\text{C} = 67.9$ ppm¹⁰).

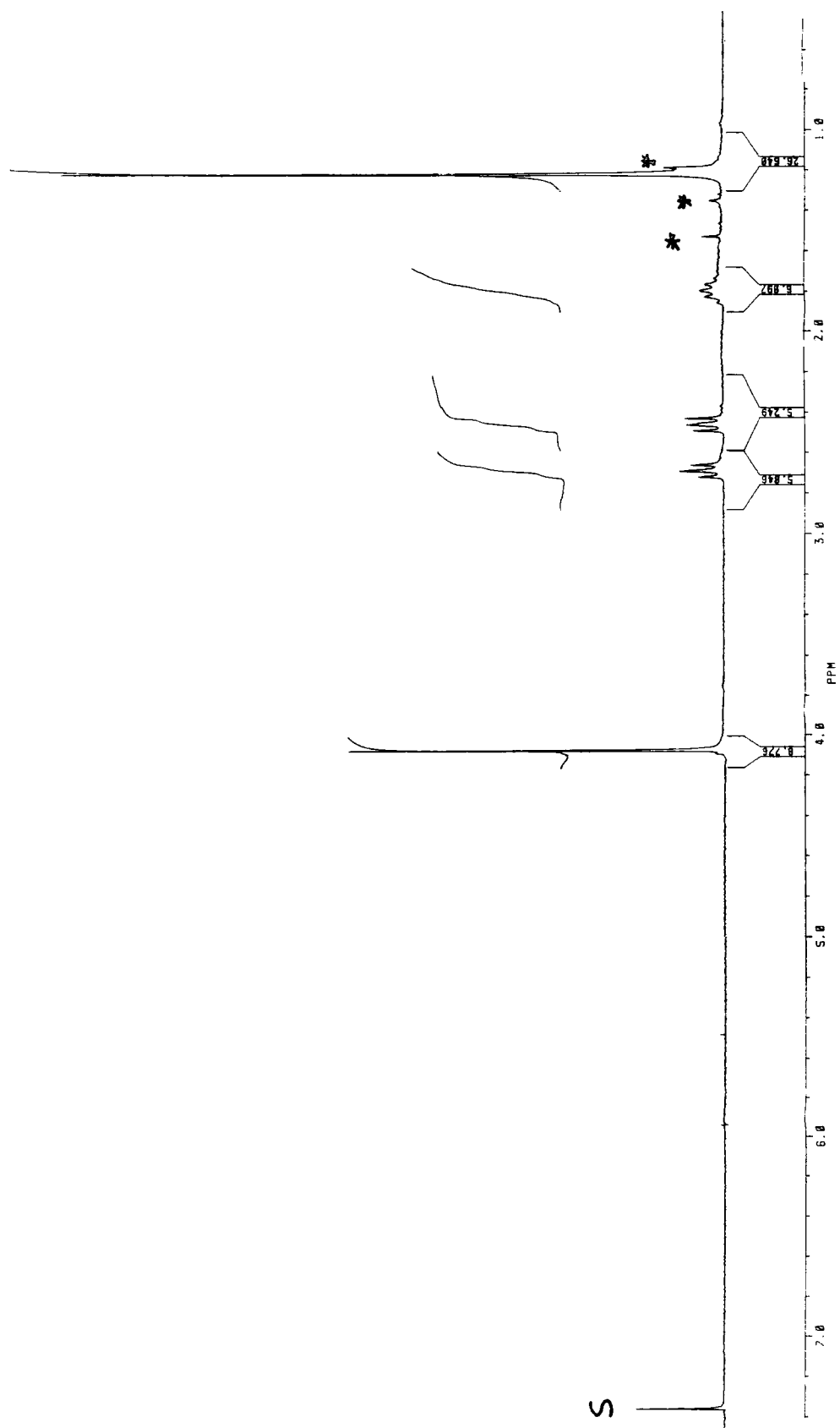

Figure 3.5.2: ^1H NMR spectrum of 3.12 at 250MHz in CDCl_3 with solvent marked S and impurities marked *

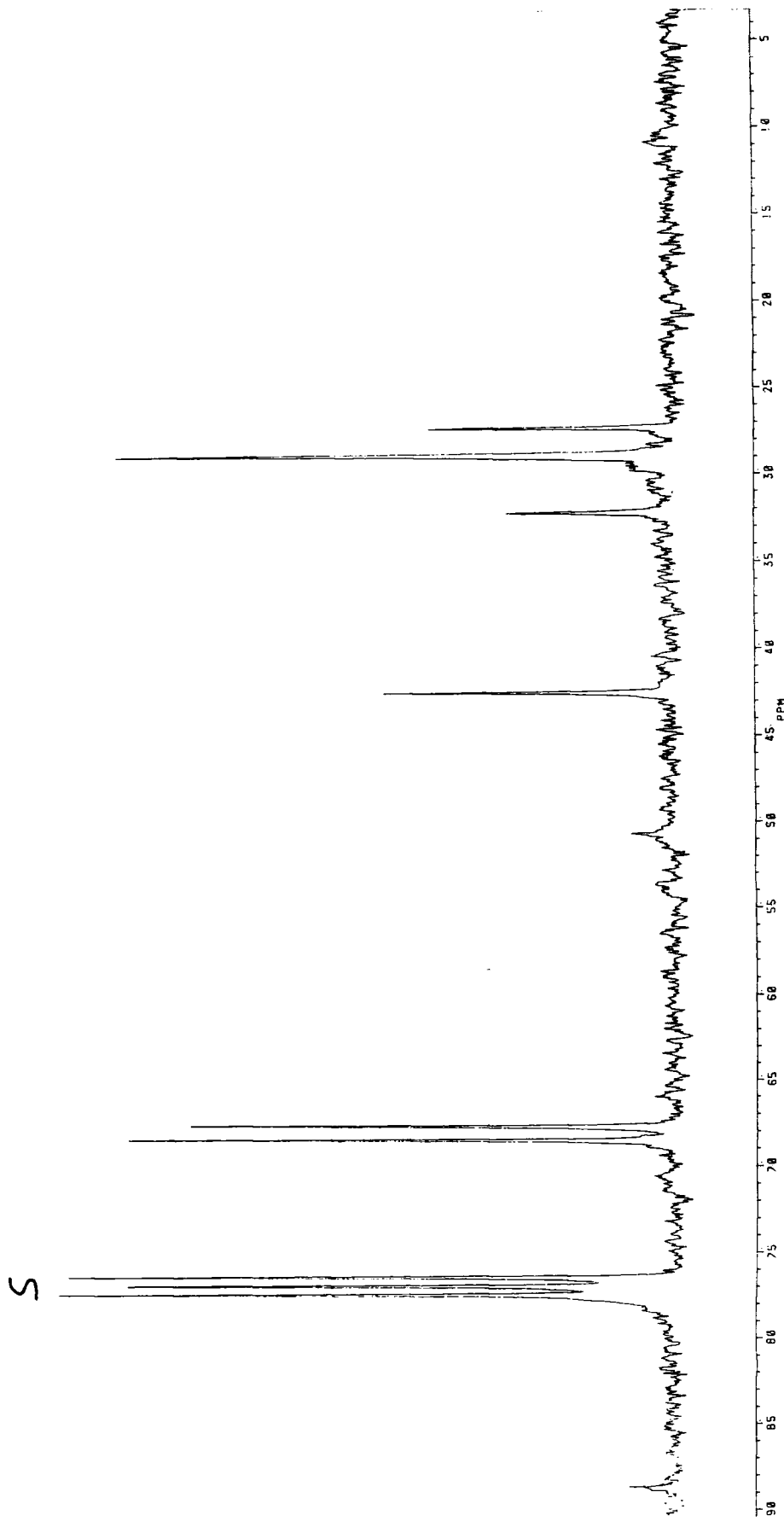

Figure 3.5.3: $^{13}\text{C}\{^1\text{H}\}$ NMR spectrum of 3.12 at 62.5MHz in CDCl_3 (marked S)

The IR spectrum of **3.12** (shown in figure 3.5.4) shows a strong, broad band at 3310 cm^{-1} attributable to N-H stretches. It also shows strong bands assignable to aliphatic and aromatic C-H stretches, and to C-H bends of a co-ordinated cyclopentadienyl ring. The electron ionisation mass spectrum clearly shows the molecular ion, mass 412. A second strong peak at mass 234 corresponds to loss of one $(\text{C}_5\text{H}_4)(\text{CH}_2)_3\text{NHC}(\text{CH}_3)_3$ fragment.

3.5.2: Oxidation of **3.12**

As expected, the amine substituted ferrocene, **3.12**, was oxidised fairly easily to give the ferricenium ion $[\text{Fe}(\text{C}_5\text{H}_4(\text{CH}_2)_3\text{NH}^t\text{Bu})_2]^+$, **[3.13]⁺**, which was isolated as its PF_6^- salt, **[3.13]⁺PF₆⁻**. The oxidation was carried out as shown in figure 3.5.5, by addition of two equivalents of an aqueous solution of FeCl_3 to a THF solution of **3.12**. Reaction occurred immediately, giving a dark blue solution of the substituted ferricenium ion, **[3.13]⁺**, as its FeCl_4^- salt, **[3.13]⁺[FeCl₄]⁻**. Addition of one equivalent of NH_4PF_6 to this solution caused precipitation of the ferricenium ion as its hexafluorophosphate salt, **[3.13]⁺[PF₆]⁻**. The ferrocenium ion, **[3.13]⁺**, could be easily reduced back to the ferrocene, **3.13**, using magnesium as a reducing agent.

Since the substituted ferricenium ion is paramagnetic, characterisation by NMR spectroscopy was not possible and the product could only be characterised by elemental analysis, IR spectroscopy and magnetic susceptibility measurements. The IR spectrum of **[3.13]⁺PF₆⁻**, which is shown in figure 3.5.4 along with that of **3.12**, showed a strong N-H stretch, in addition to bands characteristic of the C-H bends of a co-ordinated cyclopentadienyl ring, and a strong band at 836cm^{-1} which is characteristic of the PF_6^- anion. Solid state magnetic susceptibility measurements, carried out at room temperature as described in appendix A, gave an effective magnetic moment for the hexafluorophosphate salt

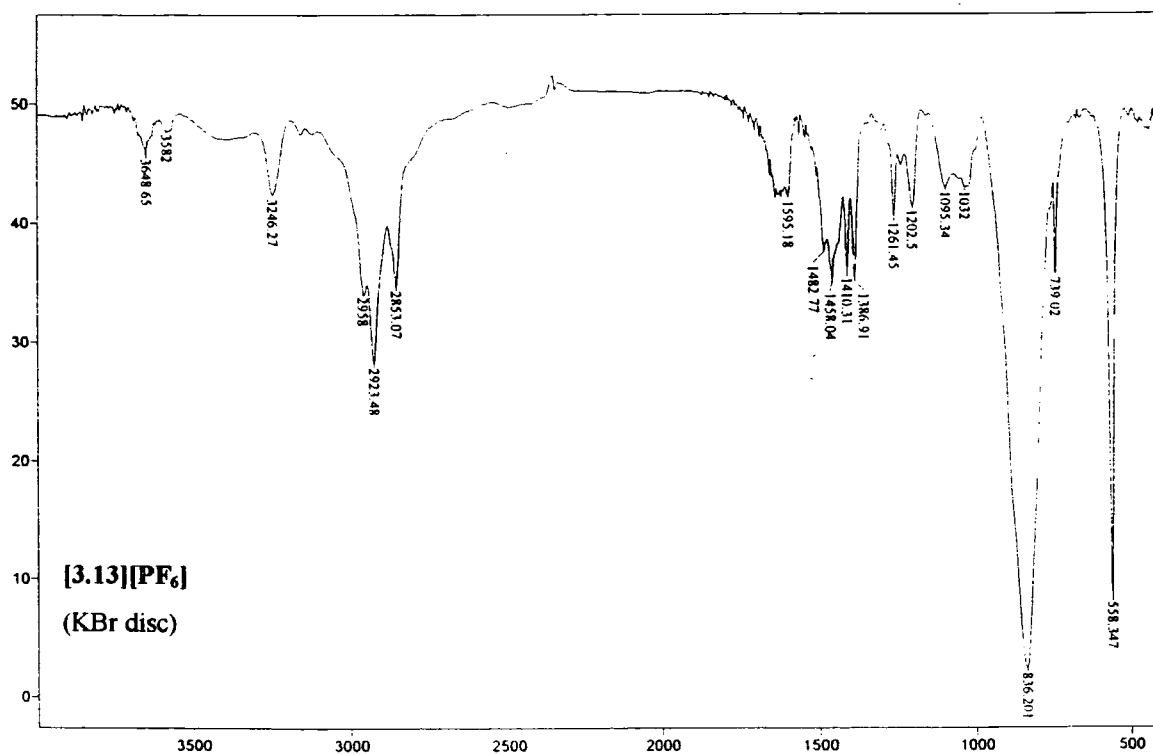
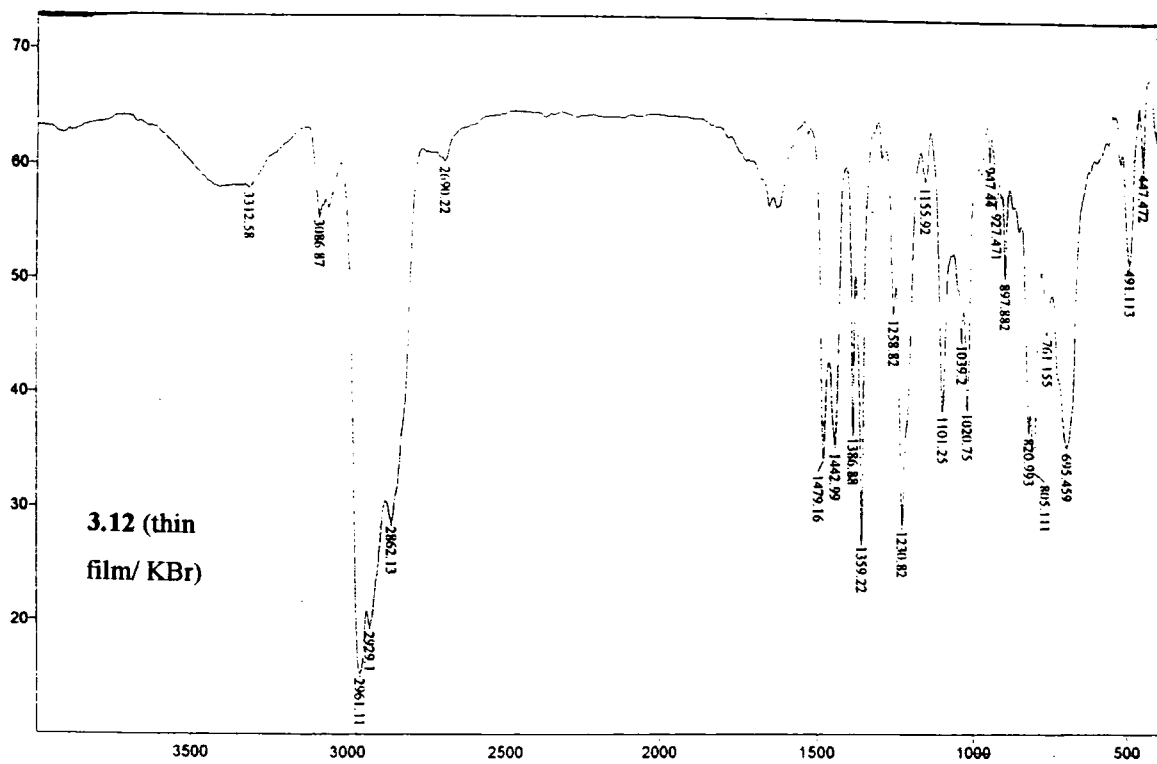

Figure 3.5.4: Infra-red spectra of 3.12 (top) and [3.13]⁺PF₆⁻ (bottom)

$[3.13]^+PF_6^-$, of $5.67\mu_B$, which is rather high for a ferricenium ion (the literature gives a value of $\mu_{\text{eff}} \approx 2.6\mu_B$ for $[Fe(C_5H_5)_2][PF_6]^{11}$). This high value is probably due to traces of the $FeCl_4^-$ salt present in the sample, since the $FeCl_4^-$ anion is itself paramagnetic as it contains a tetrahedral, high spin iron(III) centre. To demonstrate this, the effective magnetic moment of $[(C_5H_5)_2Fe]^+[PF_6]^-$, which had been prepared using a similar method (i.e., *via* the $FeCl_4^-$ salt) was measured and was found to be higher than expected by a similar amount.¹²

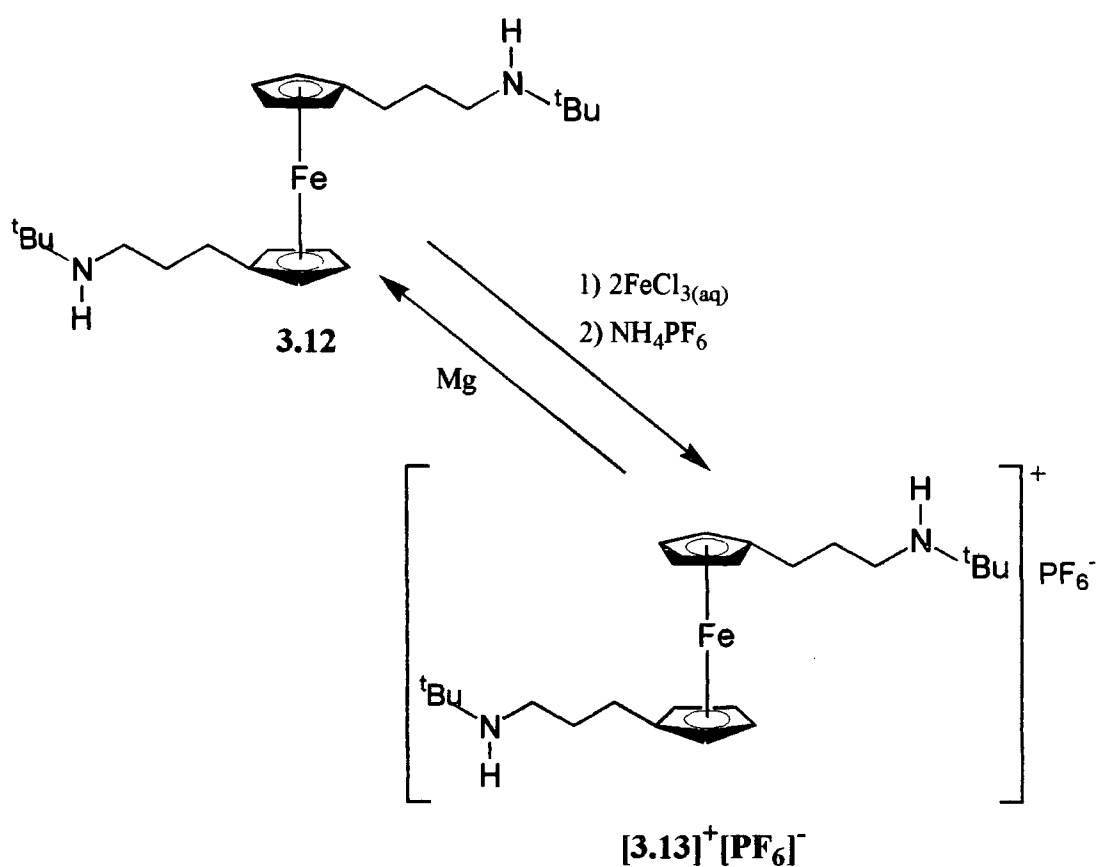

Figure 3.5.5: Oxidation of 3.12 to $[3.13]^+$

3.5.3: Preparation of an iron(II) complex of the substituted indene 2.8

The bis(indenyl) iron (II) compound ($C_9H_6(CH_2)_3NH^tBu$)₂Fe, **3.14**, was prepared in a similar manner to the ferrocene, **3.12**, as shown in figure 3.5.6.

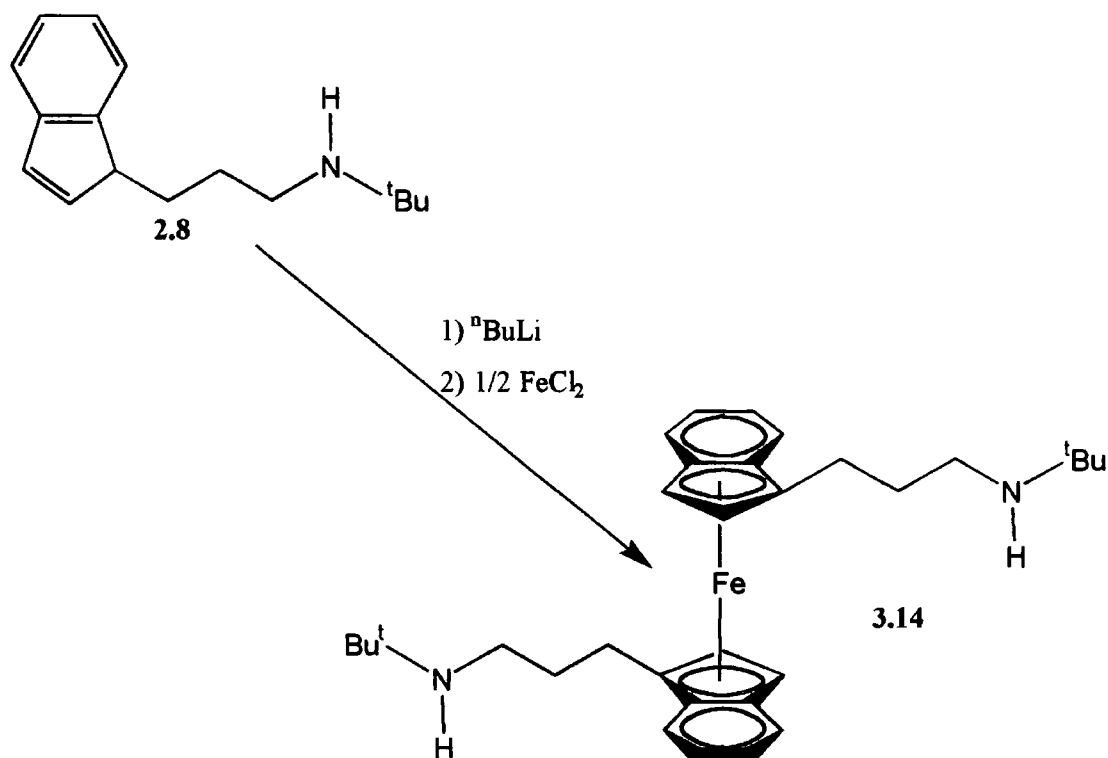

Figure 3.5.6: Synthesis of a bis(indenyl) iron(II) complex, **3.14**

Addition of FeCl₂ to a freshly prepared THF solution of the substituted mono-lithium indenide, **3.3**, gave, on work-up, a dark purple oil, **3.14**, which was purified by reduced-pressure distillation and characterised by IR and ¹H and ¹³C{¹H} NMR spectroscopy. It proved impossible to obtain well-resolved ¹H NMR spectra, possibly due to paramagnetic impurities present in the sample. Bis(indenyl) iron(II) complexes are known to be more easily oxidised than bis(cyclopentadienyl) iron (II),¹³ therefore it is possible that paramagnetic iron(III) impurities arising from reaction with oxygen or moisture were contaminating the compound. ¹³C{¹H} NMR spectroscopy proved more useful. The ¹³C{¹H} NMR

spectrum, shown in figure 3.5.7, showed resonances consistent with the expected compound except that only one C-H resonance was detected for the five membered ring, $\delta = 118.8\text{ppm}$. It is not known why this was the case, since the ^1H spectrum gave, as expected, two signals for the five-membered ring ($\delta = 4.50\text{ppm}$ and $\delta = 4.41\text{ppm}$), although these were broad. The $^{13}\text{C}\{^1\text{H}\}$ spectrum also showed an extra signal, $\delta = 29.1\text{ppm}$, which the coupled ^{13}C NMR spectrum (shown in figure 3.5.8), and the DEPT spectra (shown in figure 3.5.9) showed to be due to a CH_2 group. Some weak signals were also observed in the aromatic region of the spectrum due to CH and quaternary carbons which were not assignable to the expected product. Comparison with the ^{13}C NMR spectrum of the free ligand (shown in figure 2.10.3) shows that these signals correspond to the same trace impurity present in the free ligand **2.8**, and which survives distillation of both **2.8** and the bis(indenyl)iron, **3.14**. It has not been possible to identify this impurity conclusively, though it was confirmed that it is not indene by comparison with the NMR spectra of indene ($\delta^{13}\text{C}$, 62.5MHz, $\text{CDCl}_3 = 144.8, 143.7, 134.2, 132.1, 126.2, 124.5, 123.7, 121.0, 39.9$).¹⁴

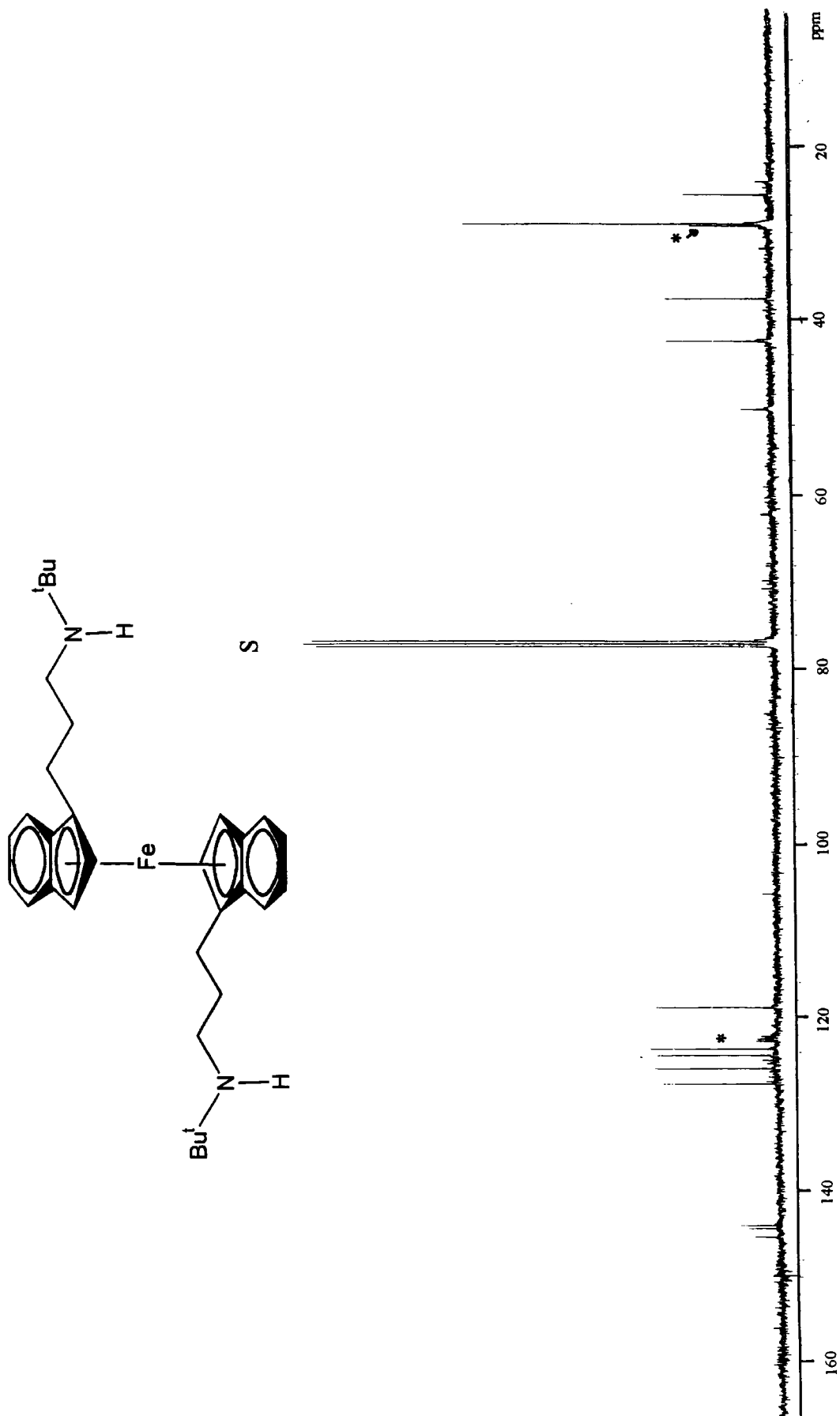

Figure 3.5.7: The $^{13}\text{C}\{^1\text{H}\}$ NMR spectrum of 3.14 at 62.5 MHz in CDCl_3 (marked S), impurities marked *

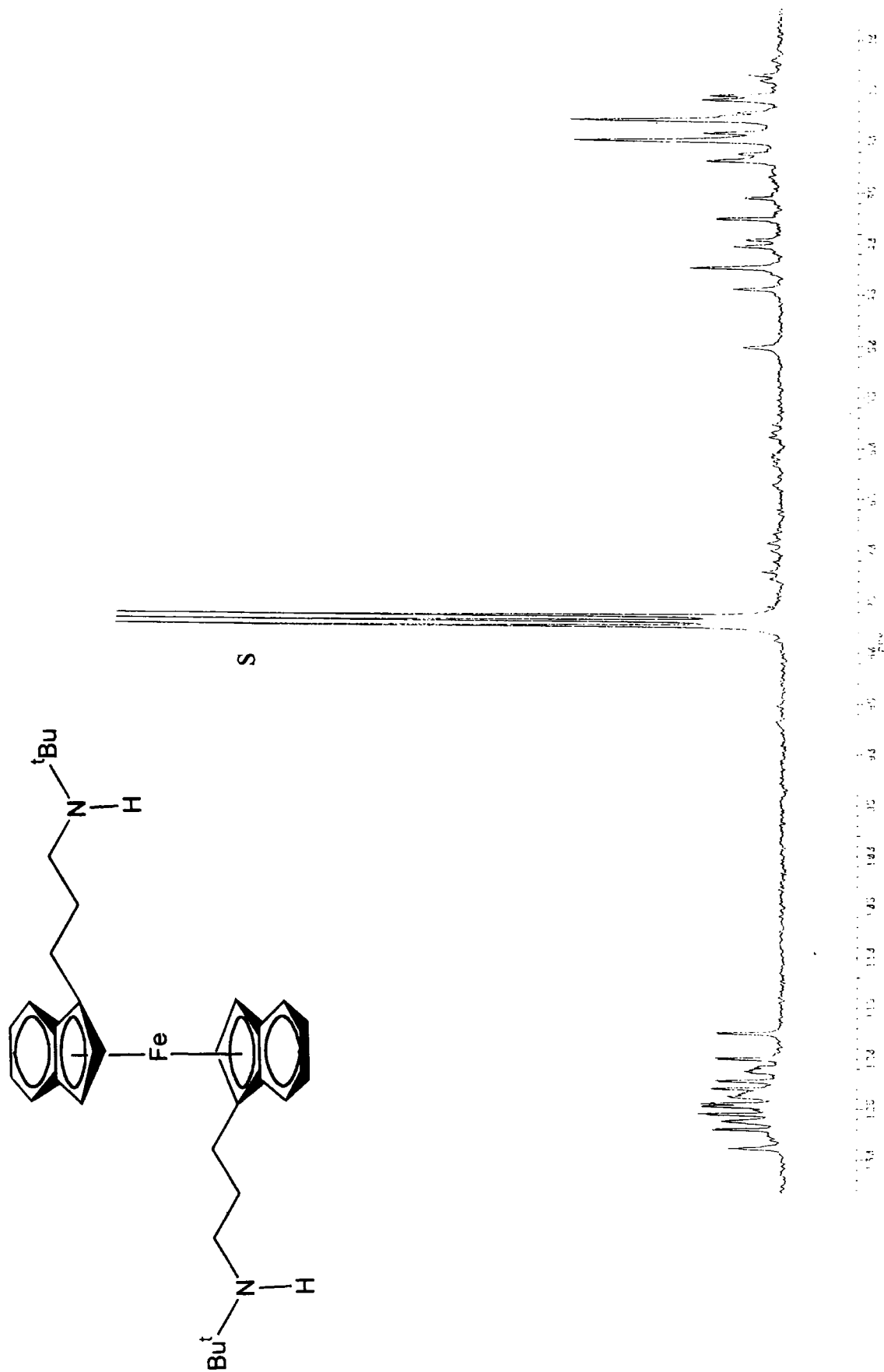

Figure 3.5.8: Coupled ^{13}C NMR spectrum of 3.14 at 62.5 MHz in CDCl_3 (marked S)

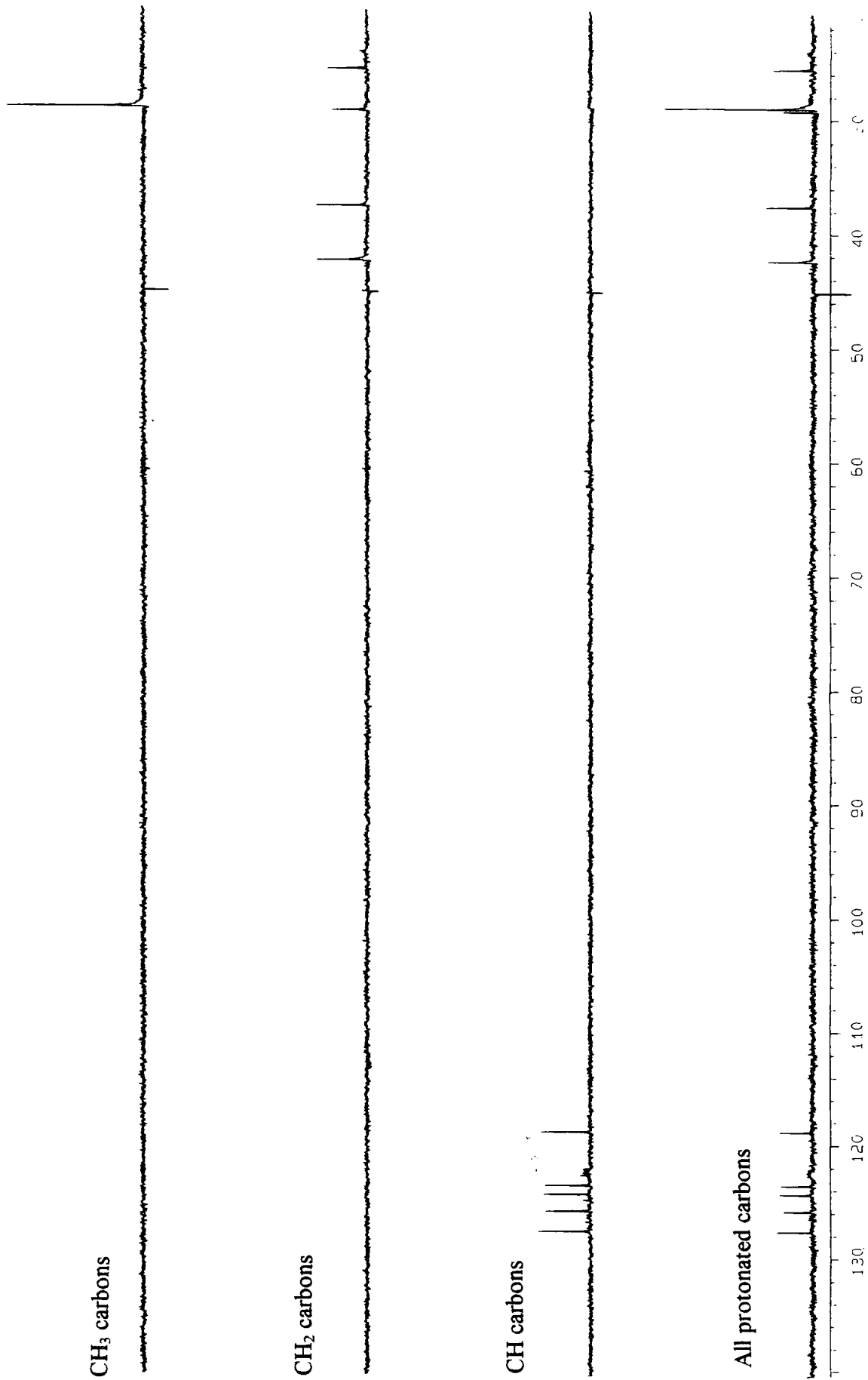

Figure 3.5.9: DEPT spectra of 3.14 at 100 MHz in CDCl₃

3.6: Preparation of Heterobimetallic Compounds

3.6.1) Background

Lewis-base substituted ferrocenes have attracted a great deal of attention as possible building blocks for oligometallic and heterobimetallic complexes, since the Lewis-base functionality (which is not co-ordinated intramolecularly to the metal centre) is available for co-ordination to a second metal.^{3a} Other Lewis-base substituted metal cyclopentadienyl complexes with uncoordinated Lewis-base functionalities have also been used.¹⁵ The phosphine substituted cyclopentadienyl ligand $C_5H_5PPh_2$ has been widely used in the synthesis of heterobimetallic complexes since the phosphine group is attached directly to the ring and is sterically unable to co-ordinate intramolecularly to a metal.¹⁶ Many complexes of this ligand have been synthesised and used in the preparation of a variety of heterobimetallic species including Fe-Pt,¹⁷ Mo-Re,¹⁸ Zr-Fe or Zr-Co^{19, 20} and Ti-Mn.²¹ Some examples are shown in figure 3.6.1.

Other phosphine-substituted cyclopentadiene ligands with spacer units between the ring and the phosphine group have been used in the preparation of heterobimetallic species.¹⁶ The ferrocene derivative of the $C_5H_5SiMe_2CH_2PPh_2$ ligand has been used to prepare Fe-Ni complexes,²² and a zirconocene analogue of the same ligand has been used to prepare Fe-Zr complexes as shown in figure 3.6.2.²²

The phosphine-functionalised ligand $C_5H_5(CH_2)_2PPh_2$ has been used to prepare heterobimetallics based on the group 4 metallocene dichlorides $(C_5H_4(CH_2)_2PPh_2)_2MCl_2$ (M = Ti, Zr) with molybdenum as the second metal as shown in figure 3.6.3.²³



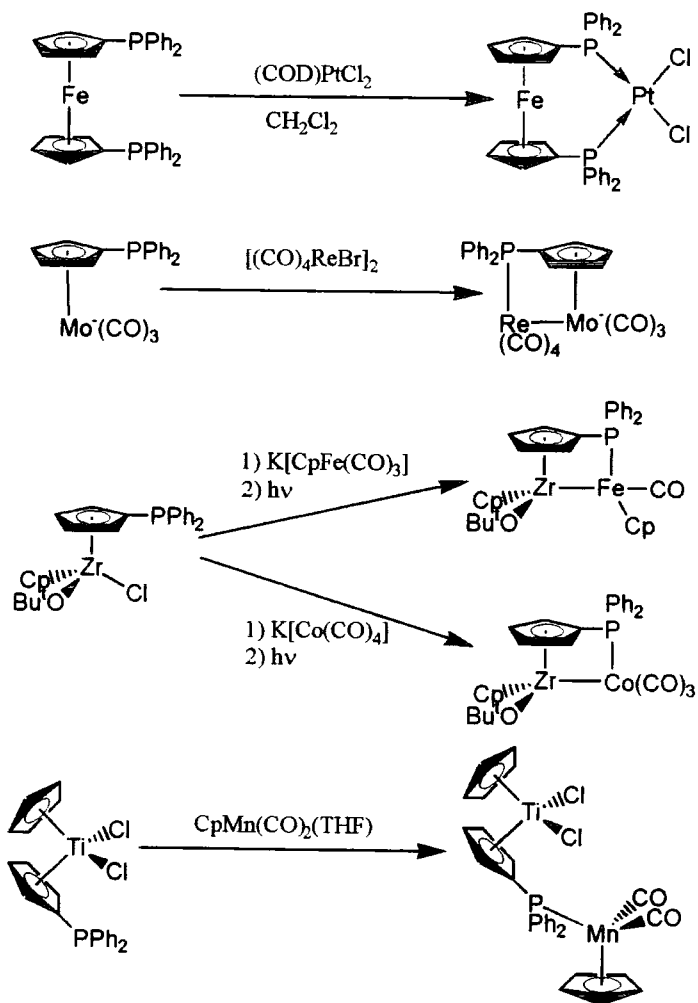

Figure 3.6.1: Heterobimetallic complexes based on the $C_5H_5PPh_2$ ligand

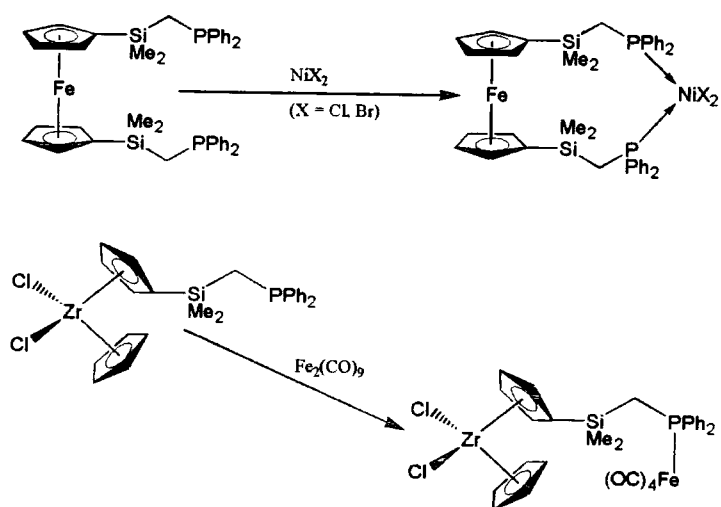

Figure 3.6.2: Heterobimetallics based on the $C_5H_5SiMe_2CH_2PPh_2$ ligand

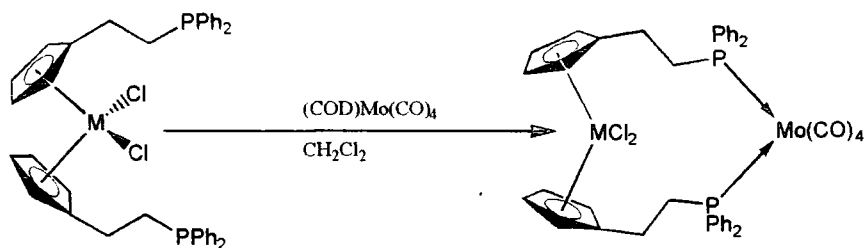

Figure 3.6.3: Heterobimetallic complex of group 4 metallocene dichlorides of $\text{C}_5\text{H}_5(\text{CH}_2)_2\text{PPh}_2$

To date, phosphine-substituted ligands seem to dominate the chemistry of heterobimetallic complexes based on Lewis-base substituted cyclopentadienes. However, a few examples have been found in the literature of complexes based on cyclopentadienyl ligands with other functionalities. For example, an acetylene-substituted ferrocene has been used to prepare an Fe-Ru complex, shown in figure 3.6.4,²⁴ and a pyridyl-functionalised ferrocene has been used to synthesis a Pd complex (shown in figure 3.6.5) with a view to preparing macrocyclic compounds containing iron and palladium.²⁵

The amine-substituted ferrocene **3.12** has two pendant amine groups available for co-ordination to a second metal, and a brief exploration of its co-ordination chemistry was carried out with the preparation of some simple heterobimetallic species.

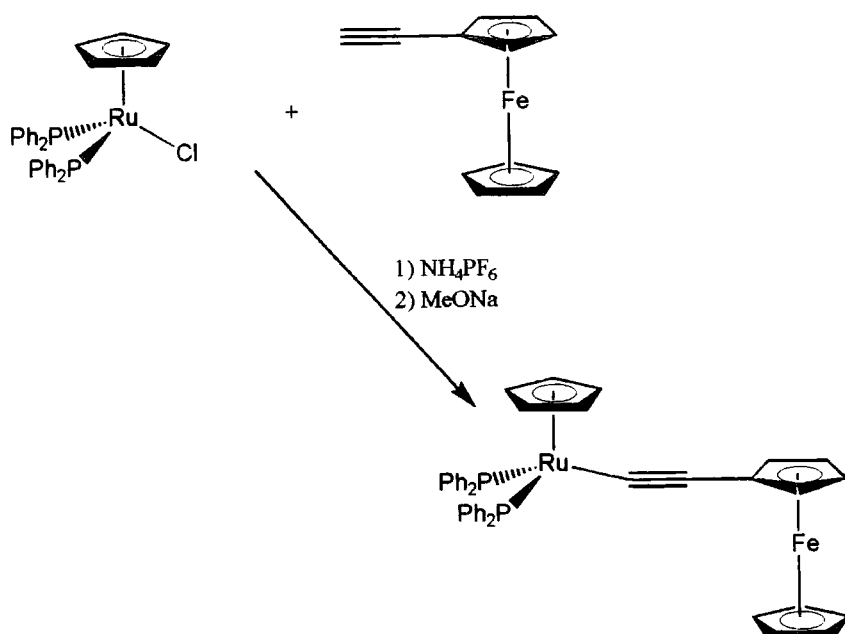

Figure 3.6.4: Iron-ruthenium heterobimetallic based on an acetylene-functionalised ferrocene

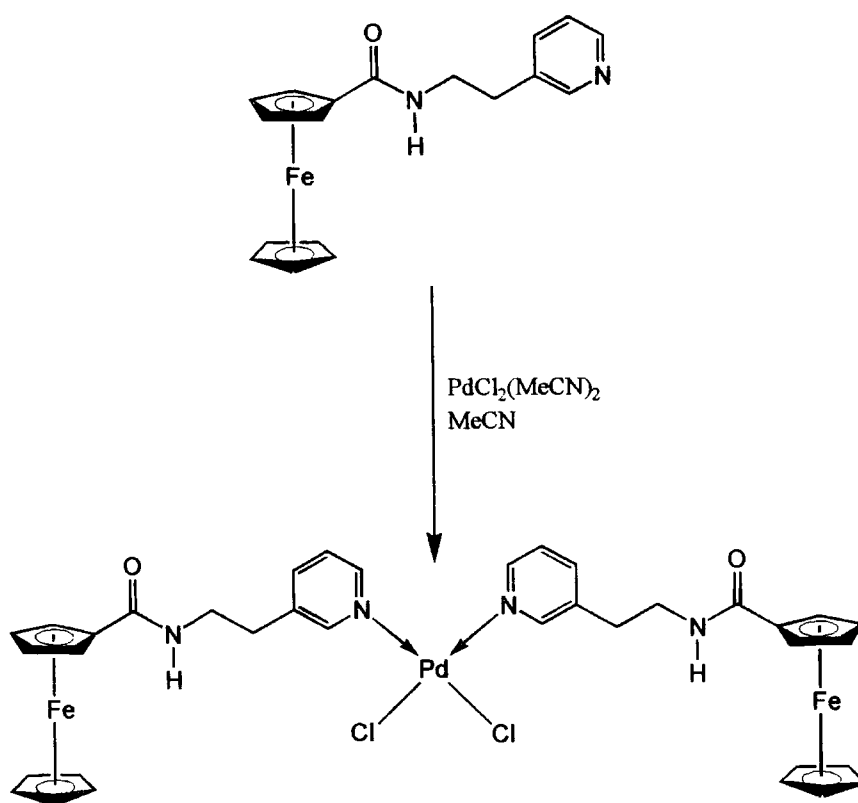

Figure 3.6.5: Heterotrimetallic based on a pyridyl-functionalised ferrocene

3.6.2: Preparation of heterobimetallics

Addition of the ferrocene, **3.12**, (as a THF solution) to a rapidly stirred suspension of MX_2 ($\text{M} = \text{Co}, \text{Ni}, \text{X} = \text{Cl}$ or $\text{M} = \text{Mn}, \text{X} = \text{Br}$) in THF gave no reaction. However, addition of a small amount of water caused immediate, exothermic reactions producing highly coloured precipitates which were filtered, washed and dried overnight under reduced pressure to remove unco-ordinated H_2O and give green **3.15** (Co), yellow **3.16** (Ni) and red-brown **3.17** (Mn) as dry, free-flowing powders. Since these compounds were paramagnetic and highly insoluble, characterisation was limited to IR spectroscopy, elemental analysis and magnetic susceptibility measurements. It is proposed that **3.12** reacts with MX_2 in the presence of H_2O to give monomeric complexes as shown in figure 3.6.6. In fact, the situation may well be considerably more complex, with oligomeric or polymeric species being formed (the insolubility of these species also suggests that they are oligomeric or polymeric). However, elemental analysis data does lend some support to the structure proposed in figure 3.6.6. IR spectroscopy shows N-H stretches and also shows H_2O to be present, even after prolonged drying of the compounds, indicating that co-ordinated water molecules are present. The IR spectrum of **3.15** is shown in figure 3.6.7 and is similar to those of **3.16** and **3.17** except for small differences in the frequencies of the major peaks.

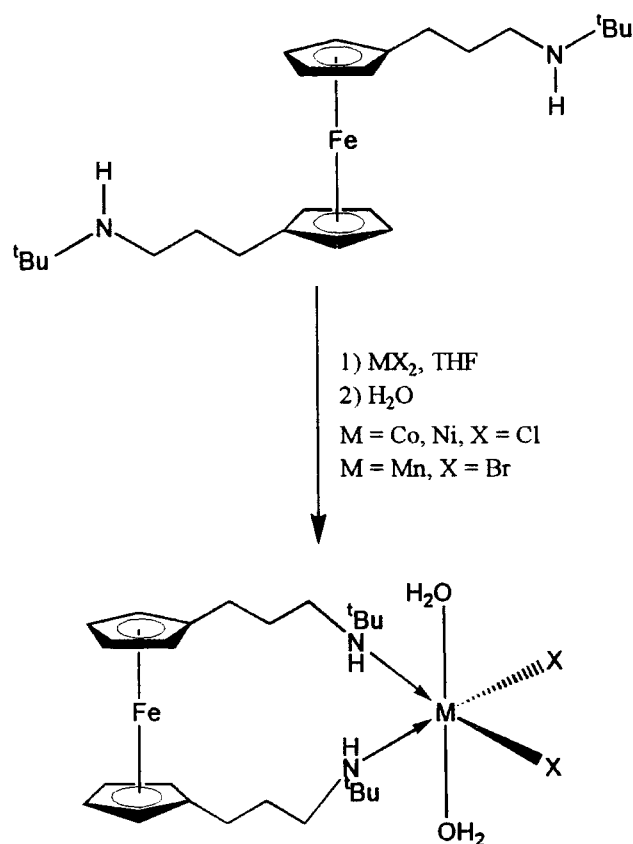

Figure 3.6.6: Reaction between 3.12 and MX_2

Solid- and solution-state magnetic susceptibility measurements of **3.15**, **3.16** and **3.17**, obtained by methods described in appendix A, are shown in table 3.6.1. Table 3.6.1 also includes measurements for $\text{HgCo}(\text{NCS})_4$, the standard compound which was used to calibrate the balance. For the purpose of these calculations the complexes were assumed to have the structures proposed in figure 3.6.6. Solid state measurements for the cobalt and nickel complexes compare well with literature values for Co^{2+} and Ni^{2+} .²⁶ That for the manganese complex is considerably lower than expected, which could be due to the presence of diamagnetic impurities in the sample. Solution state measurements were consistently lower than expected but this was thought to be due to the insolubility of the complexes which meant that these measurements were very inaccurate.

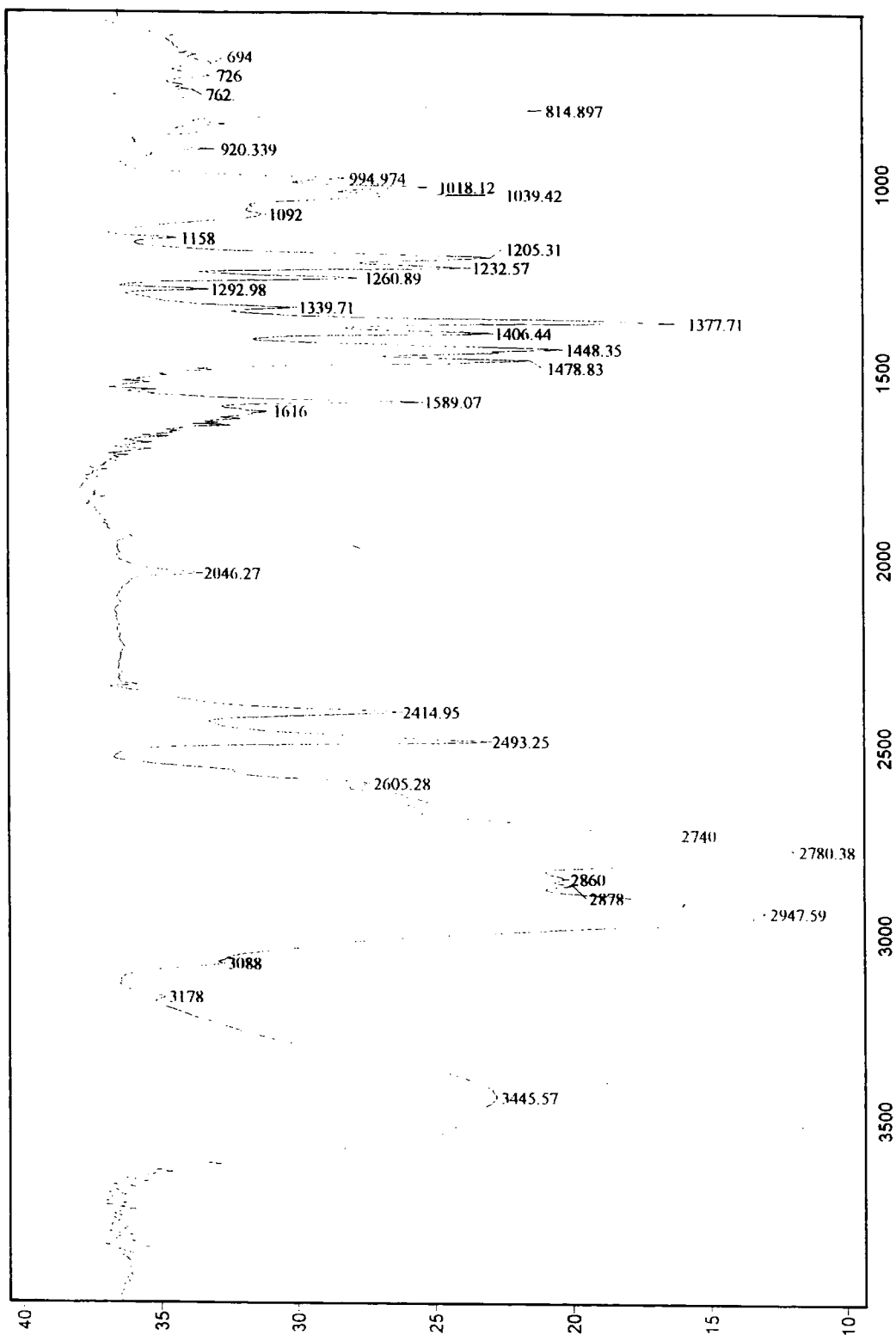

Figure 3.6.7: Infra-red spectrum of 3.15 (KBr disc)

| Complex | $\chi_M / \text{cm}^3 \text{mol}^{-1}$ (solid) | χ_M (solution) | μ_{eff} / μ_B (solid) | μ_{eff} / μ_B (solution) | μ_{eff} / μ_B (literature) |
|------------------------|---|------------------------|---------------------------------------|--|--|
| HgCo(NCS) ₄ | 8.09×10^{-3} | | 4.35 | | 4.35^{27} |
| Co | 9.48×10^{-3} | 3.56×10^{-3} | 4.68 | 2.92 | $\text{Co}^{2+} = 4.1-5.2^{26}$ |
| Ni | 4.43×10^{-3} | 3.54×10^{-3} | 3.20 | 2.91 | $\text{Ni}^{2+} = 2.8-4.0^{26}$ |
| Mn | 0.61×10^{-3} | 0.30×10^{-3} | 1.10 | 0.41 | $\text{Mn}^{2+} = \sim 5.9^{26}$ |

Table 3.6.1: Magnetic susceptibility measurements for heterobimetallic complexes

From the information obtained thus far, it is impossible to propose structures for these complexes with any certainty. Elemental analysis confirms in each case that both the expected metals are present. The structure proposed in figure 3.6.6 is almost certainly an over simplification. X-ray crystallography would provide much more information about the structure of these compounds, but due to their insolubility it has proved impossible to grow crystals suitable for X-ray studies. However, this system offers a promising route to heterobimetallic complexes. Variation of the reaction conditions, and using a different ligand in place of water may lead to the formation of characterisable, monomeric complexes.

3.7: Conclusion

Lithio and silyl derivatives of the substituted ligands 2.7 and 2.8 can be synthesised cleanly and simply by standard routes. The mono-lithium salts 3.1 and 3.3 can be used to

synthesise the substituted-ferrocene and bis(indenyl) iron (II) complexes, **3.12** and **3.14**. The substituted-ferrocene, **3.12**, can be used as a nitrogen-donor bidentate ligand for coordination to other metals, and a fuller investigation of this system may be a fruitful area for future research if the solubility and crystallinity of the resulting complexes can be improved.

3.8: References for Chapter 3

- 1) (a) P. Jutzi, J. Dalhaus, B. Neumann and H.-G. Stammer, *Organometallics*, 1996, **15**, 747; (b) P. Jutzi, J. Dalhaus and M. Bangel, *J. Organomet. Chem.*, 1994, **474**, 55; (c) P. Jutzi, H. Schmidt, B. Neumann and H.-G. Stammer, *J. Organomet. Chem.*, 1995, **499**, 7.
- 2) (a) P. Jutzi, M. O. Kristen, B. Neumann and H.-G. Stammer, *Organometallics*, 1994, **13**, 3854; (b) P. Jutzi, T. Redeker, B. Neumann and H.-G. Stammer, *J. Organomet. Chem.*, 1995, **498**, 127.
- 3) (a) U. Siemeling, O. Vorfeld, B. Neumann and H.-G. Stammer, *Chem. Ber.*, 1995, **128**, 481; (b) U. Siemeling, B. Neumann and H.-G. Stammer, *Z. Naturforsch. B*, 1995, **49b**, 683; (c) J. Okuda and K. H. Zimmermann, *J. Organomet. Chem.*, 1988, **344**, C1.
- 4) R. E. Dessey, Y. Okuzami and A. Chen, *J. Am. Chem. Soc.*, 1962, **84**, 2899.
- 5) S. H. Pine, J. B. Hendrickson, D. J. Cram and G. S. Hammond, "*Organic Chemistry*", 4th Edition, McGraw-Hill (Singapore), 1985, p200.
- 6) N. N. Greenwood and A. Earnshaw, "*Chemistry of the Elements*", Pergamon Press (Oxford), 1984, p382.
- 7) P. Jutzi and U. Siemeling, *J. Organomet. Chem.*, 1995, **500**, 175.
- 8) U. Siemeling, O. Vorfeld, B. Neumann and H.-G. Stammer, *Chem. Ber.*, 1995, **128**, 481.
- 9) (a) G. Wilkinson, *Org. Synth.*, 1956, **36**, 31; (b) W. L. Jolly, *Inorg. Synth.*, 1968, **11**, 120.
- 10) Chemical shift values for commercially produced ferrocene (Aldrich) at 250MHz in CDCl₃.
- 11) D. N. Hendrickson, Y. S. Sohn and H. B. Gray, *Inorg. Chem.*, 1971, **10**, 1559
- 12) Second Year Undergraduate Laboratory Course in Inorganic Chemistry, University of Durham, 1994, p74.

- 13) R. B. King, "*Organometallic Syntheses*", Academic Press (London), 1965, **1**, 73 and references therein.
- 14) NMR data for indene (Aldrich, tech grade) in CDCl_3 at 250MHz.
- 15) M. D. Rausch, B. H. Edwards, R. D. Rogers and J. L. Atwood, *J. Am. Chem. Soc.*, 1983, **105**, 3882.
- 16) I. Lee, F. Dehan, A. Maisonnat and R. Poilblanc, *Organometallics*, 1994, **13**, 2743.
- 17) P. J. Stang, B. Olenyuk, J. Fan and A. M. Arif, *Organometallics*, 1996, **15**, 904.
- 18) C. P. Casey, R. M. Bullock, W. C. Fultz and A. L. Rheingold, *Organometallics*, 1982, **1**, 1591.
- 19) C. P. Casey and F. Nief, *Organometallics*, 1985, **4**, 1218.
- 20) W. Tikkanen, Y. Fujita and J. L. Petersen, *Organometallics*, 1986, **5**, 888.
- 21) (a) M. D. Rausch, B. H. Edwards, R. D. Rogers and J. L. Atwood, *J. Am. Chem. Soc.*, 1983, **105**, 3882; (b) J. C. Leblanc, C. Moise, A. Maisonnat, R. Poilblanc, C. Charrier and F. Mathey, *J. Organomet. Chem.*, 1982, **231**, C43.
- 22) D. J. Harvan, J. R. Hass, K. L. Buisch, M.M. Bursey, F. Ramirez and S. Meyerson, *J. Am. Chem. Soc.*, 1979, **101**, 7410.
- 23) J. C. Leblanc, C. Moise, A. Maisonnat, R. Poilblanc, C. Charrier and F. Mathey, *J. Organomet. Chem.*, 1982, **231**, C43.
- 24) M. Sato, H. Shintate, Y. Kawata, M. Sekino, M. Katada and S. Kawata, *Organometallics*, 1994, **13**, 1956.
- 25) T. Moriuchi, I. Ikeda and T. Hirao, *J. Organomet. Chem.*, 1996, **514**, 153.
- 26) F. A. Cotton and G. Wilkinson, "*Advanced Inorganic Chemistry*", 5th Edition, John Wiley and Sons, Inc. (Chichester), 1980, p 628.
- 27) Second Year Undergraduate Course in Inorganic Chemistry, University of Durham, 1994, p7.

CHAPTER 4

Synthesis of Group 4 Complexes of Amine-Substituted Cyclopentadienyl and Indenyl Ligands by Aminolysis Reactions

4.1: Background

The work described here concerns group 4 complexes of the amine substituted cyclopentadienyl and indenyl ligands $C_5H_5(CH_2)_3NH^tBu$, **2.7**, and $C_9H_7(CH_2)_3NH^tBu$, **2.8**. This work is a development of earlier studies on zirconium and hafnium complexes of the $C_5H_5(CH_2)_3NHMe$ ligand.¹ The current work concentrates on titanium complexes of **2.7**, although some zirconium complexes of **2.7** and **2.8** were also synthesised and are reported here. Unlike the work reported in reference 1, which focused on the chemistry of group 4 halide complexes prepared *via* amide complexes, the work reported here concentrates on using amide complexes themselves as starting materials which can be used to synthesise a wide variety of new organometallic species by aminolysis reactions with weak acids. At the same time, this work was also concerned with investigating the effect on the organometallic chemistry of alkylaminopropyl cyclopentadienyl ligands when the methylamine group was replaced by the much bulkier tertiary-butyl group.

4.2: Preparation of Group 4 Amide Complexes of 2.7 and 2.8

Homoleptic group 4 metal amides such as $M(NMe_2)_4$ are known to react cleanly with one or two equivalents of cyclopentadiene, eliminating dimethylamine, Me_2NH , and giving mono- or bis-cyclopentadienyl metal amide complexes.² This reaction has already been applied successfully to the synthesis of group 4 complexes with a wide variety of ligands. Examples include titanium and zirconium complexes of $C_2B_9H_{11}^{2-}$ synthesised by reaction between $C_2B_9H_{13}$ and $M(NMe_2)_4$,³ *rac*-(ethylenebis(indenyl)) $ZrCl_2$ ⁴ and *rac*-(ethylenebis(indenyl)) $Zr(NR_2)_2$,⁵ Me_2Si -bridged *ansa*-zirconocenes⁶ and Me_2Si bridged bis(indenyl)zirconium complexes such as *rac*- $Me_2Si(indenyl)_2Zr(NMe_2)_2$.⁷ The reaction has

also been applied to the synthesis of zirconium complexes of amine-substituted cyclopentadienyl ligands⁸ including the complex of $C_5H_5(CH_2)_3NHMe$ shown in figure 1.4.9.¹ It can be seen that this aminolysis reaction is extremely versatile and can be used to synthesise group 4 complexes of a wide variety of ligands, and it can also be adapted to the synthesis of complexes of other early transition metals including group 5 and 6 complexes of the $CpSiMe_2NR$ ligand formed by the reactions shown in figure 1.4.14 between $CpHSiMe_2NHR$ and $M(NMe_2)_5$ ($M = Nb, Ta$)⁹ or $Mo(NMe_2)_4$.¹⁰

The advantages of the aminolysis route for the metallation of cyclopentadienes are that it is a simple, one stage procedure and that the elimination product (dimethylamine) is gaseous and easily removed from the reaction, thus making purification of the final product easier. The disadvantages are that the group 4 metal amides $M(NMe_2)_4$ required for this reaction are time-consuming to prepare,^{11, 12} and in the case of $Zr(NMe_2)_4$ could only be prepared in variable yields (see section 5.1.4); and that at first sight cyclopentadienyl metal amides appear to be less versatile and useful as starting materials than do cyclopentadienyl metal chlorides.

4.2.1: Preparation of group 4 amide complexes of 2.7

The amine-substituted cyclopentadiene 2.7 reacts quickly and cleanly with a toluene solution of $Ti(NMe_2)_4$ or $Zr(NMe_2)_4$ (prepared by literature methods^{12, 13} as described in chapter 5) to give the desired titanium and zirconium dimethylamide complexes 4.1 and 4.2 as highly air- and moisture-sensitive brown-yellow and yellow oils respectively as shown in figure 4.2.1.

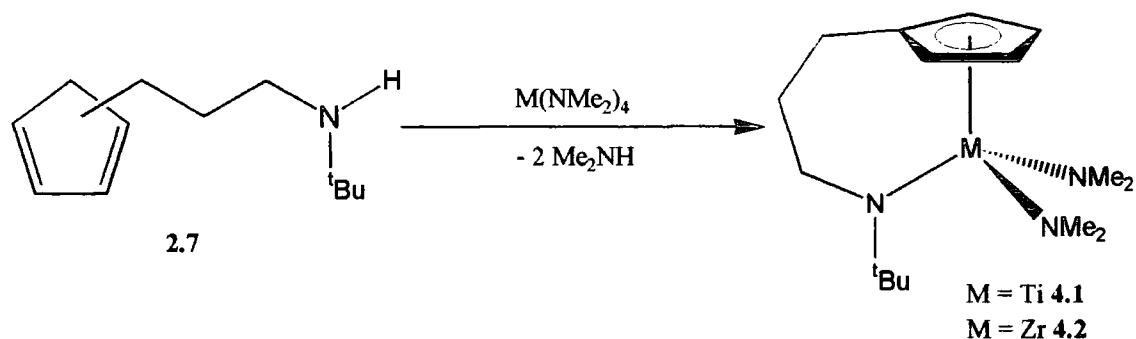

Figure 4.2.1: Preparation of group 4 amide complexes 4.1 and 4.2

The 1H and ^{13}C NMR spectra of these oils (those of the titanium complex **4.1** are shown in figures 4.2.2 and 4.2.3 respectively) indicated that they were the desired complexes **4.1** and **4.2**. The 1H NMR spectrum of the titanium complex **4.1**, shown in figure 4.2.2, indicates that two NMe_2 ligands have been displaced from $Ti(NMe_2)_4$, as the peaks assigned to the $N(CH_3)_2$ and $C(CH_3)_3$ protons give integrals of 12 and 9 respectively. The complex signals seen in the aromatic region of the 1H NMR spectrum of the free ligand **2.7** have simplified into an AA'BB' spin system, indicating that the cyclopentadiene ring has undergone deprotonation and is now co-ordinated to the metal centre. The $^{13}C\{^1H\}$ NMR spectrum of **4.1**, shown in figure 4.2.3, shows two signals for the cyclopentadienyl CH groups. The signal due to the *ipso*-carbon of the cyclopentadienyl ring is too weak to be visible, but all other expected signals are present. As expected, IR spectroscopy did not show any peaks which could be attributed to N-H stretches, confirming metallation of the secondary amine. The 1H and $^{13}C\{^1H\}$ NMR and the IR spectra of the zirconium complex **4.2** gave similar results. Both the titanium and zirconium complexes remain liquid even at low temperatures, ruling out X-ray crystallography as a method of characterisation. The titanium complex **4.1** proved unstable under mass-spectroscopy conditions, and although

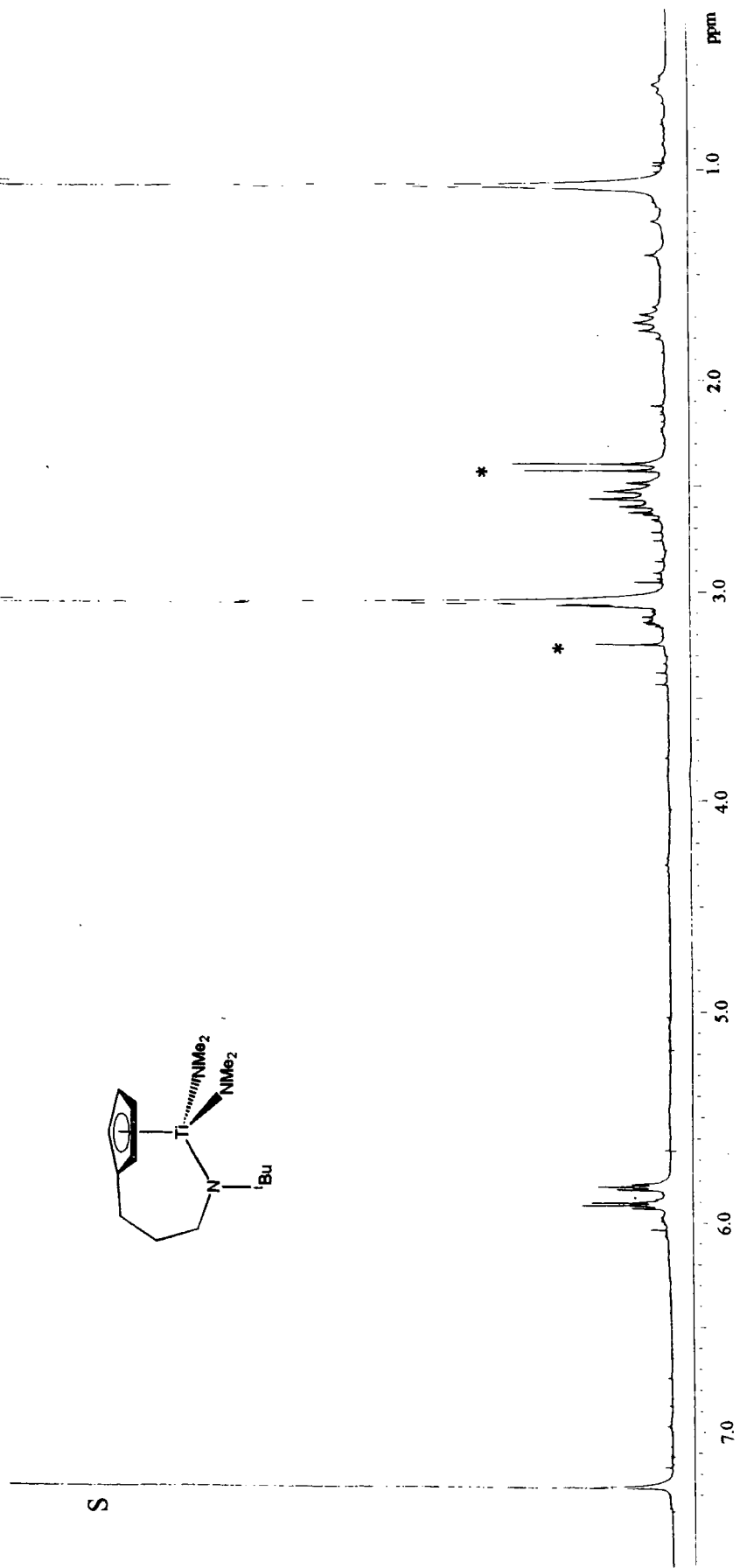

Figure 4.2.2: The ^1H NMR spectrum of 4.1 at 200MHz in CDCl_3 . Residual protio solvent peak marked S, impurities marked *

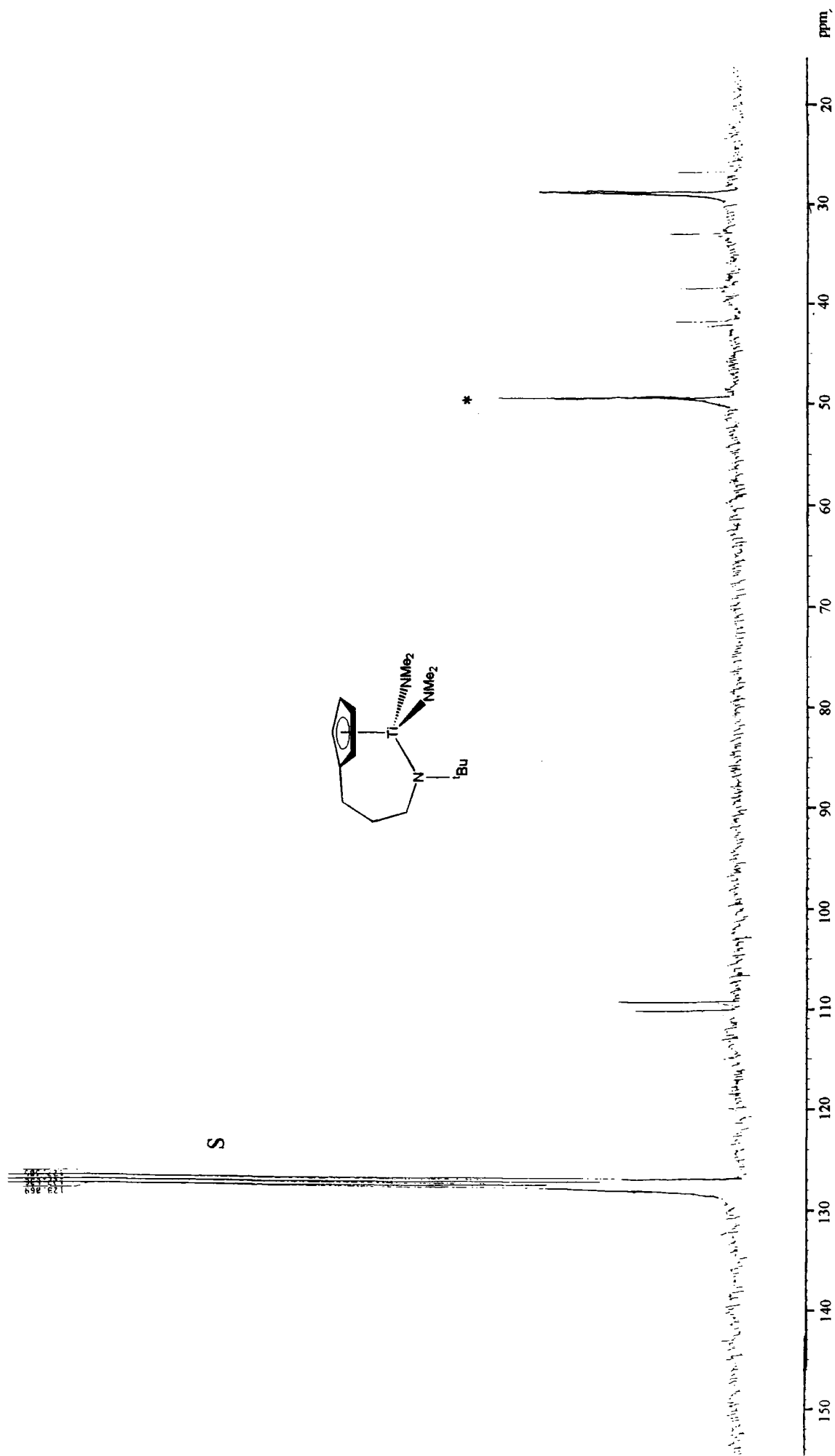

Figure 4.2.3: The $^{13}\text{C}\{^1\text{H}\}$ NMR spectrum of 4.1 at 62.5MHz in CDCl_3 . Solvent peak marked **S, dimethylamine impurity marked ***

the molecular ion can be clearly seen (mass 313) under chemical ionisation conditions, under electron impact conditions a second peak appears at mass 402. This is thought to be due to the bis(cyclopentadienyl) species **4.1a** which is formed by rearrangement of **4.1** under these conditions (see section 4.2.2) and is proposed to have the structure shown in figure 4.2.6. This spectrum also contains a peak at mass 224 which is thought to correspond to $\text{Ti}(\text{NMe}_2)_4$ formed during the rearrangement.

4.2.2: Rearrangement of 4.1 and 4.2 on heating

Compatible with the observed rearrangement under mass spectroscopy conditions, attempted reduced pressure distillation of the titanium complex, **4.1**, led to decomposition of the product before distillation temperature was reached. The decomposition product consisted of a dark brown, highly air sensitive solid, **4.1a**, which was characterised by NMR spectroscopy. ^1H and $^{13}\text{C}\{^1\text{H}\}$ NMR spectra (shown in figures 4.2.4 and 4.2.5 respectively) indicate two C_2 -related C_5H_4 groups with the four hydrogen atoms inequivalent. The peak assigned to the NMe_2 groups has moved to a slightly lower frequency, consistent with $\text{Ti}(\text{NMe}_2)_4$ (δ ^1H , 250MHz, CDCl_3 = 3.09 ppm).¹³ In addition to this, two different signals could be seen for the tertiary-butyl group and for the backbone. From this data it is proposed that **4.1** is thermally unstable and on heating undergoes a rearrangement to give $\text{Ti}(\text{NMe}_2)_4$ and a bis(cyclopentadienyl) species, **4.1a**, with the structure shown in figure 4.2.6. The proposed structure of **4.1a** is consistent with the available NMR data. Bearing in mind earlier work on this type of compound in which zirconium and hafnium complexes of the methylaminopropyl cyclopentadienyl ligand had been shown to distil cleanly and in high yield,¹ it was expected that the zirconium complex, **4.2**, would prove more stable to

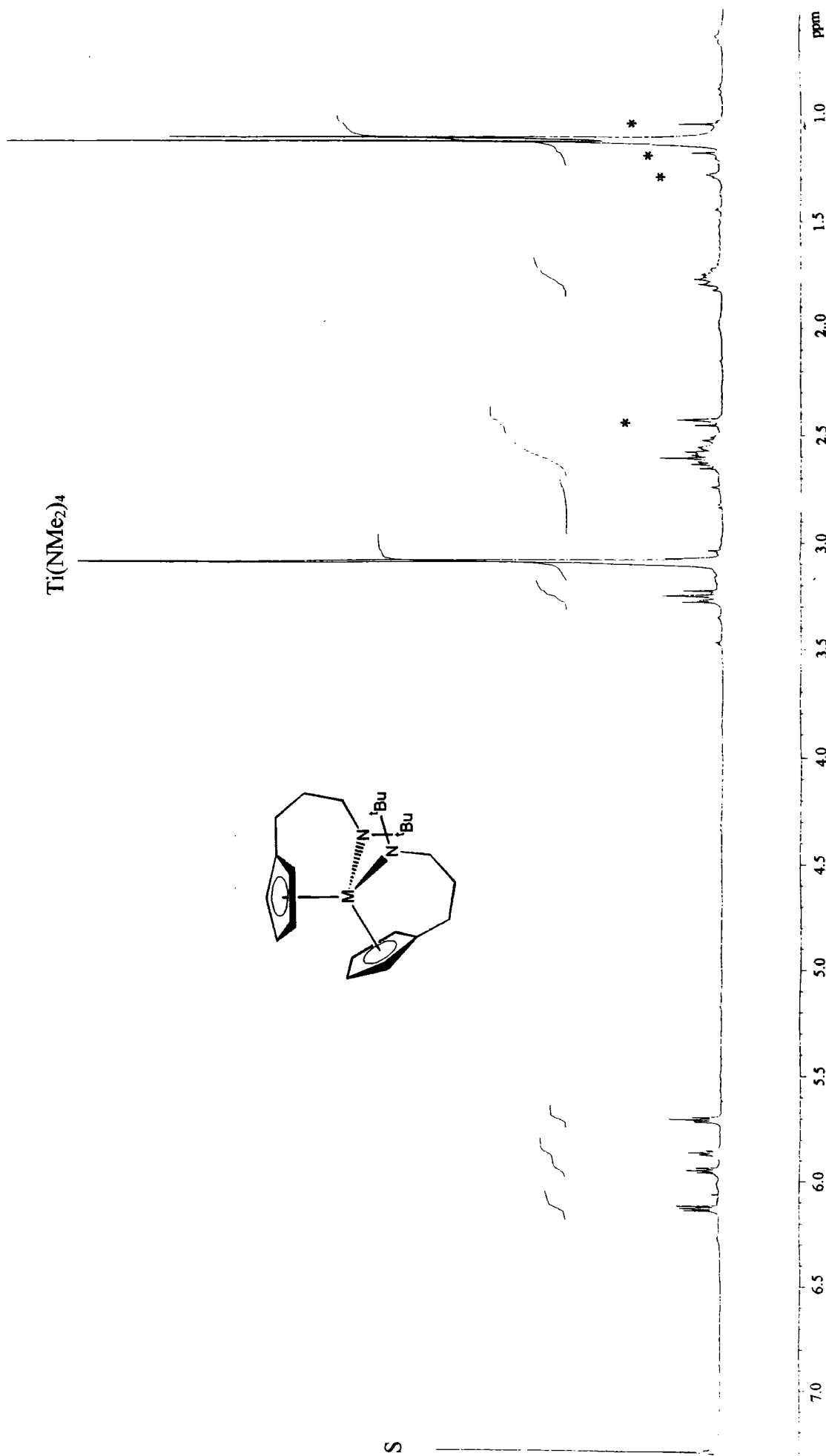

Figure 4.2.4: The ^1H NMR spectrum of 4.1a at 250 MHz in CDCl_3 (marked S). Unidentified impurities marked *

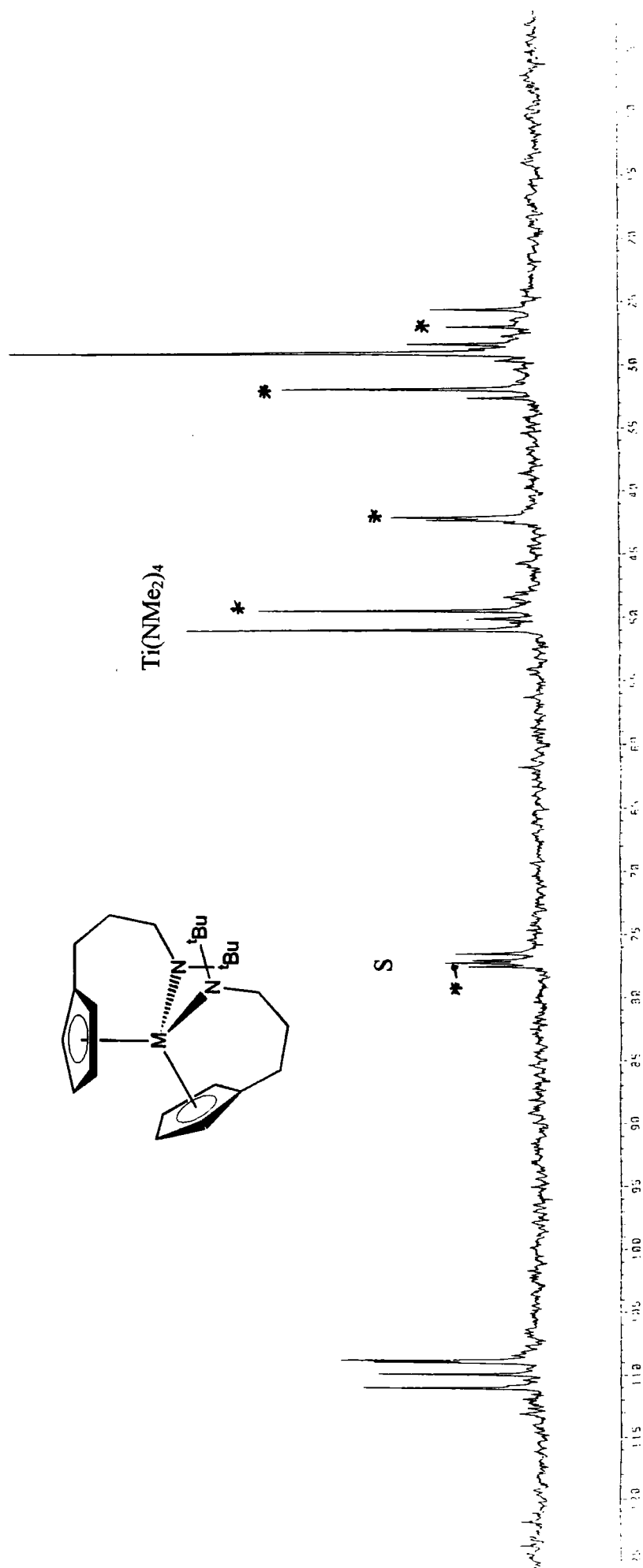

Figure 4.2.5: The $^{13}\text{C}\{^1\text{H}\}$ NMR spectrum of 4.1a at 62.5 MHz in CDCl_3 . Solvent marked S, unidentified impurities marked *

distillation. However, attempted reduced pressure distillation of this complex caused decomposition in an identical manner to that of 4.1 to give a pale brown oil 4.2a which gave similar ^1H and $^{13}\text{C}\{^1\text{H}\}$ NMR spectra to those of 4.1a. Again it is proposed that the complex undergoes re-arrangement as shown in figure 4.2.6. It is not fully understood why these complexes should behave in this manner on heating, especially bearing in mind the ease of distillation of analogous complexes of the methylaminopropyl cyclopentadienyl ligand as described in reference 1. It is possible that replacement of the methylamino group with a tertiarybutylamino group is sufficient to raise the distillation temperatures of these compounds above their decomposition temperatures.

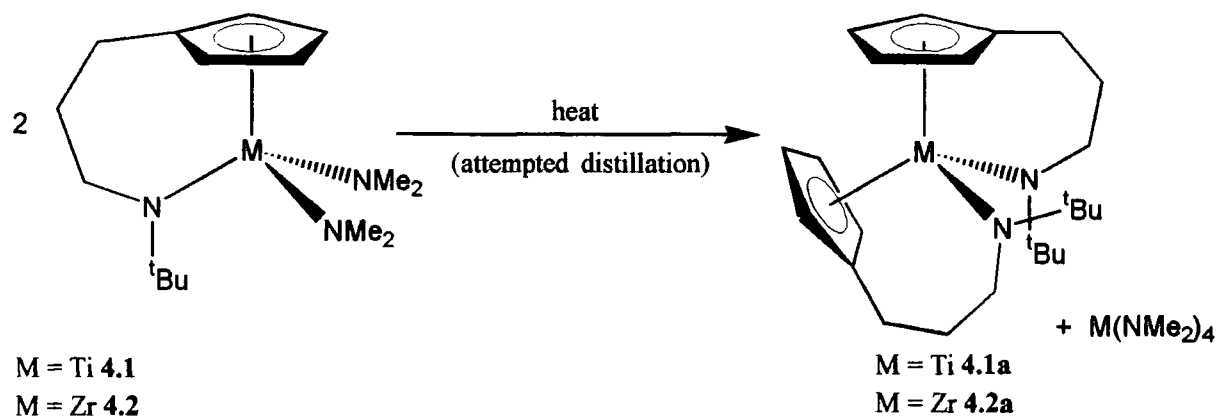

Figure 4.2.6: Proposed re-arrangement of 4.1 and 4.2 on distillation

4.2.3: Preparation of a zirconium amide complex of the substituted indenyl ligand, 2.8

In an NMR reaction, the titanium amide $\text{Ti}(\text{NMe}_2)_4$ failed to react with one equivalent of the amine substituted indene, 2.8, in C_6D_6 , despite prolonged heating to 60°C . Reaction also failed to take place between these compounds when heated to 90°C in toluene for over a week in a Schlenk tube which was regularly evacuated to remove any liberated

NHMe₂ gas. The failure of this reaction is probably due to the fact that the small size of the titanium metal centre inhibits formation of the transition state in the reaction with the bulky indene (discussed further below).

In contrast, reaction between **2.8** and Zr(NMe₂)₄ in toluene at 60°C over 7 days gave a red-brown, highly air sensitive oil, **4.3**, which was characterised by ¹H, ¹³C{¹H} and ¹³C NMR spectroscopy. The ¹H NMR spectrum shows a complex multiplet for the C-H protons of the 6-membered ring, and an AB system for the two C-H protons of the five membered ring. The ¹³C{¹H} and ¹³C NMR spectra were of poor quality due to the fact that the compound was prepared in very small amounts and NMR samples were very dilute, but on the basis of ¹H NMR data it is proposed that the aminolysis reaction takes place as shown in figure 4.2.7 giving the zirconium indenyl complex **4.3**, presumably as a mixture of both enantiomers although they are indistinguishable by ¹H NMR. The ¹H NMR spectrum shows that some unreacted **2.8** is present as an impurity and this was difficult to remove since distillation led to decomposition of the zirconium product. However, this does not necessarily make **4.3** an unsuitable starting material for further chemistry, particularly if it could be converted into a solid, crystalline derivative which would be more easily purified.

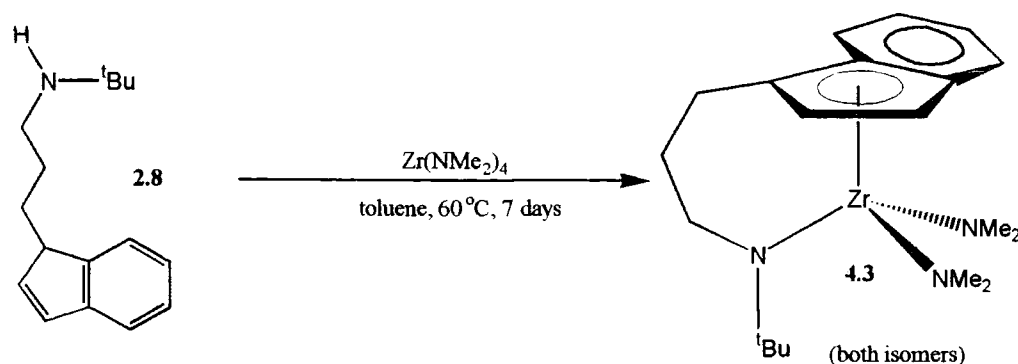

Figure 4.2.7: Reaction between **2.8** and Zr(NMe₂)₄

These reactions indicate that the substituted indenyl ligand, **2.8**, does not react with $\text{Ti}(\text{NMe}_2)_4$ but does react with $\text{Zr}(\text{NMe}_2)_4$, although the reaction is slow and incomplete. This is in accordance with the findings of Lappert,¹ who found that the reaction between homoleptic group 4 amides $\text{M}(\text{NMe}_2)_4$ and acidic hydrocarbons such as cyclopentadiene and indene is extremely sensitive to steric effects, so that $\text{Zr}(\text{NMe}_2)_4$ reacted with one equivalent of indene to give $(\eta^5\text{-C}_9\text{H}_7)\text{Zr}(\text{NMe}_2)_3$ but $\text{Ti}(\text{NMe}_2)_4$ failed to react because formation of the transition state is sterically hindered due to the small size of the titanium metal centre and the bulkiness of indene.

4.3: Attempted Conversion of the Amide Complexes 4.1 and 4.2 to Halides

Metal halides are generally considered to be more useful starting materials than metal amides since they can be used to prepare a variety of interesting complexes, particularly metal alkyls. It was therefore hoped to be able to convert the titanium and zirconium amide complexes to halides by reaction with dimethylammonium halides, $\text{Me}_2\text{NH}_2\text{X}$ ($\text{X} = \text{Cl}, \text{Br}, \text{I}$) as shown in figure 4.3.1. The dimethylammonium halides act as anhydrous sources of HX which can be weighed and used stoichiometrically. This has been used very successfully to convert $\{\eta^5\text{-}\sigma\text{-(C}_5\text{H}_4\text{)(CH}_2\text{)}_3\text{NMe}\}\text{Zr}(\text{NMe}_2)_2$ to $\{\eta^5\text{-}\sigma\text{-(C}_5\text{H}_4\text{)(CH}_2\text{)}_3\text{NMe}\}\text{Zr}(\text{NHMe}_2)\text{X}_2$ ¹ However, reaction between the metal amide complexes **4.1** and **4.2** and $\text{Me}_2\text{NH}_2\text{X}$ ($\text{X} = \text{Cl}, \text{Br}, \text{I}$) failed to yield any characterisable products, despite repeated attempts and variation of solvent, reaction conditions, and halogen. It is not known why these reactions failed, and their failure led to subsequent work being concentrated on the metal amides as starting materials. The conversion of **4.3** into a halide complex by this route has not been attempted.

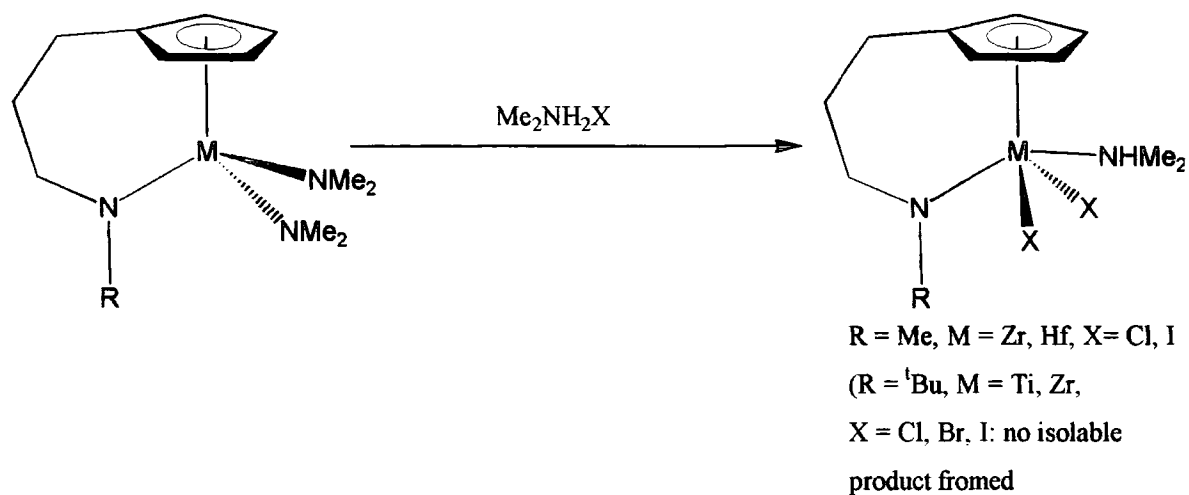

Figure 4.3.1: Potential conversion of group 4 metal amides to halides using $\text{R}_2\text{NH}_2\text{X}$

4.4: Attempted Preparations of Group 4 Metal Halide Complexes of 2.7

Although the aminolysis route is a simple and highly efficient way of synthesising group 4 complexes of the substituted cyclopentadiene, **2.7**, it was hoped that it would also be possible to synthesise group 4 halide complexes of this ligand by a direct route, especially bearing in mind the difficulties encountered in converting the group 4 amide complexes **4.1** and **4.2** into halides. The traditional route to cyclopentadienyl and bis(cyclopentadienyl) halide complexes of group 4 is reaction between lithiated or silylated cyclopentadienes and the metal tetrachloride. Both lithiated¹⁴ and silylated¹⁵ cyclopentadiene derivatives have been successfully used in the preparation of group 4 halide complexes of Lewis-base substituted cyclopentadienes, and some examples are shown in figure 4.4.1.

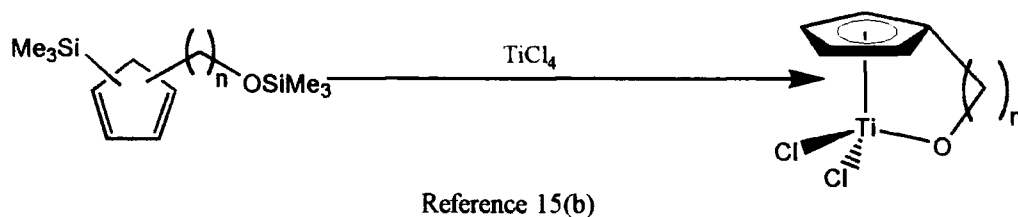
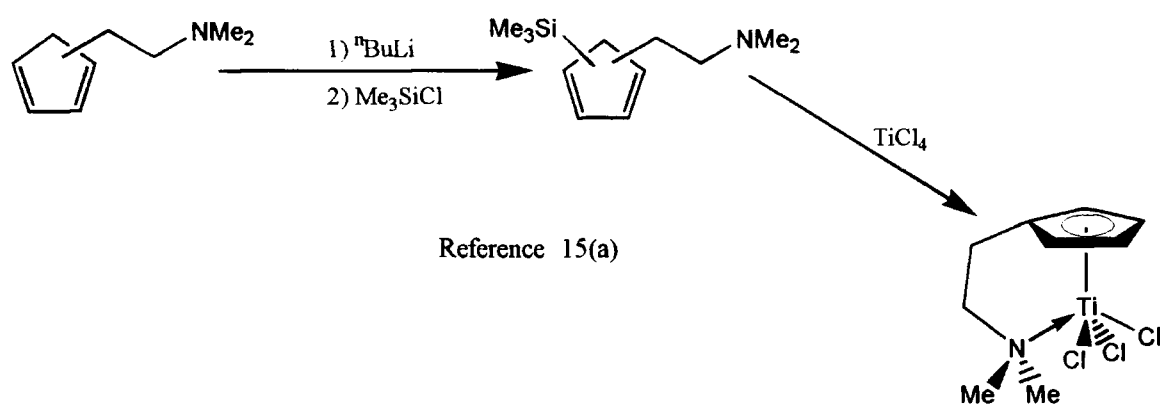
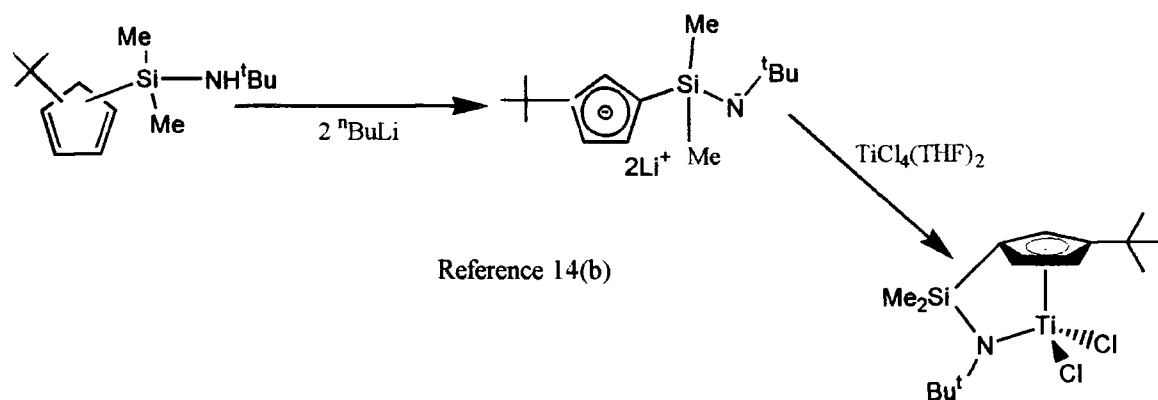

Figure 4.4.1: Preparation of group 4 complexes *via* lithiated and silylated cyclopentadiene derivatives

It was hoped that one or both of these methods might prove suitable for the preparation of titanium complexes of **2.7** by the reaction proposed in figure 4.4.2. Addition of TiCl_4 to a toluene solution of the bis(silyl) derivative, **3.7**, at -78°C caused immediate reaction with the solution changing colour from yellow to dark red. However, on work-

up a dark, insoluble solid was obtained which proved impossible to characterise due to its insolubility. Reaction between the di-lithium salt, **3.3**, and $\text{TiCl}_4(\text{THF})_2$ in THF solution yielded similar results. It is possible that the products of these reactions were polymeric. Various modifications of solvent, reaction temperature and reaction time failed to produce the desired complex, and it was concluded that this route was not applicable to the preparation of titanium complexes of **2.7**, so that an alternative route had to be sought.

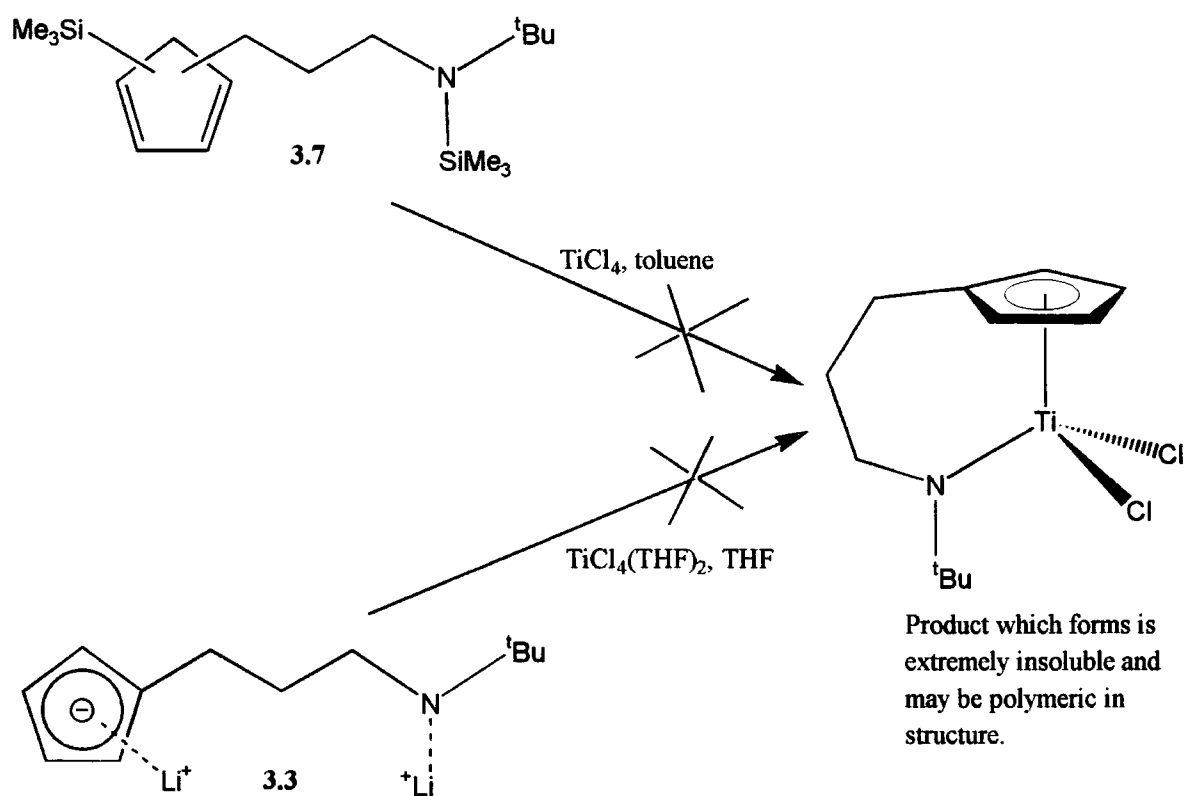

Figure 4.4.2: Proposed route to titanium chloride complexes of **2.7**

4.5: Aminolysis Reactions of 4.1 and 4.2

The amide complexes 4.1 and 4.2 are themselves potential starting materials for a wide variety of other complexes since they can undergo further aminolysis reactions with a wide range of acids. The pK_a of secondary amines HNR_2 is in the range 35-40,¹⁶ and thus transition metal amides, $M-NR_2$, will react with a wide range of weak acids. Reactions between the homoleptic group 4 metal amides, $M(NMe_2)_4$, or the cyclopentadienyl metal amides $Cp_2M(NMe_2)_2$ and various weak acids have been studied and are summarised in figure 4.5.1.² It was expected that the metal-dimethylamide complexes 4.1 and 4.2 would undergo similar reactions with weak acids.

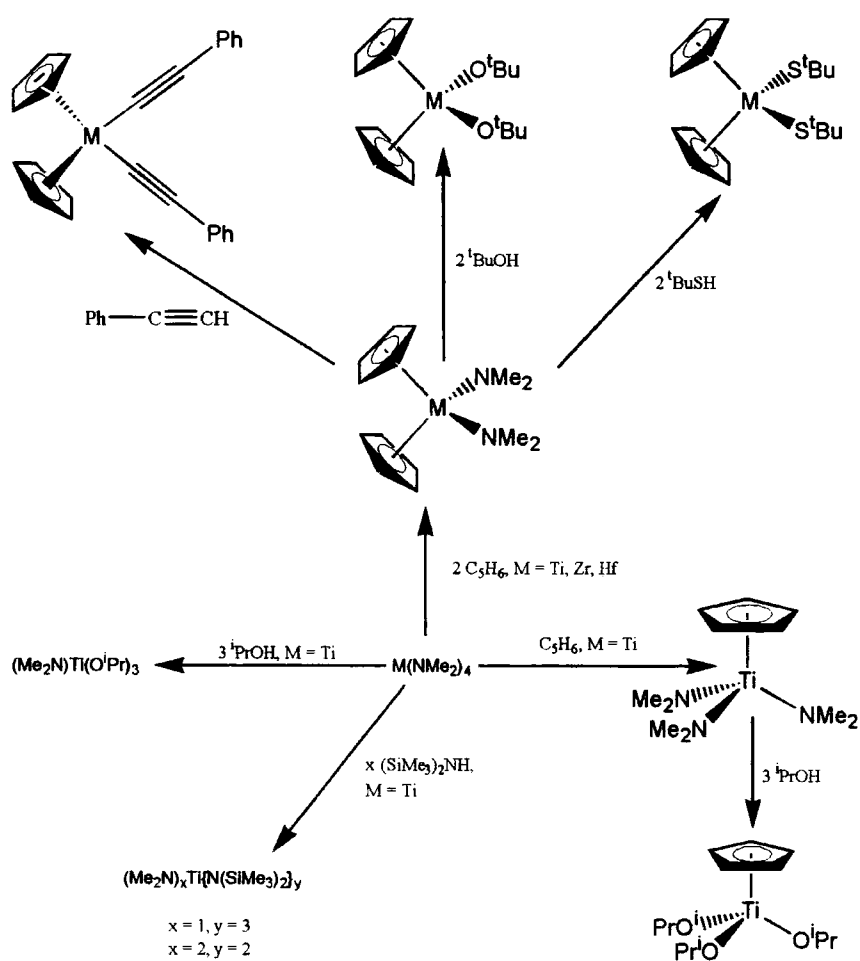

Figure 4.5.1: Reactions between group 4 metal amide complexes and weak acids

4.5.1: Reaction between 4.1 and propan-2-ol

Compound 4.1 reacts rapidly and cleanly with dry propan-2-ol to give the bis(isopropoxide) complex, 4.4. This compound was characterised by ^1H and $^{13}\text{C}\{^1\text{H}\}$ NMR spectroscopy and IR spectroscopy. The ^1H NMR spectrum, shown in figure 4.5.2, clearly shows that the singlet due to the NMe_2 groups has disappeared and been replaced by a septet at 4.6 ppm and a doublet at 1.17 ppm corresponding to the CH and CH_3 protons of the isopropyl groups. No signals due to NMe_2 groups are present, but a trace of propan-2-ol is present as an impurity. The $^{13}\text{C}\{^1\text{H}\}$ NMR spectrum is shown in figure 4.5.3, and as expected shows two signals due to the C-H carbons of the cyclopentadienyl ring at 110.0 and 110.5 ppm (the signal due to the *ipso* carbon is too weak to be seen), the $\underline{\text{CH}}$ and $\underline{\text{CH}_3}$ carbons of the isopropoxide group appear at 77.6 and 28.9 ppm, and again no signals due to NMe_2 groups are present. IR spectroscopy showed no N-H or O-H absorptions, but did show absorptions characteristic of a co-ordinated cyclopentadienyl ring at 1230, 1160 and 990 cm^{-1} . Like the amide complex 4.1, compound 4.4 is unstable under mass-spectroscopy conditions, and the parent molecular ion ($\text{RMM} = 344$) appears only as a very weak signal indeed. The mass spectrum does show strong peaks due to some other identifiable fragments, notably $\text{C}_5\text{H}_5(\text{CH}_2)_3\text{NH}^t\text{Bu}$ (mass 179) and the $\text{OCH}(\text{CH}_3)_2$ fragment (mass 59).

Since 4.4 remains a liquid even down to low temperatures, it could not be characterised by X-ray diffraction. However, on the basis of other data, particularly ^1H and $^{13}\text{C}\{^1\text{H}\}$ NMR spectroscopy, it is possible to conclude with reasonable certainty that the reaction proceeds as shown in figure 4.5.4 to give the bis(isopropoxide) complex 4.4.

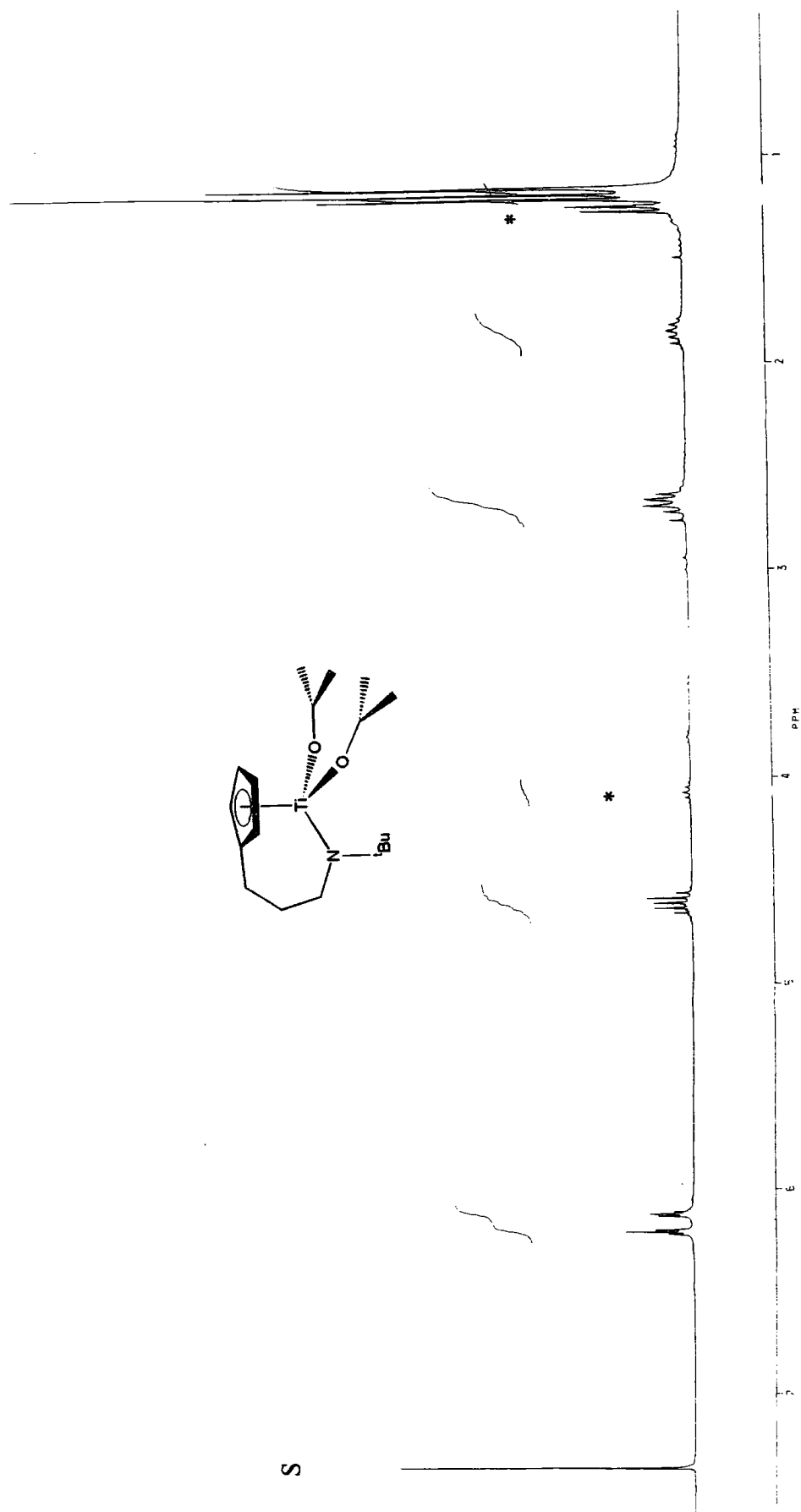

Figure 4.5.2: The ^1H NMR spectrum of 4.4 at 250 MHz in CDCl_3 , solvent marked S, $^i\text{PrOH}$ impurity marked *

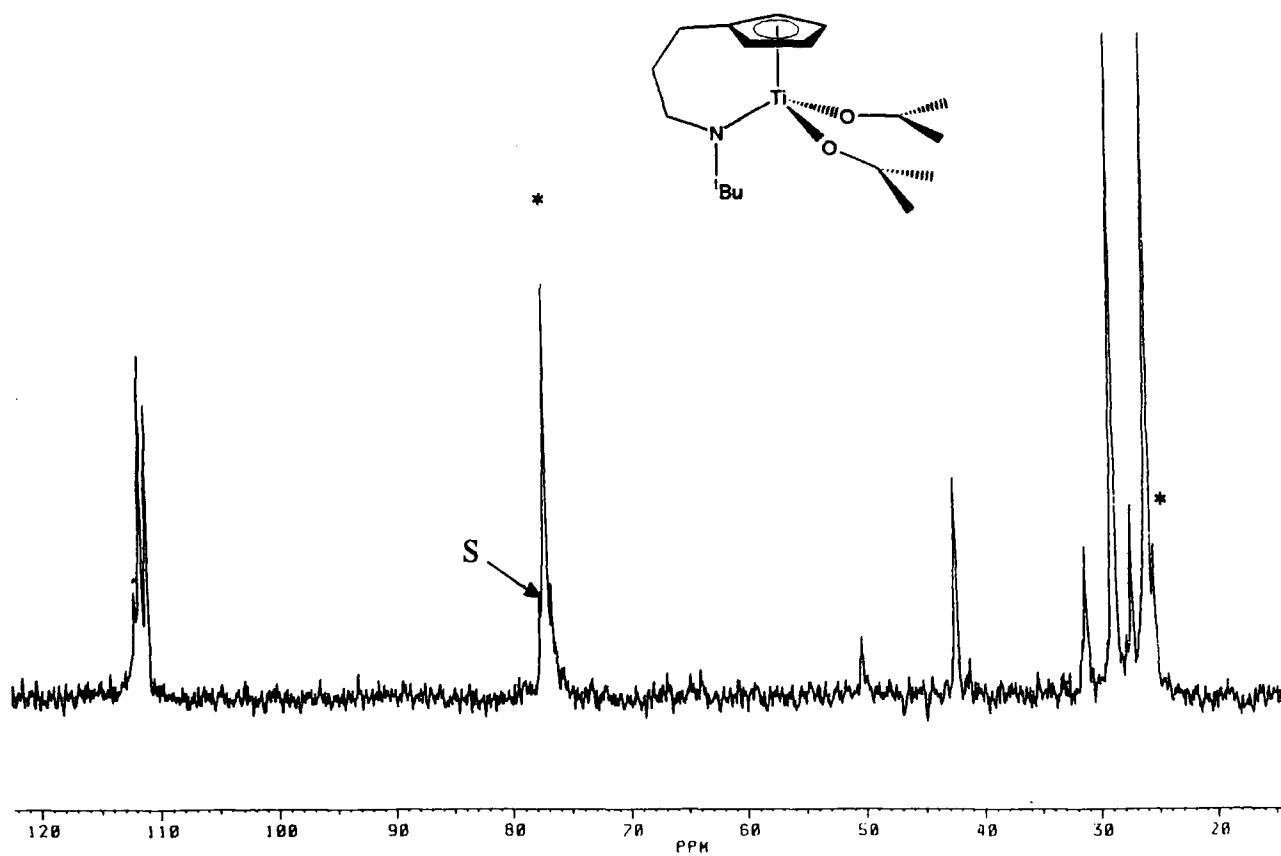

Figure 4.5.3: The 62.5 MHz $^{13}\text{C}\{^1\text{H}\}$ NMR spectrum of 4.4 in CDCl_3 with solvent marked S and impurities marked *

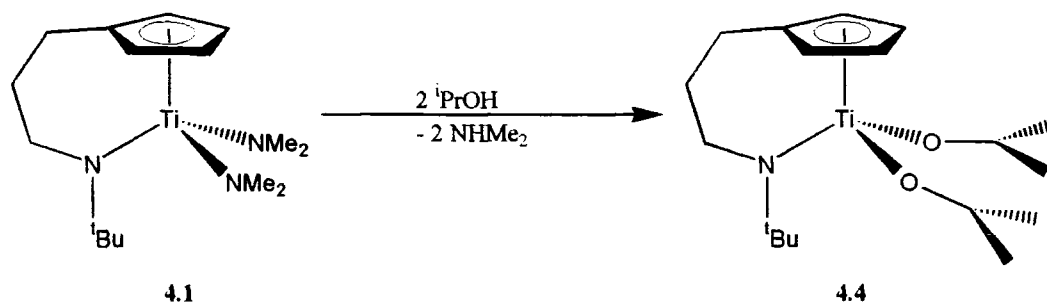

Figure 4.5.4: Reaction between 4.1 and propan-2-ol

4.5.2: Reaction between 4.1 and ^tBuSH

The amide complex 4.1 reacts rapidly and cleanly with tertiary-butyl thiol to give a deep red oil, 4.5, characterised by NMR spectroscopy. Since compound 4.5 smelled strongly of ^tbutyl thiol, it was handled in a fume hood at all times.

The ¹H and ¹³C{¹H} NMR spectra of 4.5, shown in figures 4.5.5 and 4.5.6 respectively, show that the NMe₂ groups have been replaced by S^tBu groups. In the ¹H NMR spectrum, the NMe₂ signal of 4.1 has disappeared and been replaced by a singlet at 1.61 ppm corresponding to the C(CH₃)₃ protons of the tertiary-butyl thiol group, and a small quantity of free tertiary-butyl thiol is present as an impurity. Like the isopropoxide complex 4.4, this complex remains liquid even down to low temperatures and so is not characterisable by X-ray diffraction. However, on the basis of the NMR data it is possible to conclude that the aminolysis reaction has taken place as shown in figure 4.5.7 to give the bis(tertiarybutyl thiol) complex 4.5. This compound gave better quality mass spectra than either 4.1 or 4.4, with the parent molecular ion clearly visible at mass 404 under chemical ionisation conditions. A peak at 315 corresponds to loss of one SC(CH₃)₃ fragment.

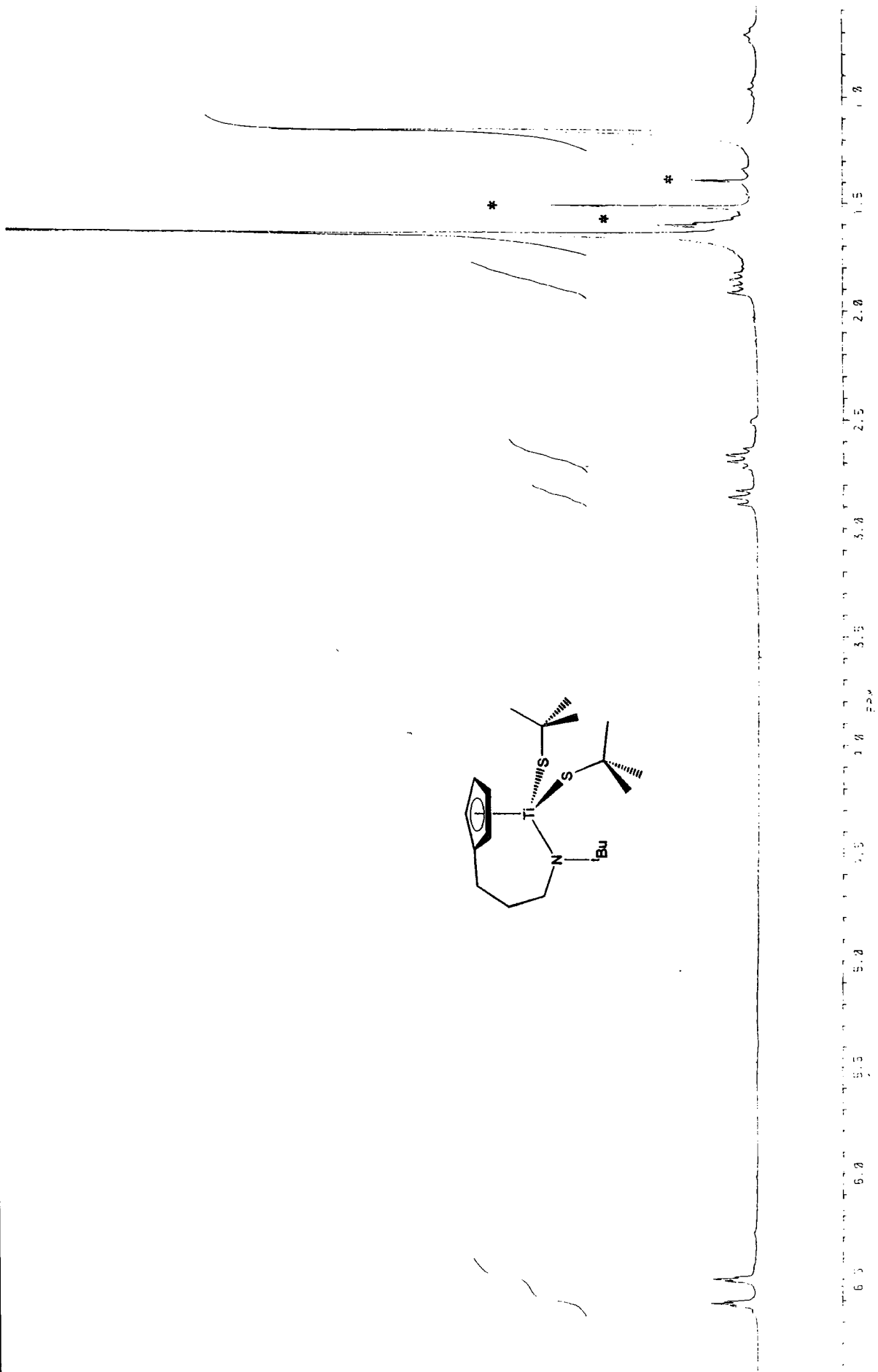

Figure 4.5.5: The 250MHz ¹H NMR spectrum of 4.5 in CDCl₃, impurities marked *

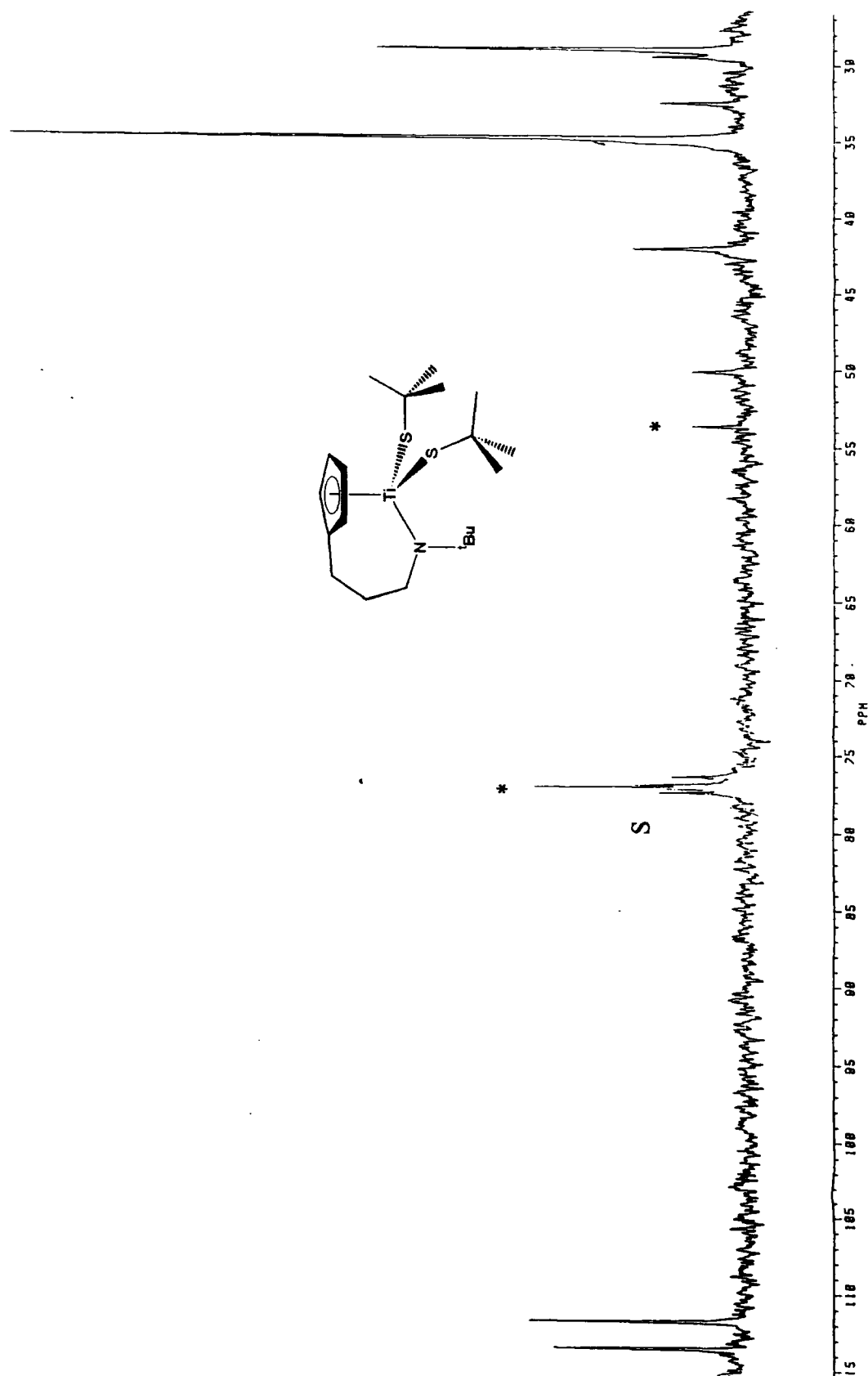

Figure 4.5.6: The $^{13}\text{C}\{^1\text{H}\}$ NMR spectrum of 4.5 at 62.5MHz in CDCl_3 , solvent marked S, impurities marked *

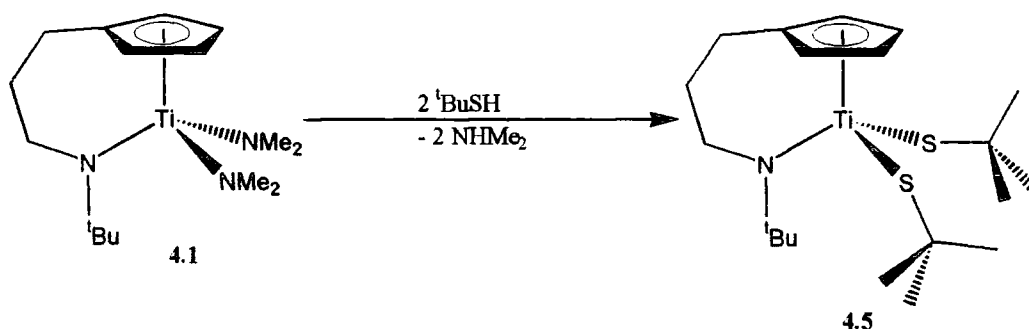

Figure 4.5.7: Reaction between 4.1 and ^tBuSH

4.5.3: Reaction between 4.1 and C₅H₆

Compound **4.1** reacts with one equivalent of C₅H₆ to give the mixed bis(cyclopentadienyl) complex **4.6** as a viscous brown oil, which proved to be very difficult to purify, since attempted distillation or sublimation led to decomposition to give unidentified species. However, a sample of this product characterisable by ¹H and ¹³C{¹H} NMR and IR spectroscopy was obtained by careful extraction of the reaction product using various solvents (see section 5.4.4). In addition to the two triplets corresponding to the protons of the substituted cyclopentadienyl ring, the ¹H NMR spectrum shows a singlet at 6.04ppm corresponding to the protons of the unsubstituted cyclopentadienyl ring. The singlet corresponding to the NMe₂ protons has decreased in intensity relative to the singlet corresponding to the ^tbutyl protons, so that the ratio of NMe₂: C(CH₃)₃ is now 6:9, indicating displacement of one NMe₂ ligand from the starting complex. Since the complex is so difficult to purify, and since only very small amounts were ever obtained, characterisation was essentially limited to ¹H and ¹³C{¹H} NMR spectroscopy. From the NMR data it is proposed that the reaction shown in figure 4.5.8 has taken place to give the mixed cyclopentadienyl complex **4.6**. However, this reaction was unreliable and repeated

syntheses did not always give the same product. Purification of **4.6** was problematic since distillation led to decomposition, and the highly air- and moisture-sensitive nature of the product (as well as the small quantities obtained) make chromatography difficult.

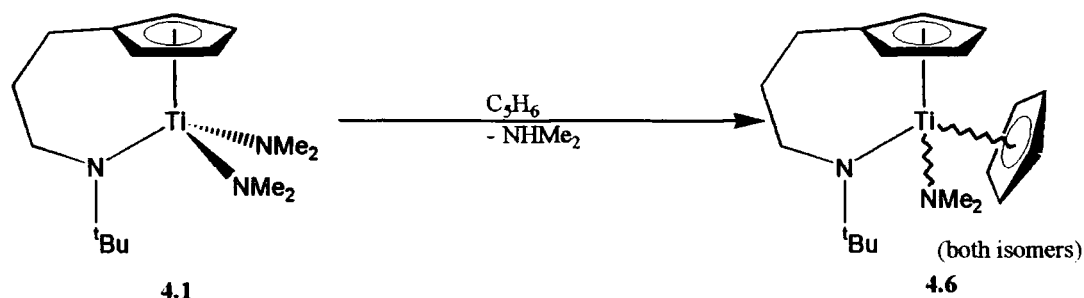

Figure 4.5.8: Reaction between 4.1 and C_5H_6

In a similar reaction carried out in an NMR tube, **4.1** failed to react with indene, even though indene is in theory a strong enough acid to displace an amide ligand (pK_a of indene in MeOH = 18).¹⁷ It is thought that this is due to steric factors, because the titanium metal centre is too small to accommodate a bulky indenyl ligand in addition to the substituted cyclopentadienyl already present. This is in accordance with the early work carried out on the homoleptic group 4 amides $Ti(NMe_2)_4$ and $Zr(NMe_2)_4$ where the aminolysis reaction between the amides and acidic hydrocarbons such as cyclopentadiene and indene was found to be highly sensitive to steric factors, as has already been discussed in 4.3.3.²

4.5.4: Reaction between 4.1 and ${}^n\text{Bu}_3\text{SnH}$

Reaction between the amide complex 4.1 and two equivalents of ${}^n\text{Bu}_3\text{SnH}$ gives a pale yellow, air sensitive oil. Characterisation of this product by NMR spectroscopy proved difficult, since the signals due to the ${}^n\text{Bu}_3\text{Sn}$ groups tend to swamp all others, particularly in the ${}^1\text{H}$ NMR spectrum where they are superimposed over the signals due to the protons of the tertiary-butyl group and the CH_2 groups of the substituent chain. The ${}^{13}\text{C}\{{}^1\text{H}\}$ NMR spectrum is slightly clearer and it is possible to see signals due to all four ${}^n\text{butyl}$ carbons, the CH_3 carbon of the ${}^t\text{butyl}$ group, the CH carbons of the cyclopentadienyl ring and some of the carbons of the backbone chain. It was concluded from the NMR data that the reaction shown in figure 4.5.9 had taken place, giving the titanium trialkyltin complex 4.7.

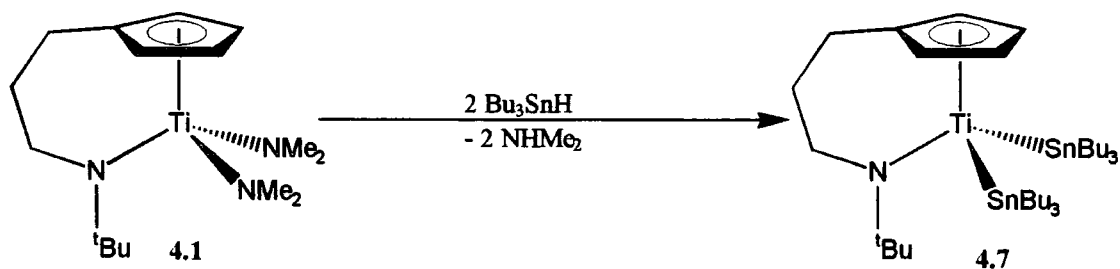

Figure 4.5.9: Reaction between 4.1 and Bu_3SnH

The use of ${}^n\text{butyl}$ as the substituent on the trialkyl tin group made characterisation of this compound difficult. The obvious solution to this difficulty would be the use of Me_3SnH instead of ${}^n\text{Bu}_3\text{SnH}$ hydride. However, due to time constraints and to the high toxicity of Me_3SnH , this was never attempted.

4.5.5: Reaction between 4.1 and phenylacetylene

In the course of early investigations² into the chemistry of homoleptic group 4 amides $M(\text{NMe}_2)_4$, it was found that all three amides ($M = \text{Ti, Zr, Hf}$) reacted with phenylacetylene liberating dimethylamine, as did the bis(cyclopentadienyl) metal amide complexes $(\text{C}_5\text{H}_5)_2M(\text{NMe}_2)_2$. However, the titanium products were found to be unstable and were never isolated, although the zirconium and hafnium compounds were isolated and characterised.

It was hoped that the presence of the intramolecularly co-ordinated amine-substituted cyclopentadienyl ligand might lead to increased stability of titanium phenylacetylene complexes derived from 4.1, allowing their isolation and characterisation. A known quantity of the titanium amide complex 4.1 was dissolved in C_6D_6 in an NMR tube with exactly two equivalents of phenylacetylene. The tube was warmed to 60°C and ^1H NMR spectra were taken at regular intervals. After a period of seven days, the ^1H NMR spectrum was still identical to that taken at the beginning of the experiment, and was consistent with an unreacted mixture of 4.1 and phenylacetylene. It is possible that use of a sealed NMR tube as the reaction vessel was hindering the reaction by preventing the escape of liberated NHMe_2 gas, but this seems unlikely since reaction still did not take place even in a Schlenk tube which was regularly evacuated to remove NHMe_2 gas. It is concluded that no reaction takes place between 4.1 and phenylacetylene under these conditions.

4.6: Reaction Between 4.1 and Aniline¹⁸

Aromatic amines such as aniline, PhNH₂, are stronger acids than aliphatic amines such as Me₂NH (pK_a C₆H₅NH₂ = 27, pK_a R₂NH = 35-40¹⁶). Hence it was expected that aniline would displace dimethylamine from the titanium amide complex 4.1 to give either a phenylamido or phenylimido species.

Compound 4.1 reacted rapidly with two stoichiometric equivalents of aniline in toluene to give, on work up, a dark brown solid, 4.8, soluble in moderately polar solvents such as CH₂Cl₂ and aromatic solvents such as toluene, and insoluble in less polar solvents such as diethyl ether and petrol. Recrystallisation from a 1:1 mixture of CH₂Cl₂ and petrol gave pure, crystalline material. The compound was studied by X-ray diffraction, infra-red and mass spectroscopy, and by extensive NMR experiments. IR spectroscopy showed a very clear N-H stretch at 3292 cm⁻¹, and other possible N-H stretches at 3400 and 3450 cm⁻¹, suggesting the presence of more than one amide or amine N-H. Mass spectra showed very little as the compound broke apart extensively under mass spectroscopy conditions. The only recognisable fragments were the substituted cyclopentadiene (EI⁺ = 179, CI⁺ = 180) and aniline (EI⁺ = 93, CI⁺ = 94). No peaks of greater mass than 179 were observed.

4.6.1: X-ray diffraction studies of 4.8

Unlike other titanium compounds derived from 2.7 studied during the course of this work, 4.8 is a solid at room temperature and block-shaped crystals suitable for X-ray diffraction were obtained fairly easily by recrystallisation from a 1:1 mixture of CH₂Cl₂ and

petrol at -30°C . X-ray diffraction, carried out by Mr P. Ford as described in appendix B, showed **4.8** to be a dimer. The asymmetric unit of **4.8** contains two independent half-molecules (designated A and B) located near to crystallographic inversion centres which generate the other half of each dimer. The two independent dimers are geometrically very similar with no significant differences in distances or angles. The structure of dimer A is shown in figure 4.6.2 together with the adopted numbering scheme. It can be seen from the X-ray structure that **4.8** is the product of the loss of both NMe_2 ligands from **4.1** as Me_2NH , together with cleavage of the Ti-N bond of the substituted cyclopentadienyl ligand as shown in figure 4.6.1, leaving the ligand co-ordinated through the cyclopentadienyl ring only. From the X-ray structure it can be seen that **4.8** contains both phenylamido (PhNH^-) and phenylimido (PhN^{2-}) ligands as well as a free tertiarybutylamine group attached to the cyclopentadienyl ring. Hence **4.8** contains free amine, singly deprotonated amine and doubly deprotonated amine groups within the same compound.

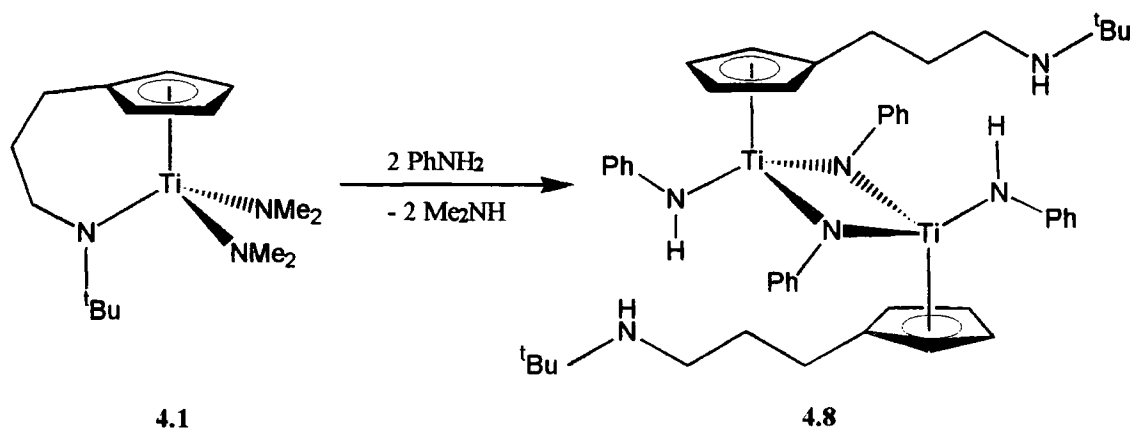

Figure 4.6.1: Reaction between **4.1** and aniline

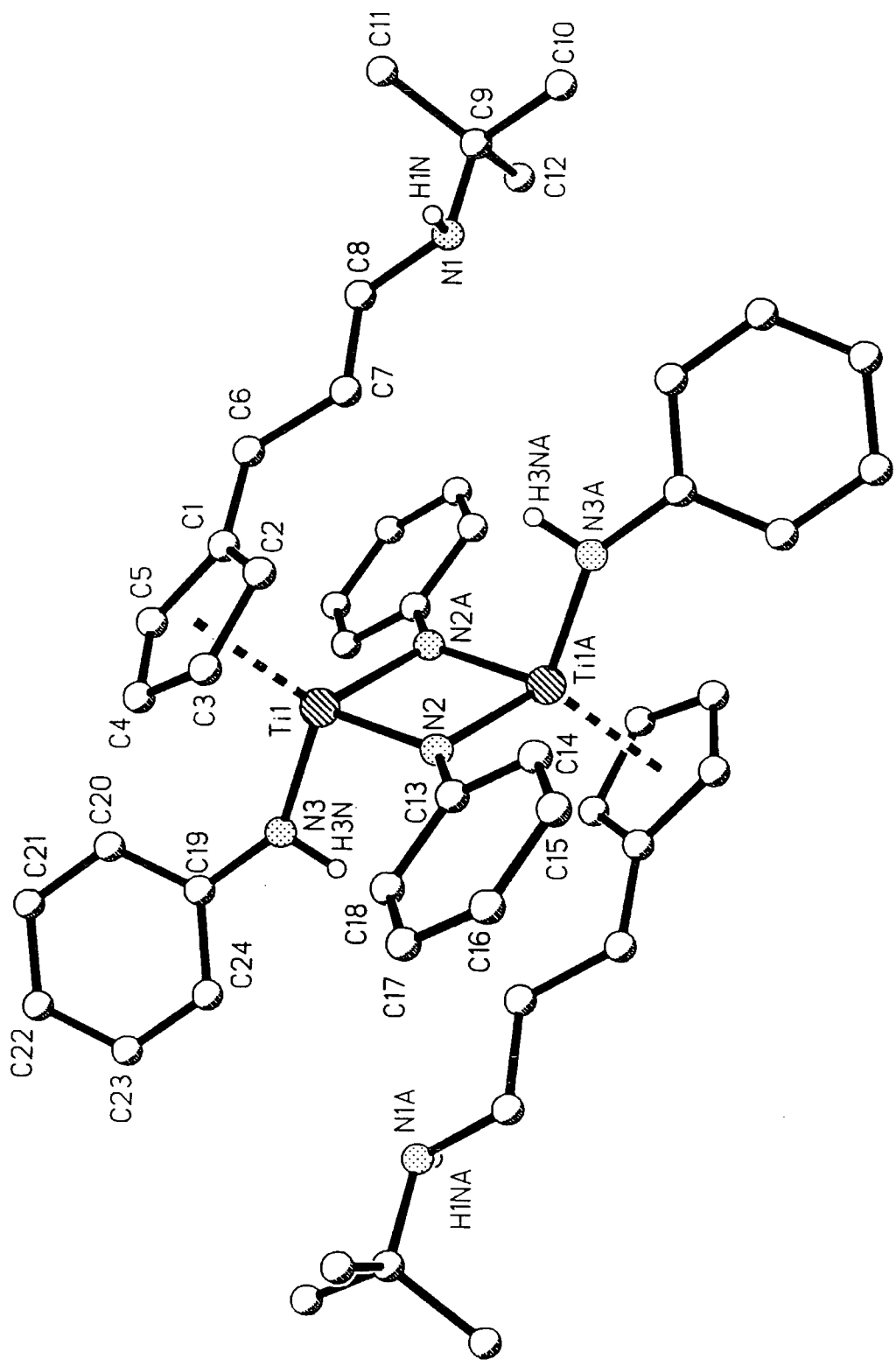

Figure 4.6.2: X-ray crystal structure of 4.8

A full list of crystallographic data for **4.8**, including tables of atomic co-ordinates, bond lengths and angles is given in appendix B. The central core of the structure of **4.8** contains two phenylimido ligands bridging two titanium metal centres, $\text{Ti}(\mu\text{-NR})_2\text{Ti}$. Within this core the Ti-NPh distances are 1.902(2)Å and 1.991(2)Å for molecule A and 1.891(2)Å and 2.008(2)Å for molecule B. The terminal Ti-NHPh distances are 1.969(2)Å and 1.967Å for A and B respectively. It can be seen that the $\text{Ti}(\mu\text{-NPh})_2\text{Ti}$ core suffers some distortion with one Ti-N distance being slightly longer than the other, the differences in length $\Delta\text{M-N}$ being 0.089Å and 0.117Å for A and B respectively. Comparison of the metal-nitrogen distances in other structures containing the $\text{M}(\mu\text{-NR})_2\text{M}$ core shows that compounds with this core fall into two classes: those which have relatively undistorted structures with $\Delta\text{M-N}$ values between 0.0 and 0.15Å; and those which have highly distorted structures with $\Delta\text{M-N}$ values between 0.36 and 0.516Å. The high degree of distortion in the second class is believed to be due to a second-order Jahn-Teller effect¹⁹ although alternative explanations have been proposed.^{20, 21} The titanium complex **4.8** falls into the first class of this type of compound, having a relatively undistorted $\text{Ti}(\mu\text{-NPh})_2\text{Ti}$ core structure. This compound is not expected to undergo Jahn-Teller distortion and the small distortion in the $\text{Ti}(\mu\text{-NPh})_2\text{Ti}$ core is more subtle in origin.

The X-ray diffraction studies show that the titanium complex **4.8** is a dimer in the solid-state and that the Ti-N bond of the intramolecularly co-ordinated amine-substituted cyclopentadiene ligand of **4.1** has been displaced by reaction with aniline. Compound **4.8** is thought to be the first complex of this type, containing as it does free amine, amide and imido groups within one complex.

4.6.2: NMR studies of 4.8

Initial characterisation of **4.8** was carried out using NMR spectroscopy, and further NMR experiments were carried out after the X-ray structure had been determined. Both ^1H and $^{13}\text{C}\{^1\text{H}\}$ NMR spectra of pure, crystalline, **4.8** in CDCl_3 were considerably more complex than expected, and it was quickly realised that two different species, **4.8a** and **4.8b**, were present, with one (**4.8a**) clearly dominating.

The 400 MHz ^1H NMR spectrum of **4.8** in CDCl_3 is shown in figure 4.6.3, with peaks assigned to the minor compound **4.8b** marked with an asterisk. The cyclopentadienyl ring of **4.8a** gives an AA'BB' spin system at 6.13 and 6.19 ppm, $^1J_{\text{A-B}} = 2.6$ Hz. A broad signal at 3.8 ppm, integrating to one proton, was assigned to N-H of a phenylamide group on the basis of selective homonuclear decoupling experiments run at 250 MHz, in which it was seen that decoupling of this peak led to some simplification of signals in the phenyl region of the spectrum. The signal at 2.38 ppm assigned to the CH_2N of the substituted cyclopentadiene was unexpectedly a quartet, $^1J_{\text{H-H}} = 7.3$ Hz (rather than a triplet), indicating apparently equal coupling to three protons. Selective decoupling of this signal caused a triplet at 0.45 ppm, $^1J_{\text{H-H}} = 7.3$ Hz (integrating to a single proton) to simplify to a singlet; and selective decoupling of the triplet at 0.45 ppm caused the quartet at 2.38 ppm due to CH_2N to simplify into a triplet. From this information it is possible to assign the triplet at 0.45 ppm to an amine N-H on the substituted cyclopentadiene. Hence it is possible to deduce by NMR that the substituted cyclopentadiene is no longer co-ordinated intramolecularly through the cyclopentadienyl ring and the amine nitrogen, but through the

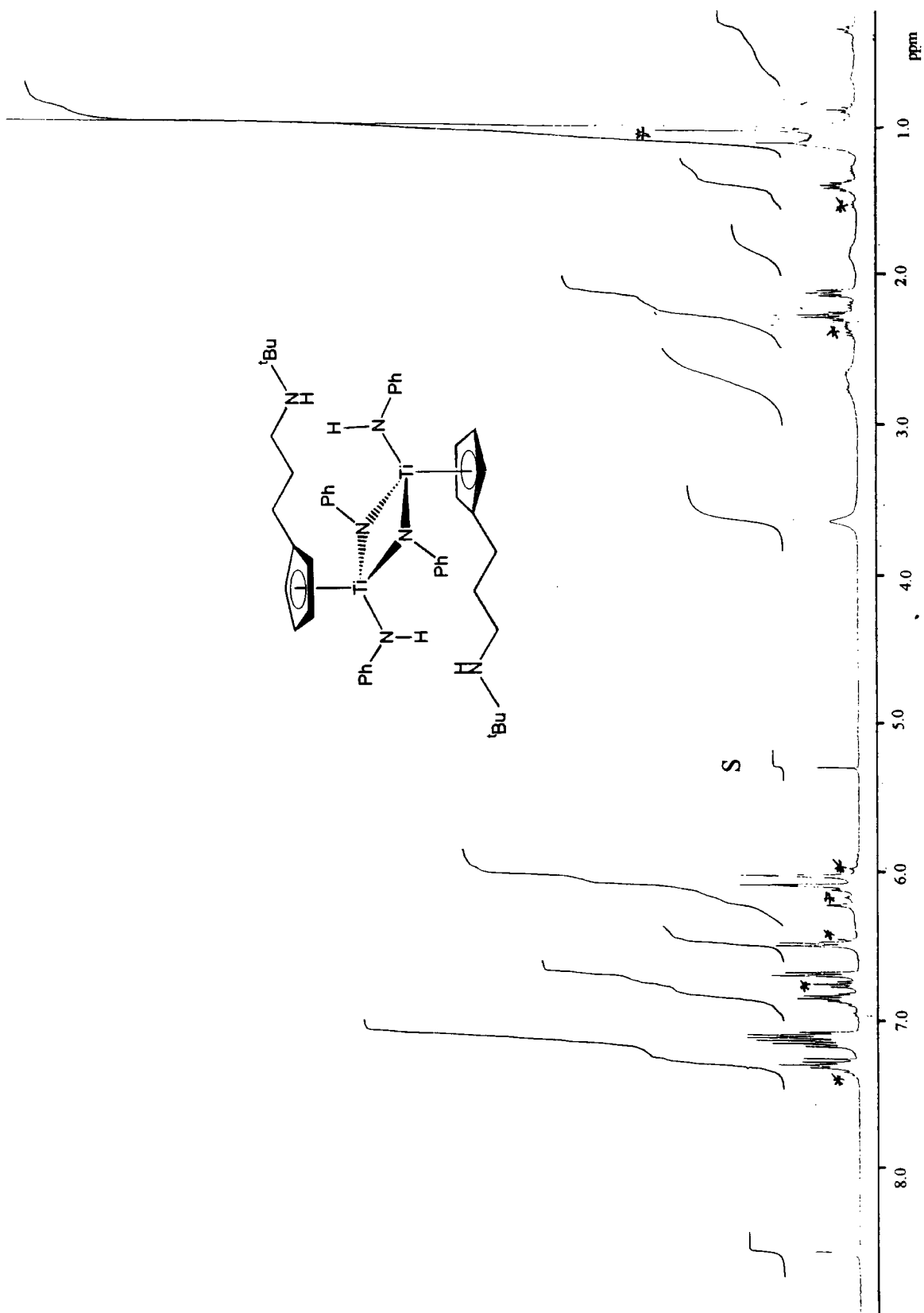

Figure 4.6.3: The ^1H NMR spectrum of 4.8 at 400 MHz in CDCl_3 (marked S), 4.8b marked *

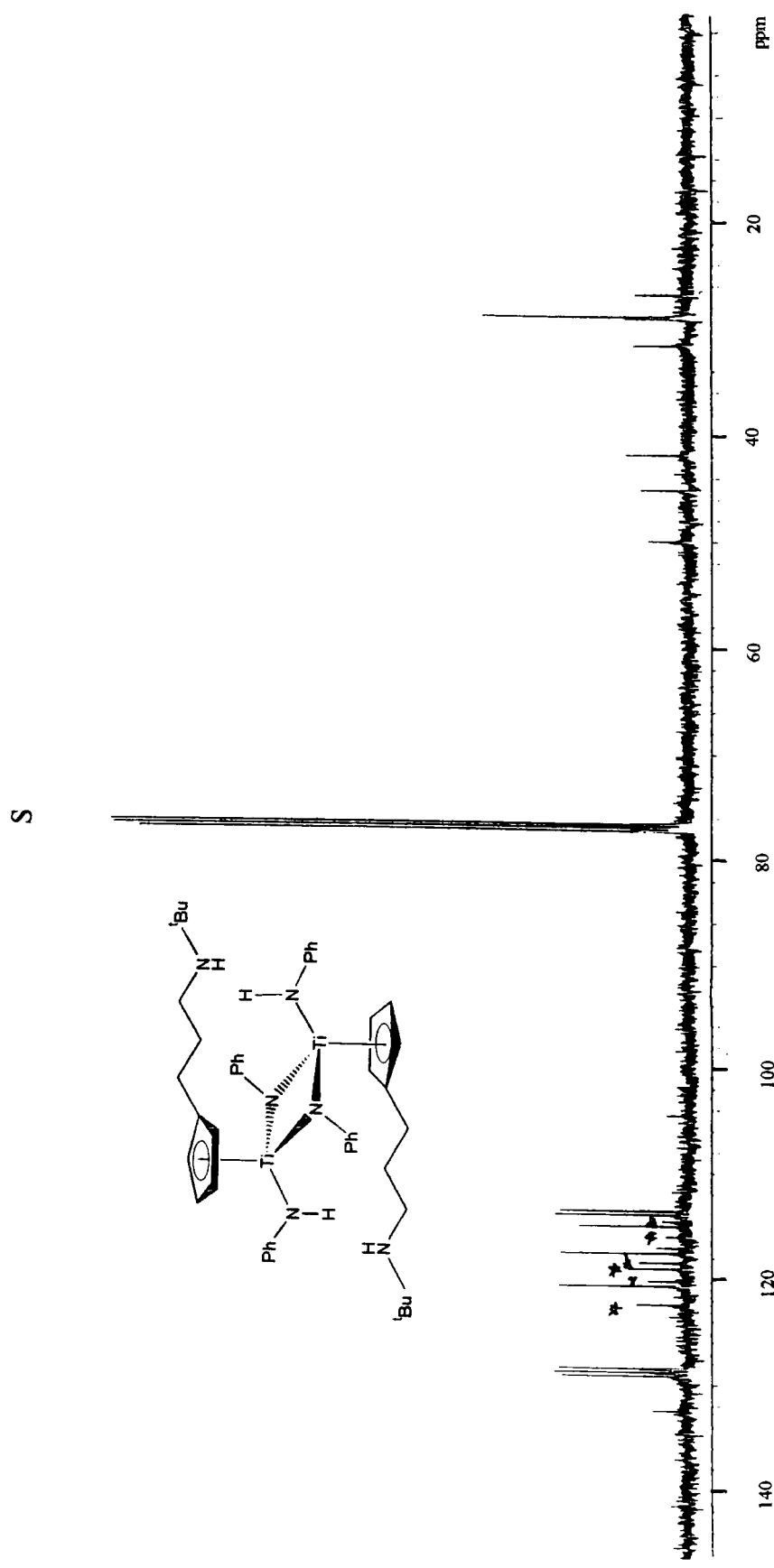

Figure 4.6.4: The 100MHz $^{13}\text{C}\{^1\text{H}\}$ NMR spectrum of 4.8 in CDCl_3 (marked S), 4.8b marked *

ring only with the amine group pendant. X-ray diffraction studies discussed in the previous section confirmed this.

The $^{13}\text{C}\{^1\text{H}\}$ NMR spectrum of **4.8** in CDCl_3 , shown in figure 4.6.4, also showed two compounds, **4.8a** and **4.8b**. It can be seen that the aromatic region of the spectrum is considerably more complex than would be expected if just one phenylamide group in one symmetry environment were present. However, only one phenylamide N-H signal could be found in the ^1H NMR spectrum, leading to speculation that the remaining signals in the phenyl region of the NMR spectra are due to a phenylimido group PhN^{2-} . Once the X-ray structure of **4.8** had been determined, it was possible to deduce that the major species **4.8a** present in the NMR spectra is the dimeric phenylimido bridged complex shown in figures 4.6.1 and 4.6.2 and which is the only species present in the solid state. Since all NMR spectra were run using samples of the same analytically pure, crystalline material used for X-ray diffraction studies, it is possible to rule out impurities as the source of the extra signals. It is believed that the dimeric species **4.8a** undergoes some dissociation in solution to give a second, monomeric species **4.8b** with the structure proposed in figure 4.6.7. Two-dimensional NMR experiments, specifically ^1H -COSY and ^1H - ^{13}C -HETCOR (shown in figures 4.6.5 and 4.6.6 respectively) confirm that two distinct species are present, and comparison of the NMR data with the X-ray structure of solid **4.8** allowed assignment of most signals due to **4.8a** and **4.8b**. The signals in the ^1H and $^{13}\text{C}\{^1\text{H}\}$ NMR spectra due to **4.8b** support the structure proposed in figure 4.6.7. In the ^1H NMR, the C-H protons of the cyclopentadienyl ring appear at 6.21 and 6.16ppm respectively. The signal at 6.16ppm is a triplet as expected for an AA'BB' system, but that at 6.21 is a quartet. It has not been possible to deduce why this is the case, but 2-dimensional NMR experiments support the

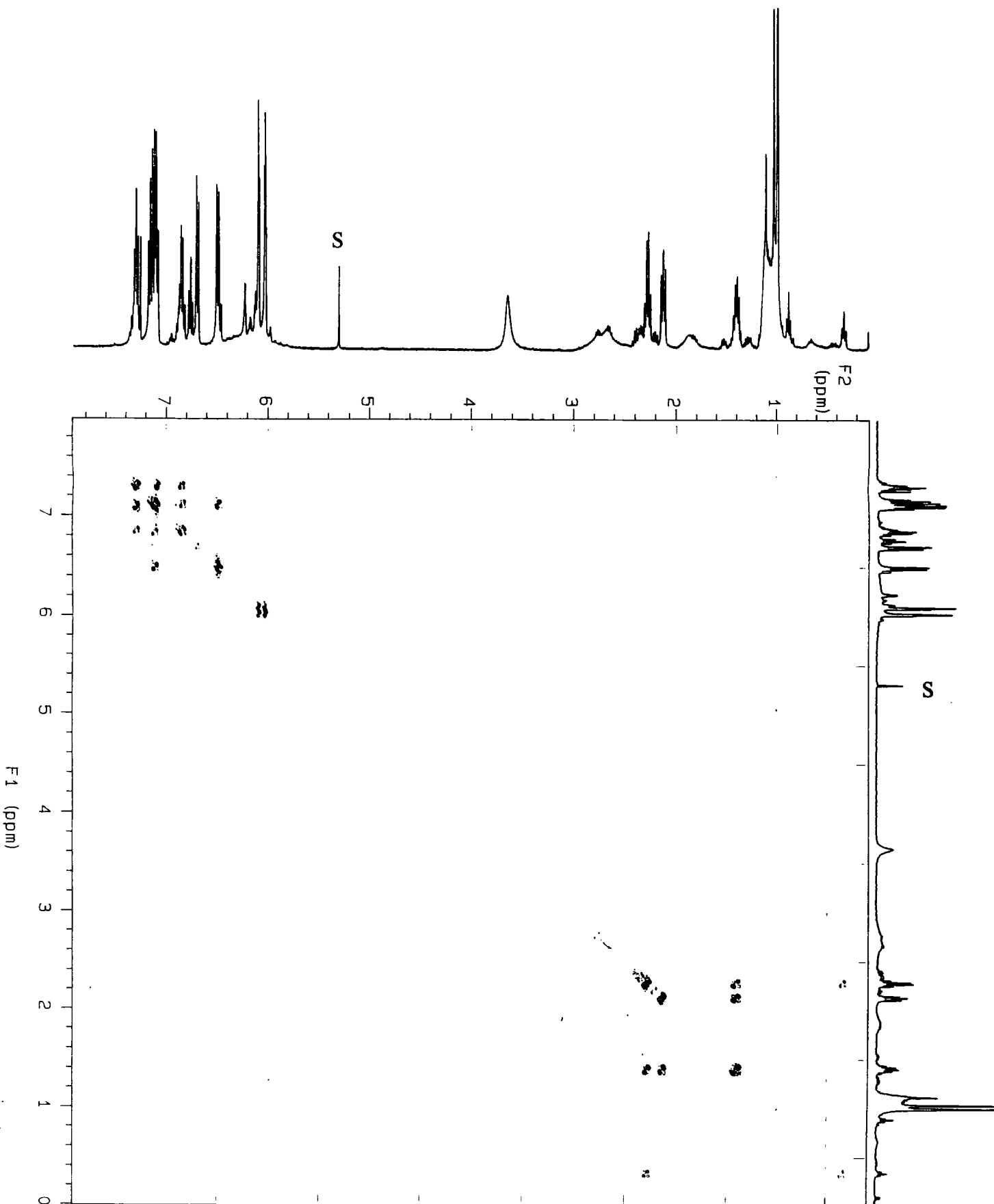

Figure 4.6.5: The ¹H COSY of 4.8 at 400MHz in CDCl₃ (marked S)

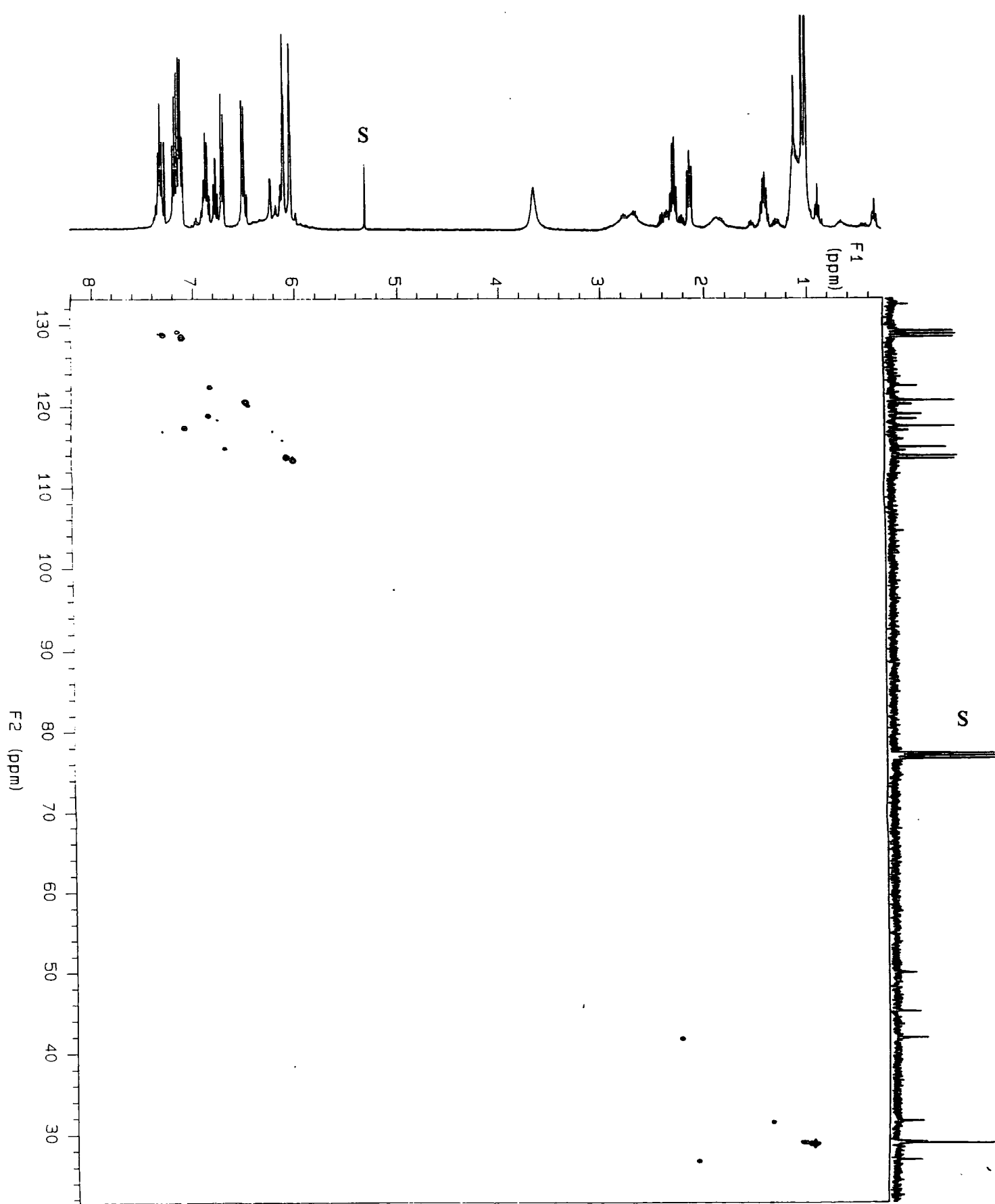

Figure 1.4.6: The ^1H - ^{13}C HETCOR of 4.8 at 400 and 100MHz in CDCl_3

assignment of these signals. The phenyl signals due to **4.8b** were to some extent swamped beneath those due to phenyl protons of **4.8a**, but careful examination of the 2-dimensional spectra allowed fairly comprehensive assignment of the phenyl ^1H and $^{13}\text{C}\{^1\text{H}\}$ signals of both **4.8a** and **4.8b**. Assignment of signals due to the protons and carbons in the substituent chain and tertiary-butyl groups of **4.8a** and **4.8b** was fairly straightforward, with the signals due to **4.8b** consistently appearing at slightly higher frequencies than the corresponding signals due to **4.8a**, as was also the case with the phenyl and cyclopentadienyl signals.

Some solid state MAS NMR studies were also carried out on **4.8** by Miss L. A. Crowe.²² The solid state ^{13}C NMR spectrum is shown in figure 4.6.8 and is consistent with the dimeric solid-state structure obtained from X-ray diffraction studies. Unfortunately it was not possible to obtain good quality, solid-state ^{15}N NMR spectra of **4.8**.

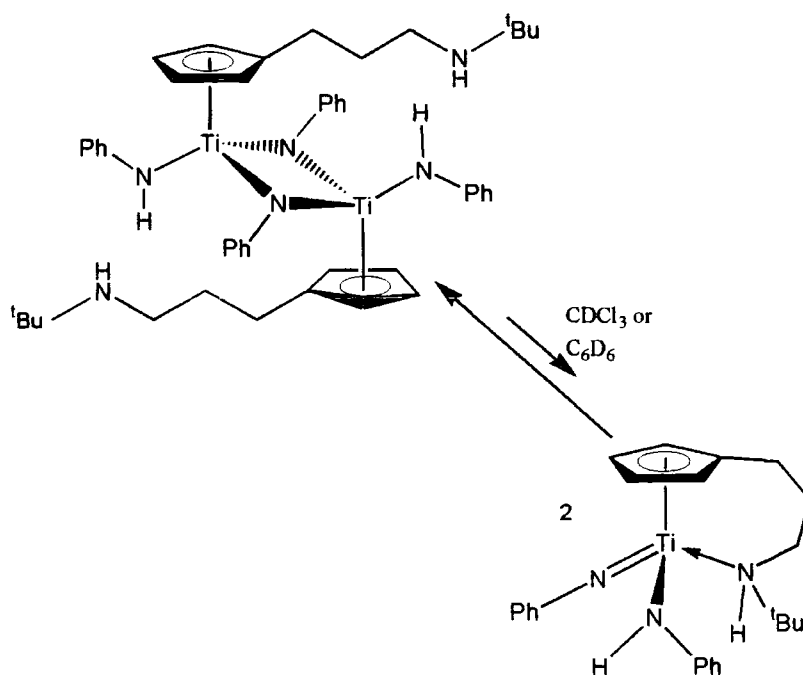

Figure 4.6.7: Proposed dissociation of **4.8** in solution

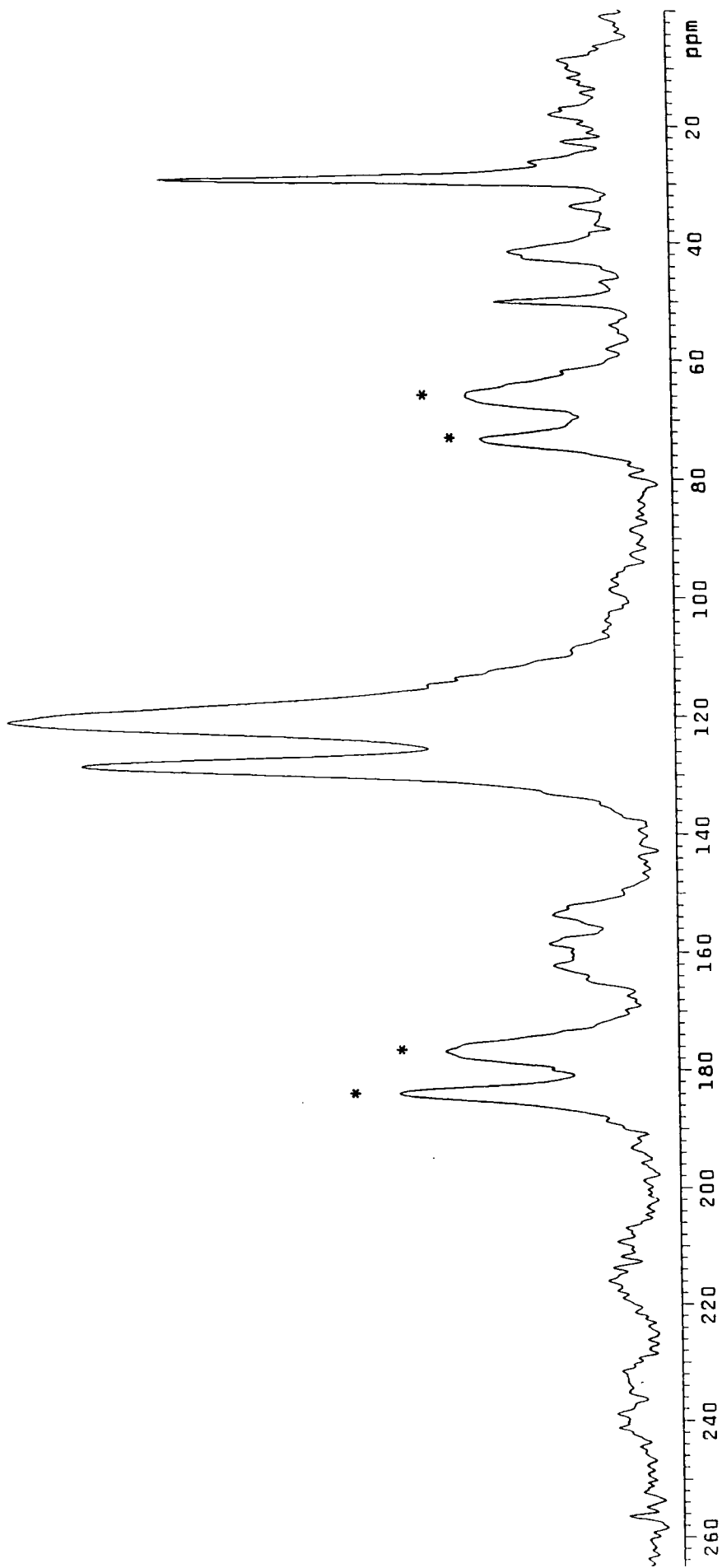

Figure 4.6.8: Solid-state ^{13}C MAS NMR spectrum of 4.8 at 75MHz, spinning side-bands marked *

4.7: Reactions Between 4.1 and Small Molecules Containing Multiple Bonds

Early transition-metal amides, including the homoleptic group 4 amides $M(NR_2)_4$ ($M = Ti, Zr, Hf$), are known to undergo insertion reactions with a variety of small molecules containing carbon-heteroatom multiple bonds, including CO_2 and CS_2 , which can insert into the metal-nitrogen bond.²² Some exploratory reactions were carried out to investigate whether the cyclopentadienyl amide complex **4.1** would react in a similar fashion.

4.7.1: Reaction between 4.1 and CO_2

A stream of CO_2 gas was bubbled through a toluene solution of **4.1** over a period of 1 hour as described in chapter 5.4.9. Reaction took place with the solution growing paler in colour. On work up a pale brown solid **4.9**, soluble in mildly polar solvents and insoluble in non-polar solvents, was isolated in low yield. Due to the low yield of this reaction it was not possible to obtain a pure sample for characterisation. From IR and 1H NMR spectra of the crude product it is possible to conclude with certainty that the compound is not **4.1**, and that a reaction has taken place. It is not, however, possible to deduce exactly what reaction has taken place. On the basis of earlier studies on $Ti(NMe_2)_4$ described in reference 4, a possible reaction is that shown in figure 4.7.1 with **4.1** reacting with excess CO_2 which inserts into the Ti-N bonds of both the $Ti-NMe_2$ ligands and the intramolecularly co-ordinated amide attached to the cyclopentadienyl ring.

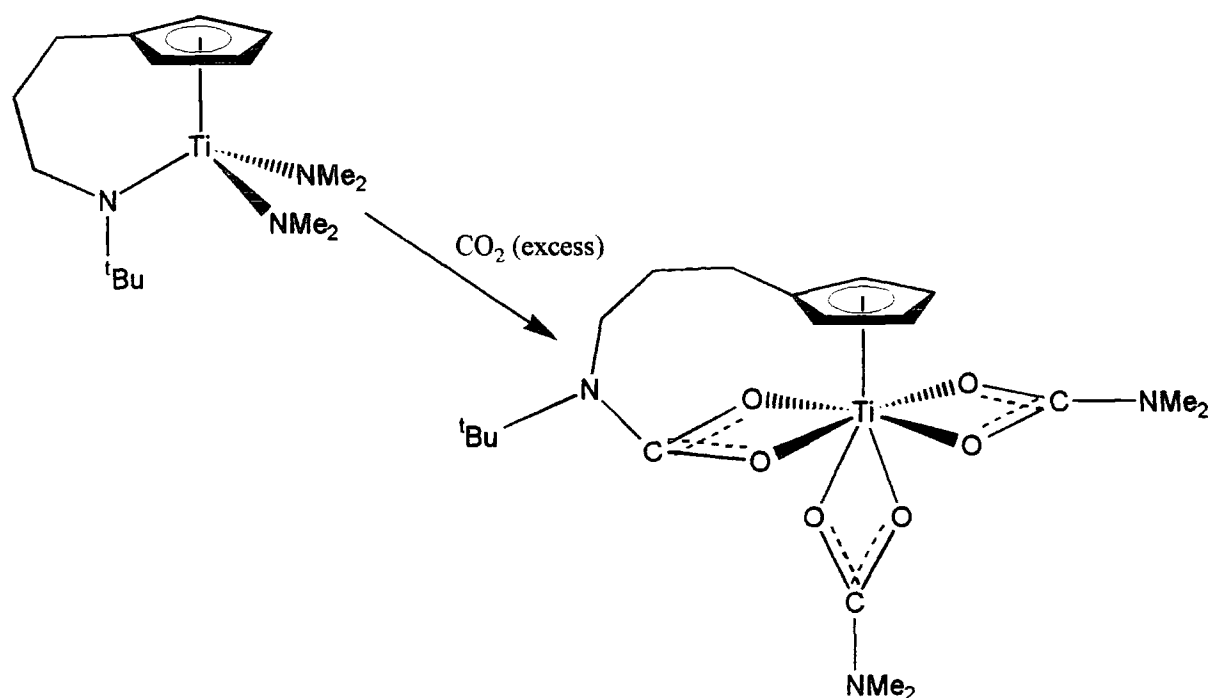

Figure 4.7.1: Possible reaction between 4.1 and CO₂

4.7.2: Reaction between 4.1 and CS₂

A toluene solution of 4.1 reacted with excess CS₂ at -78°C with the solution changing colour from brown to bright red. On allowing the solution to warm to room temperature, further reaction took place with precipitation of a bright orange solid 4.10. This precipitate was isolated and found to be air- and moisture-stable. Unfortunately it also proved to be insoluble in every solvent tried, including H₂O, DMSO and CS₂ itself. Because of its insolubility, crystals could not be grown for X-ray diffraction and solution-state NMR studies were not possible. Characterisation of this product was limited to infra-red spectroscopy, elemental analysis and solid-state MAS NMR spectroscopy, with the latter proving very informative.

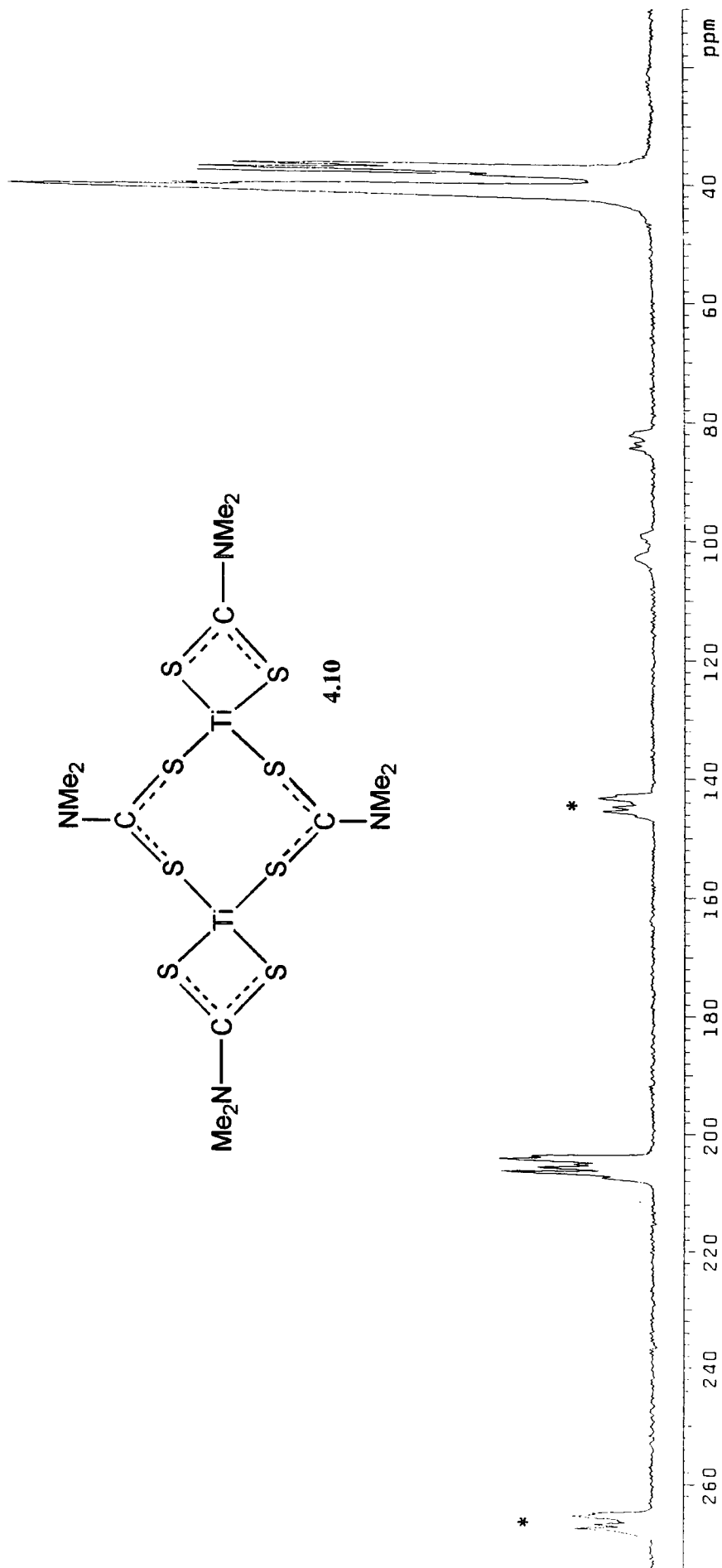

Figure 4.7.3: Solid-state $^{13}\text{C}\{^1\text{H}\}$ NMR spectrum of 4.10 at 75MHz, in CDCl_3 , spinning side-bands marked *

IR spectroscopy showed a strong absorption at 1510cm^{-1} attributed to a C-N stretch. The IR spectrum showed no N-H stretches and, more surprisingly, none of the characteristic bands caused by C-H bends of a co-ordinated cyclopentadienyl ring. Solid state $^{13}\text{C}\{^1\text{H}\}$ MAS NMR spectroscopy, run by Miss L. A. Crowe and shown in figure 4.7.2, confirmed that the substituted cyclopentadienyl ligand was no longer present in **4.10**. However, signals were present which could be attributed to CH_3 carbons, indicating that the NMe_2 groups were still present in some form. The solid-state ^{15}N MAS NMR spectrum of **4.10**, shown in figure 4.7.3, showed four sharp signals, indicating that nitrogen is present in four different symmetry environments. It is unusual for a solid-state ^{15}N spectrum to be so sharp and well defined, since signals are usually very broad.

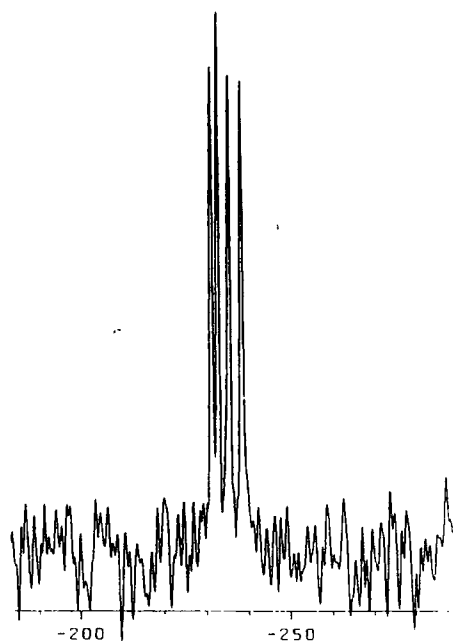

Figure 4.7.3: Solid-state ^{15}N MAS NMR spectrum of **4.10**

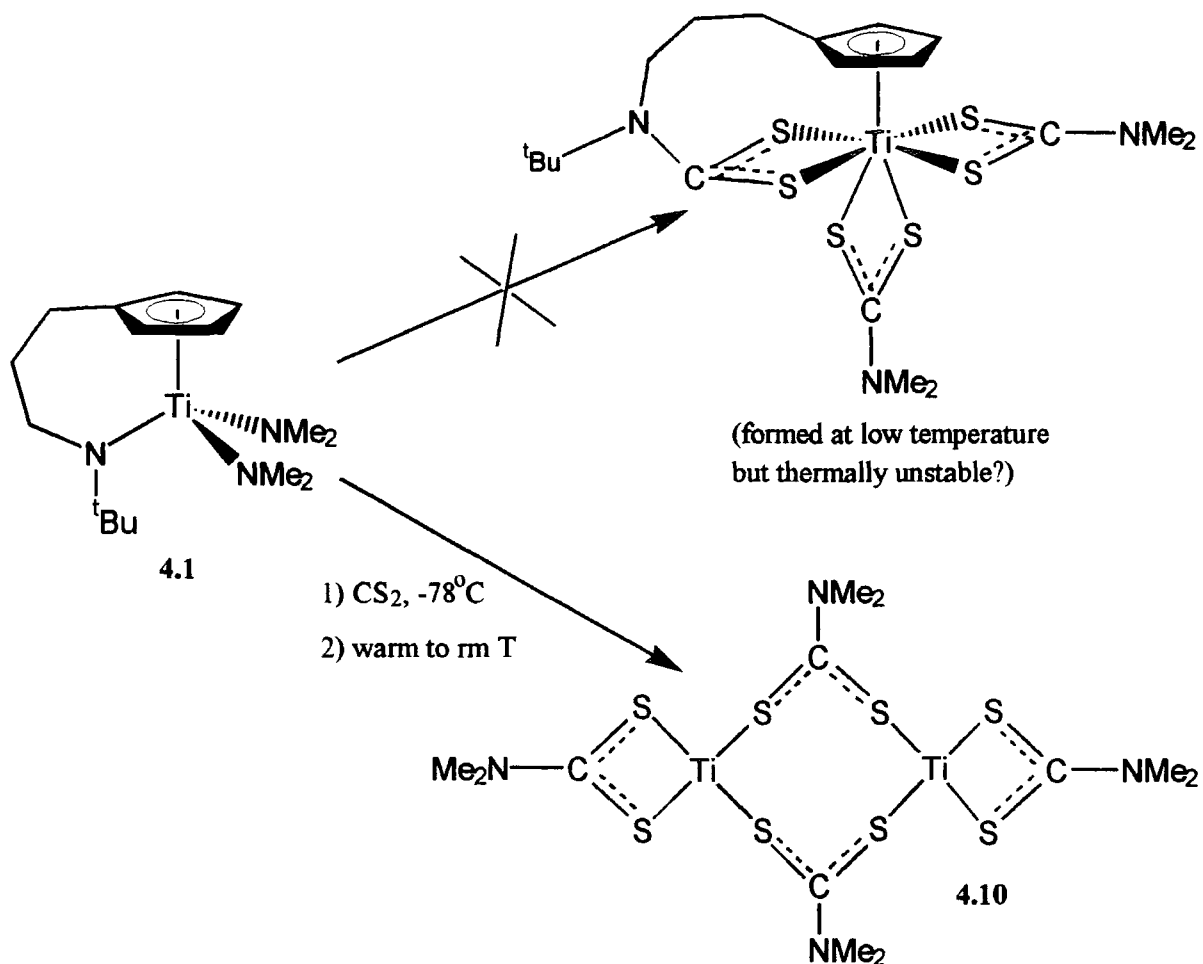

Figure 4.7.4: Proposed reaction between 4.1 and CS₂

It is concluded that CS₂ completely displaces the substituted cyclopentadienyl ligand from 4.1 and probably inserts into the Ti-N bonds of the Ti-NMe₂ ligands to give some form of dithiocarbamate complex. One possibility for the structure of 4.10 is the bridged dimeric titanium dithiocarbamate complex shown in figure 4.7.4. Depending on the conformation of the molecule in the solid-state, this structure is consistent with the NMR data. Elemental analysis also lends some support to this structure. It has not been possible to deduce what happens to the substituted cyclopentadienyl ligand in this reaction, since work-up of the

filtrate, after the precipitate of **4.10** had been removed, yielded a complex, air-sensitive mixture of products, the only identifiable one of which was a trace of unreacted **4.1**. From observing changes in appearance as the reaction mixture was allowed to warm from -78°C to room temperature, it is proposed that reaction between **4.1** and CS_2 takes place in two stages, with initial formation of a thermally unstable species which has not yet been isolated or characterised. It is possible that this species could be the complex formed by insertion of CS_2 into all the amide Ti-N bonds of **4.1** and which then re-arranges on heating to give **4.10**.

4.7.3: Other attempted reactions

According to the literature, a wide variety of other small molecules containing carbon-heteroatom multiple bonds will insert into the M-N bonds of homoleptic early transition-metal amides, including CH_3CN , DMSO and small ketones. Reactions were attempted between **4.1** and CH_3CN , DMSO and acetylacetone but failed to yield any characterisable products. Since reactions between **4.1** and CO_2 or CS_2 also failed to yield the expected products it is concluded that although **4.1** behaves very much like $\text{Ti}(\text{NMe}_2)_4$ in its reactions with weak acids, it differs significantly in its reactivity towards small, multiply bonded molecules.

4.8: Conclusions

It can be seen from the work described in this chapter that the aminolysis reactions between the substituted cyclopentadienyl and indenyl ligands **2.7** and **2.8** and homoleptic group 4 amides, $M(NMe_2)_4$, represent the simplest and most efficient route into group 4 complexes of these ligands. Although attempts to convert the amide complexes **4.1** and **4.2** into halides failed, it was realised that these complexes are themselves versatile starting materials for a wide variety of new compounds by their reactions with weak acids. The reaction between **4.1** and aniline led to the formation of an interesting and unusual phenylimido-bridged dimer **4.7**. Reactions between **4.1** and small, multiply-bonded molecules failed to give the expected products, leading to the conclusion that while the reactivity of **4.1** towards weak acids is similar to that of $Ti(NMe_2)_4$, its reactivity towards small, multiply bonded molecules is very different.

4.9: References for Chapter 4

- 1) A. K. Hughes, A. Meetsma and J. H. Teuben, *Organometallics*, 1993, **12**, 1936.
- 2) G. Chandra and M. F. Lappert, *J. Chem. Soc. A*, 1968, 1940.
- 3) D. E. Bowne and R. F. Jordan, *Organometallics*, 1995, **14**, 3630.
- 4) G. M. Diamond, S. Rodewald and R. F. Jordan, *Organometallics*, 1995, **14**, 5.
- 5) (a) G. M. Diamond, R. F. Jordan and J. L. Petersen, *J. Am. Chem. Soc.*, 1996, **118**, 8024;
(b) G. M. Diamond, R. F. Jordan and J. L. Petersen, *Organometallics*, 1996, **15**, 4030.
- 6) G. M. Diamond, R. F. Jordan and J. L. Petersen, *Organometallics*, 1996, **15**, 4045.
- 7) G. M. Diamond, R. F. Jordan and J. L. Petersen, *Organometallics*, 1996, **15**, 4038.
- 8) Y. Mu, W. E. Piers, D. C. Macquarrie, M. J. Zaworotko, *Canad. J. Chem.*, 1996, **74**, 1696.
- 9) W. A. Hermann and W. Baratta, *J. Organomet. Chem.*, 1996, **506**, 357.
- 10) W. A. Hermann, W. Baratta and M. J. A. Moriewietz, *J. Organomet. Chem.*, 1995, **497**, C4.
- 11) D. C. Bradley and I. M. Thomas, *Proc. Chem. Soc.*, 1959, 225; *J. Chem. Soc.*, 1960, 3857.
- 12) G. M. Diamond, S. Rodewald and R. F. Jordan, *Organometallics*, 1995, **14**, 5.
- 13) NMR spectrum of $\text{Ti}(\text{NMe}_2)_4$, prepared as described in reference 12 and run at 250MHz in CDCl_3
- 14) (a) K. E. du Plooy, U. Moll, S. Wocaldo, W. Massa and J. Okuda, *Organometallics*, 1995, **14**, 3129; (b) J. Okuda, *Chem. Ber.*, 1990, **123**, 1649.
- 15) (a) J. C. Flores, J. C. W. Chien and M. D. Rausch, *Organometallics*, 1994, **13**, 4140; (b) G. Trouvé, D. A. Laske, A. Meetsma and J. H. Teuben, *J. Organomet. Chem.*, 1996, **511**, 255.
- 16) S. H. Pine, J. B. Hendrickson, D. J. Cram and G. S. Hammonds, "*Organic Chemistry*",

4th edition, McGraw-Hill (Singapore), 1985, p200.

17) J. L. Wardell, *Comprehensive Organometallic Chemistry I*, G. Wilkinson, F. G. A. Stone and E. W. Abel (eds), Pergamon Press (Oxford), 1982, **1**, 54.

18) A. K. Hughes, S. M. B. Marsh, J. A. K. Howard and P. S. Ford, *J. Organomet. Chem.*, in press.

19) D. L. Thorn, W. A. Nugent and R. L. Harlow, *J. Am. Chem. Soc.*, 1981, **103**, 357.

20) M. H. Chisholm, K. Folting, J. C. Huffman and A. L. Ratermann, *Inorg. Chem.*, 1982, **21**, 978.

21) B. R. Ashcroft, A. J. Nielson, D. C. Bradley, R. J. Errington, M. B. Hursthouse and R. L. Short, *J. Chem. Soc., Dalton Trans.*, 1987, 2059.

22) M. H. Chisholm and M. W. Extine, *J. Am. Chem. Soc.*, 1977, **99**, 782.

23) L. A. Crowe, Undergraduate Research Project, University of Durham, March 1996.

CHAPTER 5

Experimental

5.1: General Information and Preparation of Starting Materials

Unless otherwise stated, all reactions were carried out under an atmosphere of dry nitrogen (BOC) using standard Schlenk-line and glove-box techniques. Glove-box work was carried out in a Braun Labstar 50 glove-box.

Solvents were pre-dried by storing over 3Å molecular sieves (Lancaster) before refluxing over the appropriate drying agent under nitrogen for 6 hours, collecting and storing in dry 500ml Young's ampoules. Degassing of all solvents except toluene was carried out by the freeze-thaw method. Toluene was de-oxygenated by bubbling nitrogen through the dry solvent for 15 minutes using a dry canula. Drying agents used were sodium lumps (toluene), lithium aluminium hydride (diethyl ether), potassium (THF, hexane), sodium benzophenone (THF) and calcium hydride (acetonitrile, dichloromethane). NMR solvents were stored in 50ml Young's ampoules over 3Å molecular sieves (CDCl_3 , C_6D_6) or calcium hydride (CD_3CN), degassed by freeze-thaw and manipulated by vacuum transfer. Grignard reagents, where necessary, were standardised by titration against n-propanol using 1,10-phenanthroline as an indicator to determine the exact concentration.¹

Solution state NMR spectra were run in CDCl_3 , C_6D_6 or CD_3CN on a Varian XL-200 (^1H at 200MHz), Brüker AC-250 (^1H at 250.13MHz, ^{13}C at 62.9MHz, ^{19}F at 235.36MHz and ^{31}P at 101.2MHz) or Varian VXR-400 (^1H at 400MHz, ^{13}C at 100MHz) NMR spectrometer. Solid-state NMR spectra were run on a Varian VXR-300 solid-state NMR spectrometer. Infra-red spectra were run as thin films on KBr plates (liquids) or as KBr discs (solids) on a Perkin-Elmer 1615 FTIR spectrometer. Solid-state magnetic susceptibilities were measured on a Johnson-Matthey-Evans balance and solution state magnetic susceptibilities were measured on a Brüker AC-250 NMR spectrometer and

calculated using Evans' method.² These procedures are described in detail in appendix A. Mass spectra and micro-analysis were carried out in-house at the University of Durham. X-ray structures were determined as described in appendix B. Starting materials were used as received except where otherwise stated. ⁿBuLi was purchased as an approximately 1.6M solution in hexanes (Aldrich) and was titrated on receipt by Mr B. Hall to determine the exact molarity.

5.1.1: Lithium Dimethylamide

Pure, dry dimethylamine (approx. 0.5 mol) was produced by dripping 80ml of 40% aqueous dimethylamine solution onto sodium hydroxide pellets (60g) under vacuum and condensing the liberated gas into a Young's ampoule cooled to -78°C on a vacuum line as shown in figure 5.1.1. Throughout this procedure the pressure of gas in the vacuum line was carefully monitored using a mercury manometer, and addition of the aqueous Me₂NH solution to the NaOH pellets was carried out at such a rate that the pressure did not exceed 150mmHg. The dimethylamine was vacuum transferred into a 3L 3-necked flask fitted with a reflux condenser and containing toluene or THF (500ml of sodium wire dried). The solution was allowed to warm to 0°C under nitrogen and ⁿbutyl lithium (280ml of 1.62M in hexane, 0.5mol) was added dropwise over 2 hours. The pale cream suspension of Li(NMe₂) was allowed to warm to room temperature and stirred overnight with the flask vented through a mercury bubbler before being used without further purification in the preparation of M(NMe₂)₄ (M = Ti, Zr).

5.1.2: $\text{Ti}(\text{NMe}_2)_4$

This compound was prepared according to the method of Diamond and Jordan.³ A toluene solution of $\text{Li}(\text{NMe}_2)$ (0.5 mol, prepared using the procedure in section 5.1.1) was cooled to 0°C and TiCl_4 (19 g, 0.1 mol) was added dropwise. After stirring overnight, the solvent was removed under reduced pressure. The residue was extracted with dry, degassed light petroleum (4 x 100 ml of b.pt. $40\text{--}60^\circ\text{C}$). The extracts were filtered through celite using a 4 cm diameter, medium porosity glass frit and the solvent removed under reduced pressure to give a brown oil which was distilled (b.pt. 59°C at 0.8 mmHg) to give a highly air-sensitive yellow oil. Obtained 17 g, 76% yield with respect to TiCl_4 .

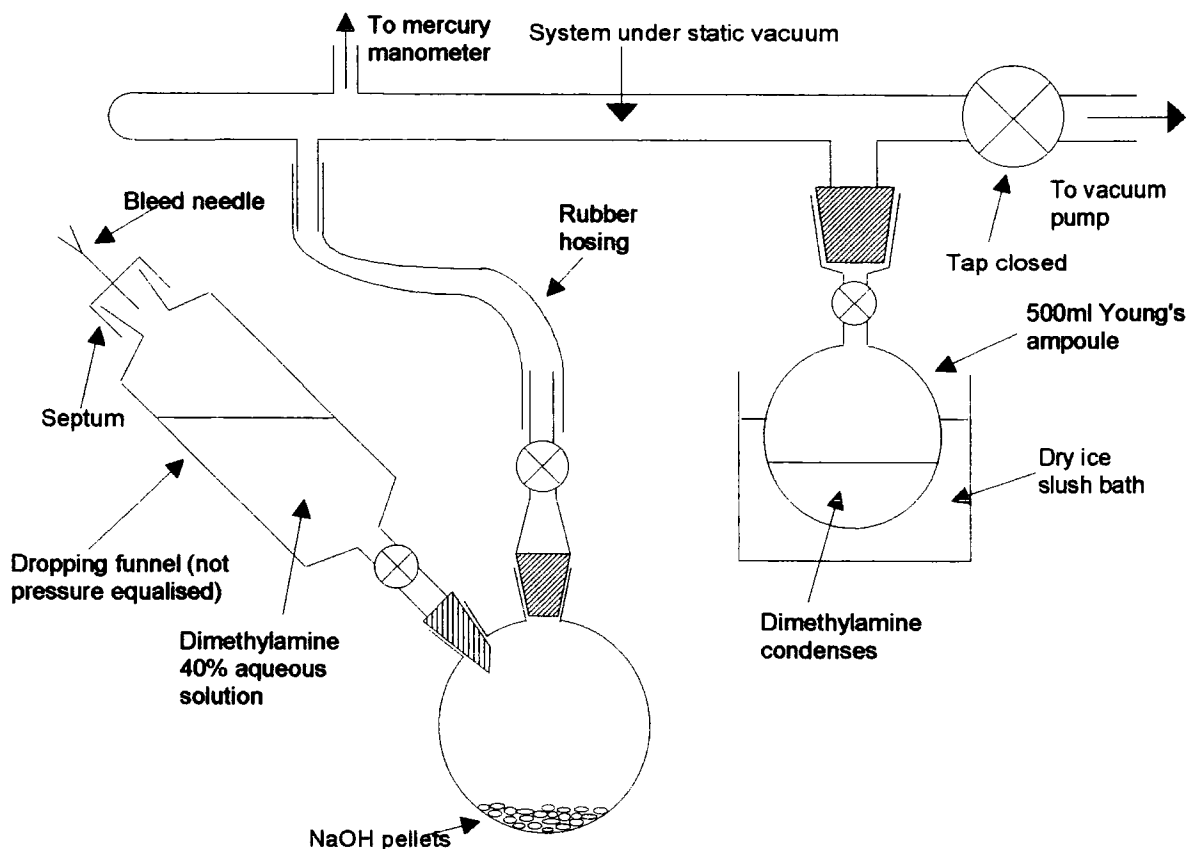

Figure 5.1.1: Apparatus for liberating free Me_2NH from an aqueous solution.

5.1.3: $\text{ZrCl}_4(\text{THF})_2$

ZrCl_4 (30g, 0.13mol) was dissolved in dry, degassed CH_2Cl_2 in a large Schlenk tube. The solution was cooled to 0°C and THF (50ml) was added dropwise, causing a rapid, exothermic reaction with formation of a white precipitate. After warming to room temperature and stirring for 1 hour, hexane (50ml) was added to ensure complete precipitation of the product, which was filtered, washed (2 x 20ml hexane) and dried under reduced pressure to give $\text{ZrCl}_4(\text{THF})_2$ as a white, micro-crystalline powder. Obtained 41g, 84% yield with respect to ZrCl_4 .

5.1.4: $\text{Zr}(\text{NMe}_2)_4$

This compound was prepared according to the method of Bradley and Thomas.⁴ $\text{Li}(\text{NMe}_2)$ (0.5mol) was prepared as a THF solution using the procedure described in 5.1.1. $\text{ZrCl}_4(\text{THF})_2$ (38g, 0.1mol) was added in 1g portions from taped sample-vials prepared in a glovebox. After stirring overnight the mixture was refluxed for 2 hours before both liquid and solid phases of the reaction mixture were decanted into a large Schlenk tube *via* a wide-bore canula. The solvent was removed under reduced pressure and the resultant white solid (consisting of the desired product and LiCl) was transferred to the sublimation apparatus shown in figure 5.1.2. It is possible to filter the liquid away from the solid at this stage, but the process is time-consuming and removal of the solvent from the filtrate gives crude $\text{Zr}(\text{NMe}_2)_4$ as a sticky solid which was extremely difficult to manipulate. The presence of lithium chloride on the other hand gives a dry, free-flowing powder which is easily transferred to the sublimation apparatus using addition tubes or a glovebox. The product was sublimed away from the LiCl (60°C at 0.01mmHg) and formed as white, highly air-

sensitive crystals on the sides of the sublimator. Obtained 7g, 26% yield with respect to $\text{ZrCl}_4(\text{THF})_2$. This yield is considerably lower than the 59% yield reported in the literature.⁴ Use of ZrCl_4 as a starting material and toluene as the solvent according to the method of Diamond and Jordan gave an even lower yield of 12%, compared with a literature yield of 83%.³ It is not known why the yields were so low, and various modifications to temperature, reaction time, solvent and work-up procedure failed to improve this yield.

5.1.5: Sodium Cyclopentadienide

Sodium lumps (9g, 0.39mmol) were carefully cut into small pieces and placed in a nitrogen purged 1L flask containing THF (300ml, not dried) which had been degassed by one freeze thaw cycle. The flask was stirred until all evolution of hydrogen (from reaction between sodium metal and any moisture present in the solvent) had ceased (monitored using a silicone-oil bubbler). Freshly cracked cyclopentadiene (23g, 0.35mol) was added dropwise, evolving hydrogen. The mixture was stirred overnight and the pink solution of sodium cyclopentadienide was filtered and either used directly for reaction or stored in a dry Young's ampoule as an approximately 1.16M solution in THF.

5.1.6: Lithium Indenide

Indene (8.7g, 75mmol) was dissolved in dry, degassed hexane in a large Schlenk tube. The solution was cooled to 0°C. n-Butyl lithium (46ml of 1.62M in hexane, 75mmol) was added dropwise over a period of two hours with the Schlenk open to a mercury bubbler. After warming to room temperature and stirring overnight, the white precipitate of lithium indenide was filtered by canula, washed with hexane (2 x 50ml) and dried under

reduced pressure to give lithium indenide as a free-flowing, highly air-sensitive powder which was stored in a glove-box until required. Obtained 9.1g, 99% yield with respect to indene.

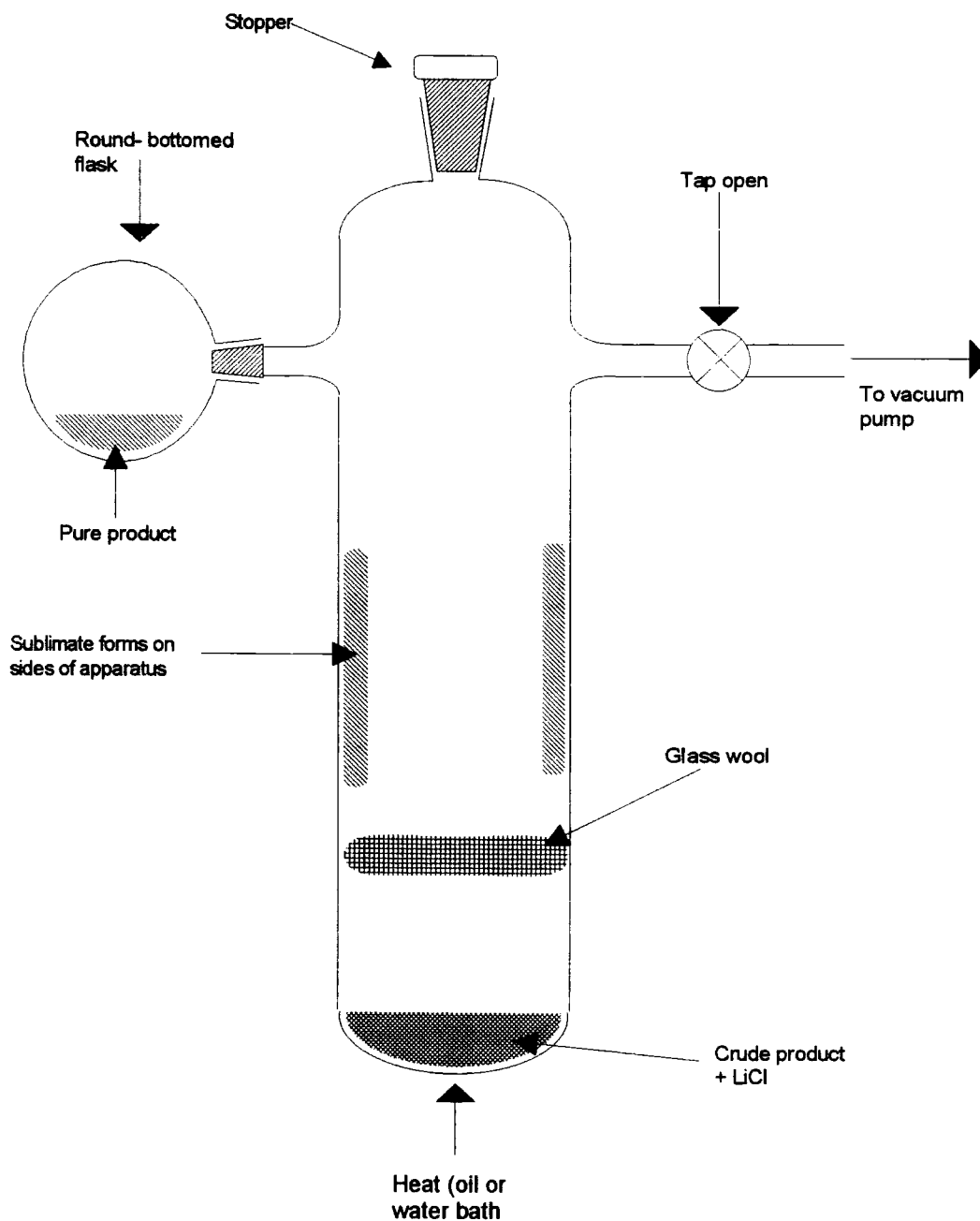
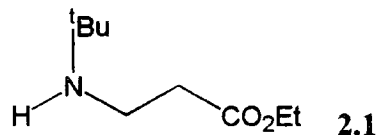

Figure 5.1.2: Apparatus for the sublimation of $Zr(NMe_2)_4$

5.2 Experimental for Chapter 2

5.2.1 Synthesis of 2.1⁵



In a typical reaction, ethyl acrylate (50g, 0.5 mol) was added to a stirred solution of tertiarybutyl amine (40g, 0.6 mol) in ethanol (50ml) at room temperature in a fume hood. The mixture was stirred in air for 48 hours, after which the ethanol was removed under reduced pressure to give a colourless oil which was shown by NMR to be the desired product **2.1**, sufficiently pure for further reactions. **2.1** can be further purified by distillation at reduced pressure (b.p. 90°C at 18mm Hg; literature 90-92°C at 20mmHg). Obtained 89g, 98% yield.

5.2.2: Synthesis of 2.2⁵

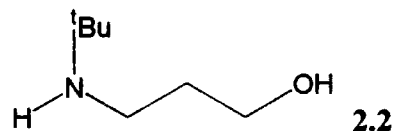

A 3-litre, 3-necked flask was fitted with a reflux condenser and a pressure-equalised dropping funnel. LiAlH₄ (16g, 0.42 mol) was loaded into the flask, which was purged with nitrogen through the condenser. Diethyl ether (1L, not dried or degassed) was added and the suspension stirred until evolution of gas ceased (approximately 10 minutes). The suspension was cooled to 0°C and **2.1** (87g, 0.50 mol) was added dropwise over a period of 4 hours. The mixture was allowed to warm to room temperature and was stirred overnight under a slow nitrogen purge before refluxing for 2 hours to ensure complete reaction. The contents of the flask were slowly added to excess ice cold concentrated aqueous sodium hydroxide solution with rapid stirring and cooling. Sufficient sodium hydroxide was used to

make the aqueous layer strongly alkaline and to dissolve most of the solid (approx. 25g NaOH in 150ml water). When reaction had ceased, the ether layer was decanted off and the aqueous layer extracted with further portions of ether (4 x 100ml). The combined ether extracts were dried over MgSO₄ and filtered before the solvent was removed on a rotary evaporator to give a white, crystalline solid **2.2**. This was shown by NMR and elemental analysis to require no further purification. Obtained 48g, 72% yield.

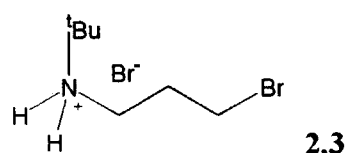

5.2.3: Synthesis of 2.3⁶

CAUTION: **2.3** and analogous compounds such as **2.4** and **2.5** are potentially nitrogen mustards and should be handled at all times in a fume hood using the appropriate protective clothing.

2.2 (10.3g, 80mmol) was loaded into a 250ml round bottom flask fitted with a septum seal and a reflux condenser. The flask was cooled to 0°C and HBr (60ml of 48% aqueous solution) was added directly to the rapidly stirred solid over a period of 1 hour. After stirring at room temperature overnight, the mixture was refluxed vigorously for 1 hour. The condenser was altered to form a distillation apparatus, and as much water as possible was distilled off at atmospheric pressure. The mixture was refluxed for a further hour before the remaining volatiles were distilled off (b.pt. 180°C). **N.B.** Cold traps and receivers from the distillations must be handled with extreme caution after this experiment as they contain high concentrations of HBr.

The sticky solid residue was extracted in the minimum quantity of hot acetonitrile and filtered rapidly through a hot gravity filtration apparatus. The filtrate was cooled in

stages to -30°C to give very pale brown, needle-like crystals of **2.3** which were filtered, washed in diethyl ether (3 x 50ml) and dried under reduced pressure. A further crop of crystals was obtained by adding an equal amount of diethyl ether to the filtrate and re-cooling to -30°C . Product obtained by this method was analytically pure. Obtained 12.7g, 60% yield with respect to **2.2**.

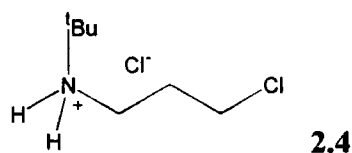

5.2.4: Synthesis of **2.4**⁷

A 1-litre, 2-necked flask was fitted with a reflux condenser and charged with **2.2** (48g, 0.37 mol). CH_2Cl_2 was added to form a slurry which was cooled to 0°C in a fume hood. A few drops of concentrated HCl (1ml of $\sim 10\text{M}$ aqueous solution) were added to the rapidly stirred slurry to ensure protonation of the amine. Thionyl chloride (50g, 0.42mol) was added dropwise by syringe, causing evolution of heat and white fumes. The mixture was stirred overnight before the dichloromethane was removed under reduced pressure to leave a dirty white solid. This was refluxed in ethanol (200ml) for two hours to decompose any unreacted thionyl chloride which might be present. On cooling the resulting ethanol solution, white solid **2.4** appeared which was filtered, washed with ether and dried under reduced pressure. Recrystallisation from the minimum quantity of hot acetonitrile yielded white, needle like crystals of analytically pure, anhydrous **2.4**. Obtained 51g, 74% yield with respect to **2.2**.

5.2.5: Synthesis of 2.7

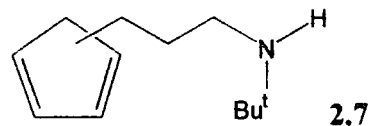

A solution of **2.4** (30g, 0.16mol) in dry THF (150ml) was cooled to 0°C in a nitrogen purged 1L flask fitted with a reflux condenser. Sodium cyclopentadienide (freshly prepared from sodium (9g, 0.39 mol) and cyclopentadiene (23g, 0.35mol) as described in **5.1.5**) was added dropwise to the rapidly stirred solution. The solution turned pink in colour and a fine white precipitate appeared. After refluxing for 4 hours water (100ml) was added. The mixture separated into a pale brown aqueous layer and a dark organic layer. Occasionally the water-THF mixture formed an emulsion and a small quantity of saturated aqueous MgSO₄ solution was added to separate the layers. The organic layer was decanted and the aqueous layer extracted with ether (2x100ml) and petrol (1x100ml, b.pt. 40-60°C). The combined organic extracts were dried over MgSO₄ and filtered before the solvent was removed on a rotary evaporator to give crude **2.7** as a brown, free flowing oil. On standing overnight, a small quantity of white, needle-like crystals appeared. These were filtered and shown by NMR to be N-tertiarybutyl azetidine **2.6** formed by ring closure of free N-^tbutyl-3-chloropropylamine **2.5** (see section 2.8). The remaining brown oil was shown by ¹H and ¹³C NMR and GC-MS to be a mixture of all three isomers of the desired product **2.7** along with some C₅H₆ and C₁₀H₁₂ impurity.

The oil was taken up into petrol (100ml, b.pt. 40-60°C), and dilute aqueous HCl (30mls of ~1M solution) was added. The organic layer was decanted off, and the aqueous layer extracted with further portions of petrol (1 x 50ml, b.pt. 40-60°C) and diethyl ether (2 x 50ml). The organic extracts were discarded. Diethyl ether (100ml) was added to the aqueous layer which was then treated with aqueous NaOH solution (40ml of ~1M added

dropwise) until alkaline. The ether was decanted off and the aqueous layer extracted further (2 x 50ml ether, 1 x 50ml petrol). The combined organic extracts were dried over MgSO₄ before the volatiles were removed on a rotary evaporator to give an oil shown by NMR to be the desired product free from organic impurities. An analytically pure sample was obtained by careful reduced-pressure distillation of the crude, azetidine free oil (b.pt. 180°C at 0.05mmHg). Obtained 20g, 69% yield with respect to **2.4**.

5.2.6: Conversion of **2.4** into **2.5**

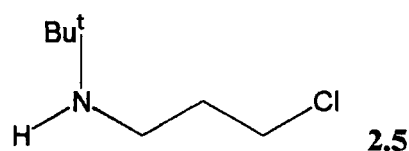

2.4 (14g, 75mmol) was placed in a 500ml beaker in a fume hood with a large magnetic follower. Toluene (200ml) was added to form a suspension. Saturated aqueous NaOH solution was added to the rapidly stirred suspension until the aqueous layer was strongly alkaline and most of the solid had disappeared. The pale yellow organic layer was decanted, dried over NaOH pellets for 15 minutes and used within 1 hour.

N.B. The free amine **2.5** appears to be stable at room temperature for a period of several hours, but if stored for longer or allowed to warm above room temperature it will undergo ring-closure to form N-¹Butyl azetidine.

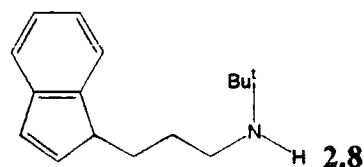

5.2.7: Synthesis of **2.8**

Lithium indenide (9.1g, 75mmol) was dissolved in dry, degassed THF in a 500ml 2-necked flask fitted with a reflux condenser and purged with nitrogen. A freshly prepared toluene solution of **2.5** (from 14g **2.4**, 75mmol) was added to the stirred solution using a syringe. The mixture was refluxed for 4 hours, after which the reaction was worked up using the same procedure as that used for the substituted cyclopentadiene **2.7** to give crude **2.8** as a dark brown oil. A small amount of N-butyl azetidine crystallised on standing and was removed by filtration to give **2.8** which was sufficiently pure for further reactions. An analytically pure sample was obtained by careful reduced-pressure distillation (b.pt. 250°C at 0.001mmHg). Obtained 14.7g, 85% yield with respect to **2.4**.

5.3: Experimental for Chapter 3

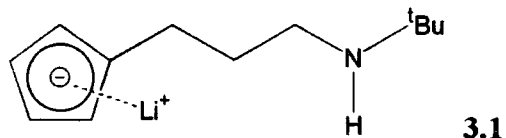

5.3.1: Synthesis of **3.1**

2.7 (1.27g, 7.1mmol) was dissolved in dry, degassed hexane in a nitrogen purged Schlenk tube. ⁿBuLi (5 ml of 1.71M, 8.6 mmol) was added dropwise. A white precipitate formed immediately. After stirring at room temperature for 30 minutes, this precipitate was filtered, washed (2 x 15 ml hexane, 1 x 15ml ether) and dried under reduced pressure to give **3.1** as a highly air-sensitive white powder which was used immediately or stored in a glovebox until required. Obtained 1.3g, 98% yield with respect to **2.7**.

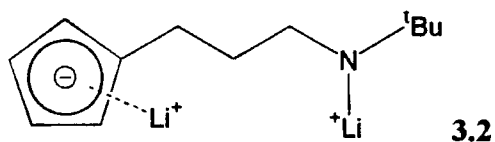

5.3.2: Synthesis of **3.2**

2.7 (0.5g, 2.8mmol) was dissolved in dry, degassed THF (20ml) in a Schlenk tube under nitrogen. ⁿBuLi (3.5ml of 1.62M, 5.6mmol) was added dropwise. After stirring for 30 minutes at room temperature, the solution was reduced in volume to 10ml, and hexane (30ml) was added. The resulting white precipitate was filtered, washed (2 x 10ml hexane, 1 x 10ml diethyl ether) and dried under reduced pressure to give **3.2** as a white solid which like **3.1** was highly air-sensitive. Obtained 0.31g, 58% yield with respect to **2.7**.

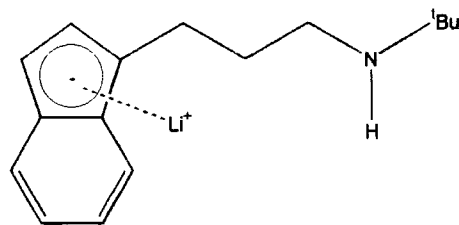

5.3.3: Synthesis of 3.3

3.3

2.8 (0.5g, 2.17mmol) was dissolved in hexane in a nitrogen-purged Schlenk tube. ⁿ Butyl lithium (1.34ml of 1.62M, 2.17mmol) was added dropwise. After stirring at room temperature for 30 minutes the white precipitate of **3.3** was filtered, washed in hexane (10ml) and diethyl ether (10ml) and dried under reduced pressure. Obtained 0.45g, 88% yield with respect to **2.8**.

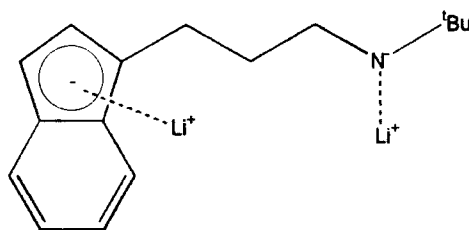

5.3.4: Synthesis of 3.4

3.4

ⁿButyl lithium (2.68ml of 1.62M, 4.34mmol) was added dropwise to a solution of **2.8** (0.5g, 2.17mmol) in THF (20 ml). After stirring for 30 minutes the THF solution was filtered. The filtrate was reduced in volume to 5ml and hexane was added before cooling to -30°C to give **3.4** as a white solid which was filtered, washed (2 x 10ml hexane, 1 x 10ml diethyl ether) and dried under reduced pressure. Obtained 0.28g of **3.4**, 54% yield with respect to **2.8**.

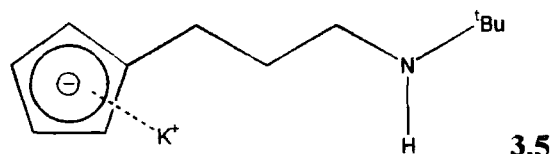

5.3.5 Reaction between 2.7 and KH

2.7 (0.5g, 2.8mmol) was added dropwise to a suspension of excess KH in THF (20ml). The suspension was stirred at 60°C for seven days after which it was filtered. The filtrate was reduced in volume to 5ml and hexane (20ml) was added to give **3.5** in low yield as a highly air-sensitive white solid.

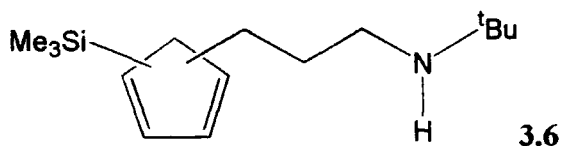

5.3.6: Synthesis of 3.6

2.7 (0.5g, 2.8mol) in hexane (10ml) was allowed to react with ⁿBuLi (1.75ml of 1.62M, 2.8mol) at room temperature. The resulting white precipitate of **3.1** was stirred for 30 minutes at room temperature, filtered, washed, dried and re-dissolved in THF. Me₃SiCl (0.3g, 2.8mmol) was added dropwise. After stirring overnight, the mixture was filtered. The volatiles were removed from the filtrate under reduced pressure to give **3.6** as a yellow moisture-sensitive oil which was further purified by reduced-pressure distillation (b.pt. 200°C at 0.01mmHg). Obtained 0.47g, 66% yield with respect to **2.7**. The trimethylsilyl indenyl derivative **3.8** was obtained in an identical manner.

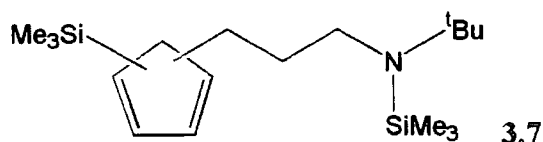

5.3.7: Synthesis of 3.7

2.7 (2g, 11mmol) in THF (20 ml) was allowed to react with n-BuLi (13ml of 1.62M, 22 mmol) at room temperature for 30mins. Me_3SiCl (2.4g, 23mmol) was added and the mixture stirred overnight before filtering. The solvent was removed from the filtrate under reduced pressure to give a yellow, moisture sensitive oil **3.7** which was purified by reduced pressure distillation (b.pt. 220°C at 0.1mmHg). Obtained 2.25g, 63% yield with respect to **2.7**. The bis(trimethylsilyl)indenyl **3.9** was synthesised using an identical procedure.

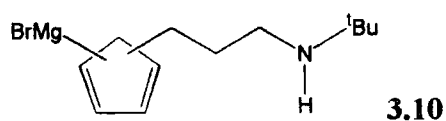

5.3.8: Synthesis of **3.10** and **3.11**

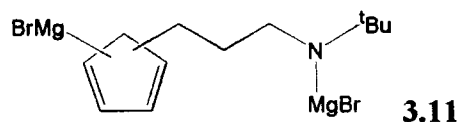

2.8 (0.25g, 1.4mmol) was dissolved in dry, degassed ether in a Schlenk tube. MeMgBr (0.47 ml of 3.0M in ether (Aldrich), 1.4mmol) was added dropwise, giving immediate formation of a white precipitate. The mixture was stirred overnight before removal of the solvent to yield **3.10** as an off-white powder. **3.11** was prepared in a similar manner using THF as the solvent and two equivalents of MeMgBr solution.

5.3.9: Reaction between 2.7 and Me_2Zn

2.7 (0.5g, 2.8mmol) was dissolved in dry, degassed hexane. Me_2Zn (1.4ml of 2M in toluene (Aldrich), 2.8mmol) was added dropwise. After stirring overnight the solvent was removed to give a pale yellow oil.

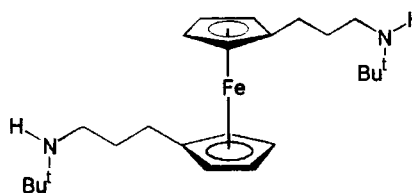

5.3.10: Synthesis of **3.12**

2.7 (2g, 0.011mol) was dissolved in dry, degassed THF in a Schlenk tube under nitrogen. *n*-BuLi (6.8ml of 1.62M, 0.011mol) was added dropwise. After stirring for 30 minutes, anhydrous FeCl_2 (0.64g, 5mmol) was added. The dark coloured mixture was stirred overnight. The solvent was removed under reduced pressure and the residue extracted with petrol (b.pt. 40-60°C) and filtered. The filtrate (which was no longer air sensitive) was reduced in volume on a rotary evaporator to give a bright orange oil **3.12** which was further purified by reduced pressure distillation (b.pt. 150°C at 0.01mmHg). Obtained 1g, 44% yield with respect to **2.7**. Use of $\text{FeCl}_2(\text{Py})_4$ or $\text{FeCl}_2(\text{THF})_n$ instead of anhydrous FeCl_2 failed to improve the yield of this reaction.

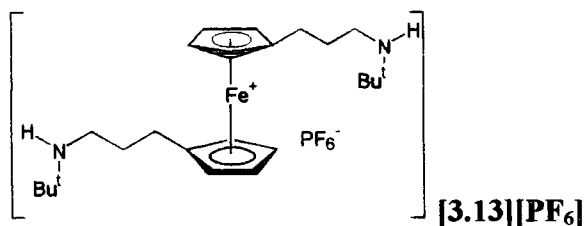

5.3.11: Oxidation of 3.12

3.12 (0.5g, 1.2 mmol) was dissolved in thf (10 ml) in a 50 ml round bottomed flask. An aqueous solution of FeCl₃·6H₂O (0.65 g, 2.4mmol in 20 ml water) was added. The deep blue solution of [3.13][FeCl₄] was stirred for 20 minutes before NH₄PF₆ (0.2g, 1.2mmol) was added. The resulting dark blue precipitate of [3.13][PF₆] was filtered, washed with water and dried in air. Obtained 0.44g, 66% yield with respect to **3.12**.

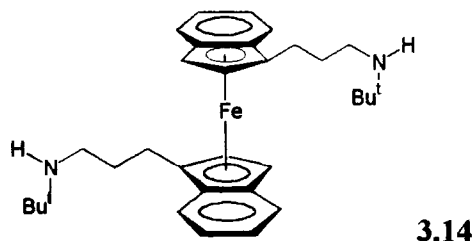

5.3.12: Synthesis of 3.14

2.8 (1g, 4.35mmol) was dissolved in dry, degassed THF in a Schlenk tube under nitrogen. n-BuLi (2.68mls of 1.62M, 4.35mmol) was added. After stirring for 30mins, anhydrous FeCl₂ (0.28g, 2.2mmol) was added. The mixture was stirred overnight at room temperature after which the solvent was removed under reduced pressure. The dark coloured residue was extracted with hexane (3 x 20ml). The hexane extracts were removed by canula filtration and the solvent removed under reduced pressure to give **3.14** as a deep purple oil which was purified by reduced pressure distillation, b.pt. 120°C at 0.001mmHg. Obtained 0.66g, 59% yield with respect to **2.8**.

5.3.13: Reaction between 3.12 and Transition Metal Halides

3.12 (0.5g, 1.2mmol) was dissolved in THF in a 100ml round-bottomed flask. One equivalent of anhydrous MCl_2 ($M = Co, Ni$) or MBr_2 ($M = Mn$) was added as a solid. After stirring for several hours, no noticeable reaction had occurred. Addition of water (10ml) caused an instant exothermic reaction. The colour of the mixture changed from orange to bright green (Co), bright yellow (Ni) or red-brown (Mn), and a solid precipitated. After stirring for a further 1 hour the precipitates were filtered, washed and dried under reduced pressure overnight to ensure complete removal of any non-coordinated water, giving 3.15 (Co), 3.16 (Ni) and 3.17 (Mn) as free-flowing powders.

5.4: Experimental for Chapter 4

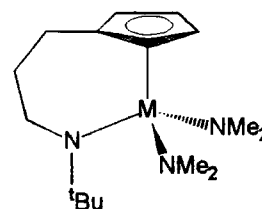

5.4.1: Synthesis of 4.1 and 4.2

$Ti(NMe_2)_4$ (15.27g, 0.068mol) was dissolved in toluene (50ml) in a medium sized Young's ampoule. 2.7 (12.21g, 0.068mol) was added by syringe at room temperature. The mixture was heated to 60°C under nitrogen and stirred for 2 hours, after which the solvent was removed under reduced pressure to give a yellow-brown air- and moisture-sensitive oil which was shown by NMR to be the desired product 4.1, sufficiently pure for use in further reactions. Obtained 15.7g, 74% yield with respect to 2.7. Attempted distillation at 0.01mmHg caused decomposition of the product before distillation temperature was

reached. **4.2** was synthesised in an identical manner from **2.7** (1.34g, 7.5mmol) and $\text{Zr}(\text{NMe}_2)_4$ (2g, 7.5mmol).

5.4.2: Synthesis of **4.3**

$\text{Zr}(\text{NMe}_2)_4$ (0.5g, 1.87mmol) was dissolved in toluene in a Schlenk tube. **2.8** (0.43g, 1.87mmol) was added and the mixture was stirred at 60°C under nitrogen for 7 days. The resulting red solution was filtered and the solvent removed under reduced pressure to give **4.3** as a deep red oil.

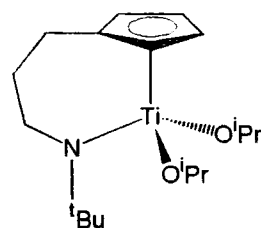

5.4.3: Synthesis of **4.4**

Propan-2-ol (0.438g, 7.3mmol, dried over molecular sieves) was added dropwise to a solution of **4.1** (5mls of 0.73M, 0.365mmol) in dry, degassed toluene (10ml) in a Schlenk tube. The solution changed colour from brown to pale yellow. After stirring overnight at room temperature the solvent was removed to give a pale yellow air and moisture sensitive oil **4.4**. Obtained 0.1g, 73% yield with respect to **4.1**.

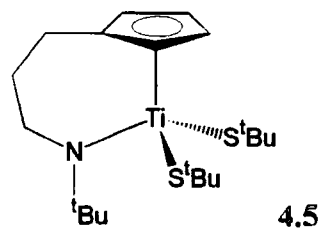

5.4.4: Synthesis of **4.5**

In a fume hood, **4.1** (5mls of 0.73M, 0.365mmol) was diluted with dry, degassed toluene (10mls) in a Schlenk tube under nitrogen. ^tButyl thiol (0.66g, 0.73mmol) was added

dropwise using a syringe. After warming to 60°C for 2 hours the solvent was removed under reduced pressure to give an air and moisture sensitive deep red, viscous oil **4.5**. Obtained 0.12g, 81% yield with respect to **4.1**.

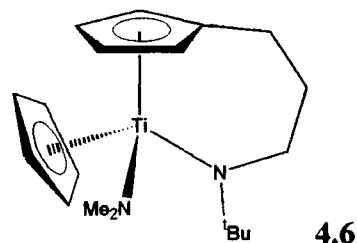

5.4.5: Reaction between **4.1** and C₅H₆

4.1 (5mls of 0.73M in toluene, 3.65 mmol) was dissolved in toluene (10ml). Dry, freshly cracked cyclopentadiene (0.24g, 3.65 mmol) was added dropwise at room temperature using a syringe. After stirring at room temperature for 24 hours the solvent was removed under reduced pressure. The dark brown residue was extracted with petrol (2 x 10ml) and filtered. The solvent was removed from the filtrate, and the resulting brown oil was warmed to 40°C under reduced pressure to remove all traces of unreacted C₅H₆, leaving **4.6** as a brown, viscous oil.

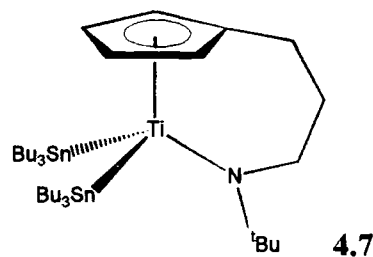

5.4.6: Reaction between **4.1** and ⁿBu₃SnH

4.1 (2.5mls of 1.36M in toluene, 3.4mmol) was dissolved in toluene (10ml) and cooled to -78°C. ⁿBu₃SnH (1.98g, 6.8mmol) was added dropwise using a syringe. The mixture was allowed to warm to room temperature and then refluxed for 2 hours. The

solvent was removed under reduced pressure and the dark brown residue extracted with petrol (2 x 10ml) and filtered. The solvent was removed from the filtrate to give a yellow, free flowing oil.

5.4.7: Reaction between 4.1 and phenylacetylene

4.1 (0.01g, 0.03mmol) was sealed into a 5mm NMR tube under vacuum with phenylacetylene (0.006g, 0.06mmol) and C_6D_6 (1.5ml). The tube was warmed to 60°C for 7 days with NMR spectra being taken at 1 hour intervals for the first 6 hours and subsequently at 12 hour intervals.

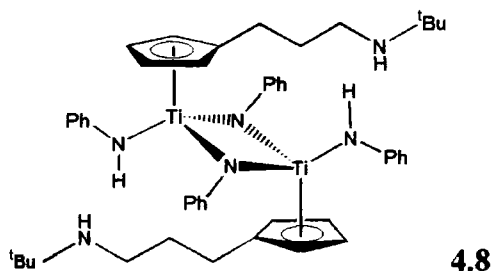

5.4.8: Synthesis of 4.8

4.1 (5mls of 0.73M, 3.65mmol) was dissolved in a further 20mls of toluene. Aniline (0.68g, 7.3mmol) was added. The mixture was stirred overnight to give a red-brown solution. The solvent was removed under reduced pressure and the residue re-dissolved in dry, degassed dichloromethane (25ml). Addition of petroleum ether (25ml, b.pt. 40-60°C) followed by cooling to -30° overnight gave brown, block shaped crystals of **4.8** suitable for X-ray diffraction which were filtered, washed in petrol (2 x 15ml of b.pt. 40-60°C) and carefully dried under reduced pressure.

5.4.9: Reaction between 4.1 and CO₂

4.1 (5mls of 0.73M in toluene, 3.65mmol) was dissolved in more toluene (20mls) in a Schlenk tube. CO₂ gas, generated by allowing solid CO₂ to evaporate, was bubbled through the solution for two hours using a canula. The resulting pale brown solution was filtered and the solvent removed from the filtrate under reduced pressure to give a pale brown, air-sensitive solid **4.9** in low yield.

5.4.10: Reaction between 4.1 and CS₂

4.1 (10mls of 0.73M, 7.3mmol) was dissolved in toluene and cooled to -78°C under nitrogen. CS₂ (5ml, excess) was added dropwise, causing the solution to change colour from brown to bright red. On warming to room temperature a bright orange precipitate **4.10** appeared which was filtered, washed in diethyl ether and dried under reduced pressure. **4.10** was later found to be air- and water-stable. The volatiles were removed from the filtrate to give a viscous, air-sensitive yellow-brown oil which was shown by NMR to be a complex mixture of products. Obtained 3.2g of **4.10**, 83% yield with respect to **4.1** if the structure given in figure 4.7.4 is assumed for **4.10**.

5.5: References for chapter 5

- 1) S. C. Watson and J. F. Eastha, *J. Organomet. Chem.*, 1967, **9**, 165.
- 2) S. K. Sur, *J. Mag. Res.*, 1989, **82**, 169.
- 3) G. M. Diamond, S. Rodewald and R. F. Jordan, *Organometallics*, 1995, **14**, 5.
- 4) D. C. Bradley and I. M. Thomas, *Proc. Chem. Soc.*, 1959, 225; *J. Chem. Soc.*, 1960, 3857
- 5) R. A. Y Jones, A. R. Katritzky and D. L. Trepanier; *J. Chem. Soc. B* 1971, 1300.
- 6) A. K. Hughes, *Verlagen Werkgroep Organometaalchemie en Homogene Katalyse Rijksuniversiteit Gronigen*, 1992, **1**, 30.
- 7) L. A. R. Hall, V. C. Stephens and J. H. Burckhalter; *Org. Synth. Coll.* **4**, 333.

CHAPTER 6

Characterisation Data

6.1: Data for Chapter 2

6.1.1: ^tBuNH(CH₂)₂CO₂CH₂CH₃ (2.1)

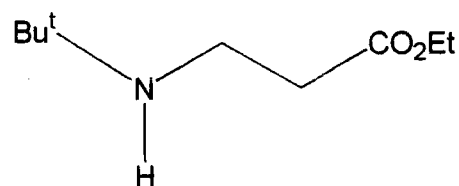

Boiling point: 90°C at 18 mmHg (lit. 90-92°C at 20mmHg)¹

IR: ν /cm⁻¹ 3300 (N-H stretch)
1730 (C=O stretch)

¹H NMR: δ /ppm, 250MHz, CDCl₃

4.00 (q, 2H, ³J_{H-H} = 7.0 Hz, CH₂CH₃)
2.69 (t, 2H, ³J_{H-H} = 6.5 Hz, ^tBuNHCH₂)
2.35 (t, 2H, ³J_{H-H} = 6.5 Hz, CH₂CO₂Et)
1.27 (t, 3H, ³J_{H-H} = 7.0 Hz, CH₂CH₃)
0.97 (s, 9H, C(CH₃)₃)

¹³C{¹H} NMR: δ / ppm, 62.5MHz, CDCl₃

173.0 (CO₂Et)
60.1 (CH₂CH₃)
50.1 (C(CH₃)₃)
37.8 (^tBuNHCH₂)
35.4 (CH₂CO₂Et)
28.8 (C(CH₃)₃)
14.0 (CH₂CH₃)

MS(EI, CI): m/z (%) 173 (100) [M⁺]

| Analysis: | C | H | N |
|------------------|----------|----------|----------|
| calc | 63.9 | 15.1 | 8.3 |
| found | 64.0 | 15.2 | 8.1 |

6.1.2: ^tBuNH(CH₂)₃OH (2.2)

Melting point: 67-70°C (Literature 64-67°C)²

IR: ν/cm^{-1} 3244 (O-H stretch)

3086 (N-H stretch)

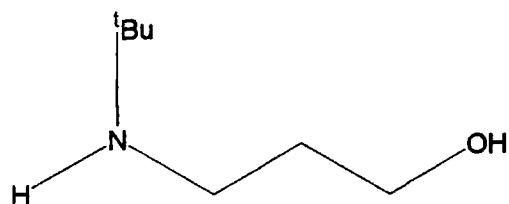

¹H NMR: δ/ppm , 250MHz, CDCl₃

3.83 (t, 2H, ³J_{H-H} = 5.0 Hz, CH₂OH)

3.10 (t, 2H, ³J_{H-H} = 5.0 Hz, ^tBuNHCH₂)

1.69 (quin, 2H, ³J_{H-H} = 5.0 Hz, CH₂CH₂CH₂)

1.23 (s, 9H, C(CH₃)₃)

¹³C{¹H} NMR: δ/ppm , 62.5MHz, CDCl₃

64.9 (CH₂OH)

50.5 (C(CH₃)₃)

43.0 (^tBuNHCH₂)

31.5 (CH₂CH₂CH₂)

28.8 (C(CH₃)₃)

MS (CI): m/z (%) 131 (100) [M⁺]

| Analysis: | C | N | H |
|------------------|----------|----------|----------|
| calc | 64.1 | 10.7 | 13.1 |
| found | 63.5 | 11.2 | 13.2 |

6.1.3: **BuNH(CH₂)₃Br.HBr (2.3)**

IR: ν/cm^{-1} 3162 (N-H)

¹H NMR: δ/ppm , 250MHz, CDCl₃

8.9 (broad s, 2H, ⁺NH₂)

3.6 (t, 2H, ³J_{H-H} = 6.0 Hz, CH₂Br)

3.2 (m, 2H, NCH₂)

2.7 (quin, 2H, ³J_{H-H} = 6 Hz, CH₂CH₂CH₂)

1.56 (s, 9H, C(CH₃)₃)

¹³C{¹H} NMR: δ/ppm , 62.5MHz, CDCl₃

58.2 (C(CH₃)₃)

40.9 (CH₂Br)

29.8 (NCH₂)

28.9 (CH₂CH₂CH₂)

26.0 (C(CH₃)₃)

| analysis: | C | N | H |
|-----------|------|-----|-----|
| calc | 30.6 | 5.1 | 6.2 |
| found | 30.6 | 4.9 | 6.4 |

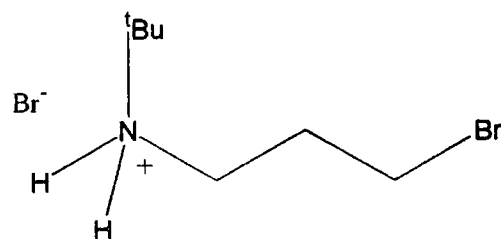

6.1.4: $t\text{BuNH}(\text{CH}_2)_3\text{Cl}\cdot\text{HCl}$ (2.4)

IR: ν/cm^{-1} 3410 (N-H)

^1H NMR: δ/ppm , 250MHz, CDCl_3

9.40 (broad s, 2H, NH)

3.79 (m, 2H, CH₂Cl)

3.20 (broad m, 2H, CH₂N)

2.60 (broad m, 2H, CH₂CH₂CH₂)

1.58 (2, 9H, C(CH₃)₃)

$^{13}\text{C}\{^1\text{H}\}$ NMR: δ/ppm , 62.5MHz, CDCl_3

57.3 (C(CH₃)₃)

42.0 ($t\text{BuN}^+\text{H}_2$ CH₂)

39.5 (CH₂Cl)

29.1 (CH₂CH₂CH₂)

26.0 (C(CH₃)₃)

| Analysis: | C | N | H |
|-----------|------|-----|-----|
| calc | 44.9 | 7.5 | 9.7 |
| found | 45.3 | 7.4 | 9.5 |

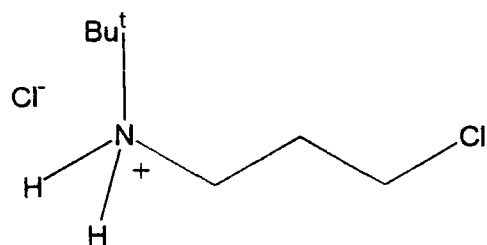

6.1.5: C₇H₁₅N (2.6)

Melting point: 50-52°C

IR: ν/cm^{-1} 2939 (aliphatic C-H stretch)

¹H NMR: δ/ppm , 250MHz, CDCl₃

3.84 (t, 2H, ³J_{H-H} = 5Hz, CH₂N)

2.87 (t, 2H, ³J_{H-H} = 5Hz, CH₂N)

1.73 (quin, 2H, ³J_{H-H} = 5Hz, CH₂CH₂CH₂)

1.16 (s, 9H, C(CH₃)₃)

¹³C{¹H} NMR: δ/ppm , 62.5MHz, CDCl₃

64.6 (CH₂N)

50.4 (C(CH₃)₃)

42.7 (CH₂N)

31.6 (CH₂CH₂CH₂)

28.7 (C(CH₃)₃)

MS (CI): m/z (%) 112 (100) [M⁺]

| Analysis: | C | H | N |
|-----------|------|------|------|
| calc | 74.3 | 12.4 | 13.3 |
| found | 74.1 | 12.5 | 13.4 |

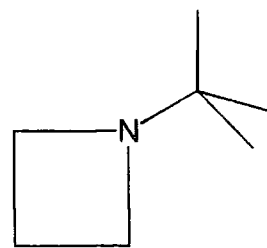

6.1.6: $C_5H_5(CH_2)_3NHC(CH_3)_3$ (2.7)

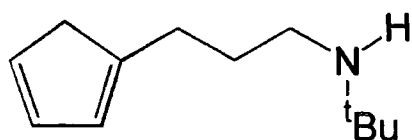

A

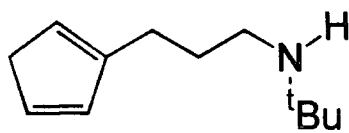

B

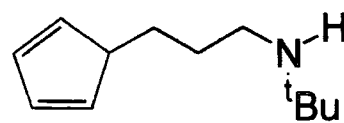

C

Boiling point 180°C at 0.05mmHg

IR: ν/cm^{-1} 3059 (N-H)

1098, 1024, 806 (C-H stretches of Cp ring)

1H NMR: $\delta/$ ppm, 200MHz, $CDCl_3$

6.5, 6.3, 6.2, 6.0, 5.5 (multiplets, CH=CH of all 3 isomers)

3.0 (d, 2H $J = 1.4$ Hz, 2H, ring CH_2 of A or B)

2.9 (d, 2H, $J = 1.3$ Hz, ring CH_2 of A or B)

2.6 (td, 6H, $^3J_{H-H} = 7.2$ Hz, $^4J_{H-H} = 1.5$ Hz, $\underline{CH_2}NH^tBu$ of all three isomers)

2.4 (m, 6H; $C_5H_4\underline{CH_2}$ of all three)

1.8 (m, 6H, $CH_2\underline{CH_2}CH_2$ of all 3)

1.13 (s, 27H, $C(\underline{CH_3})_3$ of all three)

^{13}C NMR: δ/ppm , 62.5MHz, $CDCl_3$

149, 147 (ipso)

135, 134, 132, 126, 125 (ring \underline{CH})

50 (ring $\underline{CH_2}$)

43 ($\underline{C}(\underline{CH_3})_3$)

42 ($^tBuNH\underline{CH_2}$)

41 ($C_5H_5\underline{CH_2}$);

29 ($C(\underline{CH_3})_3$)

27 ($CH_2\underline{CH_2}CH_2$)

GC/MS peaks at: 70 (Mass = 66, C₅H₆, trace amount)
436 (Mass = 132, C₁₀H₁₂, trace amount)
688 (Mass = 179, strong peak, 2.8)
1035 (Mass = 179, medium peak, 2.8)
1048 (Mass = 179, medium peak, 2.8)

| Analysis: | C | H | N |
|------------------|----------|----------|----------|
| Calc: | 80.5 | 11.7 | 7.8 |
| Found: | 80.4 | 11.6 | 7.6 |

6.1.7: C₉H₇(CH₂)₃NHC(CH₃)₃ (2.8)

Boiling point: 250°C at 0.01mmHg

IR: v/cm⁻¹
3398 (N-H)
1098, 1078, 1018 (ring C-H bends)

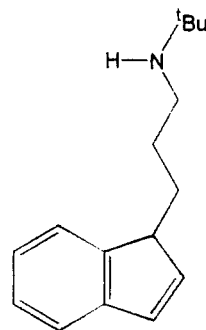

¹H NMR: δ/ ppm, 250MHz, CDCl₃

7.57 - 7.29 (complex multiplets, aromatic C-H)
6.32 (m, 2H, HC=CH of 5-membered ring, superimposed)
3.42 (d, 2H, ¹J_{H-H} = 2Hz, *ipso* CH)
2.77 (t, 2H, ¹J_{H-H} = 7.2Hz, C₉H₇CH₂)
2.69 (td, 2H, ¹J_{H-H} = 7.2Hz, ²J_{H-H} = 0.25Hz, ^tBuNHCH₂)
1.98 (quin, 2H, ¹J_{H-H} = 7.2Hz, CH₂CH₂CH₂)
1.21 (s, 9H, C(CH₃)₃)

¹³C NMR: δ/ppm, 62.5MHz, CDCl₃

131.7 (s, quaternary C of ring)
134.0 (s, quaternary C of ring)
129.4 (dd, ¹J_{C-H} = 120, ²J_{C-H} = 5Hz, CH of 6-membered ring)
127.3 (dd, ¹J_{C-H} = 120, ²J_{C-H} = 2Hz, CH of 6-membered ring)
124.4 (dd, ¹J_{C-H} = 165, ²J_{C-H} = 11Hz, CH of 6-membered ring)
123.6 (dd, ¹J_{C-H} = 145Hz, ²J_{C-H} = 10Hz, CH of 6-membered ring)
118.7 (dd, ¹J_{C-H} = 172Hz, ²J_{C-H} = 10Hz, HC=CH of 5-membered ring)
50.2 (s, C(CH₃)₃)
42.4 (t, ¹J_{C-H} = 135Hz, C₇H₉CH₂)
37.6 (td, ¹J_{C-H} = 116Hz, ²J_{C-H} = 10Hz)
28.9 (q, ¹J_{C-H} = 126Hz, C(CH₃)₃)
25.3 (t, ¹J_{C-H} = 126Hz, CH₂CH₂CH₂)

MS(CI): m/z (%) 230 (100) [M⁺]

| Analysis: | C | H | N |
|------------------|----------|----------|----------|
| Calc. | 83.5 | 10.9 | 6.1 |
| Found | 83.0 | 10.0 | 5.9 |

6.2: Data for Chapter 3

6.2.1: $\text{Li}[\text{C}_5\text{H}_4(\text{CH}_2)_3\text{NH}^t\text{Bu}](\text{THF})_n$ (3.1 $(\text{THF})_n$)

IR: v/cm^{-1} 3200 (N-H stretch)
 1079, 1024 (ring C-H bend)

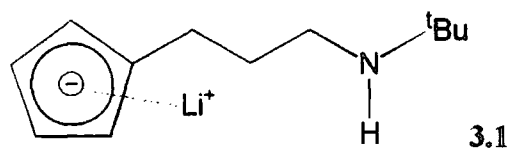

^1H NMR: δ/ppm , 250MHz, C_6D_6

6.35 (t, 2H, $^3J_{\text{H-H}} = 1.8\text{Hz}$)

6.20 (t, 2H, $^3J_{\text{H-H}} = 1.8\text{Hz}$)

3.70 (m, THF)

3.05 (t, 2H, $^3J_{\text{H-H}} = 5.5\text{Hz}$, $\text{C}_5\text{H}_4\text{CH}_2$)

2.65 (quartet, 2H, $^3J_{\text{H-H}} = 5.5\text{Hz}$, $^t\text{BuNHCH}_2$)

1.90 (quin, 2H, $^3J_{\text{H-H}} = 5.5\text{Hz}$, $\text{CH}_2\text{CH}_2\text{CH}_2$)

1.60 (m, THF)

1.01 (s, 9H, $\text{C}(\text{CH}_3)_3$)

6.2.2 Me₃Si(C₅H₄)(CH₂)₃NH^tBu (3.6)

IR: v/cm⁻¹

3400 (N-H stretch)

3047 (aromatic C-H)

2959, 2863 (aliphatic C-H)

1097, 1015, 982 (ring C-H bends)

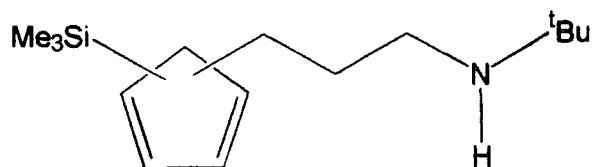

¹H NMR: δ/ppm, 200MHz, CDCl₃

6.62, 6.05, 6.17, 5.60, 5.20 (m, 4H, ring CH of all three isomers)

2.64 (t, 2H, ³J_{H-H} = 7.5Hz, ^tBuNHCH₂)

2.55 (t, 2H, ³J_{H-H} = 7.5Hz, C₅H₄CH₂)

1.80 (quin, 2H, ³J_{H-H} = 7.5Hz, CH₂CH₂CH₂)

1.18 (s, 9H, C(CH₃)₃)

0.96 (t, 1H, ³J_{H-H} = 7.5Hz, NH)

0.15 (s, 9H, Si(CH₃)₃)

¹³C{¹H} NMR: δ/ppm, 62.5MHz, CDCl₃

132.1 (ring CH)

124.7 (ring CH)

56.3 (C(CH₃)₃)

50.1 (^tBuNHCH₂)

43.4 (C₅H₄CH₂)

31.1 (CH₂CH₂CH₂)

29.0 (C(CH₃)₃)

0.98 (Si(CH₃)₃)

6.2.3: Me₃Si(C₅H₄)(CH₂)₃N^tBuSiMe₃ (3.7)

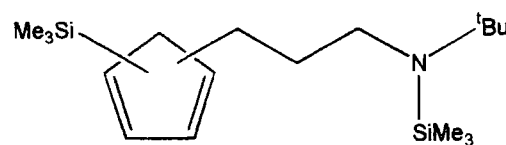

IR: ν/cm^{-1} 3045 (aromatic C-H)
 2950, 2862, 2842 (aliphatic C-H)
 1101, 1051, 1015 (ring C-H bends)

¹H NMR: δ /ppm, 200MHz, CDCl₃

5.45 (broad t, 2H, ³J_{H-H} = 12Hz, ring CH)
5.08 (broad t, 2H, ³J_{H-H} = 12Hz, ring CH)
2.47 (m, 2H, C₅H₄CH₂)
1.92 (m, 2H, ^tBuN(SiMe₃)CH₂)
1.55 (m, 2H, CH₂CH₂CH₂)
1.06 (s, 9H, C(CH₃)₃)
0.09 (s with ²⁹Si satellites, ²J_{H-Si} = 6Hz, 9H, NSi(CH₃)₃)
-0.11 (s with ²⁹Si satellites, ²J_{H-Si} = 6Hz, 9H, C₅H₄Si(CH₃)₃)

¹³C{¹H} NMR: δ /ppm, 62.5MHz, CDCl₃

136.2 (ring CH)
132.1 (ring CH)
130.3 (ring CH)
50.2 (C(CH₃)₃)
42.4 (C₅H₄CH₂)
31.2 (^tBuN(SiMe₃)CH₂)
29.1 (C(CH₃)₃)
27.5 (CH₂CH₂CH₂)
4.1 (with ²⁹Si satellites, ¹J_{C-Si} = 40Hz, NSi(CH₃)₃)
-0.8 (with ²⁹Si satellites, ¹J_{C-Si} = 45Hz, C₅H₄Si(CH₃)₃)

6.2.4: $\{\text{C}_5\text{H}_4(\text{CH}_2)_3\text{NH}^t\text{Bu}\}_2\text{Fe}$ (3.12)

Boiling point: 150°C at 0.01mmHg

IR: ν/cm^{-1} 3350 (N-H)
3087 (aromatic C-H)

1101, 1039, 1021 (ring C-H bend)

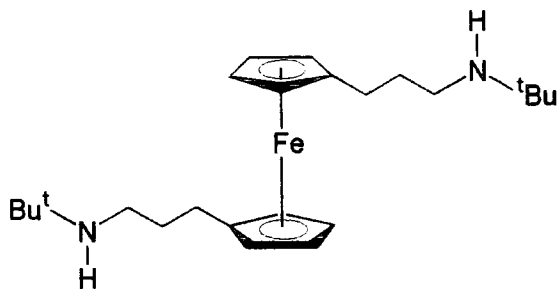

^1H NMR: δ/ppm , 250MHz, CDCl_3

4.08 (s, 3.5H (see note below), C_5H_4)

2.66 (t, 2H, $^3J_{\text{H-H}} = 7.4\text{Hz}$, $\text{C}_5\text{H}_4\text{CH}_2$)

2.46 (t, 2H, $^3J_{\text{H-H}} = 7.2\text{Hz}$, $\text{CH}_2\text{NH}^t\text{Bu}$)

1.91 (quin, 2H, $^3J_{\text{H-H}} = 7.7\text{Hz}$, $\text{CH}_2\text{CH}_2\text{CH}_2$)

1.21 (s, 9H, $\text{C}(\text{CH}_3)_3$)

N.B. The intensities of signals due to protons of co-ordinated cyclopentadienyl rings are consistently lower than expected. This is due to the long relaxation times of such protons.

$^{13}\text{C}\{^1\text{H}\}$ NMR: δ/ppm , 250MHz, CDCl_3

88.8 (C-*ipso*)

68.5 (ring CH)

67.7 (ring CH)

50.7 ($\text{C}(\text{CH}_3)_3$)

42.5 ($^t\text{BuNHCH}_2$)

32.2 ($\text{C}_5\text{H}_4\text{CH}_2$)

28.9 ($\text{C}(\text{CH}_3)_3$)

27.3 ($\text{CH}_2\text{CH}_2\text{CH}_2$)

| MS (CI): m/z (%) | 412 (100) [M^+] | Analysis: | C | H | N |
|---------------------------|----------------------------|------------------|----------|----------|----------|
| | | calc | 69.9 | 9.7 | 6.8 |
| | | found | 69.5 | 10.1 | 6.5 |

6.2.5: $[\{C_5H_4(CH_2)_3NH^tBu\}_2Fe][PF_6]$ (**[3.13]** $[PF_6]$)

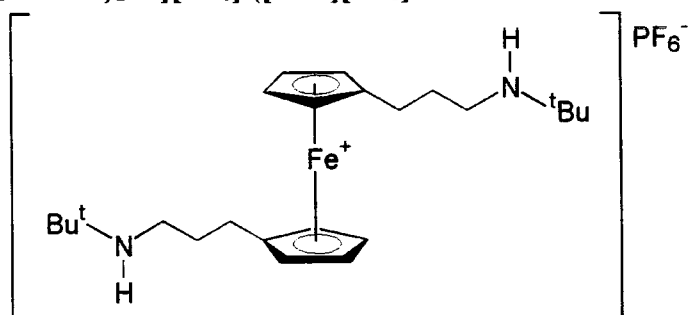

IR: 3246 (N-H)
 1095 - 1032 (ring C-H bends)
 836 (P-F stretch)

Magnetic data: (solid-state, 298k)

$$\chi_g = 13.6 \times 10^{-3} \text{ gmol}^{-1}$$

$$\mu_{\text{eff}} = 5.67 \mu_B$$

| Analysis: | C | H | N |
|------------------|----------|----------|----------|
| calc | 51.7 | 7.8 | 5.0 |
| found | 29.0 | 5.2 | 3.81 |

N.B. Compound **[3.13]** $[PF_6]$ is believed to be contaminated with **[3.13]** $[FeCl_4]$, accounting for the high value for μ_{eff} and the low analysis results.

6.2.6: {C₉H₆(CH₂)₃NH^tBu}₂Fe (3.14)

Boiling point: 120°C at 0.001mmHg

IR: ν/cm^{-1} 3312 (N-H stretch)
3055, 3015 (aromatic C-H stretches)
1019, 1118, 1232 (indenyl C-H bends)

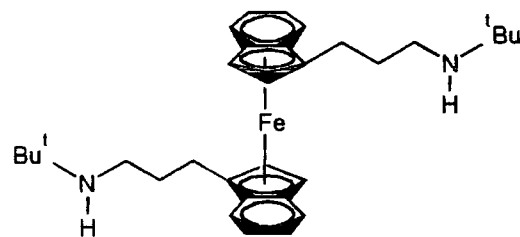

¹H NMR: δ/ppm , 250MHz, CDCl₃

7.6 (d, 1H, ³J_{H-H} = 6Hz C-H of 6-membered ring)
7.45 (d, 1H, ³J_{H-H} = 6Hz, C-H of 6-membered ring)
7.37 (d, ³J_{H-H} = 6Hz, 1H, C-H of 6-membered ring)
7.27 (d, 1H, ³J_{H-H} = 6Hz, C-H of 6-membered ring)
4.50 (broad, 1H, C-H of 5-membered ring)
4.41 (broad, 1H, C-H of 5 membered ring)
2.75 (m, 4H, CH₂N and C₉H₆CH₂ superimposed)
2.00 (quin, 2H, J_{H-H} = 7.5Hz, CH₂CH₂CH₂)
1.21 (s, 9H, C(CH₃)₃)

¹³C NMR: δ/ppm , 62.5MHz, CDCl₃, *ipso* missing. Only one ¹³C resonance was observed for the five-membered ring, and this is discussed in more detail in section 3.5.3.

127.7 (dd, ¹J_{C-H} = 146, ²J_{C-H} = 2Hz, C-H of 6-membered ring)
125.9 (dd, ¹J_{C-H} = 153, ²J_{C-H} = 2Hz, C-H of 6-membered ring)
124.4 (dd, ¹J_{C-H} = 137, ²J_{C-H} = 2.5Hz, C-H of 6-membered ring)
122.7 (dd, ¹J_{C-H} = 135, ²J_{C-H} = 2.5Hz, C-H of 6-membered ring)
118.8 (dd, ¹J_{C-H} = 154, ²J_{C-H} = 5Hz, C-H of 5-membered ring)
50.2 (s, C(CH₃)₃)
42.5 (t, ¹J_{C-H} = 137, C₉H₆CH₂)
37.6 (td, ¹J_{C-H} = 130, ²J_{C-H} = 2.5Hz, CH₂NH^tBu)
29.0 (q, ¹J_{C-H} = 127, C(CH₃)₃)
25.6 (t, ¹J_{C-H} = 128, CH₂CH₂CH₂)

6.2.7: Data for 3.15 (from 3.12 + CoCl₂)

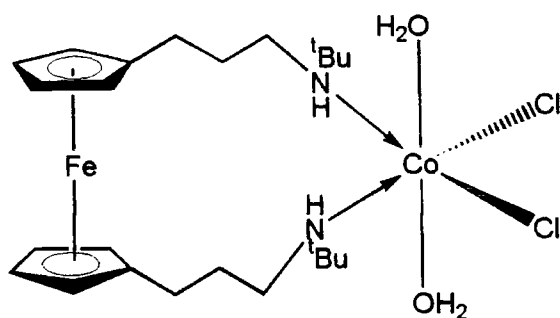

IR: 3491 (O-H stretch of H₂O)
 3178 (N-H stretch)
 3090 (aromatic C-H stretch)
 2604 - 2950 (aliphatic C-H stretch)
 1620 (O-H bend of H₂O)
 815, 994-1096 (C-H bend of ring)
 357, 454, 485 (Co-Cl)

Solid state: χ_M 6.483 x 10⁻³ mol⁻¹

μ_{eff} 3.94 μ_B

Solution: χ_M 3.56 x 10⁻³ mol⁻¹

μ_{eff} 2.92 μ_B

| Analysis: | C | H | N | Fe | Co | Cl |
|------------------|----------|----------|----------|-----------|-----------|----------------------------------|
| calc | 49.9 | 7.7 | 4.8 | 9.7 | 10.2 | 12.3 (calc for proposed struct.) |
| found | 52.2 | 8.1 | 4.4 | 8.8 | 9.2 | 9.1 |

6.2.8: Data for 3.16 (from 3.12 + NiCl₂)

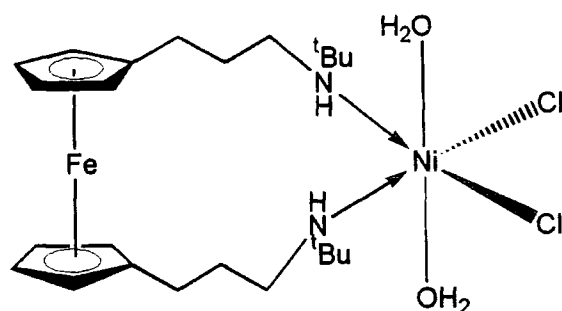

IR: 3430 (O-H stretch of H₂O)
 3178 (N-H stretch)
 3088 (aromatic C-H stretch)
 2600- 2965 (aliphatic C-H stretches)
 1616 (O-H bend of H₂O)
 802, 815, 1018- 1095 (C-H bends of ring)
 357 (Ni-Cl)

Magnetic susceptibility:

Solid state: χ_M 3.766 x 10⁻³ mol⁻¹

μ_{eff} 3.00 μ_B

Solution: χ_M 3.536 x 10⁻³ mol⁻¹

μ_{eff} 2.91 μ_B

| Analysis: | C | H | N | Fe | Ni | Cl |
|-----------|------|-----|-----|-----|------|-------------------------------|
| calc | 49.8 | 7.7 | 4.8 | 9.7 | 10.2 | 12.3 (for proposed structure) |
| found | 44.7 | 6.9 | 3.8 | 8.1 | 10.4 | 13.7 |

6.2.9: Data for 3.17 (from 3.12 + MnBr₂)

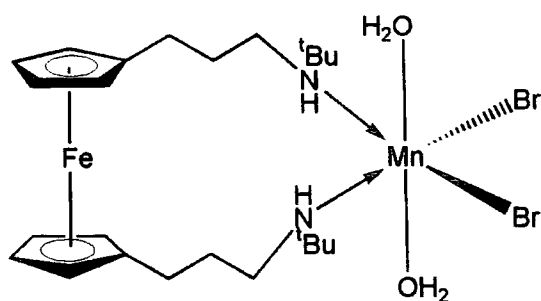

IR: 3429 (O-H stretch of H₂O)
3178 (N-H stretch)
2600- 2970 (aliphatic C-H stretch)
1589 - 1688 (O-H bend of H₂O)
803, 814, 1010- 1096 (C-H bend of ring)

Magnetic susceptibility

Solid State: χ_M $0.517 \times 10^{-3} \text{ mol}^{-1}$
 μ_{eff} $1.11 \mu_B$

Solution: χ_M $0.3042 \times 10^{-3} \text{ mol}^{-1}$
 μ_{eff} $0.85 \mu_B$

6.3: Data for Chapter 4

6.3.1: $(C_5H_4(CH_2)_3N^tBu)Ti(NMe_2)_2$ (4.1)

IR: 3090 (aromatic C-H stretch)
2760 - 2960 (aliphatic C-H stretch)
963, 1046-1140 (C-H bends of
cyclopentadienyl ring)

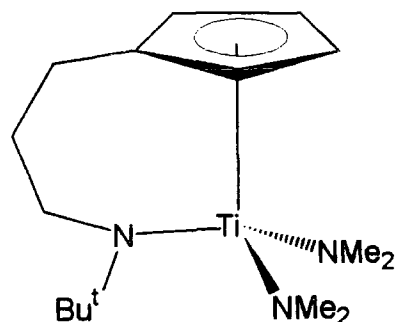

1H NMR: δ /ppm, 250MHz, C_6D_6

5.90 (t, 2H, $^3J = 2.5$ Hz, ring)
5.85 (t, 2H, $^3J = 2.5$ Hz, ring)
3.12 (s, 12H, $N(CH_3)_2$)
2.57 (m, 4H, $C_5H_4CH_2$ and CH_2N^tBu superimposed)
1.71 (quin, 2H, $^3J = 7$ Hz, $CH_2CH_2CH_2$)
1.02 (s, 9H, $C(CH_3)_3$)

$^{13}C\{^1H\}$ NMR: δ /ppm, 62.5MHz, $CDCl_3$

110, 109 (ring $C-H$)
49 ($N(CH_3)_2$)
42.5 ($C(CH_3)_3$)
42 (CH_2N^tBu)
39 ($C_5H_4CH_2$)
29 ($CH_2CH_2CH_2$)

MS (CI): m/z (%) 358 (33) [$M^+ + HNMe_2$], 313 (100) [M^+], 269 (40) [$M^+ - NMe_2$]

MS (EI): m/z (%) 402 (48) [4.1a], 358 (40) [4.1a - NMe_2], 313 (100) [M^+], 269 (82) [$M^+ - NMe_2$], 224 (12) [$Ti(NMe_2)_4$], 210 (44) [$M^+ - 2NMe_2 - CH_3$], 180 (24) [$Ti(NMe_2)_4 - NMe_2$]

| Analysis: | C | H | N |
|-----------|------|------|------|
| calc | 61.3 | 10.0 | 13.4 |
| found | 61.2 | 10.5 | 13.8 |

6.3.2: 4.1 after distillation (4.1a)

IR: ν/cm^{-1}

3086 (aromatic C-H)

2760-2961 (aliphatic C-H)

950, 1040-1136 (C-H bends of ring)

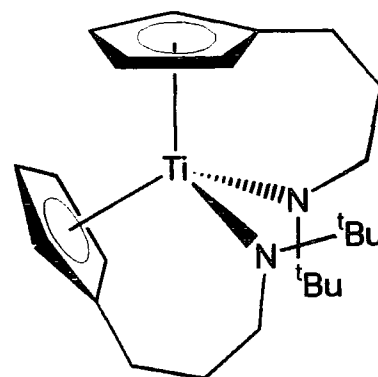

^1H NMR: δ/ppm , 250MHz, CDCl_3

6.13 (t, 2H, $^3J_{\text{H-H}} = 3\text{Hz}$, ring CH)

5.95 (t, 2H, $^3J_{\text{H-H}} = 3\text{Hz}$, ring CH)

5.86 (t, 2H, $^3J_{\text{H-H}} = 3\text{Hz}$, ring CH)

5.70 (t, 2H, $^3J_{\text{H-H}} = 3\text{Hz}$, ring CH)

3.10 (s, 12H, $\text{Ti}\{\text{N}(\text{CH}_3)_2\}_4$)

2.61 (m, 8H, $\text{C}_5\text{H}_4\text{CH}_2$ and CH_2N superimposed)

1.76 (m, 4H, $\text{CH}_2\text{CH}_2\text{CH}_2$)

1.13 (s, 18H, $\text{C}(\text{CH}_3)_3$)

$^{13}\text{C}\{^1\text{H}\}$ NMR: δ/ppm , 62.5MHz, CDCl_3

111.1 (ring CH)

110.0 (ring CH)

109.1 (ring CH)

108.9 (ring CH)

51.0 ($\text{C}(\text{CH}_3)_3$)

50.1 ($\text{Ti}\{\text{N}(\text{CH}_3)_2\}_4$)

42.4 ($\text{C}_5\text{H}_4\text{CH}_2$)

31.9 ($\text{CH}_2\text{N}^t\text{Bu}$)

29.0 ($\text{C}(\text{CH}_3)_3$)

27.0 ($\text{CH}_2\text{CH}_2\text{CH}_2$)

6.3.3: $(C_5H_4(CH_2)_3N^tBu)Zr(NMe_2)_2$ (4.2)

1H NMR: δ/ppm , 250MHz, C_6D_6

6.16 (t, 2H, $^3J_{H-H} = 3Hz$, ring CH)

6.14 (t, 2H, $^3J_{H-H} = 3Hz$, ring CH)

3.11 (s, 12H, $N(CH_3)_2$)

2.45 (m, 4H, $C_5H_4CH_2$ and CH_2N^tBu)

1.60 (quin, 2H, $^3J_{H-H} = 8Hz$, $CH_2CH_2CH_2$)

1.16 (s, 9H, $C(CH_3)_3$)

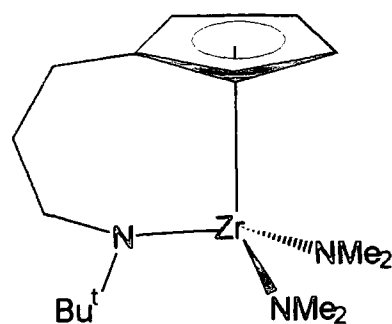

$^{13}C\{^1H\}$ NMR: δ/ppm , 62.5MHz, C_6D_6 , *ipso* missing

109.7 (ring CH)

109.5 (ring CH)

49.3 (C $(CH_3)_3$)

44.7 ($N(\underline{C}H_3)_2$)

41.9 ($C_5H_5\underline{C}H_2$)

33.1 ($\underline{C}H_2N^tBu$)

29.1 ($C(\underline{C}H_3)_3$)

26.7 ($CH_2\underline{C}H_2CH_2$)

6.3.4: (C₉H₆(CH₂)₃N^tBu)Zr(NMe₂)₂ (4.3)

IR: ν/cm^{-1} 3066 (aromatic CH)
 2765-2962 (aliphatic CH)
 940, 1019-1130 (CH bends of ring)

¹H NMR: δ/ppm , 250MHz, CDCl₃

7.20-7.65 (m, CH of 6-membered ring)
5.06 (d, 1H, ³J_{H-H} = 3Hz, CH of 5-membered ring)
4.97 (d, 1H, ³J_{H-H} = 3Hz, CH of 5-membered ring)
2.72 (s, 12H, N(CH₃)₂)
2.50 (m, 4H, C₉H₆CH₂ and CH₂N^tBu)
1.94 (quin, 2H, ³J_{H-H} = 6.5Hz, CH₂CH₂CH₂)
1.93 (s, 9H, C(CH₃)₃)

¹³C{¹H} NMR: δ/ppm , 62.5MHz, CDCl₃, *ipso* missing

125.9 (CH of 6-membered ring)
124.4 (CH of 6-membered ring)
123.6 (CH of 6-membered ring)
121.9 (CH of 6-membered ring)
118.2 (CH of 5-membered ring)
115.8 (CH of 5-membered ring)
50.3 (C(CH₃)₃)
43.2 (N(CH₃)₂)
42.4 (C₉H₆CH₂)
37.6 (CH₂N^tBu)
29.0 (C(CH₃)₃)
25.6 (CH₂CH₂CH₂)

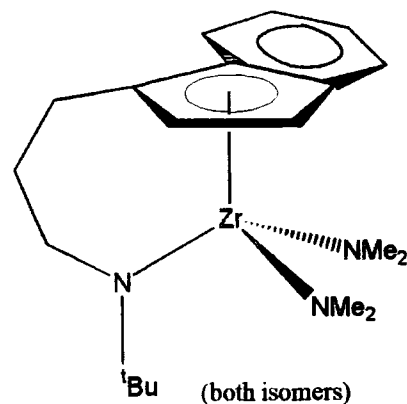

6.3.5: (C₅H₄(CH₂)₃N^tBu)Ti(OⁱPr)₂

IR: v/cm⁻¹ 3046, 3090 (aromatic C-H stretch)
 2859-2961 (aliphatic C-H stretch)
 990, 1100-1230 (C-H bends of ring)

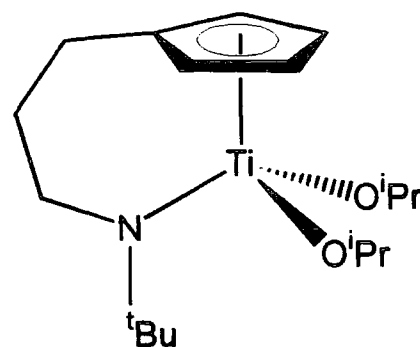

¹H NMR: δ/ppm, 250MHz, CDCl₃

6.21 (t, 2H, ³J_{H-H} = 2.5Hz, ring)
6.12 (t, 2H, ³J_{H-H} = 2.5Hz, ring)
4.60 (septet, 2H, ³J_{H-H} = 6Hz, (CH₃)₂CHO)
2.68 (m, 4H, C₅H₄CH₂ and CH₂N^tBu superimposed)
1.80 (quin, 2H, ³J_{H-H} = 7Hz, CH₂CH₂CH₂)
1.18 (d, 12H, ³J_{H-H} = 7Hz, OCH(CH₃)₂)
1.17 (s, 9H, C(CH₃)₃)

¹³C NMR: δ/ppm, 62.5MHz, CDCl₃

111.5 (ring CH)
111.0 (ring CH)
50.2 (C(CH₃)₃)
42.4 (OCH(CH₃)₂)
31.2 (^tBuNCH₂)
28.9 (OCH(CH₃)₂)
27.3 (C₅H₄CH₂)
25.9 (NC(CH₃)₃)
25.3 (CH₂CH₂CH₂)

MS(CI): m/z (%) 343 (10) [M⁺]
 179 (70) [C₅H₅(CH₂)₃NH^tBu]

6.3.6: (C₅H₄(CH₂)₃N^tBu)Ti(S^tBu)₂ (4.5)

¹H NMR: δ/ppm, 250MHz, CDCl₃

- 6.62 (t, ³J_{H-H} = 2.5Hz, C₅H₄)
- 6.50 (t, ³J_{H-H} = 2.5Hz, C₅H₄)
- 2.86 (t, 2H, ³J_{H-H} = 7.6Hz, CH₂N^tBu)
- 2.68 (q, 2H, ³J_{H-H} = 7.6Hz, CH₂C₅H₄)
- 1.86 (m, 2H, ³J_{H-H} = 7.6Hz, CH₂CH₂CH₂)
- 1.61 (s, 18H, SC(CH₃)₃)
- 1.17 (s, 9H, NC(CH₃)₃)

¹³C NMR: δ/ppm, 62.5MHz, CDCl₃

- 113.6 (ring)
- 111.8 (ring)
- 53.7 (SC(CH₃)₃)
- 50.2 (NC(CH₃)₃)
- 42.1 (CH₂N^tBu)
- 34.9 (SC(CH₃)₃)
- 32.5 (C₅H₄CH₂)
- 29.5 (CH₂CH₂CH₂)
- 29.0 (NC(CH₃)₃)

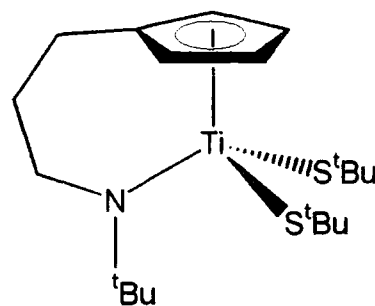

6.3.7: $(C_5H_4(CH_2)_3N^tBu)Ti(C_5H_5)NMe_2$ (4.6)

IR: 3055 (aromatic C-H)
2760- 2960 (aliphatic C-H)
1017- 1137 (C-H bends of
co-ordinated Cp rings)

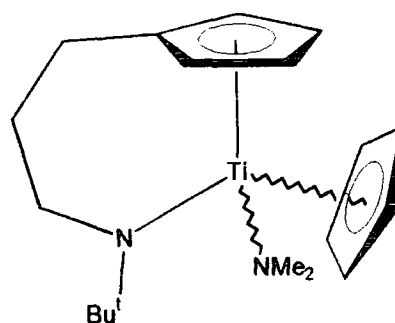

1H NMR: δ / ppm, 200MHz, $CDCl_3$

6.04 (s, C_5H_5)
5.92 (t, $^3J_{H-H} = 2.7\text{Hz}$, $C_5H_4CH_2$)
5.83 (t, $^3J_{H-H} = 2.7\text{Hz}$, $C_5H_4(CH_2)$)
3.05 (s, 6H, $N(CH_3)_2$)
2.56 (m, 4H, $^3J_{H-H} = 1\text{Hz}$, $C_5H_4CH_2$ and tBuNHCH_2 superimposed)
1.73 (quin, 2H, $^3J_{H-H} = 1\text{Hz}$, $CH_2CH_2CH_2$)
1.08 (s, 9H, $C(CH_3)_3$)

$^{13}C\{^1H\}$ NMR: δ /ppm, 62.5MHz, $CDCl_3$, all quaternary C's missing

118.0 ($C_5H_4CH_2$)
117.5 ($C_5H_4CH_2$)
116.9 (C_5H_5)
52.1 ($N(CH_3)_2$)
46.0 (CH_2NH^tBu)
43.9 ($C_5H_4CH_2$)
39.0 ($CH_2CH_2CH_2$)
28.9 ($C(CH_3)_3$)

6.3.8: $(C_5H_4(CH_2)_3N^tBu)Ti(Sn^nBu_3)_2$ (4.7)

1H NMR: δ /ppm, 250MHz, $CDCl_3$

- 6.03 (t, $^3J_{H-H} = 3Hz$, C_5H_4)
- 5.93 (t, $^3J_{H-H} = 3Hz$, C_5H_4)
- 1.80 (t, $^3J_{H-H} = 8Hz$, CH_2CH_2 of nBu)
- 1.45 (q, $^3J_{H-H} = 8Hz$, CH_2CH_3 of nBu)
- 1.14 (t, $^3J_{H-H} = 8Hz$, CH_2CH_2 of nBu)
- 1.10 (s, $C(CH_3)_3$)
- 0.99 (t, $^3J_{H-H} = 8Hz$, CH_2CH_3 of nBu)

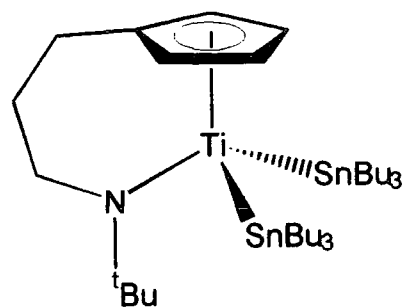

Note: signals for $C_5H_4CH_2$, $CH_2CH_2CH_2$ and CH_2NH^tBu are swamped by the signals due to nBu protons. This is discussed in section 4.5.4.

$^{13}C\{^1H\}$ NMR: δ /ppm, 62.5MHz, $CDCl_3$, quaternary C's missing

- 110.0 (ring \underline{CH})
- 109.0 (ring \underline{CH})
- 49.5 ($C_5H_4\underline{CH_2}$)
- 42.3 ($^tBuN\underline{CH_2}$)
- 30.6 ($SnCH_2CH_2CH_2\underline{CH_3}$)
- 29.0 ($NC(\underline{CH_3})_3$)
- 27.4 ($SnCH_2CH_2\underline{CH_2}CH_3$)
- 27.0 ($CH_2\underline{CH_2}CH_2$)
- 13.6 ($SnCH_2\underline{CH_2}CH_2CH_3$)
- 9.9 (with ^{119}Sn and ^{117}Sn sats appearing as finely spaced doublets, $^1J_{C-Sn}$
= 60Hz, $Sn\underline{CH_2}CH_2CH_2CH_3$)

6.3.9: $[(\text{Cp}(\text{CH}_2)_3 \text{NtBu})\text{Ti}(\text{NPh})]_2(\mu\text{-NPh})_2$ 4.8

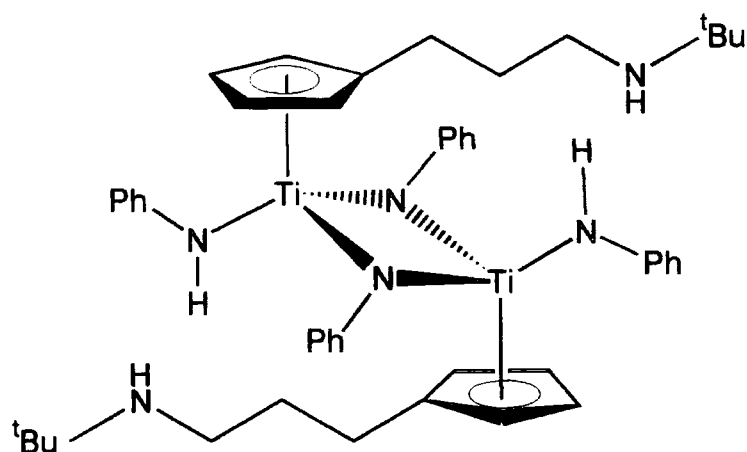

IR: ν/cm^{-1}

- 3392 (N-H stretch)
- 3038 (aromatic C-H)
- 2860, 2956 (aliphatic C-H)
- 994, 1025, 1069, 1099 (ring C-H bends)
- 761, 816, 857 (ring C-H bends)

^1H NMR: δ/ppm , 250MHz, CDCl_3 (all are 4.8a unless otherwise stated)

- 8.67 (N-H of 4.8b)
- 7.40 (t, *meta* C-H of phenyl)
- 7.3 (m, *meta* C-H of phenyl groups)
- 6.95 (m, phenyl of 4.8b)
- 6.87 (t, phenyl of 4.8b)
- 6.78 (d, $^3J_{\text{H-H}} = 7.8\text{Hz}$, *ortho* C-H)
- 6.59 (d, $^3J_{\text{H-H}} = 7.5\text{Hz}$ *ortho* C-H)
- 6.31 (q, C_5H_4 of 4.8b)
- 6.21 (t, C_5H_4 of 4.8b)
- 6.19 (t, $^3J_{\text{H-H}} = 2.6\text{Hz}$, C_5H_4)

- 6.13 (t, $^1J_{\text{H-H}} = 2.6\text{Hz}$, C_5H_4)
 3.74 (broad s, 2H, $\text{C}_6\text{H}_5\text{NH}$)
 2.38 (q, 4H, $^3J_{\text{H-H}} = 7.3\text{Hz}$, $\text{CH}_2\text{NH}^t\text{Bu}$)
 2.23 (t, 4H, $^3J_{\text{H-H}} = 7.3\text{Hz}$, $\text{C}_5\text{H}_4\text{CH}_2$)
 1.50 (quin, 4H, $^3J_{\text{H-H}} = 7.3\text{Hz}$, $\text{CH}_2\text{CH}_2\text{CH}_2$)
 1.13 (s, $\text{C}(\text{CH}_3)_3$ of **4.8b**)
 1.09 (s, 18H, $\text{C}(\text{CH}_3)_3$ of **4.8a**)
 0.45 (t, 2H, $^3J_{\text{H-H}} = 7.3\text{Hz}$, $\text{CH}_2\text{NH}^t\text{Bu}$)

$^{13}\text{C}\{^1\text{H}\}$ NMR: δ/ppm , 62.5MHz, CDCl_3 , **4.1a** unless otherwise stated

- 157.9 (*para*- $\underline{\text{C}}\text{H}$ of phenyl)
 155.3 (*para*- $\underline{\text{C}}\text{H}$)
 128.9 (*meta*- $\underline{\text{C}}\text{H}$)
 128.5 (*meta*- $\underline{\text{C}}\text{H}$)
 122.5 (phenyl $\underline{\text{C}}\text{H}$ of **4.8b**)
 120.3 (*ortho*- $\underline{\text{C}}\text{H}$)
 119.1 (phenyl $\underline{\text{C}}\text{H}$ of **4.8b**)
 118.5 (phenyl $\underline{\text{C}}\text{H}$ of **4.8b**)
 117.6 (*ortho*- $\underline{\text{C}}\text{H}$)
 114.7 (ring $\underline{\text{C}}\text{H}$ of **4.8b**)
 114.1 (ring $\underline{\text{C}}\text{H}$ of **4.8b**)
 113.9 (ring $\underline{\text{C}}\text{H}$)
 113.6 (ring $\underline{\text{C}}\text{H}$)
 50.0 ($\underline{\text{C}}(\text{CH}_3)_3$)
 42.7 ($\underline{\text{C}}\text{H}_2\text{NH}^t\text{Bu}$ of **4.8b**)

42.0 ($\underline{\text{C}}\text{H}_2\text{NH}^t\text{Bu}$)
32.2 ($\text{C}_5\text{H}_4\underline{\text{C}}\text{H}_2$ of **4.8b**)
31.7 ($\text{C}_5\text{H}_4\underline{\text{C}}\text{H}_2$)
29.2($\text{C}(\underline{\text{C}}\text{H}_3)_3$ of **4.8b**)
29.0 ($\text{C}(\underline{\text{C}}\text{H}_3)_3$)
27.0($\text{CH}_2\underline{\text{C}}\text{H}_2\text{CH}_2$ **4.8b**)
26.9 ($\text{CH}_2\underline{\text{C}}\text{H}_2\text{CH}_2$)

^{13}C NMR: δ /ppm, 75MHz, solid-state

158, 154 ($\underline{\text{C}}\text{N}$ of phenyl)
129, 121 ($\underline{\text{C}}\text{H}$ of phenyl)
50 ($\underline{\text{C}}\text{H}_2$)
42 ($\underline{\text{C}}\text{H}_2$)
30 ($\text{C}(\underline{\text{C}}\text{H}_3)_3$)

X-ray data: see appendix B

6.3.10: 4.1 + CS₂ (4.10)

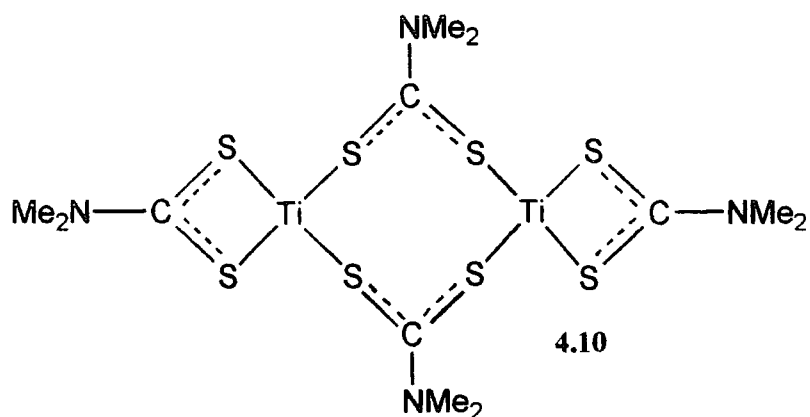

IR: ν/cm^{-1} 2850-2960 (aliphatic C-H)

1506 (C-N)

¹³C NMR: δ/ppm , 75MHz, solid-state

206.9, 206.1, 204.8, 204.2 (CS)

41.8, 41.2, 39.2, 38.5, 37.7 (N(CH₃)₂)

¹⁵N NMR: δ/ppm , solid-state

-238.5

-235.8

-232.2

-230.3

| Analysis: | C | H | N | S |
|------------------|----------|----------|----------|----------|
| calc | 25.0 | 4.2 | 9.7 | 44.4 |
| found | 23.9 | 4.5 | 10.2 | 44.8 |

Appendix A: Magnetic Susceptibility Determination

A1: Solid-state magnetic susceptibilities

Magnetic susceptibilities were determined using a Johnson-Matthey-Evans (JME) magnetic susceptibility balance using a variation of the Gouy method¹ which involves monitoring the change in weight of a sample of paramagnetic compound when it is placed in a magnetic field (and hence the force exerted on the sample by the magnetic field).

Procedure

An empty sample tube was placed in the JME balance and the reading R_0 was noted (R_0 is always negative as glass is diamagnetic). The tube was carefully packed with an accurately weighed, finely powdered sample and a second reading R was taken (if the compound is paramagnetic the R is positive and high). The length of the sample l (in cm) was also noted as was the temperature T (in K) in the balance room. The balance was calibrated and the balance constant C determined using $\text{HgCo}(\text{NCS})_4$ as a standard compound ($\mu_{\text{eff}} = 4.35 \mu_B$ at 298K).¹

Calculation

Mass susceptibility χ_g :

$$\chi_g = \frac{Cl(R-R_0)}{10^9 m} \text{ cmg}^{-1} \quad (C = \text{balance constant, } m = \text{mass of sample in g})$$

Molar Susceptibility χ_m :

$$\chi_m = M\chi_g \text{ cmmol}^{-1} \quad (M = \text{relative molecular mass of sample})$$

Effective Magnetic Moment μ_{eff} :

$$\mu_{\text{eff}} = \left(\frac{3kT\chi_m}{N\mu_B^2} \right)^{1/2} \mu_B \quad (T = \text{temperature in K})$$

substituting constants gives:

$$\mu_{\text{eff}} = 2.828(\chi_m T)^{1/2} \mu_B$$

A2: Solution magnetic susceptibilities

Solution state magnetic susceptibilities were determined using Evans' NMR method² in which the change in the ¹H NMR chemical shift value observed when a paramagnetic species is dissolved in a solvent is used to calculate the magnetic susceptibility of the paramagnetic species.

Procedure

Exact weighed samples of the paramagnetic compounds **3.15**, **3.16** and **3.17** were dissolved in exactly weighed quantities of CDCl₃ in 5mm NMR tubes. NMR spectra of all three samples and of a sample containing blank solvent were run at 250MHz.

Calculation

If the protons of the solute do not interact with the solvent then the shift in frequency Δf is given by:

$$\chi_{\text{mass}} = \frac{3\Delta f}{4\pi f m} + \chi_0 + \chi_0 \frac{(d_0 - d_s)}{m}$$

where:

- Δf is the change in frequency on dissolving the paramagnetic species (Hz)
- f is the spectrometer frequency (250×10^6 Hz in this case)
- m is the mass of substance in 1ml of solution (gml^{-1})
- χ_{mass} is the mass susceptibility of the solute
- χ_0 is the mass susceptibility of the solvent
- d_0 is the density of the solvent (gcm^{-3})
- d is the density of the solution (gcm^{-3})

The last two terms of this equation are in practice small, of opposite sign and almost equal magnitude and so can be neglected. The factor of $3/4\pi$ is a function of the orientation of the magnetic field of the Fourier Transform NMR spectrometer.

From this:

$$\chi_{\text{mass}} = \frac{3\Delta f}{4\pi f m}$$

molar susceptibility $\chi_M = \chi_{\text{mass}} M$ ($M = \text{R.M.M. of solute}$)

and using the same equations as for the solid state calculations above, the effective magnetic moment is given by:

$$\mu_{\text{eff}} = 2.828(\chi_M T)^{1/2} \mu_B$$

A3: Magnetic data for 3.15, 3.16 and 3.17 at 298k

Solid-state:

| Compound | m/g | l/cm | r-r ₀ | $\chi_{\text{mass}}/\text{g}^{-1}$ | χ_M/mol^{-1} | μ_{eff}/μ_B |
|------------------------------|-----------------------|------|------------------|------------------------------------|--------------------------|--------------------------|
| HgCo(NCS)₄ | 9.59×10^{-3} | 2.7 | 491 | 1.644×10^{-6} | 8.09×10^{-3} | 4.35 |
| 3.15 | 1.99×10^{-3} | 2.8 | 98 | 1.4×10^{-5} | 8.1×10^{-3} | 4.39 |
| 3.16 | 2.99×10^{-3} | 2.5 | 77 | 6.5×10^{-6} | 3.8×10^{-3} | 3.00 |
| 3.17 | 4.17×10^{-3} | 2.4 | 13 | 7.6×10^{-7} | 0.5×10^{-3} | 1.11 |

Solution-state:

| Compound | m/gml⁻¹ | Δf/Hz | $\chi_{\text{mass}}/\text{g}^{-1}$ | $\chi_{\text{M}}/\text{mol}^{-1}$ | $\mu_{\text{eff}}/\mu_{\text{B}}$ |
|-----------------|---------------------------|---------------------------------|--|---|---|
| 3.15 | 0.9×10^{-3} | 1.29 | 6.2×10^{-6} | 3.6×10^{-3} | 2.92 |
| 3.16 | 0.9×10^{-3} | 1.28 | 6.1×10^{-6} | 3.5×10^{-3} | 2.91 |
| 3.17 | 1.4×10^{-3} | 0.14 | 0.45×10^{-6} | 0.0×10^{-3} | 0.85 |

References

- 1) Procedure taken from second-year undergraduate laboratory course in inorganic chemistry, University of Durham, 1996.
- 2) S. K. Sur, *J. Mag. Res.*, 1989, **82**, 169.

Appendix B: X-ray Crystallographic Data for 4.8

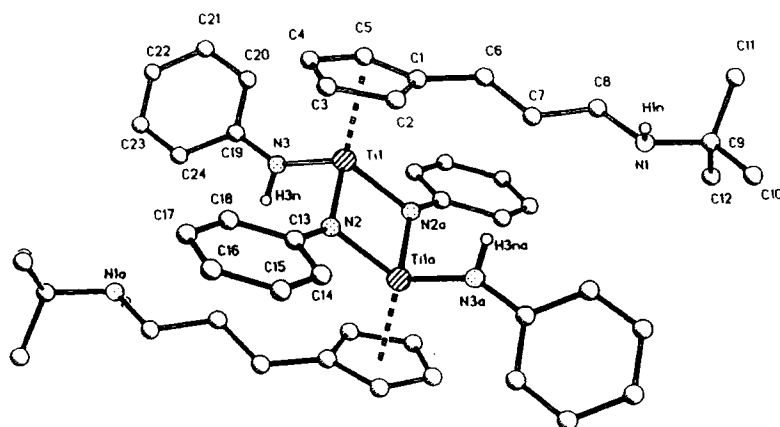

B1: Procedure

The X-ray structure of **4.8** was determined at the University of Durham by Mr P. Ford. A red-brown crystal (0.2 x 0.1 x 0.1 mm) of **4.8** was selected in a perfluorinated oil and mounted at 150K on a glass filament in a Siemens SMART diffractometer equipped with a dry N₂ stream low temperature device. Lattice parameters were obtained by least squares refinement of 25 high angle reflections. A graphite monochromator, $\lambda = 0.71073$ Å, MoK α was used. Data were collected at room temperature, using omega scans. All computation used SHELXTL¹, data reduction and corrections were by XPREP. 16296 reflections were collected with 11067 reflections independent [R(int) = 0.0877] and 10912 reflections with $I > 2\sigma(I)$ used for refinement. The structure was solved by direct methods using XS and refined by Fourier and least-squares using XL. Fourier difference maps indicated which Ti-bound N atoms bore hydrogens but these were placed geometrically along with other hydrogens and refined isotropically. Tables of atomic co-ordinates, thermal parameters and bond lengths and angle have been deposited at the Cambridge Crystallographic Data Centre.

B2: Crystal data and structure refinement

| | | |
|--------------------------------------|---|------------------------------|
| Temperature | 293(2) K | |
| Wavelength | 0.71072 Å | |
| Crystal system | Triclinic | |
| Space group | P1 | |
| Unit cell dimensions | $a = 11.57050(10)$ Å | $\alpha = 78.3580(10)^\circ$ |
| | $b = 12.0315(2)$ Å | $\beta = 83.0390(10)^\circ$ |
| | $c = 17.2718(3)$ Å | $\gamma = 67.9640(10)^\circ$ |
| Volume | 2180.18(6) Å ³ | |
| Z | 2 | |
| Density (calc) | 1.247 Mg m ⁻³ | |
| Absorption coefficient | 0.406 mm ⁻¹ | |
| F(000) | 872 | |
| θ range for data collection | 3.46 - 34.56° | |
| Index ranges | $-18 \leq h \leq 11, -18 \leq k \leq 13, 22 \leq l \leq 24$ | |
| Reflections collected | 16296 | |
| Independent reflections | 11067 [R(int) = 0.0877] | |
| Refinement method | Full-matrix-least-squares on F ² | |
| Data / restraints / parameters | 19012 / 0 / 175 | |
| Goodness-of-fit on F ² | 1.116 | |
| Final R indices [I > 2 σ (I)] | R ₁ = 0.0647, wR ₂ = 0.1615 | |
| R indices (all data) | R ₁ = 0.0880, wR ₂ = 0.2183 | |
| Largest diff. peak and hole | +0.677 and -0.929 eÅ ⁻³ | |

B3: Tables of data

Table B.1: Atomic co-ordinates ($\times 10^4$) and equivalent isotropic displacement parameters

($\text{\AA}^2 \times 10^{-3}$) for 4.8. $U(\text{eq})$ is defined as one third of the trace of the orthogonalised U_{ij} tensor.

| | x | y | z | $U(\text{eq})$ | | | | | |
|-------|----------|----------|----------|----------------|-------|----------|----------|----------|--------|
| Ti(1) | 9305(1) | 5753(1) | 4331(1) | 27(1) | C(39) | 7448(3) | 13537(3) | 1241(2) | 45(1) |
| Ti(2) | 10715(1) | 9145(1) | 629(1) | 26(1) | C(9) | 7111(4) | 339(3) | 6043(2) | 48(1) |
| N(5) | 9724(2) | 10822(2) | 468(1) | 28(1) | C(47) | 15367(3) | 8700(4) | 1419(2) | 50(1) |
| N(3) | 9032(3) | 7474(2) | 4315(2) | 35(1) | C(35) | 5259(4) | 7843(3) | -1436(3) | 54(1) |
| N(2) | 11020(2) | 4926(2) | 4549(1) | 30(1) | C(45) | 15204(3) | 6768(3) | 1496(2) | 47(1) |
| N(6) | 12420(2) | 9159(2) | 534(2) | 35(1) | C(46) | 15844(3) | 7436(4) | 1658(2) | 49(1) |
| N(4) | 6889(3) | 7409(2) | -553(2) | 37(1) | C(21) | 6829(3) | 10242(3) | 3148(2) | 50(1) |
| C(37) | 9176(3) | 11764(2) | 913(2) | 27(1) | C(10) | 8070(5) | -960(4) | 6210(3) | 64(1) |
| C(43) | 13578(3) | 8586(3) | 890(2) | 33(1) | C(11) | 6053(4) | 310(4) | 5594(3) | 64(1) |
| C(13) | 12166(3) | 4629(2) | 4113(2) | 29(1) | C(36) | 7456(4) | 6571(4) | -1789(2) | 53(1) |
| C(18) | 12424(3) | 5533(3) | 3536(2) | 36(1) | C(12) | 6610(8) | 806(5) | 6812(3) | 103(2) |
| C(19) | 8488(3) | 8665(2) | 3917(2) | 33(1) | | | | | |
| C(26) | 9175(3) | 8590(3) | 1460(2) | 35(1) | | | | | |
| C(31) | 8424(3) | 7435(3) | 282(2) | 34(1) | | | | | |
| C(29) | 11164(3) | 7197(2) | 1478(2) | 34(1) | | | | | |
| C(42) | 9881(3) | 11930(3) | 1461(2) | 33(1) | | | | | |
| C(30) | 9620(3) | 6742(3) | 727(2) | 35(1) | | | | | |
| C(25) | 9973(3) | 7500(2) | 1187(2) | 32(1) | | | | | |
| N(1) | 7794(3) | 1081(3) | 5559(2) | 44(1) | | | | | |
| C(14) | 13093(3) | 3457(3) | 4235(2) | 35(1) | | | | | |
| C(3) | 9657(3) | 5238(3) | 3056(2) | 40(1) | | | | | |
| C(4) | 8636(3) | 6330(3) | 3013(2) | 40(1) | | | | | |
| C(38) | 7939(3) | 12582(3) | 818(2) | 37(1) | | | | | |
| C(5) | 7643(3) | 6108(3) | 3500(2) | 40(1) | | | | | |
| C(32) | 8043(3) | 6648(3) | -146(2) | 38(1) | | | | | |
| C(34) | 6208(3) | 5713(3) | -716(2) | 44(1) | | | | | |
| C(41) | 9369(3) | 12897(3) | 1877(2) | 40(1) | | | | | |
| C(24) | 9082(3) | 9510(3) | 3854(2) | 38(1) | | | | | |
| C(33) | 6475(3) | 6866(3) | -1111(2) | 39(1) | | | | | |
| C(27) | 9875(3) | 8925(3) | 1933(2) | 39(1) | | | | | |
| C(40) | 8159(3) | 13706(3) | 1771(2) | 42(1) | | | | | |
| C(23) | 8551(4) | 10689(3) | 3445(2) | 44(1) | | | | | |
| C(28) | 11098(3) | 8068(3) | 1945(2) | 39(1) | | | | | |
| C(1) | 8048(3) | 4859(3) | 3845(2) | 39(1) | | | | | |
| C(7) | 7918(3) | 2975(3) | 4793(2) | 44(1) | | | | | |
| C(20) | 7342(3) | 9063(3) | 3568(2) | 43(1) | | | | | |
| C(2) | 9300(3) | 4322(3) | 3578(2) | 39(1) | | | | | |
| C(22) | 7438(4) | 11062(3) | 3088(2) | 48(1) | | | | | |
| C(17) | 13568(3) | 5268(3) | 3118(2) | 43(1) | | | | | |
| C(16) | 14476(3) | 4112(3) | 3243(2) | 42(1) | | | | | |
| C(44) | 14089(3) | 7319(3) | 1107(2) | 42(1) | | | | | |
| C(48) | 14248(3) | 9270(3) | 1040(2) | 41(1) | | | | | |
| C(15) | 14227(3) | 3204(3) | 3803(2) | 43(1) | | | | | |
| C(6) | 7215(3) | 4244(3) | 4351(2) | 46(1) | | | | | |
| C(8) | 7052(4) | 2345(3) | 5232(2) | 48(1) | | | | | |

Table B1

Table B.2: Hydrogen co-ordinates ($\times 10^4$) and isotropic displacement parameters ($\text{\AA}^2 \times 10^{-3}$)

for 4.8.

| | x | y | z | U(eq) | | | | | |
|--------|-----------|----------|----------|--------|--------|----------|----------|----------|---------|
| H(3N) | 9651(35) | 7412(33) | 4578(23) | 41 | H(35B) | 4959(4) | 7547(3) | -1816(3) | 68(13) |
| H(6N) | 12357(34) | 9887(35) | 292(22) | 42 | H(35C) | 5415(4) | 8566(3) | -1685(3) | 76(14) |
| H(4N) | 6269(36) | 7602(34) | -160(24) | 45 | H(45A) | 15518(3) | 5927(3) | 1648(2) | 59(12) |
| H(18A) | 11823(3) | 6311(3) | 3437(2) | 38(8) | H(46A) | 16583(3) | 7060(4) | 1923(2) | 80(15) |
| H(26A) | 8272(3) | 8973(3) | 1399(2) | 51(10) | H(21A) | 6076(3) | 10482(3) | 2908(2) | 54(11) |
| H(31A) | 7751(3) | 7785(3) | 655(2) | 39(9) | H(10A) | 8383(5) | -1250(4) | 5719(3) | 88(18) |
| H(31B) | 8540(3) | 8099(3) | -102(2) | 27(7) | H(10B) | 7680(5) | -1482(4) | 6535(3) | 61(13) |
| H(29A) | 11891(3) | 6462(2) | 1415(2) | 42(9) | H(10C) | 8749(5) | -962(4) | 6481(3) | 81(16) |
| H(42A) | 10695(3) | 11390(3) | 1546(2) | 28(7) | H(11A) | 6391(4) | 9(4) | 5110(3) | 115(21) |
| H(30A) | 9517(3) | 6053(3) | 1090(2) | 30(7) | H(11B) | 5445(4) | 1118(4) | 5477(3) | 83(16) |
| H(30B) | 10300(3) | 6426(3) | 349(2) | 33(8) | H(11C) | 5663(4) | -214(4) | 5916(3) | 95(17) |
| H(1N) | 8221(38) | 707(37) | 5152(26) | 52 | H(36A) | 8216(4) | 5962(4) | -1585(2) | 74(15) |
| H(14A) | 12943(3) | 2846(3) | 4610(2) | 48(10) | H(36B) | 7612(4) | 7294(4) | -2039(2) | 73(14) |
| H(3A) | 10437(3) | 5099(3) | 2730(2) | 64(13) | H(36C) | 7159(4) | 6273(4) | -2169(2) | 74(14) |
| H(4A) | 8583(3) | 7093(3) | 2659(2) | 63(12) | H(12A) | 6011(8) | 1619(5) | 6703(3) | 91(18) |
| H(38A) | 7447(3) | 12482(3) | 469(2) | 36(8) | H(12B) | 7285(8) | 807(5) | 7085(3) | 92(19) |
| H(5A) | 6792(3) | 6698(3) | 3546(2) | 37(8) | H(12C) | 6216(8) | 288(5) | 7138(3) | 98(18) |
| H(32A) | 8702(3) | 6299(3) | -528(2) | 33(8) | | | | | |
| H(32B) | 7905(3) | 5988(3) | 231(2) | 22(6) | | | | | |
| H(34A) | 5590(3) | 5902(3) | -290(2) | 53(11) | | | | | |
| H(34B) | 6963(3) | 5095(3) | -511(2) | 53(11) | | | | | |
| H(34C) | 5906(3) | 5424(3) | -1099(2) | 54(11) | | | | | |
| H(41A) | 9849(3) | 13000(3) | 2232(2) | 48(10) | | | | | |
| H(24A) | 9838(3) | 9278(3) | 4089(2) | 50(10) | | | | | |
| H(27A) | 9533(3) | 9570(3) | 2256(2) | 71(14) | | | | | |
| H(40A) | 7825(3) | 14353(3) | 2049(2) | 65(13) | | | | | |
| H(23A) | 8957(4) | 11235(3) | 3412(2) | 53(11) | | | | | |
| H(28A) | 11759(3) | 8023(3) | 2268(2) | 43(9) | | | | | |
| H(7A) | 8460(3) | 2483(3) | 4418(2) | 35(8) | | | | | |
| H(7B) | 8441(3) | 3037(3) | 5169(2) | 42(9) | | | | | |
| H(20A) | 6913(3) | 8533(3) | 3616(2) | 41(9) | | | | | |
| H(2A) | 9800(3) | 3450(3) | 3673(2) | 56(11) | | | | | |
| H(22A) | 7096(4) | 11849(3) | 2810(2) | 54(11) | | | | | |
| H(17A) | 13729(3) | 5876(3) | 2746(2) | 64(12) | | | | | |
| H(16A) | 15240(3) | 3943(3) | 2958(2) | 39(9) | | | | | |
| H(44A) | 13682(3) | 6841(3) | 990(2) | 46(10) | | | | | |
| H(48A) | 13943(3) | 10110(3) | 884(2) | 58(12) | | | | | |
| H(15A) | 14827(3) | 2424(3) | 3888(2) | 52(10) | | | | | |
| H(6A) | 6634(3) | 4187(3) | 4014(2) | 65(13) | | | | | |
| H(6B) | 6731(3) | 4752(3) | 4734(2) | 76(15) | | | | | |
| H(8A) | 6584(4) | 2771(3) | 5657(2) | 60(12) | | | | | |
| H(8B) | 6463(4) | 2357(3) | 4873(2) | 51(10) | | | | | |
| H(39A) | 6630(3) | 14073(3) | 1170(2) | 63(12) | | | | | |
| H(47A) | 15804(3) | 9165(4) | 1515(2) | 55(11) | | | | | |
| H(35A) | 4643(4) | 8028(3) | -1008(3) | 40(9) | | | | | |

Table B.2

Table B.3: Bond lengths (Å) for 4.8

| | | | |
|---------------|-----------|---------------|-----------|
| Ti(1)-N(2) | 1.902(2) | Ti(1)-N(3) | 1.969(2) |
| Ti(1)-N(2)#1 | 1.991(2) | Ti(1)-C(3) | 2.356(3) |
| Ti(1)-C(2) | 2.361(3) | Ti(1)-C(4) | 2.377(3) |
| Ti(1)-C(5) | 2.398(3) | Ti(1)-C(1) | 2.412(3) |
| Ti(1)-Ti(1)#1 | 2.8688(9) | Ti(2)-N(5) | 1.891(2) |
| Ti(2)-N(6) | 1.967(3) | Ti(2)-N(5)#2 | 2.008(2) |
| Ti(2)-C(27) | 2.348(3) | Ti(2)-C(26) | 2.359(3) |
| Ti(2)-C(28) | 2.381(3) | Ti(2)-C(29) | 2.408(3) |
| Ti(2)-C(25) | 2.426(3) | Ti(2)-Ti(2)#2 | 2.8633(9) |
| N(5)-C(37) | 1.405(3) | N(5)-Ti(2)#2 | 2.008(2) |
| N(3)-C(19) | 1.397(3) | N(2)-C(13) | 1.402(4) |
| N(2)-Ti(1)#1 | 1.991(2) | N(6)-C(43) | 1.408(4) |
| N(4)-C(32) | 1.471(4) | N(4)-C(33) | 1.480(4) |
| C(37)-C(38) | 1.407(4) | C(37)-C(42) | 1.410(4) |
| C(43)-C(48) | 1.399(4) | C(43)-C(44) | 1.401(4) |
| C(13)-C(14) | 1.408(4) | C(13)-C(18) | 1.414(4) |
| C(18)-C(17) | 1.385(4) | C(19)-C(20) | 1.398(5) |
| C(19)-C(24) | 1.407(4) | C(26)-C(27) | 1.422(4) |
| C(26)-C(25) | 1.425(4) | C(31)-C(32) | 1.520(4) |
| C(31)-C(30) | 1.528(4) | C(29)-C(25) | 1.416(4) |
| C(29)-C(28) | 1.420(4) | C(42)-C(41) | 1.391(4) |
| C(30)-C(25) | 1.510(4) | N(1)-C(8) | 1.470(4) |
| N(1)-C(9) | 1.480(4) | C(14)-C(15) | 1.388(5) |
| C(3)-C(4) | 1.395(5) | C(3)-C(2) | 1.431(4) |
| C(4)-C(5) | 1.416(5) | C(38)-C(39) | 1.388(4) |
| C(5)-C(1) | 1.418(4) | C(34)-C(33) | 1.540(4) |
| C(41)-C(40) | 1.381(5) | C(24)-C(23) | 1.391(4) |
| C(33)-C(36) | 1.526(5) | C(33)-C(35) | 1.536(5) |
| C(27)-C(28) | 1.404(5) | C(40)-C(39) | 1.392(5) |
| C(23)-C(22) | 1.374(6) | C(1)-C(2) | 1.408(5) |
| C(1)-C(6) | 1.520(4) | C(7)-C(8) | 1.520(4) |
| C(7)-C(6) | 1.524(5) | C(20)-C(21) | 1.395(4) |
| C(22)-C(21) | 1.394(5) | C(17)-C(16) | 1.387(5) |
| C(16)-C(15) | 1.398(5) | C(44)-C(45) | 1.394(5) |
| C(48)-C(47) | 1.391(5) | C(9)-C(12) | 1.513(6) |
| C(9)-C(10) | 1.533(6) | C(9)-C(11) | 1.540(6) |
| C(47)-C(46) | 1.400(5) | C(45)-C(46) | 1.365(5) |

Table B.3

Table B.4: Bond angles (°) for 4.8.

| | | | | | | | |
|----------------------|------------|---------------------|------------|-------------------|----------|-------------------|----------|
| N(2)-Ti(1)-N(3) | 103.89(10) | N(2)-Ti(1)-N(2)#1 | 85.08(10) | C(48)-C(43)-C(44) | 118.1(3) | C(48)-C(43)-N(6) | 120.8(3) |
| N(3)-Ti(1)-N(2)#1 | 106.06(10) | N(2)-Ti(1)-C(3) | 91.70(11) | C(44)-C(43)-N(6) | 121.1(3) | N(2)-C(13)-C(14) | 122.4(2) |
| N(3)-Ti(1)-C(3) | 112.76(11) | N(2)#1-Ti(1)-C(3) | 140.64(10) | N(2)-C(13)-C(18) | 119.6(3) | C(14)-C(13)-C(18) | 118.0(3) |
| N(2)-Ti(1)-C(2) | 93.17(11) | N(3)-Ti(1)-C(2) | 145.09(11) | C(17)-C(18)-C(13) | 120.4(3) | N(3)-C(19)-C(20) | 121.6(3) |
| N(2)#1-Ti(1)-C(2) | 105.57(10) | C(3)-Ti(1)-C(2) | 35.33(11) | N(3)-C(19)-C(24) | 120.8(3) | C(20)-C(19)-C(24) | 117.5(3) |
| N(2)-Ti(1)-C(4) | 121.33(11) | N(3)-Ti(1)-C(4) | 87.57(11) | C(27)-C(26)-C(25) | 108.3(3) | C(27)-C(26)-Ti(2) | 72.0(2) |
| N(2)-Ti(1)-C(4) | 147.02(11) | C(3)-Ti(1)-C(5) | 34.28(12) | C(25)-C(26)-Ti(2) | 75.3(2) | C(32)-C(31)-C(30) | 113.6(2) |
| N(2)#1-Ti(1)-C(4) | 57.65(11) | N(2)-Ti(1)-C(5) | 147.75(11) | C(25)-C(29)-C(28) | 108.8(3) | C(25)-C(29)-Ti(2) | 73.7(2) |
| C(2)-Ti(1)-C(5) | 96.74(11) | C(2)-Ti(1)-C(5) | 112.86(10) | C(28)-C(29)-Ti(2) | 71.7(2) | C(41)-C(42)-C(37) | 120.4(3) |
| C(3)-Ti(1)-C(5) | 57.18(12) | N(2)#1-Ti(1)-C(5) | 57.05(12) | C(25)-C(30)-C(31) | 114.1(2) | C(29)-C(25)-C(26) | 106.9(3) |
| C(4)-Ti(1)-C(5) | 34.49(11) | N(2)-Ti(1)-C(1) | 124.06(11) | C(29)-C(25)-C(30) | 125.4(3) | C(26)-C(25)-C(30) | 127.5(3) |
| N(3)-Ti(1)-C(1) | 130.05(11) | N(2)#1-Ti(1)-C(1) | 92.21(10) | C(29)-C(25)-Ti(2) | 72.3(2) | C(26)-C(25)-Ti(2) | 70.1(2) |
| C(3)-Ti(1)-C(1) | 57.75(11) | C(2)-Ti(1)-C(1) | 34.31(12) | C(30)-C(25)-Ti(2) | 126.1(2) | C(8)-N(1)-C(9) | 117.0(3) |
| C(4)-Ti(1)-C(1) | 57.47(10) | C(5)-Ti(1)-C(1) | 34.29(10) | C(15)-C(14)-C(13) | 120.7(3) | C(4)-C(3)-C(2) | 107.8(3) |
| N(2)-Ti(1)-Ti(1)#1 | 43.74(7) | N(3)-Ti(1)-Ti(1)#1 | 110.55(8) | C(4)-C(3)-Ti(1) | 73.7(2) | C(2)-C(3)-Ti(1) | 72.5(2) |
| N(2)#1-Ti(1)-Ti(1)#1 | 41.34(7) | C(3)-Ti(1)-Ti(1)#1 | 123.80(9) | C(3)-C(4)-C(5) | 108.1(3) | C(3)-C(4)-Ti(1) | 72.0(2) |
| C(2)-Ti(1)-Ti(1)#1 | 102.88(8) | C(4)-Ti(1)-Ti(1)#1 | 157.94(9) | C(5)-C(4)-Ti(1) | 73.6(2) | C(39)-C(38)-C(37) | 120.4(3) |
| C(5)-Ti(1)-Ti(1)#1 | 146.12(8) | C(1)-Ti(1)-Ti(1)#1 | 113.46(7) | C(4)-C(5)-C(1) | 108.7(3) | C(4)-C(5)-Ti(1) | 71.9(2) |
| N(5)-Ti(2)-N(6) | 102.53(10) | N(5)-Ti(2)-N(5)#2 | 85.57(10) | C(1)-C(5)-Ti(1) | 73.4(2) | N(4)-C(32)-C(31) | 108.7(2) |
| N(6)-Ti(2)-N(5)#2 | 106.41(10) | N(5)-Ti(2)-C(27) | 90.17(10) | C(40)-C(41)-C(42) | 121.1(3) | C(23)-C(24)-C(19) | 120.8(3) |
| N(6)-Ti(2)-C(27) | 114.54(11) | N(5)#2-Ti(2)-C(27) | 138.75(11) | N(4)-C(33)-C(36) | 109.7(3) | N(4)-C(33)-C(35) | 105.9(3) |
| N(5)-Ti(2)-C(26) | 93.61(10) | N(6)-Ti(2)-C(26) | 146.33(10) | C(36)-C(33)-C(35) | 109.6(3) | N(4)-C(33)-C(34) | 113.1(3) |
| N(5)#2-Ti(2)-C(26) | 104.12(10) | C(27)-Ti(2)-C(26) | 35.17(11) | C(36)-C(33)-C(34) | 109.7(3) | C(35)-C(33)-C(34) | 108.8(3) |
| N(5)-Ti(2)-C(28) | 119.13(11) | N(6)-Ti(2)-C(28) | 88.63(11) | C(28)-C(27)-C(26) | 108.2(3) | C(28)-C(27)-Ti(2) | 74.0(2) |
| N(5)#2-Ti(2)-C(28) | 148.08(10) | C(27)-Ti(2)-C(28) | 34.54(12) | C(26)-C(27)-Ti(2) | 72.8(2) | C(41)-C(40)-C(39) | 118.8(3) |
| C(26)-Ti(2)-C(28) | 57.74(11) | N(5)-Ti(2)-C(29) | 147.05(10) | C(22)-C(23)-C(24) | 121.2(3) | C(27)-C(28)-C(29) | 107.8(3) |
| N(6)-Ti(2)-C(29) | 96.81(10) | N(5)#2-Ti(2)-C(29) | 114.27(9) | C(27)-C(28)-Ti(2) | 71.4(2) | C(29)-C(28)-Ti(2) | 73.8(2) |
| C(27)-Ti(2)-C(29) | 57.36(11) | C(26)-Ti(2)-C(29) | 57.20(11) | C(2)-C(1)-C(5) | 107.1(3) | C(2)-C(1)-C(6) | 128.3(3) |
| C(28)-Ti(2)-C(29) | 34.50(10) | N(5)-Ti(2)-C(25) | 125.67(10) | C(5)-C(1)-C(6) | 124.5(3) | C(2)-C(1)-Ti(1) | 70.9(2) |
| N(6)-Ti(2)-C(25) | 129.58(10) | N(5)#2-Ti(2)-C(25) | 92.42(9) | C(5)-C(1)-Ti(1) | 72.3(2) | C(6)-C(1)-Ti(1) | 125.6(2) |
| C(27)-Ti(2)-C(25) | 57.77(10) | C(26)-Ti(2)-C(25) | 34.62(10) | C(8)-C(7)-C(6) | 112.7(3) | C(21)-C(20)-C(19) | 121.1(3) |
| N(5)-Ti(2)-C(25) | 57.33(10) | C(29)-Ti(2)-C(25) | 34.06(9) | C(1)-C(2)-C(3) | 108.4(3) | C(1)-C(2)-Ti(1) | 74.8(2) |
| N(5)-Ti(2)-Ti(2)#2 | 44.37(7) | N(6)-Ti(2)-Ti(2)#2 | 109.97(7) | C(3)-C(2)-Ti(1) | 72.1(2) | C(23)-C(22)-C(21) | 119.0(3) |
| N(5)#2-Ti(2)-Ti(2)#2 | 41.19(6) | C(27)-Ti(2)-Ti(2)#2 | 121.96(9) | C(18)-C(17)-C(16) | 121.1(3) | C(17)-C(16)-C(15) | 119.1(3) |
| C(26)-Ti(2)-Ti(2)#2 | 102.28(8) | C(28)-Ti(2)-Ti(2)#2 | 156.48(9) | C(45)-C(44)-C(43) | 120.5(3) | C(47)-C(48)-C(43) | 120.4(3) |
| C(29)-Ti(2)-Ti(2)#2 | 147.42(7) | C(25)-Ti(2)-Ti(2)#2 | 114.51(7) | C(14)-C(15)-C(16) | 120.6(3) | C(1)-C(6)-C(7) | 114.3(3) |
| C(37)-N(5)-Ti(2) | 138.8(2) | C(37)-N(5)-Ti(2)#2 | 125.6(2) | N(1)-C(8)-C(7) | 109.3(3) | C(38)-C(39)-C(40) | 121.2(3) |
| Ti(2)-N(5)-Ti(2)#2 | 94.43(10) | C(19)-N(3)-Ti(1) | 145.2(2) | N(1)-C(9)-C(12) | 109.9(3) | N(1)-C(9)-C(10) | 105.9(3) |
| C(13)-N(2)-Ti(1) | 136.9(2) | C(13)-N(2)-Ti(1)#1 | 127.3(2) | C(12)-C(9)-C(10) | 110.0(4) | N(1)-C(9)-C(11) | 112.1(3) |
| Ti(1)-N(2)-Ti(1)#1 | 94.92(10) | C(43)-N(6)-Ti(2) | 141.7(2) | C(12)-C(9)-C(11) | 110.8(4) | C(10)-C(9)-C(11) | 108.0(3) |
| C(32)-N(4)-C(33) | 117.2(2) | N(5)-C(37)-C(38) | 122.0(2) | C(48)-C(47)-C(46) | 120.8(3) | C(46)-C(45)-C(44) | 121.4(3) |
| N(5)-C(37)-C(42) | 119.9(2) | C(38)-C(37)-C(42) | 118.1(3) | C(45)-C(46)-C(47) | 118.7(3) | C(22)-C(21)-C(20) | 120.4(3) |

Table B.4: Bond angles (°) for 4.8

Table B.5: Anisotropic displacement parameters ($\text{\AA}^2 \times 10^{-3}$) for 4.8. The anisotropic

displacement factor takes the form $-2\pi^2[h^2a^{*2} U_{11} + \dots + 2hka^*b^* U_{12}]$

| | U11 | U22 | U33 | U23 | U13 | U12 |
|-------|--------|-------|-------|--------|--------|--------|
| Ti(1) | 35(1) | 23(1) | 22(1) | -1(1) | -7(1) | -10(1) |
| Ti(2) | 34(1) | 22(1) | 23(1) | -2(1) | -6(1) | -9(1) |
| N(5) | 38(1) | 23(1) | 26(1) | -5(1) | -4(1) | -11(1) |
| N(3) | 46(1) | 26(1) | 31(1) | 0(1) | -10(1) | -12(1) |
| N(2) | 39(1) | 22(1) | 28(1) | -2(1) | -6(1) | -12(1) |
| N(6) | 40(1) | 28(1) | 36(1) | 2(1) | -15(1) | -12(1) |
| N(4) | 45(1) | 30(1) | 40(1) | -3(1) | -12(1) | -15(1) |
| C(37) | 36(1) | 23(1) | 24(1) | -4(1) | -3(1) | -10(1) |
| C(43) | 36(1) | 30(1) | 30(1) | -5(1) | -5(1) | -10(1) |
| C(13) | 35(1) | 28(1) | 25(1) | -3(1) | -6(1) | -12(1) |
| C(18) | 44(2) | 30(1) | 31(1) | -1(1) | -3(1) | -13(1) |
| C(19) | 42(2) | 24(1) | 28(1) | -2(1) | -1(1) | -8(1) |
| C(26) | 41(2) | 33(1) | 29(1) | -3(1) | 0(1) | -15(1) |
| C(31) | 39(2) | 30(1) | 34(1) | -5(1) | -4(1) | -15(1) |
| C(29) | 41(2) | 24(1) | 33(1) | 4(1) | -12(1) | -11(1) |
| C(42) | 40(2) | 30(1) | 30(1) | -7(1) | -5(1) | -12(1) |
| C(30) | 47(2) | 26(1) | 34(1) | -2(1) | -11(1) | -16(1) |
| C(25) | 43(2) | 25(1) | 27(1) | 1(1) | -9(1) | -14(1) |
| N(1) | 57(2) | 39(1) | 41(2) | -4(1) | -3(1) | -26(1) |
| C(14) | 40(2) | 28(1) | 34(1) | -2(1) | -7(1) | -9(1) |
| C(3) | 58(2) | 42(2) | 23(1) | -7(1) | -5(1) | -21(2) |
| C(4) | 56(2) | 43(2) | 25(1) | 3(1) | -15(1) | -22(2) |
| C(38) | 39(2) | 33(1) | 35(2) | -6(1) | -8(1) | -8(1) |
| C(5) | 47(2) | 41(2) | 34(2) | 3(1) | -16(1) | -19(1) |
| C(32) | 49(2) | 29(1) | 40(2) | -3(1) | -13(1) | -18(1) |
| C(34) | 52(2) | 32(2) | 52(2) | -5(1) | -10(2) | -20(1) |
| C(41) | 55(2) | 39(2) | 34(2) | -13(1) | -3(1) | -22(1) |
| C(24) | 53(2) | 29(1) | 33(2) | -7(1) | -2(1) | -15(1) |
| C(33) | 46(2) | 33(2) | 40(2) | -3(1) | -11(1) | -18(1) |
| C(27) | 61(2) | 35(2) | 23(1) | -3(1) | -2(1) | -21(1) |
| C(40) | 55(2) | 28(1) | 40(2) | -12(1) | 2(1) | -10(1) |
| C(23) | 66(2) | 28(1) | 37(2) | -8(1) | 7(2) | -20(2) |
| C(28) | 59(2) | 36(2) | 27(1) | 3(1) | -14(1) | -22(1) |
| C(1) | 54(2) | 39(2) | 33(2) | -2(1) | -14(1) | -26(1) |
| C(7) | 57(2) | 37(2) | 46(2) | -5(1) | -6(2) | -26(2) |
| C(20) | 42(2) | 33(2) | 48(2) | 0(1) | -6(1) | -9(1) |
| C(2) | 58(2) | 34(2) | 31(1) | -9(1) | -9(1) | -19(1) |
| C(22) | 60(2) | 26(2) | 42(2) | 1(1) | 2(2) | -3(1) |
| C(17) | 49(2) | 46(2) | 36(2) | -2(1) | 1(1) | -24(2) |
| C(16) | 35(2) | 53(2) | 41(2) | -14(1) | 2(1) | -15(1) |
| C(44) | 44(2) | 29(1) | 49(2) | -3(1) | -5(1) | -12(1) |
| C(48) | 41(2) | 31(2) | 52(2) | -8(1) | -8(1) | -12(1) |
| C(15) | 41(2) | 39(2) | 46(2) | -9(1) | -7(1) | -8(1) |
| C(6) | 54(2) | 45(2) | 47(2) | 3(1) | -17(2) | -29(2) |
| C(8) | 57(2) | 42(2) | 53(2) | 0(2) | -10(2) | -29(2) |
| C(39) | 48(2) | 32(2) | 45(2) | -12(1) | -5(1) | -1(1) |
| C(9) | 70(2) | 45(2) | 40(2) | -6(1) | 5(2) | -34(2) |
| C(47) | 41(2) | 57(2) | 55(2) | -20(2) | -9(2) | -15(2) |
| C(35) | 59(2) | 39(2) | 67(2) | 1(2) | -29(2) | -17(2) |
| C(45) | 42(2) | 34(2) | 49(2) | 8(1) | -1(1) | -4(1) |
| C(46) | 35(2) | 63(2) | 38(2) | -4(2) | -9(1) | -4(2) |
| C(21) | 45(2) | 38(2) | 51(2) | 3(1) | -8(2) | -2(2) |
| C(10) | 85(3) | 49(2) | 62(3) | 7(2) | -14(2) | -37(2) |
| C(11) | 57(2) | 51(2) | 88(3) | -3(2) | -2(2) | -30(2) |
| C(36) | 64(2) | 67(2) | 38(2) | -10(2) | -7(2) | -32(2) |
| C(12) | 192(7) | 86(4) | 54(3) | -29(3) | 42(4) | -84(5) |

Table B.5

B6: Reference

- 1) Siemens SHELXTL, Version 5.03, Siemens Analytical Instruments.

Appendix C: Departmental Colloquia Attended

1993-94

- October 4 Prof. F.J. Feher, University of California, Irvine, USA
"Bridging the Gap between Surfaces and Solution with Sessilquioxanes"
- October 20 Dr. P. Quayle, University of Manchester
"Aspects of Aqueous ROMP Chemistry"
- October 21 Prof. R. Adams, University of South Carolina, USA
"Chemistry of Metal Carbonyl Cluster Complexes : Development of Cluster Based Alkyne Hydrogenation Catalysts"
- November 24 Dr. P.G. Bruce, University of St. Andrews
"Structure and Properties of Inorganic Solids and Polymers"
- January 26 Prof. J. Evans, University of Southampton
"Shining Light on Catalysts"
- February 16 Prof. K.H. Theopold, University of Delaware, USA
"Paramagnetic Chromium Alkyls : Synthesis and Reactivity"
- February 23 Prof. P.M. Maitlis, University of Sheffield
"Across the Border : From Homogeneous to Heterogeneous Catalysis"
- March 10 Prof. S.V. Ley, University of Cambridge
"New Methods for Organic Synthesis"
- March 25 Dr. J. Dilworth, University of Essex
"Technetium and Rhenium Compounds with Applications as Imaging Agents"
- April 28 Prof. R. J. Gillespie, McMaster University, Canada
"The Molecular Structure of some Metal Fluorides and Oxofluorides: Apparent Exceptions to the VSEPR Model"

1994-95

- October 5 Prof. N. L. Owen, Brigham Young University, Utah, USA
"Determining Molecular Structure - the INADEQUATE NMR way"
- October 19 Prof. N. Bartlett, University of California
"Some Aspects of Ag(II) and Ag(III) Chemistry"
- November 2 Dr P. G. Edwards, University of Wales, Cardiff
"The Manipulation of Electronic and Structural Diversity in Metal Complexes - New Ligands"
- November 3 Prof. B. F. G. Johnson, Edinburgh University
"Arene-metal Clusters"
- November 9 Dr G. Hogarth, University College, London
"New Vistas in Metal-imido Chemistry"
- November 10 Dr M. Block, Zeneca Pharmaceuticals, Macclesfield
"Large-scale Manufacture of ZD 1542, a Thromboxane Antagonist Synthase Inhibitor"
- February 8 Dr D. O'Hare, Oxford University
"Synthesis and Solid-state Properties of Poly-, Oligo- and Multidecker Metallocenes"
- March 1 Dr M. Rosseinsky, Oxford University
"Fullerene Intercalation Chemistry"
- March 22 Dr M. Taylor, University of Auckland, New Zealand
"Structural Methods in Main-group Chemistry"
- April 26 Dr M. Schroder, University of Edinburgh
"Redox-active Macrocyclic Complexes : Rings, Stacks and Liquid Crystals"

1995-96

- November 15 Dr Andrea Sella, UCL, London
"Chemistry of Lanthanides with Polypyrazolborate Ligands"
- November 29 Prof. Dennis Tuck, University of Windsor, Ontario, Canada
"New Indium Coordination Chemistry"
- February 12 Dr Paul Pringle, University of Bristol
"Catalytic Self-Replication of Phosphines on Platinum(O)"
- February 21 Dr C R Pulham, Univ. Edinburgh
"Heavy Metal Hydrides - an exploration of the chemistry of stannanes and plumbanes"
- February 28 Prof. E. W. Randall, Queen Mary & Westfield College
"New Perspectives in NMR Imaging"
- March 6 Dr Richard Whitby, Univ of Southampton
"New approaches to chiral catalysts: Induction of planar and metal centred asymmetry"
- March 7 Dr D.S. Wright, University of Cambridge
"Synthetic Applications of Me₂N-p-Block Metal Reagents"
- March 13 Prof. Dave Garner, Manchester University
"Mushrooming in Chemistry"

Τελεσται
(Part of John 19:30)

