

2nd Micro and Nano Flows Conference
West London, UK, 1-2 September 2009

Natural Convection Heat Transfer Effects with Micro Finned Structures

Saad MAHMOUD, Raya AL-DADAH*, David ASPINWALL, Leung SOO

* Corresponding author: Tel.: ++44(0)1214143513; Fax: ++44(0)1214143958; Email: r.k.al-dadah@bham.ac.uk

School of Mechanical Engineering, University of Birmingham, Birmingham, B15 2TT, UK

Abstract Micro-scale natural convection plays an important role in heat removal from microelectronic components and Micro-Electro-Mechanical Systems (MEMS) devices. Natural convection of macrofin arrays has been extensively studied by many researchers over the past several decades; however analysis of free convection around microfin arrays is less well researched. The objective of this work was to experimentally investigate the effects of micro fin height and spacing for a horizontally mounted heat sink on heat transfer coefficient when operating under steady state natural convection conditions. An array of micro finned copper heat sinks was fabricated using micro-electro discharge wire machining (μ -EDWM) with fin height ranging from 0.25 to 1.0mm and fin spacing from 0.5 to 1.0mm respectively. Results showed that values of the convective heat transfer coefficient increased with increased fin spacing and decreased as fin height increased.

Keywords: Micro Fins, Natural Convection, Micro Heat Sinks, Micromachining

Nomenclature:

A_i :	Radiation heat transfer area (m^2)
F_{i-k} :	View factor for the fin various surfaces
H :	Fin height (mm)
h_c :	Convective heat transfer coefficient ($Wm^{-2}K^{-1}$)
I :	Electric current (Amps)
k :	Thermal conductivity ($Wm^{-1}K^{-1}$)
L :	Heat sink length (mm)
Nu :	Nusselt number
Q_c :	Convection heat transfer rate (W)
Q_{input} :	Input heat transfer rate (W)
Q_{losses} :	Heat transfer rate loss (W)
Q_r :	Radiative heat transfer rate (W)
Ra :	Rayleigh number
r :	Characteristic length for vertically aligned finned heat sinks (m)
S :	Fin Spacing (mm)
t :	Fin thickness (mm)
t_b :	Fin base thickness (mm)
T_w :	Surface temperature ($^{\circ}C$)
T_a :	Ambient air temperature ($^{\circ}C$)
U :	Uncertainty
V :	Electric voltage (Volts)
W :	Heat sink width (mm)

Greek Symbols

α :	Thermal diffusivity (m^2s^{-1})
β :	Thermal expansion coefficient (K^{-1})
ε :	Emmissivity of copper
ν :	Kinematic viscosity (m^2s^{-1})
σ :	Stefan-Boltzmann ($Wm^{-2}K^{-4}$)

1. Introduction

With the limitations of space and power, micro scale natural convection plays an important role in heat removal mechanisms in many engineering applications e.g. cooling of microelectronic components, micro structured devices and Micro-Electro-Mechanical-System (MEMS) devices based on free convection such as micro machined convective accelerometers [1-4]. Natural convection of macrofin arrays has been extensively studied by many researchers over recent decades [5-9], however analysis of free convection around microfin arrays has not received the necessary attention in line with recent advancements in micro engineering

applications [1, 9]. The larger surface to volume ratios for microstructures and microdevices has meant that parameters relating to surface effects have a greater impact on microscale flow and heat transfer mechanisms. Consequently, viscous forces play a more dominant role than inertia forces in microscale natural convection heat transfer [3]. Also, compressed boundary layers at very small scale play a role in improving convective heat transfer coefficient. Here, experimental results have shown that the values of natural convection heat transfer coefficient for microfabricated heated structures are generally larger than those at macroscale [1, 10]. The objectives of this work were to experimentally investigate the effects of micro fin height and spacing on the natural convection heat transfer coefficient.

2. Experimental Setup

Micro-electro discharge wire machining (μ -EDWM) process employing wires $< 100\mu\text{m}$ diameter was used to fabricate an array of 12 copper test pieces with different fin geometries. Figure 1 shows a schematic for a typical test piece (heat sink) arrangement. Table 1 shows geometry variations for the 12 machined copper test pieces with fin height (H) ranging from 0.25mm to 1mm, and fin spacing (S) ranging from 0.5mm to 1mm respectively. Fin thickness (t) and base thickness (t_b) were kept constant at 1.0mm and 5mm respectively and all test pieces had a square base area with $L = W = 31.75\text{mm}$. Dimensions of test pieces were measured using Wild M3Z microscope with X, Y digital micrometer with $1\mu\text{m}$ resolution. The measured values deviate from the nominal values listed in table 1 by maximum of $\pm 4\%$ in the fin spacing and $\pm 3\%$ in the fin height.

Test pieces were heated from the base using an electrical mat heater of similar surface area capable of supplying up to 10W. The power input to the heater was controlled using a variable output power supply device. In order to

minimise heat leakages from all sides except the top finned surface, the test piece and the mat heater were placed in a 5mm deep square pocket milled on the top face of 100x100x42mm fibreglass (GRP) block with thermal conductivity of $0.04\text{Wm}^{-1}\text{K}^{-1}$. The test piece and the fibreglass block were housed in a 200x230x100mm styropor block with thermal conductivity of $0.032\text{Wm}^{-1}\text{K}^{-1}$. Temperatures were measured using two T type thermocouples placed in two holes 1mm diameter machined at opposite corners at the base of each test piece. Figure 2 shows a general schematic for the experimental set-up.

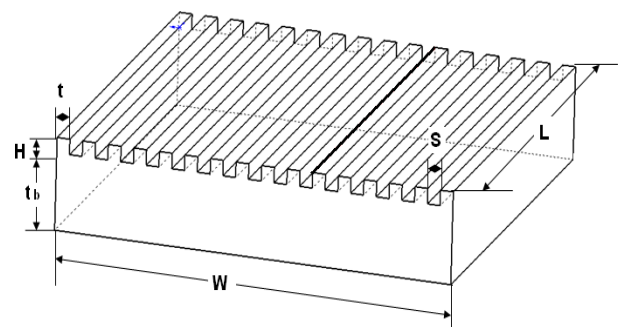

Figure 1: Heat sink geometry

Test piece No.	1	2	3	4
Fin height (H)	0.25	0.5	0.75	1
Fin spacing (S)	0.5	0.5	0.5	0.5
Test piece No.	5	6	7	8
Fin height (H)	0.25	0.5	0.75	1
Fin spacing (S)	0.75	0.75	0.75	0.75
Test piece No.	9	10	11	12
Fin height (H)	0.25	0.5	0.75	1
Fin spacing (S)	1	1	1	1

Table 1: Fin geometry variation, all dimensions are in mm

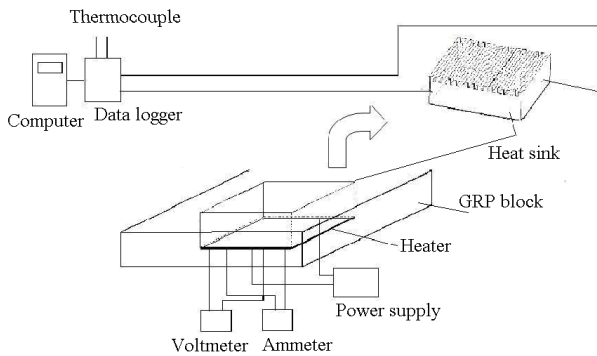

Figure 2: Schematic of the experimental set-up (courtesy of Y. Li)

3. Data Analysis

All test pieces shown in Table 1 were evaluated together with a 31.75x31.75x5mm flat copper plate test piece used for benchmarking. Power input ranged from 0.2 to 1.6W and temperatures were measured at steady state conditions. Steady state conditions were typically reached at around 60 minutes from initiating a power input. Figure 3 shows the two thermocouple transient and steady state temperature readings for test piece with $H=0.5\text{mm}$ and $S=0.75\text{mm}$ as power input increased, together with ambient temperature. The uncertainty in the thermocouples readings is $\pm 0.3^\circ\text{C}$ based on manufacturer data.

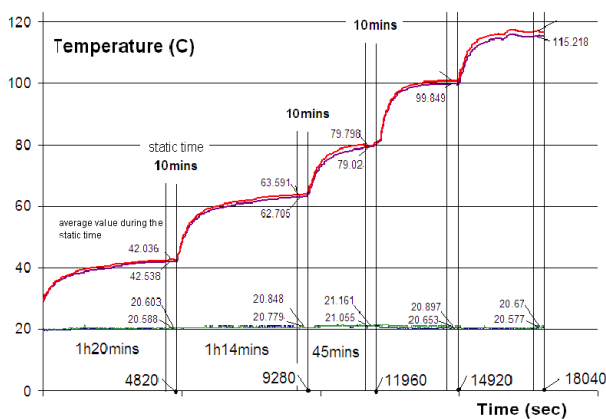

Figure 3: Thermocouples temperatures (test piece $H=0.5\text{mm}$ and $S=0.75\text{mm}$) versus power input

In this set up, the heat input to the test piece was dissipated to the ambient surroundings through radiation and natural convection modes of heat transfer in addition to heat losses from the back of the test piece and the sides through the GRP and the styropor. Therefore, the naturally convected heat can be calculated from:

$$Q_c = Q_{input} - Q_r - Q_{losses} \quad (1)$$

Q_r is the radiated heat transfer calculated using:

$$Q_r = \epsilon \sigma A_i F_{i-k} (T_w^4 - T_a^4) \quad (2)$$

where ϵ is the emissivity of commercially available copper taken from Suryanarayana [11] as 0.15, σ is the Stefan-Boltzmann constant for radiation heat transfer. A_i is area of the relevant fin surface e.g. top, side, face and base. F_{i-k} are the view factors for the various fin surfaces and were calculated using methodology presented by Kulkarni and Das [12]. The radiation heat transfer rate was found to range from 9 to 13% of the total heat input. T_w is the surface temperature as obtained by averaging the two thermocouples readings. T_a is the ambient air temperature. The main uncertainty in evaluating the radiation heat transfer comes from the value of the copper emissivity and is estimated to be $\pm 6\%$ based on published data.

The heat transfer losses through the GRP and the styropor were evaluated as a function of the surface temperatures surrounding the test piece. These losses were found to be less than $\pm 6\%$ of the heat input with uncertainty value ranging from $\pm 0.4\%$ at high temperature difference to $\pm 2.12\%$ at low values.

The power input Q_{input} was measured using an electronic wattmeter model EW604. The readings of the wattmeter were compared to power calculated from supplied current and voltage measurements. The current and voltage were measured at immediate input connections to the heater to eliminate losses in the leads of power supply. An average deviation of $\pm 2\%$ was measured between wattmeter readings and the power calculated by:

$$Q_{input} = V * I \quad (3)$$

The uncertainty of measuring the current is \pm (0.3 percent of the reading plus 0.05 percent of the full scale) as stated by the manufacturer data sheet. The voltmeter is a clamp meter with uncertainty of $\pm 2\%$ of the reading. This lead to an uncertainty of $\pm 2.022\%$ in measuring the power input direct to the heater.

The overall uncertainty in Q_c was evaluated from the uncertainties in Q_{input} , Q_r and Q_{losses} as discusses above. This was found to be a maximum of $\pm 6.7\%$.

The convective heat transfer coefficient was calculated by:

$$h_c = \frac{Q_c}{A_s \times (T_w - T_a)} \quad (4)$$

where A_s is the total surface area of the finned structure.

The uncertainty in the heat transfer coefficient was calculated using equation 5, taking into account the uncertainty in the various terms used in equation 4 with values listed in table 2.

$$\frac{U_{h_c}}{h_c} = \pm \sqrt{\left(\frac{U_{Q_c}}{Q_c}\right)^2 + \left(\frac{U_{A_s}}{A_s}\right)^2 + \left(\frac{U_{T_w}}{T_w - T_a}\right)^2 + \left(\frac{U_{T_a}}{T_w - T_a}\right)^2} \quad (5)$$

Term	Uncertainty
Q_c	$\pm 6.7\%$
A_s	$\pm 5\%$
T_w	0.3K
T_a	0.3K

Table 2: Measurements uncertainty

The uncertainty of the convective heat transfer coefficient is calculated to be a maximum of $\pm 8.6\%$ at the minimum temperature difference used.

4. Results and Discussion

In order to validate the results from the experimental procedure, a flat plate was tested and its results were compared to well established correlations. Figure 4 depicts the Nusselt number versus Rayleigh number for the horizontal flat plate. The results are contrasted with correlations recommended by Martorell et al. [13], Lewandowski et al. [14] and Fujii and Imura [15] as documented in general heat transfer text books e.g. [16]. It can be seen that the flat plate results agree well with the correlation of Fujii and Imura [15]. The correlation recommended by Martorell et al. [13] under-predicted the experimental results while the correlation recommended by Lewandowski et al. [14] over-predicted the experimental results. Here it is worth noting that both the Nusselt and Rayleigh numbers were calculated using the width of the heat transfer surface as the characteristic length. It is clear from the above that the experimental technique employed was valid.

Figure 5 shows the variation of convective heat transfer coefficient versus surface to air temperature differences for the test pieces with $S=0.5\text{mm}$ and the flat plate. It can be seen that the flat plate has the highest heat transfer coefficient. This higher heat transfer coefficient of the flat plate compared to the finned surfaces is consistent with the findings of Kim et al [9].

Figure 6 shows the variation of heat transfer coefficient with fin height for fin spacing of 0.5mm, 0.75mm and 1mm. It can be seen that as the fin height decreases, the heat transfer coefficient increases. This could be explained as follows; as the fin height increases the thickness of the boundary layer increases to be higher than the spacing between the fins. Hence the temperature difference available for driving convection heat transfer will be reduced. The figure also shows that the heat transfer coefficient increases with increasing the fin spacing.

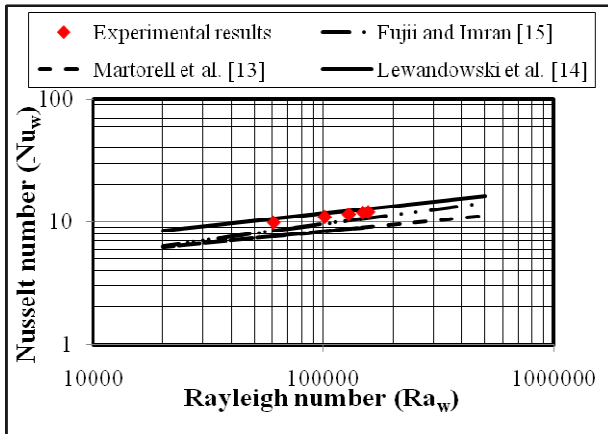

Figure 4: Nusselt number versus Rayleigh number for the horizontal flat plate.

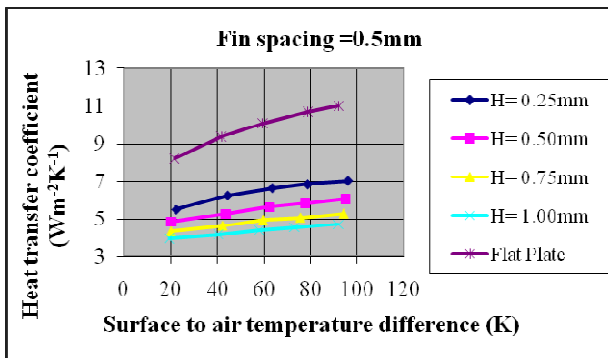

Figure 5: Comparison of flat plate heat transfer coefficient with finned surfaces.

Figure 7 compares the difference in heat transfer coefficient for fin heights of 0.25mm and 1.0mm with heat input at the different fin spacings used. It can be seen that initially the difference in coefficient increases with increasing heat input and then flattens out. Also the difference in heat transfer coefficient increases with increasing fin spacing.

Kim et al. [9] proposed a correlation for heat transfer performance of micro finned surfaces in the form:

$$Nu_r = 1.18 \left[Ra_r \left(\frac{r}{H} \right)^4 \left(\frac{r}{L} \right)^4 \right]^{0.147} \quad (6)$$

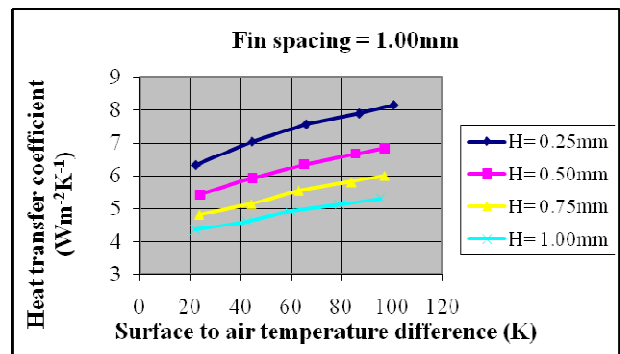
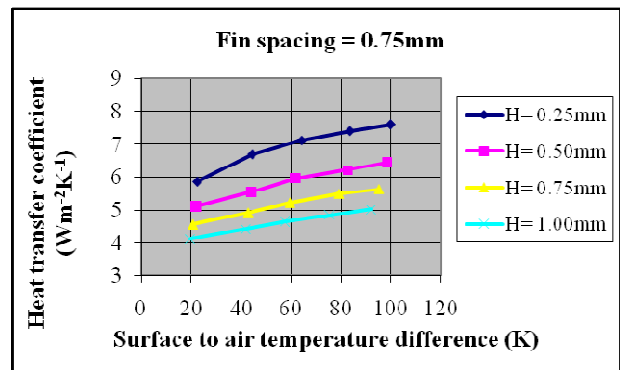
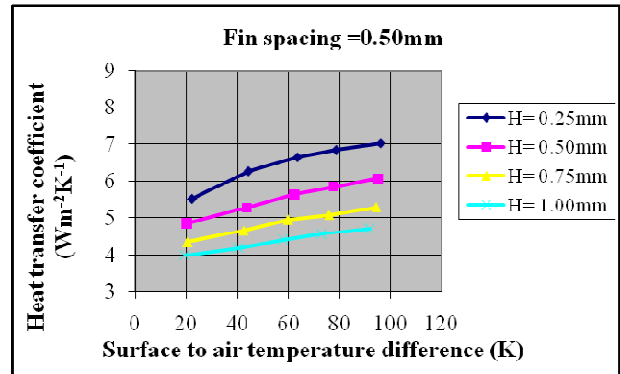

Figure 6: Effect of fin height on the heat transfer coefficient.

$$\text{where } Nu_r = \frac{h_c r}{k}, \quad Ra_r = \frac{g \beta (T_w - T_a) r^3}{\nu \alpha}$$

and $r = 2HS/(2H+S)$ with H being the fin height and S being the fin spacing. Air properties used in the calculations of both Ra_r and Nu_r were obtained at the film temperature defined as the average of T_w and T_a except for the thermal expansion coefficient β which was obtained based on T_a .

They stated that the above correlation predicted their experimental results with an average deviation of 6.3%. They tested a number of micro and mini finned surfaces aligned vertically with fin heights of 100 μ m, 200 μ m and 1mm. The fin spacing used ranged from 30 μ m to 360 μ m for the 100 and 200 μ m fin height and 0.7mm to 7.7mm for the 1mm fin height. They also tested 200 μ m and 1mm microfinned pieces aligned horizontally and concluded that the effect of orientation is negligible. Therefore, their correlation was used to predict the current experimental results shown in Figure 8.

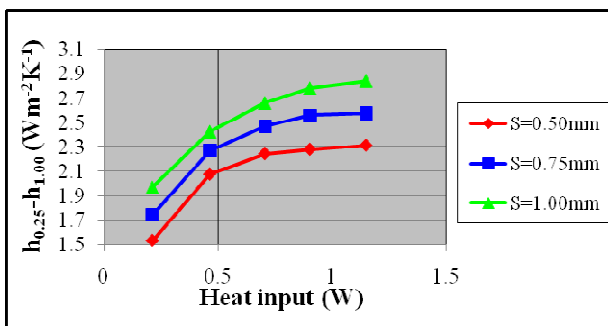

Figure 7: Change of heat transfer coefficient ($h_{0.25}-h_{1.0}$) versus the heat input for different fin spacing.

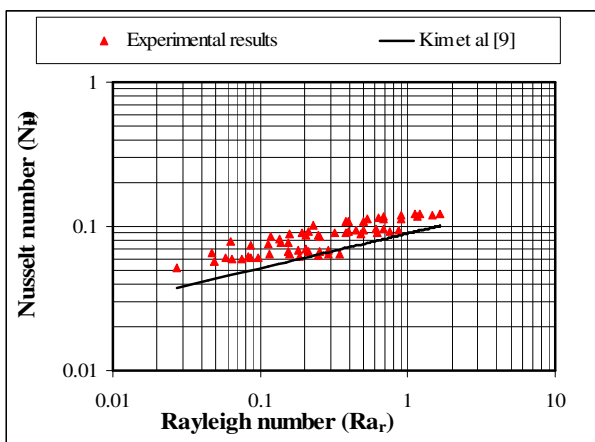

Figure 8: Experimental results compared to Kim et al. [9] correlation.

5. Conclusions

With the emerging potential of micro finned structures in heat removal mechanisms for micro scale applications, the coefficient of heat transfer by natural convection plays an important role. Results from the present work have shown that the values of convective heat transfer coefficient increased with increased fin spacing. In contrast, the convective heat transfer coefficient was shown to decrease as fin height increased. This trend is similar to that reported by Kim et al. [9]. The highest value for convective heat transfer coefficient of $8.158\text{Wm}^{-2}\text{K}^{-1}$ was recorded at the lowest fin height of 0.25mm and spacing of 1.0mm. A maximum reduction in convective heat transfer coefficient of 34.8% due to fin height increase from 0.25mm to 1.0mm was recorded at the maximum temperature difference of 100K with a fin spacing of 1.0mm. It is clear from this research that more work is needed to investigate wider ranges of fin heights, spacing and heating loads, in order to determine the optimum geometries for microfinned heat sinks under the required operating conditions.

6. Acknowledgments

The authors acknowledge the help provided by Ms. Y. Li in carrying out some of the experimental work and data preparation. Additional thanks go to Advantage West Midlands (AWM) for funding the West Midlands Micro Machining Centre at Birmingham, containing the μ -EDWM equipment.

7. References

- [1] X. Jack Hu, Ankur Jain, Kenneth E. Goodson, "Investigation of the natural convection boundary condition in microfabricated structures" International Journal of Thermal Sciences, Volume 47, Issue 7, July 2008, pp. 820-824.

- [2] S. Banerjee, A. Mukhopadhyay, S. Sen, and R. Ganguly, "Natural convection in a bi-heater configuration of passive electronic cooling", *International Journal of Thermal Sciences*, Volume 47, Issue 11, November 2008, pp.1516-1527.
- [3] Z. Guo and Z. Li, "Size effect on microscale single-phase flow and heat transfer", *International Journal of Heat and Mass Transfer*, 46, 2003, pp. 149-159.
- [4] A. Chaehoi, F. Mailly, L. Latorre , P. Nouet, "Experimental and finite-element study of convective accelerometer on CMOS", *Sensors and Actuators A*, 132, 2006, pp. 78-84.
- [5] B. Yazicioglu and H. Yuncu, "Optimum fin spacing of rectangular fins on a vertical base in free convection heat transfer", *Heat Mass Transfer Journal*, 44, 2007, pp.11-21.
- [6] M. Fujii, "Enhancement of natural convection heat transfer from a vertical heated plate using inclined fins", *Heat Transfer Asian Research*, 36 (6), 2007, pp. 334-344.
- [7] Y. M. Ko, C. W. Leung, S. D. Probert, "Steady-state free-convective cooling of heat exchangers with vertical rectangular fins: Effect of fin material", *Applied Energy*, Volume 34, Issue 3, 1989, pp. 181-191.
- [8] L. Dialameh, M. Yaghoubi, O. Abouali, "Natural convection from an array of horizontal rectangular thick fins with short length", *Applied Thermal Engineering*, Volume 28, Issues 17-18, December 2008, pp. 2371-2379.
- [9] J. S. Kim, B. K. Park, and J. S. Lee, "Natural convection heat transfer around microfin arrays", *Experimental Heat Transfer*, 21:1, 2008, pp. 55-72.
- [10] C. Chen and H. Weng, "Natural convection in a vertical microchannel", *Journal of Heat Transfer-ASME*, 127, 2005, pp.1053-1056.
- [11] N. V. Suryanarayana, "Engineering heat transfer", West Publishing Company, 1995, ISBN 0-314-01093-9, Table A9, p. A20.
- [12] D. P. Kulkarni and D. K. Das, "Analytical and numerical studies on microscale heat sinks for electronic applications",
- [13] I. Martorell, J. Herrero and F. X. Grau, "Natural convection from narrow horizontal plates at moderate Rayleigh numbers", *International Journal of Heat and Mass Transfer*, Vol. 46, 2003, pp. 2389-2402.
- [14] W. M. Lewandowski, E. Radziemandska, M. Buzuk and H. Bieszk, "Free convection heat transfer fluid flow above horizontal rectangular plates", *Applied Energy*, Volume, 66, 2000, pp. 177-197.
- [15] T. Fujii and H. Imura, "Natural convection heat transfer from a plate with arbitrary inclination", *International Journal of Heat and Mass Transfer*, Vol. 15, 1972, p. 755.
- [16] J.P. Holman, *Heat Transfer*, Seventh edition, McGraw Hill, ISBN 0-07-112644-9, 1990, Chapter 7, p. 341.