

A REINFORCED CONCRETE MODULAR ROOF UNIT

by

PIET A. KESSELS

B. Arch. Tulane University 1960

and

DONALD M. MATSUBA

B. Arch. University of British Columbia 1959

SUBMITTED IN PARTIAL FULFILLMENT OF THE
REQUIREMENT FOR THE DEGREE OF MASTER IN
ARCHITECTURE AT THE
MASSACHUSETTS INSTITUTE OF TECHNOLOGY

July 1962

Signature of Authors

Piet A. Kessels

Donald M. Matsuba

Signature of the Head of the Department

Lawrence B. Anderson

ABSTRACT

" A REINFORCED CONCRETE MODULAR ROOF UNIT"

by

PIET A. KESSELS

and

DONALD M. MATSUBA

Submitted in partial fulfillment of the requirements for the degree of Master in Architecture in the Department of Architecture on July 27, 1962.

This thesis incorporates the design of a Reinforced Concrete Modular Roof Unit with the functional requirements necessary for an educational building. It is primarily concerned with the development and analysis of a systematized structure, which combines a low peripheral space and a high central space.

It is organized as a joint research project, which presents a common criteria, but proposes individual studies and designs.

OUTLINE OF STUDY:

- 1.) Formulation of design criteria
- 2.) Preliminary studies leading to the proposals.
- 3.) Structural and functional analysis of the proposals.

July 16, 1962

Pietro Belluschi, Dean
School of Architecture and Planning
Massachusetts Institute of Technology
Cambridge 39, Massachusetts

Dear Dean Belluschi,

In partial fulfillment of the requirements for the degree of
Master in Architecture, we hereby submit this thesis entitled,
"A Reinforced Concrete Modular Roof Unit".

Respectfully,

Piet A. Kessels

Donald Michio Matsuba

ACKNOWLEDGMENTS

We are grateful to the following people for their advice and assistance throughout the thesis:

Professor Giulio Pizzetti	Turin, Italy
Doctor Howard Simpson	Cambridge, Mass.
Mr. A.J. Harris	London, England
Professor Robert Newman	Cambridge, Mass.

Professor Eduardo F. Catalano - thesis advisor

TABLE OF CONTENTS

TITLE PAGE	Page	1.
ABSTRACT	Page	2.
LETTER OF SUBMITTAL	Page	3.
ACKNOWLEDGMENT	Page	4.
TABLE OF CONTENTS	Page	5.
LIST OF ILLUSTRATIONS	Page	7.
I. INTRODUCTION	Page	9.
1.) OBJECTIVES		
2.) EXPOSITION		
II. DESIGN CRITERIA	Page	10.
1.) BUILDING TYPE		
2.) SPACES		
3.) STRUCTURAL SYSTEM		
4.) ILLUMINATION		
5.) HEATING AND VENTILATION		
6.) ACOUSTICS		
7.) ELECTRICAL SERVICES		
8.) PLUMBING		
9.) THERMAL INSULATION		
III. DESIGN PROPOSAL by PIET A. KESSELS	Page	15.
1.) STUDY NO.1		
2.) STUDY NO. 2 (PROPOSAL)		
IV. DESIGN PROPOSAL by DONALD M. MATSUBA	Page	47.
1.) STUDY NO. 1		
2.) STUDY NO. 2		
3.) STUDY NO. 3 (PROPOSAL)		

TABLE OF CONTENTS

APPENDIX - RESEARCH MATERIAL	Page	82.
BIBLIOGRAPHY -	Page	95.

LIST OF ILLUSTRATIONS

III. DESIGN PROPOSAL

Figure III-1	Study No. 1
Figure III-2	Study No. 1
Figure III-3	Analysis of Major Space
Figure III-4	" " " "
Figure III-5	" " " "
Figure III-6	Study No. 2 (Proposal)
Figure III-7	Acoustics---Approximate Absorbent Required

IV. DESIGN PROPOSAL

Figure IV-1	Study No.1
Figure IV-2	Study No. 2
Figure IV-3	Study No. 3 (Proposal)
Figure IV-4	Acoustics---Approximate Absorbent Required

APPENDIX .. RESEARCH

Figure A-1	Double T
Figure A-2	Channel Slabs
Figure A-3	Girder-Purlin-Plank System
Figure A-4	Composite System
Figure A-5	One-way Slab
Figure A-6	Two-way Slab
Figure A-7	Inter-grid System
Figure A-8	A Prototype Structure
Figure A-9	An Elementary School
Figure A-10	West Bridgewater, Mass. School

I. INTRODUCTION

1.) OBJECTIVES

- a) To develop a reinforced concrete modular roof unit defined by a low peripheral space and a high central space.
- b) To analyze the structural behavior of the roof unit.
- c) To incorporate into the modular unit the functional requirements of a prototype school.
- d) To direct the thesis toward a design approach with broad applications.

2.) EXPOSITION

The Masters' Thesis program offers the opportunity to approach the problem of a modular roof unit for schools, without the limitations of specific site conditions. With this freedom, the total effort of the thesis can be concentrated on the interrelation between the structural behavior and the functional requirements of the roof unit.

Therefore, this thesis is a study of a particular use of reinforced concrete which presents some of the possibilities and limitations of the material.

II. DESIGN CRITERIA

1.) BUILDING TYPE

To accommodate 30 to 35 students, a floor area of approximately 900 square feet is required. This dimension is determined by the physical proximity of students during various classroom activities. The subsidiary activities, which are related to the classroom, require a linear dimension of 10 to 12 feet.

2.) SPACES

The intimate and individual activities are accommodated by a low peripheral space. These areas are: unit libraries, offices, conference rooms, work areas, lavatories, toilet rooms, storage, and corridors. The collective activities are defined by the high space.

2.1) Quality of the High Space

The high space provides a psychological and physiological environment, which encourages group participation among young people. The volume is determined by the various requirements necessary for proper classroom functions, such as: illumination, heating, ventilating, and acoustics.

2.2) Quality of the Low Space

The lower more intimate space offers a modular flexibility and the advantage of placement of partitions in both directions.

3.) STRUCTURAL SYSTEM

The roof unit is a single structural system which expresses the high and the low spaces that it encloses. The

transition between the two surfaces imposes the specific structural problem of stress distribution.

3.1) The High Roof

The structure of the high space derives its form from the expression of the spacial requirements and the structural implications of the transition from the low to the high roof.

The geometric breakdown of the high roof varies with each proposal.

3.2) The Low Roof

The most feasible roof structure, which can span 30 feet economically and which offers modular flexibility is the two-way ribbed slab. A dimension of 3 feet is a reasonable module because:

- a.) A door can be detailed within this dimension.
- b.) Standard toilet partitions are adaptable to 3 feet.
- c.) 6 feet is a minimum and 9 feet is adequate for a single loaded corridor. 12 feet is sufficient for a double loaded corridor.
- d.) 3 feet and 6 feet are adequate dimensions for protection of the exterior glazed surfaces.
- e.) 3 feet by 3 feet metal pans are a standard size.
- f.) Fluorescent and incandescent lighting fixtures can be integrated within the voids created by the metal pans.

3.3) System of Supports

The columns are located at the corners of the major space. The exact location of these columns is determined by the structural behavior and the geometry of the systematized roof.

4. ILLUMINATION

The criteria for providing a luminous environment for people who are doing close visual work are:

- a.) Sufficient light - 35 to 70 foot candles
- b.) A "helio" (brightness ratio) of approximately 3 to 1 (the surface of illumination is not to be brighter than three times that of its immediate surroundings)¹

4.1) Natural Light

The introduction of natural light into the classroom provides psychological stimulation which is essential for student activities. The major space, as well as some of the peripheral smaller spaces require natural light. This light, which is introduced through skylights, must be free of glare.

4.2) Artificial Light

Artificial light is required to provide adequate illumination for various activities. The fixture dimensions are integrated into the surface geometry of the structure.

5. Heating and Ventilation

The particular heating and ventilating system to be used in each proposal will vary with the climatic regions. However there are a few criteria which remain as common denominators to the project.

a.) Because the building is only one story, the heating and ventilation system is to be free of the structure.

b.) In order for a classroom to be comfortably ventilated, fresh air is introduced at the bottom and undesirable

1. Moon, Parry, The New Approach to Room Lighting, Reprint from Illumination Engineering. April, 1949. p.223.

air is removed through an exhaust vent at top. The rate of air change is related to the volume.

c.) For flexibility, an even distribution of heating and ventilation is provided throughout the enclosed space.

6. ACOUSTICS

There are three basic acoustical requirements for good hearing conditions in a classroom.

6.1) Distribution of Sound

Often in a classroom, direct sound from a source is inadequate for a proper distribution. Reflected sound off the ceiling must be utilized to reinforce the direct sound.

6.2) Noise Criteria

A noise criteria (N.C.) of 35 decibels is an acceptable background noise level within a classroom. The transmitting characteristics of building materials, the quality of joint details and the manner of introducing ventilation, determine the noise criteria of a room.

6.3) Reverberation Time

The reverberant quality of a room depends directly upon the volume and inversely on the absorptive nature of the building material. Reverberation time of a classroom is to be calculated for two conditions:

- a.) when the classroom is fully occupied.
- b.) when the classroom is not occupied.

A reverberation time of approximately one second is acceptable.

7. ELECTRICAL SERVICES

In order to obtain even distribution of electrical

services, they are integrated into the structure. The low voltage system which is employed, has the advantages of reducing dimensions of wires, conduits, junction boxes, and switches.

8. PLUMBING

Supply and waste lines are provided in the floor. The roof slab allows passage of the vent stacks and ventilators. Rain water drains are integrated in the columns.

9. THERMAL INSULATION

Thermal insulation is placed on the outer surfaces of the structure, together with the waterproofing membrane. This detail permits the interior surface of the structure to be exposed.

III. DESIGN PROPOSAL

A Reinforced Concrete Modular Roof Unit, Its Application
to Schools in New Orleans.

by

PIET A. KESSELS

1. STUDY NO.1

1-1 Description

Study No. 1 consists of a low, flat two-way system which surrounds four deep (7'-0") beams that support an upper flat two-way system.

The structure has one system of supports, consisting of four columns. The columns are located near the point of transition between the low and high roof and directly below the four major beams. The lower two-way system cantilevers from the major beams. These beams are triangulated (similar to a truss) and admit natural light. The fins which project from the beams serve as protection for the clerestory lighting and also help resist the negative moment of the cantilever.

The entire system is formed by non-removable, precast concrete forms, designed for proper insulating and acoustic values. Artificial light is introduced in the form of troughs placed in the voids of the two-way system.

Partitions are placed on the 3'-0" orthogonal grid of the lower two-way system.

1-2 Criticism

a.) Introduction of natural light from four sides might produce excessive glare and problems of sun protection. One source of natural light would be more advisable.

b.) The transition from the low space to the high space is confusing.

c.) The 3'-0" wide band of the low two-way system which protrudes into the major space is not sufficient to produce the effect of a lower portion surrounding the major space.

d.) Placement of concrete and roofing material on a surface of many different planes would be extremely difficult.

e.) Although the structure is overdesigned for such a modest span there is a certain amount of inefficiency, produced by concentrating the bending moment of the cantilever at the junction points of the major beams.

f.) Finally, a general simplification of the entire system is necessary.

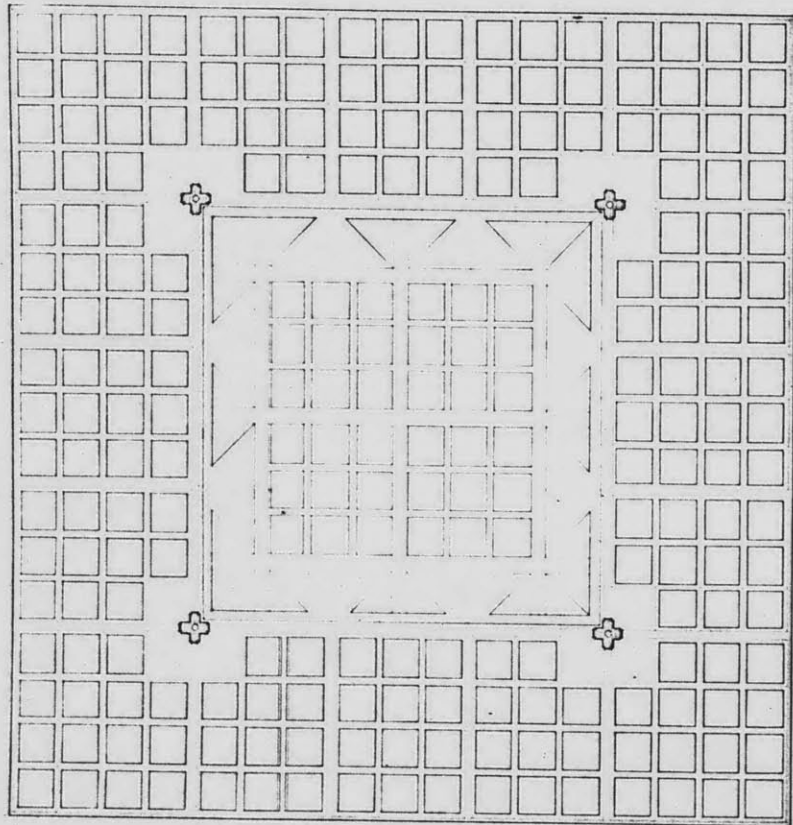

REFLECTED CEILING PLAN 1/8"=1'-0"
SCALE
FEET

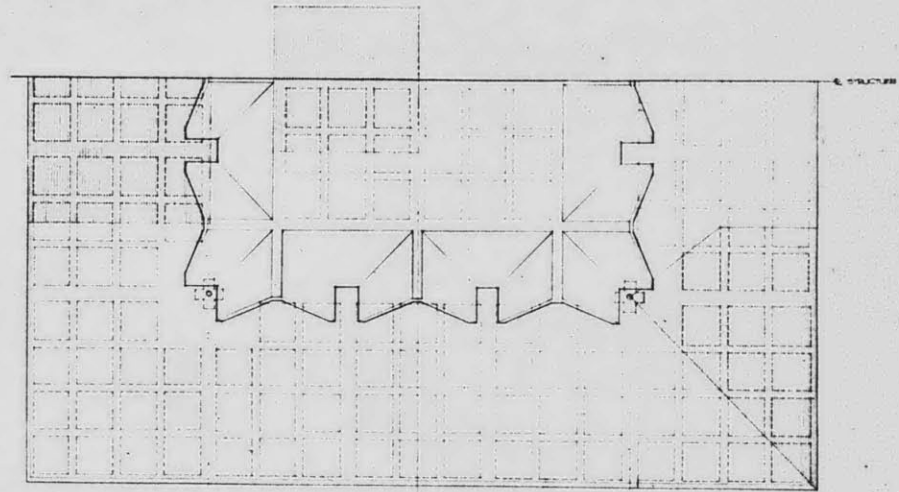

LONGitudinal SECTION

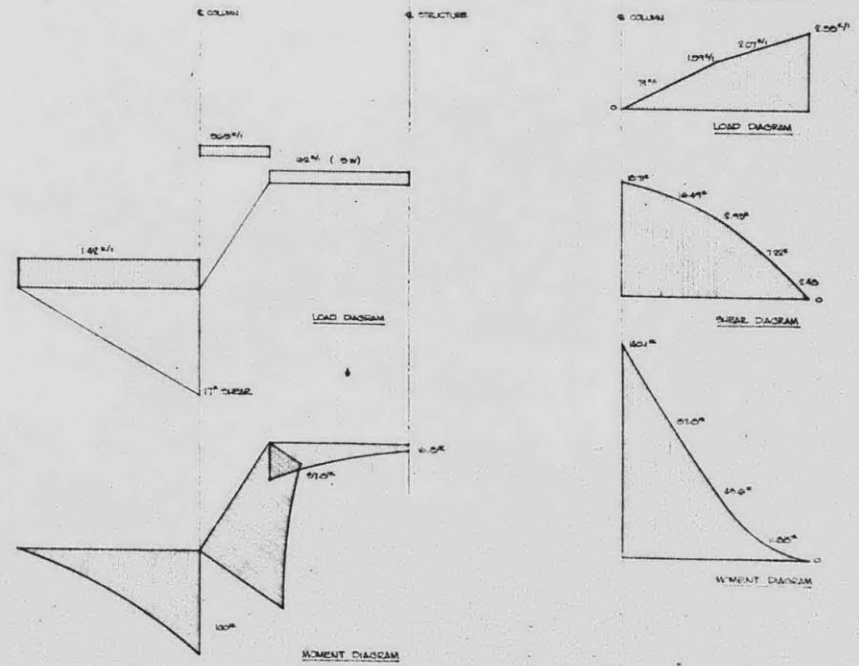
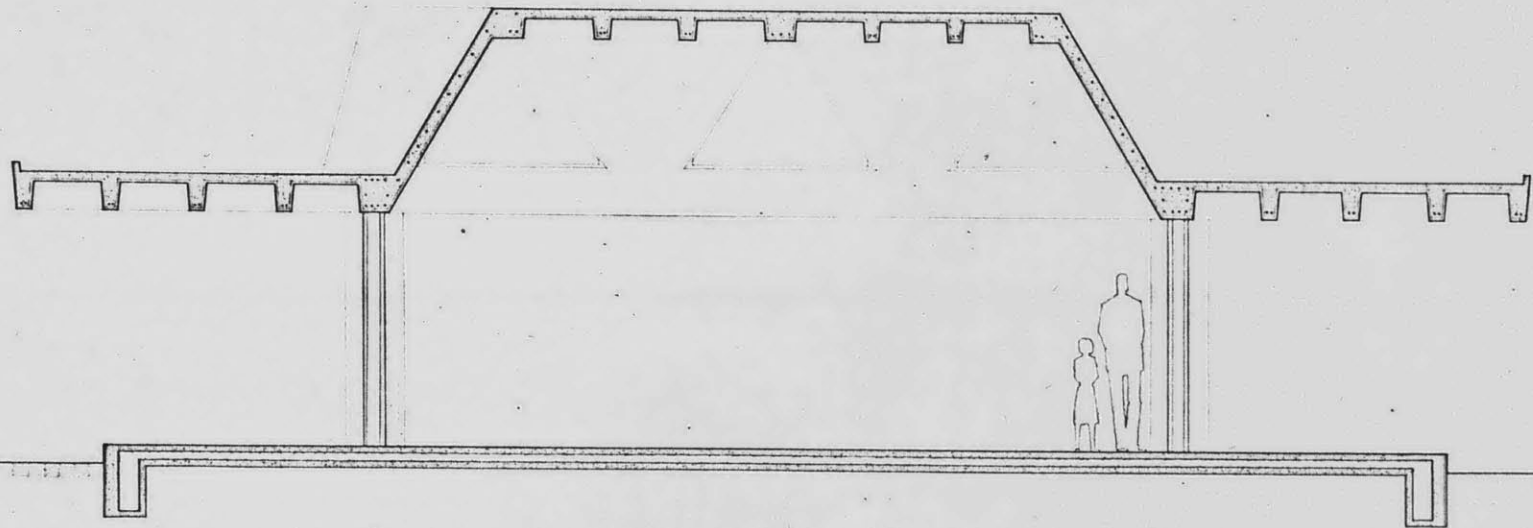

FIGURE III-1



TYPICAL SECTION 1/4" = 1'-0"

FIGURE III-2

2. STUDY NO. 2 (PROPOSAL)

2-1 Description

Study No. 2 consists of a low, flat two-way system which surrounds four parabolic curved surfaces that form the major collective space.

The lower portion of the structure is formed with standard metal pans. The parabolic curve is generated by a series of horizontal lines and is formed with 3" tongue and groove decking. These generatrices were chosen because of the effects caused by the play of natural light on them.

A divider strip has been placed between the metal pans to produce a 1" x 3/4" reglet. This reglet receives a standard head element for the partitions. Allowances in partition design for variations in the concrete, due to forming or deflection is thereby eliminated.

The design of the modular roof unit is based on three major considerations:

The desired special quality

The structural behavior

The functional requirements

2.2 ANALYSIS OF THE MAJOR SPACE

Study No. 1 was criticized for a confusing transition between the low and high space. A 3'-0" band of the low area around the major space is insufficient for a proper transition. (figure III-3a). By increasing this low area structural inefficiency and improper balance of the structure results. (figure III-3b).

A gradual transition between the low space and the high space generated by a curved surface, can produce the total effect of a unified major space and yet respect the lower surrounding portion by allowing a sufficient amount of the area to protrude into the space. (figure III-3c).

Once it is assumed that a curved surface can produce the desired transition, the exact shape of the curve must be determined. An arbitrary curve is difficult to construct under job conditions, consequently, a geometric curve should be found which best satisfies the design criteria.

There are a number of possible geometric curves.

1. The Hyperbola (with its centerline perpendicular to the ground line) (figure III-4a).
2. The Parabola (with its centerline perpendicular to the ground line) (figure III-4b).
3. An Arc of a Circle (figure III-5a).

The four centered oval and the ellipse are also possible curves, but because the dimensions of height and width of the curve is similar, the difference between these two curves and the arc of a circle is negligible.

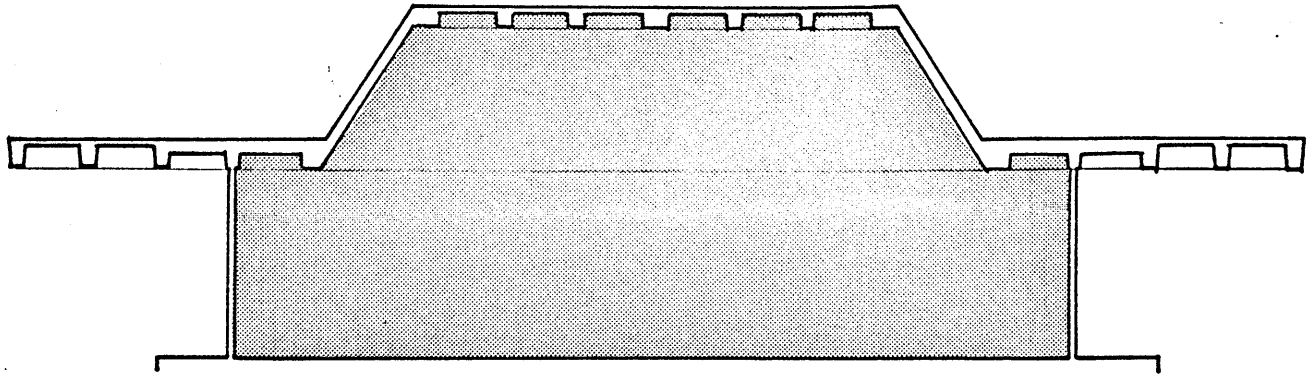

SECTION A

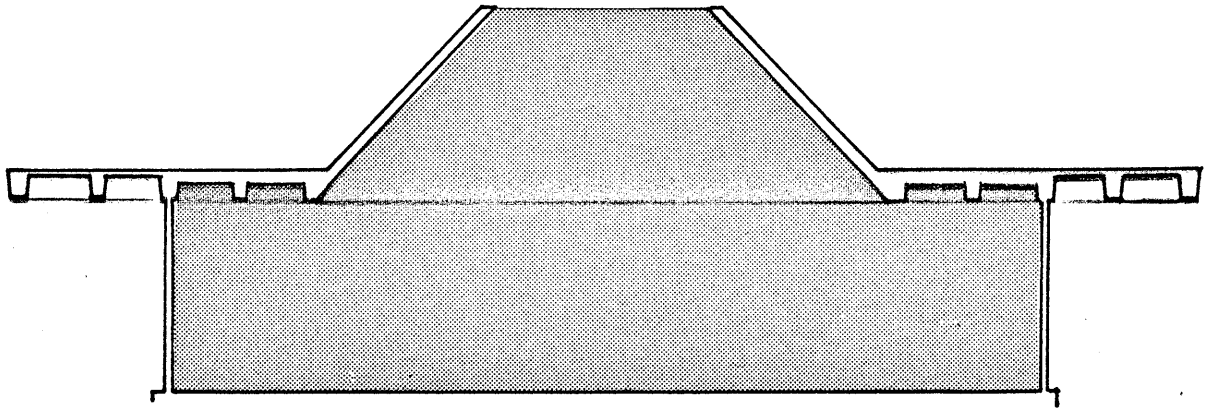

SECTION B

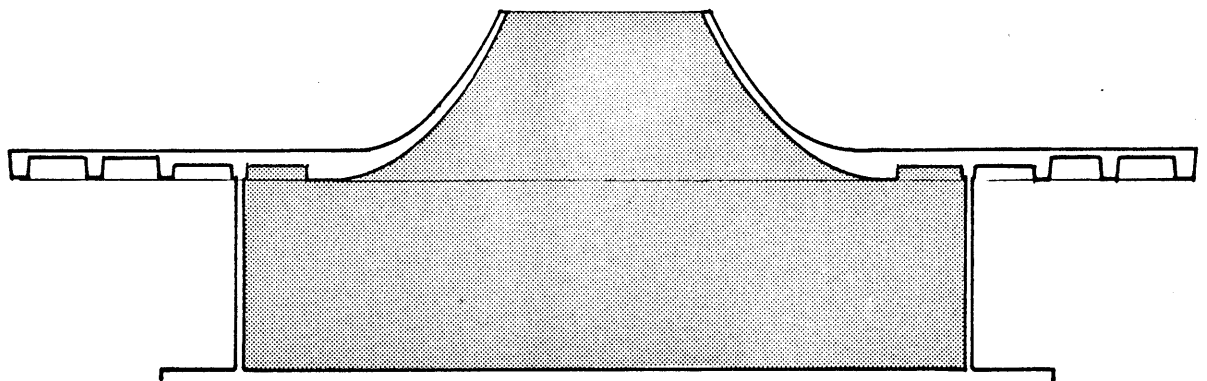

SECTION C

FIGURE III-3

4. The full parabola (with its centerline at an angle of 45° with the ground line) (figure III-5b).

The parabola (with its centerline perpendicular to the ground line) was chosen for these reasons:

- a.) This curve achieves the desired proportion of low surface before rising up to the high space.
- b.) As the curve gets deeper its structural efficiency decreases. The parabola is a relatively flat curve.
- c.) The deep curves rob the major area of the necessary volume for a space of these dimensions.
- d.) The deep curves require much more unnecessary concrete (and consequently, more dead load) in the transition from the low space to the high space.

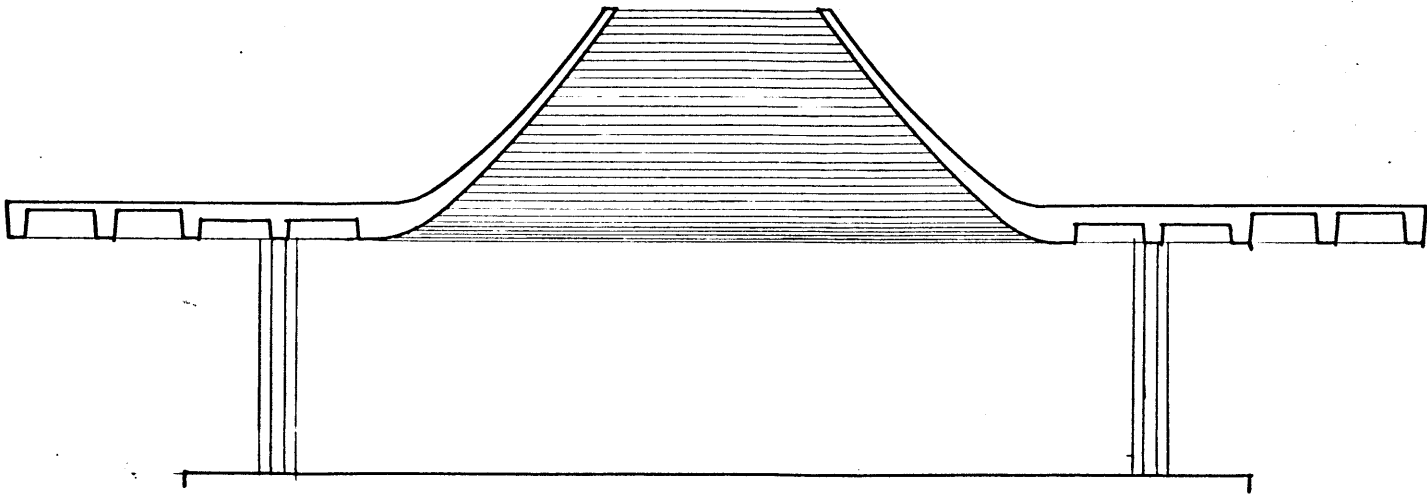

A. HYPERBOLA

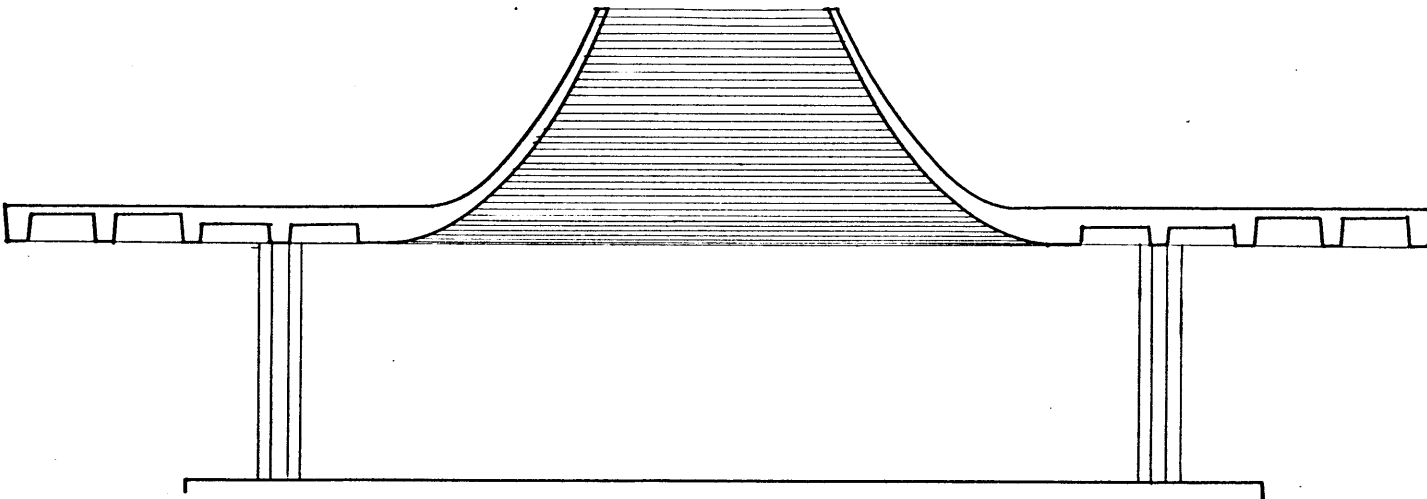

B. PARABOLA

FIGURE III-4

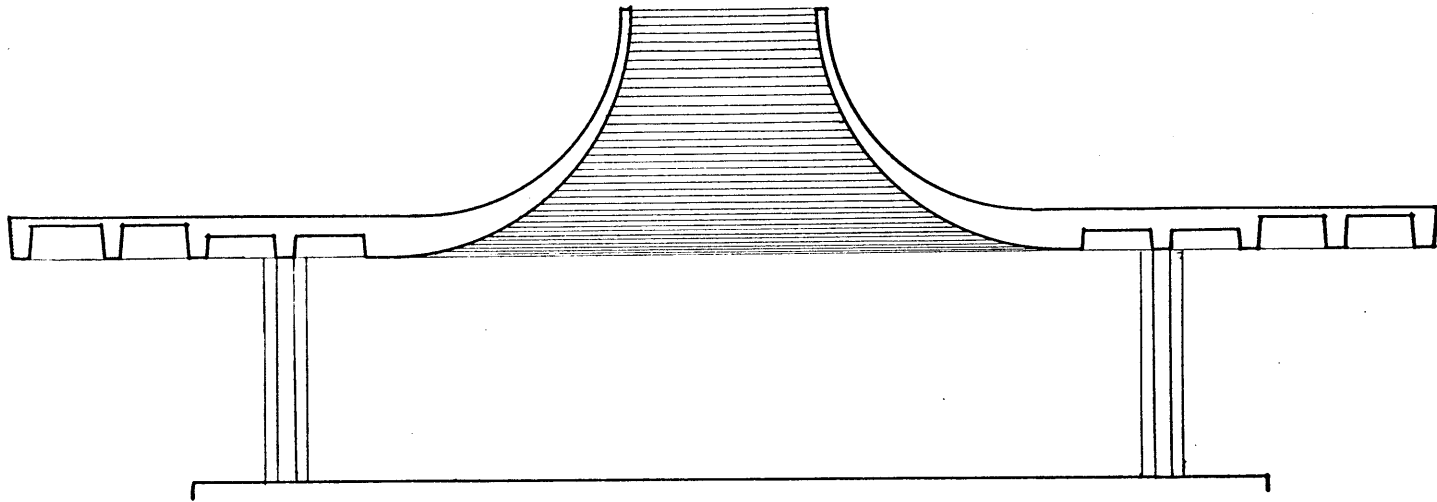

A. ARC OF A CIRCLE

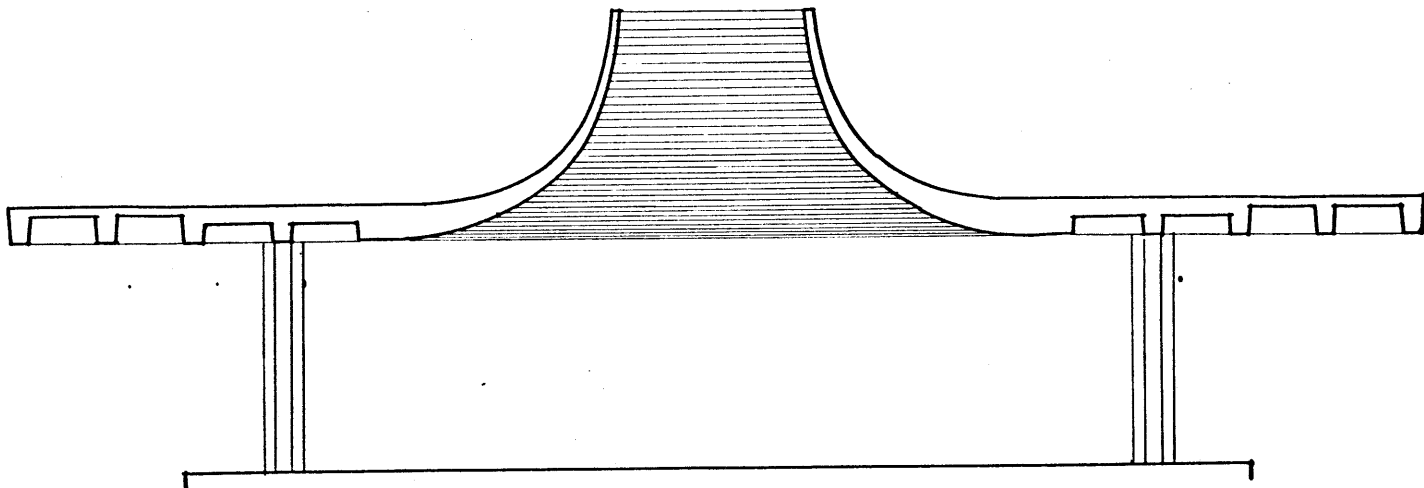

B. FULL PARABOLA

FIGURE III-5

2-3 STRUCTURAL ANALYSIS

The structure is a composite one, which is rather difficult to classify according to common structural forms. It has two characteristic parts, a lower two-way ribbed slab and a central parabolic curved structure.

The two-way ribbed slab is 15" deep; spans 30' -10" and cantilevers 9'-3" from the centerline of the column. The ribs are 7" wide and spaced 3'-1" apart. The three inner ribs are 8" deep and topped with a 7" slab; the three outer ribs are 12" deep with a 3" topping slab. The four panels directly above the columns are dropped to provide a shear head. The cruciform shaped columns are 18" in their longest dimension and 7" in width.

The central parabolic curved structure reduces in depth from 15" to 3" and has an average slope of 55° .

A. Assumptions

It would be difficult to study either the two-way ribbed slab or the central curved structure alone in exact mathematical terms. Furthermore, these two portions of the structure are connected together in such a way that they influence each other. For this reason the structural analysis is an approximation of the behavior of the stresses, based on these assumptions.

1.) Sectional analysis can be performed prior to distributional analysis.

2.) Symmetrical loading exists throughout the structure.

(In the design of the columns the possibility of eccentric loading is considered).

3.) The two-way ribbed slab will behave as plates. It is divided into two strips of reinforcement; a "column" strip and an "edge" strip.

4.) The carrying capacity of each strip will vary inversely with its relative deflection.

5.) The stresses in each strip are divided equally, by area, into the individual ribs.

6.) For initial deflection only the live load is considered (initial dead load deflection is eliminated by cambering the forms). This short time deflection is calculated by the elastic frame method. The total long term deflection is the sum of the live load and $2\frac{1}{2}$ times the dead load deflection.

7.) The central structure will transfer a majority of its load through the shear head to the columns.

8.) The upper portion of the central structure which is relatively straight and constant in slope behaves like an inclined two-way slab restrained on three sides. (figure III-6 points C-D).

9.) The lower portion of the central structure works like a bending resistant curved surface and is considered as a part of the column strip. (figure III-6 points B-C).

10.)	Unit load acting on the upper structure is	125 psf
	Unit load acting on the column strip is	190 psf
	Unit load acting on the edge strip is	150 psf
	Live load is	50 psf

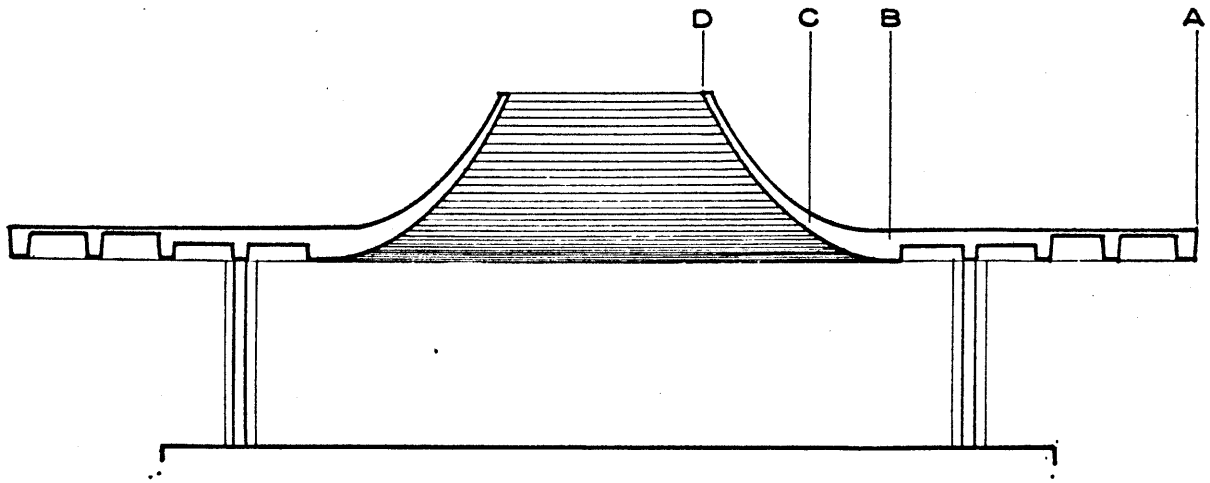

SECTION

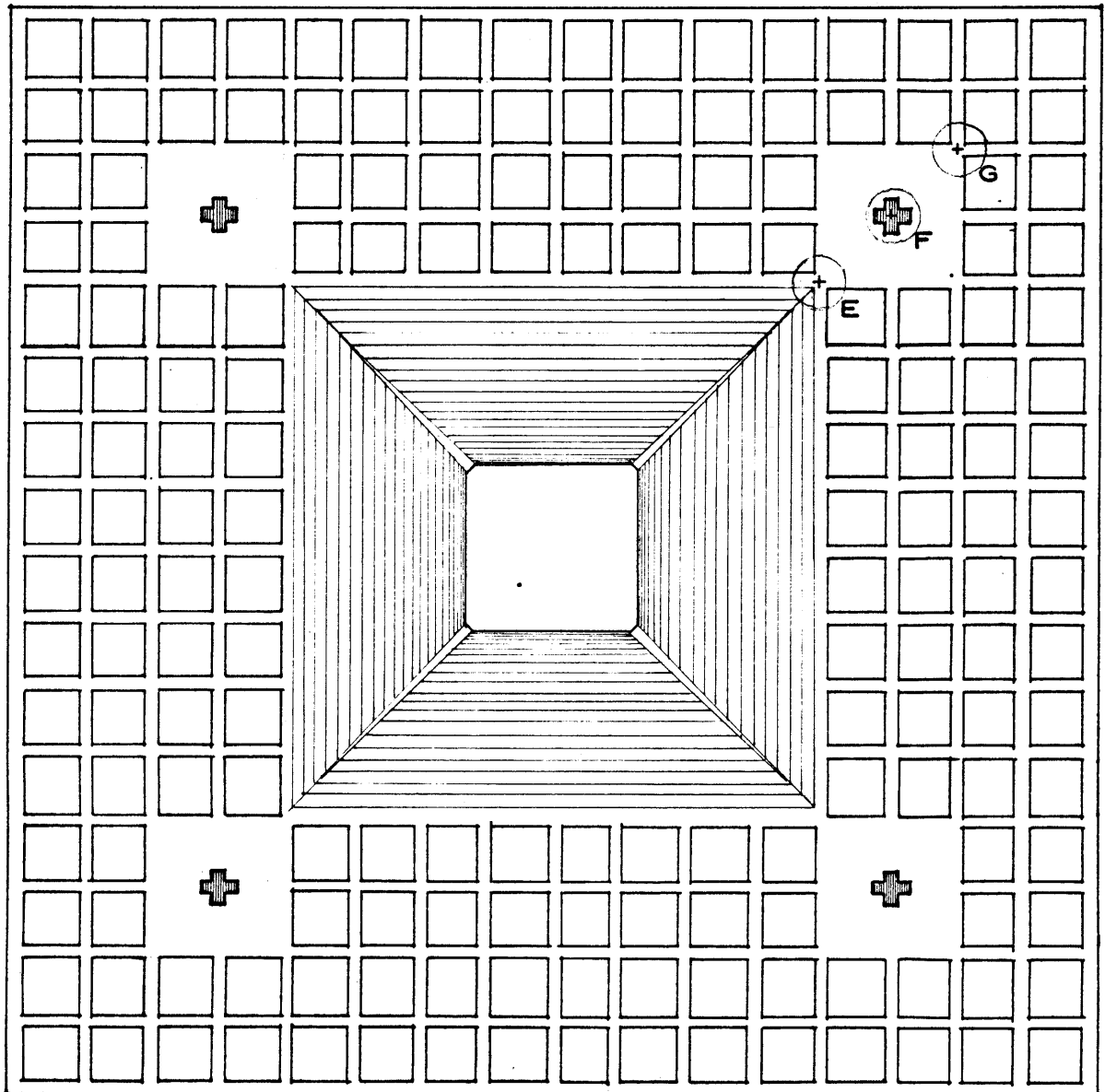

PLAN

FIGURE III-6

- 11.) Load carrying capacity of the soil is 4,000 psf.
- 12.) Ultimate compressive strength of concrete 3,000 psi.
Allowable stress intensile reinforcement
and in column reinforcing 20,000 psi.

B. Analysis

1.) The Lower Slab

The preliminary analysis of relative deflection determined the loading pattern of the two-way ribbed slab. The column strip transfers two thirds of the total load to the columns. The remaining one third of the load is transferred from the edge strip, to the column strip cantilever and into the column.

The slab is analyzed in two directions:

- a.) Both strips were analyzed for stresses in the longitudinal direction (column to column).
- b.) The distribution of stresses from the ribbed slab to the central structure is analyzed in the transverse direction. The negative moment of the ribbed slab is dissipated to a value equal to the negative moment of the upper two-way slab, at the point where the thickness and slope of the upper portion becomes relatively constant. Because it is possible that the portion between the column line and the point of even thickness could produce a positive moment the bending moment diagram is broken to indicate both the negative and positive moments

possible. The possibility of the existence of these two moments is considered as a safety factor.

2.) The Central Structure

The central structure is analyzed as an inclined two-way slab. Seventy-five percent of the load acting on it is transferred to the corner of the shear head and then into the column. The local stresses produced by this eccentricity are small and of minor importance.

3.) The Columns

Three positions were analyzed in the determination of the column location.

- a.) If the columns are placed at the point where the central structure joins the lower structure, bending stresses in the cantilever become excessive (figure III-6 point E).
- b.) If the columns are placed closer to the perimeter the bending and shear stresses in the drop panel produced by the load of the central structure, become excessive. (figure III-6 point F).
- c.) At a point 9'-3" from the edge of the structure the bending of the cantilever is within an acceptable value and the local stresses produced in the drop panel are easily restrained by reinforcing steel.

The columns are designed with the possibility of unsymmetric loading. They are fixed at the top and pinned at the bottom to prevent bending stresses from being transferred into the footing.

RELATIVE DEFLECTION OF LOWER ROOF STRUCTURE

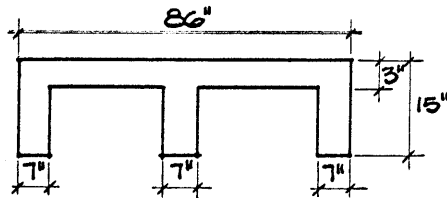
CANTILEVER COLUMN STRIP

EQUIV. SECTION

$$\begin{aligned} b &= 86'' \\ b' &= 3(7) = 21'' \\ t &= 3'' \\ h &= 15'' \end{aligned}$$

$$\begin{aligned} b/b' &= 4.1 \\ t/h &= .2 \end{aligned}$$

$$C = 1.7$$

MOMENT OF INERTIA

$$\begin{aligned} I &= \frac{C \times b \times h^3}{12} \\ &= \frac{1.7 \times 21 \times 15^3}{12} \\ I &= 10,000 \text{ IN.}^4 \end{aligned}$$

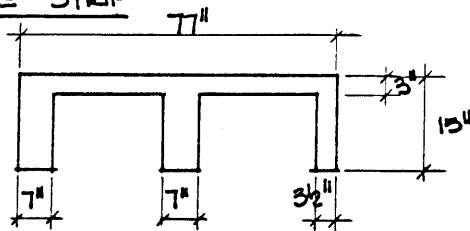
EDGE STRIP

EQUIV. SECTION

$$\begin{aligned} b &= 77'' \\ b' &= 17.5'' \\ t &= 3'' \\ h &= 15'' \end{aligned}$$

$$\begin{aligned} b/b' &= 4.4 \\ t/h &= .2 \end{aligned}$$

$$C = 1.8$$

MOMENT OF INERTIA

$$\begin{aligned} I &= \frac{1.8 \times 17.5 \times 15^3}{12} \\ I &= 8,900 \text{ IN.}^4 \end{aligned}$$

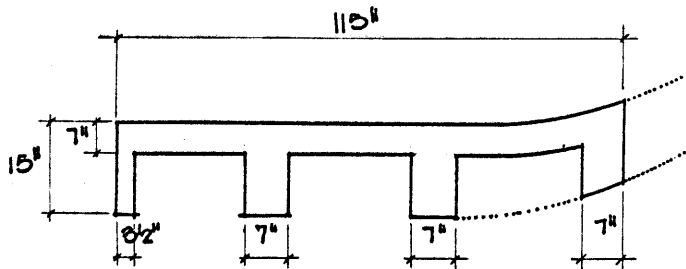
COLUMN STRIP

EQUIV. SECTION

$$\begin{aligned} b &= 115'' \\ b' &= 24.5'' \\ t &= 7'' \\ h &= 15'' \end{aligned}$$

$$\begin{aligned} b/b' &= 4.7 \\ t/h &= .46 \\ c &= 2.0 \end{aligned}$$

MOMENT OF INERTIA

$$\begin{aligned} I &= 2 \times 24.5 \times 15^3 \\ &\quad 12 \\ &= 13,800 \text{ IN.}^4 \end{aligned}$$

ASSUME 10,000 LBS. ACTING

CANTILEVER DEFLECTION

EFFECTIVE W = 5,000 LBS.

$$\Delta = \frac{WL^3}{3EI} \quad L = 9.2 \text{ FT.}$$

$$\Delta = \frac{5 \times 10^3 \times 9.2^3 \times 1.728 \times 10^3}{3 \times 3 \times 10^6 \times 10^4}$$

$$= .075''$$

EDGE STRIP DEFLECTION

W = 10,000 LBS.

L = 30.8 FT.

$$\Delta = \frac{WL^3}{76.8EI}$$

$$\Delta = \frac{10^4 \times 30.8^3 \times 1.728 \times 10^3}{76.8 \times 3 \times 10^6 \times 8.9 \times 10^3}$$

$$\Delta = .249''$$

COLUMN STRIP DEFLECTION

$$\Delta = \frac{10^4 \times 30.8^3 \times 1.728 \times 10^3}{76.8 \times 3 \times 10^6 \times 13.8 \times 10^3}$$

$$\Delta = .16''$$

RELATIVE DEFLECTION

A. CANTILEVER + EDGE STRIP = .075 + .249 = .324''

B. COLUMN STRIP = .16 = .16''

∴ LOAD TAKEN BY COLUMN STRIP = 66.6%

LOAD TAKEN BY EDGE STRIP = 33.3%

LOADING PATTERN FOR LOWER ROOF

LL. + D.L IN KIPS
 D.L IN () KIPS

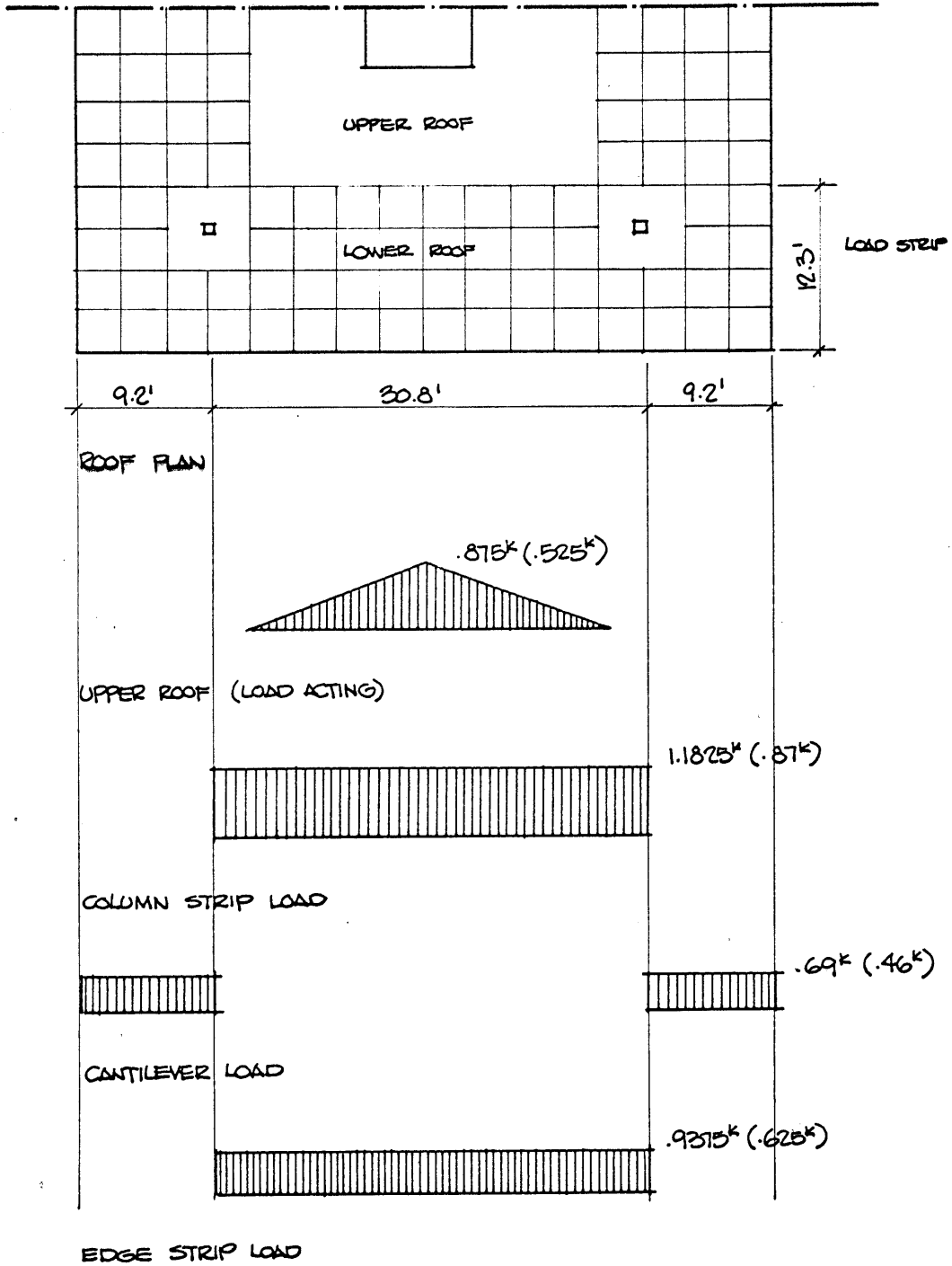

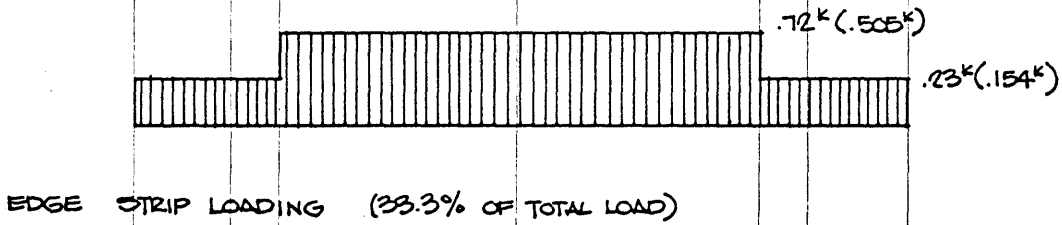
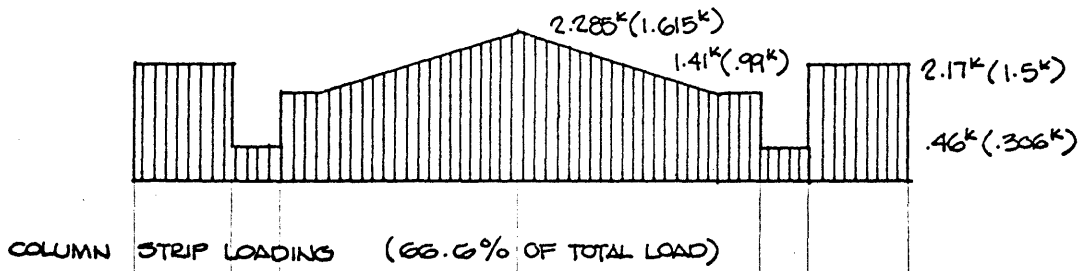

BENDING MOMENT, SHEAR AND DEFLECTION OF COLUMN STRIP .

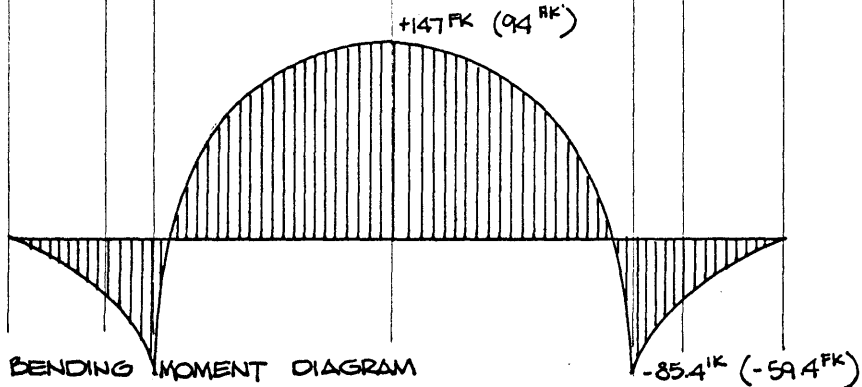
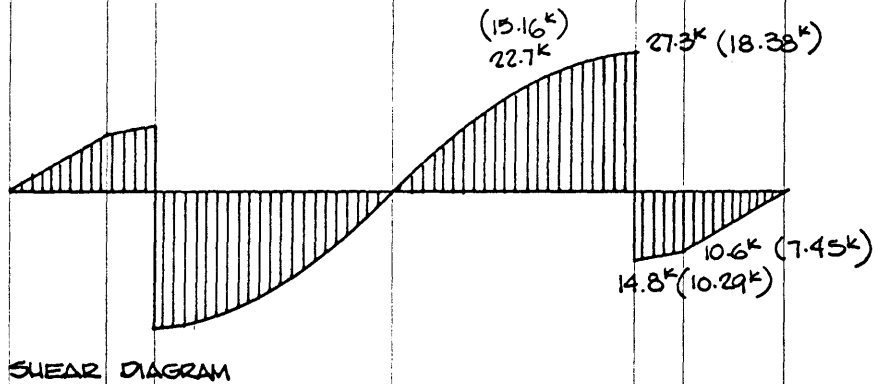

L.L + D.L. DEFLECTION OF SPAN

$$+ \Delta = \frac{WL^3}{76.8EI}$$

$$+ \Delta = \frac{54.6 \times 10^3 \times 30.8^3 \times 1.728 \times 10^3}{76.8 \times 3 \times 10^6 \times 13.8 \times 10^3}$$

$$+ \Delta = .865''$$

$$- \Delta = \frac{3ML^2}{48EI}$$

$$- \Delta = \frac{3 \times 1.024 \times 10^6 \times 30.8 \times 1.44 \times 10^2}{48 \times 3 \times 10^6 \times 13.8 \times 10^3}$$

$$- \Delta = .2 \times 2 = .4$$

$$\text{DEFLECTION} = .865 - .4 = .465''$$

D.L. DEFLECTION

$$+ \Delta = \frac{36.8 \times 10^3 \times 30.8^3 \times 1.728 \times 10^3}{76.8 \times 3 \times 10^6 \times 13.8 \times 10^3}$$

$$\Delta = .582''$$

$$M = -59.4^{\text{FK}}$$

$$- \Delta = \frac{3 \times 7.13 \times 10^3 \times 30.8^2 \times 144}{48 \times 3 \times 10^6 \times 13.8 \times 10^3}$$

$$- \Delta = .1465 \times 2 = .293$$

$$\text{DEFLECTION} = .582 - .293 = .289''$$

$$\text{L.L. + D.L. DEFLECTION} = .465''$$

$$\text{D.L.} = .289''$$

$$\text{L.L.} = .176''$$

$$\text{SHORT TERM DEFLECTION} = .176''$$

$$\text{LONG TERM DEFLECTION} = .723''$$

$$\underline{\text{TOTAL LONG TERM DEFLECTION}} = .899''$$

DEFLECTION OF COLUMN STRIP CANTILEVER

L.L. + D.L. DEFLECTION OF CANTILEVER

$$\begin{aligned} \text{UNIFORM LOAD } \Delta &= \frac{WL^3}{8EI} \\ &= \frac{4.23 \times 10^3 \times 9.2^3 \times 1.728 \times 10^3}{8 \times 3 \times 10^6 \times 10^4} \\ &= .0258'' \end{aligned}$$

CONCENTRATED LOAD (ASSUMED)

$$\begin{aligned} \Delta &= \frac{Wb^2}{6EI} (3L-b) \\ &= \frac{10.6 \times 10^3 \times 6.2^2 \times 144 \times 2.56 \times 10^2}{6 \times 3 \times 10^6 \times 10^4} \\ &= .0838'' \end{aligned}$$

$$\text{DEFLECTION} = .0258 + .0838 = .1096''$$

D.L. DEFLECTION

$$W = 7.44k$$

$$\begin{aligned} \text{UNIFORM LOAD } \Delta &= \frac{2.82 \times 10^3 \times 9.2^3 \times 1.728 \times 10^3}{8 \times 3 \times 10^6 \times 10^4} \\ &= .0173'' \end{aligned}$$

CONCENTRATED LOAD (ASSUMED)

$$\begin{aligned} \Delta &= \frac{7.44 \times 10^3 \times 6.2^2 \times 144 \times 2.56 \times 10^2}{6 \times 3 \times 10^6 \times 10^4} \\ &= .0588'' \end{aligned}$$

$$\text{DEFLECTION} = .0173 + .0588 = .0761''$$

$$\begin{aligned} \text{L.L. + D.L. DEFLECTION} &= .1096'' \\ \text{D.L.} &= .0761'' \\ \text{L.L.} &= .0335'' \end{aligned}$$

$$\begin{aligned} \text{SHORT TERM DEFLECTION} &= .0335'' \\ \text{LONG TERM DEFLECTION} &= .1910'' \\ \text{TOTAL LONG TERM DEFLECTION} &= .2245'' \end{aligned}$$

BENDING MOMENT, SHEAR AND DEFLECTION OF EDGE STRIP

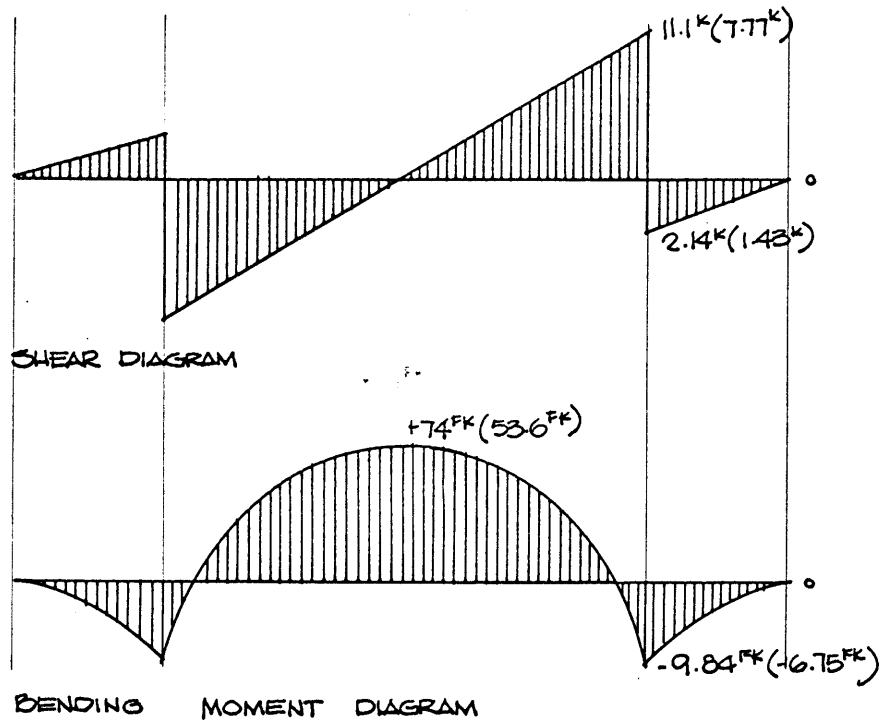
L.L. + D.L. DEFLECTION OF SPAN

$$+ \Delta = \frac{22 \times 10^3 \times 30.8^3 \times 1.728 \times 10^3}{76.8 \times 3 \times 10^6 \times 8.9 \times 10^3}$$

$$+ \Delta = .54''$$

$$- \Delta = \frac{3 \times 1.18 \times 10^5 \times 30.8^2 \times 144}{48 \times 3 \times 10^6 \times 8.9 \times 10^3}$$

$$- \Delta = .038'' \times 2 = .076''$$

$$\underline{\text{DEFLECTION}} = .54 - .076 = .464''$$

UPPER ROOF ANALYSIS

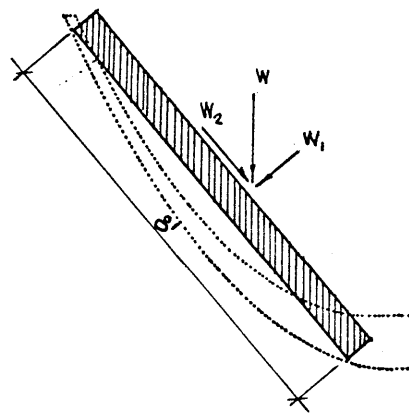
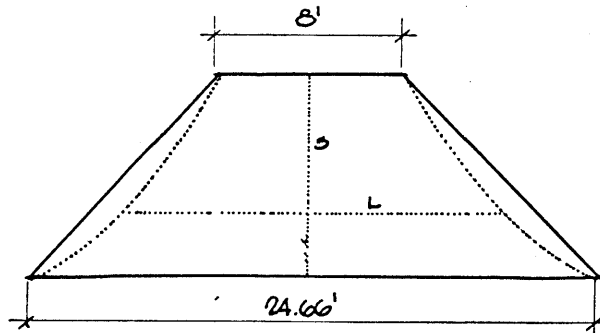

$$W = 125 \text{ p.s.f.}$$

$$W_1 = 71.7 \text{ p.s.f.}$$

$$W_2 = 102.5 \text{ p.s.f.}$$

$$S = 8'$$

$$L = 16.16'$$

SHORT SPAN BENDING MOMENTS

$$\text{AT RESTRAINED EDGE} = \frac{.085 (71.7) (8^2)}{1000} = .39 \text{ FK}$$

$$\text{AT DISCONTINUOUS EDGE} = \frac{.042 (71.7) (8^2)}{1000} = .193 \text{ FK}$$

$$\text{AT MID-SPAN} = \frac{.064 (71.7) (8^2)}{1000} = .294 \text{ FK}$$

LONG SPAN BENDING MOMENTS

$$\text{AT RESTRAINED EDGE} = \frac{.041 (71.7) (16.16^2)}{1000} = .767 \text{ FK}$$

$$\text{AT MID-SPAN} = \frac{.021 (71.7) (16.16^2)}{1000} = .58 \text{ FK}$$

7.57

1.767

ANALYSIS OF MID-STRIP

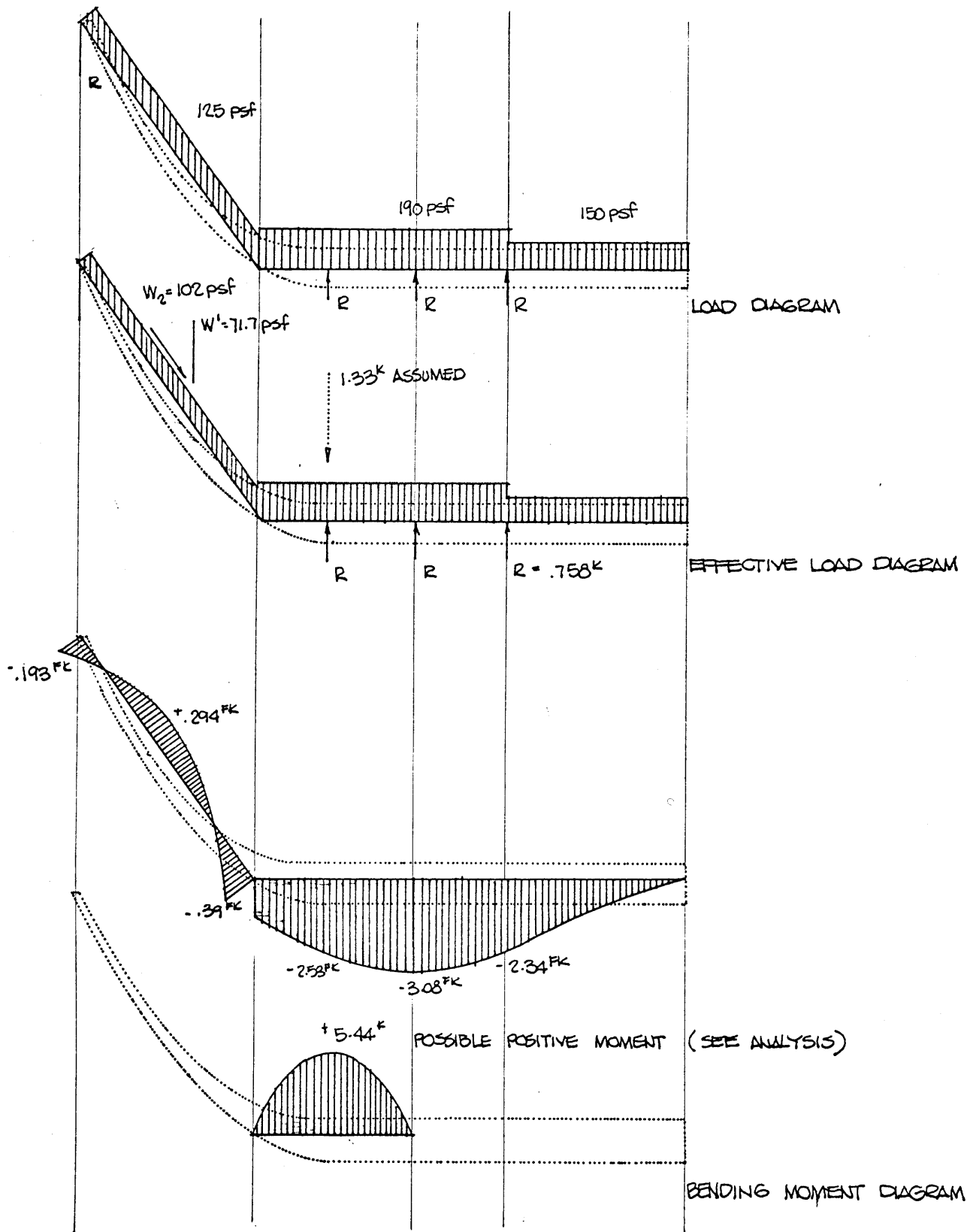

REINFORCING STEEL REQUIREMENTS

LOWER STRUCTURE

COLUMN STRIP

$$\begin{aligned} \text{POSITIVE B.M.} &= 147 \text{ FK} \\ \text{PER RIB} &= 42 \text{ FK} \end{aligned}$$

$$A_s = \frac{42}{1.55 \times 13.5} = 2.1 \text{ IN}^2$$

USE 3 #8 BARS

$$\begin{aligned} \text{NEGATIVE B.M.} &= 85.4 \text{ FK} \\ \text{PER RIB} &= 24.4 \text{ FK} \end{aligned}$$

$$A_s = \frac{24.4}{1.55 \times 13.5} = 1.17 \text{ IN}^2$$

USE 2 #4 + 1 #8 BARS

EDGE STRIP

$$\begin{aligned} \text{POSITIVE B.M.} &= 74 \text{ FK} \\ \text{PER RIB} &= 29.6 \text{ FK} \end{aligned}$$

$$A_s = \frac{29.6}{1.55 \times 13.5} = 1.41 \text{ IN}^2$$

USE 2#7 + 1 #4 BARS

$$\begin{aligned} \text{NEGATIVE B.M.} &= 9.84 \text{ FK} \\ \text{PER RIB} &= 3.9 \text{ FK} \end{aligned}$$

$$A_s = \frac{3.9}{1.55 \times 13.5} = .187 \text{ IN}^2$$

USE 3-#3 BARS

NO COMPRESSION STEEL REQUIRED

SHEAR CHECK	COLUMN STRIP	$v = \frac{1.08 \times 10^4}{.86 [7 \times 15 + 2 \times 7 \times 15]} = 40 \text{ p.s.i.}$
	EDGE STRIP	$v = \frac{4.4 \times 10^3}{.86 \times 7 \times 15} = 49 \text{ p.s.i.}$

MID - STRIP

$$\text{CANTILEVER MOMENT} = 9.24 \text{ FK}$$

$$A_s = \frac{9.24}{1.55(13.5)} = .442 \text{ IN}^2$$

USE 2#4 + 1#3 BARS

$$\text{POSITIVE MOMENT POSSIBLE} = 5.44 \text{ FK}$$

$$A_s = \frac{5.44}{1.55(13.5)} = .78 \text{ IN}^2$$

USE 2#4 - 1#7 BARS

UPPER STRUCTURE

$$\text{NEGATIVE MOMENTS} \quad \begin{array}{l} .767 \text{ FK} \\ .39 \text{ FK} \end{array}$$

$$A_s = \frac{.141}{.072}$$

USE 6X12 0/0 W.W.M.

$$\text{POSITIVE MOMENT} \quad .58 \text{ FK}$$

$$A_s = \frac{.58}{1.55 \times 13.5} = .107$$

USE 6X6 1/1 W.W.M.

TEMPERATURE STEEL

LOWER STRUCTURE

$$\text{COLUMN STRIP} \quad A_s = .21 \text{ IN}^2$$

USE 3X16 2/8 W.W.M.

$$\text{EDGE STRIP} \quad A_s = .09 \text{ IN}^2$$

USE 6X16 2/8 W.W.M.

CORNER REINFORCING TO COLUMNLOAD TRANSFERRED FROM UPPER ROOF 13.5^k

AREA REQUIRED

$$\frac{13,500}{100} = 135 \text{ IN}^2$$

LOCAL BENDING $13.5 \times 4 = 54 \text{ FK}$

$$A_s = \frac{54}{1.55(13.5)} = 2.58 \text{ IN}^2$$

USE 2-#7 + 2-#8 BARS

COLUMN DESIGN

TOTAL LOAD ACTING 87^k

ASSUME SOME ECCENTRIC LOADING

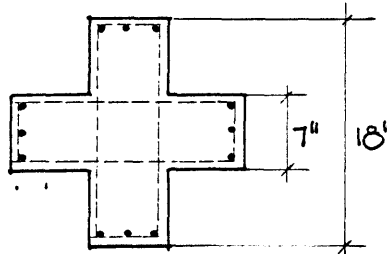
USE 18" x 18" WITH 12-#5 BARS
#2 TIES @ 7" O.C.

FOOTING DESIGN

COLUMN-FOOTING CONNECTION PINNED

SOIL CAPACITY 4000 P.S.F.

USE 6'-0" x 6'-0" x 14" DEEP
8-#6 BARS IN BOTH DIRECTIONS

2-4. FUNCTIONAL REQUIREMENTS

A. Illumination

The overhead dome is designed for the introduction of both natural and artificial light. A 3" grid ceiling is provided to diffuse the incoming light.

Additional artificial light is provided in the lower area, in the form of troughers 2' x 2' placed in the voids of the two-way system.

B. Heating and Ventilation

A forced air system is used for the conditioning of the air. It is placed in the slab, free from the structure. This grid type floor system allows an even distribution throughout the structure, with the possibility of peripheral air supply.

The system is operated from a central control plant.

C. Acoustics

The exposed concrete of the ceiling offers a reflective surface for proper sound distribution.

Reverberation time of the space ranges from 0.73 seconds when the room is occupied to 1.14 seconds when the room is unoccupied. (figure III-7). Absorbent material (140 units) is placed in the voids of the two-way system.

APPROXIMATE ABSORBENT REQUIRED

CLASSROOM VOLUME 9,100 CUBIC FEET

R_t = APPROXIMATELY 1.0 SECOND ACCEPTABLE
 Q = 445 UNITS FOR 1.0 SECOND

$$R_t = \frac{.049V}{a}$$

CLASSROOM	250 C.P.S.		500 C.P.S.		2000 C.P.S.		AREA
	α	a	α	a	α	a	
CEILING							
LOWERS	.01	.6	.02	1.2	.03	1.8	60
CONCRETE	.01	7.1	.015	10.6	.02	14.2	700
TOTAL		7.7		11.8		16.0	
LOWER CEILING							
CONCRETE	.01	.5	.015	.75	.02	1.0	50
ABSORBENT	.7	140.0	.7	140.0	.8	160.0	200
TOTAL		140.5		140.75		161.0	
FLOOR							
TILE (EXPOSED)	.03	18.0	.03	18.0	.03	18.0	600
TOTAL		18.0		18.0		18.0	
WALLS							
PLASTER	.02	18.0	.03	22.0	.04	29.0	750
GLASS	.25	62.0	.18	44.5	.07	17.0	250
TOTAL		77.0		66.5		46.0	
STUDENTS	.61	245.0	.75	300.0	.91	364.0	400
DESKS	.34	136.0	.40	160.0	.38	152.0	400

WITH STUDENTS 488.2 537.03 605.0

REVERBERATION TIME =	.915 SEC.	.83 SEC.	.735 SEC.
----------------------	-----------	----------	-----------

WITHOUT STUDENTS = 397.2 397.03 393.0

REVERBERATION TIME =	1.18 SEC.	1.12 SEC.	1.14 SEC.
----------------------	-----------	-----------	-----------

FIGURE III-7

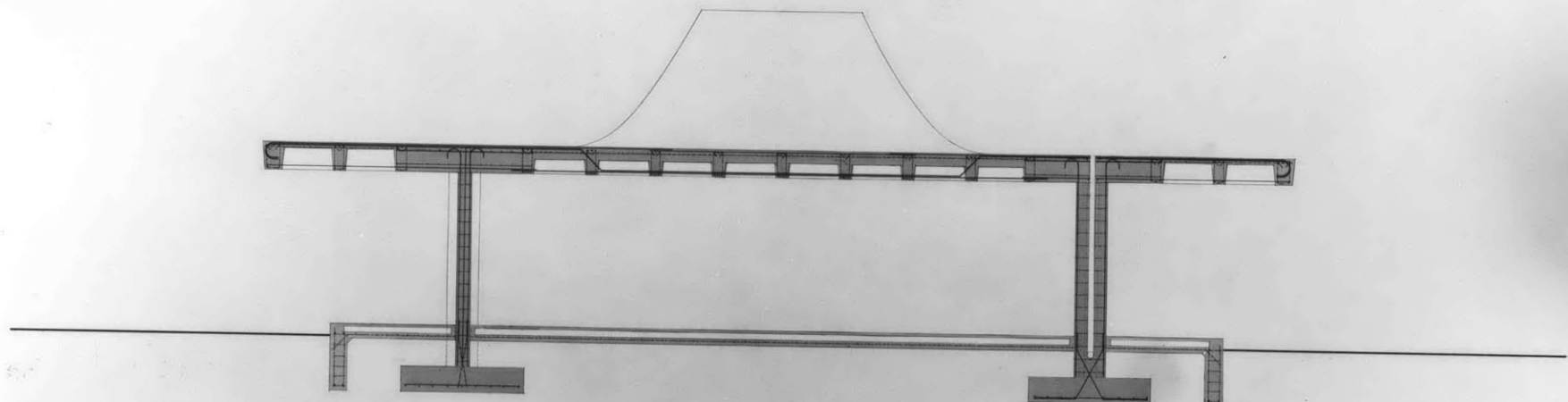

SECTION A-A OF REINFORCING

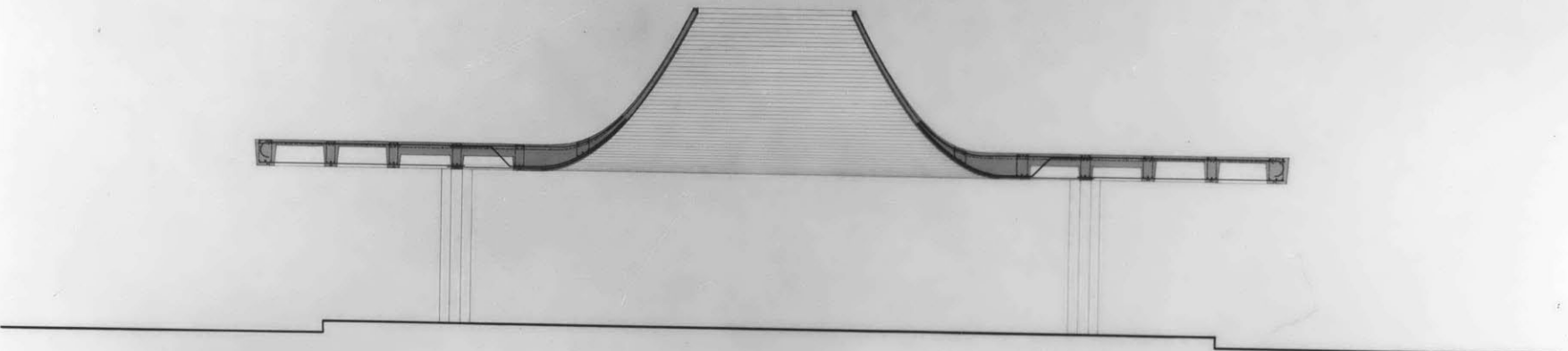

SECTION B-B OF REINFORCING

A REINFORCED CONCRETE MODULAR ROOF UNIT
 MASTER IN ARCHITECTURE THESIS M.I.T. 1962
 PAUL A. HESSELS SHEET 8 OF 7
 SCALE 1/4" = 1'-0"

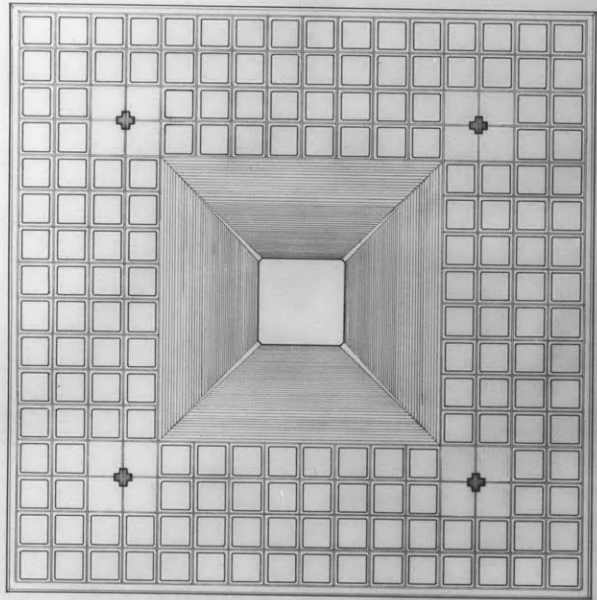

REFLECTED CEILING PLAN

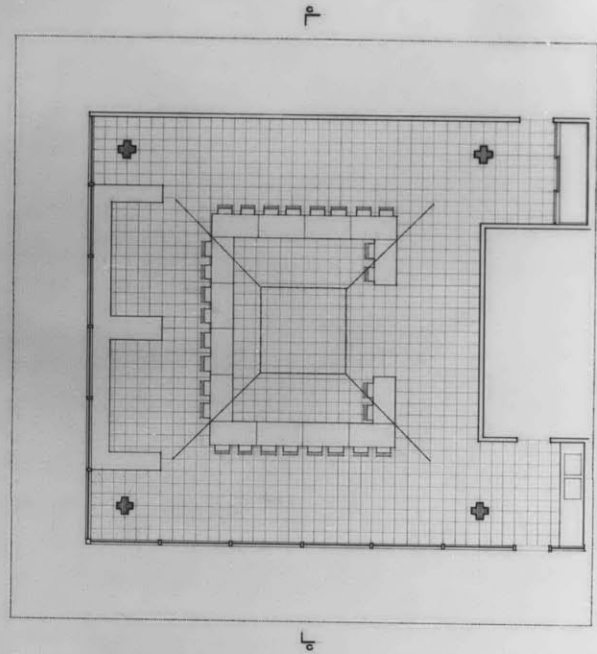

TYPICAL CLASSROOM UNIT PLAN

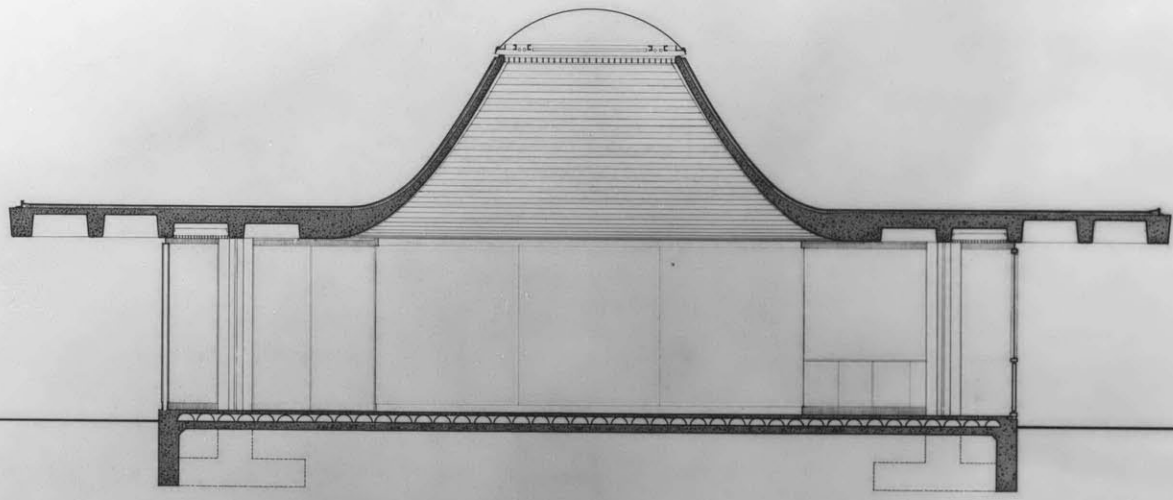

SECTION G-C OF TYPICAL CLASSROOM UNIT

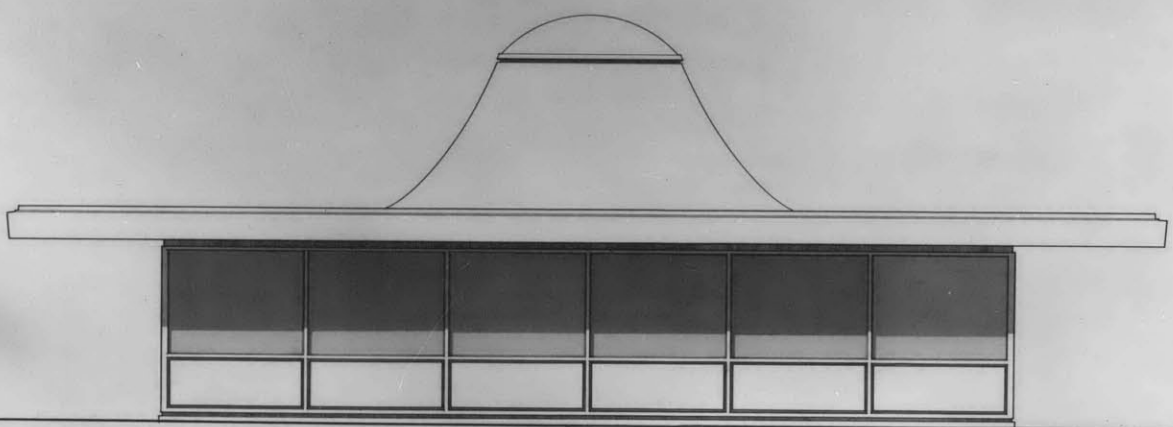

ELEVATION OF TYPICAL CLASSROOM UNIT

A REINFORCED CONCRETE MODULAR ROOF UNIT
MASTER IN ARCHITECTURE THESIS M.I.T. 1962
PIET A. KESSELS SHEET 4 OF 7
SCALE 1/8" = 1'-0"

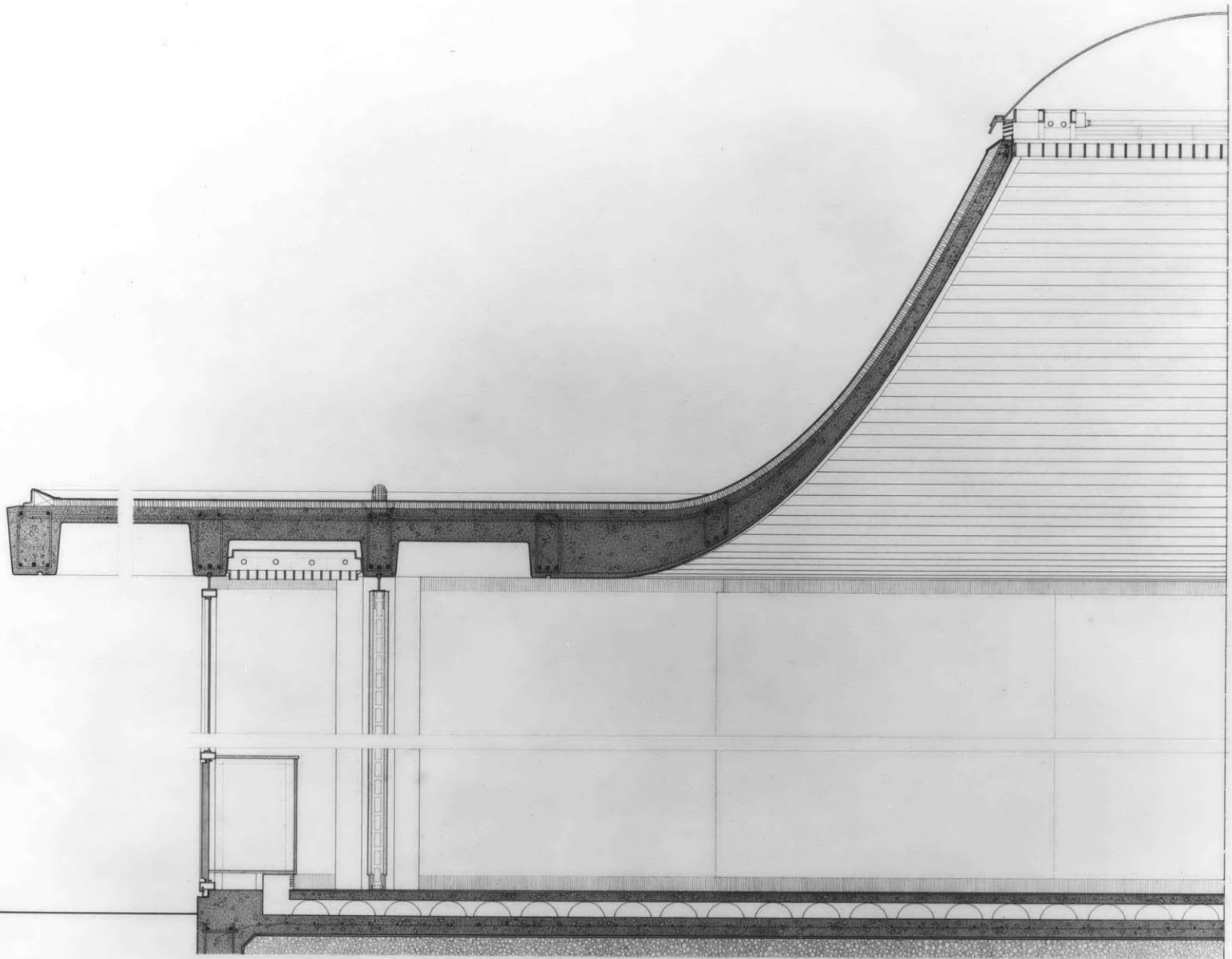

DETAIL SECTION

A REINFORCED CONCRETE MODULAR ROOF UNIT
MASTER IN ARCHITECTURE THESIS M.I.T. 1982
PIET A. HESSELS SHEET 5 OF 7
SCALE 1/8" = 1'-0"

24

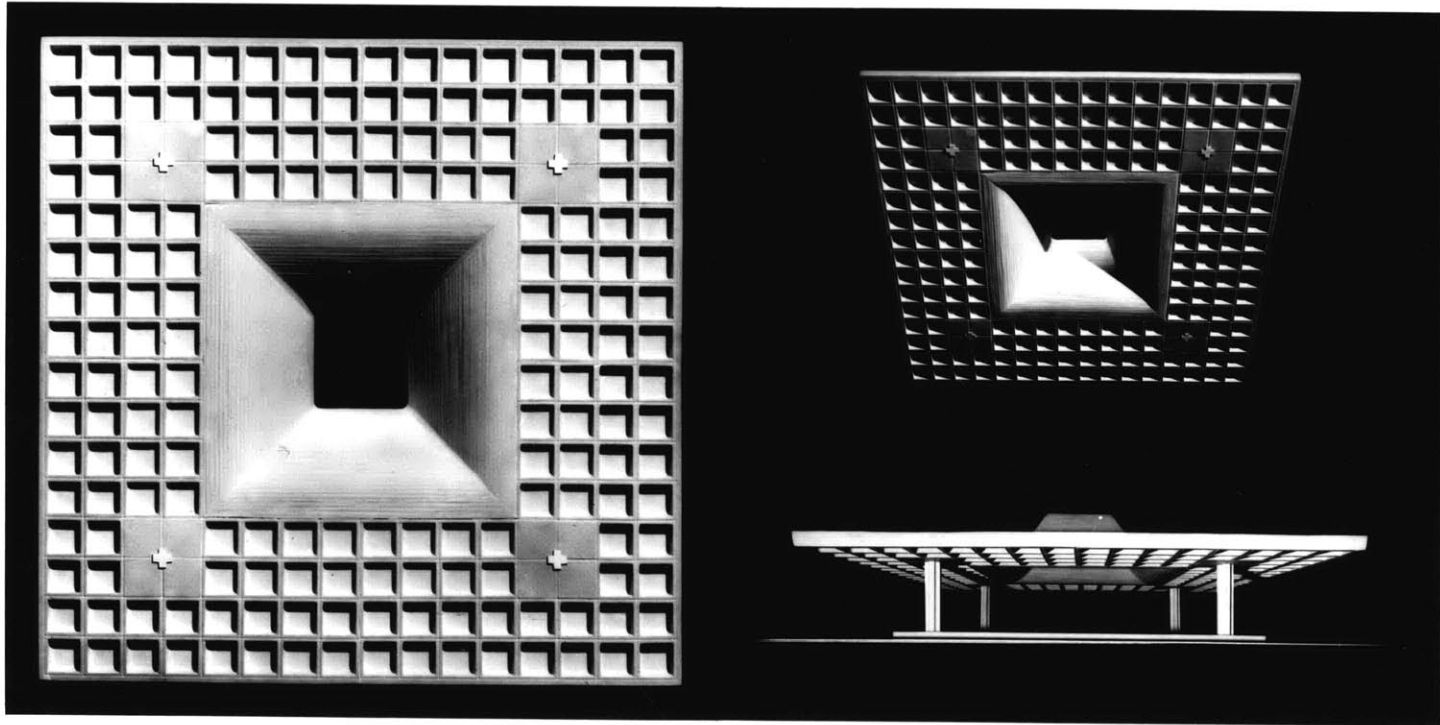

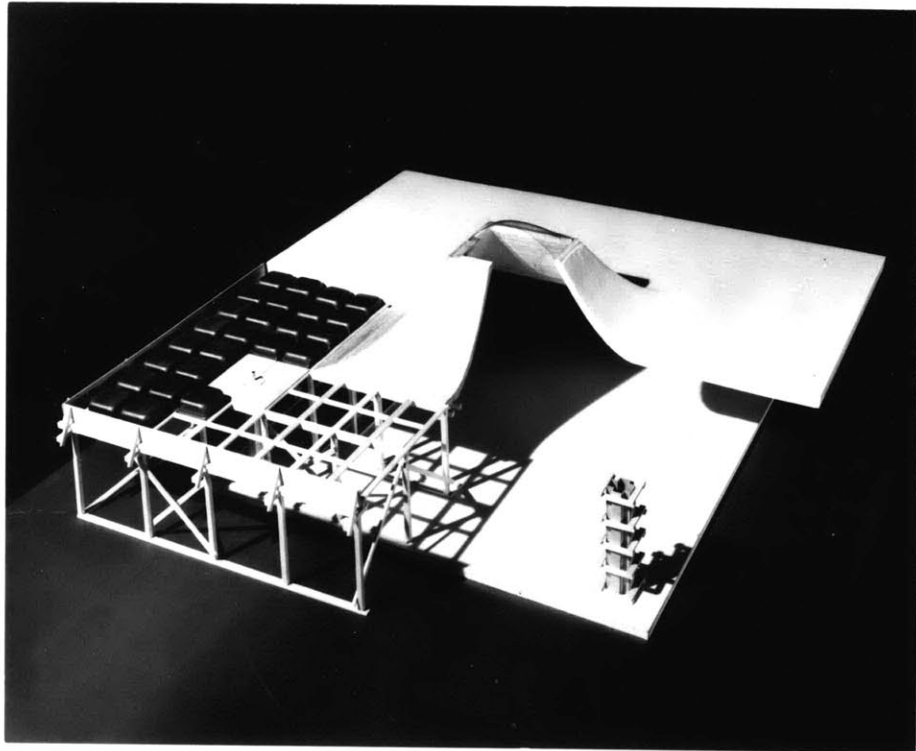

IV. DESIGN PROPOSAL

A Reinforced Concrete Modular Roof Unit, Its Application
to Schools in Canada.

by

DONALD M. MATSUBA

1. STUDY NO. 1

1-1 Description

Study No. 1 consists of a roof which has an autoclastic surface, surrounded by a low, two-way ribbed slab. (see figure IV-1). Both roofs are combined into a single system and supported by four columns.

The autoclastic structure is formed by a series of straight generating lines from the circular frame which is located vertically, down to a square horizontal diaphragm. The two-way ribbed slab is formed with standard metal pans, and cantilevers 12 feet from the column line.

The systematized structure introduces one directional natural light through the vertical opening.

1-2 Criticism

a.) The cantilever moment of the lower slab at mid-span is rather large, and causes excessive deflection at its edge.

b.) The unsymmetrical and irregular curvature of the surface implies a structural behavior which is difficult to analyze. Thus, the structure has to be designed to accommodate such irregularities.

c.) Although the curved surface is formed by a series of straight lines, it is very difficult to construct.

d.) Introduction of natural light through the vertical roof opening into the major space, creates the problem of glare which is difficult to control.

e.) The effect of the low area surrounding the high space is not clearly expressed in the interior.

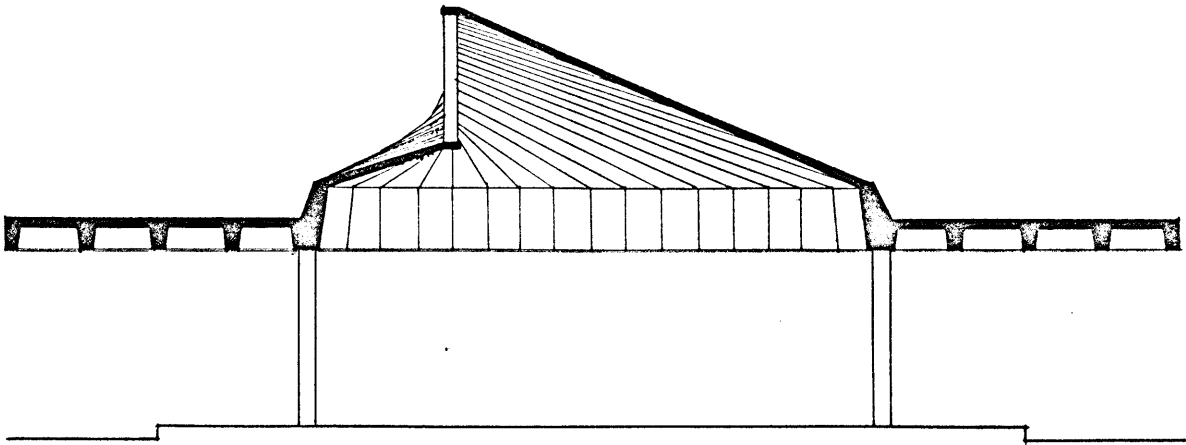

SECTION

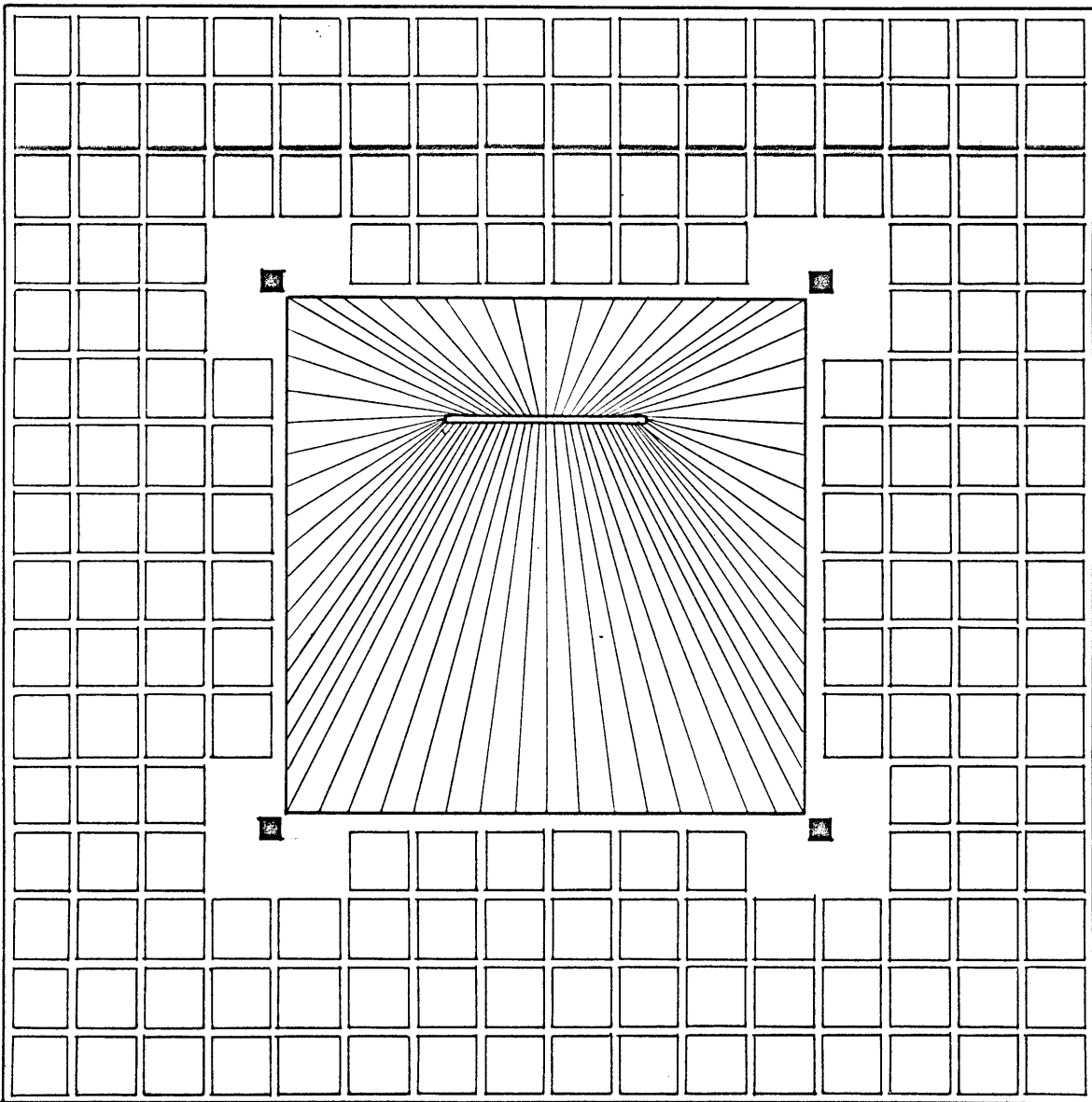

PLAN

FIGURE IV-1

2. STUDY NO. 2

2-1 Description

Study No. 2 consists of a "conoid" roof which is combined with the low, peripheral ribbed slab to form a single structural system.

The "conoid" roof is formed by a series of straight generating lines from the circular horizontal frame to a square diaphragm. The two-way slab is formed by metal pans. Columns are located 9 feet from edges of the ribbed slab, thus the cantilever distance is reduced.

The symmetrical structure simplifies the central form. Introduction of natural light through the circular opening at the top, evenly, illuminates the major space.

2-2. Criticism

a.) For a normal span of thirty feet, structural advantages of such a curved surface are not truly utilized.

b.) Although the form has been simplified from that of Study No.1, it is still difficult to construct.

c.) The circular nature of the ceiling may introduce acoustical problems.

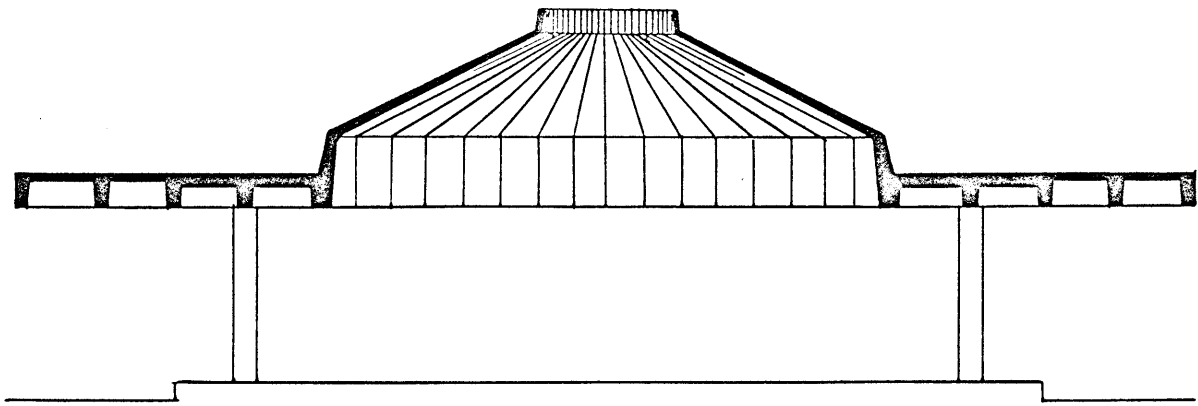

SECTION

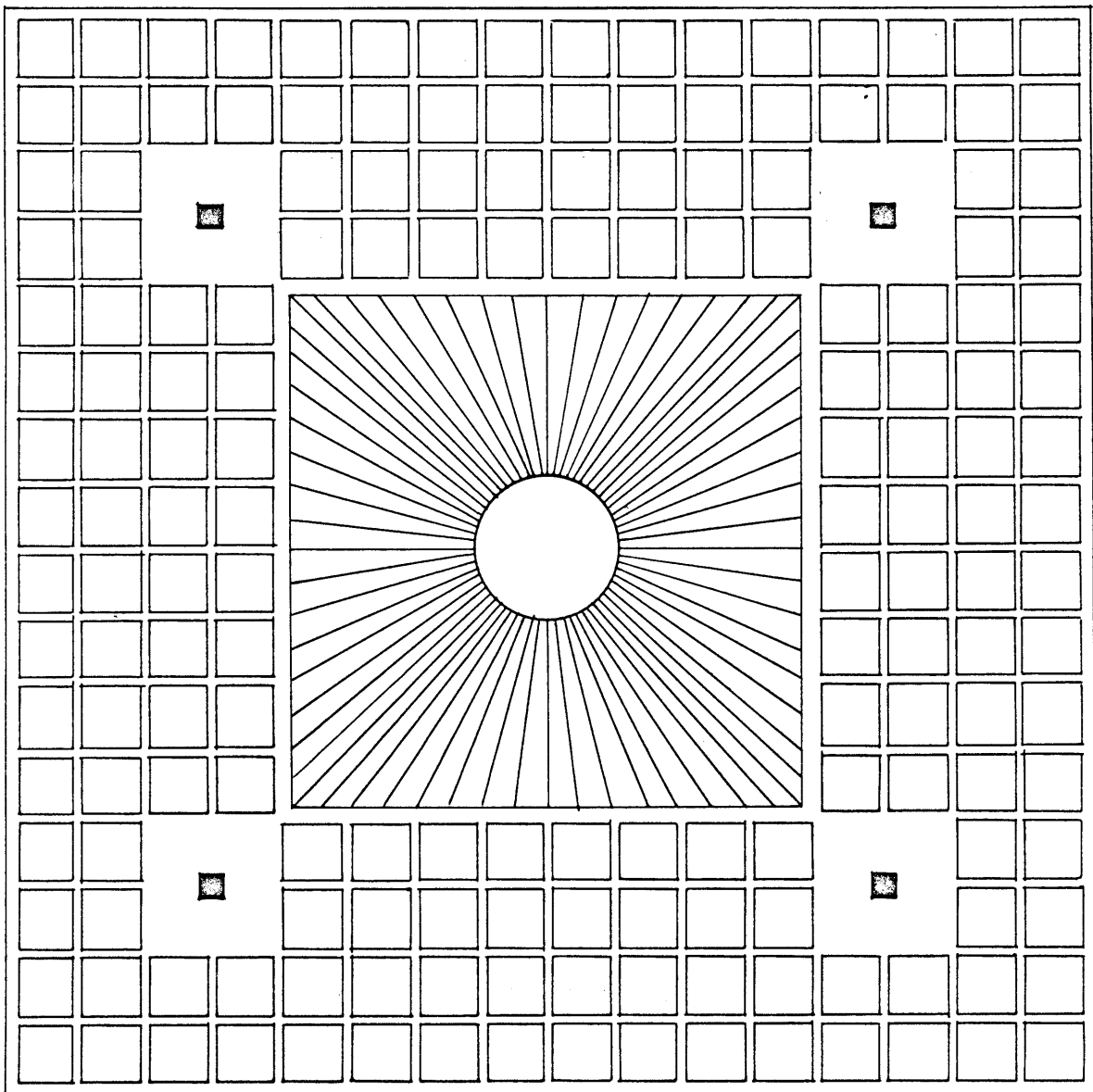

PLAN

FIGURE IV-2

3. STUDY NO. 3

3-1 Description

Study No. 3 is a structural system which consists of a truncated pyramidal roof surrounded by a low, two-way ribbed slab, and supported by four columns.

The truncated pyramidal roof, which is formed by four inclined solid slabs, behaves as a prismatic structure. It is terminated at the top with a ridge frame, and the transition to the ribbed slab is made by the diaphragm.

Each inclined plane of the prismatic roof is formed by eight sections of pre-fabricated fiber-glass plastic or metal forms. Divider strips are placed between forms to create reveals of 1" square on the bottom surface. Reveals, which are necessary for constructional tolerances, offer enrichment to the exposed concrete surface, and express the transition from the ribbed slab to the high space, and continue, reducing in scale to the square ridge frame.

The two-way ribbed slab is formed by standard 3 feet by 3 feet metal pans. Divider strips are placed between pan forms to create the 1" square reveals; thus, a module of 3 feet 1" in both directions is determined. Reveals accommodate typical head detail for partitions and exterior wall unit, and will tolerate reasonable deflection of the slab.

Columns, which are located near the corner of the unit roof (figure IV-3), are formed by four bent sections of fiber-glass plastic or metal forms. Reveals of 1" square are created by divider strips placed between forms, and are co-ordinated with those in the ribbed slab.

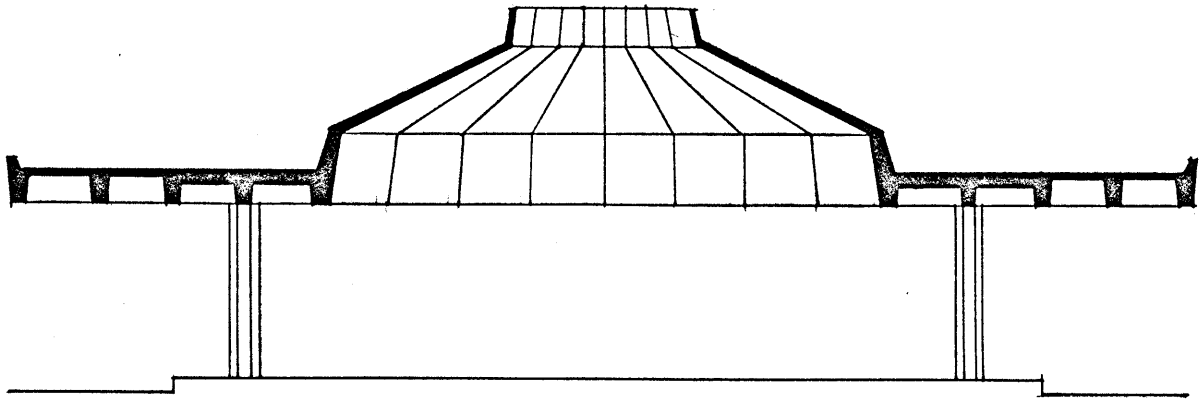

SECTION

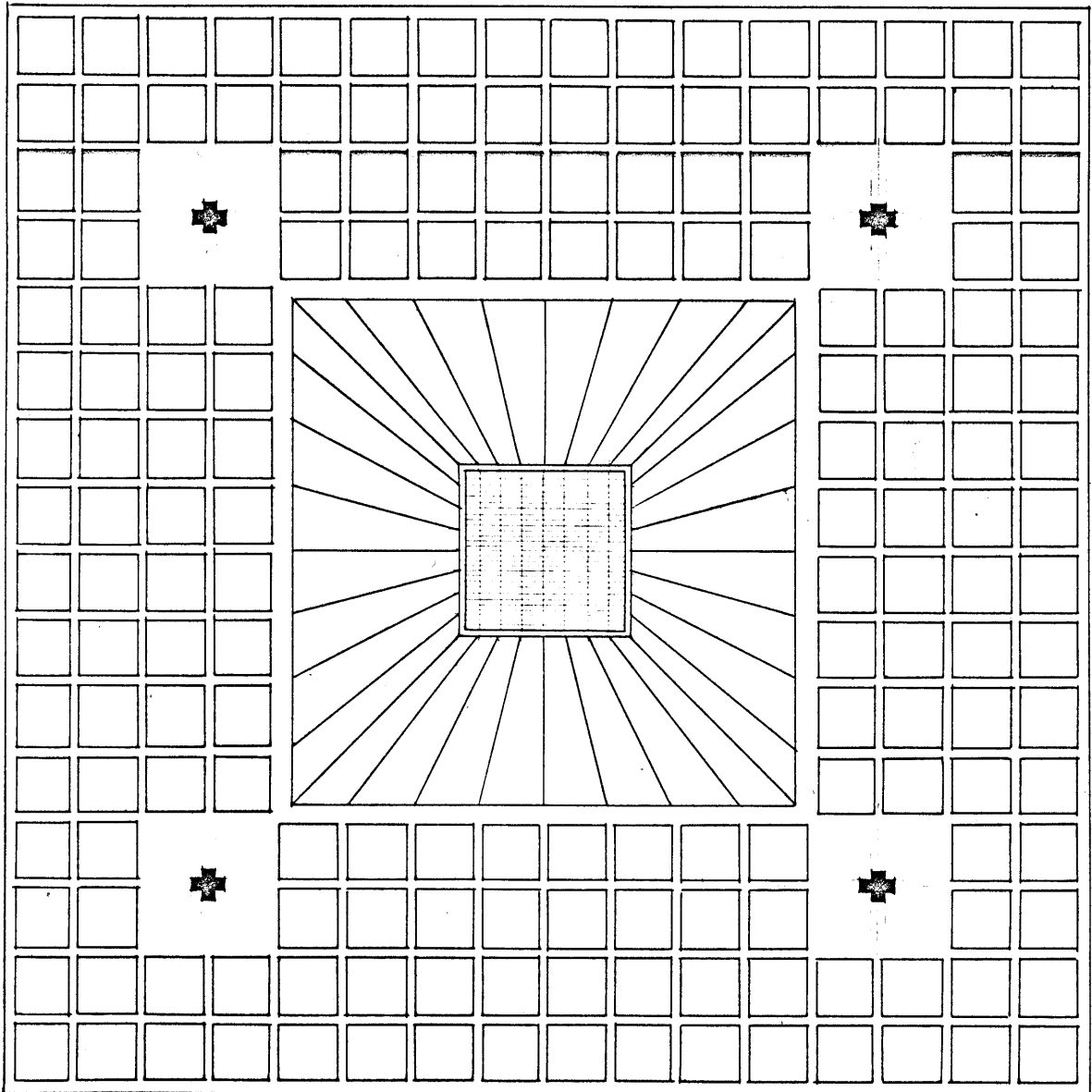

PLAN

FIGURE IV-3

3-2 Structural Analysis

Basically, the Modular Roof Unit combines the prismatic structure with the low, peripheral two-way ribbed slab, and behaves as a single system. It is supported by four columns.

The two-way ribbed slab is 15" deep spanning 30'-10". The slab cantilevers outward 9'-3" from centerlines of columns. The inner half of the ribbed slab is composed of a 7" slab on 8" ribs; the outer half is composed of a 3" slab on 12" ribs. Ribs are 7" wide. Four panels, which surround each column, are dropped to form a shear head.

The diaphragm reduces from 8" at the ribbed slab junction to 6" at the inclined slab. The angle is maintained the same as that of the ribs.

The upper slab inclines 30° to the horizontal and reduces in thickness from 6" at the base to 4" at the ridge frame.

The ridge frame defines a 8'-0" by 8'-0" skylight opening at the top of the roof. It reduces from 4" to 3" and maintains the same angle as the diaphragm.

A. Assumptions

Exact analysis of the structural system would involve major calculations, however, for preliminary design, a close approximation is determined, based on reasonable assumptions.

1.) Directional and sectional analysis of structural parts can be made prior to distributional analysis.

2.) Slab structures will behave as plates, consistent with the elastic theory.

- 3.) Inclined slabs of the prismatic structure, are supported on four sides, but restrained only on three sides.
- 4.) Three inner ribs of the low slab act as the "column" strip and the two outer ribs as the "edge" strip.
- 5.) Loads accommodated by both strips are reciprocal, or inversely proportional to their relative deflections.
- 6.) The loading is symmetrical. However, in the designing of columns, certain assumptions are made to accommodate eccentric loads.
- 7.) Eighty percent of the moment of inertia of the diaphragm is utilized in determining the moment of inertia of the column strip.
- 8.) Stresses acting on each strip are equally accommodated by its ribs.
- 9.) Total long term deflection is the sum of the live load and $2\frac{1}{2}$ times the dead load deflections.
- 10.) Unit load acting on the upper structure is 120 psf.
 Unit load acting on the column strip is 180 psf.
 Unit load acting on the edge strip is 150 psf.
 Live load is 50 psf.
 Dead load of diaphragm is 200 pounds per linear foot.
- 11.) Load carrying capacity of soil is 6,000 psf.
- 12.) Ultimate compressive strength of concrete 3,000 psi.
 Allowable stress in tensile reinforcement
 and in column reinforcing 20,000 psi.

B. Analysis

1. The Lower Slab

The load pattern, which acts on the ribbed slab, is determined by the preliminary deflection analysis of each strip. Seventy percent of the total slab load is accommodated by the column strip and thirty percent by the combination of edge strip and column strip cantilever.

The slab is analyzed in two directions.

- a.) Each strip is analyzed for stresses in the longitudinal direction (column to column).
- b.) The ribbed slab cantilever, the diaphragm and the bending of the inclined slab are analyzed in the transverse direction. By distributing moments into the diaphragm, negative moment at the bottom edge of the inclined slab is reduced considerably.

2. Upper Roof

For the purpose of analysis, all vertical and horizontal forces, which act upon the structure are decomposed into two components, one acting perpendicular to the slab and the other acting in its plane. The perpendicular component produces stresses in the slab, while the plane component is transferred by means of shear transfer to the support. The roof structure, owing to its profile and its light loading, will not have any critical stress concentrations or relevant edge effects.

3. Column Location

The most important factor in determining the exact location of columns is to relieve excess cantilever moment at the mid-span, without introducing local stresses of any critical magnitude.

Columns are located 9'-3" from edges of the slab. The cantilever moment produced can adequately be distributed over the column strip ribs and be dissipated within the diaphragm. The deflection of the slab is reduced to a tolerable magnitude(see page 63.).

4. Local Stresses

Introduction of the upper roof load off the center line of the column, produces local stresses in the shear head. However, its magnitude is small, and does not create a major problem. (see page 69.).

5. Columns

The vertical roof load, as well as the horizontal wind load acting on the roof surfaces, will introduce a non-symmetrical loading condition on the columns; thus, creating bending moment which has to be accommodated by the columns and column connections. Because the footing can only resolve bending moment into a couple of forces, causing non-uniform loading on the soil, the desired column connections are fixed at the top and pinned at the bottom.

RELATIVE DEFLECTION OF LOWER ROOF STRUCTURE

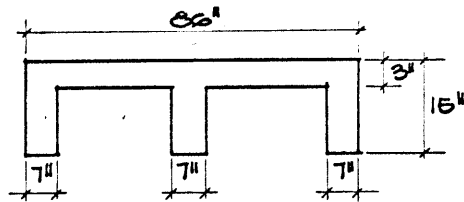
CANTILEVER COLUMN STRIP

EQUIV. SECTION

$$b = 86''$$

$$b' = 3(7) = 21''$$

$$t = 3''$$

$$h = 15''$$

$$b/b' = 4.1$$

$$t/h = .2$$

$$C = 1.7$$

MOMENT OF INERTIA

$$I = \frac{C \times b' \times h^3}{12}$$

$$= \frac{1.7 \times 21 \times 15^3}{12}$$

$$I = 10,000 \text{ IN.}^4$$

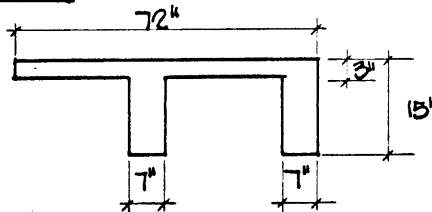
EDGE STRIP

EQUIV. SECTION

$$b = 72''$$

$$b' = 14''$$

$$t = 3''$$

$$h = 15''$$

$$b/b' = 5.2$$

$$t/h = .2$$

$$C = 1.9$$

MOMENT OF INERTIA

$$I = \frac{1.9 \times 14 \times 15^3}{12}$$

$$I = 7,6000 \text{ IN.}^4$$

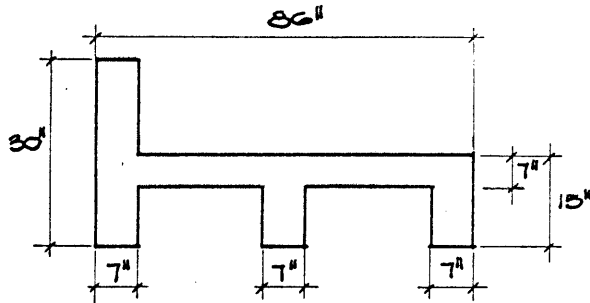
COLUMN STRIP

EQUIV. SECTION

$$\begin{aligned}
 b &= \frac{86 \times 7}{7} = 79'' \\
 b' &= 2 \times 7 = 14'' \\
 t &= 7'' \\
 h &= 15''
 \end{aligned}$$

$$\begin{aligned}
 b/b' &= 5.6 \\
 t/h &= .46 \\
 C &= 2.1
 \end{aligned}$$

MOMENT OF INERTIA

$$\begin{aligned}
 1. \quad I_1 &\rightarrow \frac{2.1 \times 14 \times 15^3}{12} \\
 &= 8,250 \text{ IN.}^4
 \end{aligned}$$

$$\begin{aligned}
 2. \quad I_2 &= \frac{b \times h^3}{12} \\
 &= \frac{7 \times 30^3}{12} \\
 &= 15,500 \text{ IN.}^4
 \end{aligned}$$

ASSUME 80%
EFFECTIVE

$$I = 12,500 \text{ IN.}^4$$

TOTAL

$$I = 20,750 \text{ IN.}^4$$

ASSUME 10,000 LBS. ACTING

CANTILEVER DEFLECTION

EFFECTIVE W = 5,000 LBS.

$$\Delta = \frac{WL^3}{3EI} \quad L = 9 \text{ FT.}$$

$$\Delta = \frac{5 \times 10^3 \times 7.29 \times 1.728 \times 10^5}{3 \times 3 \times 10^6 \times 10^4}$$

$$= .07''$$

EDGE STRIP DEFLECTION

W = 10,000 LBS.
L = 30 FT.

$$\Delta = \frac{WL^3}{76.8EI}$$

$$\Delta = \frac{10^4 \times 2.7 \times 1.728 \times 10^7}{76.8 \times 3 \times 10^6 \times 7.6 \times 10^3}$$

$$\Delta = .25''$$

COLUMN STRIP DEFLECTION

$$\Delta = \frac{10^4 \times 2.7 \times 1.728 \times 10^7}{76.8 \times 3 \times 10^6 \times 20.75 \times 10^3}$$

$$\Delta = .10''$$

RELATIVE DEFLECTION

A. CANTILEVER + EDGE STRIP = .07 + .25 = .32''

B. COLUMN STRIP = .18 = .10''

∴ LOAD TAKEN BY COLUMN STRIP = 70% (ADJUSTED)

LOAD TAKEN BY EDGE STRIP = 30%

LOADING PATTERN FOR LOWER ROOF

L.L.+D.L IN KIPS
 D.L IN ()KIPS

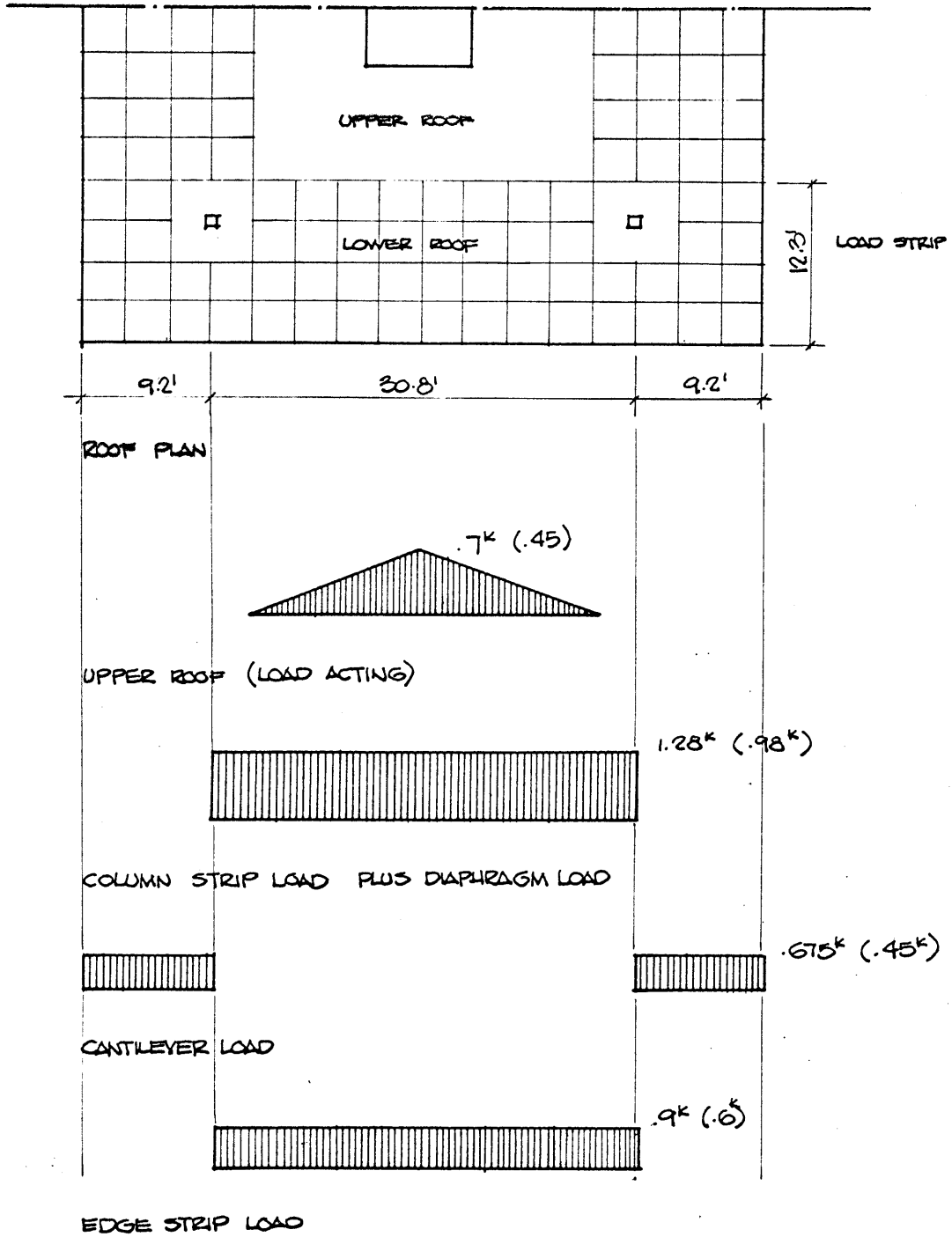

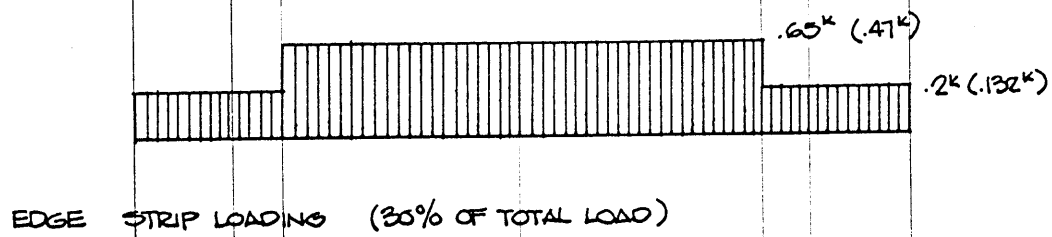
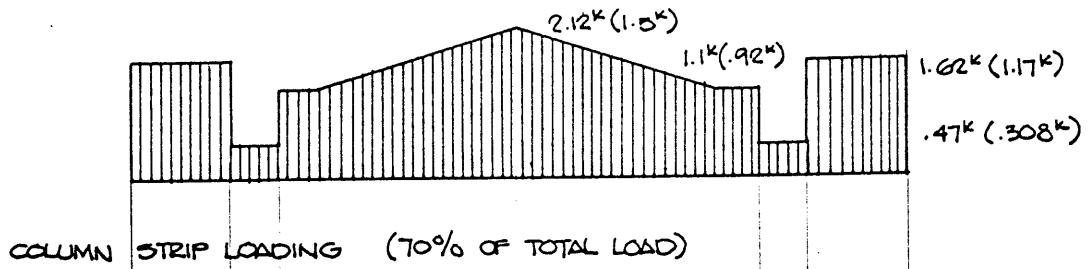

BENDING MOMENT, SHEAR AND DEFLECTION OF COLUMN STRIP

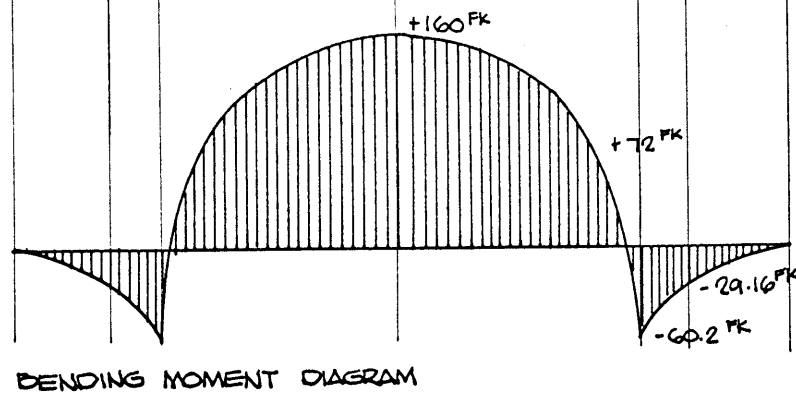
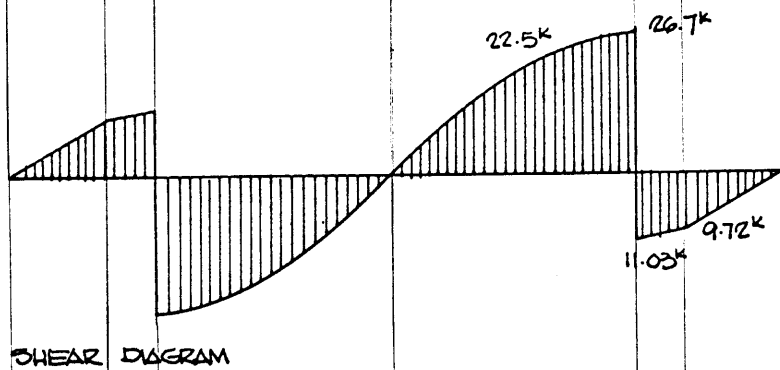

L.L + D.L. DEFLECTION OF SPAN

$$+ \Delta = \frac{WL^3}{76.8EI}$$

$$+ \Delta = \frac{49.2 \times 10^3 \times 2.9 \times 1.728 \times 10^6}{76.8 \times 5 \times 10^6 \times 20.75 \times 10^3}$$

$$+ \Delta = .5''$$

$$- \Delta = \frac{3ML^2}{48EI}$$

$$- \Delta = \frac{3 \times 60.2 \times .92 \times 144 \times 10^3 \times 12 \times 10^3}{48 \times 3 \times 10^6 \times 20.75 \times 10^3}$$

$$- \Delta = .11''$$

DEFLECTION

$$= .49 - .11 = .38$$

D.L. DEFLECTION

$$W = .4(12) + .92(30)$$

$$= 32.6^k$$

$$+ \Delta = \frac{35.7 \times 10^3 \times 2.9 \times 1.728 \times 10^6}{76.8 \times 5 \times 10^6 \times 20.75 \times 10^3}$$

$$+ \Delta = .36''$$

$$M = -44^k$$

$$- \Delta = \frac{3 \times 44 \times 10^3 \times 12 \times .92 \times 10^3 \times 144}{48 \times 3 \times 10^6 \times 20.75 \times 10^3}$$

$$- \Delta = .085''$$

DEFLECTION

$$= .36 - .085 = .275''$$

L.L + D.L. DEFLECTION

$$= .38''$$

D.L. "

$$= .275''$$

L.L. "

$$= .105''$$

SHORT TERM DEFLECTION

$$= .105''$$

LONG TERM DEFLECTION

$$= .69''$$

TOTAL LONG TERM DEFLECTION

$$= .795''$$

DEFLECTION OF COLUMN STRIP CANTILEVER

L.L. + D.L. DEFLECTION OF CANTILEVER

$$\text{UNIFORM LOAD } \Delta = \frac{WL^3}{8EI}$$

$$\Delta = \frac{4.23 \times 10^3 \times 9.23^3 \times 1.728 \times 10^3}{8 \times 3 \times 10^6 \times 10^4}$$

$$\Delta = .022''$$

CONCENTRATED LOAD (ASSUMED)

$$\Delta = \frac{Wb^2(3L-b)}{6EI}$$

$$\Delta = \frac{6.9 \times 10^3 \times 36 \times 144 \times 21 \times 12}{6 \times 3 \times 10^6 \times 10^4}$$

$$\Delta = .05''$$

$$\text{DEFLECTION} = .022 + .05 = .072''$$

D.L. DEFLECTION

$$W = 3.67K$$

$$\text{UNIFORM LOAD } \Delta = \frac{3.67 \times 10^3 \times 9.23^3 \times 1.728 \times 10^3}{8 \times 3 \times 10^6 \times 10^4}$$

$$\Delta = .019''$$

CONCENTRATED LOAD (ASSUMED)

$$\Delta = \frac{5 \times 10^3 \times 36 \times 144 \times 21 \times 12}{6 \times 3 \times 10^6 \times 10^4}$$

$$\Delta = .036''$$

$$\text{DEFLECTION} = .019 + .036 = .055''$$

$$\text{L.L. + D.L. DEFLECTION} = .072''$$

$$\text{D.L.} = .055''$$

$$\text{L.L.} = .017''$$

$$\text{SHORT TERM DEFLECTION} = .017''$$

$$\text{LONG TERM DEFLECTION} = .137''$$

$$\underline{\text{TOTAL LONG TERM DEFLECTION} = .154''}$$

BENDING MOMENT, SHEAR AND DEFLECTION OF EDGE STRIP

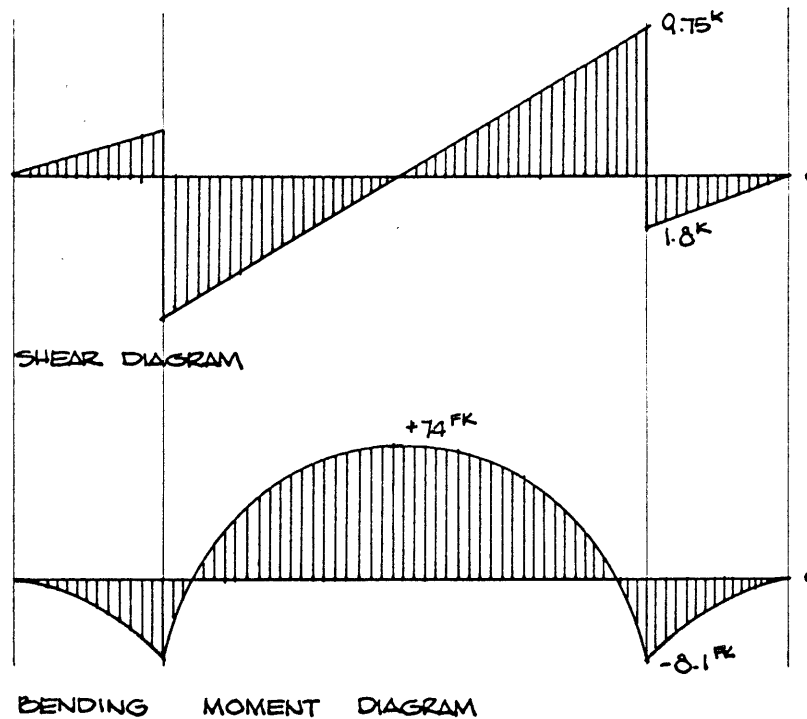
L.L. + D.L. DEFLECTION OF SPAN

$$+ \Delta = \frac{.65 \times 30 \times 10^3 \times 2.9 \times 1.728 \times 10^6}{76.8 \times 3 \times 10^6 \times 7.6 \times 10^3}$$

$$+ \Delta = .43''$$

$$- \Delta = \frac{3 \times 8.1 \times 10^3 \times 12 \times .92 \times 44 \times 10^5}{48 \times 3 \times 10^6 \times 7.6 \times 10^3}$$

$$- \Delta = .041''$$

$$\underline{\text{DEFLECTION}} = .43 - .041 = .399''$$

UPPER ROOF ANALYSIS

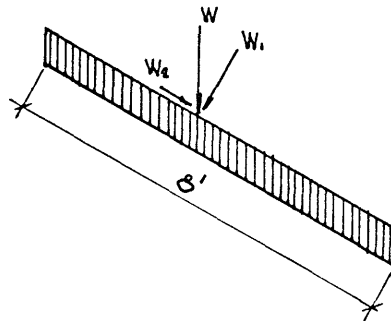
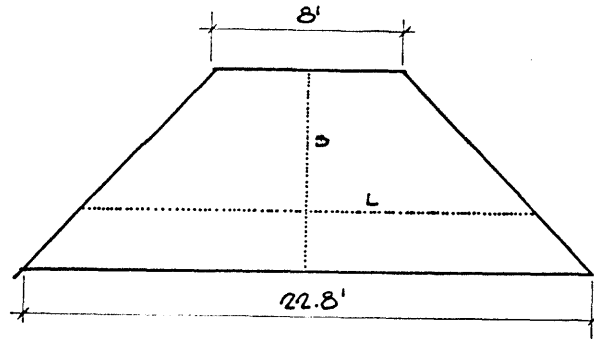

$$W = 120 \text{ p.s.f.}$$

$$W_1 = 100 \text{ p.s.f.}$$

$$W_2 = 65 \text{ p.s.f.}$$

$$S = 8'$$

$$L = 16'$$

SHORT SPAN BENDING MOMENTS

$$\text{AT RESTRAINED EDGE} = \frac{.085(100)(8^2)}{1000} = .55 \text{ FK}$$

$$\text{AT DISCONTINUOUS EDGE} = \frac{.042(100)(8^2)}{1000} = .27 \text{ FK}$$

$$\text{AT MID-SPAN} = \frac{.064(100)(8^2)}{1000} = .41 \text{ FK}$$

LONG SPAN BENDING MOMENTS

$$\text{AT RESTRAINED EDGE} = \frac{.041(100)(16^2)}{1000} = 1.02 \text{ FK}$$

$$\text{AT MID-SPAN} = \frac{.031(100)(16^2)}{1000} = .8 \text{ FK}$$

ANALYSIS OF MID-STRIP

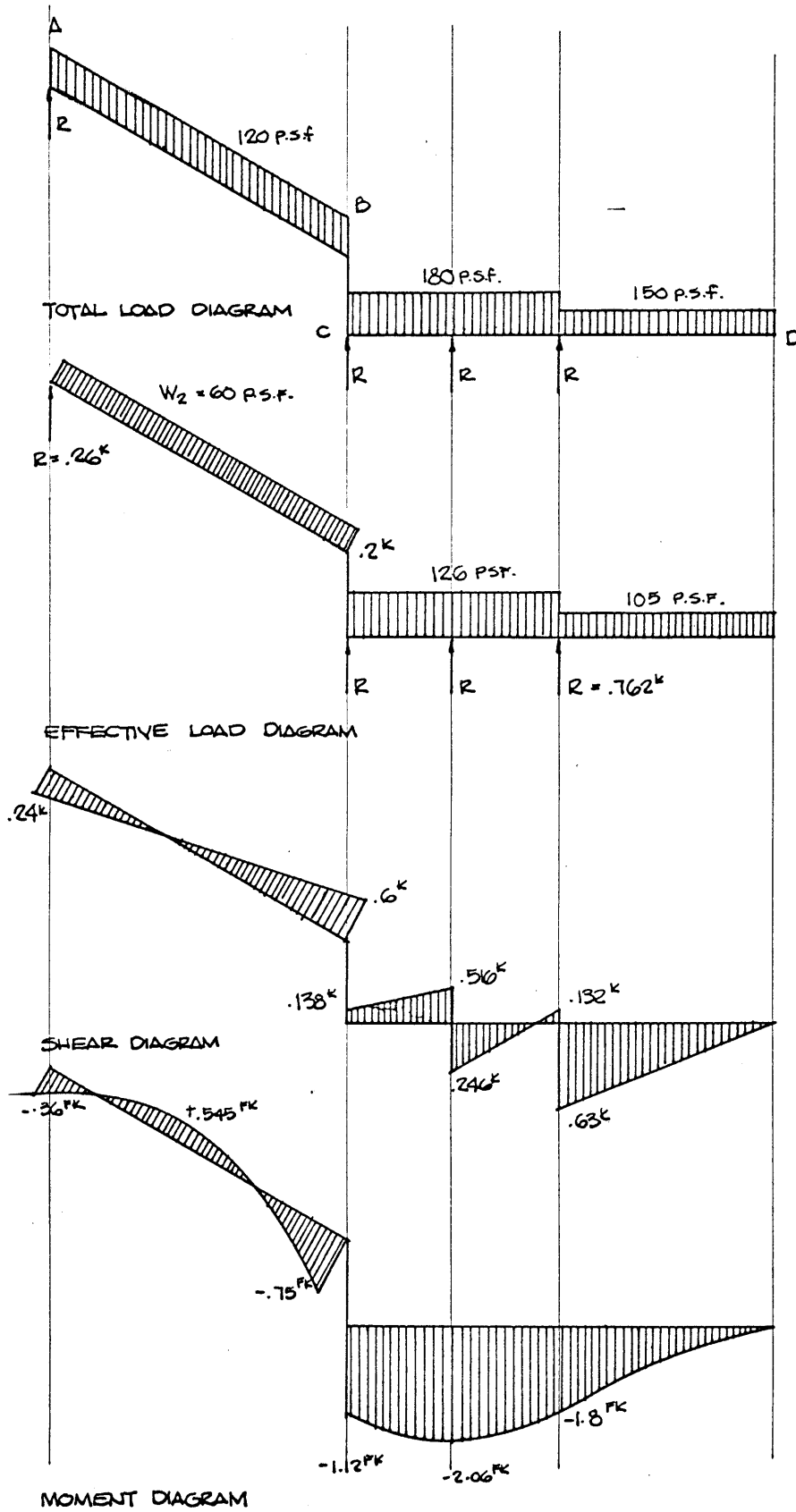

STIFFNESS FACTORS :

$$K = I/L$$

$$K_{BA} = 3.3$$

$$K_{BC} = 3/4 \times 21.4 = 16.0$$

DISTRIBUTION FACTORS

$$DF_{CB} = 1$$

$$DF_{BC} = .8$$

$$DF_{BA} = .2$$

MOMENT DISTRIBUTION

	B		C	
DF	.2	.8	1	0
B.M.	-.55 +.11	0 +.44	0 -1.12	+1.12
	+.112	-.56 +.448		
	-.328	+.328	-1.12	+1.12

ADJUSTED MOMENTS

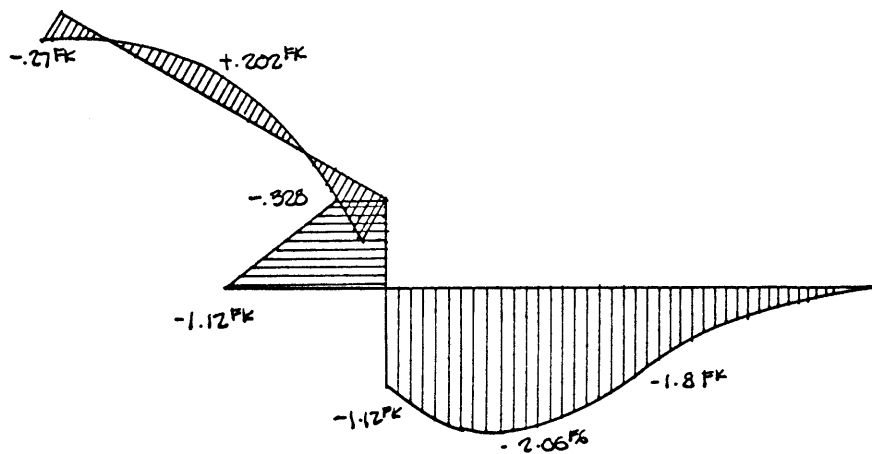

REINFORCING STEEL REQUIREMENTS

LOWER STRUCTURE

COLUMN STRIP

$$\begin{aligned} \text{POSITIVE B.M.} &= 160 \text{ FK} \\ \text{PER RIB} &= 53.3 \text{ FK} \end{aligned}$$

$$A_s = \frac{53.3}{1.55 \times 13.5} = 2.5 \text{ IN}^2$$

USE 2-#9 + 1-#7 BARS

$$\begin{aligned} \text{NEGATIVE B.M.} &= 60.2 \text{ FK} \\ \text{PER RIB} &= 20.1 \text{ FK} \end{aligned}$$

$$A_s = \frac{20.1}{1.55 \times 13.5} = 0.95 \text{ IN}^2$$

USE 2-#4 + 1-#7 BARS

EDGE STRIP

$$\begin{aligned} \text{POSITIVE BM} &= 74 \text{ FK} \\ \text{PER RIB} &= 37 \text{ FK} \end{aligned}$$

$$A_s = \frac{37}{1.55 \times 13.5} = 1.75 \text{ IN}^2$$

USE 2-#8 + 1-#5 BARS

$$\begin{aligned} \text{NEGATIVE B.M.} &= 31 \text{ FK} \\ \text{PER RIB} &= 4.05 \text{ FK} \end{aligned}$$

$$A_s = \frac{4.05}{1.55 \times 13.5} = .18 \text{ IN}^2$$

USE 1-#5 + 2-#3 BARS

NO COMPRESSION STEEL REQUIRED

SHEAR CHECK	COLUMN STRIP	$V = \frac{1.35 \times 10^4}{.86 [7 \times 16 + 2 \times 7 \times 4]}$	= 55 p.s.i.
	EDGE STRIP	$V = \frac{5 \times 10^3}{.86 \times 7 \times 15}$	= 56 p.s.i.
BOND CHECK	COLUMN STRIP	$\epsilon_s = \frac{1.35 \times 10^4}{.86 \times 15 \times 210}$	= 5.1 IN
	EDGE STRIP	$\epsilon_s = \frac{5 \times 10^3}{.86 \times 15 \times 210}$	= 1.7 IN

MID-STRIP

$$\text{CANTILEVER MOMENT} = 6.2^{\text{FK}}$$

$$A_s = \frac{6.2}{1.55(13.5)} = .3 \text{ IN}^2$$

USE 2-#4 BARS

UPPER STRUCTURE

$$\text{GOVERNING MOMENT} = 1.02^{\text{FK}}$$

$$A_s = .149 \text{ IN}^2$$

USE 6x6 0/0 W.W.M.

TEMPERATURE STEEL

LOWER STRUCTURE

COLUMN STRIP

$$A_{st} = .21 \text{ IN}^2$$

USE 3x16 2/8 W.W.M. OR 6x6 3/2

EDGE STRIP

$$A_{st} = .11 \text{ IN}^2$$

+ #3 @ 6"

USE 6x6 2/2 W.W.M.

UPPER STRUCTURE

$$A_{st} = .126 \text{ IN}^2$$

USE 6x6 0/0 W.W.M.

CHECK FOR TORSION IN COLUMN STRIP

$$\begin{aligned} I &= \alpha \cdot \frac{M}{db^2} \\ &= 3.5 \frac{2060 \times 12}{29 \times 7^2} \end{aligned}$$

$$\tau = 62 \text{ p.s.i.}$$

FOR CAUTION USE STIRRUPS #3 BAR @ 12" o.c.

CORNER REINFORCING TO COLUMNLOAD TRANSFERRED FROM UPPER ROOF 15^k

AREA REQUIRED

$$\frac{15000}{100} = 150 \text{ IN}^2$$

$$\frac{150}{15} = 10 \text{ IN}$$

$$\text{LOCAL BENDING } 15 \times \frac{3}{.77} = 57 \text{ FK}$$

$$A_s = \frac{57}{1.55(135)} = 2.5 \text{ IN}^2$$

USE 2-#7 + 2-#8 BARS

COLUMN DESIGN

TOTAL LOAD ACTING 84^k

ASSUME SOME ECCENTRIC LOADING

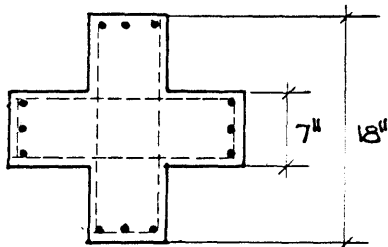
USE 18" x 18" WITH 12-#6 BARS
#3 TIES @ 6" O.C.

FOOTING DESIGN

COLUMN-FOOTING CONNECTION PINNED.

SOIL CAPACITY 6000 P.S.F.

USE 4'-2" x 4'-2" x 14" DEEP

11-#4 BARS IN BOTH DIRECTIONS

3-3. FUNCTIONAL CONSIDERATIONS

The modular roof unit for a classroom is designed to accommodate a central space of approximately 11,000 cubic feet. The quality of the space and the volume is determined mainly by considerations of illumination, heating and ventilation and acoustics.

A. Illumination

Natural light is introduced into the major space through the square skylight at the top. A plastic transmitting and diffusing shield is installed below the skylight to control the problem of glare.

Where it is required, natural light is introduced into the low area through smaller skydomes. They are installed between ribs of the "edge" strip. The location will not significantly alter the structural behavior of the slab.

For proper illumination, artificial lights are located:

- a.) within the skylight unit
- b.) at the base of the structural diaphragm
- c.) between ribs of lower area.

B. Heating and Ventilation

Unit ventilators are installed at the window sill to combat and eliminate induction of cold air draft. The system employs hot water which is supplied from a central plant, but it is individually controlled. Pipes are placed in trenches, located under floor slab of low area.

The classroom space is designed to introduce 10 cubic

feet of fresh air per student per minute² and allow a tolerable air movement of 15 feet to 65 feet per minute.³

The undesirable warm air is exhausted through vents located within the skylight unit.

C. Acoustics

The under surface of the roof, which is maintained at 30 degrees to the horizontal, is utilized to reflect sound for its proper distribution.

The reverberation time of the room has been designed for about 0.6 seconds, when the room is not occupied and 1.1 seconds, when it accommodates thirty pupils. Approximately 150 sound absorbing units are integrated with the structural diaphragm, and 230 units are co-ordinated with the two-way ribbed slab. (figure IV-4).

² National Research Council, National Building Code of Canada, 1953 part 13, p.3

³ McQuade, Walter, ed. Schoolhouse, 1958 p 185.

APPROXIMATE ABSORBENT REQUIRED

CLASSROOM VOLUME 11,000 CUBIC FEET

 R_t = APPROXIMATELY 1.0 SECOND ACCEPTABLE

$$R_t = \frac{.049V}{a}$$

a = 540 UNITS FOR 1.0 SECOND

CLASSROOM	125 C.P.S.		500 C.P.S.		2000 C.P.S.		AREA
	α	a	α	a	α	a	
CEILING							2000
LOUVERS	.01	.6	.02	1.2	.03	1.8	60
CONCRETE	.01	17.0	.015	25.5	.02	34.0	1700
* ABSORBENT	.6	144.0	.6	144.0	.7	168	240
		161.6		170.7		203.8	
LOWER CEILING							350
CONCRETE	.01	.5	.015	.75	.02	1.0	50
** ABSORBENT	.7	210.0	.8	240.0	.8	240.0	300
		210.5		240.75		241.0	
FLOOR	.02	18.0	.03	27.0	.03	27.0	900
FLOOR (WITH PUPIL)	.02	10.0	.03	15.0	.03	15.0	500
WALLS							1200
GLASS	.34	68.0	.18	36.0	.07	14.0	200
PLASTER	.01	10.0	.02	20.0	.04	40.0	1000
		78.0		56.0		54.0	
STUDENTS	.60	240.0	.80	320	.93	372	400
DESK (30)	.15	4.5	.22	6.6	.38	11.4	

WITH STUDENTS 704.6 841.05 997.2
 REVERBERATION TIME = .77 SEC. .65 SEC. .63 SEC.

WITHOUT STUDENTS 472.6 497.05 533.2
 REVERBERATION TIME = 1.13 SEC. 1.18 SEC. 1.02 SEC.

* ACOUSTIC MATERIAL SUCH AS "TECTUM"

** ACOUSTIC TILES "FIBERGLAS"

FIGURE IV-4

6. ERECTION SEQUENCE

- a. A site is prepared and individual pad footings are reinforced and concrete is poured.
- b. Trenches, perimeter foundations, columns and floor are reinforced and concrete is poured.
- c. Necessary scaffoldings are erected. The lower roof forms of metal pans are placed, reinforcings are located and concrete is poured.
- d. The upper roof's sectional fiber-glass plastic or metal forms are placed and bolted together, reinforcings are located and concrete is placed.
- e. All forms and scaffoldings are removed.
- f. Skylights and louver vents are installed.
- g. Thermal insulation and roofing material applied.
- h. Partitions, exterior walls, utility units, heating and ventilation units and storage units are installed.

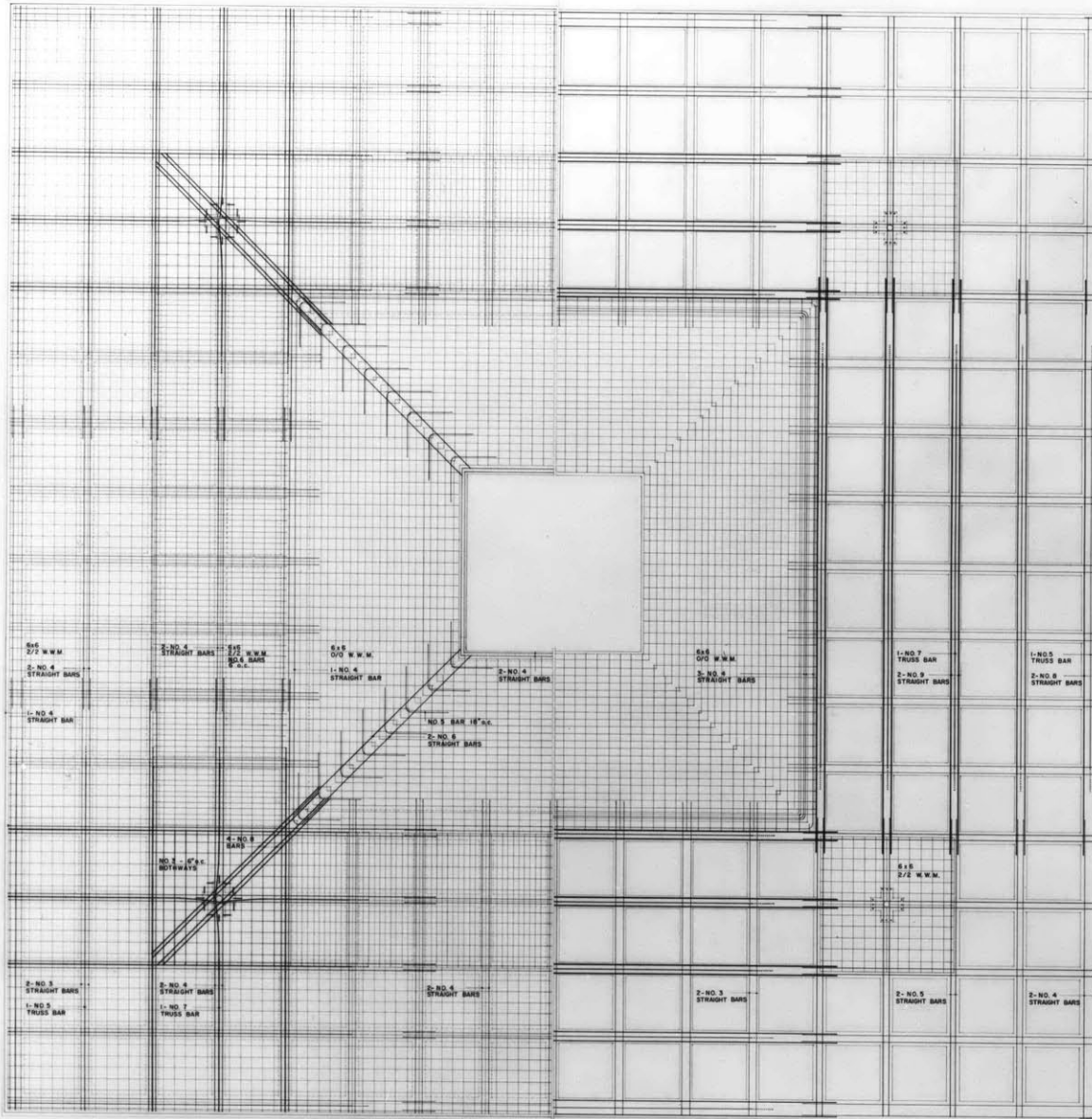

PLAN OF TOP REINFORCING

PLAN OF BOTTOM REINFORCING

71.

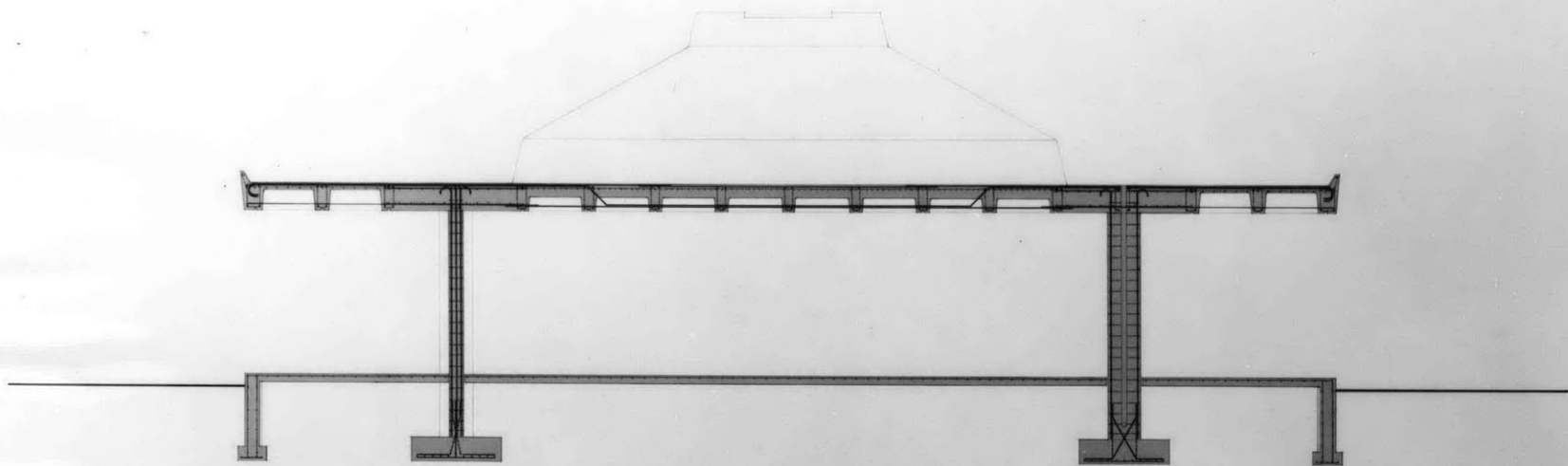

SECTION A-A OF REINFORCING

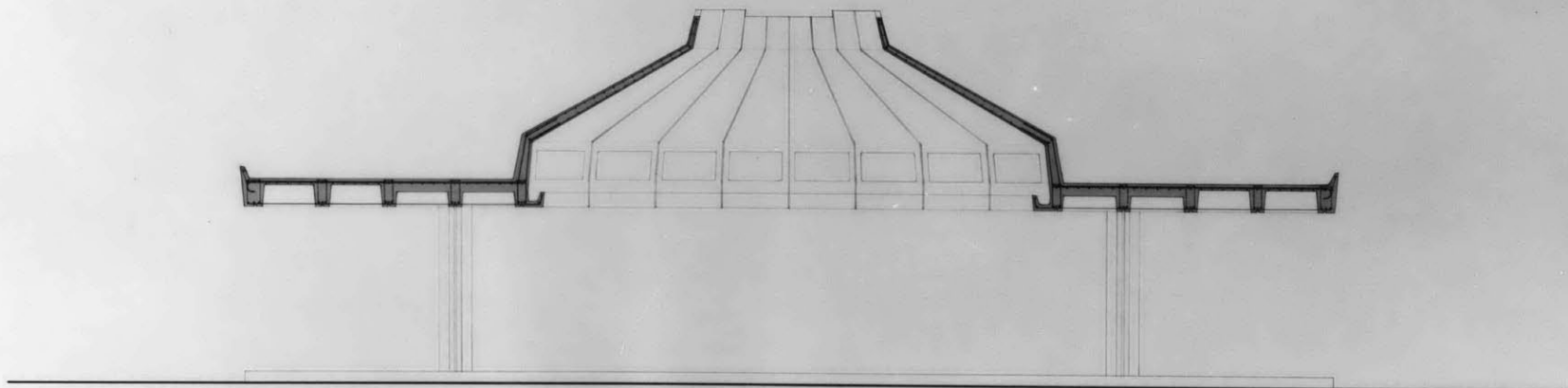

SECTION B-B OF REINFORCING

A REINFORCED CONCRETE MODULAR ROOF UNIT
 MASTER IN ARCHITECTURE THESIS M.I.T. 1988
 DONALD MICHIO MATSUDA SHEET 2 OF 4

75.

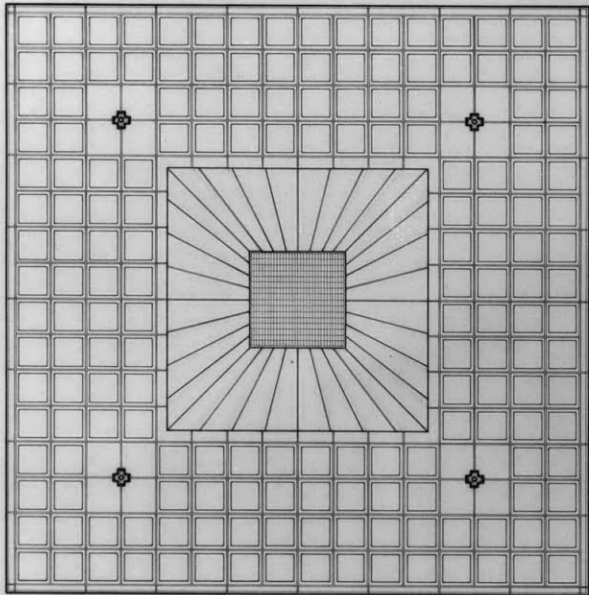

REFLECTED CEILING PLAN

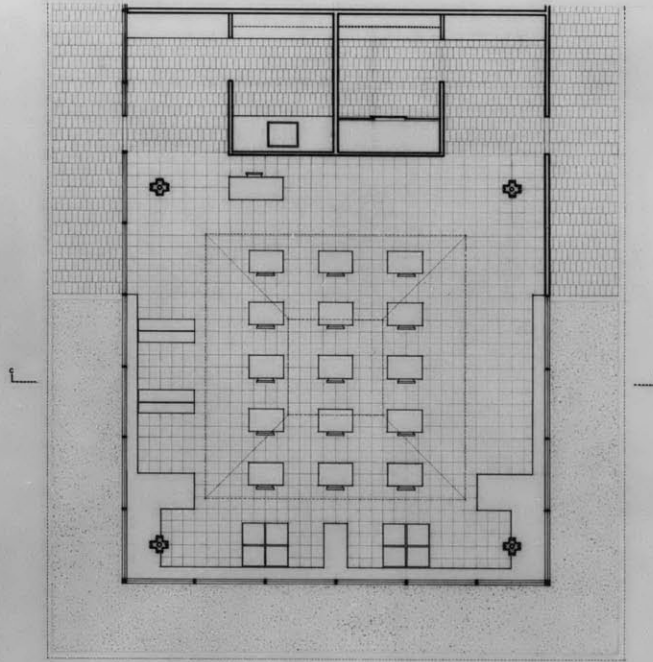

TYPICAL CLASSROOM UNIT PLAN

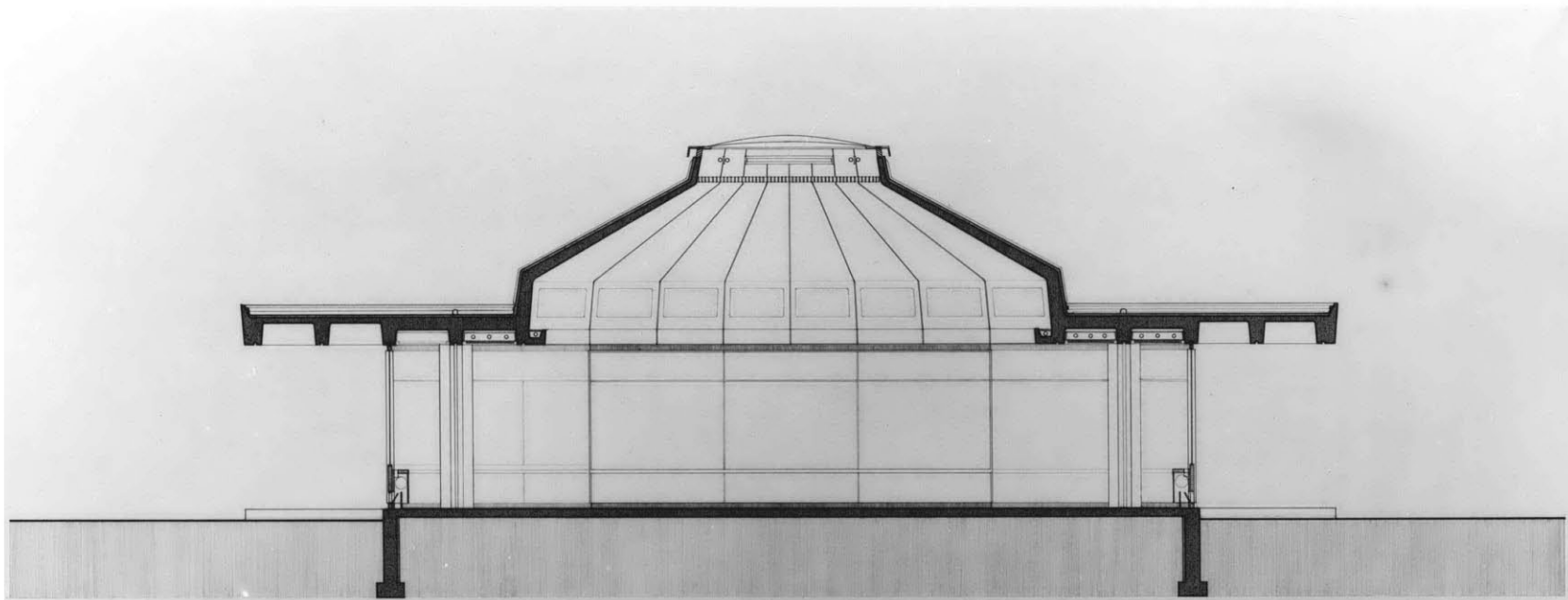

SECTION C-C OF TYPICAL CLASSROOM UNIT

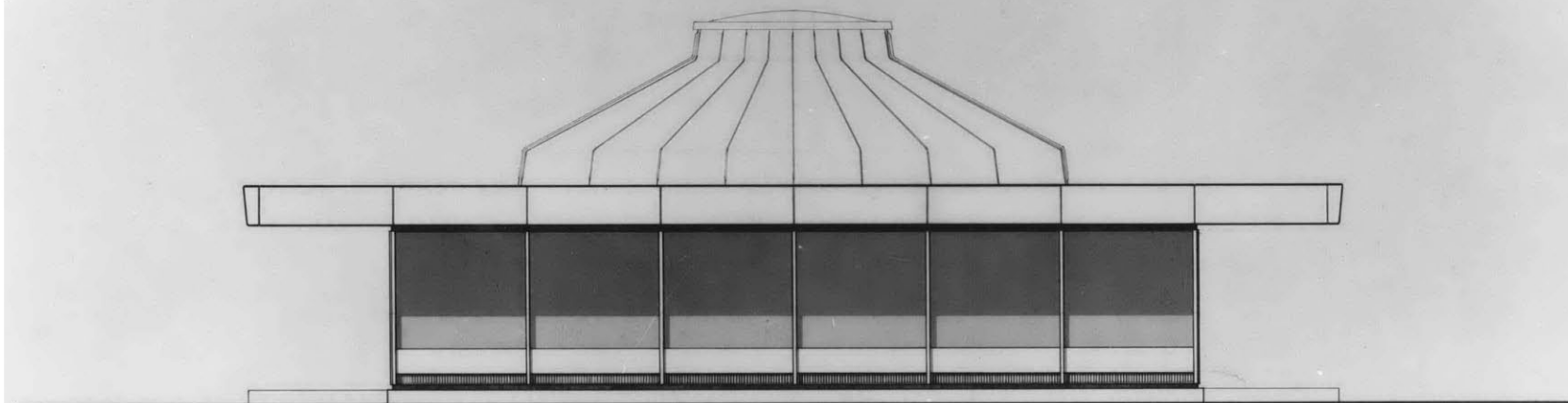

ELEVATION OF TYPICAL CLASSROOM UNIT

A REINFORCED CONCRETE MODULAR ROOF UNIT
 MASTER IN ARCHITECTURE THESIS M.I.T. 1962
 DONALD MICHIO MATSUBA SHEET 4 OF 8
 SCALE 1/8" = 1'-0"

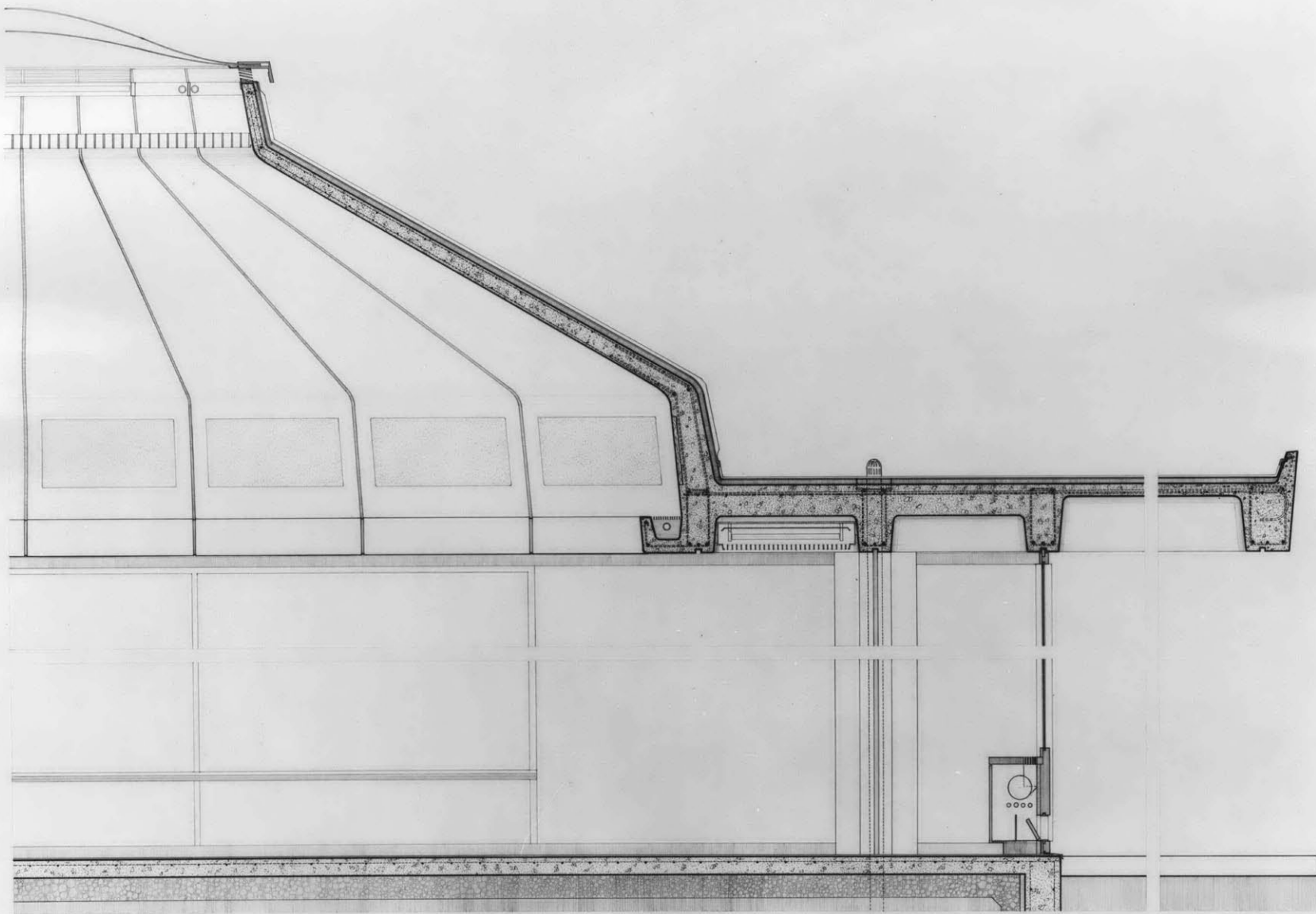

DETAILED SECTION

A REINFORCED CONCRETE MODULAR ROOF UNIT
MASTER IN ARCHITECTURE THESIS M.I.T. 1968
DONALD MICHIO MATSUBA SHEET 3 OF 8
SCALE 1/8" = 1'-0"

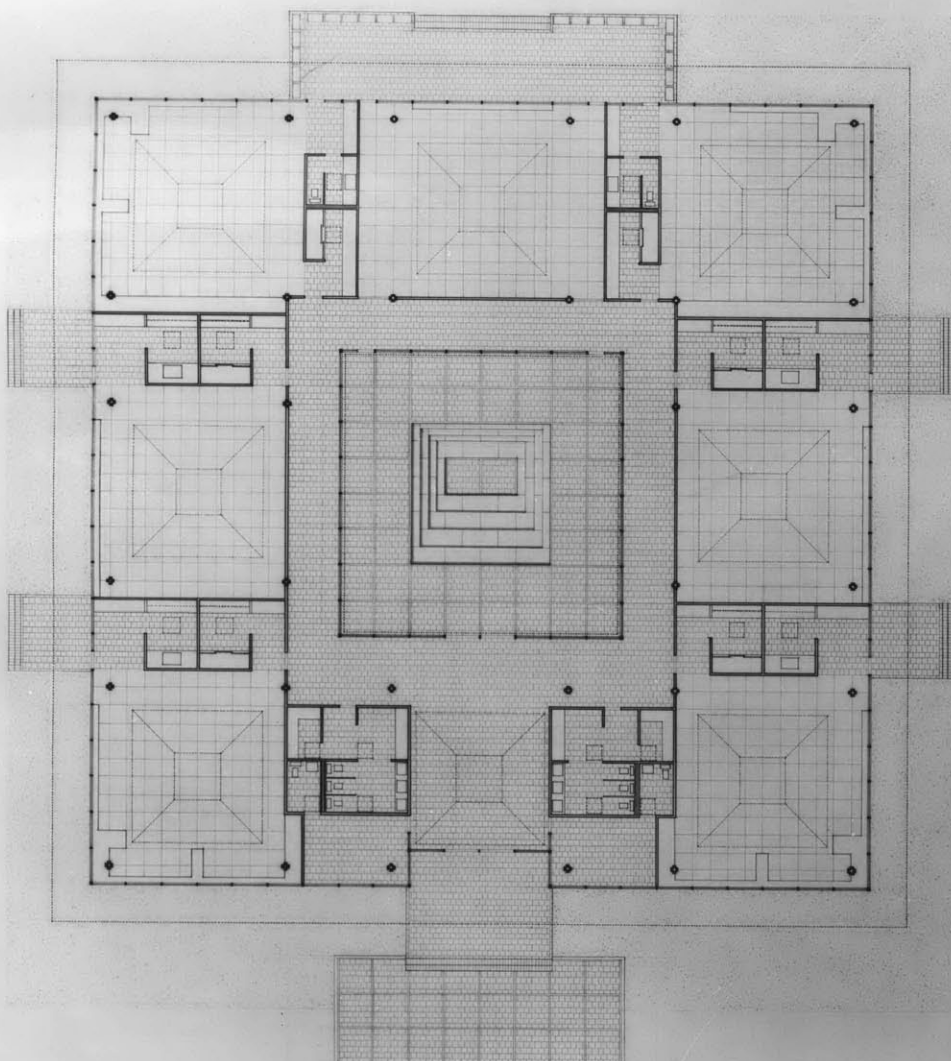

CLASSROOM ARRANGEMENT

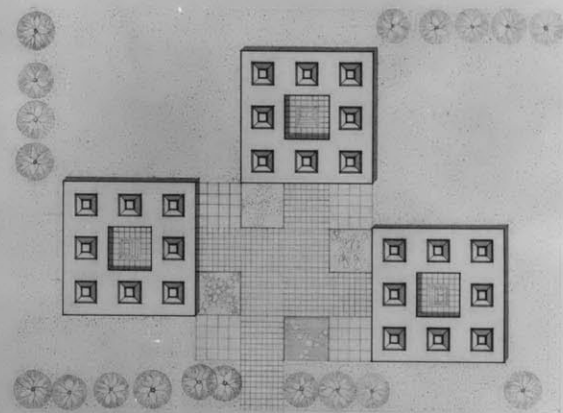

CLUSTER PLAN

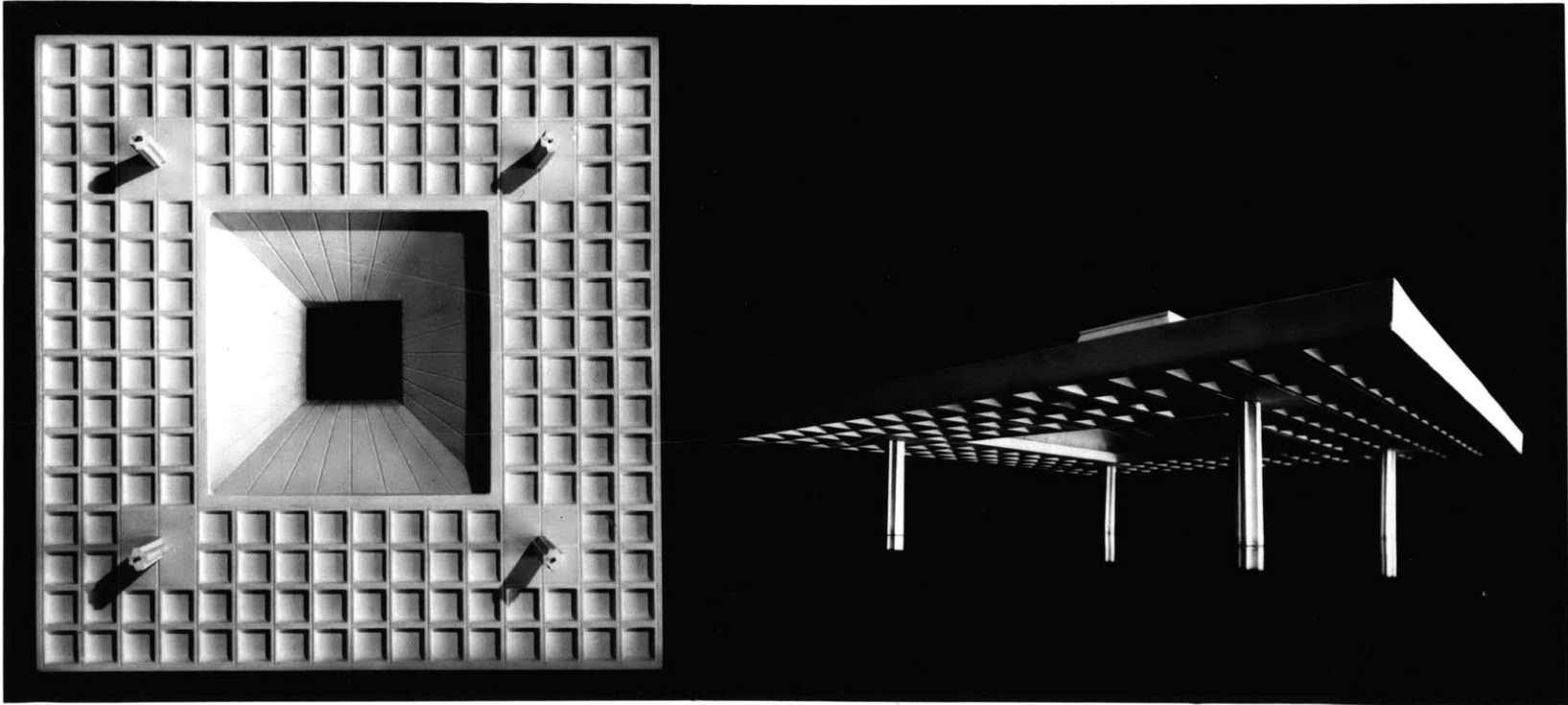

A REINFORCED CONCRETE MODULAR ROOF UNIT
MAKER IN ARCHITECTURE TODAY MID-1960S
DONALD WOOD MATSUOKA SHEET 7 OF 8

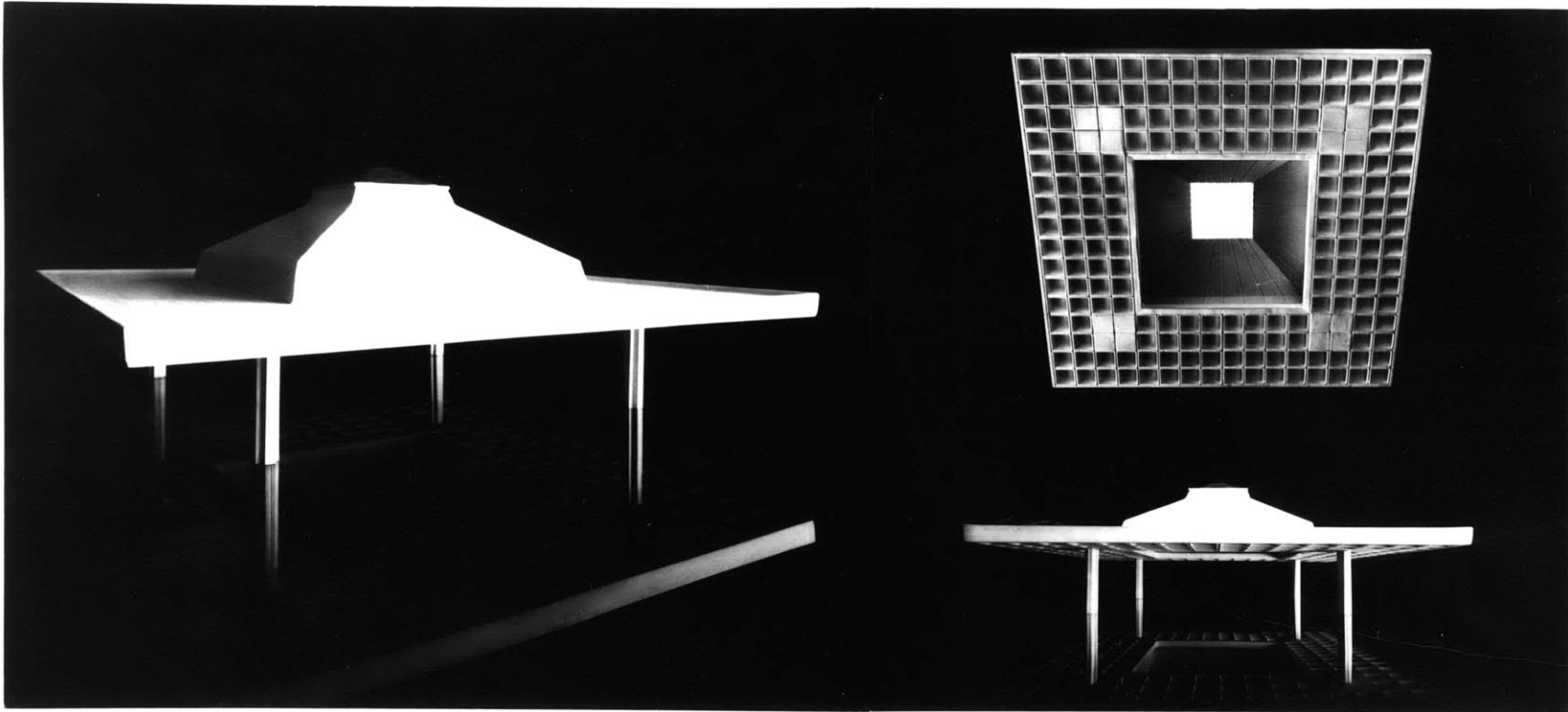

A REINFORCED CONCRETE MODULAR ROOF UNIT
MADE BY THE UNIVERSITY OF CALIFORNIA
ARCHITECTURAL MODEL BY THE UNIVERSITY OF CALIFORNIA

V. APPENDIX - RESEARCH MATERIAL

INVESTIGATION OF THE STANDARD STRUCTURAL SYSTEMS

A. PRECAST CONCRETE

1. Standard Precast Systems

a.) The double T system consists of linear elements spanning in one direction, supported on each end by either a prestressed girder or a cast in place rigid frame. (figure A-1)

b.) The channel slab system consists of slabs which span in one direction and are supported at each end.(figure A-2)

c.) The girder-purlin-plank system is composed of pre-cast concrete girders, which span between supports, and pre-cast purlins and roof planks which are supported on the girders. (figure A-3)

d.) The composite system consists of prefabricated prestressed joists, and hung-in filler blocks forming a level ceiling over which concrete is poured in place on the job site. (figure A-4)

DOUBLE T

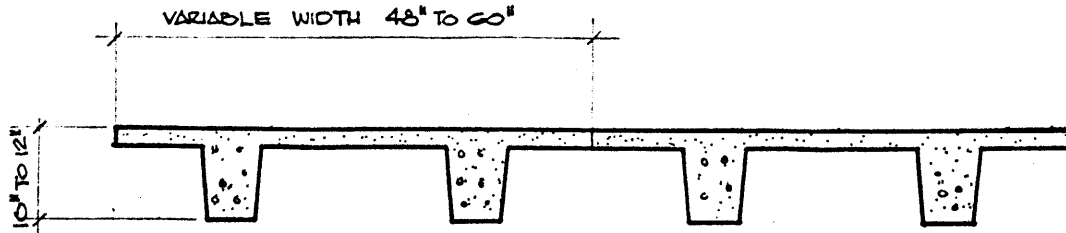

SECTION

PRETENSIONED WITH WIRE OR STRAP
SPAN LENGTH VARIABLE

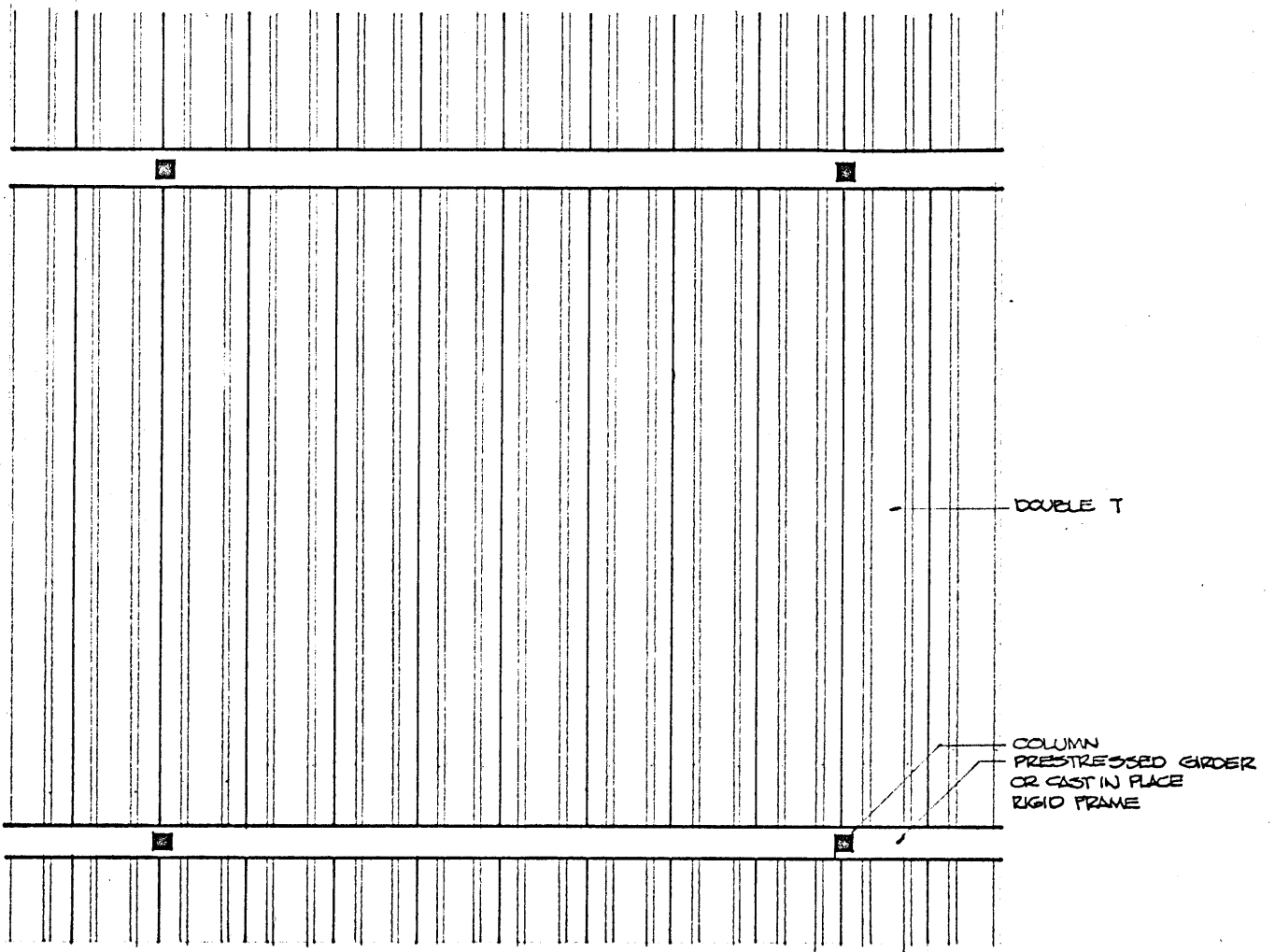

PLAN

FIGURE A-1

CHANNEL SLABS

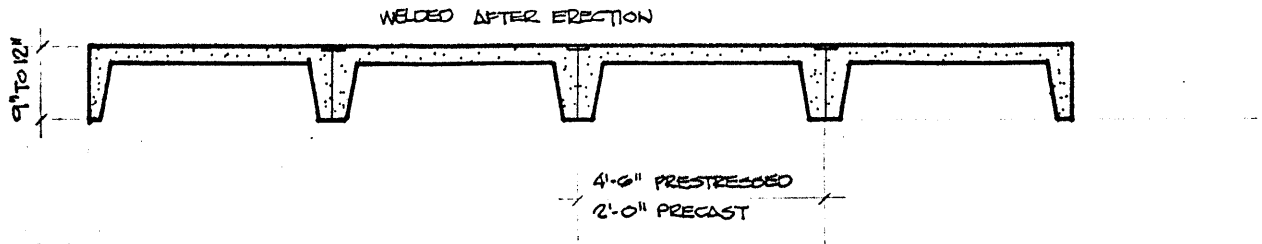

SECTION

PRECAST - 22'-0" SPAN
PRESTRESSED 40'-0" SPAN

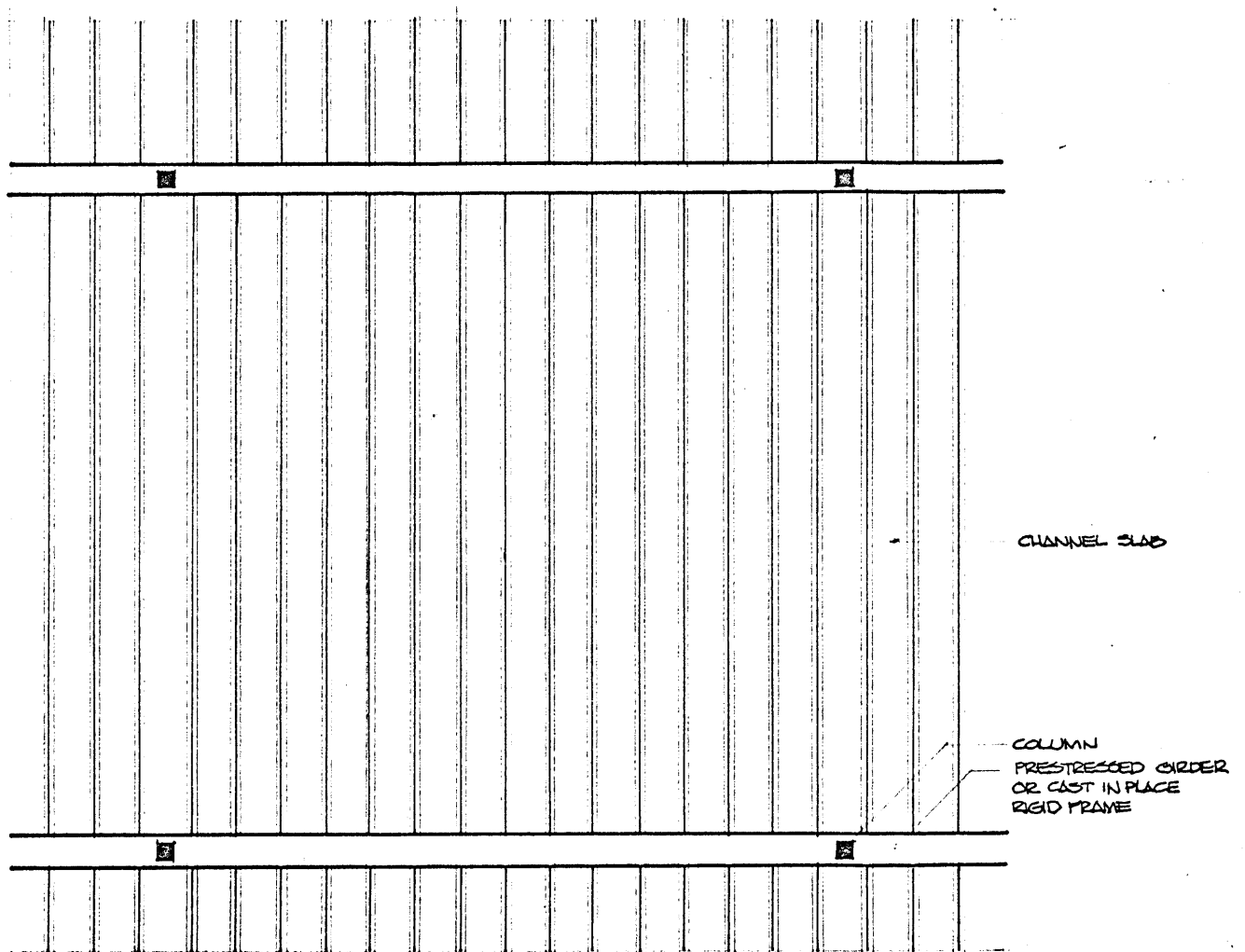

PLAN

FIGURE A-2

GIRDER - PURLIN - PLANK SYSTEM

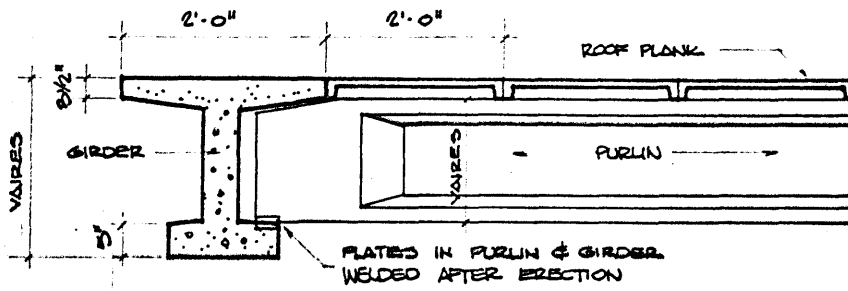

SECTION

GIRDER - 20'-0" - 50'-0" SPAN
 PURLIN - 20'-0" - 40'-0" SPAN
 PLANK - 6'-0" - 10'-0" SPAN

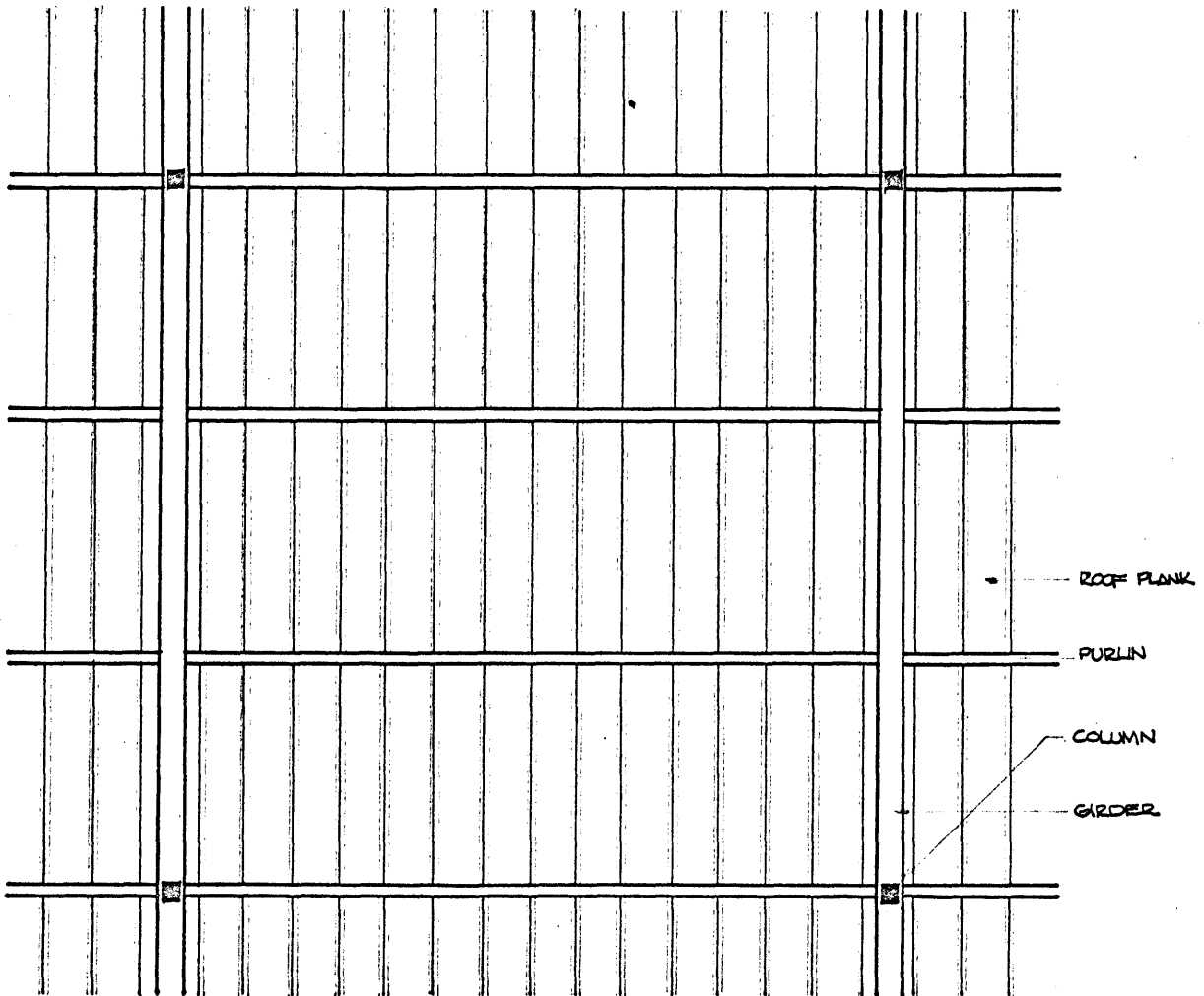

PLAN

FIGURE A-3

COMPOSITE SYSTEM

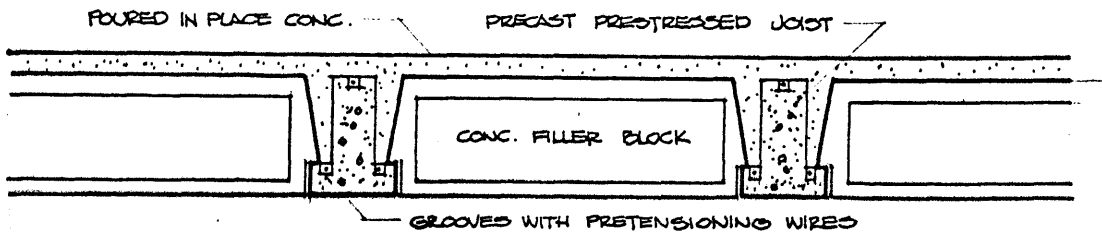

SECTION

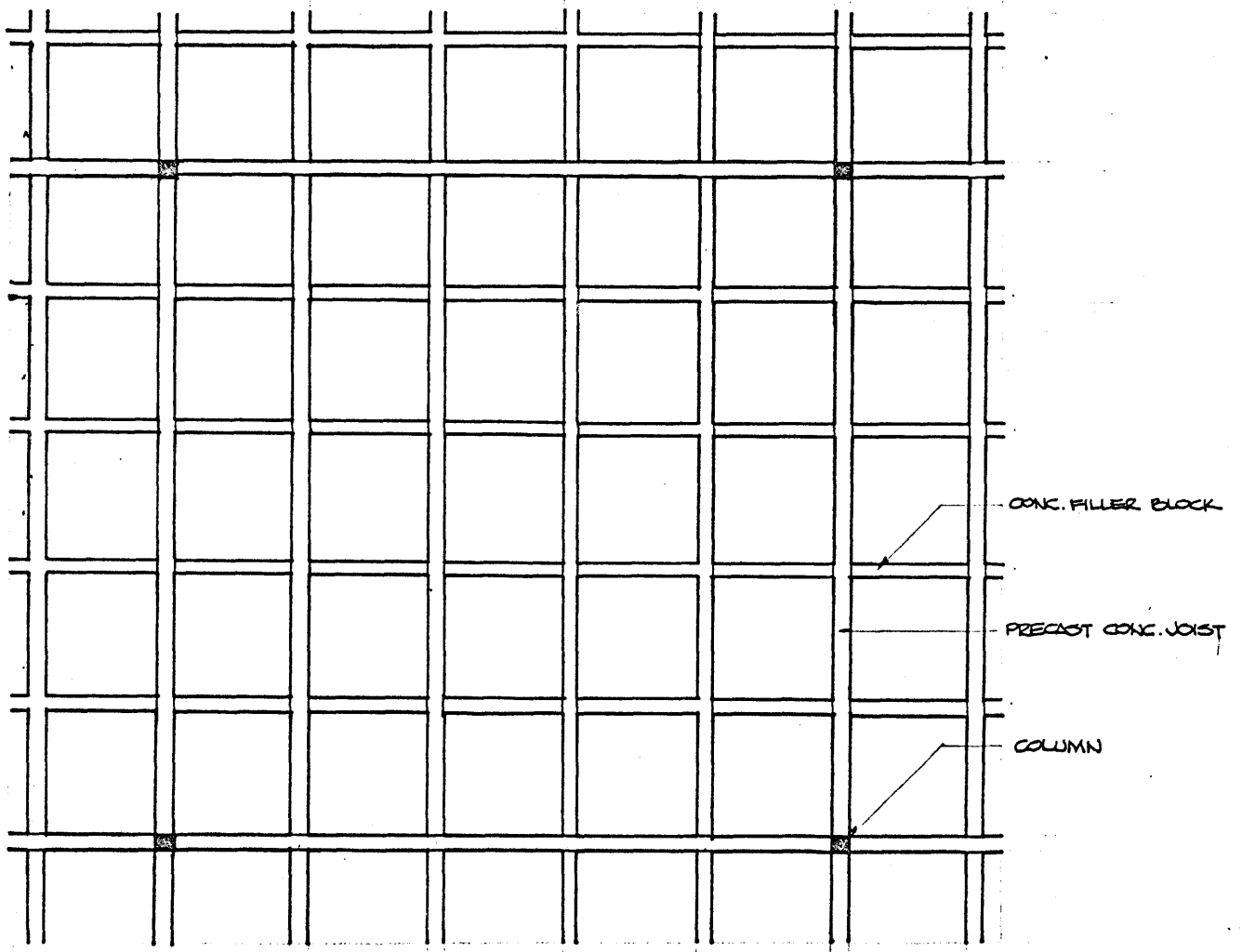

PLAN

FIGURE A-4

2. THE ADVANTAGES OF PRECAST CONCRETE STRUCTURAL SYSTEMS

a.) Economy in labour obtained by a far reaching standardization of the precast units and by the extensive employment of machinery for their manufacture and erection.

b.) Speed of erection is greatly increased. The charges for capital, overhead, and supervision on the site are correspondingly reduced.

c.) Technical control in the workshop is better than on the site, resulting in higher quality concrete and in a more accurate placing of the reinforcement. The improved quality of present articles is recognized in the building regulation of various countries by an increase in the permissible stresses.⁴

3. THE DISADVANTAGES OF PRECAST CONCRETE STRUCTURAL SYSTEMS

a.) Repeated handling of the precast units, their additional transport from the work shop to the building site, and breakage of units in transit.

b.) The difficulty of producing satisfactory connection between the precast units which will provide perfect continuity and frame effect in the finished structure equivalent to those in a monolithic structure cast in-situ.⁵

4. Billing, Kurt, Structural Precast Reinforced Concrete,
The Cement and Concrete Association p.1

5. IBID., p.2

c.) The difficulty of obtaining complete integration of services within the precast structural elements.

d.) Flexibility is limited with the use of precast structural elements.

At present standardized precast components are designed for use in one-way structural systems. Only few two-way systems have been developed which can offer the repetition of parts or the simplicity necessary for successful mass production. This shortcoming limits the possible usage of precast concrete for a modular system.

B. POURED IN PLACE CONCRETE (REPETITIVE FORMS)

The two criteria which are necessary for repetitive form work to be utilized are:

- a.) Geometric surfaces of the structure must be simple.
- b.) Design of form work must allow it to be assembled and removed easily.

1. STANDARD POURED IN PLACE CONCRETE SYSTEM UTILIZING REPETITIVE FORM WORK.

a.) One-way Joist Slabs (figure A-5)

The one-way joist system is not adaptable for a modular system because:

It requires a system of beam supports at each end.

It limits the possibility of accommodating partitions.

b.) Two-way Ribbed Slabs (figure A-6)

The two-way ribbed slab is adaptable for a modular system because:

It is directly supported by columns.

It offers the possibility of accommodating partitions in both directions.

2. THE ADVANTAGES OF POURED IN PLACE CONCRETE (REPETITIVE FORMS)

a.) The continuity of the structure utilizes the negative bending moment which is developed at the support to reduce the positive bending moment at the mid-span.

b.) Form work can be reused.

c.) It offers maximum flexibility and better tolerance for error than in precast structural units.

d.) Services can be integrated within the structure.

3. THE DISADVANTAGES OF POURED IN PLACE CONCRETE (REPETITIVE FORMS)

a. Site forming is costly and difficult.

b. When form work is large or of special condition, time of construction becomes unnecessarily long.

c. Considerable time is required for setting and curing of concrete and removing of forms.

ONE-WAY JOIST SLAB

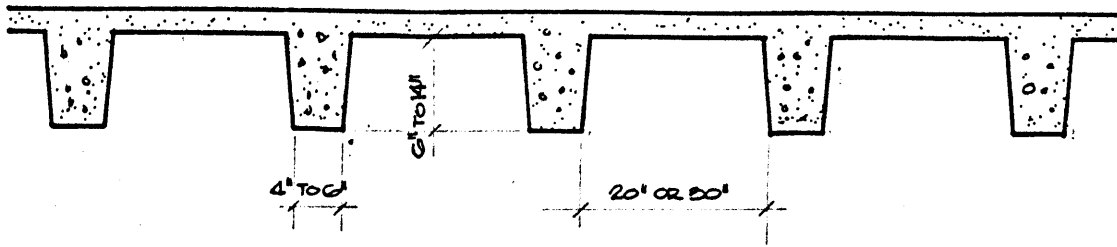

SECTION

SLAB THICKNESS - 2" ; 2½" ; 3" ; 3½"

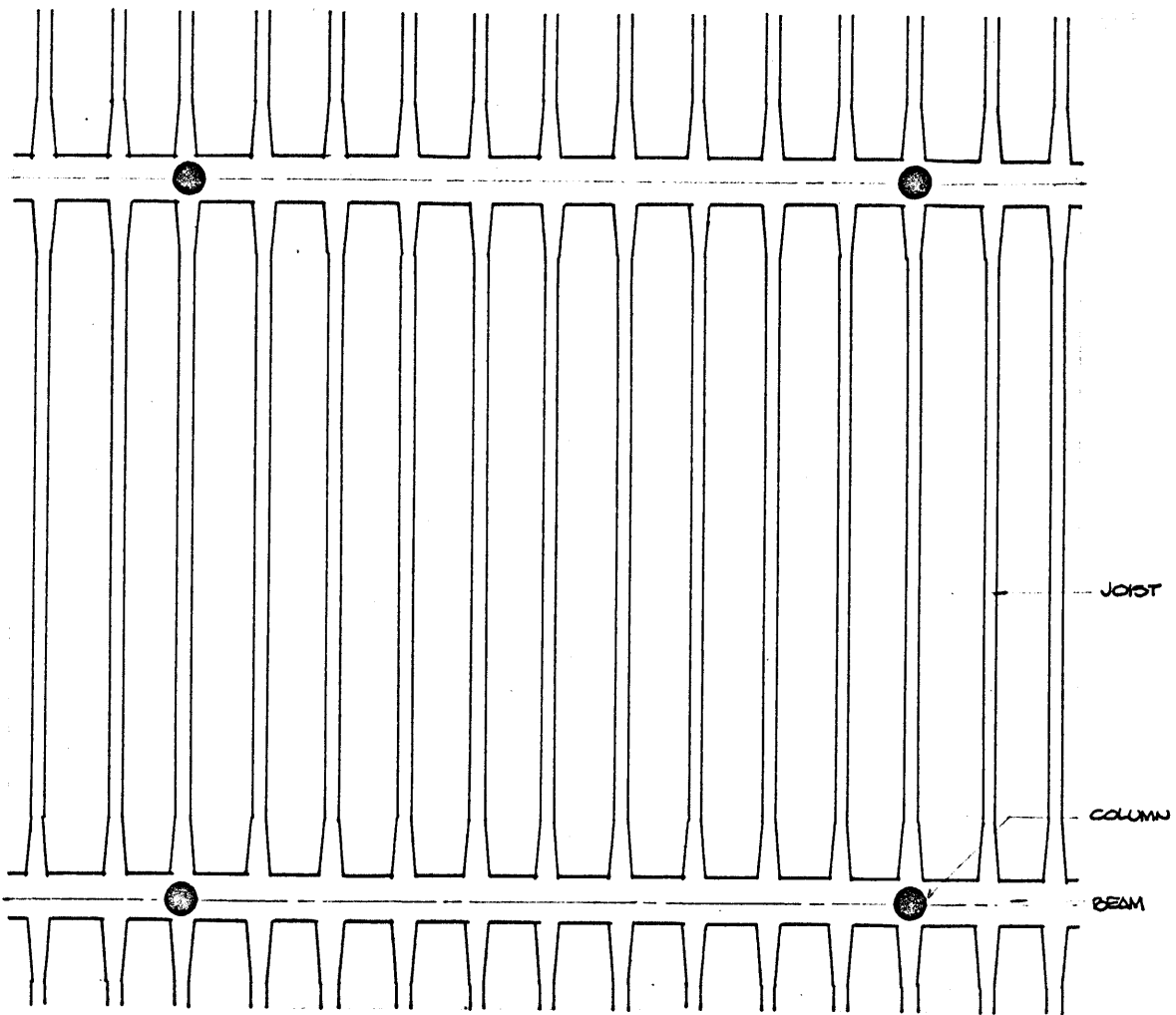

PLAN

FIGURE A-5

TWO-WAY RIBBED SLAB

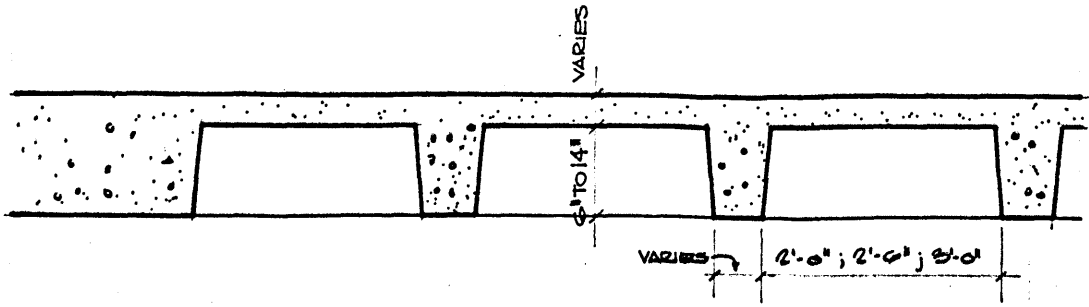

SECTION

SPAN TO 40'-0"

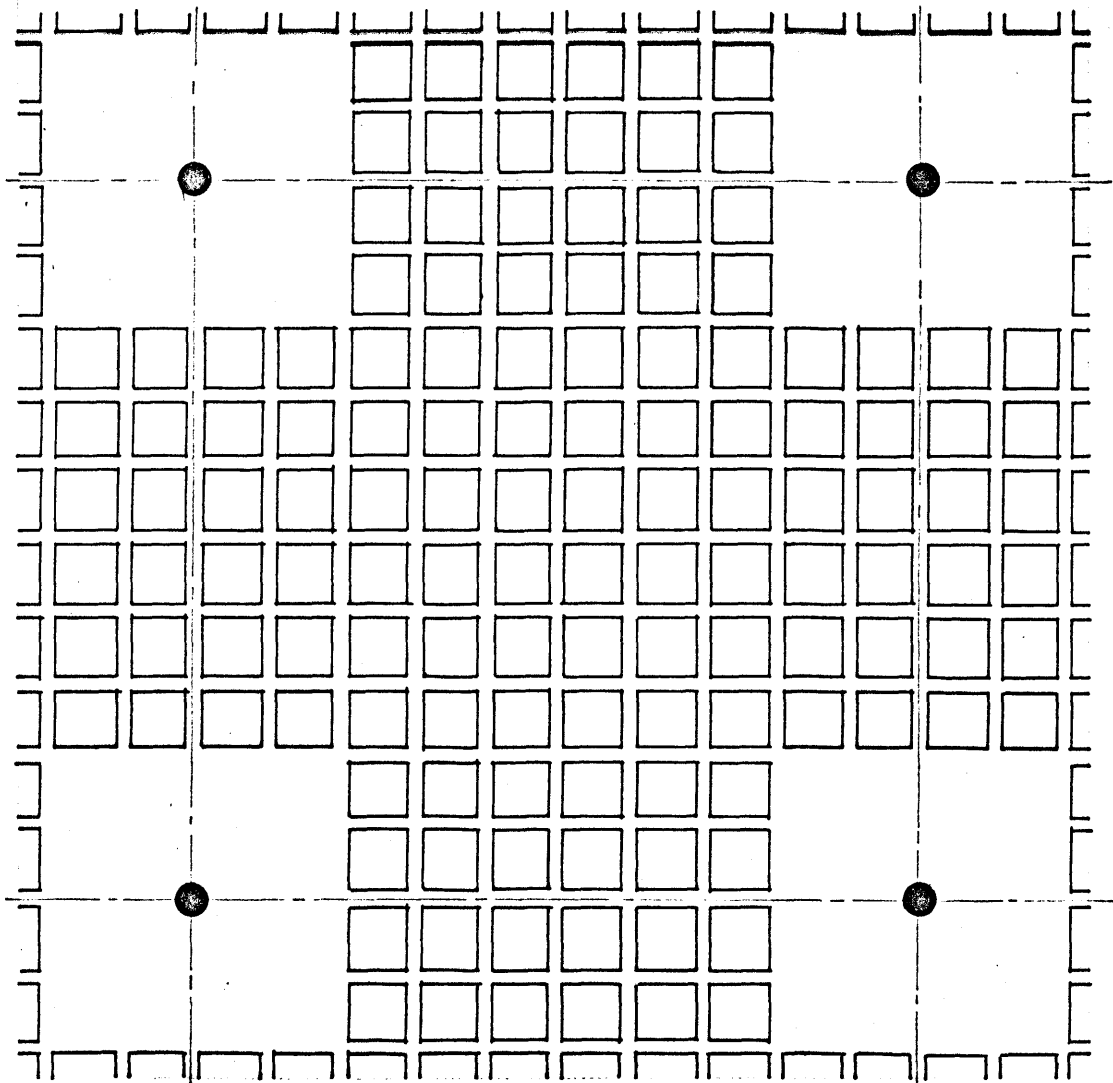

PLAN

FIGURE A-6

PROTOTYPE SCHOOL SYSTEMS

A. Prototype Schools in America

In America, most attempts to develop a prototype, modular school unit have used the principle of prefabrication.

This development has grown from the increasing interest in prefabricated housing. A majority of the developed systems have been conceived upon the basis of an ideal package unit. This unit is either pre-erected and shipped to the site or brought to the site in a compact form and unfolded.

Most of the prefabricated houses designed today are not of concrete construction and when prefabricated schools began to come into being they followed much the same path.

There are three systems of packaged schools, which are most successful in America today.

1. National Homes Corp. School Unit

This system produces a complete two classroom package unit. The basic unit is designed to be multiplied at will. The structure is of laminated wood. Non-combustible roof panels on metal tees span between beams.

2. Maximlite Schools

The Maximlite system incorporates masonry bearing walls with a flat roof. The exterior wall is constructed of glass blocks. Above the glass block is a clear glazed venting sash.

3. Structo Schools

A higher cost system, the Structo Schools naturally produces a school of somewhat higher quality. It is an assembly of steel members and porcelain enamel panels selected from the standard panels offered on the market.

These three systems have not been produced without objection and dissatisfaction. The National Homes School Unit has been accused of too much glare, lack of ventilation and generally poor construction. The Maximplite School, possibly the most criticized system, contains undersized classrooms, insufficient storage space and tack boards. The major objection to the Structo Unit is its high cost and inability to compete with the conventional schools being built.

These systems and most of the other systems developed in America are the direct result of an attempt to counter-balance the rising cost, consequently economy is the major concern.

Educational systems in America are also undergoing many changes. In 1959 Dr. Lloyd Trump published "Images of The Future", in which he describes his new approach to secondary schools. Dr. Trump's approach is based on increasing interest in installation of electronic and mechanical aids, a completely different organization of instructional staff, different student-faculty relationships and consequently new curriculums, class sizes and schedules.

Therefore the present school problem is a multi-fold one. There exists both a deep public concern over rising cost and developing educational concepts along with staggering student loads. In almost every case prefabrication has been selected to solve this problem.

B. Prototype Schools in England

Britain has also used prefabrication in the development of her prototype schools. Unlike the United States, economy was not the only motive.

The post war building industry could not handle the immense volume construction unless prefabrication, at least in part, were used. Prefabrication saved many costly hours both on the drawing boards and on the site.

Today England has a number of systems which are a result of this post war building boom.

1. A light steel frame with claddings of concrete slabs faced with stone drippings. The internal partitions are of gypsum plaster.
2. A steel frame with aluminum cladding and partitions of factory-made panels with gypsum plaster.
3. A cold rolled steel frame with cladding of precast concrete on the first floor and asbestos cement sheet on the upper stories. Internal partitions of gypsum plaster.
4. The inter-grid system. A prestressed concrete frame with precast cladding and internal partitions of gypsum plaster.

The "inter-grid" system is the only developed prototype modular system which uses reinforced concrete as the main structural component.

The Worthing Technical High School, built in 1950, was

the prototype for the "inter-grid" system. The system was pioneered by Messrs. Gilbert-Ash, and is believed to be the first prefabricated modular system ever designed in pre-stressed concrete. A one meter (3'-4") module was used. The components were factory made and post-tensioned on the site by the Freyssinet method. In this first prestressed school building, the stairwells were cast on the site, but since 1954 a completely prefabricated stair system has been worked out.

This system, in spite of its adaptability, contains only twenty-six (26) components; all of them are factory made units assembled and post tensioned on the job site.

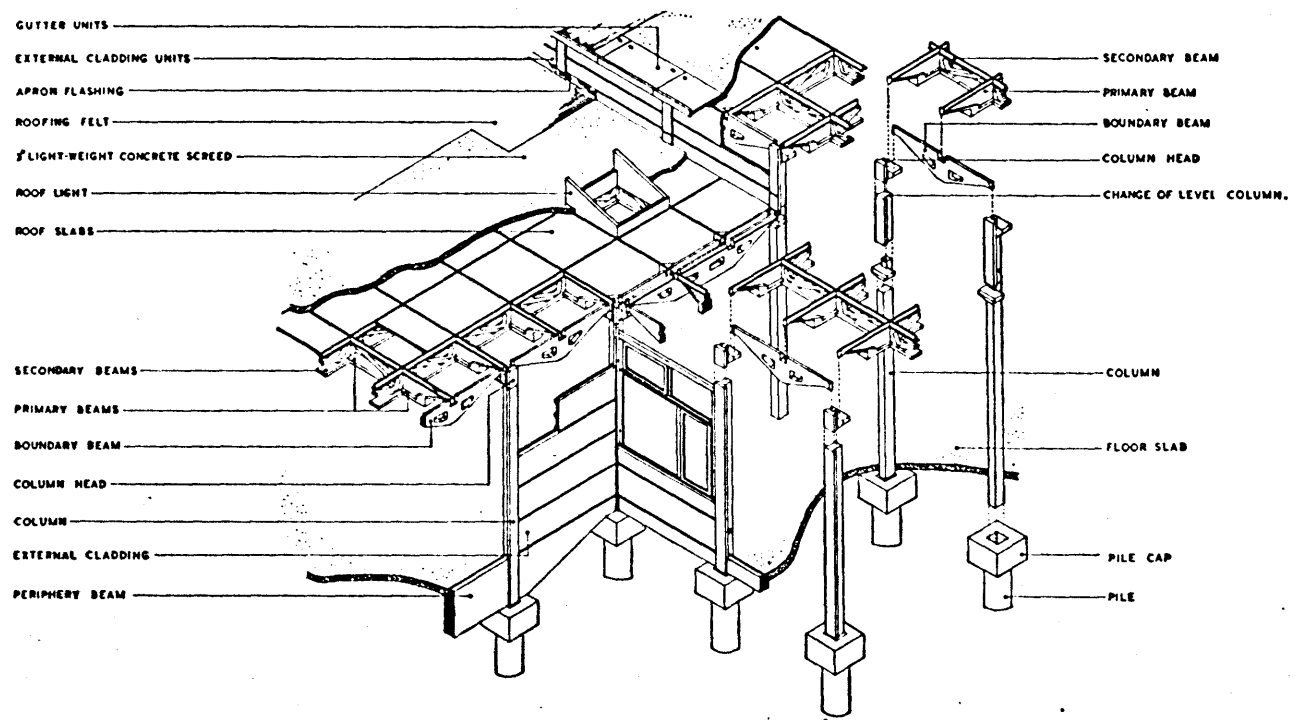
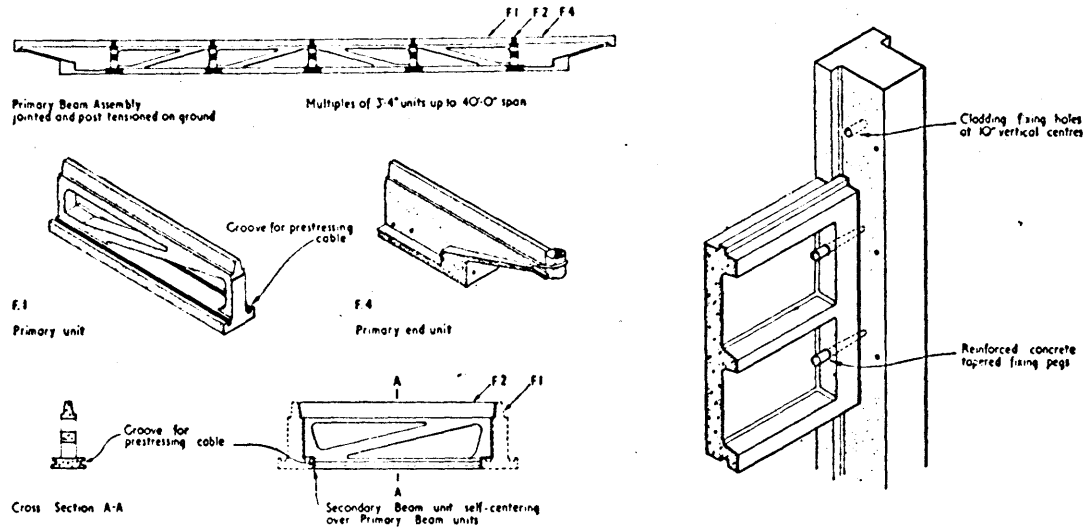

"INTER-GRID" SYSTEM

FIGURE A-7

EXAMPLES OF SCHOOL PLANS

A. A PROTOTYPE STRUCTURE

Ralph Knowles and Stanley Steinberg

Masters' Thesis M.I.T. 1959

This is one of the few studies of a prototype modular roof system. Basically, it is a reinforced concrete structure with ribs that are poured between a pre-moulded cement and fiber product.

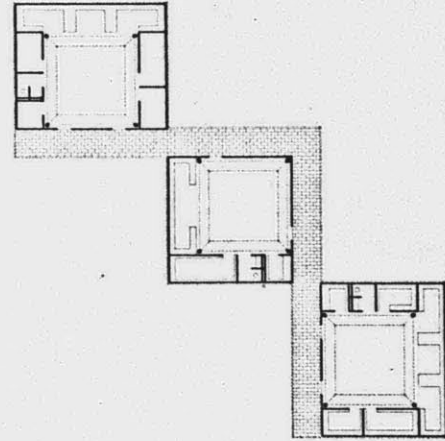
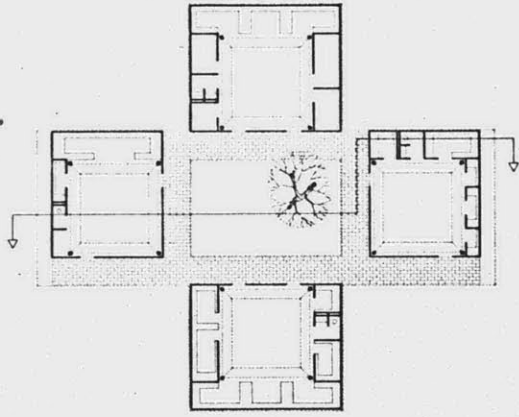
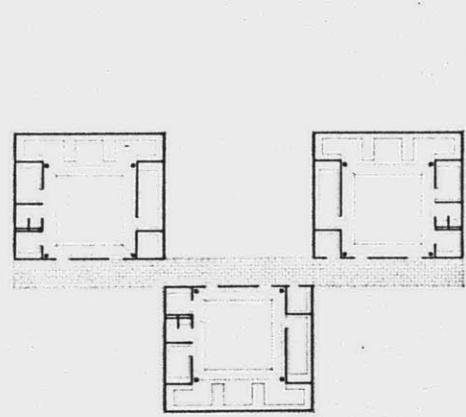
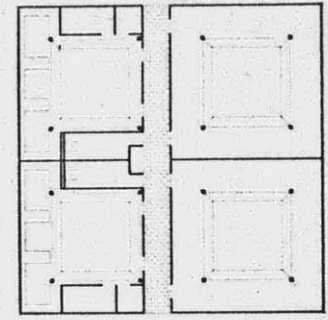
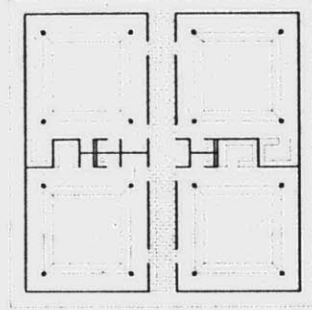
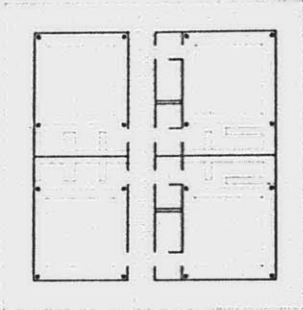

SIX POSSIBLE PLAN ARRANGEMENTS
SCALE 0.0625" = 1'-0"

FIGURE A-8

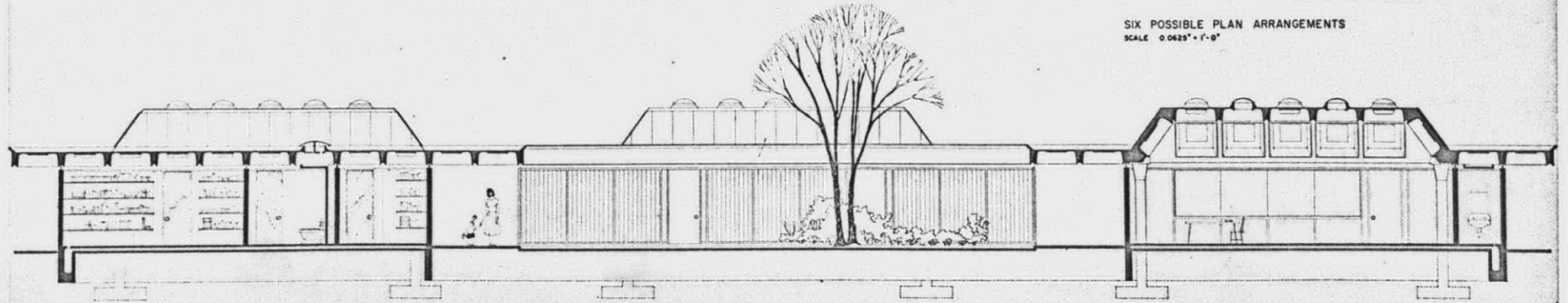

SECTION
SCALE 0.25" = 1'-0"

B. AN ELEMENTARY SCHOOL

H. Caminos and E.F. Catalano

First prize in the Porcelain Enamel Design Competition, 1956

Published in the Architectural Forum March 1956.

The organization of the school plan is based upon a modular classroom unit concept.

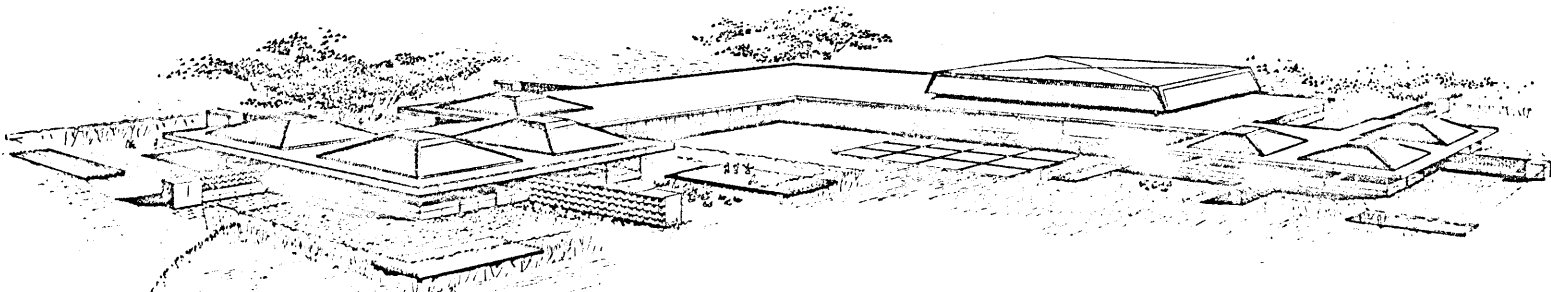

- 1 POT WASH.
- 2 CAN WASH.
- 3 TRASH
- 4 DRY STOR.
- 5 REF.
- 6 LOCKER
- 7 MEAT PREP.
- 8 COOKING
- 9 DESSERTS
- 10 VEG. PREP.
- 11 RECEIVING
- 12 STOR.
- 13 DISH WASH.
- 14 SERVING

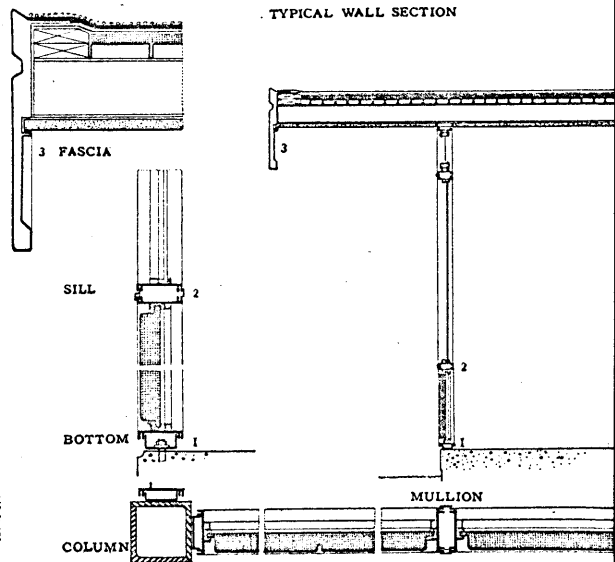
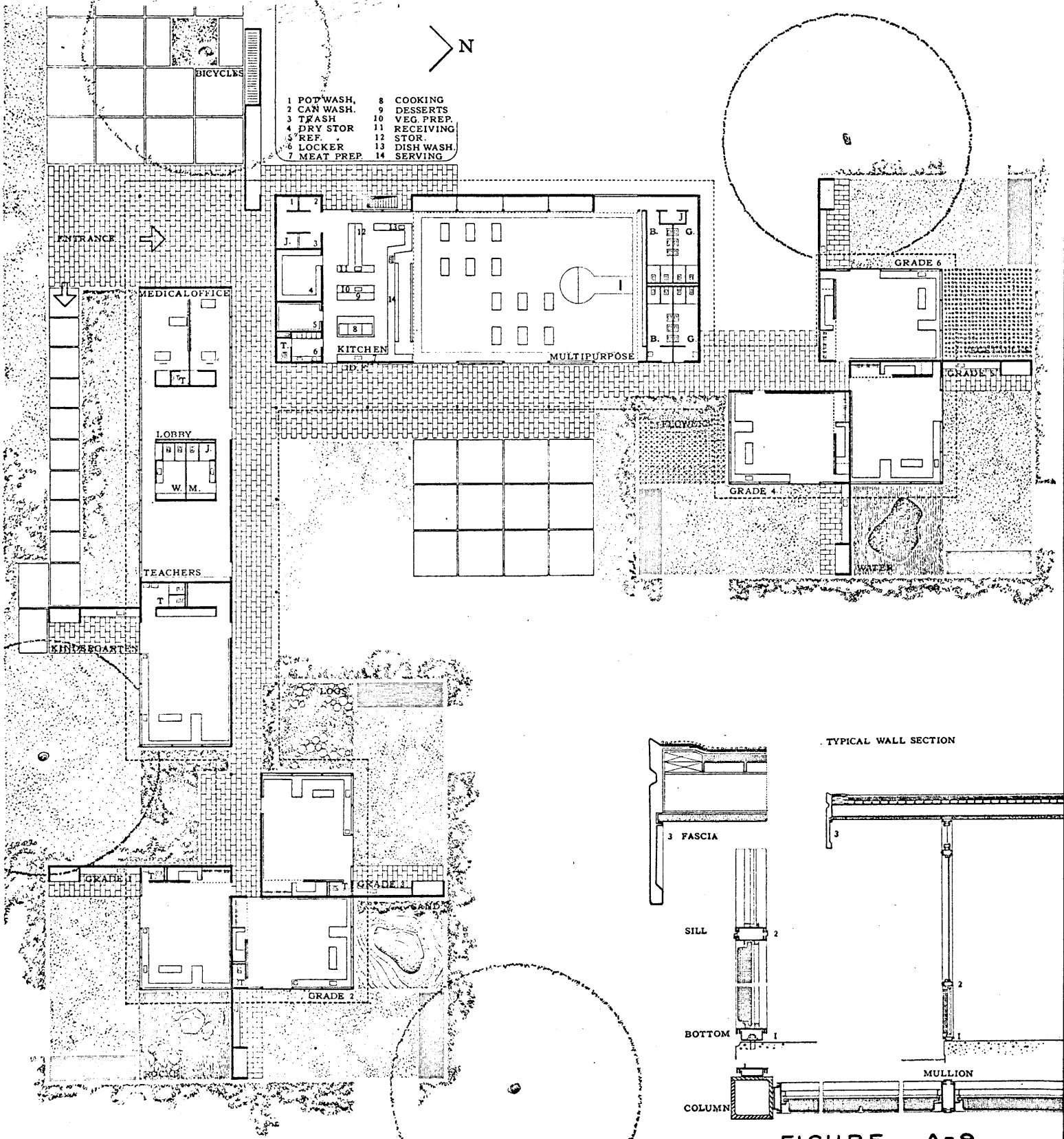

FIGURE A-9

C. WEST BRIDGEWATER, MASS. SCHOOL

The Architects' Collaborative, Cambridge, Mass.

Published by Alfred Roth The New School 1961.

The principle of cluster-units is used to develop a modular classroom complex.

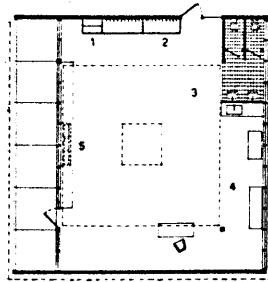

Proto-type classroom 1:300 /
 Prototyp-Klasseneinheit /
 Proto-type d'une unité de classe

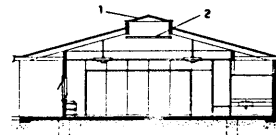

Cross-section 1:300 / Schnitt /
 Coupe

- 1 Plexiglas dome
- 2 Diffusing plastic panel

- 1 Teacher's coat
- 2 Students' coats
- 3 Main room
- 4 Work recess
- 5 Unit heater

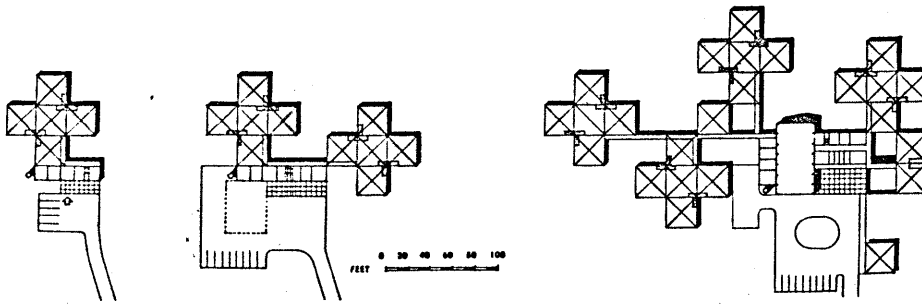

Growing school by adding new cluster-units 1:2000 / Wachsende Schule durch Anfügen neuer Klassengruppen / Ecole croissante, intégration successive de nouveaux groupes de classe.

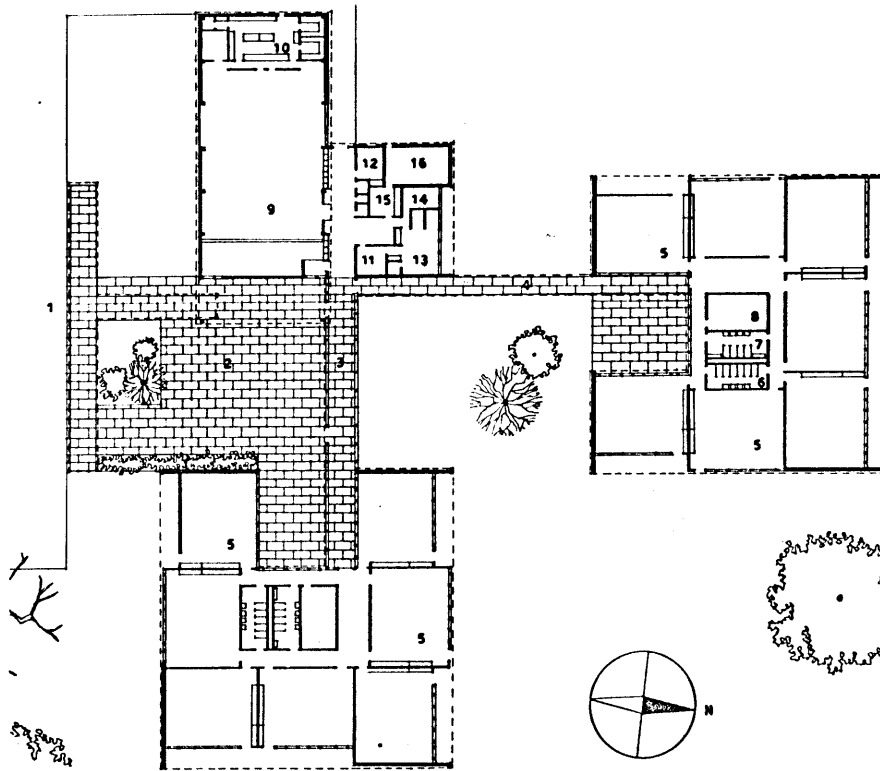

- 1 Entrance, covered passage
- 2 Courtyard
- 3 Glazed passage
- 4 Open passage
- 5 Classroom-unit
- 6 Girls' toilets
- 7 Boys' toilets
- 8 Heating and jan.
- 9 Multi-purpose room
- 10 Kitchen
- 11 Principal
- 12 Teachers' room
- 13 Medical cabinet
- 14 Dental cabinet
- 15 Storage
- 16 Heating and jan.

Lay-out of the West Bridgewater School 1:800 / Erdgeschoß der Gesamtanlage / Rez-de-chaussée

BIBLIOGRAPHY

- American Concrete Institute, Building Code Requirements for Reinforced Concrete. 1956.
- American Concrete Institute, Reinforced Concrete Design Handbook. Report by Committee 317. 1955.
- Billing, Kurt, Structural Precast Reinforced Concrete, The Cement and Concrete Association, London.
- Concrete Reinforcing Steel Institute, Design Handbook. Revised 1959
- Educational Facilities Laboratory, Design for Educational T.V. 1960.
- Ferguson, P.M., Reinforced Concrete Fundamentals. 1959.
- Godfrey, J.A. School Design and Construction
- McQuade, Walter, ed. Schoolhouse. 1958.
- National Research Council, National Building Code of Canada, 1953
- Roth, Alfred, The New School, 1961
- Trump, J. Lloyd, Images of the Future.

Periodical

- Porcelian Enamel Design Competition, The Architectural Forum, March 1956.
- Prefabs or Proprietary Plans for Schools, Architectural Record February 1956. pp 209-19.
- Moon, Parry, The New Approach to Room Lighting, Reprint from Illumination Engineering, April 1949.

Thesis

- Knowles, R. and Steinberg, , A Prototype Structure, Masters' Thesis, M.I.T. 1959
- Pratt Institute, Department of Architecture, School Research Thesis. Bulletin Number 1, 1954.