

# THE EQUIVALENT FORCE SYSTEM OF A MONOPOLE SOURCE IN A FLUID-FILLED OPEN BOREHOLE

by

Ari Ben-Menahem <sup>1</sup> and Sergio Kostek <sup>2</sup>

Earth Resources Laboratory  
Department of Earth, Atmospheric, and Planetary Sciences  
Massachusetts Institute of Technology  
Cambridge, MA 02139

## ABSTRACT

The elastodynamic body-wave field outside a fluid-filled open borehole due to a monopole source in the fluid, is reduced to the radiation-field due to a suitable equivalent force system (EFS) in the absence of the borehole, consisting of a monopole plus a vertical dipole. Theoretical seismograms of the EFS displacements in the solid are shown to be in excellent agreement with those obtained from the exact solution to the fluid-filled open borehole problem.

## INTRODUCTION

One of the major contributors to the complexity of boundary-value problems pertaining to theoretical modeling of exploration elastodynamics is the presence of both vertical and horizontal discontinuities. It has been known for a long time that it is sometimes possible to replace certain boundaries by a system of images, provided the extra stresses and displacements induced by these images could indeed mimic the discontinuities caused by the said boundaries (e.g., Ben-Menahem and Singh, 1981). In this vein, we show that part of the field created by a monopole source acting on the axis of a fluid-filled open borehole surrounded by a homogeneous and isotropic formation can be reconstructed with the aid of an equivalent force system (EFS) that mimics the geometrodynamical effects of the borehole. The advantages of the EFS are twofold. In the first place it simplifies the physical setup and brings many seemingly different problems into a common denominator in a sense that they are reduced to fields of known basic force

---

<sup>1</sup>On leave from the Department of Applied Mathematics, Weizmann Institute of Science, Rehovot 76100, Israel.

<sup>2</sup>On leave from Schlumberger-Doll Research, Old Quarry Road, Ridgefield, CT 06877-4108.

systems. Second, and this is not less important, much computer time is saved and numerical complexities are avoided.

The history of borehole elastodynamics goes back to Heelan (1953) who first obtained a closed-form solution for a finite line source in an empty borehole. Cheng and Toksöz (1981) calculated the acoustic field inside the borehole and Lee and Balch (1982) followed with the far-field radiation in the surrounding solid. We have used this later solution to test the validity of our model.

## THEORY

The geometry of the fluid-filled borehole and the various coordinate systems are shown in Figure 1. The source is a volume injection  $V_0$  on the axis with dimensionless time function  $g(t)$ . Lee and Balch (1982) have shown that the spherical components of the far-field displacement in the elastic solid are given by

$$u_R = \frac{\rho_f}{\rho} \frac{V_0}{4\pi R\alpha} A_p g'(t - \frac{R}{\alpha}), \quad (1)$$

$$u_\theta = \frac{\rho_f}{\rho} \frac{V_0}{4\pi R\beta} A_s g'(t - \frac{R}{\beta}), \quad (2)$$

$$u_\phi = 0, \quad (3)$$

where a prime (') indicates differentiation with respect to time,  $\alpha$  and  $\beta$  are respectively the compressional and shear velocities in the solid, and  $\rho$  and  $\rho_f$  are the densities in the solid and fluid respectively. The amplitude coefficients are given by

$$A_p = \frac{1}{\Gamma_p} \left( 1 - 2 \frac{\beta^2}{\alpha^2} \cos^2 \theta \right), \quad (4)$$

$$A_s = \frac{2}{\Gamma_s} \sin \theta \cos \theta, \quad (5)$$

where the quantities  $\Gamma_p$ ,  $\Gamma_s$ ,  $A$ ,  $\epsilon_p$ , and  $\epsilon_s$  are defined as

$$\Gamma_p = A \left( 1 - \epsilon_p^2 \cos^2 \theta \right), \quad (6)$$

$$\Gamma_s = A \left( 1 - \epsilon_s^2 \cos^2 \theta \right), \quad (7)$$

$$A = \frac{\rho_f}{\rho} + \frac{\beta^2}{\alpha_f^2}, \quad (8)$$

$$\epsilon_p^2 = \frac{\beta^2/\alpha^2}{\rho_f/\rho + \beta^2/\alpha_f^2} < 1, \quad (9)$$

$$\epsilon_s^2 = \frac{1}{\rho_f/\rho + \beta^2/\alpha_f^2} < 1. \quad (10)$$

$$(11)$$

Expanding  $\Gamma_p^{-1}(\cos^2 \theta)$  and  $\Gamma_s^{-1}(\cos^2 \theta)$  in power series of  $\epsilon_p^2 \cos^2 \theta < 1$  and  $\epsilon_s^2 \cos^2 \theta < 1$  respectively, we obtain

$$A_p = \frac{1}{A} + \frac{\epsilon_p^2 - 2\beta^2/\alpha^2}{A} \cos^2 \theta + \frac{\epsilon_p^2 (\epsilon_p^2 - 2\beta^2/\alpha^2)}{A} \cos^4 \theta + O(\epsilon_p^6 \cos^6 \theta), \quad (12)$$

$$A_s = \frac{2 \sin \theta \cos \theta}{A} \left[ 1 + \epsilon_s^2 \cos^2 \theta + \epsilon_s^4 \cos^4 \theta + O(\epsilon_s^6 \cos^6 \theta) \right]. \quad (13)$$

Substituting Eqs. (12) and (13) into Eqs. (1) and (2) respectively, and noting that  $\epsilon_p^2 < 2\beta^2/\alpha^2 < 1$  we obtain,  $O(\epsilon_p^2 \cos^2 \theta)$

$$u_R = \frac{1}{A} \frac{\rho_f}{\rho} \frac{V_0}{4\pi\alpha} \left[ \frac{1}{R} g' \left( t - \frac{R}{\alpha} \right) \right] \left[ 1 - \left( 2\frac{\beta^2}{\alpha^2} - \epsilon_p^2 \right) \cos^2 \theta \right], \quad (14)$$

$$u_\theta = \frac{2}{A} \frac{\rho_f}{\rho} \frac{V_0}{4\pi\beta} \left[ \frac{1}{R} g' \left( t - \frac{R}{\beta} \right) \right] \sin \theta \cos \theta. \quad (15)$$

Consulting our catalog of source fields in the Appendix, we find by inspection that the displacements given in (14) and (15) are induced by the following sources:

(a) A monopole source with moment  $M_0 = V_0 \rho_f \alpha^2 / (\rho_f / \rho + \beta^2 / \alpha_f^2)$ ,

(b) A dipole in the  $z$ -direction with moment  $M = -(2\beta^2 / \alpha^2 - \epsilon_p^2) M_0$ .

This model can be successively improved by adding quadrupole terms ( $\propto \cos^4 \theta$ ) and higher order multipoles. It is also worthwhile mentioning that the sensitivity pattern of a hydrophone (pressure sensing device) in a fluid-filled open borehole is also given by the ESF, due to reciprocity.

## NUMERICAL RESULTS

To illustrate the simple theoretical results obtained, we have computed the elastodynamic field due to a volume injection source on the axis of a fluid-filled open borehole and compared it to the field caused by the system of forces described in (a) and (b) above. Figure 2 shows the setup in the borehole case as well as the fluid and solid elastic parameters. The dimensionless source time-function is chosen to be the second derivative of the Blackman-Harris window function (Harris, 1978). The duration of the pulse is  $1.55/f_c$ , where  $f_c$  denotes the center frequency of the pulse taken here as 1 kHz. The displacements in the solid in the borehole case are calculated assuming a volume displacement source  $v(t) = V_0 g(t)$ . Its Fourier transform is denoted as  $V(\omega)$ . The displacement potential corresponding to such a source is given by

$$\phi_{in}^f(r, \varphi, z, t) = \frac{1}{2\pi} \int_{-\infty}^{+\infty} -V(\omega) \frac{e^{-i\frac{\omega}{\alpha_f} R}}{R} e^{i\omega t} d\omega, \quad (16)$$

where  $R = (r^2 + z^2)^{1/2}$ . In the borehole fluid, the displacement potential can be cast as the sum of an incident and a reflected field (Kurkjian, 1986)

$$\begin{aligned} \phi^f(r, \varphi, z, t) = & \frac{i}{4\pi} \int_{-\infty}^{+\infty} d\omega V(\omega) e^{i\omega t} \\ & \int_{-\infty}^{+\infty} dk_z \left[ H_0^{(2)}(k_r^f r) + A(k_z, \omega) J_0(k_r^f r) \right] e^{-ik_z z}, \end{aligned} \quad (17)$$

where the radial wave-number in the fluid is given by  $k_r^f = (\omega^2/\alpha_f^2 - k_z^2)^{1/2}$ . In the solid, the displacement field can be expressed in terms of the compressional and shear potentials as

$$\mathbf{u}(r, t) = \nabla\phi(r, t) + \nabla \times [\psi(r, t)\mathbf{e}_\varphi]. \quad (18)$$

These displacement potentials can be cast into a form similar to the one used for the fluid potential

$$\phi(r, \varphi, z, t) = \frac{i}{4\pi} \int_{-\infty}^{+\infty} d\omega V(\omega) e^{i\omega t} \int_{-\infty}^{+\infty} dk_z B(k_z, \omega) H_0^{(2)}(k_r^\alpha r) e^{-ik_z z}, \quad (19)$$

$$\psi(r, \varphi, z, t) = \frac{i}{4\pi} \int_{-\infty}^{+\infty} d\omega V(\omega) e^{i\omega t} \int_{-\infty}^{+\infty} dk_z C(k_z, \omega) H_1^{(2)}(k_r^\beta r) e^{-ik_z z} \quad (20)$$

where  $k_r^\alpha = (\omega^2/\alpha^2 - k_z^2)^{1/2}$  and  $k_r^\beta = (\omega^2/\beta^2 - k_z^2)^{1/2}$ . The unknown coefficient functions  $A(k_z, \omega)$ ,  $B(k_z, \omega)$  and  $C(k_z, \omega)$  are found by imposing the continuity of the normal stress and displacement, and the vanishing of the shear stress at the fluid-solid interface ( $r = a$ ). Once these coefficients are found, the displacements in the solid can be computed from Eq. (18). The integrals in Eqs. (19) and (20) are numerically evaluated following the same procedure as in Tsang and Rader (1979). Figure 3 shows the radial and axial components of the particle displacements at the receiver positions shown in Figure 2 for both the monopole source on the axis of the fluid-filled borehole (solid curves), and the EFS in an infinite homogeneous elastic medium (dotted curves). The first arrivals in these waveforms correspond to the P-wave followed by the S-wave. The EFS displacement waveforms were computed with the expressions given in the Appendix. Notice the excellent agreement between the waveforms.

## CONCLUSION

Our results confirm the notion that boundaries in elastodynamical configurations can be replaced by force systems which may reproduce with sufficient accuracy, part or parts of the total field. Thus, our EFS excludes *tube waves*. To obtain these, one must *add* a field of a supershear moving source for the case where the tube wave velocity is greater than the shear wave velocity in the solid (de Bruin and Huizer, 1989; Ben-Menahem, 1990). A further extension of our results to the case where the borehole intersects a horizontal bed boundary, separating two elastic solid media, is now underway.

## ACKNOWLEDGMENTS

We would like to thank Prof. M.N. Toksöz for an enlightening discussion. This research was supported by the Defense Advanced Research Project Agency contract #F19628-89-K-0020.

## REFERENCES

- Ben-Menahem, A., and S.J. Singh, *Seismic Waves and Sources*, Springer-Verlag, 1981.
- Ben-Menahem, A., Signal enhancement with Mach-Čerenkov waves, *J. Acoust. Soc. Am.*, submitted, 1990.
- Cheng, C.H., and M.N. Toksöz, Elastic wave propagation in a fluid-filled borehole and synthetic acoustic logs, *Geophysics*, 46, 1042-1043, 1981.

- de Bruin, J.A., and W. Huizer, Radiation from waves on boreholes, *Scientific Drilling*, 1, 3-10, 1989.
- Harris, F.J., On the use of windows for harmonic analysis with the discrete Fourier transform, *Proc. IEEE*, 66, 51-83, 1978.
- Heelan, P.A., Radiation from a cylindrical source of finite length, *Geophysics*, 18, 685-696, 1953.
- Kurkjian, A.L., and S.K. Chang, Acoustic multipole sources in fluid-filled boreholes, *Geophysics*, 51, 148-163, 1986.
- Lee, M.W., and A.H. Balch, Theoretical seismic wave radiation from a fluid-filled borehole, *Geophysics*, 47, 1308-1314, 1982.
- Tsang, L., and D. Rader, Numerical evaluation of the transient acoustic waveform due to a point source in a fluid-filled borehole, *Geophysics*, 44, 1706-1720, 1979.

## APPENDIX A: DISPLACEMENT FIELDS OF SIMPLE SOURCES

In an unbounded isotropic-homogeneous elastic medium, the far-field spectral Green's-tensor  $\mathbf{G}$  (Ben-Menahem and Singh, 1981) has the explicit form

$$4\pi\mu\mathbf{G}(\mathbf{r}|\mathbf{r}_0;\omega) = \frac{\beta^2}{\alpha^2} \frac{e^{-ik_\alpha R}}{R} \mathbf{e}_R \mathbf{e}_R + \frac{e^{-ik_\beta R}}{R} (\mathbf{e}_\theta \mathbf{e}_\theta + \mathbf{e}_\varphi \mathbf{e}_\varphi) + O(k_\beta^{-2} R^{-2}), \quad (\text{A.1})$$

where  $k_\alpha = \omega/\alpha$ ,  $k_\beta = \omega/\beta$  are the respective P and S wave-numbers,  $\omega$  is the angular frequency,  $\mu$  is the solid's rigidity and  $(\mathbf{e}_R, \mathbf{e}_\theta, \mathbf{e}_\varphi)$  are field unit vectors in a spherical coordinate system (Figure 1).

In terms of the above tensor, the elastodynamic far-field displacements of some sources are:

$$\text{Single-force:} \quad \mathbf{u} = F_0(\omega) \mathbf{G} \cdot \mathbf{e}, \quad (\text{A.2})$$

$$\text{Dipole in } \mathbf{e}\text{-direction with moment } M_0(\omega)\mathbf{a}: \quad \mathbf{u} = -M_0(\omega) \mathbf{e} \mathbf{e} : \nabla \mathbf{G}, \quad (\text{A.3})$$

$$\text{Explosion:} \quad \mathbf{u} = -M_0(\omega) \nabla \cdot \mathbf{G}, \quad (\text{A.4})$$

where the force acts along the  $\mathbf{e}$ -direction, its spectrum is denoted by  $F_0(\omega)$ , and differentiation is carried out in field-coordinates ( $\nabla = -\nabla_0$ ).

We shall need the gradient of  $\mathbf{G}$ , obtained by a straightforward application of the operator  $\nabla$  to both sides of (A.1)

$$-4\pi\mu\nabla\mathbf{G} = ik_\alpha \frac{\beta^2}{\alpha^2} \frac{e^{-ik_\alpha R}}{R} \mathbf{e}_r \mathbf{e}_R \mathbf{e}_R + ik_\beta \frac{e^{-ik_\beta R}}{R} (\mathbf{e}_R \mathbf{e}_\theta \mathbf{e}_\theta + \mathbf{e}_R \mathbf{e}_\varphi \mathbf{e}_\varphi) + O(k_\beta^{-2} R^{-2}) \quad (\text{A.5})$$

Using the matrix-relation

$$\begin{bmatrix} \mathbf{e}_x \\ \mathbf{e}_y \\ \mathbf{e}_z \end{bmatrix} = \begin{bmatrix} \sin\theta \cos\varphi & \cos\theta \cos\varphi & -\sin\varphi \\ \sin\theta \sin\varphi & \cos\theta \sin\varphi & \cos\varphi \\ \cos\theta & -\sin\theta & 0 \end{bmatrix} \begin{bmatrix} \mathbf{e}_R \\ \mathbf{e}_\theta \\ \mathbf{e}_\varphi \end{bmatrix}, \quad (\text{A.6})$$

we obtain from the combined use of (A.1)–(A.6) the following far-field displacements in time-domain, with  $f(t) = \frac{1}{2\pi} \int_{-\infty}^{+\infty} F_0(\omega)e^{i\omega t}d\omega$ ,  $m(t) = \frac{1}{2\pi} \int_{-\infty}^{+\infty} M_0(\omega)e^{i\omega t}d\omega$ , and  $\partial/\partial R = -c^{-1}\partial/\partial t$ :

I. Single-force in the z-direction ( $\mathbf{e} = \mathbf{e}_z$ ):

$$u_R = \frac{1}{4\pi(\lambda + 2\mu)} \left[ \frac{1}{R} f\left(t - \frac{R}{\alpha}\right) \right] \cos \theta, \quad (\text{A.7})$$

$$u_\theta = -\frac{1}{4\pi\mu} \left[ \frac{1}{R} f\left(t - \frac{R}{\beta}\right) \right] \sin \theta, \quad (\text{A.8})$$

$$u_\varphi = 0. \quad (\text{A.9})$$

II. Single-force in the x-direction ( $\mathbf{e} = \mathbf{e}_x$ ):

$$u_R = \frac{1}{4\pi(\lambda + 2\mu)} \left[ \frac{1}{R} f\left(t - \frac{R}{\alpha}\right) \right] \sin \theta \cos \varphi, \quad (\text{A.10})$$

$$u_\theta = \frac{1}{4\pi\mu} \left[ \frac{1}{R} f\left(t - \frac{R}{\beta}\right) \right] \cos \theta \cos \varphi, \quad (\text{A.11})$$

$$u_\varphi = -\frac{1}{4\pi\mu} \left[ \frac{1}{R} f\left(t - \frac{R}{\beta}\right) \right] \sin \varphi. \quad (\text{A.12})$$

III. Explosion with moment  $m(t)$ :

$$u_R = \frac{1}{4\pi\alpha(\lambda + 2\mu)} \left[ \frac{1}{R} m'\left(t - \frac{R}{\alpha}\right) \right], \quad (\text{A.13})$$

$$u_\theta = 0, \quad (\text{A.14})$$

$$u_\varphi = 0, \quad (\text{A.15})$$

where a prime (') indicates differentiation with respect to time.

IV. Dipole in the z-direction ( $\mathbf{ee} = \mathbf{e}_z\mathbf{e}_z$ ), with moment  $m(t)$ :



$$u_R = \frac{1}{4\pi\alpha(\lambda + 2\mu)} \left[ \frac{1}{R} m'(t - \frac{R}{\alpha}) \right] \cos^2 \theta, \quad (\text{A.16})$$

$$u_\theta = -\frac{1}{4\pi\mu\beta} \left[ \frac{1}{R} m'(t - \frac{R}{\beta}) \right] \sin \theta \cos \theta, \quad (\text{A.17})$$

$$u_\varphi = 0. \quad (\text{A.18})$$

V. Dipole in the  $x$ -direction ( $\mathbf{ee} = \mathbf{e}_x \mathbf{e}_x$ ), with moment  $m(t)$ :

$$u_R = \frac{1}{4\pi\alpha(\lambda + 2\mu)} \left[ \frac{1}{R} m'(t - \frac{R}{\alpha}) \right] \sin^2 \theta \cos^2 \varphi, \quad (\text{A.19})$$

$$u_\theta = \frac{1}{4\pi\mu\beta} \left[ \frac{1}{R} m'(t - \frac{R}{\beta}) \right] \sin \theta \cos \theta \cos^2 \varphi, \quad (\text{A.20})$$

$$u_\varphi = -\frac{1}{4\pi\mu\beta} \left[ \frac{1}{R} m'(t - \frac{R}{\beta}) \right] \sin \theta \sin \varphi \cos \varphi. \quad (\text{A.21})$$

VI. Dipole in the  $y$ -direction ( $\mathbf{ee} = \mathbf{e}_y \mathbf{e}_y$ ), with moment  $m(t)$ :

$$u_R = \frac{1}{4\pi\alpha(\lambda + 2\mu)} \left[ \frac{1}{R} m'(t - \frac{R}{\alpha}) \right] \sin^2 \theta \sin^2 \varphi, \quad (\text{A.22})$$

$$u_\theta = \frac{1}{4\pi\mu\beta} \left[ \frac{1}{R} m'(t - \frac{R}{\beta}) \right] \sin \theta \cos \theta \sin^2 \varphi, \quad (\text{A.23})$$

$$u_\varphi = \frac{1}{4\pi\mu\beta} \left[ \frac{1}{R} m'(t - \frac{R}{\beta}) \right] \sin \theta \sin \varphi \cos \varphi. \quad (\text{A.24})$$

VII. Dipole in the  $x$ -direction plus dipole in  $y$ -direction with same moment  $m(t)$ :

$$u_R = \frac{1}{4\pi\alpha(\lambda + 2\mu)} \left[ \frac{1}{R} m'(t - \frac{R}{\alpha}) \right] \sin^2 \theta, \quad (\text{A.25})$$

$$u_\theta = \frac{1}{4\pi\mu\beta} \left[ \frac{1}{R} m'(t - \frac{R}{\beta}) \right] \sin \theta \cos \theta, \quad (\text{A.26})$$

$$u_\varphi = 0. \quad (\text{A.27})$$

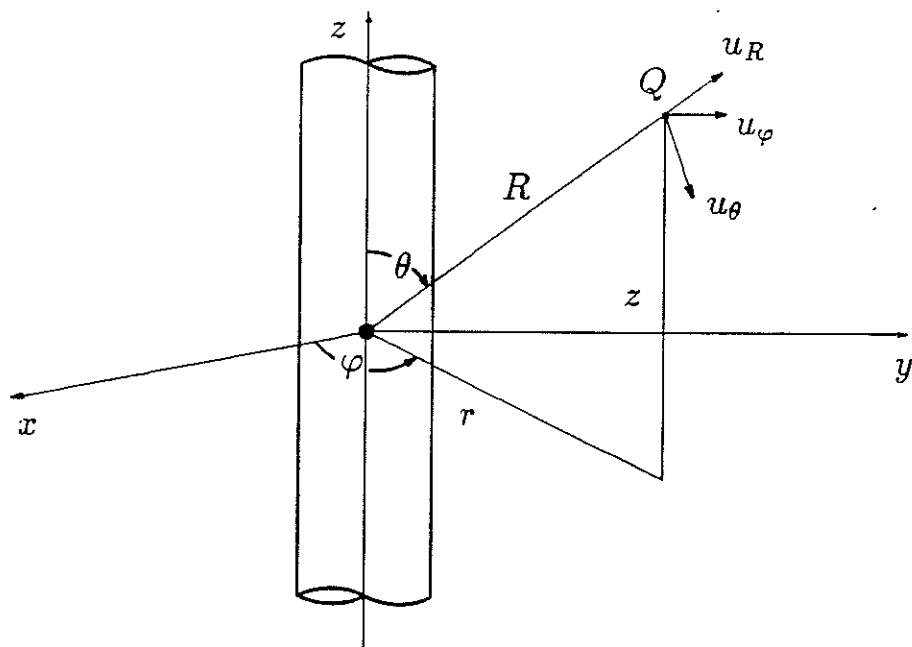

Figure 1: Geometry of the primary source on the axis of the borehole ( $z$ ). Sensor is at  $Q(x, y, z)$  in cartesian coordinates,  $(R, \theta, \varphi)$  in spherical coordinates and  $(r, \varphi, z)$  in cylindrical coordinates. Displacement vector at  $Q$  is  $(u_R, u_\theta, u_\varphi)$ . The borehole radius is  $a$  and  $\rho_f$  and  $\alpha_f$  are respectively the density and compressional velocity of the fluid. The elastic parameters of the solid medium are  $(\alpha, \beta, \rho)$ , denoting P-wave velocity, S-wave velocity and density respectively.

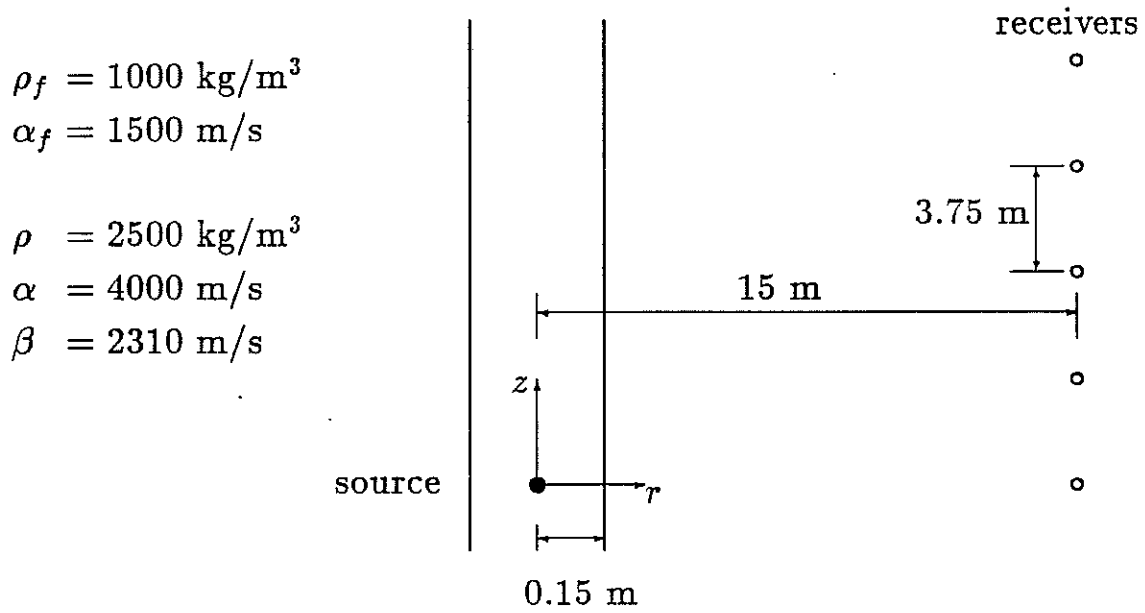

Figure 2: Source and receivers arrangement for the numerical example. Receivers measure radial ( $u_r$ ) and vertical ( $u_z$ ) particle displacements. Also shown are the fluid and solid elastic parameters.

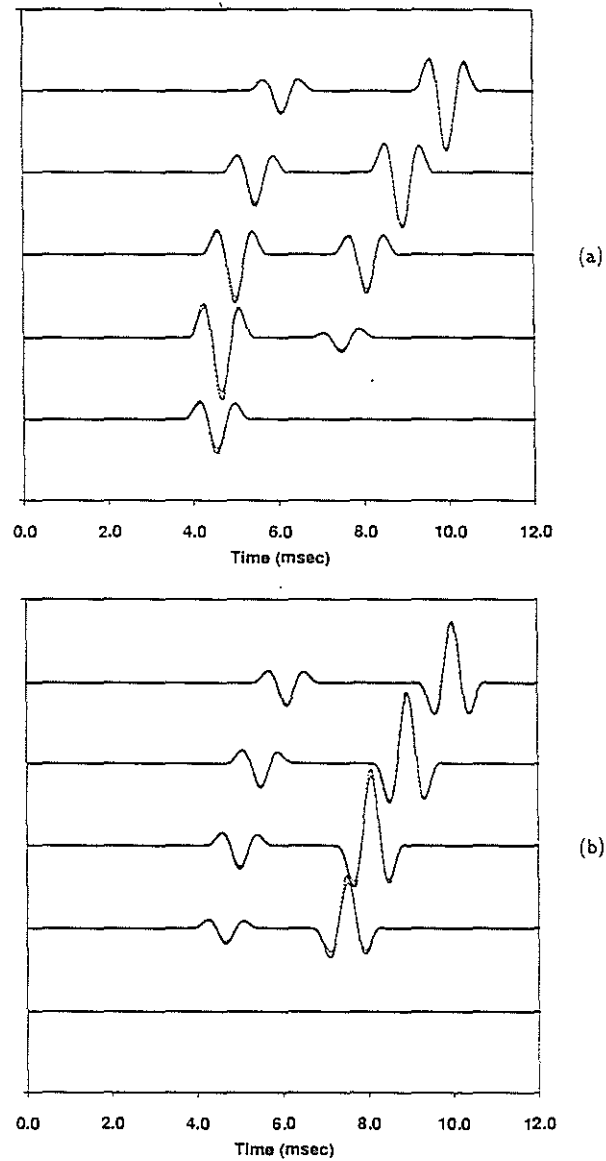

Figure 3: Particle displacement waveforms in the solid. The solid curves are for the case of a monopole source on the axis of the fluid-filled borehole, and the dots correspond to the EFS in an infinite homogeneous elastic medium. (a) Radial component. (b) Axial component.