

BESSIE AND THE MANIGAULTS:
RECONSTRUCTING A PLANTATION BOAT AND ANTEBELLUM BOATING CULTURE
IN SOUTH CAROLINA RICE COUNTRY

by

Patrick Forrest Herman

April, 2017

Director: Dr. David Stewart

Major Department: History and Maritime Studies

Bessie is a plantation boat originally constructed and owned by the Manigault family of South Carolina. It was built and used on a mid-nineteenth century rice plantation, and is now a permanent exhibit in the Charleston Museum, in Charleston, South Carolina. The vessel is characterized by the elegant boat-shape of its dugout cypress hull, and the use of extensive framing in its interior. Although ubiquitous in the region and period, this is one of the last remaining examples of a vessel type that has not been extensively studied, and has no clear economic purpose on the plantation. This thesis argues that the vessel can best be understood in a cultural context, and is representative of class values and social status in the planter culture of the Old South. An archaeological reconstruction of *Bessie* is used to better understand the vessel as well as boat building traditions that went into its design. The methodology of digital recording and modeling is evaluated to show clear promise for the field of ship reconstruction within appropriate practical and theoretical parameters. The reconstruction reveals *Bessie* to be a capable vessel best used for recreation, transportation, and demonstration of wealth and status.

BESSIE AND THE MANIGAULTS:
RECONSTRUCTING A PLANTATION BOAT AND ANTEBELLUM BOATING CULTURE
IN SOUTH CAROLINA RICE COUNTRY

A Thesis

Presented to the Faculty of the Department of History
East Carolina University

In Partial Fulfillment of the Requirements for the Degree
Master of Arts in Maritime Studies

by

Patrick Forrest Herman

April, 2017

© 2017, Patrick Forrest Herman

BESSIE AND THE MANIGAULTS:
RECONSTRUCTING A PLANTATION BOAT AND ANTEBELLUM BOATING CULTURE
IN SOUTH CAROLINA RICE COUNTRY

by

Patrick Forrest Herman

APPROVED BY:

DIRECTOR OF THESIS:

David J. Stewart, PhD

COMMITTEE MEMBER:

Lynn B. Harris, PhD

COMMITTEE MEMBER:

David C. Dennard, PhD

COMMITTEE MEMBER:

Frederick M. Hocker, PhD

CHAIR OF THE
DEPARTMENT OF HISTORY:

Christopher A. Oakley, PhD

DEAN OF THE
GRADUATE SCHOOL:

Paul J. Gemperline, PhD

TABLE OF CONTENTS

LIST OF TABLES	vi
LIST OF FIGURES	vii
CHAPTER 1: INTRODUCTION.....	1
<i>Bessie</i>	1
Research Questions.....	4
Outline.....	6
Hypothesis.....	7
Literature Review.....	8
Theoretical Framework.....	11
Historical Methodology	23
Archaeological Methodology.....	26
CHAPTER 2: A HISTORY	30
Introduction.....	30
The Manigaults, White Oak Plantation, and <i>Bessie</i>	35
Boats and Slaves	40
Economic and Utilitarian Use of Plantation Boats	45
Plantation Recreation	50
Historical Conclusions	54
CHAPTER 3: RECONSTRUCTION METHODOLOGY	56
Introduction.....	56
Total Station Recording	57
Modeling in Rhinoceros.....	62

Modeling a Knee.....	71
Lessons of Reconstruction	79
CHAPTER 4: THE MODEL	84
Introduction.....	84
Choices in Modeling <i>Bessie</i>	84
The Log of Digital <i>Bessie</i>	89
Repairs from the Life of <i>Bessie</i>	94
Interpretations of <i>Bessie</i> 's Build.....	99
<i>Bessie</i> in Orca 3D.....	103
CHAPTER 5: INTERPRETATIONS, CONCLUSIONS, AND FUTURE WORK	114
Introduction.....	114
Where does <i>Bessie</i> 's Design Come From?	114
Interpreting Digital <i>Bessie</i> in an Historical Context.....	121
Conclusions and Future Work	126
REFERENCES	130
APPENDIX A: ADDITIONAL PHOTOS AND DRAWINGS OF <i>BESSIE</i>	140
APPENDIX B: WHITE OAK PLANTATION MAPS AND PHOTO	157
APPENDIX C: MODELING LOG	161

LIST OF TABLES

1. <i>Bessie</i> Performance and Stability with 12% Cypress Moisture Content	109
2. <i>Bessie</i> Performance and Stability with 30% Cypress Moisture Content	109
3. <i>Bessie</i> Performance and Stability with 146% Cypress Moisture Content	110

LIST OF FIGURES

1. <i>Bessie</i> at the Charleston Museum	3
2. Point Cloud for Thwart 1 Knees	71
3. Annotated Drawings with Point Locations for Thwart 1 Knees.....	72
4. Rough Wireframe Construction for Thwart 1 Knees.....	73
5. Completed Rough Wireframe for Port Thwart 1 Knee.....	74
6. Port Thwart 1 Knee with Simple Curves (red) and Controlled Curves (black).....	75
7. Port Thwart 1 Knee with Basic Surfaces Applied to the Wireframe	76
8. Final Solid Shape for Port Thwart 1 Knee (blue)	78
9. Rendering of Complete <i>Bessie</i> Model	87
10. Final Shape of Remaining Log in <i>Bessie</i>	92
11. Bow Shape with Flattened Port Quarter	93
12. Void Filling Block in the Upper Bow behind the Stem.....	95
13. Stern Repair Area with Cypress Repair Block	96
14. Repair and Filler Blocks Fitted into the Log Hull	98
15. Internal Structural Elements of <i>Bessie</i>	100
16. Metal Fastener Distribution throughout <i>Bessie</i>	101
17. Lines Drawing of <i>Bessie</i> Generated in Orca 3D.....	113
18. Stern View of <i>Bessie</i> Interior in Charleston Museum Courtyard	140
19. <i>Bessie</i> in the Courtyard of the Charleston Museum.....	141
20. <i>Bessie</i> View from Stern Quarter	141
21. <i>Bessie</i> Starboard Bow Profile	142
22. <i>Bessie</i> Starboard Bow Profile Detail Drawing.....	142

23. Close Up of Starboard Bow Construction	143
24. <i>Bessie</i> Port Bow Profile	143
25. <i>Bessie</i> Hull Bottom and Keel from Starboard Side facing Aft	144
26. <i>Bessie</i> Starboard Hull facing forward	144
27. <i>Bessie</i> Starboard Stern Profile	145
28. <i>Bessie</i> Port Stern Profile	145
29. <i>Bessie</i> Transom with Various Repairs	146
30. <i>Bessie</i> Forward Interior Area	146
31. <i>Bessie</i> Interior facing Aft from Bow	147
32. <i>Bessie</i> Interior facing Forward from Stern Deck	147
33. Close Up of Interior Bow and Breasthook from above the Mast Partner	148
34. Close Up of Interior Bow and Repairs from below the Mast Partner	148
35. Forward Mast Partner and Supporting Structures from Port Side	149
36. Forward Mast Steps and Floor Timbers from Starboard Side	149
37. Aft Mast Steps and Partner from Starboard Side	150
38. Centerboard Trunk and Surrounding Structure looking forward from Port Side	150
39. Thwart 1 Knees and Surrounding Structures	151
40. Thwart 1 and Surrounding Structures from Above	151
41. Thwart 2 and Surrounding Structures from Above	152
42. Thwart 3 and Surrounding Structures from Above	152
43. Thwart 4 and Surrounding Structures from Above	153
44. Thwart 5 and Surrounding Structures from Above	153
45. Thwart 6 and Surrounding Structures from Above	154

46. Thwart 7 and Surrounding Structures from Above.....	154
47. Stern Repair Area from Port Side	155
48. Stern Repair Area looking Forward from Starboard Stern	155
49. Stern Area with Various Repair Sections	156
50. Satellite View of South Carolina Rice Country	157
51. White Oak Plantation Straddling the North Santee River	158
52. Close-Up of White Oak Plantation with Fields and Creeks	159
53. North Santee River Roughly 1 Mile Upstream from White Oak Plantation Site	160

CHAPTER 1 – INTRODUCTION

Bessie

In the year 1855, the Manigault family of South Carolina owned several large plantation estates in the Georgetown region north of Charleston. The family had deep roots in the state, where it had arrived in the seventeenth century as part of the French Huguenot immigration. Its members were well-known to contemporaries through their involvement in politics, military leadership, and their historical role as financiers for the American Revolution in South Carolina. One of their plantations, White Oak, spanned the North Santee River and was owned by General Arthur Middleton Manigault. Arthur had inherited the plantation from his father, and would eventually settle there after serving in the Confederate Army during the Civil War (Edward Manigault 2011). In 1855, before the war and ensuing devastation would alter the physical and cultural landscape, White Oak was a rice plantation like many others in the region; it supported a country gentleman lifestyle for the planters, and was supported by a large contingent of slaves who called the plantation home. The world of rice plantations revolved around water, and in addition to the Santee, the swampy property was crisscrossed by small creeks. It would also have had a complex network of canals and sluice gates to control the flow of water for rice cultivation. Around 1855, the plantation boat *Bessie* was built on White Oak Plantation as a physical manifestation of this world.

Bessie is one of the last remaining examples of a plantation boat from this region. Plantation boats of this style were once common, and one can find descriptions of such dugouts for sale in newspapers and see them in paintings, normally rowed by slaves and transporting planters. One author has referred to them as the pickup trucks of their era in their usefulness and

practicality (Wiggins, 1985:37; Bell Jr. 1987:147-149; Fleetwood 1995:112). *Bessie* is hewn from a single massive log of cypress, and features a nearly plumb bow, a mostly flat bottom that gracefully transitions into a soft and smooth chine, and a wineglass-shaped stern with a flat vertical transom. *Bessie* is 8.98 m long, has a maximum beam of 1.75 m, and a depth of hold of 0.54 m (Stewart et al. 2012:4). In its original form, *Bessie* was an elegant vessel with beaded edges on much of the woodwork, and fine craftsmanship evident throughout. The interior features 13 frames, most of which feature floor timbers with futtocks resting on them and running up the interior sides of the log. Stringers are fastened onto the futtocks, which then support seven thwarts that run from the bow to just aft of the midpoint. Small rising knees affix the thwarts to the interior of the hull. A large centerboard trunk was added at some point during the life of the vessel, and bisects two thwarts and pairs of floor timbers. The sailing rig also features a long keelson-like plank with mast steps cut into it, and a similar mast partner that runs atop the thwarts. Both the mast step and partner are in two parts, divided by the centerboard trunk. Five oarlocks are cut into the gunwales that run along the top of the log edges, and the upper works are further complemented by a rub rail just under the gunwale and an intermittent washstrake near the bow and stern. A small deck has been built in the stern section, and although the sternpost and rudder are missing, it is clearly a location for the helmsman. There are numerous other repair areas throughout the vessel, which has been heavily patched in the bow and stern both during the active life of the vessel and later. Although additional details will be discussed in later chapters, this work is not intended to be a detailed technical description of *Bessie*, which can be found in the unpublished writing of the East Carolina University team that recorded the vessel in 2010 (Stewart et al. 2012), or in an upcoming article on the same subject.

Today, *Bessie* belongs to the Charleston Museum in downtown Charleston, South

Carolina, and resides on wooden blocks in a courtyard. After White Oak plantation was sold to the Kinloch Gun Club in the early twentieth century (Linder and Thacker 2001), J. Cordes Lucas took possession of *Bessie* and donated it to the museum collection in 1926 (Charleston Museum 1926). Although he provided some basic information of ownership, few other details of *Bessie* are known. Figure 1 shows *Bessie* at the museum. Appendix A contains numerous additional photos and diagrams from different perspectives.



Figure 1: *Bessie* at the Charleston Museum (photo by author 2013)

In 2010, graduate students from East Carolina University used both traditional recording techniques as well as total station laser technology to create an archaeological recording of the vessel. *Bessie* had been recorded before (Fleetwood 1995:111), and is often used to train students in boat recording methodology (Harris 2014:70). The new recording generated some fifty pages

of documentation, as well as a digital point cloud for the lines, and edges of each shape and timber that comprise the vessel. This is a relatively new form of archaeological recording that is currently in use by the Program in Maritime Studies at East Carolina University as well as several other archaeological investigations worldwide. The roughly 1500 data points recorded on *Bessie* can be used to create a digital model of the vessel using the three-dimensional modeling software Rhinoceros. This project will use this point cloud along with the additional documentation to create a reconstruction of *Bessie*, and then use this model to both explore the role of this vessel within a historical context, and evaluate the practicality of this methodology for future work.

Research Questions

The primary goal of this project is to explore how plantation boats fit into Southern plantation culture. The secondary goal is to evaluate the total station recording and Rhinoceros modeling processes for practicality and usefulness for archaeological investigation. The research questions thus fall into two broad groups that can be addressed throughout this work, focusing on cultural understanding and methodology respectively. It is hoped that all of the questions can be answered with a harmonious combination of both historical and archeological research. The historical side both provides the context and helps establish what questions should be asked and answered about *Bessie*'s use and origins. Likewise, the archaeological research will provide data to evaluate historical anecdotes, and guide the course of historical research through its findings.

The cultural questions around *Bessie* stem from a central theme – namely why does *Bessie* exist in the form that it does? Although plantation culture has been heavily studied by researchers in various fields, there is no real conclusion as to the place of this vessel within this

cultural landscape. What were the primary functions of boats like *Bessie* by 1855, and how was it designed to fulfill them? How successful was *Bessie* as a boat, and what kind of capabilities did it have in different conditions? Why was *Bessie* built as a dugout rather than a plank vessel that is better associated with its form, and who were the boat builders that crafted it? Where did this boat building tradition come from? Is it a reflection of African heritage brought from the slave community? Native American heritage from the early days of settler contact and interaction? French and European heritage brought by the Huguenot settlers? How did *Bessie*'s design reflect southern culture, if at all, and what did plantation boats mean to planters? Were plantation boats status symbols in antebellum South Carolina, and if so how were they significant? All of these questions will help the historian and archaeologist better understand both this type of vessel and by association the society and culture that produced it.

The methodological questions mostly concern the potential benefits and pitfalls of three-dimensional reconstruction with both Rhinoceros, and the plug-in naval architecture software Orca 3D. There are some distinct philosophical and theoretical advantages to this methodology that will be discussed in future sections, but is this a practical and useful way to go about a reconstruction project? Concerning the potential, what kind of information can be gleaned from both creating and possessing a digital model and how can this best be used? Is Rhinoceros reasonably capable of vessel reconstruction, and what kind of answers can Orca 3D provide in terms of vessel capability? What uses are there for the model beyond the technical reconstruction and research? Is this a useful tool for education or public outreach? What kind of future work would be useful to better this process, or maximize the utility of this form of reconstruction? These questions directly correlate to the cultural questions, and will thus be answered in the process of archaeological investigation.

Outline

The questions above will be addressed in this and four subsequent chapters. This chapter will outline the project, and address the theoretical antecedents for this line of study. It will also touch on the available documentary sources, and on the methodological approach to both the historical and archaeological work.

The second chapter will set the scene for the project, and explore both the historical setting of rice plantations in antebellum South Carolina, and the specific history of White Oak Plantation and the Manigault family. It will draw heavily on documentary research from archival materials related to the Manigaults, and will be less focused on *Bessie* than the context, both cultural and environmental, that resulted in *Bessie* being built and used. It will also touch on the knowledge and training of slave craftsmen and their history as carpenters and boat builders during this period.

The third chapter will explore the archaeological methodology that was used in great detail. It will begin with a detailed description of the recording process, and by extension the data set that was used for this reconstruction. It will continue with an explanation of how a piece can be modeled in Rhinoceros, followed by a step-by-step example of modeling a rising knee. It will conclude with some general observations about the strengths and drawbacks of this general methodology without specific reference to *Bessie*.

The fourth chapter concerns the actual model, and will describe the decisions that went into modeling the most important aspects of *Bessie*, particularly the hull. It will also touch on the specific challenges of recreating this vessel, and how these were approached throughout the process. An analysis of the hull form, repair sections, and by extension model usefulness follows. The chapter concludes with a look at *Bessie*'s capabilities and stability with data generated in

Orca 3D.

The final chapter explores cultural influences visible in *Bessie*'s form through the reconstruction and historical efforts, and then pulls together the documentary and archeological evidence to further analyze the use and meaning of plantation boats in Southern culture. It concludes with some final observations concerning the practicality of this research, and suggestions for applications of digital reconstruction and future lines of work.

Hypothesis

Based on the design features and shape of *Bessie*, plantation boats were not intended to be commercial or economic vessels. Although they were certainly practical for transportation and capable of moving moderate loads of cargo or people, they are as much an expression of culture as a result of functional need. The shape and structure of these vernacular watercraft suggest that despite being produced by a culture of vibrantly mixed societies, they follow a generally European design. *Bessie* was designed for speed and efficiency, and to show off the wealth and status of the planter. Boats such as this would be a subject of pride demonstrating the resources of the planter and plantation, and the skill of the bondsmen who handmade the vessel.

This methodology shows great promise, but has limitations in the context of this project. Digital reconstruction offers the archaeologist a new lens for exploring vessel capabilities through programs like Orca 3D, but only if the results are contextualized for the anachronism that they are; artifacts such as *Bessie* would not have been designed or built with the modern tenets of naval architecture. This data set is relatively damaged in terms of quality, and this limits the accuracy and extent of this line of research possible for *Bessie*. Regardless of this, the model is extraordinarily useful as a way to better explore, view, and understand the construction of the

vessel. The parallels between the reconstruction process and the original crafting allow for greater academic understanding of the artifact, and a form of emotional appreciation: a non-cognitive understanding of the craftsmanship represented by the physical object.

Literature Review

The broader historical and archaeological subjects incorporated into this thesis have all been covered to some extent in secondary literature in the past hundred years. Innumerable scholars have either focused on or touched on rice plantations and slavery, slave craftsmanship, and boat building traditions of coastal South Carolina. Although these topics often overlap, only recently have scholars begun to tie these themes together. This detailed case study of a single vessel will help contribute to broader understandings of how these worlds intersect.

Authors began writing histories of rice plantations near the start of the twentieth century, several decades after the decline of this economy in South Carolina. Several early descriptions of plantations and plantation life were written either by those who formerly owned or lived on plantations or in many cases their immediate descendants. One example of this type of work is *A Carolina Rice Plantation of the Fifties*, which combines journal entries of a planter with historical research and watercolors from a descendant to portray a happy and tranquil way of life for both planters and bondsmen (Smith et. al. 1936). Similarly, David Doar's (1936) *Rice and Rice Planting in the South Carolina Low Country* provides an early secondary description of how plantations functioned in the antebellum era. As is typical for Southern history of this era, Doar is unapologetic about slavery and laments the loss of this pleasant and fruitful way of life.¹ A later generation of historians focuses not so much on the social interactions of the plantations,

¹ *American Negro Slavery* by U. B. Phillips (1918) is the defining work for an era of historians who presented slavery as a productive and mutually beneficial system for all parties.

but simply attempts to document the coastal regions of South Carolina in this era. Alberta Lachicotte (1955) writes about the plantations themselves, as do Linder and Thacker (2001). George C. Rogers Jr. (1970) is more general but extremely thorough in his comprehensive *The History of Georgetown County, South Carolina*.

A final trend in documenting this period is to focus on the social interactions of markets and slaves in the rice regions of South Carolina. One of the most important works in this field is *Black Majority: Negroes in Colonial South Carolina: From 1670 through the Stono Rebellion* by Peter Wood (1974). Wood analyzes the evolving role of blacks in colonial South Carolina and their changing relationship with whites as the economy changes and the colony grows. While this describes an earlier era of South Carolina history, it lays essential groundwork for many later scholars. In *Rice and Slaves*, Daniel C. Littlefield (1991) looks at slavery and the slave trade as they relate to the South Carolina rice economy, and explores how different slaves were valued for their skills and their home regions in Africa by exploring white relationships with slave ethnicity. In his article "Slave Independence and Enterprise in South Carolina, 1780-1865," Loren Schweninger discusses how slaves on plantations exercised independence by utilizing waterways for extra-legal economies and running from slavery. Bernard E. Powers Jr. (1994) examines slavery in Charleston, and explores the complex social relationships between whites and blacks while looking at how slaves lived and worked in a city economy.

Numerous scholars have authored histories of slave craftsmanship, and most historians of slavery at least touch on this subject. Leonard P. Stavisky (1958) made artisan slaves the focus of his doctoral dissertation. He discusses how artisan slaves were trained and used at great length and discusses the social implications of educating bondsmen and teaching them trades, but is dismissive of the importance of skills that slaves may have brought to America from Africa or

elsewhere. Mary A. Twining (1976) and James E. Newton (1977) both explore how slave origins may have contributed to their artistic ability and craftsmanship, and scholars have continued to explore this idea since. Folklorist John Michael Vlach (1976a; 1976b; 1978; 1981; 1991) has authored numerous works arguing that slave traditions from Africa or the Caribbean have influenced American styles of art, craftsmanship, and architecture. All of these authors present compelling arguments concerning how ethnic origins may have trained or influenced the slaves in their craftsmanship, but few discuss boatbuilding with any certainty. Vlach (1978) uses boats as part of his broader argument, but shows his inexperience with nautical detail by incorrectly describing some elements of *Bessie's* construction. Wood (1974) and others discuss boatbuilding training, but generally in terms of city-slaves rather than those on plantations, and without great detail.

Several scholars have researched boatbuilding in Antebellum South Carolina as well as the history of dugout vessels as a whole. William Fleetwood (1995) is the premier scholar of small boats of the southeastern United States, and discusses the various forms of boats and boatbuilding traditions in this region and time period. Michael B. Alford (1992) is also an expert on North Carolina watercraft, and writes about the various forms of cypress-built boats that could be found in the coastal Carolinas, and argues that the French connections of settlers are the best explanation for the eventual form of vessels. Lynn Harris (2002) has written numerous articles on different dugout canoes recorded throughout the Carolinas, and the different forms and possible origins of different artistic styles. Her most recent work, *Patroons and Periaguas: Enslaved Watermen and the Watercraft of the Lowcountry* (2014) is the best synthesis of how different cultures and boating traditions contributed to the vernacular style that defines the South Carolina maritime cultural landscape. Daniel Brown, Kathryn Cooper and Lynn Harris (2011)

describe one of the best comparison vessels for *Bessie* in their documentation and historical contextualization of the plantation boat *Accommodation*. Although this vessel is a split-log dugout and was built earlier, there are many comparisons to *Bessie* in construction style and use. Jessica Lee Curci (2006) also writes about the form of southeastern logboats in her dissertation. She addresses the impact of environment and locality on logboat forms, in contrast to studies focusing on the importance of culture or geography. Each of these works address *Bessie* in some form, but none of them can fully explain the circumstances and choices that led to the creation and use of this particular vessel. Harris's work (2014) is the closest in terms of subject matter, but still focuses on the broader cultural tableau rather than the world of the rice plantation and plantation boat.

While scholars have written about most of the individual components of this study in one form or another, no work has focused specifically on the boating and boatbuilding culture surrounding the plantation boat. Each area of study relates to each other, and *Bessie* is an ideal case study to explore the interconnectedness of these themes in Southern history. The unique level of *Bessie*'s preservation combined with the reconstruction should aid in addressing the cultural importance of this vessel. Previous studies of the rice economy, slave craftsmanship, and regional boatbuilding practices will be essential for understanding possible influences for *Bessie* and the culture around it. Relevant literature will be discussed in greater detail in each applicable chapter and section in which it is utilized.

Theoretical Framework

This project will be guided by two main theoretical frameworks: material culture studies and ship reconstruction studies. Material culture theory is basically the idea that artifacts are

more than just physical reminders of the past, but can in fact be used to study culture. Artifacts are material remains, but they reflect the beliefs and ideas of the society that produced them. Material things have intrinsic importance to humans as a way to stabilize and structure our lives, define our place in social hierarchy, and force us to think about how we relate to other people. In other words, artifacts of any society are permeated with meanings. These meanings change with different peoples, times, and places, so deciphering the meanings of artifacts can help reconstruct the culture the artifacts came from (Csikszentmihaly 1993). Deciphering these meanings is not always straight-forward, but as Jules Prown has noted (1988:22-23), artifacts are not randomly produced. Their form is influenced by the traditional way such things have been created in that society, the beliefs of the society that ensure they are created that way, and the individual flair or choices of the actual craftsman. By carefully analyzing an artifact and how it is made, an archaeologist can learn about a culture from the choices that were made in producing it. James Deetz (1977: 35-36), a pioneer in historical archaeology, provides a very broad definition of material culture: “that sector of our physical environment that we modify through culturally determined behavior.” In other words, he sees material culture as the way humans interact with and modify their environment, and thus can include basic tools or artifacts, but also modifications of natural settings like planted trees, dammed streams, or even livestock like horses that have been specifically bred to pull a plow. All of these environmental adaptations reflect the values and ideas of the parent culture. Material remains are effectively the product of culture, and can thus be used to reconstruct cultural ideology.

Material culture is not a distinct field of study, but is tied into many other fields including archaeology, sociology, history, art history, ethnography, and folklore (Schlereth 1985:6-7). Many of these fields deal with the study of physical objects in different ways, and attempt to

understand the meaning behind the physical. Simon Bronner (1986:26) argues that while humans have a natural instinct to divide the mental from the physical, such a split is not so simple. Physical things cannot be divorced from their mental meanings and connotations. Objects call ideas to mind or represent values, and are intentionally used to do this: souvenirs can thus be purchased to remember specific vacations, and wedding bands can be worn to symbolize fidelity. Such meanings are important for the culture that created artifacts and can be understood in the shape of the artifact, the materials it is made from (for example, gold has no more inherent value than any other material, but is culturally granted value for its rarity and beauty), and the context it was created or given in (Friedel 1993). Jules Maquet (1993) notes that there are several levels of interpretations for artifacts that denote how culturally specific meanings actually are. For example, an instrument artifact can be understood or interpreted with relative ease; an unearthed shovel has a clear utilitarian purpose and could probably be understood by most humans who found it. At the far end of the spectrum are referents, or arbitrary symbols entirely based on cultural association; unlike a shovel, an excavated crucifix would be entirely impossible to understand if the researcher had no knowledge of Christianity or outside sources to aid in interpretation. In general, artifacts have multiple layers of meanings that can often only be understood in context, but that can provide further insight into the meanings and practices of a culture.

Folklore is a field closely tied to material culture theory which emphasizes the meanings and values placed on artifacts and especially handcrafted items. Simon Bronner (1986:15) defines folk as something learned informally or by tradition as opposed to learning through formal education or training. Modern students of folklore often emphasize the importance of process in creating an object, and have moved towards practicing ethnology in studying how an

actual object is made to understand the choices that went into production. Michael Owen Jones (1993) notes that culture is very important in making these choices, but that individual interests and personal style are also important. The analysis of any handmade object requires that one consider the technology and materials available to produce it, the style and influence of the crafter, the needs and wants of the consumer the object is intended for, and the requirements for the object to be functional in its intended use. The process of crafting is as important as the final result, and as society is increasingly industrialized handmade objects are prized more and more highly and individual craftsmen value the crafting as much as any artist. Creation is a cognitive and sensual experience, and so the experience of craftsmanship is as important as the object itself (Bronner 1985). Folklore's emphasis on this process and the importance of this to the creator can help shed light on the cognitive and culture influences that went into shaping archaeological artifacts.

Henry Glassie (1999:78) argues that similar importance needs to be placed on artifacts of the industrial age even though they lack the handcrafting process. While there are no individual choices in craftsmanship in machine-made goods, there are patterns of collection, use, and modification that can be equally important. In a landmark study incorporating similar notions, Bruce A. Lohof (1982) has shown how objects as mundane as prefabricated service stations can illuminate key traits of American culture in the mid-nineteenth century. The themes of simplicity, mass-production, and convenience (not to mention automobile culture) are all hallmarks of post-war America, and as time progressed these basic traits of service stations were adapted to the changing market with more emphasis on pleasing aesthetics and local needs. He describes this as a vernacular tradition: the basic premise of easy interchangeable and convenient construction is modified to fit the time and locality, but remains in its fundamental idea.

Vernacular architecture is a closely related area of study that examines how building forms exist and persevere against a backdrop of popular or rapidly shifting broader trends (Upton 1985). As with folklore and the general ideas of material culture, the focus is more on the individual and local customs than on trying to define entire cultures with one structure or object. One can understand cultural trends by the way in which architecture changes in broad or subtle ways, and the ways in which it stays the same. Lohof's study is an excellent example of how the vernacular tradition of simplicity and mass-production remains during a cultural shift towards local needs. In simpler terms, the form of the architecture follows its function, but the vernacular tradition remains.

All of these examples come from the historical period, and one might question why material culture studies are valuable in an age of extensive historical documentation. Prown (1993:7-13) argues that material remains allow a researcher to analyze the past in a way that remains impossible with documentary sources. He argues that the inherent bias in a modern mind can be bypassed with the emotional reaction humans have to an object. Analyzing emotional response is an inexact method at best, but can help raise questions and ideas about form, use, and meaning that thinking cannot. Bronner (1986:2-7) notes that humans are very tactile by nature, and seeing or touching something conveys meanings that mere words cannot. Glassie (1999:43-47) discusses artifacts as a language equivalent to words. Illiterate people throughout the ages have expressed themselves in the act of creation, and artifacts, though not always easy to understand, allow researchers to access broader populations than texts can allow. Material culture is in essence an entirely distinct but complementary record of history, and the best understandings of the past come from the effective combination of documentary and material sources. Little can be understood from excavating a small house with no context about who lived

there, but having documentation showing the house as belonging to an escaped slave community can make it a valuable archaeological site where the material remains can shed light on what might be an otherwise voiceless community (Ascher 1982). Material culture is most valuable when used in conjunction with historical documents, and when used well it can reveal the past in ways that documents never can. Carroll W. Pursell Jr. (1985) in his study of the history of technology discusses the importance of the actual artifact to make impressions on the researcher. There can be no written, photographic, or other substitute for standing near the massive machines of the nineteenth and twentieth centuries and being impressed by their mass and complexity in a way that would likely have impressed the original workmen. The importance of this physical presence is why people flock to museums to see ships, planes, and other large artifacts that could easily be found in pictures online, and helps show how researchers can gain unique and otherwise inaccessible understanding through the study of artifacts.

While the importance of material culture is thus evident (and closely resembles the foundation for archaeological study as a whole), how to study it is still rather difficult. Prown (1993:7-13) has noted that a close study of material remains will often raise questions and inspire the researcher with ideas and avenues to pursue that could not be gleaned from documentary sources. Glassie (1999:47-58) presents a somewhat more straightforward approach that involves analyzing three main categories in an artifact's lifespan. Context is key for any artifact, and the first category is creation. A researcher needs to consider the availability of technology and resources, but also how the creator was trained, what influences went into the creation, and what the creating process meant to the artist. The second category is communication, and is the stage where the object is transferred to a new owner or user. This would obviously not exist for every artifact, but is a key aspect in considering how the object is advertised, how the creator

communicates the different values it has, and how it will come to be understood by the new owner. The final category is consumption, and is how the artifact is treated and understood by the consumer or user. This is separate from the values and associations of the creator, but overlaps in the communication area. As an artifact ages, it gains more and more interpretations particularly each time it passes into new hands, and even when it is discarded. By thinking about the meanings and values associated with the artifact in its context at each individual stage, researchers can best understand what the artifact can tell them about its parent culture.

In terms of this project, *Bessie*'s shape may reflect a specific boatbuilding tradition, while the details of craftsmanship can be used to think about the relative importance of utility and exhibition in a planter class society. The importance of *Bessie* to the owner is at the center of these research questions, and the associations and meanings carried with the vessel are critical for understanding its role in Southern culture. The slave craftsmen and rowers are integral to understanding this vessel and this culture, and although they remain largely silent in the historical record, their contribution remains in the archaeological record in *Bessie*. This can prove invaluable for understanding how they went about creating and the value they may have placed on their skill and ability in crafting a large and technically difficult object. The influences that went into the design of *Bessie* could be critical for understanding how this population in slavery adopted and combined the different cultural practices and traditions they were raised with and subjected to. Folklorist Michael Vlach has already studied shotgun houses in Texas as a combination of African, Caribbean, and other cultural forms in a very similar fashion (Upton 1985; Vlach 1976).

Perhaps the best model for how to approach *Bessie* comes from Robert Ascher (1982), who has proposed the idea of the superartifact. A superartifact is basically a particularly

excellent lens for understanding a culture. It is particularly adept at telling researchers about the people being studied, and has greater potential for understanding than other artifacts around it. For instance, cars in American culture are not just relevant for the technology and transportation forms they show, but can symbolically represent American culture in their use, their representation of social status, and their symbolic importance in American tropes of independence, freedom, and the excitement of the open road. *Bessie* is not just an example of craftsmanship and transportation, but represents the importance of status and privilege for planters and likely also the slaves involved in the construction and use of the vessel. In the water bound world of rice planting, *Bessie* has basic utilitarian functions but is also the ideal form to represent meanings and symbolize status for the planter and plantation. In this sense, *Bessie* could be considered a superartifact, and should be studied as such from a material culture standpoint.

Ship Reconstruction is a subfield of nautical archaeology, and is in many ways based on similar principles to material culture theory. Frederick H. Van Doorninck Jr. pioneered this field with his extremely detailed examinations of fragmented ship remains (For an example see Van Doorninck Jr. 1982). These are then interpreted with the simple idea that ships were built the way they were for specific reasons, so carefully analyzing how a ship was built can help you learn about the society that produced it. J. Richard Steffy (1982a, 1994:8-12) started working along the same lines and helped develop it into a subfield of maritime archaeology. The shape of the hull can tell you where and how it was intended to be used, and the construction details can tell you about the technology that the building society possessed. Frederick M. Hocker (2004:6-8) has built on Steffy and Van Doorninck's work, and nicely summarizes the importance of the shipbuilder's philosophy. A ship's design can tell you how the builder conceived of his vessel,

and how it fit into his worldview. His approach to shipbuilding reflects the necessities of his society, as well as his cultural beliefs and assumptions about how the vessel should be built to perform its tasks optimally. Although it is easy to get caught up in a study of technology and details, Hocker (1991:1) emphasizes that reconstruction is ultimately still a study of people. The details of technology and construction can reveal much about the social, labor, and economic conditions in the parent culture. In this way, society can be studied through its ship construction.

J. Richard Steffy and Frederick H. Van Doorninck Jr. (Steffy 1982a; Van Doorninck 1982) demonstrate how to accomplish this in their study of the seventh-century A.D. Yassı Ada shipwreck. They reconstructed the hull shape with a series of models, and in doing so learned a lot about the state of seafaring in the Mediterranean during the seventh century. A narrower hull and bow shape implied that the ship was built for more speed than they would have expected, and this was interpreted to match historical accounts of increasingly dangerous sea travel during the period. The build of the ship seemed much lighter than might have been expected, but this helped show what kind of sailors Byzantines were in this period and what kind of conditions the ship was and was not expected to sail under. In short, the reconstruction was used to answer broader research questions about seafaring culture and history.

Reconstruction can be done in many different ways, ranging from lines drawings to scale modeling; but three-dimensional research is particularly useful. Steffy (1982b; 1989) has long advocated three-dimensional modeling, and while new techniques have become available with different technology and computer aided modeling the basic advantages of doing so remain the same. A three-dimensional model allows one to visualize a vessel or site in a way that is rarely possible in the field especially if the site is underwater. More importantly, the process of constructing the vessel can solve mysteries and present new questions that could never be

understood by simply looking at an artifact. Similarly to the importance of process in understanding artifacts with folklore and material culture studies, reconstruction allows the researcher to actually experience to some degree what the shipbuilder experienced. In their reconstruction of the Yassı Ada vessel, Steffy and Van Doorninck (Steffy 1982a:84-85) found that what appeared to be an odd shape of hull made sense when they began as the original builder did and proceeded with the construction sequence. Similarly, when reconstructing the Serçe Limanı vessel, Steffy (1982b) found that he could use scale replicas of the archaeological remains to understand the sequence the vessel was constructed in by seeing how they could or could not fit together and stay together based on the order of assembly. This sequencing helped him better answer his research questions about the transition from shell-based to frame-based ship construction during this period. In this case the reconstruction was completed while the actual remains were simultaneously being re-assembled for display, and each of these processes helped the other in determining how to reassemble and understand the vessel (Matthews in Steffy et al. 2004:126-129). The actual remains revealed things the models could not, but the models allowed the researchers to begin assembling the remains and helped them better understand how everything fit together. Christian P. P. Lemée (2006:102-103) notes perhaps the most basic advantage of three-dimensional models in that they are representing the ship as it was built. Any two-dimensional representation or description cannot fully do justice to the complexities of curves that encompass a ship, and so understanding the vessel can best be done by recreating the vessel in its original form with all three dimensions present.

There is also vast potential in using models to better understand the characteristics of vessels that could never be otherwise understood without a full scale replica. Steffy (1989:249) has utilized full scale replicas and experimental archaeology in the past, but is the first to admit

that it is very difficult to justify the time and expense needed for such an undertaking. Seán McGrail (1988) has experimented with utilizing the principles of naval architecture to better understand vessels. He has used reconstructed lines drawings to analyze the capabilities of ancient vessels with hydrostatic calculations. This is the same fundamental approach that a digital reconstruction will allow with *Bessie*. There are tremendous advantages to using models in this way, but there are also huge dangers in incorporating modern design techniques into studies of the past. Along with McGrail, Ole Crumlin-Pedersen (2006) has discussed the problems with assumptions that can be made by using this technique. Among other things, the reconstructor may be tempted to project modern standards onto ancient vessels. For example, the industrial age has trained us to think in terms of straight lines and precise angles, while a carved boat would have little need for such things. They might, for example, choose a curved keel over a straight one for the added strength in an arcing shape. Archaeological degradation might make one think this was a product of site formation rather than a conscious choice given that most modern ships begin construction with a straight keel. Similarly, there is a tendency for modern seafarers to think only in terms of whether sail, oar, or steam will propel a ship fastest, but ancient mariners may not have found that to be the most important factor. They also would have taken advantage of several passive propulsion methods as well as tides and currents that would influence design and shape.

On the whole, McGrail and Crumlin-Pedersen (2006) advocate adhering to the principle of minimum reconstruction. This basically states that one should never reconstruct more than what you can do from the archaeological remains with great confidence. A reconstructor should be aware of the limits of what the remains can reveal, and should never make assumptions about shapes or technology without solid evidence derived from the remains, or directly comparable

sites or sources of information. Crumlin-Pedersen (2006) uses a reconstruction of the Dover boat as a case study for the dangers of assumption. The original reconstruction of the craft theorizes straight lines or flat surfaces in many areas where tool and wear marks suggest the boat was never actually or intended to be built that way. Additionally, several calculations of speed and capability are either contradicted by documented experimental archaeology or do not necessarily match historical practice. For instance, the reconstructors theorize the boat could not have been used in the English Channel due to its poor caulking and structural integrity, but base this on modern safety standards for what would be acceptable. Effectively they show that there is tremendous potential in reconstruction studies, but conclusions must be placed in the context of the parent culture and modern ideas cannot be projected onto historical peoples.

Computer modeling is a relatively new technique that shows great promise but also has some disadvantages over physical model construction. Steffy (1989) worked with computer modeling to some degree, but found it lacking in one essential characteristic. Wooden modeling helped show the reconstructor what was actually possible to do with wood in a way a computer cannot. For instance, Bass and Van Doorninck (1982:68) determined that their original lines drawing for the Yassı Ada vessel was wrong when they could not get a replica plank to bend in the necessary fashion to be secured into the rabbet. In this way, the model revealed something a lines drawing could not. While a computer can replicate many of the things a physical model can do, it will bend digital planks in ways that real wood could not, and will thus not provide quite the same level of information as a physical model. That being said, there are numerous advantages. Lemée (2006) discusses the benefits of using models in public outreach, education, and demonstration as a digital model is ideally suited for this in the internet age. A single digital model can also serve the same function as several physical models by allowing the researcher to

resize everything in an instant, and show only the details they are interested in at any given point.

In terms of *Bessie*, a digital model can be used to determine several things about the vessel. Reconstructing it can help the researcher understand the complexities of the design as well as the difficulties in the particular form of dugout construction. The same basic principles of reconstruction apply in terms of learning more about the process of construction and the difficulties of piecing the vessel together even if the actual process is not completed in the same way. The model can also be used to assess the properties of the vessel, which can be used to determine intended function and use. This will in turn help shed light on what the designers and builders were thinking when they constructed *Bessie*, and therefore what roles *Bessie* was intended to perform in Southern plantation culture. As with any reconstruction, there are dangers of modern projection of ideas and interpretations that suit our industrialized society better than one based on handcrafted goods as outlined by Crumlin-Pederson and McGrail (2006), but the principle of minimal reconstruction combined with a careful consideration of what is appropriate for the context of *Bessie* should help alleviate these potential concerns. This project will also help test the practicality of digital reconstruction as well as the usefulness of the process. The completeness of *Bessie* allows for a fairly comprehensive reconstruction which should be able to reasonably assess the potential for complete digital reconstruction for future use.

Historical Methodology

The primary historical approach to the cultural questions will be a case study of the Manigaults, and a comparison with other sources concerning boat building and use in this region and period. The Manigaults were a prominent part of the planter class in this region, and they left a multitude of records concerning plantation boats that can provide insight as to how these

vessels were built and used. The South Carolina Historical Society in Charleston houses a collection of records from the Manigault family (collection 1068.00) including letters, legal records, and several journals from different family members (Manigault Family 1971). These journals detail daily lives, plantation activities, and occasionally much more. Though none of them seem to make boating a primary concern, they do discuss boats along with other activities. The daily interactions with these vessels can shed light on what role they played in plantation life, and how they were used and viewed by the planters. Many of these references are extremely vague, but still can be useful in the terminology they employ and how they discuss usage. This project will also explore other sources and plantation records in order to compare boats' usage on different plantations (Doar 1936; Smith et. al. 1936; Alston 1953; Uya 1971; Bell 1987; Elliot 1994; Douglass 2002). Several journals concerning rice plantations and boating have been published, and many more are available in archives throughout the Carolinas. These can be compared with Manigault records to fill in gaps left by the case study.

Historical sources will also be examined to see how cultural influences affected *Bessie's* construction, and will help in comparing the artifact to boat styles from other boat-building traditions and exploring where and how slaves would have learned to build vessels. Numerous authors (Vlach 1978; Alford 1992; Harris 2002) have conjectured that African, Native American, and European boat-building traditions influenced the style and construction techniques in this region, and this study will compare the shape and construction style of these boats to *Bessie* in order to help determine what traditions shaped the conventions. Most authors have approached this subject through studies of cultural contact and dissemination of peoples and ideas, but this study will use reconstruction techniques to add to the conversation as discussed below. There are numerous secondary sources that discuss boats in these different regions, as well as travelers'

accounts and sketches of vessels that can be directly compared to *Bessie*. Slave craftsmen and artisans will be an important part of this section considering they were likely the builders of *Bessie* and similar boats. If they relied on traditions learned in Africa and passed down through slavery, this would likely have been an important factor. If they were trained by white boat-builders in Southern cities (as many slave artisans were) or simply directed by owners in their manual labor, this could point more to European influences. Slave sources will be difficult to use since very few slaves left written records, but some of their training should be traceable in owners' records. There are also available the transcripts of oral interviews of slaves conducted by the Works Progress Administration; and while research with this source has not proven particularly fruitful, they reveal slave voices in a way of which few other records are capable (Library of Congress 2001). There are also some accounts from escaped or former slaves (Uya 1971; Douglass 2002) that discuss training as artisans or as even shipwrights that will prove useful.

All of these historical avenues of investigation will be used to address the cultural questions. By exploring how boats like *Bessie* were used, treated, written about, and discussed by the Manigaults and others, they can be placed in a context of plantation culture. The symbolic importance of such vessels can be discerned with an understanding of their use, design, and treatment in documentation. Secondary literature concerning planters and their culture will be very important for this part of the study in order to integrate boats into the broader spectrum of Southern plantation culture. The broader goal of all of these questions is to explore the role that plantation boats played in this culture. The Manigault family and *Bessie* are ideal candidates for exploring this idea.

Archaeological Methodology

As the Manigault family records will be the core of primary sources for the historical investigation, so *Bessie* will be the core of the archaeological side of this project. These multiple angles of investigation will result in a holistic study of this culture. Completing the digital reconstruction of *Bessie* will be the primary archaeological means of addressing many of the cultural research questions, and will also serve as a basis for exploring the process and testing the capability of this technique. Rhinoceros is a powerful tool that allows a user to start with a point cloud, and build complex three-dimensional shapes. The points are already organized into layers that were created before and during the *Bessie* recording process, and the points for each type of timber can be quickly isolated. Using the accompanying photos, sketches, and the catalog of points as a guide, lines and curves can be used to start connecting points. These can then be used to form a wireframe of each individual object that can be covered with an appropriate surface. Once a feature has been completely surfaced, a three-dimensional collection of connected surfaces can be used to construct a solid shape. The shape can be textured with wood-grain taken from photos of *Bessie*, and therefore appear in digital form very much how it does in real life. The reality of this process is that the point cloud is imperfect when there are problems with using the total station, or some points are impossible to target. The tools are powerful, but human error and physical impossibilities do limit the ability of recorders to create an ideal point cloud. These issues must be accounted for by the modeler, and the accompanying sketches and measurements help reconstruct incomplete shapes in conjunction with the points that were accurately recorded.

While Rhinoceros is not a new program, using it in this way is fairly new for maritime archaeology. Several projects worldwide are currently utilizing this software, but there is no

single manual for using Rhinoceros in maritime reconstruction projects.² *Bessie* provides an interesting test subject for many reasons. *Bessie* was recorded by a team of graduate students two years before this project began, and so the modeler in this case was not directly involved with the recording. While the reconstructor has visited *Bessie* numerous times, not being a part of the original team means that the reconstruction will be an excellent test of the recording process. The modeling will be almost completely dependent on the original recording data, and the modeler can use this handicap to test if the data taken during the field school is adequate for a complete reconstruction, and if not, make suggestions for how to improve recording methodology. Similar projects in the future would also likely be using teams of students who do not specialize in reconstruction, so the quality of data collected during a field school is also of relevance in considering the viability of this recording technique. Although led by an experienced primary investigator, the newness of this technique and the inexperience of most of the recording team warrant an analysis of the efficacy of field school reconstruction projects.

Once completed, this will also be useful in answering questions about the cultural influences that went into *Bessie*'s design. When considering which boat-building tradition most influenced the construction of South Carolina dugout boats like *Bessie*, traditional sources cannot tell the complete story. Historical sources can suggest the influence that Native Americans or Africans had on boatbuilding, but this does not mean they built *Bessie* like an American or African canoe. Cultures around the world have employed dugout technology, so the ability of any one culture to construct vessels in this fashion does not mean they were in fact responsible

² Among others, Dr. Frederick M. Hocker is working on modeling the Swedish warship *Vasa* from total station points, Dr. David Stewart of East Carolina University is doing the same for the ancient Kyrenia vessel in conjunction with the Kyrenia Shipwreck Museum, and FRAUG is an international group working on several vessels worldwide. Several other East Carolina graduate students are also using Rhinoceros modeling as a part or focus of their thesis research.

for the boat-building tradition on the plantation. While historical sources may elaborate on the cultural exchanges that occurred in the settling of South Carolina, *Bessie*'s actual hull shape, its structural features, and the construction techniques utilized in building it can better determine where its design originated. In other words, there is little reason to doubt that *Bessie*'s builders could have been adherents of any number of boat-building traditions given the cultural milieu they lived in; so only an examination of the shape of the actual artifact can help clarify which tradition, if any, most influenced its construction. A digital model is the ideal tool for examining this shape. It can be manipulated in ways that allow it to be easily compared to historical sketches, images, or descriptions of other vessels coming from different parts of the world and different boat-building traditions. Having a digital model will make such comparisons easier than with the actual artifact as it can be shrunk to appropriate size or angled to match a sketch, and the structural features can be isolated with ease. In this way, the reconstruction will be integrated with the historical research to best approach cultural questions.

Another advantage of the reconstruction is the potential to use secondary or add-on software to further assess the capabilities and characteristics of *Bessie*. In particular, several companies offer naval architecture packages that use Rhinoceros as their primary modeling software. Orca3D is one such program that allows the user to create a boat in Rhinoceros, and then test everything from its stability to hydrostatic properties. Materials and density properties can be assigned to the solid shapes created in Rhinoceros, and the boat's in-water capabilities can be tested. This software may allow reconstructions to be of much greater use than artifacts in their ability to learn about how vessels would perform. This can both provide technical information about how *Bessie* could have functioned as well as work in tandem with the historical record. Weight properties, for instance, can help clarify how many people might have

been able to travel in *Bessie* or what load of cargo it could have carried if employed in that way. The in-water characteristics might also help determine what kinds of waterways it was capable of traveling in depending on the freeboard one could expect with a full group of rowers and a few passengers. The potential of this software is extremely exciting for simplifying performance calculations for historical vessels, but requires a completed model for full functionality.

The reconstruction questions involve the use of such a model as a source of education or public outreach. The Charleston Museum will ultimately control how they might want to use this model as part of their exhibit, but the potential for public education or outreach is clear considering the proliferation of the internet and its use as a research tool. The ability to supplement the artifact with an online exhibit or a digital component that can be used by patrons to interact with the vessel to learn more about its use and history is an idea worth consideration. There are also new archaeological journals exploring the idea of publishing academic articles that include three-dimensional models by moving to an online format that allows for the submission of digital projects. Recording in this way can create a record of an artifact that might otherwise be threatened or difficult to preserve. On the whole, the potential for this technique is impossible to fully realize without exploring the process. Creating a *Bessie* model can both help answer questions about cultural use and design, and provide important insight as to how this technology can be best employed in the future of this field.

CHAPTER 2: A HISTORY

Introduction

Antebellum South Carolina was one of the largest rice growing centers in the United States. In the 1850 United States census, the state claimed 446 rice plantations, and the combined yield for the Carolinas that year was over 150 million pounds of rice, the vast majority from the southern state (Smith et al. 1936:10). Rice could only be grown in specific areas near the coast, but was a huge industry that shaped both the economy and the culture. A wild version of the plant was gathered by Native Americans prior to colonization, but rice was not easily cultivated. Rice growing was first attempted by European settlers in the late seventeenth century, but they failed numerous times before managing to produce full crops. Rice had never been grown in Europe, so it took some experimentation to understand how it was best cultivated. Imported African slaves played a key role in this success as rice cultivation was common in several regions of Africa from which slaves were purchased (Doar 1936; Littlefield 1991:113-114). Newspapers ads of the time specifically noted slaves who had rice growing experience, and budding agriculturists certainly took advantage of knowledgeable labor. By the middle of the eighteenth century, rice was the staple of the lowcountry region of South Carolina, and the primary export (Wood 1974:35-36, 59-62). While there were several other industries of note in the region, rice was the dominant product until at least the Civil War.

The rice industry depended on very specific environmental conditions; rice plantations were always surrounded by, dependent on, and in many cases under water. Plantations needed to be near rivers for access to plentiful fresh water, and cultivation required periodic flooding of fields and intensive water management systems. They also depended on waterways as

transportation networks to manage their crops and eventually move them to markets and seaports for shipment. Charleston was a major port and the largest city in the region, but Georgetown also developed as a rice port and regional center in the eighteenth century (Lander Jr. 1951:131). The agricultural region surrounding and between these cities was crossed by several rivers and myriad creeks which formed a dense network of water supplemented by manmade canals. Boats played an important part in all aspects of rice planting, and various kinds of watercraft were present on every plantation.

Along with profits, the rice industry spawned an entire culture in the cultivatable region. The relative locations of plantations near cities allowed for a wealthy class of planters to enjoy the best of the city while staying near enough to manage their vast estates. The actual growing and harvesting of rice depended on African American slavery. Rice cultivation is extremely labor intensive, and it is not coincidental that the beginnings of extensive rice cultivation roughly coincided with the black population of South Carolina surpassing the white population around 1708 (Wood 1974:36). This combination of factors ultimately spawned a culture where extremely rich planters could live a life of relative ease and luxury in a water-bound world aided by a large slave labor force. The boats used on plantations were also almost always built, maintained, and rowed by slaves. Although often ignored in writings from the time, slaves were a critical aspect of plantation boating culture. This chapter will examine the Manigaults to explore the world of rice plantation life in the 1840s and 1850s. Specifically, it will be a survey of the ways in which plantation boats fit into the everyday routine and culture on a South Carolina rice plantation. This will help establish the environment and culture that produced *Bessie*.

Despite being so common, many questions remain about the vessels typically employed

on a South Carolina rice plantation. Various vessel types are referred to again and again in literature describing the region's economic activity, but very few examples have survived to present day, and the design and use of these craft are not fully understood. While the function of barges or flats used to transport rice hither and thither on the plantations is obvious, the uses of large canoe-like vessels such as *Bessie* are less clear. Were these long and narrow vessels an important part of the economy, or were they more for recreation? Were they an essential part of getting around the region, or was it possible to move about without them? Why were these vessels built as they were, who designed and built them, and what were they ultimately built for? What part did vessels of this nature play in the recreational and cultural life of nineteenth century coastal South Carolina? What role did slaves play in plantation boating? A study of *Bessie* and the Manigault family can help create a more complete picture of this world.

Using this family as a case study within the context of available secondary literature, it is possible to reconstruct the role of plantation boats in antebellum South Carolina. It is clear that these boats were extensively used for transportation and recreational purposes, but that they were also indulgences that were not essential for plantation functionality. While tremendous time and resources of both planters and slaves were devoted to these boats, documentary records indicate that their role was largely recreational and symbolic by the 1840s as other vessel types and means of transportation could easily be substituted for their use.

Manigault family records will be the primary source material for the documentary side of this chapter. *Bessie* was reputedly built around 1855 on White Oak Plantation, which was one of several plantations owned by the Manigaults. They were constantly buying and selling plantations and parcels of land throughout this period, but as a family owned over 57,000 acres in South Carolina in 1779 (Manigault Jr. 2007:40). While the build year is estimated, there is

little reason to doubt the museum records concerning the family and plantation the boat came from.³ Although White Oak's plantation house was looted during the Civil War, a large collection of family records were saved and are now safely housed in Charleston at the South Carolina Historical Society (SCHS) (Manigault 1983:1). The archive features several relevant holdings including the Manigault Family Papers and the Peter Manigault Collection. These and several related collections hold innumerable letters, journals, writings, observations, and the original Manigault family bible. The entire collection is immense, so the author has attempted to find the most pertinent files concerning the White Oak Plantation in the mid-nineteenth century, and any files regarding plantation life and boating specifically. Other plantation records and documentary archives have also been useful for understanding this family and culture, including the holdings of the College of Charleston, the Huguenot Society of Charleston, and the Georgetown Library.

Of the available sources, the most useful has been the journal of Gabriel Manigault, written between 1840 and 1842 within the Peter Manigault Collection [1745] at the South Carolina Historical Society. This journal details his travels around the East Coast before he settled down to the life of a planter, and is available as a typed manuscript as well as in the original form. Although the journal discusses several plantations other than White Oak and is not always clear about which plantation it is referring to, all are plantations owned by the Manigaults within the same region. For understanding the life surrounding the *Bessie*, these recollections should be equally pertinent regardless of which plantation Gabriel was on at any given point. Boats are rarely named in the journal, but one must assume that the use of similar boats are just

³ Information on the museum's intake records indicate that the boat was only once removed from the family when donated and the plantation's identification came from the Manigaults, but that the age was just estimated at 70 years when the boat was donated in 1926.

as relevant to plantation culture as any specific references to *Bessie*. This is the single largest source of material, but many other letters and journals have been used in this research as well.

To supplement these collections the author has explored numerous sources relating specifically to rice planting in this time and region as well as myriad secondary works. Among the more useful publications of primary writings are J. Motte Alston's (1953) *Rice Planter and Sportsman*, and D.E. Huger Smith's memoirs published in *A Rice Plantation of the Fifties*. In addition to the memoirs, the latter book contains thirty watercolor illustrations of plantation life from someone who experienced this period of Southern history firsthand. These have been very useful in representing what is otherwise only described.

There is a fairly large body of secondary literature concerning rice plantations, slave craftsmen, and dugout canoes of the Carolinas. Historians have long understood the importance of rice plantations in antebellum South Carolina, and while the various works regarding them are certainly relevant, the focus here on boats relegates them to secondary importance. *The History of Georgetown County, South Carolina* by George C. Rogers, Jr. (1970) has been more helpful than most given its focus on this particular region, but for the most part this study relies on economic descriptions provided in the primary sources listed above, and occasionally the editorial notes therein. Slave involvement in boat-building and use has not been well documented in-and-of itself, but many authors studying slave crafting, skilled slave labor, or slavery in general have commented on it. Of particular note are Peter Wood's (1974) *Black Majority* and the various works of John Michael Vlach (1978, 1991) concerning slave craftsmen and artisans. Vlach's work does discuss *Bessie* explicably, and his cultural insights are valuable though his technical observations on construction are questionable. None of these sources focus directly on the topic at hand, but they have all been helpful in conjunction with the primary sources.

Dugout canoes have been extensively studied as artifacts and evolutions of small boat construction. William C. Fleetwood's (1995) *Tidecraft* is an extremely valuable work for any study relating to small boats of the American southeast, and Michael B. Alford's (1992:191-203) article concerning Carolina dugouts has also been particularly insightful. In addition to firsthand observations, this study has made use of an as-of-yet unpublished article concerning *Bessie's* construction for understanding the craft itself (Stewart et al. 2012). Although the secondary literature is extensive, there is no complete study of plantation boating as a cultural practice. This chapter will make use of the secondary works that discuss the various skills, people, and artifacts that were involved in plantation boating, and use a case study to bring them all together in the planting world of the Manigault family.

The Manigaults, White Oak Plantation, and *Bessie*

The Manigaults were one of the most prominent and affluent families in colonial and antebellum South Carolina (Rogers 1970:20). The family originally came to the New World from France to escape religious persecution around 1692, and was one of many Huguenot families to settle in the region (Manigault Jr. 2007:59). Gabriel Manigault was the richest man in South Carolina during the colonial period, and he was largely responsible for funding the revolutionary efforts of the colony. After the revolution, the Manigault family was important enough to send two delegates to the South Carolina convention to ratify the United States Constitution. The Manigaults of the nineteenth century featured a number of wealthy and prominent men in the state, including signers of the declaration of succession for South Carolina and a Confederate general (Manigault 1983:IX; Manigault Jr. 2007:12, 16-17, 41). The historic house of Joseph Manigault in Charleston is now an asset and showpiece for the Charleston

Museum, and they were large landowners in the greater Charleston-Georgetown region. The family was tied to many of the other prominent families in the state, and a cursory glance through any general history of South Carolina will reveal plenty of references to prominent names such as Middleton, Izard, Drayton, Pringle, and Huger, all of which appear in Manigault family papers in one generation or another (Manigault Jr. 2007). Suffice to say that the Manigaults were very well connected, and represent the elite of South Carolina planter society in the antebellum period.

The specific family members of relevance to this study are Joseph Manigault (1763-1843), and his sons Gabriel Manigault (1809-1888) and Arthur Middleton Manigault (1821-1886). Arthur's son Arthur M. Manigault II (1851-1924) was also an eventual owner of White Oak and *Bessie*. Joseph Manigault was a prominent citizen of Charleston, and the grandson of the extremely wealthy Gabriel Manigault (1704-1781) of the colonial era. After fighting in the defense of Charleston during the Revolution and studying abroad, he inherited vast estates in South Carolina including what probably became White Oak Plantation (though that is not entirely clear). The later Gabriel Manigault (1809-1888) was well-educated and well-traveled. His journal entries show that he was interested in theater, and very fond of literature. Despite the fact that he never owned White Oak Plantation, it is clear from his journal (Peter Manigault Collection 1840) that he at least helped manage it for some time, and likely did so after his father's death. Although several sources indicate that Arthur Middleton Manigault inherited White Oak Plantation in 1843, it seems more likely he did so in 1856 when records show him and a brother each buying halves of the plantation, presumably with their inheritance. Joseph's wife, Charlotte Drayton Manigault, outlived Joseph into the 1850s and may be the source of confusion.

Arthur served in the Mexican American war, and moved out to the Santee River sometime after his return. Gabriel probably helped manage the plantation until Arthur took over. Arthur was not as well educated as his brother, and instead had intended to go into the export trade before joining a militia company and starting what would be a successful military career. After Mexico he served in the Confederate Army, and had reached the rank of Brigadier General by the end of the Civil War (Peter Manigault Collection 1856a; Manigault 1983:IX-X). White Oak Plantation eventually passed to his son, Arthur M. Manigault II, who continued planting it for some time before permanently moving to Charleston to purchase *The News and Courier* newspaper in the early twentieth century. He gave *Bessie* to a friend who eventually donated it to the Charleston Museum, where it remains today (Charleston Museum 1926).

It is unclear how the White Oak Plantation came into the Manigault family, but it is likely that it was part of the nearly fifty thousand acres of land owned by the Gabriel Manigault of Revolutionary times. White Oak sat on the north bank of the North Santee River, and was flanked on either side by multiple other plantations. Ownership boundaries are not easily traced today, but records indicate that the plantation was located about a mile east of what is now the US Highway 17 bridge crossing the North Santee River. A map from 1873 suggests that most of the actual cultivatable land was on the delta separating the north and south forks of the Santee, but that the plantation house was on the north bank opposite these fields (Rogers 1970:291,296-297).⁴ In the early 1840s the plantation was owned by Joseph Manigault, though the sources

⁴ A map of several plantations found on the inside jacket of Alberta Morel Lachicotte, *Georgetown Rice Plantations* (1955) combined with an ordered list of plantations on the river bank found in Rogers (1970:291) suggest this location. An 1873 map (Peirce) confirms this general location though labels the fields on the delta to be White Oak, while the house is stated to be on the North bank by Rogers. A modern look at Google maps reveals that a small creek on the north bank near that spot is labeled "White Oak Creek." Appendix B shows reconstructed boundaries of White Oak plantation in a recent satellite view.

suggest that it was already treated as a family asset and used or managed by different family members. As already noted, the plantation was apparently subdivided in 1856 when Arthur Middleton Manigault purchased the eastern half and his brother Edward took possession of the west. Arthur's half was later inherited by his son (Peter Manigault Collection 1856a). The plantation left the family for good in 1912 when the younger Arthur sold it to the newly-formed Kinloch Gun Club, and it was later clumped into the nearby Rice Hope Plantation in a further sale in 1926 (Rogers 1970:493). *Bessie* appears to have followed the sale of the plantation land until donated to the Charleston Museum (Charleston Museum 1926).

Bessie is one of the only surviving examples of an authentic plantation boat, and currently resides in the courtyard of the museum. Of the variety of boats that were used on plantations in the nineteenth century, *Bessie* represents a very specific type not as easily named as some others. Flats, or a relatively large and basic vessel with a broad beam used to carry rice, were likely the most common boats on a plantation. There are also numerous instances of these being used for short transportation or to ferry carriages across water. Michael Alford (1992:198) notes that aspects of dugout construction may have been used in flat building, but they are a very distinct form of vessel from *Bessie* with an entirely different design.⁵ In 1843, Joseph Manigault's estate (which included more plantations than just White Oak) included four flats ranging in value (and thereby presumably size and quality) from \$5 to \$100 (Peter Manigault Collection 1843). Schooners are variable sized sailing ships with fore-and-aft rigs that were commonly used to transport rice from plantations to markets. Schooners were regularly contracted by the Manigault family, but again are entirely different forms of vessels from *Bessie*

⁵ An excellent painting of a rice flat can be found in Smith, Sass, and Smith (1936).

and will play no major role in this study.⁶ A third type of vessel in use in this era is a periagua (or perriauger, or pettiaguer, or any number of similar spellings). This term is far harder to define, and one questions if doing so has any particular historical value, but it was nevertheless considered a distinct vessel type.⁷ Periaguas may have been characterized by a building technique that involved multiple logs instead of one, but regardless of the exact definition during the period they were probably larger boats meant for cargo transport. In his description of the Carolinas in 1709, John Lawson commented (Vlach 1978:103) that some of these massive vessels carried up to a hundred barrels, and William C. Fleetwood (1995:103) notes that advertisements for periaguas listed many at over fifty feet in length, and eight-to-ten feet in beam.

In contrast to a schooner, flat, or periagua, this study will refer to *Bessie*-type vessels as either “boats,” “canoes,” “plantation boats” or “canoe boats,” and they will be the primary vessels of interest in this study. Lynn Harris does characterize *Bessie* as a periagua based on her taxonomy of vessel types (2014:70), but that term will not be used to refer to *Bessie* in this work. These terms are similar to those used throughout the Manigault records. “Canoe” is used at times to refer to smaller paddled vessels, but is also regularly used to describe large plantation boats. In this study the terms “canoe boats,” “boat canoes,” or “plantation boats” will be utilized to distinguish when referring to a larger vessel. These are best characterized in this work as long-and-narrow rowed or sailed vessels made out of one or more logs shaped into a boat. In the case of *Bessie*, a single massive cypress log was hollowed out to the desired form, at which point framing and structural timbers were added, as well as thwarts for sitting on. Eventually a

⁶ For references to schooner contracting, see Gabriel Manigault’s Journal (Peter Manigault Collection 1840:8 December 1840); a water color in Smith, Sass, and Smith (1936) also depicts a schooner loading.

⁷ For thoughts on the value of defining historical vessel types, see Maarleveld (1995).

centerboard and mast steps were added for sailing. The final dimensions of the craft are 8.98m long, 1.75m in beam, and 0.54m in depth of hold (Stewart et al. 2012:4).

The origins of this construction technique will be addressed in future chapters, but suffice it to say that Lynn Harris is probably correct in surmising that European, African, and Native American techniques all may have influenced the construction in one way or another.⁸ John Michael Vlach (1978:101) implies that *Bessie* may be atypical for plantation boats in its naval-launch-like shape, but his assertions are not supported by other scholars. Fleetwood (1995:111) discusses *Bessie*'s shape as entirely normal for the period, while Alford (1992:193-195) depicts numerous other examples from the era that look more like *Bessie* than what one would term a "canoe" today. Although it is a split-log vessel and has slightly different bow and stern shapes, the general hull form of the plantation boat *Accommodation* is also very similar to *Bessie* (Brown et al. 2011). *Bessie*'s estimated build date is 1855, but there are other possibilities that will be presented in the course of this chapter, and the general time period is of greater importance. Essentially, there is little reason to doubt that *Bessie* is a typical example of a plantation boat from the mid-nineteenth century, and thus constitutes an excellent case study for considering the culture that created and used it.

Boats and Slaves

The role that slaves played in the plantation boating world is both important and rather ambiguous. They were important as the builders of most plantation boats, they were the rowers, and they were sometimes even the captains of larger vessels. Essentially they played key roles in almost every aspect of boating. They were ambiguous as there is very little sign of them in the

⁸ For discussions of origin, see Vlach (1978) and Harris (1998; 2014).

primary sources; slaves are rarely mentioned outside of economic terms in the Manigault family records. Because there are so few direct references, their involvement must largely be inferred from other sources.

Slaves were primarily responsible for boat-building on large rice plantations. On November 5, 1840, Gabriel had just arrived on the Santee from his travels and notes that he “went to Ogilvies [another family plantation] with Mr. Blalock in my new canoe” (Peter Manigault Collection 1840). There is no mention of how he obtained said canoe, and only by the fact that he makes no comments about it while in Charleston one can surmise that it was not purchased there. Luckily, there is one more reference to a new canoe in the journal that is far more enlightening: on March 5, 1842 Gabriel simply (Peter Manigault Collection 1840) notes “making a canoe” after breakfast. This bare bones reference is followed in the next few weeks by the entries “laying out canoe,” “directing the carpenters on my boat,” “boat,” “building boat,” and “building boat” again. While the details are scanty, Gabriel is clearly building his new boat on the plantation, and does so with a crew of slave carpenters. It is impossible to say whether this boat was the *Bessie* as no specifics are given, but 1842 is a possible build year if the boat stayed with the plantation once Gabriel moved on.

Where exactly the knowledge necessary for building a dugout comes from is not immediately clear in the literature. As touched on above, the tradition could be based on African roots passed on through slavery; it could have been brought by the Huguenots or English settlers from Europe; or it could have been learned from Native Americans in the early days of colonization. Wherever the traditions originated, one must assume that the slaves were the possessors of this knowledge and skillset. Although Gabriel does say he directs them, there is nothing to suggest he has any experience in boat construction. His intermittent involvement in

building sequences suggests that he probably directed them in general needs or design but that he was not involved with the daily craftsmanship in a meaningful way.

The training for skilled slaves was normally by apprenticeship of some sort, and often accomplished in the city. The demand for skilled slaves had been high since the very beginnings of South Carolina slavery, and training occurred for several reasons (Wood 1974:42-43,197-199). At some points the extensive South Carolina lumber industry required more skilled labor than could be found in the white work force, and sawmills trained slaves instead (Eisterhold 1973:64-65). Many artisans were also willing to take on slave apprentices for a price, and masters would pay to have them learn skills so they could be hired out for higher prices. Some artisans even made a business of purchasing their own slaves that they could train and then resell elsewhere (Powers Jr. 1994:11). In general, slaves that showed intelligence or ability at a young age would often be selected for such careers. In addition to carpenters, there were slave shipwrights and boat-builders. These would undoubtedly have been less common, but slaves regularly worked in the maritime industries in Charleston and other cities (Newton 1977:37; Powers Jr. 1994:11). Both Frederick Douglass (2002:316) and Robert Smalls (Uya 1971:6-8), African Americans of later fame, worked as skilled laborers in shipyards during their years of bondage. Although these skills were often learned in the cities, young plantation slaves could certainly be trained by older plantation craftsmen as well. Peter Wood (1974:199) notes that skilled slaves were often moved around quite often, and generally transitioned easily between plantations and cities. William Byrne (1993:247-248) has detailed exactly what a skilled slave's life might look like by piecing together the history of "Woodson" the carpenter. He was initially trained to build railroad cars, but then sent to Savannah to be hired out. Eventually he was sent across Georgia to work on a plantation and broaden his carpentry skillset.

Slave carpenters were highly valued on plantations, and White Oak was no exception. The estate papers of Joseph Manigault (Peter Manigault Collection 1843) list “Joe Carpenter” and “Ben Carpenter” among his assets, each valued at \$700. The next highest value for any slave was \$500, and most were valued well below that. Carpenters also feature regularly in Gabriel’s journal (Peter Manigault Collection 1840:8 March 1841, 4 December 1841). He specifically discusses their work more than that of any other slaves, and in addition to boat-building he notes such projects as constructing harrows and making trunks. It seems that he liked to watch or supervise their work. The Manigault family generally thought very highly of their enslaved carpenters. A journal from Charlotte Drayton Manigault (wife of Joseph Manigault) (Peter Manigault Collection 1824:20 April 1852) describes her sorrow at the death of Mathias the carpenter: he was “certainly in our opinion, the best; & the most valuable as an example to his fellow servants – he was respected by both master and servant.” While there is no doubting that Gabriel valued the usefulness of carpenters, he also valued their opinions at times. One of his first acts upon arriving at White Oak was to speak to “Carpenter Mullhins” about the overseer during the previous year. The following day the overseer was told he would not be re-employed (Peter Manigault Collection 1840:8-9 November 1840). Carpenters were not just skilled, but were some of the most prominent and important slaves owned by the family. While the potential economic importance of boats will be discussed later on, the valuable resources assigned to their production speaks to their worth. If Gabriel was willing to regularly task his most valuable laborers with canoe-building for nearly a month, then a boat was clearly something he was willing to invest in.

The importance of slaves in construction was hardly their only involvement in boating; large canoe boats like *Bessie* were likely never operated without a slave crew in the antebellum

period. At no point in his journal does Gabriel mention the rowers that moved him around the North Santee River, except for one vague reference to getting angry with some “boat boys” (Peter Manigault Collection 1840:23 March 1841). He does very occasionally mention that he did row himself or others in some boats. These rare instances stand apart from the vast majority of references, implying that this was an unusual circumstance.⁹ Similarly, in a later journal, Gabriel does mention entering some kind of canoeing contest in which he gives exact dimensions for a significantly smaller canoe he did paddle, and then dimensions for a still smaller canoe that would have made paddling easier for him (Peter Manigault Collection 1856b:10 March 1858). It seems that he was not above paddling at times, but these times were anomalies.

The absence of any references to a slave crew in Gabriel’s journal (with the one exception of the boat boys) is not entirely surprising. Mentioning boating without mentioning the crew is no different from discussing rice production without ever mentioning the laborers. This is also quite common. When he does mention them, it is only vague references to “hands,” or “people.” In general, slaves are rarely seen in primary sources unless they are the direct subject of discussion. There are notable exceptions such as the carpenters and the occasional mention of punishment or illness, but only rarely does Gabriel discuss anyone outside the planter class, and he never does so with any specificity.

Other sources can shed light on what was normal at White Oak. From the earliest days of the colony, slaves who were familiar with boats were used for fishing, boating, or sailing to move goods and people around the waterways. They would be advertised as such when they were sold. Plantations would often have a “patroon” who would be in charge of the boats, and would train slaves to be rowers or crewmen (Wood 1974:202-203). Although there is no mention

⁹ For an example of his rowing himself in an outing from Charleston, see Gabriel’s Journal entry for October 5, 1841 (Peter Manigault Collection 1840).

of a patrol at White Oak, the presence of skillful watermen (or boat boys) must be assumed. Other sources from the nineteenth century discuss how plantation boats would be rowed by crews of slaves dressed in uniforms and hardened to rowing heavy boats several miles through choppy waters. Boating and rowing songs were common, some of which probably originated in African traditions but evolved into spirituals (Wood 1974:202; Fleetwood 1995:110-111). Reports from the time indicate that slave rowers were quite satisfied with their position and seemed content with their lives (Bell Jr. 1987:148), but such sources can hardly be considered trustworthy; there are few methods to discover what the slaves themselves thought during this period. While the absence of slaves from the White Oak sources leaves the bondsmen participants anonymous, their presence cannot be doubted. A canoe boat the size of *Bessie* could be sailed by a single person or a few individuals (the later modifications suggest that it eventually was), but the boat is far too large for a single person to row and features five asymmetrical oarlocks. It is safe to say that the slaves were an integral part of every aspect of plantation boating from the building of the vessel to its regular use.

Economic and Utilitarian Use of Plantation Boats

It has already been mentioned that plantations featured several different vessel types specifically designed for economic purposes, but one might question if there was an economic role for the *Bessie*-style boat as well. Additionally, one might assume these boats were a necessary form of transport to and from the plantation and the surrounding area. Fleetwood (1995:112) calls plantation boats the “cars and trucks” of plantation life, and implies that they fulfilled basic needs in a way that these vehicles do for us today. If the boats fulfilled a utilitarian role, their cultural significance might be diminished. On the other hand, if the boats were not

important for economic or transportation purposes, their presence on an 1840s plantation may be better explained by symbolic significance rather than utilitarian worth.

Although the cargo-carrying periaguas described by John Lawson are significantly larger than *Bessie*, Michael Alford (1992:193) suggests that a similarly sized split-log canoe might carry as many as 50 or 60 barrels. With roughly the same size and configuration as *Bessie*, Daniel Brown, Kathryn Cooper, and Lynn Harris concluded (2011:97) the split-log *Accommodation* would have been primarily used near the Sea Islands as a small cargo mover or utility vessel. The model of *Bessie* can better assess how much cargo such a plantation boat may have been able to carry, but Alford's estimate seems high considering the small amount of open space in the dugout once thwarts and frames are accounted for. One would also expect weight to be an issue with the five or six rowers that would be needed for propulsion (Stewart et al. 2012:25). Even if *Bessie*'s internal arrangement is atypical, it seems unlikely that a boat with *Bessie*'s dimensions could have hauled any large amount of cargo. More importantly, there is no record of similar boats doing so in Manigault family records. While Gabriel uses his boats for many different things, nowhere does he mention moving goods in them. He does routinely note the loading and unloading of flats or the scheduling of schooners to pick up the crop, but canoe-type vessels are never mentioned in these passages.

There are in fact only two references in Gabriel's journals to a small boat being used in support of the economic mission of the plantation. The first such occurrence was on January 29, 1841 when Gabriel (Peter Manigault Collection 1840) and some slaves used someone else's boat to attempt to string a wire across the river near the ferry. While this was not actual rice production, the boat was being used for a job to support the economic mission on the river. The second occurrence is in a later journal: in February of 1846 (Peter Manigault Collection 1845:12-

15 February 1846) strong winds hit just after a schooner loaded with rice was sent downriver and Gabriel feared that it might have gone aground. He rowed seven miles down the river to see that it was riding at anchor, and then rowed the seven miles back up against the wind. Again, the boat is only peripherally used to support the economic functions of the plantations, and in this case just as a form of transport. It is likely that the only major economic role for Manigault canoes in this period was to conveniently transport supervisors from place to place.

The transportation functions of plantation boats are more obvious, but still not entirely clear. In the colonial period, canoes were the backbone of transportation in coastal South Carolina, and slave boatmen would often be sent up river to trade with Native Americans, deliver mail, and serve as guides for white travelers in the region (Wood 1974:203). Canoes were still used for transportation in the nineteenth century, but there were other options as well. Fleetwood (1995:103-107,110) notes that some travelers preferred the canoe to overcrowded steamboats or schooners that relied on wind, and there was some allure to being whisked up and down creeks and rivers in hand-powered boats. He also notes that they could be slow, mosquito-infested, and very exposed to the elements at times. While the potential for canoe boats to be used for daily transportation in the 1840s is obvious, whether or not they were used this way is an entirely different question.

Although the sources are often rather vague, family records indicate that the Manigaults often used plantation boats for transportation, but did not rely on them. Charlotte Drayton (Peter Manigault Collection 1824:1 February 1853) describes a typical trip to White Oak from Charleston in her journal. It took a day and a half to make the journey, and she makes no mention of using a plantation boat along the way. Expecting visitors the following day, she sent a carriage from the plantation to nearby Georgetown to pick them up there. Gabriel elaborates

(Peter Manigault Collection 1840:18-19 November 1841) on that same route in his journal. On one of his return journeys from Charleston to White Oak, he notes that they left on one day, passed some friends on the road, and stayed the night at Awendaw, a spot roughly midway between the city and plantation. The following day they continued on to White Oak. They were likely mounted, or possibly in a carriage. They would have had to cross waterways at several points, but probably took the ferry. D. E. Huger Smith (Smith et al. 1936:59) recalls traveling to his plantation mostly by carriage, but then putting the carriage on a flat for the final trip up a canal.

Water crossings were inevitable no matter how a planter traveled from the city to the plantation, but there is no reason to think that the Manigaults used a plantation boat for this purpose. General transportation around the immediate area was probably regularly by boat, but not exclusively. Gabriel frequently traveled up and down the river to visit other plantations, but rarely specifies his means of travel. He does often mention riding in his daily excursions, and clearly boats were not the sole option. At one point he specifically notes that he went by water, implying that this was perhaps unusual.¹⁰ The use of carriages and horses demonstrate that White Oak was accessible by road, and even if boat travel was common it was but one of multiple options.

There is further evidence showing both the importance of boat travel and the availability of other options. The records of a lawsuit from 1898 (Peter Manigault Collection 1898) indicate that Arthur M. Manigault II and a neighbor sued another planter for using floodgates that made White Oak and Kinloch creeks unnavigable. The settlement specifies certain times of year when

¹⁰ For examples of him riding places rather than boating, see Gabriel's journal entries (Peter Manigault Collection 1840) between January 16 and 30, 1842. For a reference of traveling by water, see March 27 1841.

the gates can be used, and that if navigation ever becomes impossible the planter must guarantee alternate access across his land. The last stipulation implies that this was not an economic issue as land access would hardly allow for the transport of heavy crops otherwise done by flats. Even as late as 1898 water was thus an important means of transport.

The most dramatic reference to a plantation boat in Gabriel's journal occurs on March 20, 1841 (Peter Manigault Collection 1840) when his entry begins "Rose at 8. brkfst. My boat stolen last night." Although Gabriel does use boats after this point, several of them belonged to friends and others seem to be of a smaller sort. In general, there are fewer boating activities mentioned. This changes with the construction of his new boat in March of 1842, but one of his first uses of the vessel is racing it against the "green boat" (Peter Manigault Collection 1840:3 April 1842). It seems likely that Gabriel had access to this other "green" plantation boat all along (some of the few boating passages from this period also suggest this), but he nevertheless boated less frequently after his personal vessel was stolen. It is hard to say if the theft affected his everyday transportation since he rarely explains how he moved about, but as noted above there were certainly alternate modes of travel, and he survived without a personal boat for about a year.

While water transport was important on the plantation, it was neither the only means of travel nor even necessarily the preferred one. Gabriel's daily routine did not seem to vary tremendously after his boat was stolen except for his decline in using it. In other words, he still visited other plantations regularly and traveled about at will. He did occasionally go out in friends' boats and it is possible that he did use another plantation boat for his daily routine, but the loss of *his* boat was not particularly detrimental to his life. His building a new vessel demonstrates that he wanted to replace what he lost, but waiting a year is hardly indicative of necessity. Even if boats were important for transportation, Gabriel's personal boat was not. From

this we must assume that the plantation boat's ultimate purpose was not strictly utilitarian by the 1840's. Gabrielle survived without his personal vessel for a year, but nevertheless put a lot of energy and plantation resources into building a new one. His boat was important to him, and not just for getting around. This may have been less true for plantations in more isolated areas such as the Sea Islands further south, but for the Georgetown region plantation boats were not primarily working vessels.¹¹ To extend Fleetwood's analogy, if a plantation boat was similar to a car or truck in its everyday convenience, then it was also similar to a car in what it might mean to its owner beyond utilitarian value. Gabriel did not seem to need a new personal boat to go about his life, but he built one anyway. Car enthusiasts frequently purchase automobiles they do not strictly need. His boat probably served many important practical functions around the plantation, but that does not mean that this was its primary purpose or the sum of its value for Gabriel.

Plantation Recreation

Reading through Gabriel's journal, one is struck by the monotony of plantation life for planters (not to even address the life of slaves). In his short notations, one can see the same activities repeated again and again. Yet much of Gabriel's routine is recreational pursuits, and boating factors into these activities in various ways. Many of these undertakings had nothing to do with the water, but rowing about was something he enjoyed doing, and enjoyed combining with his other hobbies whenever possible.

The first thing a journal-reader learns about Gabriel is how well-read he is; he devoted a significant portion of his life to literary pursuits. Plans for future reading lists are common, and rarely does a day go by without some mention of what he is reading. One of his longest journal

¹¹ For some sense of boat use for transportation on Sea Island plantations, see Bell (1987:147-149).

entries is a full book review.¹² Although he read just about everywhere he went, it seemed that reading in his boat was a favored activity. Before his first boat was stolen, there are numerous references to his reading in it. Some of these seem to imply it is while he is traveling, but at other times he seems to have been idle: “reading Twelfth [sic] night in the boat. hands working on banks. returned mill overtook flat going to mill with rice: (Peter Manigault Collection 1840:22 December 1840). It is possible that he considered himself supervising in this reference, but whatever the circumstances Gabriel appears to have enjoyed reading Shakespeare in his boat to pass the time.

Hunting, fishing, and socializing with neighbors were also very important activities for Gabriel, and his boat was a regular if not critical part of all these activities. Gabriel always carried his gun, and rarely does more than a day pass without him shooting some fowl or other small game. Sometimes this seemed to be spontaneous, but there were also planned outings. Often these trips utilized his boat as a shooting platform (Peter Manigault Collection 1840:27 January 1841). Boats were much more important for fishing, and Gabriel mentions net fishing on several occasions. This was always done with neighbors or other family members, and one might question if he really enjoyed the sport; he frequently hunted alone, but seemed to fish only with company (Peter Manigault Collection 1840: 5 October 1841). In one instance, Gabriel went on an all-day fishing trip with various family members and servants from Charleston (Peter Manigault Collection 1840:8 April 1842). Boating was apparently a popular excursion from the city as well as the country. In another instance, Gabriel boated to a neighbor’s place where they took their own vessels to an island, fished together, then dined before returning home (Peter Manigault Collection 1840:27 February 1841). At other times they visited each other without

¹² See his review of Henry’s *History of Great Britain* (Peter Manigault Collection 1840:8 February 1841).

sporting, and boats were simply used to go for day trips with neighbors (Peter Manigault Collection 1840:21 March 1841). All of these activities (except fishing) occurred without boats at times, but they regularly occurred on the water as well.

Even the construction and maintenance of boats seemed to be recreational for Gabriel. When the carpenters built his second boat, he regularly attended and watched over the process (Peter Manigault Collection 1840:31 December 1840, 1 January 1841). He did the same when his first boat underwent maintenance and painting. Some passages even suggest that he helped with the maintenance, though that is impossible to say given the brevity of his notes (Peter Manigault Collection 1840:11-24 January 1841). He also spent time around his boats while they were out of the water but not actively being worked on. A few notes about reading in the boat may be from when it was still being painted, and he later records being “in my [new] boat with the girls” in the middle of the construction process (Peter Manigault Collection 1840:14 March 1842). Whatever state the boats were in, Gabriel clearly liked to be around them.

Sailing is another recreational activity that Gabriel was never particularly fond of, but Arthur certainly was. Arthur is rarely mentioned in Gabriel’s journal, but when he appears sailing is inevitably involved. The brothers only saw each other in Charleston during the period of the 1840-1842 journal, and one of their outings takes them to inspect and sail Arthur’s boat along with their brother Edward (Peter Manigault Collection 1840:17 September 1841). Gabriel did not enjoy it, noting that the wind was very strong and Arthur’s boat was quite wet. The family fishing excursion from Charleston also involved one of the two boats sailing, presumably with Arthur at the helm (Peter Manigault Collection 1840:6 October 1841). While both of these outings departed from Charleston rather than White Oak, the sailing features of *Bessie* indicate that sailing was practical on the North Santee as well (Stewart et al. 2012:13-17). *Bessie* features

a centerboard, as well as mast steps and partners necessary for supporting two masts. The Charleston Museum Accession Materials (1926) specify that Arthur Middleton Manigault added the centerboard later in *Bessie*'s life, but changes evident to the mast steps suggest that *Bessie* enjoyed a long sailing life and was very likely sailed by the earlier generation of Manigaults as well.

The boats themselves could also represent a form of recreational expression. Although *Bessie* appears as an unpainted vessel today, newspaper ads from the eighteenth century show that such boats were gaily decorated in various colors (Wood 1974:202-203). Gabriel never mentions how his boats were painted, but he does discuss the process for his first boat, and alludes to the nebulous "green boat" (Peter Manigault Collection 1840:11-24 January 1841, 3 April 1842). *Bessie*'s construction also shows evidence of the pride and care put into these vessels; the thwarts, mast partners, clamps, and rub rails all feature beaded edges that have limited practical purpose, but show the high level of craftsmanship put into the boat. Instances of racing support this idea of pride as well. Although the race with the green boat seems to have been a simple test of his new vessel, Gabriel was sure to jot down the capabilities of his original boat in comparison to that of his neighbor: "John Hume came in his boat. we went down the river in company. My boat can beat his, I think" (Peter Manigault Collection 1840:3 March 1841). Boat racing was an increasingly popular sport through the middle of the nineteenth century, and Fleetwood details its rise to prominence in the South. It began with plantation boats very similar to *Bessie* in Georgia, but quickly evolved to feature special-built dugouts that have more in common with modern racing sculls than canoes (Fleetwood 1995:113-121). There is no evidence that the *Bessie* or the Manigaults were ever involved in any formal racing, but Gabriel

was obviously proud that his craft could outperform that of his neighbor.¹³

While boats such as *Bessie* were useful for transportation and utilitarian duties in the development of South Carolina, it seems that by the 1840s they were probably more important as recreational vessels. Recreation at White Oak did not rely on the water, and there is plenty of evidence to suggest that other hobbies such as riding were actually much more common than boating. In one of her journals, Charlotte Drayton Manigault laments (Peter Manigault Collection 1824:2 March 1853) that inclement conditions had prevented her from riding more than twice in the four weeks she had been on the plantation. She does not mention boating. Nevertheless, venturing out on the river was important for Gabriel, and many of his hobbies involved boats in one way or another whether or not there was any practical reason for it. While Gabriel's personal boat does not appear critical for his day to day routine, he liked to make it a part of his life whenever possible. Though it was probably used for mundane purposes most of the time, there is no doubt that he took pride in his vessel, and likely the slaves who produced and crewed it for him as well.

Historical Conclusions

When examining the documentary record of White Oak Plantation, it is hard to overlook the importance of watercraft in every aspect of rice plantation management. Coastal South Carolina was a world full of waterways, and riverine culture ensured that plantation boats played a central role. The economic side of a rice plantation depended on the water, but societal interaction with the aquatic environment went far beyond practical use. Although the slaves

¹³ There is one reference in one of Gabriel's later journals (Peter Manigault Collection 1856b:10 March 1858) of what might be a canoe race, but the lack of detail leaves one unclear about whether it was a festive or competitive event, and the boat detailed is significantly smaller than *Bessie*.

remain a largely silent source, they were involved in boating culture at every level. Any sources that could reveal their attitude towards boating practices would go a long way towards understanding what these vessels meant to the entire plantation population; it would be fascinating to know what the builders and rowers thought about their vessel defeating that of their neighbor. For the planter, the boat was much more than a way to get around. Gabriel's interactions with his boats clearly show that he spent a good amount of time on the water, and enjoyed boating in various ways. The races and craftsmanship show the pride invested in these vessels, and the frequency of use clearly demonstrates their prominence in plantation life.

If the Old South plantation economy can be viewed as a system where the planter enjoyed the benefits of slavery with profits and social status, and demonstrated his power with a lifestyle of ease and outward shows of wealth, then plantation boats are the perfect representation of this system in rice-growing areas.¹⁴ In a water-bound world, boats would be an obvious way to display wealth, status, and lifestyle. A well-built logboat from this period could show the skill of the slave craftsmen that a planter possessed, the wealth needed to own a team of devoted rowers, and the freedom to pursue leisure activities in the most convenient and comfortable way possible. Gabriel Manigault could hardly be mistaken for a person of lesser status when being rowed down the river perusing his Shakespeare. On the contrary, everything about the vessel would convey the intended sense of aristocratic bearing, and still does convey the values of the society that created it. While there are some aspects of boating culture in this period that are still difficult to understand from sources, the importance of small boats in rice planter culture are unquestionable.

¹⁴ There are numerous books that have characterized Southern plantation economies in this way. For all the potential profits, slavery, and by extension the plantation system, was often more relevant for the social status it could bestow rather than the money. For some discussion of this, see Kenneth M. Stampp (1956).

CHAPTER 3: RECONSTRUCTION METHODOLOGY

Introduction

Recording a complex shape is difficult in any medium, and the nature of seagoing vessels makes them particularly challenging to represent accurately. All but the simplest boats have curved features for basic structural and hydrodynamic reasons, and when dealing with wooden boats virtually no surface is flat and no line is straight. Classical archaeological drawing techniques can be utilized for boats as with any other artifact, but the nature of shapes formed by complex curves in all three dimensions makes it especially difficult to depict boats in two-dimensional drawings. Even when recorded perfectly, making sense of such drawings can be difficult. Naval architecture has proved the efficacy of designing boats with three-dimensional drawings techniques, but artifact vessels are more difficult to understand when they are in poor condition, missing pieces, and frequently not in a position or setting where one can easily see or create body plans or half-breadths. The philosophy of using laser positioning technology such as total stations to record vessels is predicated on the idea that a researcher will be more successful in using a three-dimensional medium to record a complex three-dimensional shape than in trying to adapt the shape to two-dimensions. In other words, it is much easier to create and make sense of a three-dimensional model of a complex object than trying to understand the same object with two-dimensional drawings.

The data used and referenced here is for the plantation boat *Bessie*, which was recorded by a team of student-archaeologists from East Carolina University during a field school in 2010. The author received the data set generated by the field school, and had no part in the collection process. In using this data set to create a reconstruction, this project will be testing the feasibility

of this recording practice for future fieldwork. Field schools are often useful (or necessary) forms of fieldwork, and so the likelihood of using a similar opportunity for a future project is very high. The distance between the fieldwork and the reconstructor make this an ideal test since the reconstruction will be almost entirely reliant on the data generated in 2010. The author has visited the Charleston museum for additional observations, notes, and photographs several times in the intervening years, but these trips have in no way altered or supplemented the original total station data. Again, this is a likely scenario for future work of this nature when the cost and time involved in fieldwork often make repeat trips impossible. Although the author was not present for the fieldwork, the procedures described in this chapter were derived from several other field projects that used the same equipment to create similar data sets for comparable projects.

This chapter will explore the process and challenges of this recording technique. The first section will discuss the process of recording a vessel or object with a total station, and then describe how the point cloud is manipulated and used to create the reconstruction. Whereas this entire reconstruction is far too complex to describe in great detail, the process, notes and results will be shown for a representative piece. This chapter will primarily focus on methodology; the importance of the model for understanding *Bessie* will be discussed in future chapters.

Total Station Recording

Recording digital point data with a total station is best accomplished with a team of three people working in unison. Whereas it only takes one person to actually manipulate the total station, the data is effectively worthless if it is not recorded in conjunction with written notes and drawings. The team consists of a total station operator, a recorder (or cataloger), and a pointer (or spotter).

Before the total station is used at all, there is plenty of traditional archaeological recording that is necessary for this process. Sketches should be made of the entire site, and specific details noted for future reference. Construction diagrams are essential for understanding how exactly pieces go together in the reconstruction process, and pictures are required for checking accuracy and examining shapes and details that are difficult to record with a total station. Measured drawings are also essential in the reconstruction process even with the total station data, so one set of drawings should be dedicated to measurements of timbers and spacing while a second set should be left blank to assist with the total station recording. In this respect, total station technology is not a replacement for standard archaeological field practices, but more of an additional tool to be used for digital reconstruction and three-dimensional recording. The advantage of using a total station is that it records objects in their native three-dimensions, but the traditional two-dimensional data is crucial for understanding and processing the point cloud after the field work is complete.

The equipment used for the *Bessie* fieldwork included a Topcon GPT-3002 LW total station linked to a Topcon FC 2500 data recorder. Any standard total station can do similar work, but it is highly recommended to use a reflector-less station that can be aimed at any surface rather than just reflectors or prisms. A data recorder is not strictly necessary, as the total station point details can be hand recorded as they are shot, but this is unfeasible for a project of this magnitude. With this equipment, the total station sends each point to the data recorder, which catalogs them with consecutively-numbered prefixed labels that can be programmed in advance or as the recording progresses. The data recorder can also be set up so that each point is cataloged within a layer, or grouping of points, so that they can be easily identified when exported. After the project, the data will be downloaded to a Microsoft Excel document where

each point coordinate will be labeled with its prefixed-numbered identity. This Point Catalog is critical for modeling since the points will not display their identity within most versions of Rhinoceros, but are identifiable when their coordinates are cross-referenced with the catalog. Although the points will not retain their individual labels in Rhinoceros, they can be imported into the layers and groupings that were set up in the data recorder. As with every phase of this type of project, sufficient preparation is essential for understanding and processing the data later.

The first step involving the total station is planning. Total stations are extremely versatile, but they do have a limited range of vertical motion, a minimum range of about three to five feet, and the machine must be able to see predetermined datums from any deployment site in order to locate itself relative to existing data. Evaluating a site involves finding the best shooting locations to gather as much data as possible without moving the station. Once likely positions have been identified, datums need to be chosen that can be seen from as many shooting locations as possible. Generally the first deployment of the station involves shooting a number of marked datums that can be easily targeted from different parts of the site. Once these have been established the station can be moved, or resectioned, and shooting can continue within the same cloud of points as long as it can target three distinct datums at widely different angles to establish its own location. Resectioning is a time consuming process, and an efficient team will use the fewest shooting locations necessary to complete the data set. Two datums are sufficient to establish a new total station location, but the third will check the error of the setup ensuring that the station is properly sited. Any previously recorded points can be used as datums, but creating specifically marked points is best to ensure consistency, and they can always be added later from different sites to allow resectioning further and further from the initial deployment. Once this initial groundwork has been laid, the actual recording can commence.

The total station operator has the simplest job. They manipulate the station to aim at each point, and fine tune the instrument to ensure that the laser is properly focused at a solid object that will result in an accurate recording. This involves pointing the station into the general area of the point, using first general and then fine-tuning knobs to target the point through the crosshairs, and then locking the two axes in place before taking the measurement. The operator must double check that the correct label is applied to each point by the total station and accompanying data recorder. The East Carolina University Program in Maritime Studies uses a series of letters followed by sequential numbers to identify different points based on where the datum is located. For example, point SBFU7014 would be the 14th point recorded on the 7th futtock on the starboard side; MSMP004 would be the 4th point on the mast partner located amidships; BBKN4002 would be the second point recorded on the 4th knee on the port side, and so on.¹⁵ As noted above, these labels are set up in the data recorder, and then points are sequentially labeled. When the total station is properly focused and the label is checked, the operator simply pushes a button on the data recorder in order to fire the laser and record the point. The operator will simultaneously announce the point's label to ensure the entire team is recording the data accurately. A successful measurement is identified by an accompanying sound effect, and the team moves to the next point.

Each time a point is measured, the recorder is responsible for noting its location on accompanying sketches of the object being recorded. A point cloud can be indecipherable when first imported into a three-dimensional modeling program, and the recorder ensures that the modeler has enough context to accurately assemble the points into shapes. The recorder will thus

¹⁵ BB stands for Babord, which is Swedish for port side and is used to maintain convention with recording techniques developed by Dan Zwick at the *Vasa* Museum in Sweden in 2009, and further refined by ECU students and museum staff later that year.

position himself or herself off to the side of the recorder and pointer, and will utilize the previously made sketches of the area being recorded. It is especially important that they annotate identifying features or irregularities such as breaks, fasteners, or shaping unique to that particular object. For each desired point, the recorder will draw a small hollow triangle on the sketch with one corner touching the spot to be recorded. When an accurate measurement is taken, the triangle is filled in and the point label is written by the triangle. Triangles left hollow can be used to show points that could not be seen or shot from that total station location, but that would be helpful to take from a different angle later if possible. Any given area can require one broad sketch or several diagrams of different pieces from different angles depending on the complexity of the part or shape. A finished sketch will show the labeled object with labeled points drawn in relation to annotated identifying marks or features.

The pointer can have the most difficult job in some ways. While the shooter is responsible for getting all the points they think necessary to record the object, the pointer often is able to see or feel details up close that warrant recording and sometimes ends up driving the operation. It is necessary that both the shooter and pointer are communicating which areas require points from their unique perspectives to achieve an ideal point cloud. While more points are generally better, too many can create problems. For example, lots of points on a simple arc might confuse the modeling program into creating a wavy curve to accommodate slight errors in some points. Fewer points (even with the same error) will allow a smoother curve that is ultimately more accurate to the original. Too few points will obviously give the modeler insufficient data, but the fewer points needed the faster the team can move. The pointer must also identify what small classifying features need to be specifically noted and recorded and must communicate this with the recorder. When the pointer has identified the next point, he or she will

use the end of a wand or stick to help the operator target the correct location. If an older total station is being used the pointer may need to actually hold a small reflector or prism with a target over the desired spot, but a reflector-less total station is recommended for efficient work. The pointer is also responsible for helping ensure the laser hits the proper target. When the point is on a corner or edge, it is very easy for the station to take a false length measurement if the laser misses over the edge of the target and hits a surface behind the location. The pointer will thus place the wand or another surface behind the edge or against it to backstop the target, and ensure that if the laser misses the target it will hit a surface the same distance away and record the proper length measurement regardless. The pointer has very little part in recording actual data, but has the most important archaeological job in deciding what is necessary to record.

An experienced team recording with these techniques can record several hundred points in an afternoon. Recording an entire vessel can take a long time, although complexity is far more relevant than size in the recording process. A medium-sized vessel with simple lines and few construction elements might be recorded in an afternoon with a few hundred points, while a small launch with intricately carved woodwork might take weeks and several thousand points to recreate accurately. The goal of the recording is also pertinent as a total station is an ideal instrument to take the lines of a vessel, and this can be done with minimal planning and time when compared to full reconstruction projects. As with any exercise, the team will increase their efficiency and precision as they work together and determine how best to communicate in their effort.

Modeling in Rhinoceros

The next step is to import the digital point cloud into a three-dimensional modeling

program, and begin to recreate the vessel one shape at a time. This project uses Rhinoceros, which is user-friendly modeling software that uses non-uniform rational basis spline (or NURBS) algorithms to form smooth curves and shapes that work well to represent ship curves. This has been a standard software choice for projects of this nature undertaken by faculty and students at East Carolina University, but there are other options as well, and the point cloud could easily be loaded into virtually any three-dimensional modeling software.

When first imported, the point cloud can be relatively overwhelming if it has not been properly planned in advance. *Bessie's* point cloud is a relatively modest 1255 points, but before specific pieces are highlighted or defined it can look more like a blob than a vessel. One of the first things to do is take advantage of the software, and orient the vessel along the provided axes within the three-dimensional plane. This might require some sorting of points (described below) to first identify diagnostic features such as the stem and stern, but is worth doing as quickly as possible. This will make viewing the boat significantly easier, and immediately allow the reconstructor to start using the various viewing fields in the best possible way. The default view in Rhinoceros shows the data cloud in four viewing panes simultaneously: Top, Back, Side, and Perspective. Once the points are properly oriented, the first pane will be a plan view and the second and third will be elevations. The Perspective viewport is a three-dimensional pane where the working area can be rotated and manipulated with the cursor. It is the least useful pane for modeling since drawing cohesively into a three-dimensional field is virtually impossible, but is extremely important for keeping everything organized while modeling in the other panes. Any of the four can be enlarged at any time, or minimized as necessary.

Orienting the point cloud to view-friendly axes is simple in Rhinoceros, but can invalidate the point catalog created by the data recorder. To prevent this from happening, the

point catalog can be modified along with the point cloud to allow re-orientation without losing the ability to identify points by referencing the catalog. This is somewhat complicated. If the entire point cloud is moved or rotated within a single viewing pane of Rhinoceros, two of the three coordinates might change, but one will remain the same. For example, if the point cloud is rotated in the top view pane, then the x and z coordinates for most points will change, but the y coordinate will remain the same. To correct the coordinates in the point catalog, simply export the new coordinates into a separate excel document, sort both sets of point coordinates by the unchanged y value, and then copy and paste the new x and z values into the original Point Catalog that retains the labels. Once this is complete for the top view, the same process can be repeated with the front or side view to align the point cloud in the y axis. Manipulating the Point Catalog to reorient the point cloud is not strictly necessary, but worth the effort. It need only be done once, and allows the modeler to orient the vessel in a logical fashion to simplify modeling. Changing the Point Catalog to match the reorientation is essential for ensuring the points can be identified when necessary. A simpler method is simply to label all points within Rhinoceros before manipulating the orientation of the point cloud. This makes modeling considerably easier, but can be a hassle depending on the number of points in the cloud.

The next step is making sense of the points, and organizing them into different layers. If the points were recorded in layers within the data recorder, then the software can import these. If not, you may need to identify each point manually (see below) and then assign them into a proper layer. Hiding layers is essential to simplifying the data, and focusing in on just the aspects being used at any given time. Once the broad layers are defined, each can be sorted more specifically. For example, while one layer used during recording was thwarts, it can be further simplified by creating sublayers for each individual thwart. In some cases this is straightforward

when groups of points can easily be identified in relation to each other or other groups, but in some cases it is best to wait until working on that particular section when individual points will need to be identified anyway. Regardless of when it occurs, this sorting is crucial for making the model understandable and easier to work on. Layer control can help organize every aspect of the reconstruction process, and allows the modeler to easily return to previous work without having too many distractions visible. The value of sublayers will be discussed in greater detail as relevant.

The actual modeling starts with a single piece. It is important to start with a well-defined piece that does not necessarily rely on others for its shape or location. If each piece was recorded perfectly it would not matter, but if the precise location of a part butts up against another, then you need to consider which is best to model first. The hull is an ideal piece in this case since it defines the shape of each piece within it; this will be discussed further in reference to *Bessie* in future chapters. Once the starting point is identified, you can isolate it using layers. Typically the author would turn off all layers and sublayers excepting the one being worked on to obtain the best views and angles for reconstruction. It can however be useful to leave some out-of-the-way points on as a reference to help orient the piece within the vessel. The author did virtually all modeling with the breasthook layer visible so that the bow and orientation of the vessel were always immediately identifiable. Once the target piece is isolated in a layer, it is useful to find all the relevant data recorded for that piece. Typically this is going to include any photographs of the piece, any measured drawings of the piece, annotated drawings showing the point locations on the piece, and finally the point catalog generated by the total station. With these tools, it is a simple matter to connect the dots with straight curves (curves being any line within the software) to form a rough shape. It is useful to create yet another sublayer for each individual piece labeled

“construction” to distinguish the recorded data from anything created for the model. Separating field data and construction lines into separate sublayers makes it easy to go back and reference recorded data, and differentiate that from anything reconstructed. This is also necessary for starting over when reconstruction attempts fail. Incremental saves are also useful for ensuring that failed attempts are easily undone by reverting to a previous version of the model. Keeping an untouched copy of the file with only raw data also ensures the original recorded information is always retrievable when necessary.

Sometimes building a rough wireframe shape is as easy as connect-the-dots when points are quickly identifiable, but sometimes it is impossible to decipher which point is which without the point catalog. In this case, one can select a relatively unique point (generally a corner or something on the edge of the shape) and use the point detail function to see the x, y, and z values for the point’s location within the three-dimensional grid. These values can be cross-referenced with the point catalog to identify the name of the point, which can then be located on the appropriate annotated drawing. Once several points within Rhinoceros have been identified, they can be connected in a coherent fashion. Sometimes it is necessary to use points from other sublayers that represent connections or joints, and have been labeled for the other part. Eventually a rough outline of the shape is formed with straight lines. As is necessary at virtually every step, it is worth pausing here to ensure that the shape at least generally matches what photos and drawings show.

With the rough outline, it should be relatively clear what data is missing from the point cloud. There will often be laser shots that missed their intended target, or edges which could not be seen from any shooting location. These areas will need to be addressed with either points on other layers, the measured drawings, or in some cases just with photos. This is still a planning

phase in some ways as every shape will require a different strategy and different tools to model.

The goal for this step is to create a digital wireframe that accurately represents the shape.

Rhinoceros offers a variety of tools that can be swapped out as needed. For example, sometimes a simple straight curve is ideal for a line connecting two corners of a straight edge. However, if there is a bow or arc to the shape, then there are a variety of curves that might fit best. Two of the most common commands used are “Interpolate Points” and “Curve through Points.” This section is not intended to be a manual for Rhinoceros, but suffice to say that each command generates a curve with a different algorithm, and therefore can produce slightly different results depending on the relative positions of the points. Sometimes multiple curves need to be tried to see what fits the data best and creates a shape most similar to the original. It can be necessary to add points to the shape in order to better create a curve, or fill in missing sections from drawings or photos. Adding points is relatively easy, but these should not be mixed with actual data and should be segregated to the construction sublayer so as not to be confused later. Mastering tools in Rhinoceros such as layers, various command prompts, and snaps (which align the cursor to set points, ends of curves, gridlines, or other notable spots) make this most difficult step more manageable.

It should be noted at this point that the data can be flawed, and frequently is in the case of *Bessie*. While the intent of this technique is to precisely record in three-dimensions, there are times when data is noticeably different from photos or drawings. Sometimes shots are obvious misses, and will appear far from their intended target. These must generally be ignored. If the cause of the error can be identified, sometimes it is possible to recreate where the point should be with other data. More often, points are in the generally correct area, but can be identified as incorrect for one reason or another. Most of the time this occurs when points are meant to form a

clear shape, such as a nearly right angle, a close-to straight line, or a circular cutout, but do not do so. This is normally evident when comparing the point cloud to photos. In these cases, the reconstructor must decide which points to alter or discard, and how to use the remaining data to best model the shape as accurately as possible. A reconstruction is inherently different from an original and so the author has found that this is frequently necessary, but every such decision must be justifiable and decision-making should be consistent throughout the modeling process. A modeling log can be useful to track these changes for future reference or justification, specify what modeling techniques were chosen for each individual piece, and discuss why choices were made that involved altering the original data set. The unedited modeling log for this project is reproduced as Appendix C.

One useful command for making corrections is the “Nudge” feature, which allows one to move a point very minute distances along any axis. If there are identifiable flaws in the data, this can help correct them in a single dimension without altering other aspects of the point. For example, if the edge of a futtock should be relatively straight when viewed from above (based on pictures and observations), a point can be nudged into line in that dimension without altering the location of the point from a front view. Altering a point like this is potentially ignoring valuable data concerning the authentic shape of some pieces, but is frequently necessary to create a model with any resemblance to the original. In the interest of preserving the original data set, the author always created a duplicate point within the construction sublayer that was manipulated rather than irreversibly altering the original.

With a completed wireframe depicting the individual timber as accurately as possible, the next step is to create surfaces. Similarly to curves, there are numerous surfacing tools that are best utilized in different situations. For example, the “Surface from a Network of Curves” tool

can be best for a wavy shape, but might not be as effective if there are not curves running through the middle of an area. The “Sweep 2 Rails” surface is one of the most useful for longer shapes that run roughly parallel, but requires a fairly specific set of curves to work properly. The “Patch” command is an extremely important fallback for areas impossible to surface with other tools, but the edges are not always as accurate to the curves being patched. Each element has unique shapes that will require different surfacing techniques, and often a series of different commands must be tried and then combined to accurately surface a single piece. After each step, it is worth pausing to compare the model with photos and drawings to ensure obvious errors have not manifested from reconstruction decisions. The surfaces are sometimes better viewed with different filters enabled in the viewing pane, and preview rendering can be useful to see unintended imperfections.

The final step for constructing a basic single piece is to convert the surfaced wireframe into a solid object. In some cases this is as simple as using the “Create Solid” command and just selecting each individual surface, but sometimes this command will fail if the surface edges do not align within the tolerances of the command. When this occurs, it can require identifying abnormalities in the data, resurfacing certain sections with different techniques or tools, or in some cases manually stitching the edges of surfaces together. This can be done by using the “Join 2 Naked Edges” tool to manually interlock all surface edges to each other. While effective, it does move surface edges to align with each other, and thus introduces another source of error if edges are moved away from the original points. Note that solids can sometimes be formed with direct commands such as “Extrude Surface” to create basic shapes with less construction, but this is rarely possible when working with a data set rather than just an end shape in mind.

Once the basic shape is accurately formed, it can be modified with advanced techniques

to add details and notable features missing from the general outline. For example, it is difficult to model a network of surfaces with a hole through them, but is simple to create the basic shape and then add the hole later. Once the solid is constructed one can create a separate solid cylinder that extends through the shape on both sides where the hole is located, and then create the negative space using a “Boolean Split” command. Modifications of this same technique can be used to alter edges, create damage or repair sections, or even beadwork and details that would be impossible to model in the basic shape. Edges can also be filleted, chamfered, or blended as needed to match the original design of the piece or reflect any wear that has occurred. The modeling process is a constant puzzle requiring the use of different tools and techniques in creative ways to best match the data set.

Once the piece is complete, the reconstructor can move on to the next and build the entire vessel piece by piece. The interlocking nature of construction elements requires the constant checking of each new construction against those around it to ensure they fit properly. When pieces overlap, it can be necessary to determine which piece is larger than intended, and then trim it to size. When interlocking pieces are too small, it can mean entirely redesigning one of them to fit properly against the other. This constant back and forth ensures that no piece is ever really done until everything around it is completed, which requires everything around it, which inevitably means that anything can require reevaluation until the entire model is complete. The final steps in modeling can be adding particular features or details to personify the vessel as well as possible. The surfaces can be textured with generic graphics for different woods or materials, or photos of wood grain from the vessel itself. A finished model can also be manipulated in further ways depending on its intended use. Add-on programs such as Orca 3D can be used to apply principles of naval architecture to the vessel, or animation software can help aid in

demonstrating the construction process. Some of these techniques will be further discussed in Chapter 4.

Modeling a Knee

Knees are some of the more complex individual shapes within *Bessie*'s structure, and the process of modeling one demonstrates many of the different techniques that go into creating a vessel in Rhinoceros. This section will go step by step through the process of modeling the port side standing knee that rests on thwart 1. This knee is fairly representative of how every piece was approached throughout the modeling process. Figure 2 shows the point cloud for the Thwart 1 Knees.

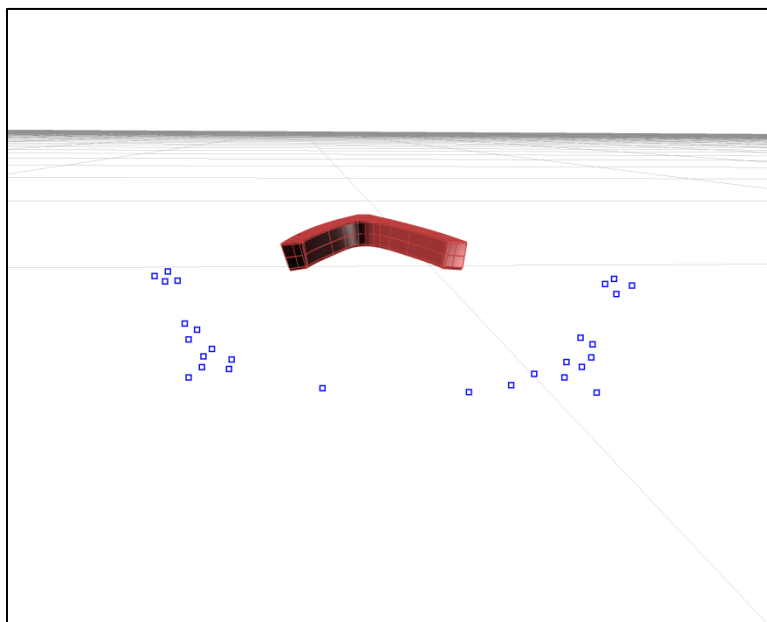

Figure 2: Point Cloud for Thwart 1 Knees

The points are shown in the perspective view, with the breasthook also visible in red for reference. The data points have been isolated within a layer labeled “Knees,” and then further isolated in a sublayer labeled “Thwart 1 Knees,” which separates it from each other set of knees. Within the “Thwart 1 Knees” layer are three sublayers labeled “Thwart 1 Knees Points,”

“Thwart 1 Knees Construction,” and “Thwart 1 Knees Solid.” The points layer will only ever have the original data, will not be modified in any way, and show as blue in Figure 2 and each consecutive figure. The construction layer houses all the different points, curves, and surfaces that are used throughout the modeling process (for complex pieces this is sometimes broken down into further layers) and will show in black. The solid layer also shows as blue and only houses the finished product so that it can be easily isolated from the multitude of points, curves, and surfaces used to build it.

As outlined above, the first step in attempting to model this piece is to identify the points by comparing them to the point catalog and annotated drawings, and then piecing together a rough shape that can be refined. Figure 3 shows the annotated drawings for the Thwart 1 Knees.

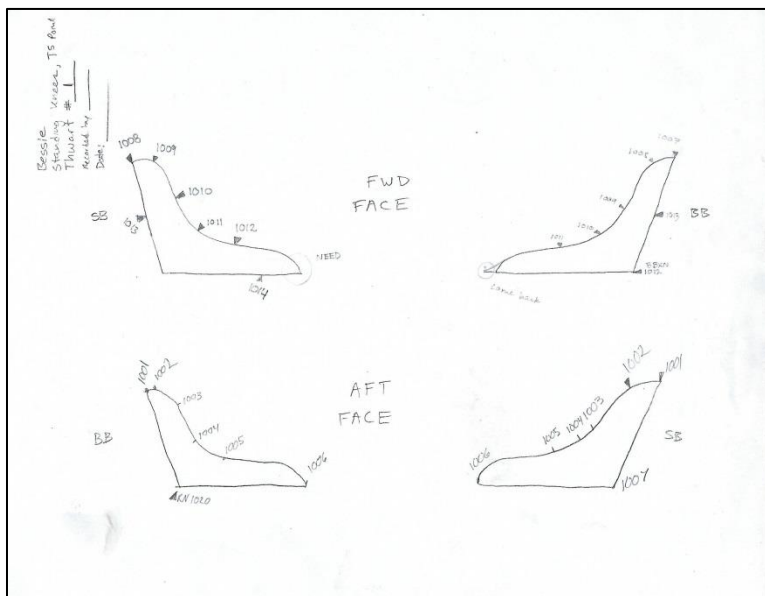

Figure 3: Annotated Drawings with Point Locations for Thwart 1 Knees

When manipulated in the perspective view, the various points can be compared to the drawings and identified fairly easily. There are no obvious missed points on either knee, though there are clearly areas with no points that will have to be reconstructed from the measured drawings.

Using the identity of the points, straight curves were used to create the rough wireframe shown

in Figure 4.

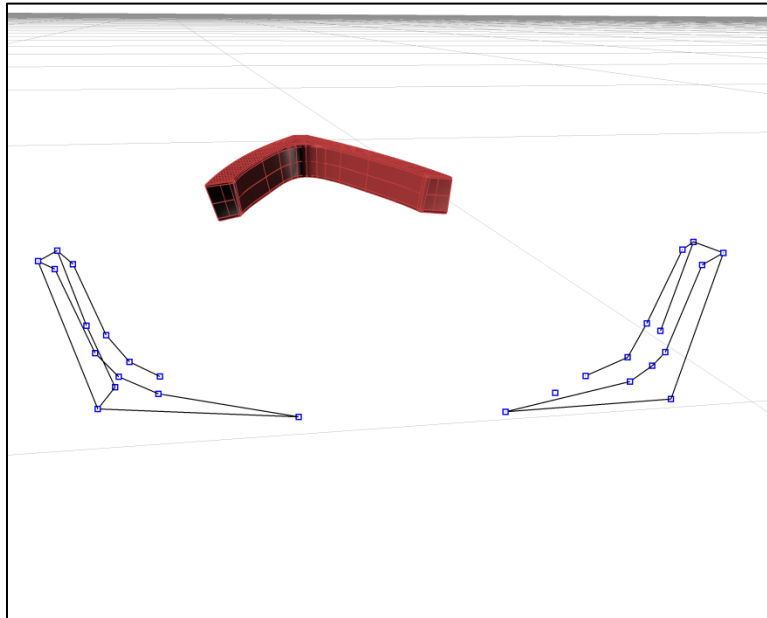

Figure 4: Rough Wireframe Construction for Thwart 1 Knees

This section will be focusing on the port knee, and so the primary area needing attention was the inboard edge where only a single point, BBKN1006 (as can be seen in Figures 3 and 4), marks the length of the knee. There is no total station data for the forward, inboard, corner of the knee, nor to mark the thickness of the piece on the inboard edge. The lack of points means that measured drawings and photographs were necessary to rebuild that particular section. In this case, there are photos available for both Thwart 1 Knees, but few measured drawings. There are no measurements that show either the width or thickness of the port knee on the inboard edge. Photographs show the knee to be very comparable to the knees on thwart 2 if slightly wider, and so those measures were substituted in this case. The inboard edge of the port knee was modeled .04 meters wide – slightly wider than the .035 m and .039 m measurements for thwart 2 knees, and as accurate to the photographs as possible. No thickness was measured for the inboard edge of either knee on thwart 1, so the same method of using other measurements and photos was used to create points for the upper corner of the inboard edge, which appears to be fairly blunted.

These added points helped complete the rough wireframe shown in Figure 5. Note that created points are shown in black to distinguish from the blue total station data.

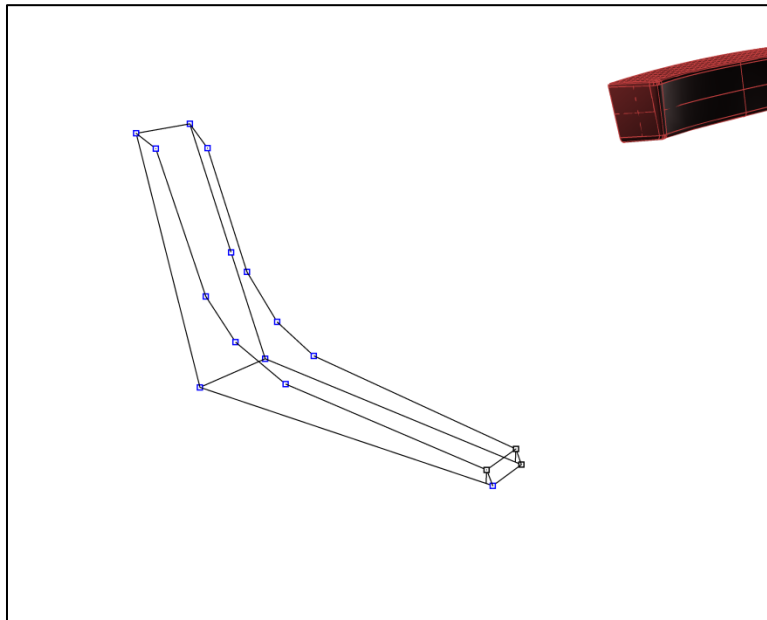

Figure 5: Completed Rough Wireframe for Port Thwart 1 Knee

With the wireframe complete, real curves can replace the straight placeholders to recreate the actual shape of the timber. Each curve is recreated separately, but is often best represented with the command “Interpolate through Points.” This creates a line that will pass through any and all points designated along its path, but tries to do so in as smooth an arc as possible. Even then, the command creates some shapes that are obviously undesirable. There are three good ways to address this. One way is to model extreme segments of the curve separately, and then join them together. Another is to add additional points to help control the curve where it would otherwise assume a shape that does not exist. A curve can also be drawn through the original points, and then the shape of that curve can be manipulated and edited to better match the actual shape. Each of these methods works better at different times. Figure 6 shows how a combination of these strategies was used to best model the lines in this case. The red lines were curves made with only the original data, while the black lines were made with multiple curves and additional

(black) control points added. The black lines are virtually identical through the areas with good data, but match the reality of the shape much better at each end where the points were added. Note that the forward edge also shows a slight discrepancy near the middle of the curve where a black point was added to replace BBKN1010 and nudged slightly aft to create a smoother line that better matches photos. Any nudging of original data points is dangerous, but often they create unwanted shapes when left untouched.

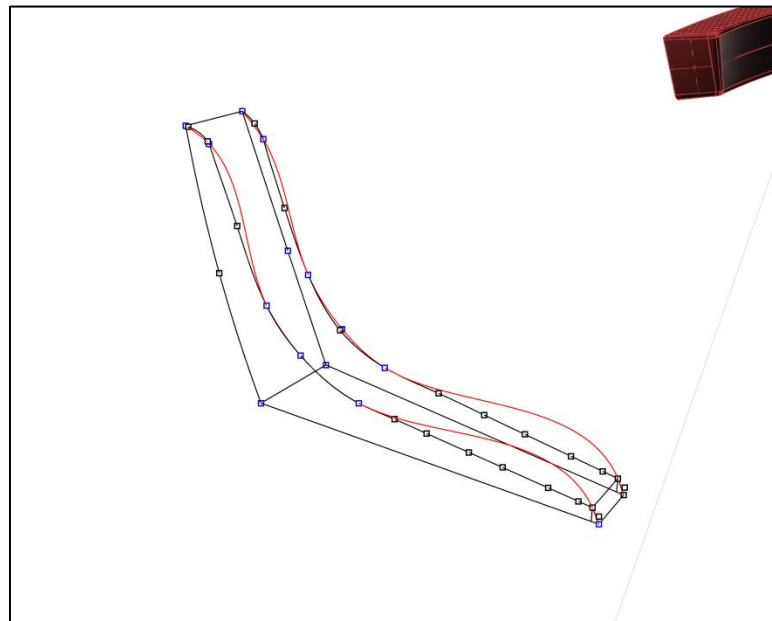

Figure 6: Port Thwart 1 Knee with Simple Curves (red) and Controlled Curves (black)

In this case, the decision was made that this one point was creating an unrealistic bulge in the curve. Nudging it slightly corrected this abnormality that is not seen in photos or other points. Figure 6 also shows some slight additions and changes to the outboard edges; the forward outboard edge were modeled with a curve through the points, and the aft outboard edge was made to match by adding a point near the middle to help accommodate the curvature of the hull where no points were captured.

The next step is surfacing, and this was done mostly with the command “Sweep 2 Rails.” There are fourteen different surfacing tools, and a combination of these is best utilized to recreate

each individual surface depending on what curves and points are available and what shape they will make. Rail sweeps are perfect for longer relatively parallel lines, and these were used for each section of the port knee excepting the forward and aft faces. These faces are complex and relatively triangular in shape, and the “Patch” command ended up being best for these. The patch command is not as precise around the edges as some other surfacing tools, but is sometimes the only option for the shape. Figure 7 shows the completed wireframe with the surfaces in place.

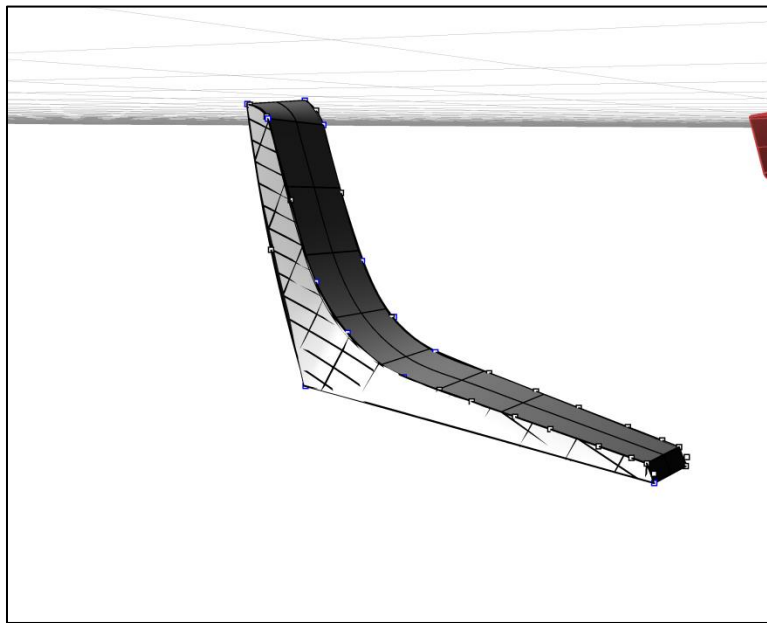

Figure 7: Port Thwart 1 Knee with Basic Surfaces Applied to the Wireframe

As noted above, the “Create Solid” command does not work for every combination of surfaces. In this case, the patched surfaces did not create edges precise enough for the command, and each pair of edges had to be manually connected with the “Join 2 Naked Edges” tool. This is never ideal for accuracy, but in this case the tolerances were very low and the shape came together quite nicely. Selecting each edge from the rail sweep surface first helped to pull the patch edge closer to the more accurate edge (the one formed with the better surfacing tool). A close comparison of the connecting surfaces to the wireframe shows that this was successful in keeping the form true to the intended shape. In this case there was no need to remake the

surfaces or even the curves that created them, but even the joining edge tool often requires going back to rework at least some of the component parts that create the solid shape. The final solid in this case was ready for detailing and final adjustments to match the timber as closely as possible.

In the case of the port knee on Thwart 1, the inboard edges have all been rounded off, and so they were filleted to match the original wood. The fillet command allows one to select the edge of a solid to round off, and then select the radius of the curvature for the fillet. If the command works properly, it will create a rounded surface to replace the hard edge, and then cut and stitch each surface back together to recreate the solid. Sometimes complex edges prevent this from happening, and either the edge needs to be reworked slightly (particularly the ends where the new fillet surface has trouble creating new clean edges) or the radius on one or both edges can be adjusted to make the fillet command work more effectively with the shape as is. As with many commands in Rhinoceros, sometimes simple measures like switching the order in which command parameters are selected (different points, edges, surfaces, and so on) can affect the efficacy of the tool. In extreme cases, the automatic aspects of the command can fail, and creating a filleted edge for some pieces can require exploding the old solid into different surfaces, and then manually trimming each old surface to align with the new fillet surface, and then stitching the edges back together. This was not necessary for the port Thwart 1 Knee, where edges filleted properly with a radius of .01 m.

Figure 8 shows the final solid for this port knee in blue surrounded by the various construction elements in close proximity to it. The location of this knee mostly lines up correctly, but there was some overlap with Thwart 1. After examining the original points for the knee, the thwart, and the various pieces that interact with the thwart, reshaping Thwart 1 to sag slightly in the middle seemed to be the best solution to remove the overlap and ensure the knee, thwart,

mast partner, and futtocks all still matched their original recorded locations as nearly as possible. This was accomplished by creating a new sagging curve, and then using the “Flow Along Curve” command to bend the thwart to match. One quickly finds that through error of one sort or another, it is often necessary to invalidate some total station points with the recorded location of others.

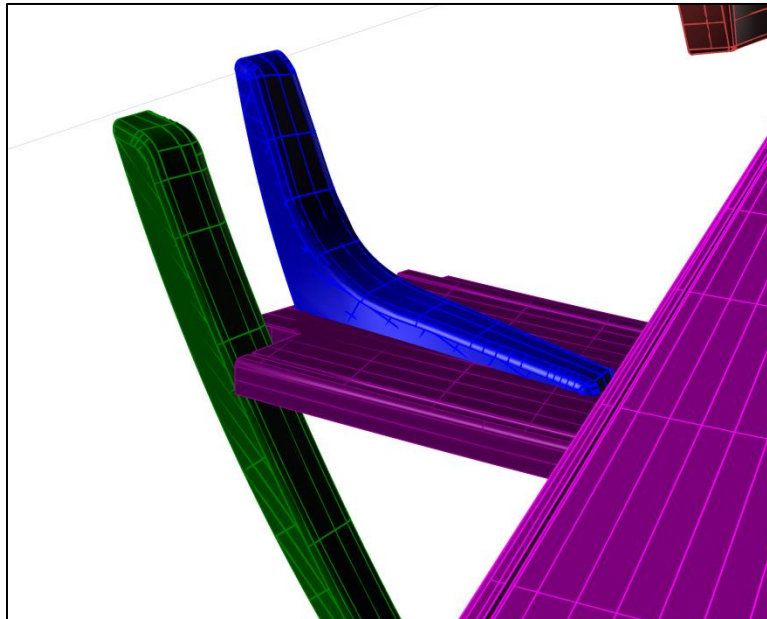

Figure 8: Final Solid Shape for Port Thwart 1 Knee (blue)

In this case, some knee points appear to be within the shape of the thwart. While some knees on *Bessie* are notched into the thwarts, the laser could not have actually recorded points there.

Remodeling the thwart to sag helped fix this issue for some points and my originally-straight thwart was likely the cause for at least some of the error, but some original points on each piece are also simply incompatible with each other.

There are many techniques for modeling different pieces, and one lesson quickly learned is that no two pieces are identical. The port knee for Thwart 1 did not require a lot of troubleshooting, but is relatively rare in that respect. Often a single piece will require repeated evaluation of total station point accuracy, extensive rebuilding of missed points, and several

different attempts to surface and create solids in order to achieve the desired shape. The notes for modeling the Thwart 1 Knees are included within the Modeling Log (Appendix C), and there are far more examples throughout the author's notes of pieces that took several tries to reproduce. Each piece completed also required reevaluation of nearby pieces such as happened with Thwart 1. The result is constant remodeling of different pieces throughout the vessel.

Lessons of Reconstruction

Modeling in Rhinoceros is a complicated process ripe with potential but rife with pitfalls. The next chapter will discuss the results of this process in regards to *Bessie*, but there are a few important lessons of total station reconstruction that cannot be overlooked. As is clear with the Thwart 1 Knee, this process is an addition to traditional recording techniques rather than a replacement of any kind. The total station data is effectively worthless without the extensive drawings and notes that accompany the point cloud, and measured drawings will always be necessary to fill in gaps in the data and double-check the accuracy of the recorded points. There are many ways that total stations and three-dimensional models aid in the reconstruction of a vessel, but it would be overly simplistic to assume that these advances come without legitimate drawbacks.

The theoretical basis for this recording technique remains sound, and benefits the reconstructor in real ways. Boats are complex three-dimensional objects, and this project demonstrates how a point cloud can represent a shape far more clearly than a measured drawing ever could. Even a relatively small piece such as the knee would take several complex drawings from different angles to try to fully recreate on paper. While the digital model is not perfect, it is possible to recreate it with a significantly smaller outlay of time, resources, and data points than

would be necessary for hand techniques. This is particularly important for pieces that are carved out of wood, and could literally take any shape desirable to the boat builder. Recording these pieces in three dimensions allows one to capture the shape of an object without assuming any straight-edges or flat surfaces. Similarly, having a computer model allows one to examine each piece in unique ways. It is impossible to manipulate a drawing to examine it from different angles and get a sense of how or why it was designed to fit into a certain place, but quite simple in the perspective view pane. A physical model could sometimes allow this, but without the benefit of being able to make other parts invisible by turning off a layer. The single biggest advantage to this technique is that everything remains in three dimensions throughout the process.

Similarly, reconstructing in this way forces the modeler to fully understand and appreciate each piece of the vessel, and how each of them fit together. It is easy to understand something in a drawing, but overlook an aspect of strength or utility in how pieces interlock and align within the structure of the vessel. Effectively, modeling in this fashion is just building the vessel again in a different medium. Unlike a two-dimensional representation, the full shape of each piece is considered individually, and then used as part of the larger whole. There is much to be learned from building a model this way. As demonstrated in the discussion of the knee above, one often finds that things do not fit together quite as intended. Sometimes this is simple error, but it can also show the order in which things were necessarily built; some pieces need to be completed so they can define the shape of others. While this sounds straightforward, like any design process there are unforeseen complications, and these obstacles reveal themselves during fabrication. In essence, things look easier on paper. Obviously there are aspects of computer modeling that do not faithfully replicate boat construction (for example a plank can be bent in

any particular way one desires in Rhinoceros), but the process of modeling helps the reconstructor understand how the vessel was put together. While this can be true with some other techniques such as physical modeling, it is a distinct advantage that total station recording has over some other digital techniques such as laser scanning. While a full comparison of these two methods is beyond the scope of this study, a quick glance at any laser scanner data reveals that it captures the surfaces of a target with great accuracy, but is not designed to separate the data into discrete construction elements. The total station is far less automated than the laser scanner and takes longer to collect data, but the data collected is very specific for what is needed to recreate each piece individually and thereby understand the structure better.

The disadvantages of this form of reconstruction fall into two general categories: theoretical challenges, and practical challenges. The theoretical challenges are not entirely different from any form of reconstruction, and involve the decision making used at every juncture. One of the primary advantages of using a total station is the accuracy of laser recording when compared to hand techniques, but this can be a pitfall as well. There are points on virtually any piece that seem out of place when compared to hand drawings or photos. One can assume that these shots were mistakes in one form or another and nudge the point to align with the rest of the data, but to do so is to undermine the accuracy of the instrument. The alternative is to assume that the laser is capturing a feature unseen by the observer, but this runs the risk of trusting a digital data point more than the eye of an archaeologist in the field. Lasers can miss their targets, or find unintended objects to reflect. Ultimately there is no correct answer without the opportunity to go back and re-measure the point, which for many projects is not an option. The entire model is effectively a series of these choices. Every decision affects both the resulting model, and the theoretical advantage of the technique from which it is derived. In this project the

author tried to view each decision separately and use the available data for each point to judge its correctness, but undoubtedly such a middle course ensures both the loss of accuracy at times and unwarranted shaping at others. No reconstruction perfectly represents the original, and though the total station's high level of accuracy is an important aspect of its value, it can also be cause for theoretical consternation when point clouds do not appear as they should.

The practical challenges of this form of reconstruction are many. In addition to problems with accuracy versus precision when capturing the data, the modeling process can introduce error at various points. For example, when a rounded edge is recorded in a point cloud, then reconstructed, and then filleted, the resulting modeled edge will be smaller than the original by the radius of the fillet. The author tried to compensate for this effect when possible, but to do so destroys the advantage of the recording instrument and introduces another form of error when original points are nudged around. If the edge of each surface is recorded before the fillet then the surfaces can be extended to meet and then trimmed, but if the point are recorded along the middle of the fillet then they will need to be adjusted in some fashion. Similarly, there are times that a modeling process will change the shape of an object slightly in undesirable ways. It has been noted that using the "Patch" command to surface complex areas is sometimes necessary, but this command has a low degree of accuracy when creating edges for the surface. Sometimes these can be repaired by adjusted the edges when the solid is constructed, but each step in the modeling process introduces further opportunities for error. It can also be very challenging just to find the right tool to model a surface or curve effectively. Sometimes it can take several different attempts to create a desirable shape only to find that the edges do not align well enough to cleanly fillet them, and the curves and surfaces need to be reworked to build the solid slightly differently. Troubleshooting issues such as these are a constant part of Rhinoceros modeling, and

take significant time and creativity to overcome. So while the total station is very accurate when compared to hand measurements, often this accuracy is lost in the modeling process by both mistake and sometimes necessity.

One of the most important lessons from modeling a vessel such as *Bessie* is that the total station may be far more accurate than a tape measure, but it is still reliant on the precision of the team doing the recording to be useful in any way. A missed point is no better than a misread tape measure, and is arguably an easier mistake to make since the miss may not be noticed until well after the fieldwork has ended. Ultimately there are several advantages to be considered when using this technique, but also severe limitations that must be considered before this methodology is employed. The accuracy of the instrument cannot make up for the precision of the recording team, and though the potential of three-dimension data is profound, the time and effort necessary to process this data is also significant. The results and utility of the *Bessie* model will further discuss this balance in the following chapters, but suffice to say that this process is beneficial, but not ideally suited to every reconstruction project.

CHAPTER 4: THE MODEL

Introduction

Creating a digital model of *Bessie* is intended to answer numerous cultural questions, and address the feasibility of using Rhinoceros for reconstruction projects. While there are several similar projects within the Maritime Studies Program at East Carolina University, *Bessie* remains an excellent test case for the opportunities and challenges of this methodology as one of the earliest full recording projects, and one in which the researcher did not have the opportunity to directly influence the process for better or for worse. In other words, it can serve as a sort of blind test for the technique. The resulting model has myriad useful functions discussed below, but also limitations as to how it can be realistically used. These limitations highlight the difficulties in this particular project, if not necessarily the technique as a whole. There is also room for further research on how best to utilize this technology, and best practice recording and modeling with that goal in mind. This chapter will explore the *Bessie* model, and detail how this adds to the discussion of how *Bessie* was designed, built, and repaired. It will also demonstrate and discuss some of the uses for a digital model in testing the vessel's stability and performance in Orca 3D.

Choices in Modeling *Bessie*

As described in the previous chapter, every timber and piece of *Bessie* was modeled individually to be part of an interconnected system of solid objects, very much like the real vessel. The completed model contains almost 200 structural pieces, and almost 600 more fittings and fasteners. This does not include several items that were not modeled. It became evident

throughout the process that the sheer number of bungs and treenails throughout the vessel made them virtually impossible to represent. It would be interesting and potentially quite useful to model these, but would also require more comprehensive recording to have any sense of accuracy in location or quantity. This is an excellent example of what exactly this model is not: a perfect representation of *Bessie* in digital form. A reconstruction is inherently different from a vessel, and there are many ways that this *Bessie* is inadequate to fully appreciate the original. In some cases this is due to recording deficiencies, in others the modeling program is not fully capable of rendering the desired shape or output adequately, or at least the user was unable to achieve an ideal representation. The process of modeling helped define what these limitations are, and the major decisions that defined the resulting model are laid out below. The modeling log (Appendix C) discusses the specific decisions in greater detail as they came up over the course of the project.

The lack of treenails and bungs is one of the larger omissions in the *Bessie* model, and none of the fasteners are perfect. The metal fasteners were better recorded, but equally importantly they are more easily identifiable in photos. In very few cases were the exact locations noted. The recording team programmed a “Bolts” sublayer into the point cloud, but then only actually recorded the locations of seven bolts with the total station. Several more were noted in the measured drawings, but in most cases they were at best described in general location without discrete measurements. Nails and screws were similar. They are often described in terms of size and general location, but no points were taken on them, and few measurements for them appear in drawings. The fasteners that do appear in the model are located through the combination of descriptions and photos, and are not so much intended to reflect accurate quantity and locations as to provide a general sense of distribution and aid in weight calculations.

Undoubtedly there are many fasteners missing from the model, and it is likely that some of those present are either inaccurate or modeled larger than in reality. Ideally these issues will balance out leaving a general distribution resembling reality. A recording strategy that focused on fasteners would allow for a more comprehensive reconstruction and analysis of these pieces. For larger fasteners (generally of about 8 mm diameter and above) through-holes were made in the appropriate solids to receive them and indicate their presence. For anything smaller (including all nails and screws) the solids were left intact. This is both because the lack of mass actually displaced or removed is not hugely significant, and because the resulting complications of doing so would quickly overwhelm the program and create shapes that are simply too complex to be of any real value for further manipulation. For the same reason, smaller fasteners were given simple shapes that do not require great difficulty to render in great quantities.

The model is also not intended to look exactly like the original. While complex texturing and highly detailed constructions of damage is possible in Rhinoceros, it is not necessary for understanding how the vessel is put together. The modeler did find that different shades of color were useful for giving the model a general appearance and identifying different pieces. To this purpose, textures were created from photos of individual pieces, but in most cases they are highly distorted and pixelated, so useful for the general visual benefits noted above but little else. Similarly, extensive areas of damage or diagnostic features were modeled as well as possible, but smaller bits of damage were often beyond the scope of recreating the vessel, and impossible with the recorded data. Figure 9 shows the completed model rendered with these textures taken from photos.

Finally and perhaps most relevant, the model is not as accurate as originally intended, especially considering the accuracy of the instruments used for recording. As noted in the

description of methodology, this data set contains lots of fairly obvious errors. For some pieces, as many as half the total station points were discarded as either definite or probable misses. The remaining points are still not necessarily accurate; they are just not easily identifiable as wrong. This means that a much larger proportion of the model was built with measurements than ever intended with this methodology. When a three-dimensional shape is reconstructed primarily with two-dimensional data, it both undermines the theoretical benefit to this recording technique, and introduces a huge amount of potential error.



Figure 9: Rendering of Complete *Bessie* Model

Although total station data was given preference whenever possible, the issues present in the data set regularly necessitated using the measured drawings as the primary tool. Similarly, the interconnected nature of the vessel's structure is both a benefit and a problem for modeling. Each piece can help locate and define other pieces, but a mistake discovered late can require remodeling pieces connected to the problematic one, and then the pieces that they touch, and so forth. Ultimately, any small mistake can quickly result in rebuilding virtually everything completed before that point, which makes perfection realistically impossible without infinite

time and resources. The result of these issues is a model that cannot be considered precise in terms of exact dimensions or locations when considering the capabilities of the total station.

Although there are numerous problems, the model is a good representation of *Bessie* as it sits today. One of the most difficult early decisions was what form to actually model the vessel in. The vessel shows numerous signs of damage, wear, and rebuilding from throughout its working and museum life, and a digital reconstruction could have represented the original form, or perhaps an earlier version with only some of the later modifications added by the Manigaults. Instead, the current form was used to both fully utilize the recorded data, and document the full lifespan of the vessel by representing the various changes that have occurred. This also seems to be the best route in light of McGrail and Crumlin-Pedersen's (2006) principles of minimal reconstruction. Whereas a model of the original form might be more useful in some ways, it would also be more speculative; this largely existent vessel presents an excellent opportunity for analysis of a complete model made with a high degree of confidence in the accuracy of general shape and design. This route also provides the most possible data, which can then be used to create other models as necessary or desirable. These offshoots can go beyond minimal reconstruction to test hypothetical performance or for the sake of simplicity in representation. For instance, the current broken form of *Bessie* is not ideal for creating a useful lines drawing, so a parallel model uses the same data but with a complete hull shape that encapsulates both the original log and repair sections into a single useable solid that can give a clearer look at the designed shape of the vessel. Effectively, modeling *Bessie* as it sits today gives the most complete picture of the vessel and its history while still allowing for fairly simple adaptations for further study.

The model is a comprehensive representation of structural intent. In other words, while

the exact dimensions were not always as accurate as desirable, the interlocking nature of each piece was modeled very carefully. This allows for a clear picture of structure, and as discussed later is useful with the ability to isolate particular features or groups within the program. The structural shape is generally well recorded, but the process of reconstruction revealed numerous details about the hull and construction that were not immediately evident otherwise. Some areas that were covered up or would have required deconstruction to accurately record are inferred, but the evident structure allowed most of these to be modeled with a fair degree of confidence.

As noted throughout Appendix C, every piece required decisions that ultimately affected what the model is and is not capable of representing. When considering the results of this modeling process, it is worth remembering that better quality control during the recording process and the lessons learned from the reconstruction can benefit future projects to fine-tune the utility of this technique. This model helps one understand *Bessie* better, but this process can help redefine what is possible with digital reconstruction.

The Log of Digital *Bessie*

The process of constructing the *Bessie* model parallels how *Bessie* would have been constructed in real life. This was not immediately evident, but over the course of the project the necessary decisions for portraying *Bessie* in digital form were increasingly constrained by the same parameters that would have dictated how *Bessie* was built in the 1850s. In particular, everything is dependent upon the log base. This seems fairly obvious for a log vessel, but this is far from simple when it comes to modeling shapes in Rhinoceros. The hull shape is complex, and the log shape is still more complicated. The hull is the defining feature of a logboat and therefore extremely important to the model, but also by far the most difficult part of the project. The

challenge of starting with the log in Rhinoceros is that this data set frequently used other pieces to record the interior surfaces, and these points were best identified and evaluated for accuracy in reference to those other pieces. In other words, philosophically starting with the log is a clear choice, but practically many of the recorded points inside the vessel belong to other shapes. It seemed necessary to understand those shapes first to understand the interior. This would not have been a problem for the original builders since they could carve the shape they wanted and let that dictate how the structure followed, but reverse engineering required a fuller understanding of the framing to dictate the interior hull. In practical terms, this meant that it was extremely difficult to construct the complete log shape when the project started, and so this project began with the floor timbers and futtocks. This was despite the fact that the log both defines the shape of the vessel, and gives the clearest picture of how the builders and owners went about creating and maintaining *Bessie*.

Given the relevance of frame-based versus shell-based philosophies of vessel construction within Maritime Archaeology (to leave bottom-based traditions aside for the moment), there is a certain irony to knowingly beginning a reconstruction project with the opposite philosophy of how the original builders must have proceeded. This was a practical decision, and entirely based on the necessity of understanding the data set available for the reconstruction. However, it was ultimately the wrong decision with this vessel. For the remainder of this project, it became increasingly clear that the same choices make the most sense for building the same vessel whether building digitally or with wood. Although starting with the hull would have required a lot of preparation of other pieces and analysis of non-hull data, it would have been the soundest decision for simplicity of modeling and soundness of theory. Instead, the interior pieces had to be constantly reworked in order to fit around the largest and most important

shape as it was constructed and refined. A recording strategy that prioritized the log shape as the core of the data set would have made starting with the log easier in the reconstruction phase.

Modeling the log included challenges beyond just the limitations of the data; the complexity of the shape was also extraordinarily difficult to reproduce within Rhinoceros. The program is well suited for shapes that encapsulate strange curves and odd surfaces, but it is also primarily a design program where parameters can be bent or manipulated to fit within design constraints. This is a reverse engineering project where the desired shape is not malleable. J. Richard Steffy (1994:15) discusses how this difference in intent often comes up when utilizing naval architecture in reconstruction studies. Design assumes and can achieve perfection, but reconstruction is interpreting the results, which are never perfect. *Bessie's* hull is far from perfect. Building a similar clean hull shape is quite easy in Rhinoceros, but building a unique and highly fragmented shape is not.

Most of the time, the irregularities were successfully created in Rhinoceros by building a larger solid shape and then splitting off carefully defined chunks. The Boolean Split and Boolean Difference commands are essential for removing chunks of hull to represent repairs, through-holes, and odd shapes, but they come at a price. Sometimes the solid did not split perfectly, and individual surfaces and edges had to be rebuilt or manually reconnected. This could involve reconnecting hundreds of minute edges one by one. Every time this was done, the accuracy could be decreased ever so slightly. In the end, the author tried several different strategies for building the hull. These included using the Loft command to create a complete hull shape similar to how a traditional small planked boat could be built, or even taking a literal approach to dugout construction by starting with a solid log shape and then carving off chunks using splitting surfaces built from data points. Despite the appeal of this method for parallels to dugout

construction, the complex splitting surfaces proved too difficult for Rhinoceros. Ultimately, the only strategy that produced a shape resembling the original was to create broad surfaces for the entire side of the vessel with the rail sweep command, and then continually splitting and reconnecting those surfaces as smaller pieces were removed or modified to represent changes or slight irregularities in shape. The final hull solid represents over 170 distinct surfaces with over 500 unique edges that have all been stitched together. Although the accuracy for this is not ideal, it was the only way of creating a hull shape that closely resembles the complex form that the original cypress log now takes. It was necessary at times to accept inaccuracies at specific data points in order to create a better complete shape – to ignore the trees for the forest. For the vast majority of the vessel the surfaces are within 5 mm of the original, though at select trouble spots they can be as far off as 20 mm or more. Figure 10 shows the final solid for just the remaining log portions of *Bessie*.

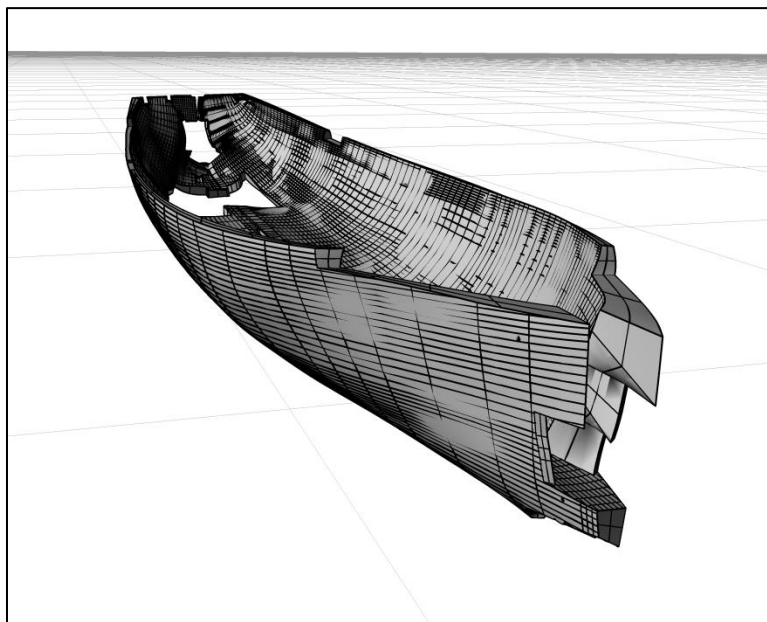

Figure 10: Final Shape of Remaining Log in *Bessie*

The challenge of getting Rhinoceros commands to form odd shapes can also be a huge advantage for finding irregularities. At times it would have been quite easy to produce a shape

with a clean curvature that would look and act like a boat similar to *Bessie*, but the natural curves instead reveal irregularities in the data. As noted before, a carved log hull means that there are no rules for the shape that the log could take. Although clean lines were probably intended by the builders, there is no reason to think that this was always achieved. An example of this can be found on the port quarter of the bow on the exterior hull. The point cloud in this area shows that these sections flatten out somewhat halfway up the hull, and create a flatter upper area of the hull and a sharper curve near the chine. On a planked vessel, this would be impossible given the natural curvature of wood, and would suggest the data is flawed. On a carved vessel, there is no reason to think this is inaccurate. The data certainly could be flawed for reasons that have been discussed, but in this case the sum of the evidence points to a hull abnormality. Multiple stations show this flattening, and to correct it would be to discard data for the sake of congruity.

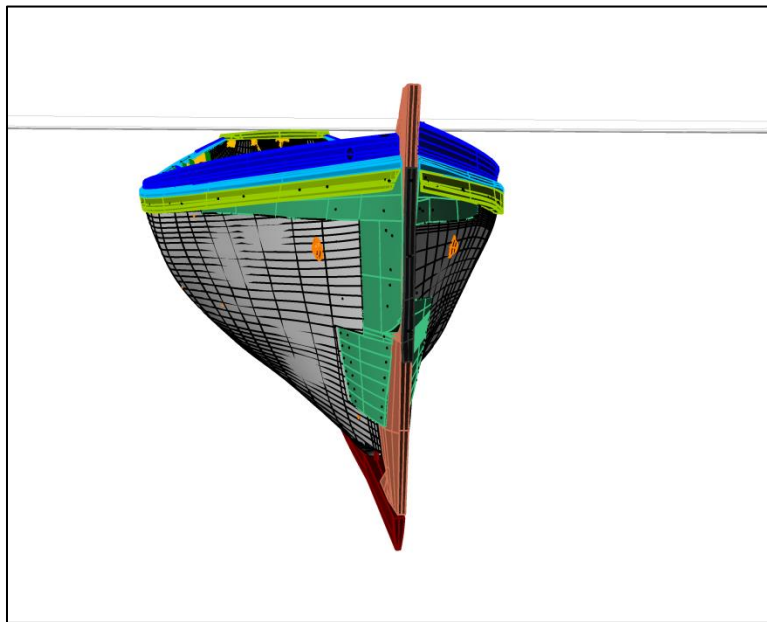

Figure 11: Bow Shape with Flattened Port Quarter

While the same results could be obtained from traditional recording techniques, this was first and best observed during the surfacing process when compared to the starboard side, and could easily be missed or corrected in a traditional lines drawing where it is harder to visualize the product of

an irregular section or two. The ability to easily depict both a faired and actual version of incongruities like this is another advantage of computer modeling. Figure 11 shows the flattened shape of the port bow when compared to the fuller rounded starboard. Although this is a relatively minor imperfection in form, it does speak to the possible outcomes, desirable or not, of carving a hull shape that would typically be built with planks.

Repairs from the Life of *Bessie*

The most striking feature of the hull is the extensive decay and damage evident in the original log, and the wood that was added to reform the hull. Various repairs had been made up through the time *Bessie* began its residence at the Charleston Museum, and some clearly date to the working life of the vessel (Stewart et al. 2012). Although a single log was enough to form the complete overall shape, the oldest repair sections show that the core of the tree was probably insufficient from an early time period, and possibly from the original time of construction. The remaining bow section is effectively a mess of different repairs and added pieces, some of which show aging and wear patterns similar to that of the hull. One of the large repair blocks in the bow has a bolt to secure a mooring ring passing directly through it, implying that this was installed during the vessel's working life, and likely when *Bessie* was built. If a repair block was needed so early, the log was probably never sufficient to be the sole piece of wood forming the hull.

Reconstruction showed that the bow is actually even more complicated than it first appears. The drawings and points capture several different repair sections, but the recording data leaves a void in a section of hull in the same area as the through bolt. This space is just aft of the upper stem, forward of the breasthook in-between the port section of log and a starboard repair plank noted by the recording team (Stewart et al. 2012). The hull is definitely solid in this section

as shown by photos hinting at the presence of wood. A roughly triangular shape is therefore either an odd projection off the back of the stem that was left off of the recording drawings, an area of the port side log that juts out more than a few inches further down, or is another repair block inserted to fill this void. Without positive identification, it has been modeled as a repair block as can be seen highlighted in yellow in the wireframe view of the bow in Figure 12. Which piece actually fills this void is not as important as the fact that it is there, and it is filled. Regardless of how the boat builders filled the void, one of the three pieces of wood was intricately shaped to fill this space and make this section of hull solid. This intricate sculpting both demonstrates the skill of the woodworkers, and shows how they approached issues of hull decay.

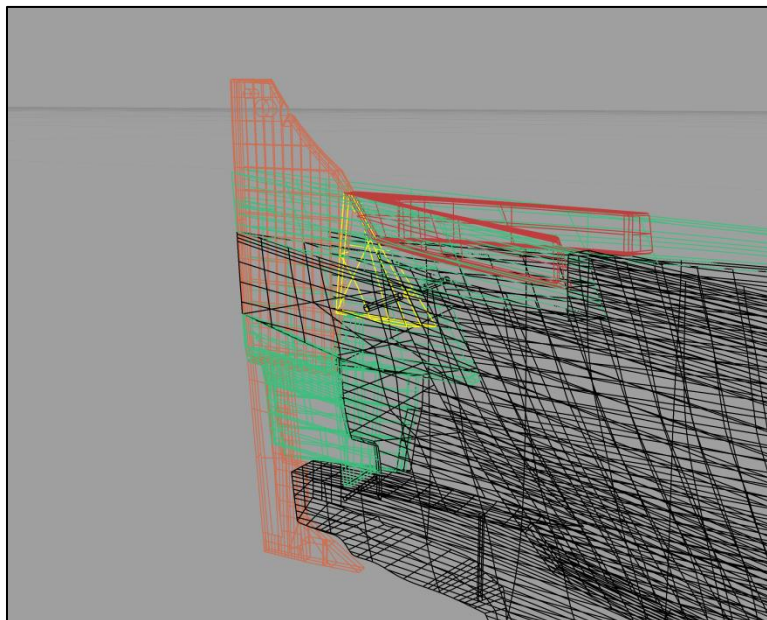

Figure 12: Void Filling Block in the Upper Bow behind the Stem

It is evident throughout the bow that repairs done earlier are meant to fill out the log, rather than just patch over sections or make them waterproof. Later repairs that appear to have been made by the museum simply plank over problem areas and holes (with no real intention of waterproofing at that point), but the earliest additions show an inclination to fill a space rather than just

waterproof it. Additional photos of the bow and some of the repair work can be found in Appendix A, Figures 21, 22, 23, 24, 33, and 34. While not every area of decay has been filled, the various chunks of wood meant to do so are clearly visible. This same philosophy is even more evident in the stern.

Bessie's hull has a delightful wineglass-shaped stern that was probably originally all carved into the appropriate shape, but is now just as much a jumbled repair area as the bow. The keel is missing, most of the transom is repair or filler blocks, and the lower stern is another area that was planked over after the working life of the vessel. The central and upper areas of the transom reaffirm the patching mentality of the builders or owners. There is a large cypress block in the center of the transom that forms the core of the wineglass shape, and extends forward into a cavity in the log. Figure 13 shows this repair block in yellow.

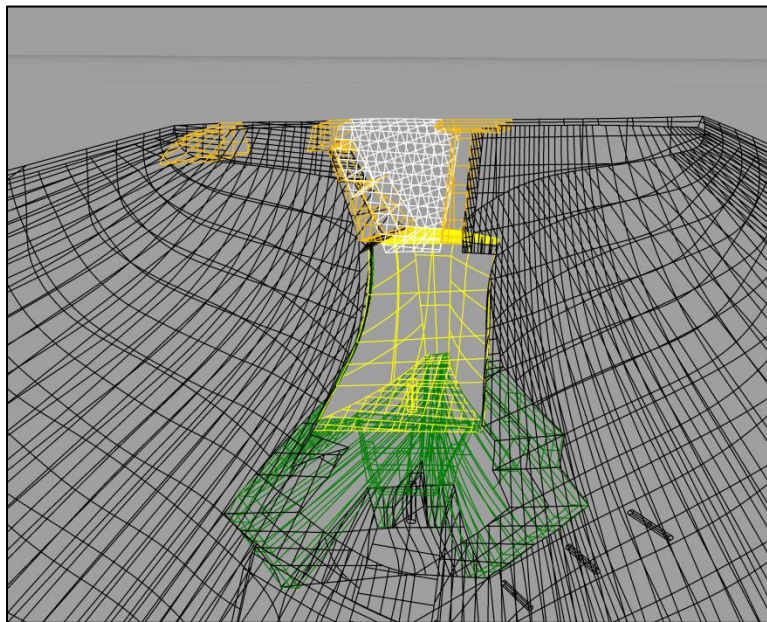

Figure 13: Stern Repair Area with Cypress Repair Block

While it is impossible to evaluate the full decay of the log in that stern section, the reconstruction process made it increasingly clear that there is very little connected structure remaining. This area is covered by a small stern deck that would need to be deconstructed to verify the level of

degradation, but the run of the interior surfaces and extent of the repair work suggest that the entire stern midship log is either missing or severed from the continuous hull. Additional filler chunks appear in orange in Figure 13, and the later planked repair sections in green. The white area is a cypress hull chunk that appears to be part of the original log in its original location, but severed from the rest of the hull. The grain patterns in the wood match the surrounding area, but the orange repair blocks show that it is entirely isolated from the main log, or at best minimally connected in a non-structural capacity. As with some of the bow repair chunks, the interior shape of the orange filler sections is not always clear; the recorded outside shapes suggest that many of these may be wedges shoved into gaps and carved to be flush with the hull surfaces. Similar to the bow, there is a huge difference between the later green repairs that use planking to make the hull look complete, and the earlier repairs that attempted to rebuild the solid log. Although it is difficult to say if a waterproof plank repair would have been easier or more challenging than filling out the solid hull structure for these areas, the carefully crafted shapes that conform so closely to the remaining log and hull shape suggest that great carpentry skill was required to rebuild this section.

The last large repair area is just forward of the stern, and is a large section of hull that was replaced sometime during the working life of the vessel. The recording team notes (Stewart et al. 2012) that a large transverse crack formed on the port side of the hull, and though metal strips were installed to try to stabilize it, a large section of log is missing just forward of the small stern deck and aft of floor timber 9. Photos of this section can be found in Appendix A, Figures 47 and 48. The repair of this section is somewhat different given the size of the hole, but even with a different approach the same philosophy of repair is evident. Two floor timbers were added to this section, and then yellow pine planking was installed to fill in the gaps. While this is

more representative of frame-based construction than other repair areas, the thick planks are fit into the hull in such a way that they are still serving to replace the damaged area rather than just patch it. The exterior of the starboard repair area is carved smooth with the hull, so that the repair is barely noticeable from the outside. The port was likely similar except that it has been blown out at some point since the vessel was removed from the water. While the planking is easily distinguishable from the log inside the vessel, great care was taken to fit them into the interior surfaces as well. The starboard-most plank is carved and shaped to conform to the log edges in such a way that the repair pieces almost appear to be joggled into the hull in that area. The same can be said for the port side planks just aft of where the blowout occurred. Similarly, an additional small repair section just aft of here consists of small planks fitted carefully together in odd shapes to conform to the interior hull shape. So while a plank repair was necessary for such a large section of the bottom of the hull, the inclination still seems to be to replace the solid log as much as possible rather than just patching or waterproofing an area.

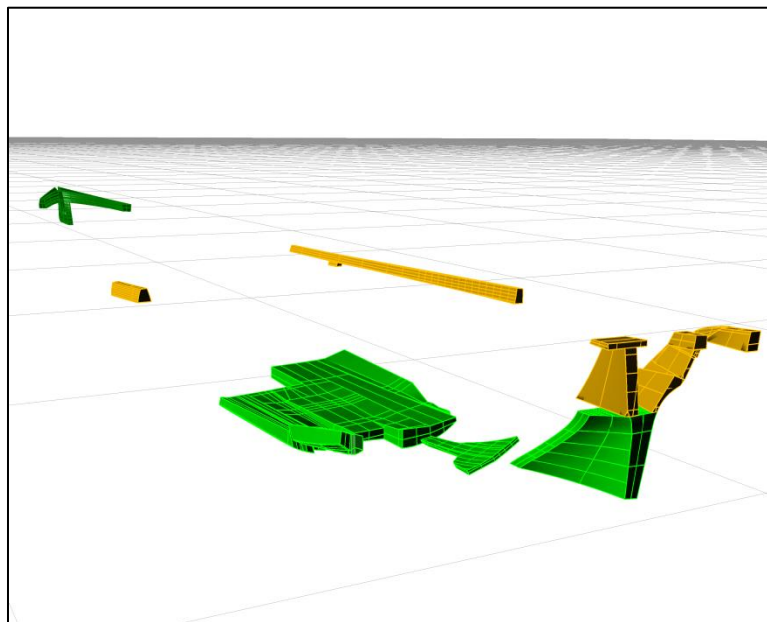

Figure 14: Repair and Filler Blocks Fitted into the Log Hull

Even thinner planking might suggest a different philosophy, but these thick elaborately-shaped

pieces are as much filler blocks as outer hull planking. Repairs were done in a way that maintained the shape of the log as much as possible, and skillfully enough to minimize any outward appearance of damage. Figure 14 shows the extent of repairs of this nature throughout the hull: these solids are all repairs or fillers that are intended to replace missing chunks of the log, and does not include repair planks added by the museum.

Interpretation of *Bessie*'s Build

One interpretation of this repair philosophy simply serves to reinforce the obvious: that *Bessie*, a log boat, was constructed with a shell-based philosophy. Each repair served to rebuild the structure of the hull as completely as possible. However, the other 700 or so solids that form the model show that it was not quite that simple. *Bessie*'s overall shape is that of an elegant launch that is generally associated with plank-built vessels, most often frame-based. The internal structures of *Bessie* do more to reinforce that general association than dispel it. The interior features a series of 13 frames that run the length of the vessel, most of which consist of futtocks resting on top of floor timbers and spanning the hull virtually gunwale to gunwale. A stringer, or clamp, runs down each side of these futtocks and is notched for a series of seven thwarts that rest on top of the stringers. These thwarts are notched in turn for small rising knees, which secure the thwarts to the hull and parallel the upper ends of the futtocks while also providing more longitudinal support by angling towards the bow and stern. There are additional elements such as mast steps that run along the floor timber tops almost like a keelson for the forward section, and mast partners that join the thwarts together. Figure 15 shows only the internal structural elements of *Bessie* without the interposing log. This support structure is described in much greater detail in an as-yet unpublished article written by the recording team (Stewart et al 2012), but suffice to

say here that weight and forces acting on the vessel are redistributed along the various structures by this interlocking system.

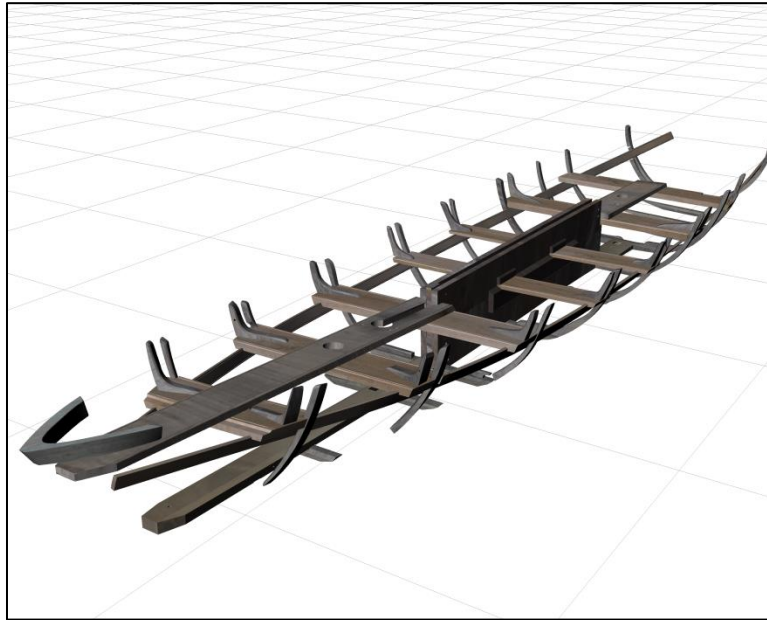

Figure 15: Internal Structural Elements of *Bessie*

The centerboard trunk was added later and actually bisects some of these elements. It is not integrated well enough to add a lot to the structural system, but it also does not significantly weaken the arrangement.

Similar to the framing, the recorded fasteners support the idea that *Bessie* was not built with a strictly shell-based philosophy. The recording team noted (Stewart et al. 2012:25, Fleetwood 1995:41) that the high cost of metal fasteners might have discouraged plank vessel building on plantations during this time period, but the choice to build *Bessie* with extensive internal framing suggests that the added expense was deemed necessary. A simpler log vessel would not require the same extensive use of expensive metal fasteners, but the added structural elements ensured that *Bessie* did. Figure 16 shows the distribution of metal fasteners throughout *Bessie*. As has been noted, the exact locations of fasteners were not carefully recorded, but the general distribution is accurate, and if anything probably under-represents their presence.

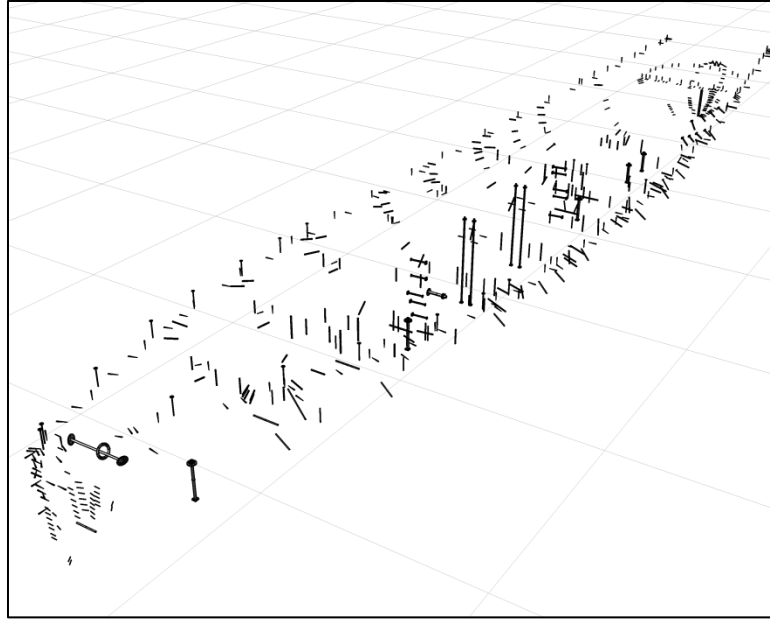

Figure 16: Metal Fastener Distribution throughout *Bessie*

If the builders were solely committed to the log as the core of *Bessie*'s structural integrity, this much fastener use seems unlikely.

The flaw to considering this structure as the basis for rethinking *Bessie* as a frame-based vessel is the lack of a longitudinal strength other than the hull; the keel is in multiple sections and could not serve as a primary foundation without the hull, though it was likely more useful than just as a shoe as noted by Fleetwood (1995:40). It is thick enough to provide some level of support, and probably helped with stability and heeling as well. However, if the bottom of the hull can be interpreted as a glorified keel, then the structural elements are in place to build a traditional planked vessel. Given the amount of internal structure and the importance of the log as the longitudinal strength, it is worth exploring the relevance of bottom-based construction as a factor in this design. Fred Hocker identifies (2004:66) the defining feature of bottom-based construction as “the choice of the bottom of the hull, rather than the shell or skeleton, as the principal component.” He further generalizes that such vessels typically feature flat bottoms for use in inland waterways, and often different construction techniques or materials used on the

bottom and sides of the vessel. Although categorizing *Bessie* as bottom-based would certainly be a stretch, it does feature a relatively flat bottom for most of her breadth, and the thickness at the bottom is recorded as 5 cm, compared to 4 cm at the turn of the bilge and 3 cm near the gunwale. The extensive use of depth gauge pegs evident from construction indicates that this change in thickness was entirely intentional, and there is more strength in the bottom of the vessel than the rest of the shell. Although a thicker bottom is typical for a dugout, that does not make it any less significant as the structural heart of the vessel.

The relevance of this hull shape and internal framing is that defining *Bessie* as shell-based is overly simplistic. With the addition of a true keel and a little more structure in some areas, the log would not be required to form a boat with this framing: planking would probably suffice. Similarly, the log that became *Bessie* could have been carved into a vessel that did not require framing of any kind: chapter 5 will discuss similar size dugouts in other regions that do not seem to require comparable framing. Finally, the bottom of the log with the framing could easily have formed the basis for a vessel with planked sides. This would result in a look similar to the Brown's Ferry Vessel (though smaller and with a wider flat bottom), found within the same region and dating to roughly a century before. Fred Hocker suggests (1991:248) that the Brown's Ferry Vessel could be a sort of "vestigial log boat" based on the application of the colloquial term *periagua* (derived from the Spanish *piragua* for log boat) to it, making the bottom-based comparison all the more plausible for *Bessie*. Essentially, although *Bessie* technically must qualify as a shell-based boat based on the literal use of a shell as the primary structure and flotation device, there are elements of frame and bottom-based philosophies that are incorporated into the design. The repair methodology demonstrates a commitment to the shell of the vessel throughout its working lifespan, but the inclusion of extensive interlocking

structural elements indicates that the builders had both knowledge of and interest in utilizing frame or bottom-based philosophies in the vessel. Ultimately *Bessie* is still a logboat, and still a shell-based vessel, but one which values the strength of the bottom of the shell more than that of the sides, and utilizes extensive framing that is not strictly necessary in the construction of comparably sized dugout vessels. This suggests the bottom of the vessel was built to endure a lot of abuse that might come with groundings or perhaps submerged navigation hazards that can be common in rivers. The framing would have allowed for narrower sides that could have been somewhat lighter than a thicker hull, or have allowed for a narrow hydrodynamic vessel with slightly more interior space for crew or cargo.

Bessie in Orca 3D

Although cultural analysis is often the reason for completing a reconstruction study, the much simpler considerations of vessel performance are equally useful. Understanding how a vessel performed or how well it functioned can in turn aid understanding of why it was designed how it was, and how it might have been used. Thus, the practical or technical data can directly contribute to cultural understanding. Calculating performance is not easy, but is something that has been done in various ways throughout the development of reconstruction studies. At its most basic form, a hull size and shape can be analyzed to determine a vessel's tonnage or carrying capacity, from which other things can be inferred. With more information, calculating a variety of statistics up to and including hydrodynamic and hydrostatic properties is possible. Seán McGrail has been a leader in this field for some time. He has published reports on several vessels including the Hasholme logboat (1988) and the Clapton logboat (1990) that used a series of mathematical models to look at the potential for carrying capacity, stability, and speed of the

vessel under different circumstances. While McGrail, Ole Crumlin-Pederson (2006), and J. Richard Steffy (1994) all caution that modern naval architecture principles and data should only be applied to historical vessels with sufficient information and treated with some healthy skepticism, *Bessie* is a good subject for at least some testing given the relatively intact nature of the artifact. Since modern naval architecture is primarily done digitally for convenience, digital modeling holds great promise for exploring the performance of historic vessels with the same software. In this case, Orca 3D is a plug-in naval architecture program that allows the testing of hull shapes and vessels created within Rhinoceros. Although neither the tests nor model are perfect, this has great application for further exploring how *Bessie* could have been used and what principles went into the design.

The biggest drawback to using Orca 3D on *Bessie* is still the nature of using a design program to interpret something already existent. The full features of Orca 3D allow a user to design a hull, assign materials, assess building costs, and ultimately explore how the vessel would perform under various conditions. *Bessie* can be tested, but any aspects of the model that do not completely conform to *Bessie*'s functioning condition could change the outcome of tests significantly. This is one case where a model of the original condition of *Bessie* would be more useful than the current-condition model built for this project. Additionally, there are shortcuts for design that cannot be taken with *Bessie*. Modern building materials are more consistent or predictable in terms of weight manufacturing tolerances than a hand built boat of natural materials. The model is useful in that this program can far more effectively calculate the volume of a massively complex shape such as the remaining log structure than any traditional calculations of hull size and weight, but the total is probably not as accurate as if it were built of modern materials with modern methods. Similarly, Orca 3D is capable of propulsion testing that

is not entirely applicable to *Bessie*. The cultural context of this study primarily concerns *Bessie*'s earliest years when it may have sailed but was certainly rowed, and Orca 3D does not have rowers as a programmed power source as part of its propulsion testing system. So there are theoretical and practical limitations on the effectiveness of this program, yet it can still provide some ideas of capability that would otherwise be impossible with a boat that will never again be seaworthy. The *Bessie* data derived from Orca 3D cannot be taken as proof of its capabilities in the 1850s, but is a general guide for how *Bessie* might have performed as a functional vessel.

The first step to using this program is assigning density values to the materials used throughout the model. As noted, the model would be better suited for this purpose if it was based on the original configuration of *Bessie* before any museum repairs which were obviously unintended for seaworthiness. Without knowing how exactly repairs to the bow and stern areas were completed during the working life of the vessel, the current materials were used. The weight properties will at least provide a placeholder. The relatively small amount of yellow pine compared to the overall size of the vessel and its comparable density to cypress will minimize its impact on the total calculations. A weight property for iron for the fasteners is easily determined from any number of engineering guides, and is likely not hugely inaccurate despite slight differences in metallurgy. Since the number and exact proportions of fasteners is estimated, this is an inexact calculation regardless of exact alloys or ores used in fastener production.

The wood is far more complicated. Wood varies greatly in density species to species, within a species, and even within the different parts of a single log. Additionally, the water content greatly affects the density, and this can also vary within a single log. Although *Bessie* shows signs of paint (Stewart et al. 2012) and may have also been tarred or additionally waterproofed, Fleetwood (1995: 111-112) notes that sources suggest log boats were still far

heavier than their planked cousins due to water absorption. This is not easily accounted for. Based on a U.S. Department of Agriculture handbook (Forest Products Laboratory 2001), density of wood is generally recorded by specific gravity taken with the mass of oven-dry wood, and the volume of either green wood or wood at 12% moisture content. Since the volume of the wood changes as it absorbs water (up until it reaches about 30% moisture content, or 30% of the oven-dry mass added in moisture), there are several variables for how dense the hull could be even if it were not immersed. The immersion makes this more complex, and even with these variables controlled, there is up to 10% variation within a species (Forest Products Laboratory 2001:3-5). With the oven-dry specific gravity, some amount of water mass (depending on moisture content) can be added to the actual wood mass to get at least a general idea of density.

For cypress, Forest Products Laboratory (2001:4-6) lists the base specific gravity at 0.42 (which is oven-dry weight at green volume), which calculates to a density of 420 kg/m^3 . At 12% moisture content, the specific gravity changes to 0.46, with a combined density (wood mass and absorbed water mass combined) of 515 kg/m^3 . However, Cypress is an extremely absorbent wood, which can have a green moisture content of 121% in the heartwood, or 171% in the sapwood. A finished cypress product would likely not have water content that high (a moisture content of 146% would make it sink based on its specific gravity), but it is safe to assume that a cypress log hull has a high potential for water absorption, even when painted. To that end, calculations were made with density assignments of 12% moisture content (515 kg/m^3) as a relatively dried out log, 30% moisture content, which is noted as the minimum below which most wood properties begin to change as they dry out (546 kg/m^3), and 146% moisture content (1029 kg/m^3) which would represent the extreme, which is basically green wood with equal parts heart and sap wood. In reality the moisture content would constantly be changing based on

weather conditions, duration of immersion, and other factors, so all of these densities are estimated and would vary. The use of the entire log also ensures that the moisture level would likely vary throughout the hull as well. Without immersion being a relevant factor for the other materials, 12% moisture content was used for the live oak and southern yellow pine materials which were assigned specific gravities of 0.88 (977 kg/m³) and 0.59 (656 kg/m³) respectively. All specific gravities and resulting densities for these wood species were either noted or calculated with guidelines from *Wood Handbook – Wood as an Engineering Material* (Forest Products Laboratory 2001).

The final consideration for weight purposes is the occupants and cargo. Again, this is highly variable depending on how many rowers were being used, how many passengers were along, if anything was being transported, and how it was stowed on the vessel. For the purposes of testing, points were created in Rhinoceros at likely seating spots for occupants. Five are placed on the thwarts just forward of the oarlocks, and a sixth on the stern deck for a helmsman. These points were assigned a weight value of 70kg to roughly represent a person. Seán McGrail used 60kg for his estimation of weight for an individual crewman and gear when examining the Hasholme logboat (1988), but those calculations were for ancient humans and seem low for slaves or planters in the 1850s. While this could be considered a basic crew for the rowing configuration, tests were also performed with the addition of more passengers and various cargo configurations.

With the densities established, each individual solid can be assigned a material within Orca 3D. Once this has been done, the program can run a hydrostatics and stability analysis on the hull. Since the existent model includes the damage and wear to the hull, the tests were performed on a separate surface that represents the undamaged exterior shape of *Bessie* without

holes or multiple pieces. The weight calculations are still based on the solids meant to approximate the weight of a seaworthy *Bessie*, but the un-weighted surface is important for testing what would actually be a viable hull. With these tests, it is possible to establish the center of gravity, the center of buoyancy, the trim, heel, draft, freeboard, and all manner of more complex naval architecture values for the vessel. Some of the basic results of testing with various combinations of hull density, crew size, and conditions are shown in Table 1 with a cypress moisture content calculated at 12%, Table 2 with a moisture content calculated at 30%, and Table 3 with a moisture content calculated at 146%. These calculations were done for freshwater, where *Bessie* was primarily used in the Santee River system.

The data in the three tables show that under differing weights and circumstances, *Bessie* remains a fairly useful vessel, but with some stability concerns. The difference in moisture level accounts for a huge difference in empty vessel weight, yet that affects the navigable draft by only 9 cm, and the draft (including keel) is only 30 cm total when empty. Even heavily loaded with 12 crew and 300 kg of cargo stowed in the hull (tests were done with 200 kg in the more open stern area, and 100 kg forward of the centerboard trunk), *Bessie* would still draw less than half a meter, and be a very useful vessel for a shallow riverine environment. The draft data tracks with the weight changes as one might expect. The slight heel and trim accentuates with increased load capacity or hull weight, but that could easily be counteracted with simple measures taken by the crew. The transverse metacentric height drops with each addition of passengers with their higher center of gravity (the point loads were placed on the thwarts), but goes up slightly when the ship is ballasted with the cargo load in the bottom of the hull. At no point does this measure of general stability drop dramatically.

# of Passengers or crew / Cargo (kg)	Displacement (kg)	Heel at Rest	Trim at Rest	Draft (m)	Transverse Metacentric Height (m)	~Max Righting Arm (m) / Angle of Max Stability (AMS)	~Angle of Vanishing Stability (AVS)	Block Coefficient (Cb)	Max Section Coefficient (Cx)	Prismatic Coefficient (Cp)
0/0	815	2.48°	0.21°	0.21	0.66	0.29/40°	53.5°	0.34	0.55	0.62
6/0	1235	3.85°	0.68°	0.29	0.54	0.21/30°	47°	0.35	0.58	0.61
12/0	1655	4.32°	0.76°	0.34	0.46	0.16/28°	41.5°	0.38	0.61	0.62
12/300	1955	3.22°	1.13°	0.39	0.49	0.16/25°	40°	0.38	0.61	0.62

Table 1: *Bessie* Performance and Stability with 12% Cypress Moisture Content

# of Passengers or crew / Cargo (kg)	Displacement (kg)	Heel at Rest	Trim at Rest	Draft (m)	Transverse Metacentric Height (m)	~Max Righting Arm (m) / Angle of Max Stability (AMS)	~Angle of Vanishing Stability (AVS)	Block Coefficient (Cb)	Max Section Coefficient (Cx)	Prismatic Coefficient (Cp)
0/0	854	2.50°	0.20°	0.22	0.65	0.28/37°	53°	0.35	0.56	0.63
6/0	1274	3.85°	0.67°	0.29	0.54	0.21/30°	47°	0.36	0.59	0.61
12/0	1694	4.32°	0.75°	0.34	0.46	0.16/25°	41°	0.38	0.62	0.62
12/300	1994	3.23°	1.11°	0.40	0.49	0.16/25°	39.5°	0.38	0.62	0.62

Table 2: *Bessie* Performance and Stability with 30% Cypress Moisture Content

# of Passengers or crew / Cargo (kg)	Displacement (kg)	Heel at Rest	Trim at Rest	Draft (m)	Transverse Metacentric Height (m)	Angle of Max Stability (AMS)	~Max Righting Arm (m)/ (AVS)	~Angle of Vanishing Stability	Block Coefficient (Cb)	Max Section Coefficient (Cx)	Prismatic Coefficient (Cp)
0/0	1463	2.92°	0.05°	0.30	0.55	0.22/30°	46°	0.40	0.61	0.66	
6/0	1883	3.82°	0.45°	0.35	0.49	0.16/25°	41°	0.41	0.64	0.65	
12/0	2303	4.21°	0.52°	0.40	0.44	0.12/25°	36°	0.43	0.66	0.66	
12/300	2603	3.29°	0.85°	0.44	0.46	0.12/20°	34°	0.43	0.65	0.65	
12/900	3203	2.23°	1.4°	0.53	0.49	0.10/15°	30.5°	0.42	0.65	0.65	
12/1500	3803	1.58°	1.84°	0.61	0.51	0.08/15°	26°	0.43	0.66	0.65	

Table 3: *Bessie* Performance and Stability with 146% Cypress Moisture Content

The stability is more troubling when considering the righting arm and heeling data. The righting arm represents the forces (gravity and buoyancy) acting on the vessel to try to return it to an upright position, and the angle of max stability (AMS) represents the heeling angle at which these forces are greatest. The angle of vanishing stability (AVS) represents the angle at which the forces are at equilibrium, and the vessel is equally likely to overturn as right itself. Any angle greater than the AVS will result in capsizing without outside intervention. It is noteworthy that these values are relatively low. For example, with only six passengers and no cargo, the 30% moisture content hull would start to get less stable when listing past 30° (AMS), and would overturn without intervention when listing past just 47° (AVS). More alarmingly still,

these numbers drop with the additional of passengers and cargo. The same moisture content with 12 passengers and 300 kg of cargo drops the AMS to 25° and the AVS to only 39.5°. Effectively, *Bessie* grows less stable as weight is added (especially weight higher on the thwarts) and would have a tendency to roll more with a heavier load. A more stable vessel would gain stability when cargo or ballast is added. These numbers show that adding cargo down in the hull makes the AVS decrease less than adding passenger weight on the thwarts, but it still decreases. To find the limits of the vessel, additional tests were done with the maximum hull weight of 146% moisture content. The same maximum 12 occupants were used, but the cargo load was increased to 900 kg, and then 1500 kg, still distributed with twice as much in the stern as the bow. The results showed similar patterns. *Bessie* quickly loses what stability it had, and could heel only 25° before losing stability at the highest load test. The resulting draft of 61 cm would only leave about 12 cm of freeboard on the model, so this is not a realistic load condition and entirely hypothetical. It does show that *Bessie* could technically carry quite a bit more weight than one might expect for a vessel used primarily for personal transport or recreation, but that one would be likely to capsize the vessel in doing so.

The coefficients reinforce ideas generally quite obvious from the shaping of the hull; although it is a logboat, *Bessie* has the shaping of a far more efficient vessel than one might expect for a dugout, especially near the bow and stern. The low values of the block and midship coefficients throughout the data speak to the clean underside of the hull, and the intention to have a swift boat with minimized drag. The prismatic coefficient highlights the extensive shaping near the bow and stern. All of these values fall well below the levels Seán McGrail (1988:39) lists as indicative of a relatively fast hull for a displacement vessel. *Bessie* may not have been a race boat, but it was designed to be quick and efficient.

As noted at the start of this section, taking these calculations at face value would be inappropriate. It is highly likely that the weight calculations for the hull are incorrect in some ways, and these calculations were intended for design rather than historical interpretation. Some of the speed tests and other features Orca 3D is capable of do not function properly with this model, likely because the oddity of the carved and damaged shapes were never envisioned in the test software. This data is helpful to get a general sense that *Bessie* was a competent watercraft in some respects. Without knowing the reality of the moisture content of the cypress during *Bessie*'s working life it is especially difficult to look at performance data with confidence, but the sum of the information is that *Bessie* was moderately stable with lighter loads, but much less so as weight increased. The hull does appear to be designed for speed and efficiency. Further work with the model, the materials, and Orca 3D could enhance this data set, and explore additional concepts like how *Bessie* might perform in a rough sea, under sail with different rigs, or with the centerboard down. While the performance data is perhaps the most exciting application of Orca 3D for maritime archaeology, some other basic functions can also be useful. Figure 17 shows a lines drawing for *Bessie* generated by Orca 3D based on the surface used for performance testing.

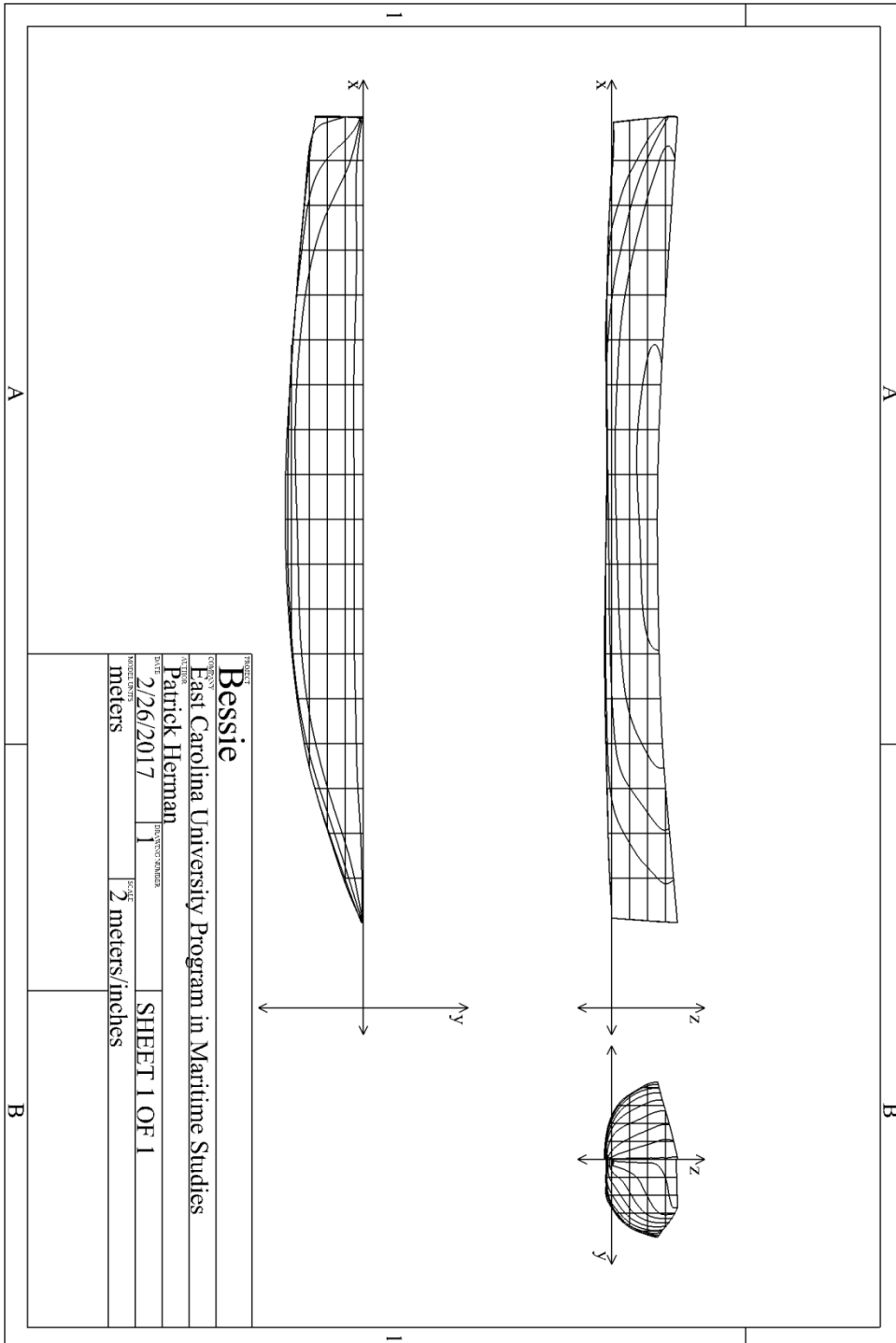

Figure 17: Lines Drawing of *Bessie* Generated in Orca 3D

CHAPTER 5 - INTERPRETATION, CONCLUSIONS, AND FUTURE WORK

Introduction

The preceding chapters have outlined the cultural environment that developed *Bessie*, established a methodology for digitally reconstructing vessels, and explored the utility of creating such a model by examining *Bessie*'s hull shape, repair sections, and hypothetical performance. This chapter will aim to place the technical observations within the larger cultural setting, and synthesize what one can say about plantation boats from this study. It will also discuss the practicality of the methodology employed here, and aim to outline further areas of study and advances that will benefit this avenue of research. *Bessie* is an excellent prototype study, and reveals both the flaws in this methodology and the potential for improvement.

Where does *Bessie*'s Design Come From?

As has been noted, even a technical reconstruction study ultimately comes back to culture, and the desire to better understand the parent culture that has produced the object of study. Material culture theory outlines how the form and uses of an object can inform later generations about the cultural values and biases that went into creating the surviving artifact. As has been noted by Henry Glassie (1972:153), as ubiquitous and generally culturally significant objects, boats are commonly used for this endeavor. So, the crucial questions are why was *Bessie* built as it was built, and what can that tell us about the planter culture it came from? While historical data for the 1850s is fairly extensive, the archaeological record can help us better appreciate the nuances that may not appear in documentation from the period. *Bessie* is therefore best understood in the context of its environment, and the details of its form, construction,

repairs, and capabilities can further the understanding of that same cultural context.

One of the enduring controversies surrounding any dugout studies in the southern United States centers on the role of various cultural influences that could benefit or shape (figuratively and literally) the vessels constructed in the nineteenth century. A cursory appreciation of the history of the region immediately brings up at least three possible influences stemming from the intermixing of the vastly different cultures of indigenous Carolinians, African bondsmen, and European settlers. As with virtually every other region on earth, each of these cultures has a long history of creating dugout vessels of one kind or another, and each would be able to contribute to the design or construction process in some ways. *Bessie* was probably built by slaves of African origin, for settlers of European origin, in an environment long inhabited by Native Americans. Lynn Harris has studied this maritime tableau extensively in her book (2014) *Patroons and Periaguas*, and found that the culture of lowland South Carolina is a combination of all three in which the community of cultures utilized the best of their abilities and environment to produce a tremendous variety of vernacular watercraft. This creole thesis is almost certainly accurate for the broader maritime cultural landscape given the diverse population inhabiting it, yet it is still worth exploring how this particular vessel's physical form may have been impacted by the cultures around it to better understand the micro-culture producing and using plantation boats in this era.

African culture has an obvious connection to *Bessie* through the slaves that almost certainly built it. While it is highly likely that the builders were born into slavery and cultural mixing, it has already been noted that native Africans were highly valued for skill sets and knowledge they possessed from their previous lives, and these skills would undoubtedly be passed from generation to generation with the blessing of masters interested in increasing the

value of their slaves. So an African canoe-builder would certainly pass on his knowledge of design to a younger generation of bondsmen. Though their knowledge of carpentry and boat-building would change with additional training and use of different tools and techniques, the traditions of their parent culture could be present as well.

It would be problematic to generalize too much about the common features of vessels on any entire continent, and Africa undoubtedly produced a wide variety of watercraft in the eighteenth and nineteenth centuries. Additionally, Eberhard Falck notes (2014:162) that the African cultural taxonomy of watercraft tends to differ significantly from that of Europeans, so it can be challenging to use historical records to trace or define a particular hull shape when traditional terminology tends to focus on use rather than design. In general, there is incomplete scholarship on the subject of indigenous African boatbuilding traditions

Nevertheless, European traveler accounts do provide some basis for the variety of dugout designs that occurred across Africa during the slave trade. Both Lynn Harris (2014) and Robert Smith (1970) have summarized the notes and observations of myriad travelers through West Africa during this period, and present numerous similarities across accounts and vessel types. Although African dugouts vary wildly in size and purpose, most travelers describe them as being pointed on both ends of the hull, thereby demonstrating a canoe shape very different from *Bessie*. Smith notes (1970:519-520) that most modern vessels are built this way or with dovetail projections, and though he generalizes about the lack of design changes there is not strong evidence to suggest he is wrong in terms of the hull shape. Both Smith (1970:519-520) and Harris (2014:48) include different accounts of construction of African dugouts, which involved a combination of burning and scraping until the proper interior shape was achieved. These accounts describe the ends as either rounded off, or sharply pointed as can be found on most

dugouts. None of the described vessels bear more than minor resemblance to the complete hull shape (particularly the wineglass-shaped stern) of *Bessie*. These authors also describe various details on different vessels, which could include thwarts, stools, platforms, small decks, or even cabins, but at no point are frames of any kind mentioned. Bulkheads do feature in one construction process for larger boats (Smith 1970:520), but these are removed when hull sections are joined together. Michael Alford surmises (1992: 201) that African boatbuilding traditions probably played at most an indirect role in the design of logboats like *Bessie*.¹⁶ While it is theoretically possible that African woodworking traditions could have impacted the evolution of South Carolinian carpentry and the later generations of slaves trained in it, there is no archaeological or physical evidence on *Bessie* that shows African boatbuilding contributed to the design or form of this style of plantation boat.

The indigenous peoples of South Carolina had a more direct role in the maritime culture of the lowcountry. Lynn Harris discusses (2014:3-8) the extensive reliance that European settlers had on indigenous peoples and their watercraft during the colonial and pre-colonial periods. Native Americans helped the early settlers navigate the waterways, establish trade networks, and learn to hunt and fish in their new habitat. They were often hired to be guides, boatmen, or hunters for Europeans, and there was extensive trade between the groups throughout the colonial period and beyond. Essentially, Europeans relied heavily on indigenous peoples for boating knowledge and labor throughout the earlier eras of contact. This early contact during the acclimatization of settlers undoubtedly demonstrated the usefulness of canoe-boats and dugouts in this area, but Europeans had also been using dugouts and canoes for many centuries in their rivers and coastal regions (McGrail 2001:174-179). There are also still notable differences

¹⁶ Note that Alford is specifically referencing split-log canoes, but the same principles and arguments apply to single log vessels.

between indigenous craft and *Bessie*. Henry Glassie summarizes (1972:154-6) various studies of indigenous peoples from this region to note that the vast majority of pre-settlement indigenous watercraft featured rounded or blunted ends that raised up out of the water. They were built similarly to African craft with a combination of controlled burning and carving, and could also be hugely different in size and purpose, but showed different hull-design features than seen on *Bessie*. Although indigenous peoples played an important role in the early days of European boating culture in South Carolina, it does not appear that their vessels or traditions had any concrete impact on the later design of plantation boats like *Bessie*. The boats bear a similarity in that they are dugouts crafted from large local logs, but otherwise appear very different in construction and eventual form.

Europeans have also been building dugout vessels for several thousand years, and so French Huguenot or English settlers could easily have brought their own design ideas with them to the Carolinas. Logboat finds from Europe have been studied extensively by various authors (McGrail 1978a; McGrail 1978b; Reith 1985; Heal and Hutchinson 1986; McGrail 1987; McGrail 1988; McGrail 1990; Weski 2005), and though most of listed examples are ancient vessels that bear little resemblance to *Bessie*, the plantation boat form is immediately recognizable in European boats. Sometimes the best answer is the simplest, and in the case of *Bessie* a cursory look at the hull shape is most reminiscent of European small craft generally associated with planked vessels. Although John Michael Vlach (1978:101) is incorrect in some of his nautical details and in arguing that *Bessie*'s construction had more to do with Caribbean influences than European, he is correct in suggesting that a naval launch is a better comparison for *Bessie* than other logboats or canoes. Howard Chapelle (1951:12-28) describes a number of European small boat styles that were utilized in the early colonization of the Americas, and

provides lines for many of them. Although there are small differences, several of these vessels are extraordinarily similar to *Bessie*. Although early European dugouts tend to be very different in form and often feature almost square or U-shaped cross sections, they do actually feature precursors of the construction details that can be found in *Bessie*, but not in African or indigenous Carolinian vessels. Seán McGrail has compiled (1987) a list of logboat features along with the earliest recorded date in the European archaeological record. These features include the use of treenails to gauge the thickness of a hull being formed as early as 1100 B.C., and framing timbers inserted into the hull as early as A.D. 990. Although these features are by no means unique to European boatbuilding, they are not easily found in the archaeological record of the other possible contributing cultures.

Two more key aspects to consider are the local environment, and availability of materials. Jessica Lee Curci studied (2006:123-124) the impact of environmental conditions and the introduction of new tools on the form of logboats in this region in her dissertation, but found that there was no strong correlation between either the local environs or tools and eventual form. Instead, she found that intended use along with water conditions were the best indicators of hull form. Obviously building large dugout canoes would be impossible without large trees that can be hollowed out, but otherwise it is unlikely that *Bessie*'s shape was a direct result of the geographical environment.

Bessie is ultimately best described as a vernacular watercraft from the South Carolina lowcountry that bears some design resemblance to similar European vessels. Lynn Harris (2014) presents a compelling argument for the development of a creole maritime culture in South Carolina, but the physical evidence does not support the idea that this type of vessel is the result of cultural intermixing. While African boatbuilding traditions imported with earlier generations

of slaves undoubtedly could have affected South Carolinian boat design, there is no direct evidence of those traditions in *Bessie*. While indigenous peoples played an important role in helping early settlers adapt to their new maritime landscape, there is no evidence that this history directly resulted in any aspect of *Bessie*'s design. Although he is describing a different form of vessel, Henry Glassie (1972:168) describes the challenge and danger of looking for cultural influence in an artifact:

The ideal of completeness requires a full description of form: if one sees only the American log canoe's dugoutness it may be explained simply as a survival of an Indian craft; if one sees only its double-endedness it may be explained as a survival of European design. In reality form is a complex structure of components and no part of it may be taken to stand for the whole; one step in artefactual analysis must involve no less than a full formal description.

Although there are numerous cultural reasons to suspect slaves or indigenous people could have influenced the form of *Bessie*, the artifact itself bears no evidence of this impact. African canoes were admired (Harris 2014:49-50) for their craftsmanship and ornamentation, but there are no direct parallels between documented African ornamentation and those found on *Bessie*. Indigenous peoples certainly demonstrated the practicality and even longevity of cypress dugouts for use in this region, but there is no aspect of *Bessie*'s form that can be directly linked to the cultural connections in the colonial era. The use of local baldcypress as a rot resistant wood (Forest Products Laboratory 2001:1-10) is perhaps the only aspect of *Bessie* that could not have come directly from Europe, but colonists could certainly have learned how to select appropriate

materials from their own history of boatbuilding. It is certainly possible that there are cultural skills and practices that contributed to the craftsmanship and design of boats such as *Bessie*, but there is no hard evidence of anything but European design in the resulting form of the artifact.

Interpreting Digital *Bessie* in an Historical Context

As has been discussed, there are documentary records detailing how boats like *Bessie* were used and treated on South Carolina rice plantations. The variety of journals, letters, and documents left by the Manigault family has established a framework for how to think of *Bessie* in a cultural context. Nevertheless, the model allows one to re-examine these ideas, and explore the practical use of plantation boats from a technical perspective. While there are still limits as to the accuracy of performance data from the model, the general conclusions and observations made throughout the modeling process can add a practical element to the documentary narrative.

One of the baseline conclusions from the documentary evidence is that *Bessie* was not used as a cargo carrier, or designed to be primarily a working vessel as part of the functionality of the plantation. The archaeological findings support this idea, with the caveat that *Bessie* seems more capable of carrying cargo than initially suspected. The basic construction still does not suggest that capacity was a primary concern of the design. Michael Alford has demonstrated (1992) that split log canoes had a much higher capacity for cargo, and though construction would be more complicated, it would be very feasible to increase the beam and therefore capacity of the vessel built from a *Bessie* sized log. Similarly, there is no effort on *Bessie* to increase the freeboard outside of a caprail and washstrakes that only run part of the length of the hull. Other similar vessels have been documented to use this technique, possibly including

Accommodation.¹⁷ The fact that no effort seems to have been made to increase the carrying capacity of *Bessie* suggests that it was at best a secondary concern to the boat builder. The coefficients for the hull shape also support the fact that *Bessie* was not designed to maximize useable space.

However, as noted the cargo capacity determined by Orca 3D is far higher than the author initially expected. While the ambiguity concerning the hull moisture level makes accurate calculations difficult, even the heaviest estimates allowed *Bessie* to theoretically carry 1500 kg of weight in addition to 12 persons of 70 kg each. This condition resulted in so little freeboard as to make this scenario unlikely, but a smaller crew and somewhat less cargo is entirely realistic. Even with the heavy hull and a crew of 6 with a cargo load of over 700 kg, the vessel would be fairly stable. This may not be a large load for economic purposes, but it is certainly a lot more than mere recreational equipment or travelers' baggage. The floor timber tops also appear suitably flat in that area to have accommodated temporary ceiling planking. Although it still seems like a small vessel to go out on the ocean to modern sensibilities, the higher freeboard and stability with small cargo loads suggest that it may have performed okay in calmer seas along the coastal regions. The tests done here also did not account for the centerboard and the lower number of crew needed for sailing. Some configurations of the vessel would certainly have been more adequate for leaving the river than others.

Being able to leave the Santee in some form might have allowed for different recreational pursuits, but the stability issues might have left others out of reach. Chasing the elusive "devilfish," which seemed to be a popular sport among certain segments of the planter class

¹⁷ Both Fleetwood (1995:112) and Harris (2014:72) suggest that freeboard was intentionally added to *Accommodation*, but Brown, Cooper, and Harris found that this is likely a later museum repair that may or may not reflect a desire to raise freeboard by the original builders.

(Elliot 1994:17-18, 26-35), required an oceangoing vessel with several oars, and success in fishing would require the capacity to carry a very heavy fish home. It seems unlikely that *Bessie* would be suitable for open water fishing of this nature given the stability problems with lots of rowers and a potentially large cargo. The recording team speculated (Stewart et al. 2012) that *Bessie's* general lack of freeboard would make ocean travel improbable in inclement conditions, and the data reinforces this conclusion. Lynn Harris does (2014:70) note that the hull shape implies *Bessie* has use as an oceangoing or at least coastal boat, and this could correlate to the better stability with smaller loads or with use of the centerboard. Further testing with adverse weather conditions programmed into Orca 3D or with the centerboard modeled down could help better establish this likelihood.

The hull design supports the idea that *Bessie* was designed to be fast, and the coefficients seem to confirm that. *Bessie* has a length-to-beam ratio of nearly four to one, which is generally an indicator of efficient travel through the water. The block, midship, and prismatic coefficients suggest that *Bessie* could be quite swift, especially when riding higher in the water without a lot of passengers or cargo. This is consistent with the historical notes about boat racing. William Fleetwood contends (1995:113-121) that plantation boat racing was popular enough to eventually inspire custom designed racing canoes for use in Charleston Harbor. Gabriel Manigault also alludes to the importance of speed several times in his journal when referencing a spontaneous boat race, and comparing the performance of his vessel to that of a neighbor (Peter Manigault Collection 1856b:10 March 1858; Peter Manigault Collection 1840:3 March 1841). Speed was thus highly valued in plantation boats both in the documentary and archaeological records. The lack of stability and capacity is a natural consequence of that valuation.

Perhaps the most subtle result of the reconstruction is an appreciation for the skill and

care that went into the crafting of *Bessie*. There are some obvious decorative features such as the beadwork present on the rub rail and thwarts, but there are subtler features as well. In terms of detailing, even the cheek pieces near the bottom of the centerboard trunk (used to support the thwarts in that area) feature fileted edges and beadwork. These are relatively unimportant pieces hidden in an area that few would see, and yet are still crafted with decoration. The repairs to the hull are for the most part masterfully done. Anyone who has worked with wood has an appreciation for the difficulty of getting it to conform to exactly the desired shape, and the boat builders in this case were able to fit various pieces into odd shaped problem areas of the hull, and still make the exterior and interior surfaces conform to the overall shaping. Even the imperfections and oddities speak to the craftsmanship. The flatter section alluded to on the port bow area reminds the researcher of how the complexity of the hull shape was hand carved. There are imperfections, but they serve to highlight the skill required to form a complex hull shape. Perhaps they used a half-hull as a guide, perhaps they had a drawing, or perhaps they simply went by hand, but regardless it is an impressive feat of woodworking. The framing is similar. Each piece was exquisitely difficult to model in Rhinoceros, largely because each piece is entirely unique. Every frame had to fit exactly within the confines of the hand-carved interior shape of the hull, and had to be uniquely designed to fit over the unique floor timber, and around or through the unique thwart, and so on. In short, the process of reconstruction highlights the skill required to hand carve this entire vessel. Seeing *Bessie* is impressive, but building *Bessie* is to appreciate the skill of the carpentry. There is no shortage of pieces that the original builders were able to fit together better than this reconstructor could ever hope to do.

All of this craftsmanship points to skill in construction, and pride in the vessel. This was not a boat that was thrown together by amateurs or utilitarian in purpose, it was a boat that was

well maintained and cared for. When they beaded the edges, they did much more than strictly necessary for practical purposes. When they repaired the log, they wanted to maintain the sleek form of the hull and the efficient qualities of the craft. Planters would want to show off both the quality of their vessel, and by implication the quality of their craftsmen. Although *Bessie* does not feature anything quite like this, *Accommodation* had the family name “Hinson” stenciled into the transom (Harris 2014:72); one can imagine this functioning almost like a vanity plate of today, ensuring that anyone admiring the vessel would know to whom it belonged. Numerous authors have suggested that cypress canoe boats were inexpensive compared to planked vessels of the time, but it seems likely that status was relevant as well. Anybody with some money could buy a planked vessel in Charleston or probably several other port towns, but by the 1850s a canoe boat would likely signify that one was a planter. They could certainly be bought and sold like anything else (the Hinson family was not the original owner of *Accommodation*), but part of their value for some owners certainly derived from the pride of ownership for a vessel built entirely by one’s own resources on one’s own plantation. As noted by the Forest Products Laboratory handbook (2001:1-10), old growth cypress trees are all but gone today, and their scarcity would also probably have started to become relevant by the 1850s. The skillset to build *Bessie* today is rather rare, but finding the tree would likely be impossible. At some point in the last 150 years, any functioning plantation boats of this type would have become extraordinarily difficult to find, and that much more of a status symbol for anyone who still had the ability to sail one.

Simon Bronner (1985) has written about the importance of craftsmanship in an increasingly industrialized world. Building *Bessie* as a dugout logboat in the 1850s was a conscious choice, and every detail from the hull shape to the beadwork represents the investment

of both the owner and craftsman in the project. To look at *Bessie* is to appreciate the quality of design, but the process of trying to remake it emphasizes the skill of the craftsmanship. There is virtually nothing in the United States that is handmade to this size or degree in the twenty-first century. Taking this craftsmanship into account, it is worth considering *Bessie* as a superartifact as defined by Robert Ascher (1982). *Bessie* was not just a form of transportation, a toy for recreation, or a practical tool for getting around a water bound environment. *Bessie* is a handmade symbol of the plantation culture of South Carolina, and a showpiece of artisanship. *Bessie* is a point of pride for slave craftsmen and rowers, and a visible symbol of easy gentility for the Manigault family. There are many aspects of *Bessie*'s construction and function that are practical and useful for plantation life, but as an artifact, and particularly a handmade artifact, *Bessie* represents far more than the utilitarian function that could be ascribed to the dozens of other watercraft present on virtually any plantation on the Santee River. Henry Glassie notes (1972:167) that in aggressive cultures artifacts increasingly represent ideas and values more than responses to environment. *Bessie* is an excellent example of this. A similar logboat built a hundred years earlier might have been a practical vessel built from the best available materials to facilitate transportation and trade. But in the 1850's, *Bessie* could fulfill the same functions while making a statement about the values of the Manigault family, and the resources of White Oak Plantation.

Conclusions and Future Work

Perhaps the simplest practical purpose of creating a digital model of a vessel like *Bessie* is the chance to share it with others in a way that would otherwise be impossible. While the vessel is on display in Charleston, it is a seldom visited artifact tucked away in a rather hot and

humid courtyard of the museum. Even if one is to visit, few of the details discussed throughout this project are visible or evident without the opportunity to crawl around, look within, and engage the artifact in a way that would get most people ejected from the premises. A digital model allows for so much more than that. One cannot appreciate the artifact in the same emotional way, but it is far easier to explore the construction method, look at the shaping of the parts, and isolate individual points of interest. The availability of layers in the model allows both a researcher and student the opportunity to view different subsets of the structure from perspectives impossible with the actual artifact. Figures 14, 15, and 16 in the previous chapter each demonstrate this capability.

While the primary goal of this reconstruction was to explore the utility of this methodology for better understanding plantation culture, any good archeological fieldwork should involve a public outreach component to help promote the goals of conservation and educate the public on the subject matter. In many ways, a digital model is ideal for doing so. In the case of *Bessie*, the model will be offered to the Charleston Museum as well as the Program in Maritime Studies at East Carolina University for the purposes of education and outreach. It is hoped that the museum can utilize the model on their website, or in whatever medium is found useful to make *Bessie* and the rich cultural heritage it represents an easily accessible resource for the greater Charleston area.

In terms of the methodology, this project has shown that there is great potential for what can be accomplished with digital reconstruction through total station recording and Rhinoceros modeling, but also limitations and areas that require further study. The modeling process can be further refined as archaeologists learn to use the software more effectively, and can resolve the complications of trying to reverse engineer an artifact within a design program. Orca 3D holds

even more potential, but is equally challenging to use for this purpose. A greater understanding of how the program uses a model, or what requirements need go into the preparation of a model to be used effectively could help unlock several features that were never able to function properly with digital *Bessie*. In particular, Orca 3D enables testing stability and hull efficiency at different speeds with different load conditions for a displacement hull. It would be very interesting to see how *Bessie* or other historical vessels could perform, and get a better sense of how effective their designs were for different purposes. Similarly, the ability to subject the model to different wind and wave conditions would increase our understanding of the likely operating environment of the vessel in question. This could also better elucidate *Bessie*'s oceangoing capacity. Some of these features may simply require more work in Orca 3D to determine how they can best function with the *Bessie* model, but others seem to require a model built with different parameters to run the tests correctly.

In addition to the ability to run these further tests on *Bessie*, there are more opportunities for learning about the specific construction process used and the sailing rig that was deployed on this plantation boat. Dr. David Stewart of East Carolina University is currently working on an article originally began by the recording team (Stewart et al. 2012) that will both provide a more detailed technical description of *Bessie*, and explore possible rigs for the sailing configuration. It is hoped that this data in conjunction with Orca 3D will provide a more complete picture of *Bessie*'s capabilities. Another area of potential research is the fasteners and bungs spread throughout the vessel. As has been noted, this project modeled the fasteners primarily to estimate the weight they would contribute for the performance testing, but the recording strategy was not designed for extensive analysis of patterns and use. The bungs are similar, and a project to fully document these would allow for better analysis of the construction process, and interpretation of

how that might compare to other dugouts built with gauge holes for hull thickness.

The point-location issues encountered while modeling highlight the biggest methodological lesson from this project: although this method of recording is capable of tremendous accuracy, the value in this is equally dependent on the precision of the recording team. In the case of *Bessie*, the flaws within the data set severely undermined the accuracy of the digital model. Although *Bessie* is relatively stable and available for further analysis, this will not be the case for all artifacts. Great care should be taken to record accurate data especially when recording sites that are in danger of deterioration or slated for outright destruction. This process has the potential to unlock data about vessels that have never been easily available with previous methodologies. That being said, the time and resources required to both capture and process the data warrant the constant refining of techniques and quality control to ensure the worthwhileness of the project and the validity of the results.

REFERENCES

Alford, Michael B.

1992 Origins of Carolina Split-Dugout Canoes. *The International Journal of Nautical Archaeology* 21(3): 191-203.

Alston, J. Motte

1953 *Rice Planter and Sportsman: The Recollections of J. Motte Alston, 1821-1909*. University of South Carolina Press, Columbia, SC.

Ball, Edward

1998 *Slaves in the Family*. Ballentine Books, New York, NY.

Barnes, L. Diane

2008 *Artisan Workers in the Upper South: Petersburg, Virginia 1820-1860*. State University Press, Baton Rouge, LA.

Bass, George F., and Frederick H. Van Doorninck (editors)

1982 *Yassi Ada: A Seventh-Century Byzantine Shipwreck*. Volume I. Texas A&M University Press, College Station, TX.

Bass, George F., Sheila D. Matthews, J. Richard Steffy, and Frederick H. van Doorninck Jr. (editors)

2004 *Serçe Limani: An Eleventh Century Shipwreck*. Volume I. Texas A&M University Press, College Station, TX.

Bell, Malcolm Jr.

1987 *Major Butler's Legacy: Five Generations of a Slaveholding Family*. The University of Georgia Press, Athens, GA.

Bronner, Simon J.

1985 Visible Proofs: Material Culture Study in American Folkloristics. In *Material Culture: A Research Guide*, Thomas J. Schlereth, editor, pp. 127-154. University of Kansas Press, Lawrence, KS.

1986 *Grasping Things: Folk Material Culture and Mass Society in America*. The University Press of Kentucky, Lexington, KY.

Brown, Daniel, Kathryn Cooper, and Lynn Harris

2011 The Plantation Boat *Accommodation*: The Historical and Archaeological Investigation of the Maritime Icon of the South, Part 1. *Nautical Research Journal* 56(2): 93-114.

Byrne, William A.

1993 The Hiring of Woodson, Slave Carpenter of Savannah. *The Georgia Historical Quarterly* 77(2): 245-263.

Cecelski, David S.

2001 *The Waterman's Song: Slavery and Freedom in Maritime North Carolina*. The University of North Carolina Press, Chapel Hill, NC.

Chapelle, Howard I.

1951 *American Small Sailing Craft: Their Design, Development, and Construction*. W. W. Norton & Company, New York, NY.

Charleston Museum

1926 Accession Materials Related to Plantation Boat "The Bessie." Charleston Museum. 1926.252.

Coates, John, Seán McGrail, David Brown, Edwin Gifford, Gerald Grainge, Basil Greenhill, Peter Marsden, Boris Rankov, Colin Tipping, and Edward Wright

1995 Experimental Boat and Ship Archaeology: Principles and Methods. *The International Journal of Nautical Archaeology* 24(4): 293-301.

Crouse, Maurice Alfred

1964 The Manigault Family of South Carolina. Dissertation. Northwestern University, Evanston, IL.

Crumlin-Pedersen, Ole, and Seán McGrail

2006 Some Principles for the Reconstruction of Ancient Boat Structures. *The International Journal of Nautical Archaeology* 35(1): 53-57.

Crumlin-Pedersen, Ole

2006 The Dover Boat – a Reconstruction Case-Study. *The International Journal of Nautical Archaeology* 35(1): 58-71.

Csikszentmihaly, Mihaly

1993 Why We Need Things. In *History From Things: Essays on Material Culture*, Steven Lubar and W. David Kingery, editors, pp. 20-29. Smithsonian Institution Press, Washington, DC.

Curci, Jessica Lee

2006 *Logboats of the Southeastern United States: Investigating the Question of Form*. Doctoral Dissertation, Department of Coastal Resources Management, East Carolina University. University Microfilms International, Ann Arbor, MI.

Deetz, James

1977 *In Small Things Forgotten: An Archaeology of Early American Life*. Anchor Books, New York, NY.

Doar, David

1936 *Rice and Rice Planting in the South Carolina Low Country*. Charleston Museum, Charleston, SC.

Douglass, Frederick

- 2002 *My Life in Bondage and My Freedom*. Humanity Books, Amherst, NY.
- Eisterhold, John A.
1973 Charleston: Lumber and Trade in a Declining Southern Port. *The South Carolina Historical Magazine* 74(2): 61-72.
- Elliot, William
1994 *Carolina's Sports by Land and Water: Including incidents of Devil-Fishing, Wild-Cat, Deer & Bear Hunting, Etc.* University of South Carolina Press, Columbia, SC.
- Falck, Eberhard
2014 Boats and Boatbuilding in Tanzania (Dar-es-Salaam and Zanzibar). *The International Journal of Nautical Archaeology* 43(1): 162-173.
- Ferguson, Leland
1992 *Uncommon Ground: Archaeology and Early African America, 1650-1800*. Smithsonian Books, Washington, DC.
- Fleetwood Jr., William C.
1995 *Tidecraft: The Boats of South Carolina, Georgia, and northeastern Florida, 1550-1950*. WBG Marine Press, St. Augustine, FL.
- Forest Products Laboratory
2001 *Wood Handbook – Wood as an Engineering Material*. General Technical Reports FPL-GTR-113. U.S. Department of Agriculture, Washington DC.
- Friedel, Robert
1993 Some Matters of Substance. In *History From Things: Essays on Material Culture*, Steven Lubar and W. David Kingery, editors, pp. 41-50. Smithsonian Institution Press, Washington, DC.
- Glassie, Henry
1972 The Nature of the New World Artifact: The Instance of the Dugout Canoe. *Schweizerisches Archiv für Volkskunde* 68-69: 153-170.
1999 *Material Culture*. Indiana University Press, Bloomington, IN.
- Google
2013 Google Earth v. 7.0.3.8542. Accessed 25 Feb. 2013.
- Grainge, Gerald
2012 Sailing a Sinhalese Outrigger Logboat. *The International Journal of Nautical Archaeology* 41(1): 158-170.
- Greene, Jack P.
1987 Colonial South Carolina and the Caribbean Connection. *The South Carolina Historical Magazine* 88(4): 192-210.

Harris, Lynn

1997 Public Education and Submerged Small Craft Documentation in South Carolina. *Museum Small Craft Association Transactions* 3: 46-54.

1998 Canoes and Canoe-built Vessels in the Low Country. *Occasional Maritime Research Papers*. Maritime Research Division, South Carolina Institute of Archaeology and Anthropology, USC.

2002 Recording of Another Dugout Canoe! *Legacy* 7(1): 4-5.

2014 *Patroons and Periaguas: Enslaved Watermen and Watercraft of the Lowcountry*. Studies in Maritime History. The University of South Carolina Press, Columbia SC.

Heal, S. V. E., and Gillian Hutchinson

1986 Three Recently Found Logboats. *The International Journal of Nautical Archaeology* 15(3): 205-213.

Hocker, Frederick M.

1991 *The Development of a Bottom-Based Shipbuilding tradition in Northwestern Europe and the New World*. Doctoral Dissertation, Department of Anthropology, Texas A&M University. University Microfilms International, Ann Arbor, MI.

2004 Shipbuilding: Philosophy, Practice, and Research. In *The Philosophy of Shipbuilding: Conceptual Approaches to the Study of Wooden Ships*, Frederick M. Hocker and Cheryl A. Ward, editors, pp. 1-12. Texas A&M University Press, College Station, TX.

Jones, A. M.

1971 *Africa and Indonesia: The Evidence of the Xylophone and other Musical and Cultural Factors*. E. J. Brill, Netherlands.

Jones, Michael Owen

1993 Why Take a Behavioral Approach to Folk Objects? In *History From Things: Essays on Material Culture*, Steven Lubar and W. David Kingery, editors, pp. 182-196. Smithsonian Institution Press, Washington, DC.

Joyner, Charles

1984 *Down by the Riverside: A South Carolina Slave Community*. University of Illinois Press, Urbana, IL.

Kingery, W. David (editor)

1996 *Learning from Things: Method and Theory of Material Culture Studies*. Smithsonian Institution Press, Washington, DC.

Kristiansen, Kristian

1996 The Destruction of the Archaeological heritage and the Formation of Museum Collections. In *Learning from Things: Method and Theory of Material Culture Studies*, David W. Kingery, editor, pp. 89-101. Smithsonian Institution Press, Washington, DC.

Lachicotte, Alberta Morel

1955 *Georgetown Rice Plantations*. The State Printing Company, Columbia, SC.

Lander Jr., Ernest M.

1951 Ante-Bellum Milling in South Carolina. *The South Carolina Historical and Genealogical Magazine* 52(3): 125-132.

1960 Charleston: Manufacturing Center of the Old South. *The Journal of Southern History* 26(3): 330-351.

Lemée, Christian P.P.

2006 *The Renaissance Shipwrecks from Christianshavn: An Archaeological and architectural study of large carvel vessel in Danish waters, 1580-1640*. Roskilde, Denmark.

Library of Congress

2001 *Born in Slavery: Slave Narratives from the Federal Writers' Project, 1936-1938*.

Manuscript Division, Library of Congress <memory.loc.gov/ammem/snhtml/snhome.html>.

Accessed 26 May 2013.

Linder, Suzanne Cameron and Marta Leslie Thacker

2001 *Historical Atlas of the Rice Plantations of Georgetown County and the Santee River*. South Carolina Department of Archives and History, Columbia, SC.

Littlefield, Daniel C.

1991 *Rice and Slaves: Ethnicity and the Slave Trade in Colonial South Carolina*. University of Illinois Press, IL.

Lubar, Steven

1993 Machine Politics: The Political Construction of Technological Artifacts. In *History From Things: Essays on Material Culture*, Steven Lubar and W. David Kingery, editors, pp. 197-214. Smithsonian Institution Press, Washington, DC.

Lubar, Steven, and W. David Kingery (editors)

1993 *History From Things: Essays on Material Culture*. Smithsonian Institution Press, Washington, DC.

Maarleveld, Thijs J.

1995 Type or Technique. Some thoughts on boat and ship finds as indicative of cultural traditions. *The International Journal of Nautical Archaeology* 24(1):3-7.

Mallard, R. Q.

1892 *Plantation Life Before Emancipation*. Whittet & Shepperson, Richmond, VA.

Mandell, Richard D.

1984 *Sport: A Cultural History*. Columbia University Press, New York, NY.

Manigault, Arthur Middleton

1983 *A Carolinian Goes to War*. R. Lockwood Tower, editor. University of South Carolina Press, Columbia, SC.

Manigault Jr., Edward Lining

2007 *The Manigault Family of South Carolina, Its Ancestors and Descendants*. Self-published.

Manigault Family Papers

1971 Manigault Family Papers, 1685-1971, 1068.00. South Carolina Historical Society, Charleston, SC.

Maquet, Jules

1993 Objects as Instruments, Objects as Signs. In *History From Things: Essays on Material Culture*, Steven Lubar and W. David Kingery, editors, pp. 30-40. Smithsonian Institution Press, Washington, DC.

McGrail, Seán

1978a *Logboats of England and Wales with Comparative Material from European and Other Countries. Part i: Discussion and Catalogue*. National Maritime Museum, Archaeological Series No. 2, BAR British Series 51 (i). Greenwich, England.

1978b *Logboats of England and Wales with Comparative Material from European and Other Countries. Part ii: Drawings and Illustrations*. National Maritime Museum, Archaeological Series No. 2, BAR British Series 51 (ii). Greenwich, England.

1987 Early Boatbuilding Techniques in Britain and Ireland – Dating Technological Change. *The International Journal of Nautical Archaeology and Underwater Exploration* 16(4): 343-354.

1988 Assessing the Performance of an Ancient Boat – The Hasholme Logboat. *Oxford Journal of Archaeology* 7(1): 35-46.

1990 The Theoretical Performance of a Hypothetical Reconstruction of the Clapton Logboat. *The International Journal of Nautical Archaeology and Underwater Exploration* 19(2): 129-133.

1992 Replicas, Reconstructions and Floating Hypothesis. *The International Journal of Nautical Archaeology* 21.4: 353-355.

2001 *Boats of the World: From the Stone Age to Medieval Times*. Oxford University Press, Oxford, UK.

McGrail, Seán and Ole Crumlin-Pederson

2006 Some Principles for the Reconstruction of Ancient Boat Structures. *The International Journal of Nautical Archaeology* 35(1): 53-57.

Naylor, Carl

2010 *The day the johnboat went up the mountain: Stories from my twenty years in South Carolina maritime archaeology*. The University of South Carolina Press, Columbia, SC.

Newton, James E.

1977 Slave Artisans and Craftsmen: The Roots of Afro-American Art. *The Black Scholar* 9(3): 35-42.

Newton, James E. and Ronald L. Lewis (editors)
1978 *The Other Slaves: Mechanics, Artisans and Craftsmen*. G. K. Hall & Co., Boston, MA.

Nichols, Patricia Causey
2009 *Voices of our Ancestors: Language Contact in Early South Carolina*. The University of South Carolina Press, Columbia, SC.

Peirce, Benjamin (editor)
1873 US Coast Survey: Winyah Bay and Santee Rivers, South Carolina, 1873. Map. NOAA Historical Map and Chart Collection.<historicalcharts.noaa.gov> Accessed 14 November 2012.

Pennington, Patience
1961 *A Woman Rice Planter*. Harvard University Press, Cambridge, MA.

Pereira, Duarte Pacheco
1937 *Esmeraldo de Ditu Orbis*. Translated by George H. T. Kimble. The Hakluyt Society, London.

Peter Manigault Collection

1824 Charlotte Drayton Manigault Journal 1824-1855, 436-01-01-07-03, Box 3, Peter Manigault Collection, 1745-ca., South Carolina Historical Society, Charleston, SC.

1840 Gabriel Manigault Journal 1840-1842, 1950 typescript, 436.01.01.13-05, Peter Manigault Collection, 1745-ca., South Carolina Historical Society, Charleston, SC.

1843 Joseph Manigault Estate Papers, 435.01.01.16-05, Peter Manigault Collection, 1745-ca., South Carolina Historical Society, Charleston, SC.

1845 Gabriel Manigault Journal 1845-1846, 436-01-01-13-06, Box 5, Peter Manigault Collection, 1745-ca., South Carolina Historical Society, Charleston, SC.

1856a Division of Joseph Manigault Estate, 435.01.01.16-05, Peter Manigault Collection, 1745-ca., South Carolina Historical Society, Charleston, SC.

1856b Gabriel Manigault Journal 1856-1858, 436-01-01-13-07, Box 5, Peter Manigault Collection, 1745-ca., South Carolina Historical Society, Charleston, SC.

1898 Lawsuit Concerning Creek Navigability, 436-01-01-05-11, Box 2, Peter Manigault Collection, 1745-ca., South Carolina Historical Society, Charleston, SC.

Peters, Kenneth E., and Robert B. Herrmann (editors)
1986 *First-hand Observations of the Charleston Earthquake of August 31, 1886, and Other Earthquake Materials*. Bulletin 41. South Carolina Geological Survey, Columbia, SC.

Phillips, Ulrich Bonnell

1918 *American Negro Slavery: A Survey of the Supply, Employment and Control of Negro Labor as determined by the Plantation Regime*. London D. Appleton and Co., New York, NY.

Powers Jr., Bernard E.

1994 *Black Charlestonians: A Social History, 1822-1885*. University of Arkansas Press, Fayetteville, AR.

Prown, Jules David

1988 Mind in Matter: An Introduction to Material Culture Theory and Method. In *Material Life In America, 1600-1860*, Robert Blair St. George, editor, pp. 17-37. Northeastern University Press, Boston, MA.

1993 The Truth of Material Culture: History or Fiction? In *History From Things: Essays on Material Culture*, Steven Lubar and W. David Kingery, editors, pp. 1-19. Smithsonian Institution Press, Washington, DC.

1996 Material/Culture: Can the Farmer and the Cowman Still be Friends? In *Learning from Things: Method and Theory of Material Culture Studies*, David W. Kingery, editor, pp. 19-27. Smithsonian Institution Press, Washington, DC.

Pursell, Jr., Carroll W.

1985 The History of Technology and the Study of Material Culture. In *Material Culture: A Research Guide*, Thomas J. Schlereth, editor, pp. 113-126. University of Kansas Press, Lawrence, KS.

Rieth, A. Marguet E.

1985 La Pirogue Médiévale de Massay (Cher) / The Medieval Logboat of Massay (Cher). *Revue Archéologique du Centre de la France* 24(1):35-51.

Rogers, Jr., George C.

1970 *The History of Georgetown County, South Carolina*. University of South Carolina, Columbia, SC.

Schiffer, Michael Brian

1996 Formation Processes of the Historical and Archaeological Records. In *Learning from Things: Method and Theory of Material Culture Studies*, David W. Kingery, editor, pp. 73-80. Smithsonian Institution Press, Washington, DC.

Schlereth, Thomas J.

1982 *Material Culture Studies in America*. Altamira Press, Walnut Creek, CA.

1985a Material Culture and Cultural Research. In *Material Culture: A Research Guide*, Thomas J. Schlereth, editor, pp. 1-34. University of Kansas Press, Lawrence, KS.

1985b Social History Scholarship and Material Culture Research. In *Material Culture: A Research Guide*, Thomas J. Schlereth, editor, pp. 155-196. University of Kansas Press, Lawrence, KS.

Schlereth, Thomas J., ed.

1985 *Material Culture: A Research Guide*. University of Kansas Press, Lawrence, KS.

Schweninger, Loren

1992 Slave Independence and Enterprise in South Carolina, 1780-1865. *The South Carolina Historical Magazine* 93(2): 101-125.

Smith, Alice R. Huger, Herbert Ravenel Sass, and D.E. Huger Smith

- 1936 *A Carolina Rice Plantation of the Fifties*. William Morrow and Company, New York, NY.
- Smith, Henry A. M.
1917 The Orange Quarter and the First French Settler in South Carolina. *The South Carolina Historical and Genealogical Magazine* 18(3): 101-123.
- Smith, Robert
1970 The Canoe in West African History. *The Journal of African History* 11(4): 515-533.
- Spivey, Donald (editor)
1985 *Sport in America: New Historical Perspectives*. Greenwood Press, Westport, England.
- Stampf, Kenneth M.
1956 *The Peculiar Institution: Slavery in the Ante-Bellum South*. Vintage Books, New York, NY.
- Stavisky, Leonard P.
1958 *The Negro Artisan in the South Atlantic States, 1800-1860: A Study of Status and Economic Opportunity with Special Reference to Charleston*. Doctoral Dissertation, Department of Political Science, Columbia University. University Microfilms International, Ann Arbor, MI.
- Steffy, Richard J.
1982a Reconstructing the Hull. In *Yassi Ada: A Seventh-Century Byzantine Shipwreck*, George F. Bass and Frederick H. Van Doorninck (editors), pp. 65-86. Volume I. Texas A&M University Press, College Station, TX.
1982b The Reconstruction of the 11th Century Serçe Liman Vessel: A Preliminary Report. *The International Journal of Nautical Archaeology and Underwater Exploration* 11(1): 13-34.
1989 The Role of Three-Dimensional Research in the Kyrenia Ship Reconstruction. In H. Tzalas, ed., *Tropis I: 1st International Symposium on Ship Construction in Antiquity*, pp. 249-262. Hellenic Institute for the Preservation of Maritime History, Athens, Greece.
1994 *Wooden Ship Building and the Interpretation of Shipwrecks*. Texas A&M University Press, College Station, TX.
- Steffy, Richard J., Sheila D. Matthews, Frederick M. Hocker, and Robin C. M. Piercy
2004 Reconstruction, Reassembly, and Display. In *Serçe Limani: An Eleventh Century Shipwreck*. George F. Bass, Sheila D. Matthews, J. Richard Steffy, and Frederick H. van Doorninck Jr. (editors), pp. 123-152. Volume I. Texas A&M University Press, College Station, TX.
- Stewart, David J., Nathaniel Howe, and Jeffrey O'Neill
2012 *Bessie: A Single-Log Plantation Boat from South Carolina* [draft 6]. Unpublished article as of November, 2012.
- Twining, Mary A.
1976 African-Afro-American Artistic Continuity. *Journal of African Studies* 2(4): 569-578.

Upton, Dell

1985 The Power of Things: Recent Studies in American Vernacular Architecture. In *Material Culture: A Research Guide*, Thomas J. Schlereth, editor, pp. 57-78. University of Kansas Press, Lawrence, KS.

Uya, Okon Edet

1971 *From Slavery to Public Service: Robert Smalls 1839-1915*. Oxford University Press, New York, NY.

Van Doorninck Jr., Frederick H.

1982 The Hull Remains. In *Yassi Ada: A Seventh-Century Byzantine Shipwreck*, George F. Bass and Frederick H. Van Doorninck (editors), pp. 32-64. Volume I. Texas A&M University Press, College Station, TX.

Vlach, John Michael

1976a The Shotgun House: An African Architectural Legacy. Part I. *Pioneer America* 8(1): 47-56.

1976b The Shotgun House: An African Architectural Legacy. Part II. *Pioneer America* 8(2): 57-70.

1978 *The Afro-American Tradition in Decorative Arts*. Cleveland Museum of Art, Cleveland, OH.

1981 Afro-American Folk Crafts in Nineteenth Century Texas. *Western Folklore* 40(2): 149-161.

1991 *By the Work of Their Hands: Studies in Afro-American Folklore*. UMI Research Press, Ann Arbor, MI.

Wade, Richard C.

1964 *Slavery in the Cities: The South 1820-1860*. Oxford University Press, New York, NY.

Wade, Richard C. (editor)

1965 *The Negro in American Life: Selected Readings*. Houghton Mifflin Company, New York, NY.

Weski, Timm

2005 Unfinished and Paired Logboats from Bavaria, Germany. *The International Journal of Nautical Archaeology* 34(2): 269-281.

Wiggins, David K.

1985 Leisure Time on the Southern Plantation: The Slaves' Respite from Constant Toil, 1810-1960. In *Sport in America: New Historical Perspectives*, Donald Spivey, editor, pp. 25-50. Greenwood Press, Westport, CT.

Wood, Peter H.

1974 *Black Majority: Negroes in Colonial South Carolina: From 1670 through the Stono Rebellion*. Alfred A. Knopf, New York, NY.

APPENDIX A – ADDITIONAL PHOTOS AND DRAWINGS OF *BESSIE*

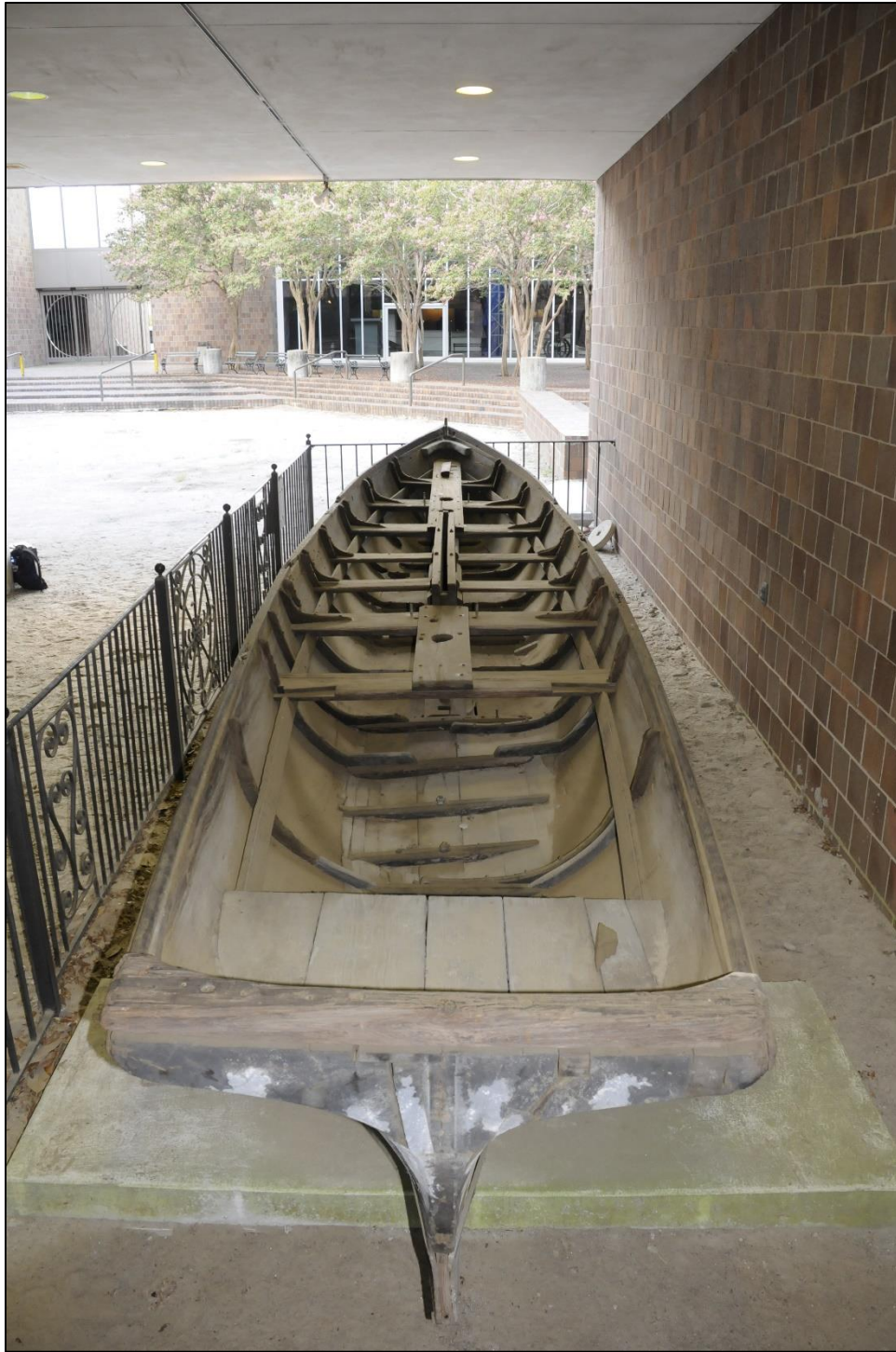

Figure 18: Stern View of *Bessie* Interior in Charleston Museum Courtyard (photo by ECU Fall Field School 2010)



Figure 19: *Bessie* in the Courtyard of the Charleston Museum (photo by ECU Fall Field School 2010)



Figure 20: *Bessie* View from Stern Quarter (photo by ECU Fall Field School 2010)



Figure 21: *Bessie* Starboard Bow Profile (photo by author 2012)

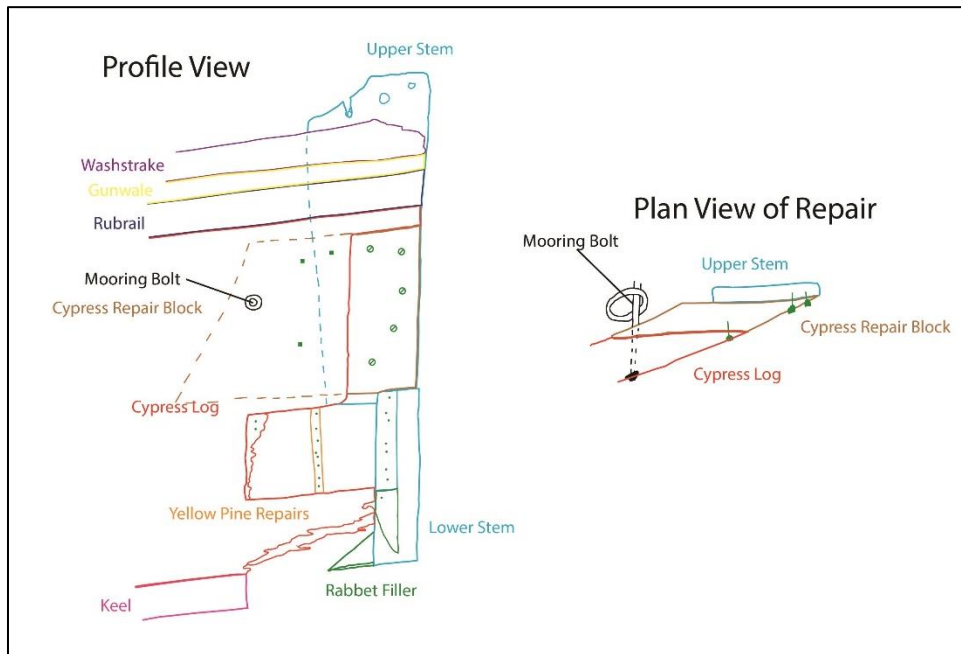

Figure 22: *Bessie* Starboard Bow Profile Detail Drawing (drawing by Nat Howe on ECU Fall Field School 2010, digitization by author 2011)



Figure 23: Close Up of Starboard Bow Construction (photo by author 2013)



Figure 24: *Bessie* Port Bow Profile (photo by ECU Fall Field School 2010)



Figure 25: *Bessie* Hull Bottom and Keel from Starboard side facing aft (photo by author 2013)



Figure 26: *Bessie* Starboard Hull facing forward (photo by author 2012)



Figure 27: *Bessie* Starboard Stern Profile (photo by author 2013)



Figure 28: *Bessie* Port Stern Profile (photo by author 2012)



Figure 29: *Bessie* Transom with Various Repairs (photo by author 2012)



Figure 30: *Bessie* Forward Interior Area (photo by ECU Fall Field School 2010)



Figure 31: *Bessie* Interior facing Aft from Bow (photo by author 2012)



Figure 32: *Bessie* Interior facing Forward from Stern Deck (photo by author 2012)



Figure 33: Close Up of Interior Bow and Breasthook from above the Mast Partner (photo by ECU Fall Field School 2010)



Figure 34: Close Up of Interior Bow and Repairs from below the Mast Partner (photo by author 2012)



Figure 35: Forward Mast Partner and Supporting Structures from Port Side (photo by ECU Fall Field School 2010)



Figure 36: Forward Mast Steps and Floor Timbers from Starboard Side (photo by author 2012)



Figure 37: Aft Mast Steps and Partner from Starboard Side (photo by ECU Fall Field School 2010)



Figure 38: Centerboard Trunk and Surrounding Structure looking forward from Port Side (photo by ECU Fall Field School 2010)



Figure 39: Thwart 1 Knees and Surrounding Structures (photo by ECU Fall Field School 2010)



Figure 40: Thwart 1 and Surrounding Structures from Above (photo by author 2013)



Figure 41: Thwart 2 and Surrounding Structures from Above (photo by author 2012)



Figure 42: Thwart 3 and Surrounding Structures from Above (photo by author 2012)



Figure 43: Thwart 4 and Surrounding Structures from Above (photo by author 2012)



Figure 44: Thwart 5 and Surrounding Structures from Above (photo by author 2012)



Figure 45: Thwart 6 and Surrounding Structures from Above (photo by author 2012)



Figure 46: Thwart 7 and Surrounding Structures from Above (photo by author 2012)



Figure 47: Stern Repair Area from Port Side (photo by author 2013)



Figure 48: Stern Repair Area looking Forward from Starboard Stern (photo by author 2012)



Figure 49: Stern Area with Various Repair Sections (photo by author 2012)

APPENDIX B – WHITE OAK PLANTATION MAPS AND PHOTO

The following maps were created by layering various maps (Peirce 1873, Lachicotte 1955) of the Georgetown rice growing region over satellite views generated by Google (2013) Maps to show the approximate location of White Oak plantation relative to Charleston and the Santee River.

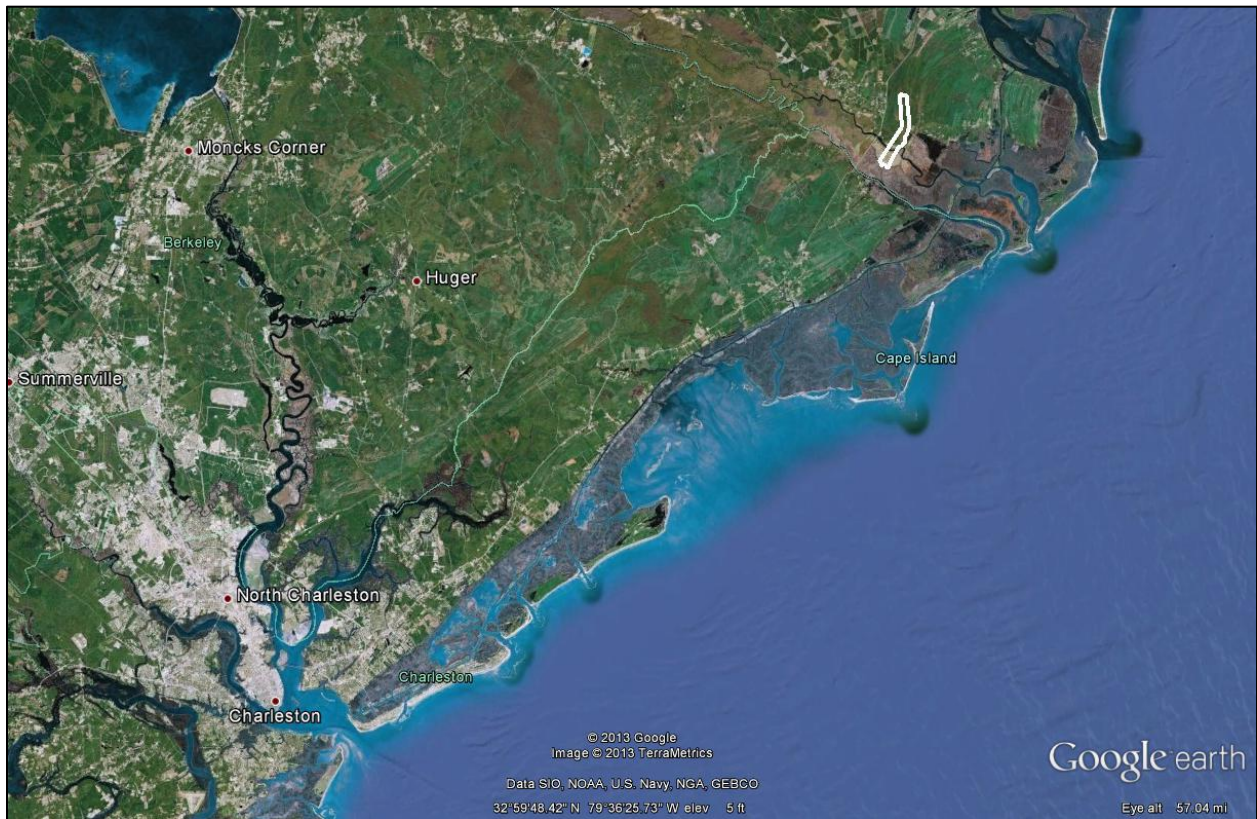

Figure 50: Satellite View of South Carolina Rice Country

Figure 18 shows Charleston, SC visible in the lower left, and White Oak Plantation outlined in White near the upper right corner. Georgetown, SC is not pictured, but sits on Winyah Bay in the very top right corner of the map.

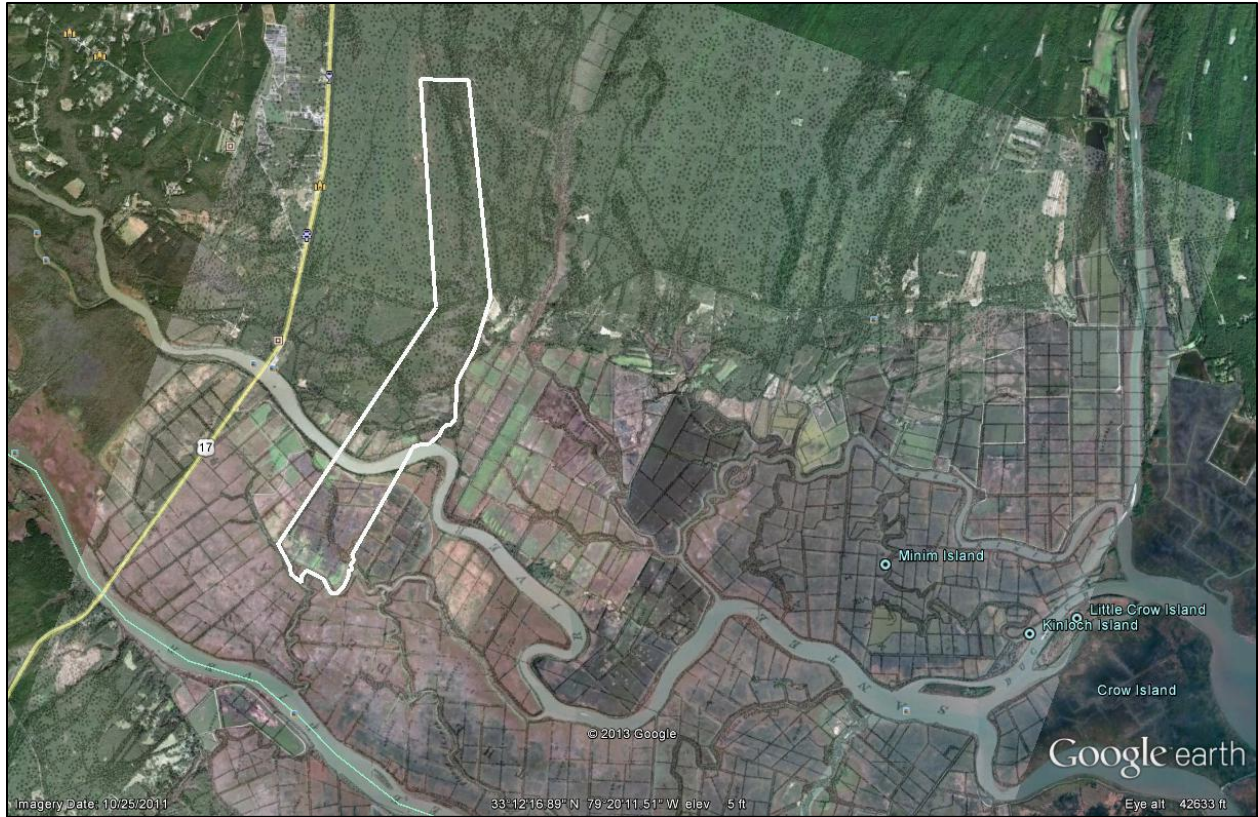

Figure 51: White Oak Plantation Straddling the North Santee River

White Oak Plantation is visible outlined in White in Figure 19 straddling the north fork of the Santee River. The overlay is an 1873 (Peirce) map of the region. Present day Highway 17 runs just to the left of the plantation.



Figure 52: Close-Up of White Oak Plantation with Fields and Creeks

Figure 20 is a close up view of the Peirce map (1873) overlaid on the Google (2013) satellite view of the area showing the fields that straddled the Santee. Note the label “White Oak Creek” visible on a creek running through the fields just south of the river. Not pictured here, a present day Google (2013) maps label identifies the creek on the north side of the river on the eastern edge of the white outline as “White Oak Creek” as well.



**Figure 53: North Santee River Roughly 1 Mile Upstream from White Oak Plantation Site
(photo by author 2012)**

Figure 53 was taken from a small boat dock where present-day Highway US-17 crosses the North Fork of the Santee River. The photo was taken from the North bank and is looking East towards where White Oak Plantation straddled the river, a little less than 1 mile from the current site of the highway bridge.

APPENDIX C – MODELING LOG

Notes on Rhino Usage

- Complex shapes
 - Once a wireframe exists, patch is very effective at creating complex surfaces over them. If the patch ends up too big, use the trim function with the original wireframe parameters to cut it to size. This works very well. The patch will have some error in the more complex sections. See next note
 - Once you have multiple patch surfaces, you can use the Surface edge tool join 2 naked edges to fix this. It will in fact in many cases move the edge of the surface back to where it should have been if the patch had fit better in the first place.
 - Was happy with the above strategy, but when working on port side I noticed this seem is still very angular. Doesn't have a nice curved shape like I want it to. Haven't figured out a way to fix this as of yet. The edges seem to get more angular when combined than either started
 - For recreating some lines that are either unknown or unshootable, I create lines on a similar distance or measure, and then recreate them to create a curve. Used this for distance for depth of rubrail to recreate hull line, also for curves under the stern section.
 - THOUGHT: Build a solid that is very close to accurate using the surfaces that come closest, like the outer hull being one large surface, and then trim it using more fine-tuned surfaces to get rid of annoying parts. It could work.
 - 4/16 instinct to start with the hull as they would have is good, but problematic. It's so complex it relies on all the things built into it to understand the full shape in terms of reverse engineering, so starting with it may not actually be as wise as I initially planned on. Finding the interior bow section needs to be cobbled together from several different things and shapes and points, and so starting with it as such a complex area is very difficult.
- Issues
 - Shooting on futtocks is very rough. Having to nudge a lot just to get them in a relatively straight line for building interior lines. Started creating new points for this purpose after first 1 or 2 frame stations in order to preserve original points for actual futtocks construction
 - Some points made very strange lines, had to make choices which were more likely accurate. See Port side futtocks 6 for example (4th futtock from bow)
 - Too much curve on the bottom of the interior hull lines. On SBFL 7, I added points to the curve in what represents a straight line along the bottom of the floor to make the curve flatter, but not with an angle from one curve to a straight section. Used in several other futtocks moving aft

- Not sure if I like my interior hull line drawn from SBFL 9 fwd face lower outside corner. I have two points on the corner in making the curve which should be fairly regular, and they are not. I think the newer point which should in more inboard is actually shown more outboard, and taking it out makes the curve much nicer. But then where did it shoot? What is it hitting? By my new line it would be hull there... Not entirely sure how to proceed.
 - Not using as many points on the topmost outboard edge points on floors, they seem to often not be right on the interior hull, but a little above.
 - At frame station 9, resolved by not using two points on the floor. No good photos, but the best I have seems to show a jagged edge there that may have been shot above hull. The difference in my line with the other would be about 1.5cm, very reasonable from the photo. The resulting bulge from not having more points might be a little wide though.
- Floors have often been labeled in different ways. Some have the prefix, MS, some have SB or BB, and some single floors have all 3 prefixes on one floor.
- Interior bow section is going to be almost entirely rebuilt. Will require lots of use of other points and lines to try to reconstruct something that looks like interior of hull. Using mostly exterior reconstruction, but also breasthook, mast partner, and average thickness to try to recreate. Pictures are key, and some things are just being built by looks and freehand
 - This is important for theory – how much liberty is too much in recreating? It is supposed to be a reconstruction so it's not going to be 100%, but it should be based on something – Dave and I spoke about this, but it's not a theory that has been completely established yet.
 - For front edge of interior SB bow, using mostly mast step which is very near the fwd edge of the hull. Will reconstruct on that.
 - Port side. Extended lines out along the edges of the mast step in order to find where the interior bow would be. Extended this point forward to the exterior edge. Used breasthook to set the vertical curve angle, and then cut off those vertical segments at same height as exterior hull.
 - Determined the interior bow point that meet by estimating position from maststep points and pictures. Built up to previous established points from there. Then adjusted the points to make sure they run on the outside of the stem from lines dropped from the aft side of the stem.
 - Still very difficult to get anything right in the bow. Basically no reference points or measurements. Everything is extrapolated or done based off of pictures and estimates.
 - Constructing the stem first might be the best way to approach the bow.
- The issue with port bow section (including several different layers) not being in the main data set or properly aligned with it continues to cause problems. I find

while trying to reconstruct the stem that all the port side stem points are not in my point catalog, and the csv catalog that exists for them is unconverted to the proper orientation, and so the points are incorrect. Only solution I can see is reverse engineering the catalog by taking the points direct from Rhino into a CSV, but they still lack their proper labels. Suck.

- Two parallel lines aren't parallel. Hard to figure out, but basically need to decide which set of points is more accurate, and go more by those. For example, on SBWS, the lower outboard curve is significantly inboard of the upper outboard. Decided that the upper edge couldn't miss too far outboard, but the inside edge could have hit within the seam in a spot or two. Created points based on upper edge to get them to line up better. When upper edge is too far inboard, assuming it is heavily worn or chamfered there. So went by further outboard lower edge and will chamfer the edge once I have the shape correct
- In a general sense, not being there for the shoot really just means I don't know what to expect in terms of error. How far off should points be? Should I be nudging more or less or at all? Does a miss mean disregard, or just shift a little bit.
- Piece by piece notes
 - SB washstrake 4/16/13
 - Missing several points inboard and outboard, upper and lower edges. Used the opposite edge to recreate.
 - Moved the upper outboard edge outside at a few points to match lower edge. Figure it was worn or chamfered. Will adjust on solid.
 - Moved lower outboard edge out at one or two points to match upper edge. Guessing it hit the seam
 - Estimated the curvature making up the stern end of the upper edges based on pics
 - Added points to upper inboard edge to match lower as there is an XS point that was correcting a mis-shot that I cannot find anywhere in the points
 - Raising the forward upper points slightly to adjust for the wear evident in pictures. Will try to modify solid to reflect the wear SAVE 88
 - Played around with edges more to try to get closer to smooth curves like picture but still consistent with points.
 - Chamfered upper edges to get rounded feel to them
 - To get worn forward section, I estimated the limits of the missing area based on photos and known points, and then created a surface that went through this place. I then took my solid, and did a Boolean split with the surface cutting in order to divide the missing section, and then deleted it. Haven't yet figured out how to blend that edge nicely as it's rather curvy and uneven so the function doesn't work quite right.

- Used a cylinder to punch holes through at the correct angle of the hawse hole, and then use surface blend to connect the two holes with a cylinder running through them that's a little bit worn or looks to be
 - Also might work to use Boolean split with just the cylinder, but could be harder to smooth out edges
- BB Washstrake 4/17/13
 - Had to import several points from Port Bow extra points. Many are clearly mis-shots
 - Used stem width measurements and SB WS as a reference to create upper interior point, but it seems out of place. May need to adjust
 - Using the measurements to recreate the height of the stern interior point as well as several of the exterior ones
 - Moved the only outboard upper point up a little – seems based on pics to be taken where the edge is very degraded, so it will get trimmed with chamfering. Edit: still very off with other lines. Will recreate with measurements
 - Moved foremost upper outboard edge up to .066m above lower point to match closest measurements. Note that this makes it higher than SB WS, but this is confirmed in pics. Moved interior upper edge to roughly match but still a little lower matching pics
 - Moved inboard stern lower point aft to roughly match outboard. Either could be correct, but they should be roughly the same distance aft
 - blend edge is having issues. It wants to put the handles for the corner in the incorrect direction. Don't know how to change that. Can put those handles to zero, but that still makes a weird corner shape. Left one edge blended, but not the other for show. Can go back one save to undo. **TRY MODIFYING THE HANDLES IN OTHER VIEWS OUTSIDE OF PERSPECTIVE TO SEE IF I CAN GET THEM TO GO THE CORRECT WAY AND NOT SCREW UP THE EDGE.** It seems that the handles at the corner where the two edges meet are the problem as the handles face the wrong way. If I can modify the handles I can probably fix it. Save 99 with flawed blend. Going to try different things.
 - Solved problem – the corners were too sharp or had a slight bulge in them that prevented the handles from getting the correct angle of the blend. I am unaware of any way to change the angle of the handles manually. I went back and moved the points slightly down to prevent any kind of bulge near the corner of the two curves, and this solved the problem.
- Breasthook 4/18/13
 - Moved a few of the points up and down to make the lines even, and to accommodate for the blend on the edge that will take the edge down a bit

- Used widths on upper edges to determine points for back edges. WILL NEED TO BE SURE THESE CORRESPOND WELL WITH THE HULL. Ended up shortening them a little as the lower edge bulges a bit much with this method.
- Decided to move fwdmost lower point aft a bit. Pics show them it being roughly even with upper edge, certainly not fwd of it
- Drew a line through the points at the stern lower end of stem, then drew diagonals down from there through the top edge of the fwd part of the breasthook to get the angle of the stem and the lower edge of the breasthook. Put points there. No good shots of lower edge, so going to make bottom match top in shape with flat fwd edge.
- Built solid, blended edges, and then cut in half to represent the two parts.
- Floor 13 11/21/13
 - Started with basic lines around given points, then for missing quarter mirrored the existing fwd face points across line perpendicular from length of aft face. Moved new starboard points up to match the relative distance from the top of floor from points given on port side.
 - NOTE: Haven't smoothed or chamfered any edges at this point. Not sure if I want to for pieces such as this.
- Floor 12 11/21/13
 - SBFL12002 appears to be a missed shot, it is almost identical to 003 and not recorded in the point catalog
 - SBFL12007 (top of bolt) also seems to have missed, it's not on the floor at all. 006 is not in the point catalog. It could be the top of the bolt, though is also not ideally placed for that – ignoring for the present
 - FWD face points show themselves not on corners, but planking points relative to these show that they probably are when compared to photos. There are also no reasons based on photos to take these points anywhere else.
 - SB end looks very funny as shot. I believe that point MSFL12005 may have actually been taken too far up the plank rather than on the seam. Created a new point, and used the three existing points as the complete end, and this creates a more accurate shape when compared to the photos. Also moved the furthest SB point down into line with the other two in order to smooth out the top surface and better reflect photos. TRIED THIS, DOESN'T LOOK GOOD
 - Strategy 2 (really like 5...): Looks really like point SBFL12004 missed, and potentially hit hull. Extruded curve from points on BB side to make a straight line along top edge of floor, and then moved it down a necessary

to align roughly at or just below height of aft edge. This creates a more satisfactory shape.

- NOTE: haven't smoothed edges in any way. SB tip still has a funny underside, but that may be accurate as far as I know right now.
- MAY WANT TO REVISIT CHOICES MADE HERE
- Floor 11 11/30/13 and 12/5/13
 - When points are connected as recorded, the alignment of the aft edge looks extremely off. It looks warped. Pictures do not show this at all. It looks like the furthest stbd point is actually the fwd edge, not the aft edge, and that the 2nd point down from there is actually the lower edge of the bevel rather than the lower edge of the floor. The measured width supports my assessment as the width just from the aft to the edge of the aft bevel would be 2/3 or 3/4 the total measured width is constructed as noted. Connecting points with this assumed error.
 - Created fwd edge by mirroring points across a centerline created by finding the midpoint of the line connecting furthest STBD points (which I have concluded are the fwd and aft edges of the top of the floor), and creating a reflection plane down the top of the floor from there. This puts the total STBD floor width within a ¼cm or so of the measured width.
 - Moved STBD most point in to match length of other point. This again reflects the picture showing the end being uniform rather than having a pointed end. This overall floor still looks much more dynamic in shape than the picture suggests, especially with the angles on the bottom.
 - Had to create sides with series of patches to effect surface that didn't have strange curves in it. May need to smooth out. Picture does suggest shape changes somewhat (narrows) on port side, so decided not to normalize the width to correct the surface error.
- Floor 10 12/5/13
 - It seems the point labelled SBFL10002 is actually 003, and 002 was a miss. 003 does not appear on the sketch, but is in the correct spot, while 002 appears in the correct spot on the sketch, but is clearly off in reality, likely a miss, and a miscommunication between recorder and shooter. Correction, 002 is noted twice on the diagram, but the actual 002 is almost certainly a miss as it's far outside the realm of where it should be.
 - There are a whole series of points very clearly taken on the aft face that appear in the point catalog as MS rather than SB or BB for some reason, but are not noted on the diagram where they should be. Will reconstruct as best as possible. Correction, they are noted on a weird overhead fashion that makes MS make sense, but shows lack of consistency in recording strategy.

- MSFL10001 is unclear on location but seems to be lower edge of bevel, makes much more sense spatially as upper edge and will treat it this way. Need to rebuild various upper and lower edges on both sides. Will do so by mirroring other side and nudging to fit shape.
 - Choosing to ignore point MSFL10008; it shows as being recorded on upper edge of bevel, but putting it there drops that entire corner into an inappropriate shape based on pictures. Points taken on base of futtock also confirm that the corner should not drop like that. Using it as a point on the lower edge of the bevel also gives it a very non-uniform shape. It really seems either that point was the lower edge of the bevel and the BB end of the lower bevel missed, or it missed entirely. Not knowing where 008 falls, I decided not to use it for either edge.
 - NOTE: SHAPE FUNKY YET AGAIN – THIS FLOOR SHOWS A LOT OF THE PROBLEMS WITH DOING THIS WORK AND THIS PROJECT
- NOTE: The irregularities in floors can really start to be seen at this point. Being able to look down the floors without the hull there really gives you a perspective on this you can't get otherwise. They can appear fairly regular from above, but a view down them shows angles and skew that is extremely obvious.
- Floor 9 12/9/13
 - Going to ignore MSFL9005 for the moment. It appears the height is correct, but the point may have missed in depth and gone in the crevice whose location it's recording. It will be useful for that, but it breaks an otherwise properly straight line (by photo evidence) if left in.
 - Created SB lower edge of bevel by extending bevel line to a point that seemed to match upper edge.
 - Lowest SB edge end seems a little off, but it was projected given the break in the actual floor. Will use point as projected.
 - Created aft faces with mirror. Created a centerline by putting a line down the length of the top of the bevel end to end, putting a perpendicular line running aft at half the length of the measured top width, and then running a perpendicular line that became the middle line of the top of the floor. Used that as the mirror plane.
 - Afterwards continued in building simple straight-line floor from points. Continued to use no smoothing at this stage.
- Floor 8 12/11/2013
 - BBFL8004 seems to be a pretty bad miss, it's nowhere near where it should be. Must have hit futtocks or something, really can't use it as is.
 - BBFL8005, 006 also seem dramatically off, and will need to be left out or moved.

- Given that this floor is split by the centerboard trunk, this will be very hard to construct without the trunk in place. Will temporarily cease construction on this floor and floors in general until I can build the trunk in place.
 - Part of the issue is that video shows that the floor is notched for Mast step near the base of the Centerboard Trunk, but there's no points or notation or drawing of this whatsoever. Correction – pics show that the Mast step is on top of it, and it is not notched. Not sure if it's even broken, or if CBT sits atop it. Will need to study closer. Cannot ideally say if it is split or not, but Mast step butts up against it, does not sit on top. Notes say that floor 8 is not split, but runs under CBT
 - Floor 8 continued 3/12/14
 - Decided to only use BBFL8002 as a point in a control point curve giving it some value but not sticking to it, and ignoring 001 and 002 which warped the shape much more. The same choice was made to ignore 004 005 and 006. Wanted to include 005, but it gave an unnatural perfect curve shape that isn't consistent with the floor shape.
 - Also used SBFL8151 and 8150 as points on curve through points giving them some expression, but not sticking to them entirely. Effectively used both ends as good points for the whole floor, and used the interior points to give some expression to the arcing shape seen in several frames.
 - Used recorded frame width on each side to create a centerline to mirror the fwd side in order to create aft edges.
 - Centerboard Trunk 12/11-12/2013
 - First impression is that of the sole 2 points on aft edge of trunk, only TR001 hit. TR002 should just be the thickness of the wood away, but strays over to the BB side rather than being on the SB side. Will need to construct mostly from measurements. On closer examination, it seems 002 was simply marked wrong on the notes, as it looks to be the aft BB point. 001 on the other hand is not far enough aft, it is 5cm short of the measured length (002 is about 1cm off), and doesn't line up with Mast Partner points, while 002 does. Will extend the line back to align it with the 002 length.
 - There's some confusion on whether floor 5 runs under the CBT, or is broken for it. Some CBT diagrams have a cutout for it, others do not.
 - Lots of missed measurements on the diagrams for CBT.
 - Missed measure of height of FWD end of CBT. Used 504mm, measured height of aft end instead – this roughly aligns with the bottom of floor 5 as it should.

- FWD edge points are also diagonal athwartships instead of straight. Will need to figure out what is most correct there. Also may want to get basic frame of CBT done, then go back and finish floors that notch into CBT, then complete CBT. That gives me perspective, but the floors really are what should determine the notches, not vice versa. Will also probably extend CBT edge to hull bottom when complete as it should be flush.
- Going to build Floor 5 in order to allow myself to figure out where CBT edge should go. The different recorders differ on whether the floor is continuous, but I'm going with Nat Howe's interpretation as I trust his ability to ferret out the way things are put together, and his diagrams are very clear, as are muranos and danny bera's that agree. Only Saxon's diagram shows the floor ending at the middle block of the CBT
- Created FWD edge of CBT by dropping line from upper point through corner of Mast step where it meets corner of CBT below, then extending to roughly where the hull should be. May need to adjust the bottom area later. Realigned lengths to go with this line up.
- CBT CONTINUED 3/24/14
 - The front top of the CBT is clearly an uneven line. The fitted aft end of the mast partner is the same. Going to go with the points that mostly align, and create an edge there as opposed to the ones that are more FWD but only a few points there.
 - Created top of FWD section with measurements, and fwd edges by replicating BB edge on SB side. Tried to use MS points like SB side, but those points are unaccounted for in point catalog, and seem very confused. Shortened slightly to match floor 5. Then basically used floor 5 to create FWD lower edge of CBT.
 - Realigning the aft lower end of CBT to rest squarely on top of Floor 8, which measures the appropriate measured width, and therefore won't create a gap between CBT and floor.
 - Realigned vertical aft edge of CBT to sit go angular and sit on edge of floor 8 as on photos, but without changing measurements.
 - Splitting a surface of outboard CBT edge with floor 5 and 8 in order to get CBT to sit directly on top of it.
 - To create bottom edge of CBT, used floors. Extended bottom edges of floors 6 and 7 by arc, then trimmed them with a surface of an unshaped edge of CBT. Placed points on ends, and have a bottom edge that aligns with CBT. Can also use those lines later to rebuild floors to extend to CBT solidly. Used a Curve through points, but only included lower point on each floor to give it a smooth shape. Does create a bulge by floor 7, but there's a support Bessie rests on there, so that's likely accurate.

- Extended curves on floors 6 and 7 in order to pass through plane of CBT edge, then trimmed them to meet it. Built the notch in them noted by Nat Howe that notches partially into CBT by extended bottom edges 2cm (into middle of CBT plank), creating vertical lines up 2cm (arbitrary length), and then connecting these 2cm up on former edge flush with outboard surface of CBT. Will then use Boolean split to take corresponding chunks out of CBT solid.
 - Boolean split not as easy as it should be, so I'm creating "splitter" solids that are identical to the notch section of each floor, but extend further out the bottom of the CBT plank in order to create a clean notch and break. These work, but still some funkiness until I rebuilt the CBT plank manually rather than using extrude surface (got rid of some strange smooth shapes on the corners) and redid the splits. Worked great with the splitters, floors are now notched in.
 - Have no idea how many mortises there are connected top and bottom planks of CBT, or how deep they go. Going to make them just on the ends where visible, and 3cm deep. Created surface on the surface of the planks, and then protruded inward 3cm for solid. Actually moved out slightly and split then back in to split in order to ensure there was complete overlap with the edge of the CBT solid.
 - For SB CBT planking, copied construction framework from BB side, and then repeated above process of building solids and splits. Considered rotating it to fit the one point I have on the aft edge, but this would create error in many of the other measurements and angles that should align (like the MP that sits on the aft shelf). The error from the one point I have to the framework is roughly 5mm at most for the entire length of the CBT.
 - For SB side – making an arbitrary bottom just below floors that will then be trimmed by them. Used floors 5 and 8 to cut out their shape in surface of oversized CBT sides, then used that shape to create the bottom FWD and AFT edges. Floor 6 points could not be trimmed with the surface I'd created (points too low) so I extruded the curve downward to create a larger surface to use to trim them.
 - Aft bottom cutout of BB CBT plank was still not rendering correctly – remade solid with that cutout built with curves rather than as a Boolean split by using points placed on the edges of the old flawed solid. Doesn't fit perfectly around the floor (was actually a problem with the first one that was a later cutout rather than a surface cutout like the SB side) but decided that's likely accurate to not be exact everywhere.
- Centerboard Trunk CONTINUED 3/25/14

- There are no measurements for the end timbers between the CBT planks. Going to make the first one 8cm into the CBT – pictures show about double the width (4cm), and the bolt closest appears to not go through it, and is place at 9cm in measurements. Will extend them to the top of floors 5 and 8. EDIT making it 9cm after found photo with scale bar – it is about 9cm. points show it just inside of FWD edge of planks, photos seem to show it outside and then inside in different photos. Going with more recent that shows inside, but either is probably correct, likely intended to be flush.
 - MSTR004 is going to be moved slightly to align properly with the top of the planks. Will make it better aligned with 005. Moving 005 over slightly to ameliorate some wear evident on the corner, and to align with planks.
 - No measurements or good pictures of the depth of the aft end piece. Will make 9cm as well at the widest point, but it's obviously notched to fit the end shelf. One picture does seem to show it smaller at the top. Can't tell if it was originally meant to extend to the top of the CBT, so will go with measurements that show it being shorter.
 - Used a series of curves run along the existing plank curves that were then trimmed and adjusted with the measurements to create the framework of the AFT piece of the CBT in the appropriate space.
 - Going to proceed with building the relevant thwarts next in order to figure out the appropriate placement of the thwart supports on the side of the CBT
 - The depth of the notches for the thwarts is also unrecorded. Pictures show that they are roughly 2/3 the thickness of the thwarts, so I will use 18mm (thwart 4 is 27mm thick) as the depth of the notch.
 - Constructing the frame of the BB thwart support from measurements in space, and then connecting it with the alignment of thwart points projected on the CBT. Connected the framework to the thwart 4 point. The rotated to the thwart 5 point to get as close as possible to aligning the surfaces. Then built spurs up from the ends measuring 18cm (distance to top of CBT) and aligned the FWD end with the top of CBT, and then rotated the back end down to match on that side to align it at the appropriate angle down the length of it. Now will build out from that framework.
 - Realized this entire framework is facing the wrong way – the fwd side is pointing backwards. Need to rotate and realign or remake it. Might be easier to remake... Stopping for the evening. 3/25/14
- 3/31/14 CBT CONTINUED

- as the upper corner of FL, moved FWD slightly to make the chamfer more regular as in pics
- Reconstructing AFT shape was done by taking measured widths and creating aft points from fwd points. This give it a rather bent shape when incorporating the few points I have on the aft side.
 - Again, this all looks very wonky when the pictures do not.
 - Used Control point curve to normalize these lines as a test. Seems to give it a much more pleasing shape than the boxy curves of straight lines, or the winding control through points curve.
 - NOTE: WOULD IT BE WORTH JUST CREATING A NICE GEOMETRIC SHAPE AND INSERTING IT ROUGHLY WHERE IT BELONGS WITHIN THE POINT CLOUD? MAYBE ON SOME FLOORS THAT ARE POORLY RECORDED?
- INTERESTING IDEA TO REGULARIZE: Should I use control point curve that basically gives me a best-fit curve. This will normalize the pines to some point of wonky shapes without completely discounting them.
 - Drawings of spaces are difficult to interpret without a larger well-labelled pic to tie them all together. That would have been extremely useful
 - Floor 4 2/21/14
 - Reconstructing point MSFL4001 to be in line with rest of aft face, point taken is clearly on fwd face as aft face is missing, and point appears to be on fwd face
 - Disregarding MSFL4003, appears to be an earlier attempt to get the approximate point of the ridge in the correct area, but 006 looks like a later take of the same thing and appears better located in the results
 - Recreated lower edge of bevel on BB aft side with referenced location from SB points
 - Using control point curve to give smooth appearance as in photos. This creates an arc suggestion some sagging to the outboard of the vessel sitting in the cradle.
 - Recreated this floor as it should be, not with damage. Can do so with damage, but it would be entirely based on pics as there are no damage measures of any kind
 - NOTE: while using control point curve for this one leaves the points as shot some distance from my final floor shape, it does give me a nice shape that is much closer to pics, and is within about a cm of the hand measurements in all angles. On height it would be much taller with the shot points, but is about right now
 - EDIT 12/2/15 – the original shape of this has tremendous curve to it – inconsistent with photos. Are reshaping top of floor to minimize curve.

Although top points suggest some curve, the result from original design is extreme, and so I will modify slightly to better fit mast step and photos.

- Could be a good idea to recreate all floors using just measurements as a basis for comparison. Cool study. Could then look at which method seems to produce the beset or most accurate results
- Floor 2 2/21/14
 - Disregarding point SBFL2103 – clear miss, not anywhere near where it should be. Will need to reconstruct
 - After working with the points, it seems difficult given the shot and missing ones to establish quite how the floor should be. As usual, the picture shows a straight normal floor. Decided to construct from measures, then orient with points
 - Built basic shape from measurements, then used the points to show how far along the bottom shape is created along the different athwartship lines by using the TS points as reference points for reference lines on where to trim the box shape.
 - Given the shape, I oriented the aft edge on the points furthest aft, which seem a best place where points are hitting structure, and should be correct as to where that face is. Rotated slightly to align with the points on this face.
 - Not sure this is the best thing for everything, but seemed like the beset methodology here where missing points on one side and flattened points on the other hampered any strong effort at creating a single good edge.
 - NOTE: this methodology does not match the methodology creating curved floors used on other floors.
- Floor 6 3/5/14
 - Note, taking point BBFL6007 as the top inner corner rather than as marked. Makes more sense in context to be that point, rather than BBFU6014 which is the point actually recorded as being correct for that corner. The latter seems like it could be correct for the futtock, but not for the floor.
 - Created BB Aft side with a reflection over a centerline along top of floor created with measurements. Depending where they likely measured, error seems to be about 2mm or so at worst.
 - Rejecting points SBFU6004 and 005. Both appear to have missed badly when aligning other points. 006 looks better, and will incorporate into shape of the top of the floor.
 - NOTE some measurements on SB side do not line up with points. Since points have no obvious flaws, I will use them as the probable higher

accuracy in terms of shape, even if they may be slightly out off the measurements by hand

- Used same mirroring technique to create SB side. Only known aft point is very close to mirrored version, though used this one over mirrored.
- Used control point curve rather than curve through points as this doesn't curve the entire to of the floor, but only gives some reference to a single heightened point. Likely more accurate.
- See CBT notes above for additional modeling 3/24/14
- Floor 7 3/6/14
 - Discarding BBFL7100 – obvious miss that hit something else above the floor
 - Created a point for fwd top BB corner by duplicating BBFU7009, and then moving this point FWD until it aligns with the actual point as determined by BBFL7007 taken further inboard on the same edge. Moved down slightly to align with the top edge defined by the two other points.
 - Discarding points MSFL7013 and 014, which both appear to be misses inside the floor. 013 is possible, but is misaligned with the ends which seems to represent the shape better.
 - NOTE, inboard lower points of both sides seem very indented. But they are both like this. Makes me feel like I should leave them this way, but the shape then really disagrees with pics. Will move them for the moment to get rid of the warped shape, which then gives the floor a very nice shape.
 - Used mirror to shape aft sides again based on recorded width of floors on each side, which for 7 are 26mm different.
 - These do not look particularly aligned or similar in width. They match the given measurements, but this may want to or need to be re-examined with better use of photos.
 - See CBT notes above for additional modeling 3/24/14
- Thwart 4 3/25/14. Cont 4/15/14
 - NOTE: starting this in order to be able to place the supports on the CBT correctly since I was not given adequate information to do so. Will just place lines to note placement of thwarts on CBT in reference to longitudinal axis; I do have the apparent height above the hull.
 - Started on BB side. Created outboard FWD lower point by using measurements from TS point. Made curve from lower point to outboard Fwd corner of cut on CBT thwart support, then projected line to create a point on inboard edge of thwart support cut. This was to get the angle since a straight line would slightly miss the cut, and a line to the back

corner would intersect part of the support slightly. Used created point to form first edge, then built from there with curves and measurements.

- Created BB solid.
- Created grooves near edges by creating a line along the solid top 15mm in from the FWD and AFT edges and parallel to them. Created a pipe solid around this line with a radius of .0025m. Used a Boolean split to dig out a trough with the pipe solid, then deleted both to leave a notch along the top of the solid.
- Having issues creating a nice smooth rounded edge. Need to get better at edge editing commands in order to get this to work correctly for all the thwarts.
- Continued 5/21/14: SB side constructed in same way. Edges no longer difficult to construct for whatever reason, and fillet nicely with a radius of .005m. Note, needed to extend the pipes for the grooves further than the edge of the thwart for it to work correctly
- EDIT: 2/18/17 – notes and photos show that aft edge of SB thwart not beaded. Rebuilt with change.
- Thwart 5 5/21/14
 - SB side can be straight, it will fit into the slot for it. They do appear basically straight in photos, which 4 does not. Made a point directly inboard of the SB point on the lower inside edge of the cutout for thwart. Built line aft along the inside edge of the cutout .202m as measured, then copied this line and pasted to outboard edge of thwart to recreate the angle. Built up from here to form basic shape.
 - Note, for BB side had to increase the size of the shelf to accommodate the thwart, Otherwise thwart would taper, which didn't agree with pics. There were no solid measures for that particular shelf anyway, so I assume this is necessary.
 - Created first bottom corner by taking line to inside lower edge of shelf, then built the measured length aft along that edge.
 - Completed other aspects same as thwart 4
 - EDIT 2/18/17 – notes and photos show that SB thwart 5 has no beaded edges. Rebuilt with changes.
- Thwart 3 5/30/14
 - Don't like the point in the middle – good for measuring where the mast partner is, but it gives the thwart a curve I dislike, so won't use for the thwart.
 - Built out from the forward edge with points with measurements, then down from them. Added in grooves and fillets same as in 4 and 5.

- Tried to Boolean split with the CBT to get rid of the section that overlaps, but it didn't quite work with the multiple CBT pieces, so built temporary solid around the outer edges of the CBT and split with that instead.
 - Will need to modify for cutouts for futtocks when I get there, and adjust for curvature of hull.
 - Thwart 2 5/30/14
 - Built same way as in Thwart 3, but decided to do no finishing work. All will need to be redone to fit inside hull anyhow, so better to wait and come back to do grooves and fillets. Will just add basic shape with points for now
 - NEED TO DO: fit inside hull dimensions, cut out holes for futtocks, cut out center hole of MP, create/cut out pegs and holes for rigging based on MP position.
 - Thwart 1 5/30/14
 - Will need to use some points from futtocks. Have neither points nor measurements for some aspects of the rear edge. Front edge is generally documented well.
 - Thwart Update 6/3/14
 - Will need to come back to the rest. Need interior dimensions of the hull to really build the remainder given the details and how they relate to the interior of the hull in more extreme ways in the bow and stern. Organized points and then left off.
 - Futtocks 1 7/3/14
 - Some of my excel points aren't exactly lined up with my rhino points – they only are identical in 2 axis. See SBFU1100 and 1101. 1006 was a clear miss. Ended up shifting the points 1100 and 1101 over slightly to line up with others considering that dimension missed anyway. 1102 will be used as 1006 as it more closely approximates that position, and may in fact be mislabeled especially considering the degradation at that part of the wood.
 - Constructed the SB top entirely freehand based on pics and points that I do have. Aligned with given points, and built based on pics. Moved edges out a little bit to better align with the few measurements I have.
 - Ultimately created shape I'm happy with for SB, but may need to trim with hull when that's complete.
 - Con't 7/7/14: BBFU1009 was a clear miss, disregarding. The other aft point are fairly regular and create a decent shape.
 - Created smoothed corner shape by creating points near what would be a smooth corner on either side of the actual point, building the other curves to these, then extending one curve by arc to point of the other, and then

moving the points slightly until this smooth arc is very close to the original corner point. Ended up going outside the original point on Aft edge, inside on FWD edge to get closer regularity with picture and measurements.

- Used projected point BBFU1012 rather than point 1011 as the latter would put a kink in the curve, and the former as projected on the hull should be more accurate for a flush snug fit of the futtock.
 - Moved point BBFU1001 aft to align with other points. It clearly missed based on alignment and photos and measures. Also moved it outboard slightly for the same reasons.
 - For bottom points on FWD BB side, I created a lined showing the relationship between fore and aft corners at the top of the futtock with points on either end, then attached this to the bottom aft points I have to create FWD edge points. It's not perfect, but maintains the relationship in what is not a straight piece.
 - Came back to this one later and used Filet Edge with a .01 tolerance to create smoothed edges. Needed to manually trim some corners, but worked okay.
- Futtocks 3 7/7/14 and 7/8/14
 - There are very few measurements for BBFU3, and the ones that are here tend to be labeled very poorly. Could use notes on same pages the points were taken on.
 - BBFU3004 is a clear miss. Will not include in the futtocks.
 - Shifted 3008 and 3009 FWD slightly to align with other points in a relatively straight fashion in line with photos. There is a break and some splitting going on near this area that could be making the points make the futtock so wide at this point, and also so tall. Moved It FWD and outboard slightly. Still leaves a S shape to the futtock, but that might be in line with the hull, and could also be a reason for some of the breakage.
 - Recreated bottom end of top edge with a height above other one consistent with futtock thickness at other points.
 - Ultimately decided to move 3009 and 3008 further outboard to get rid of the S shape. There's no consistency in that shape with the preceeding futtock or the other edge of the futtock. Can come back to revise if it appear in the next futtock and should be developing. There is some indent on the outer hull as I have it now, but further fwd and not in a way that should affect this futtock.
 - Created curved tops with same strategy as on Futtock 1, as well as bottom same way with special curve from top points.

- Used fillet edge with .01 tolerance per handle to smooth edges out. Needed to manually trim some of the ends where the corners still stuck up. When this doesn't work, delete solid and reassemble with difference Join edge commands I think to get the edges closer to where they can fillet cleanly. PROBLEM: on some of these, when the solid is rebuilt, it ends up working, but appearing hollow where only interior surfaces are visible in any view. Don't know why. Don't know how to fix. Need to go back and play with this. Last save before error (without fillet work) is 145.
- SB futtock 3 has 3 points, which are all clearly out of line. Given the alignment of the points within the boat, it seems most likely that SBFU3003 was the miss, or biggest miss anyway. Will disregard and build as well as possible from measures and similar futtocks. Also straightened Futtock out a little bit since as shot it doesn't agree with pics at all.
- Used a rough line around other futtocks in the area to estimate angle since I only have two points, but it may need to be reevaluated later.
- WILL NEED TO REEVALUATE THIS FUTTOCK once I know more about the interior hull shape and the framing.
- Created Solid with basic built wire shape, then built a surface through it replicating the break. Made curve of break on front plane, then copied to back plane. Used these to create the surface, then extended in every direction. Boolean split failed, so I used a regular split, then the same lines to rebuild just the interior surface, and reconnected the edges to reform the solid.
- Finished with Fillet to the edges.
- Futtocks 5 7/9/14
 - Will reconstruct BBFU5 as fragments. This is clearly degradation, but the breakage is possible indicative of flaw in design or in usage that I may want to research later. Originally wanted to do whole, but I think broken is more important for later questions.
 - SBFU5002 and 5003 are almost certainly labeled backwards based on their placement. 5105 is a clear miss, but shouldn't hurt too much. 5100 is also a clear miss, and will be harder to do without, so will need to rely on photos and measures. BBFU5104 is a clear miss, but shouldn't be too hard to overcome. Calling SBFU5103 a miss as well. Measurements appear to be more accurate for this as that is clearly not taken on the same edge.
 - Borrowed a point from floor 5 for BB side. Need to remember to use dual points. Shifted a few points into a better line for SB side. They were pretty good, but showed an wavy shape at the top that is inaccurate.

- Used a control point curve instead of curve through points to create less curved top of SB side futtock. Built Aft edge with spurs of different length (depending on measured lengths) out from point on SB side, except did an exact replica of the topmost curve since that used control point curve rather than curve through points.
 - Got SBFU5 to a good point after much effort. Basically I created the solid, tried to filet edges, but it didn't trim correctly. So I went back to kept the new filet surfaces (2 areas of which required a blend surface command to complete), exploded the solid, manually trimmed what surfaces it let me. The ones it wouldn't let me I deleted, and then redrew lines along the correct remaining surface edges, and re-surfaced. These then all needed to have their naked edges joined because it would not auto-create solid. It was long and time consuming, but the end product looks really nice.
- Futtocks 5 Con't 7/10/14
 - Nudged some points into a closer line, but top chunk and bottom chunk may not fully align, and I think that's okay since it might be a part of or result of the breakage.
 - Deciding to ignore point BBFU5006. It creates a bump in my outboard FWD edge curve that really doesn't seem to exist in photos. Ignoring it makes a much nicer and probably more accurate curve. Had to move BBFU5101 a lot to get it to line up with other top half points. Thinking that at the break there's much more chance of error in the shooting.
 - Added a point on the inboard FWD edge to maintain appropriate thickness. This is still not as thick as measured, but that would give a huge bulge that doesn't exist, and I'd like to stick to points as much as possible. Measure could have been taken at an angle.
 - Built bottom point for top half by extending curve to theoretical corner as defined by the floor, then pulling a point down from the given top edge point. Then had to nudge new point in line with bottom edge points that run slightly angled assumed as part of break. Built top of first half same way as in previous futtocks.
 - Constructed aft edge with measured spurs from each point to create an aft shape, then nudged these points into straighter edge since there are few measures anyway and the rough average should be preserved by this.
 - Bottom half mostly built through measurements and off of the floor since there are only 2 real usable points on that chunk. Estimated the curves of missing pieces, and then built one side with measures and points, then copied to another 3cm away as in the width measure. This bottom piece

does NOT align with the top very well. I can't tell if this is very accurate in the picture or not, but it's true to the points on each chunk.

- Having issues with Filet of top chunk. It works fine, but then has strange surface running from top to bottom of chunk without any connections. Cannot select it to trim it or anything. Only visible from one direction.
- Futtocks 5 Con't 7/15/14
 - Finished Filet of top chunk of BB side. Redid surfacing and didn't have the strange connection with the filet, but did need to explode the polysurface, and delete then rebuild the back of the chunk because the top corners of the filed edges wouldn't trim properly otherwise. Final product worked out.
- Futtocks 6 7/15/14
 - Either SBFU6009 or 6100 is a miss since they should be similar spots but are not. Based on pics, it appears 6008 and 6009 are misses as they would have the futtock well above the floor. Will use floor point instead, and also drop 6006 down slightly so it rests on floor as in picture
 - Will nudge points to make a straight line along the widest point, because the narrower points on the top edge will end up narrower when I filet that edge anyway
 - Built the top FWD edge of SB side with 4 distinct curves. This futtock is heavily rebuilt, and has some smooth places, and some flat places with the reconstruction. Needed different curves to create this.
 - As has become usual, rebuilding back edge with the same points spaced by the measurements given for futtock width.
 - Filed edges with only a .005 tolerance. **THIS SEEMS MORE ACCURATE FOR THIS FUTTOCK, AND PROBABLY MORE GOING FORWARD.**
 - BB Side – disregarding 6005 as I'm taking 6006 and 6012 instead and all three don't work. Decided not to use 6013. It creates a flat that doesn't exist, it's well offline, and seems to mark some deterioration that I don't intend to put in. Moved 6014 up slightly so it doesn't eat into floor. Otherwise points need to be nudged into straighter line. Again, going with the bottom edge for the line as it's likely cleaner (this frame shows heavy deterioration) and the top edge will get fileted to make up the difference.
 - Left some curvature in the inside of the angle as this is specifically shown in the drawings and bears out in the points.
 - EDIT: Decided to keep all the points on the top edge in, just nudged into line. This gives a fairly wavy shape to the top edge, but pictures are inconclusive and the drawings seem to show at least some of this shape.

- Used my extend curve by arc to point trick to get top and bottom curves correct.
 - Built AFT edge in normal way with measurements. Fileted edges at .005, no difficulties.
- Futtocks 7 4/2/15
 - Only the FWD face is recorded, so there's certainly going to be a lot of missed points given the spread
 - SBFU7150 is a complete miss
 - BBFU7010 and 7011 are both misses as well. Might be useful in profile only.
- Futtocks 7 Con't 4/13/15
 - Recreated several points on BB FWD face to create an even plane, then reflected over half of measured width to create curves for aft face. Used floor to create bottom line and pictures to reconstruct breakage
 - The surfacing and filet was straightforward, but the trimming on the ends of the filet did not work properly, so I had to use brute force to explode polysurface, manually make edges and surfaces for outboard side of futtock, and then manually reconnect all edges to build the solid
 - Used Boolean split with created shapes to attempt reconstructing breakage at top of BB futtock
 - For split part, used the few points to make an outline, then built from scratch with pictures as help. The piece is heavily degraded, and I'd like to filet it heavily, but the shape is making it difficult. Was able to filet biggest edges, use those to split solid after extending end to extend out of solid, and then remake solid with the filets and remainder of original. Same procedure did not work for the smaller edges.
- 4/23/15 Futtocks 7 con't
 - SBFU7008 appears to be miss – it's off line and well above the floor. Will create newer point respecting the placement, but more in line with others. SBFU7005 also appears to be a miss, and must have been moved at some point as it doesn't exactly match numbers on point catalog.
 - After nudging some points into line, there is still a distinct curve that exists in the data. I do not know that it exists in the boat. I left it in some form to be true to the data, and in moving the upper edge to the aft side, I did adjust it FWD a little bit to account for the curving without the entire shape being warped.
 - Solid and filet of SB FU 7 easy with the correct filet order on each edge
- 4/24/15 Futtocks 8
 - Did some basic prep work on the futtocks
- 4/29/15 – Futtocks 8

- BBFU8003 moved FWD slightly to align with other points on edge
- Also moved BBFU8007 down to rest on floor, and ignored BBFU8011 which is way above floor
- Lowered BBFU8009 slightly to better match picture shape, but leaves bulge where it would be extreme
- Used curve through points to show futtock that changes thickness slightly throughout, then rebuilt top repair separately and inboard end similarly.
- Butt-scarf between original futtock and repair is recorded by missed point, so dropped a line onto constructed shape down from there to reconstruct
- Used Mirror command to construct backside that looks most consistent with photos
- Huge issues with filet on the top chunk. Tried rebuilding manually after creating filet surfaces and using those to create new curves that match their shape, but then new surfaces don't really line up like I want them to. I can't figure out a way to filet those or use filet surfaces to cleanly make those shapes. I need to better understand how to use filet... This futtock is not complete
- 5/1/15 – Futtocks 8
 - For top of BBFU8 I had to use the lines I created from the filet edges that wouldn't finish correctly, and then build entirely new surfaces with the original lines and those. I used surface between rails to build new surfaces on the filet created edges rather than the actual filets, and this seemed to allow me to build them and connect them better to build a good solid. Still boxy around the eds, but it's the best I've done so far.
 - Lower section of futtock fileted okay once I built the side pieces with surfaces from 3 edges in the correct order. The way the surface angles set up affected the filet success.
 - Found the futtock was too wide for the floor. Started over at the point of mirroring and narrowed it. Mirrored my created filet edges as well so as not to recreate them, and then rebuilt the surfaces and solids as above. Went much faster with established effective methods
 - Points on SB side were fairly straight. Moved two slightly FWD to get rid of a wavy line, and then added one point to keep the thickness consistent in the angle section.
 - Used copy and paste to create aft side, but made the toe narrower to fit on the floor while the upper edge still matches the measurement made by rotating the new side slightly.
 - Didn't add all the degradation. There's tons of wear that's not really factored in right now.
- 5/4/15 Futtock 9

- BBFU9009 is obvious miss. The rest appear close to accurate
- Shifted FL points slightly to better align with FU specific points. Nudged BBFU9004 slightly FWD to align with other points
- Moved some upper edge points FWD anticipating the file that will move that edge further in again
- Added a point on outboard lower edge to bulk out the area to match picture where 9009 missed
- Shifted 9008 up a little bit. Matches picture better, and point will adjust back with the file later
- Mirrored length across measured length, might need to change floor – the futtock extends off of it, but it appears the floor is too narrow by the measurements. No issues with surfaces or filets
- Moved SBFU9002 a little FWD to match other points and it will be more accurate with file. SB chunk east to build, but extra pieces will be more difficult.
- For small broken piece, I can extend the curves of the existing one and then use the other edge to build the chunk, and then move and rotate it appropriately.
- EDIT – rebuilt to match stringer, see stringer notes 2/13/17
- 5/6/15 Futtock 9
 - Built detached chunk of SBFU9 by extending the lines of the main piece by the measured length and then rotating to match pictures. It needed to be trimmed for fit against the main chunk, and will need to be trimmed for the repair as well. Did not degrade it heavily – there doesn't seem to be a reason to do this almost arbitrarily based on pictures alone.
 - For repair piece: built points along the lower edge of the floor and futtock as long as piece in pics, then straightened them to split the difference in aligning with the sides of floor and futtock. Nudged the points into a curve shape that matches pics as closely as possible, then used measurements to complete shape. Used chamfer edge that seems to match repair sections better
 - Broken piece needs to be unrotated and moved slightly, but also the corner chopped off a little bit. This matches sketches, but is not visible in the pics
- 5/11/15 Futtocks 10
 - BBFU10003 is clear miss. Will need to mostly do top piece with measures
 - They tried to shoot both edges of the chamfer, but most on the upper edge missed or are too scarce to be useful. Using lower chamfer edge points, and then moving them up to match the height of the upper edge ones.

When I reconstruct single edge then chamfer it I will achieve the same effect with the usable points.

- Top section of BBFU10 built mostly from pics and measures with the few points provided, then mirrored FWD for AFT
- Top section seemed to sit over thinned section of repair piece. Built thinned spur by using curve of existing and projected points and then extending line about 5 CM to match photos. Can't entirely see shape behind stringer, so reconstructed as well as possible.
- Mirrored FWD sides of BB futtock based on measures, then rotated new side on vertical axis slightly so it fits on floor and looks close to pictures.
- Final chamfered edge looks a little narrower than original points. I'm going to leave it for now, but it maybe should be widened to match better
- **Found that joining 2 naked edges with a patch works better if you select the patch edge first**
- SB side appears from drawing to be an old chunk at top and new repair piece divided by the thwart
- Toe of SB futtock recorded with FL point, but it looks like it's in the wrong place based on FU points and pics. Will move it down the Floor to match other indicators.
- SBFU10007 looks like it missed in its position along the boat. Will move to fit other points All points on SBFU10 are on upper edge of chamfer, so will move them out slightly so they will be more accurate when I chamfer
- Used thwart and stringer points to build the top of the lower portion (repair portion) of the futtock
- Futtock doesn't fit on floor, but probably need to redo floor since it's much narrower with points than the measure indicates
- 5/18/15 Futtocks 13
 - Multiple pieces of SB side each have one edge recorded, top piece has both edges
- 5/20/15
 - 3404 and 23405 were misses, moved to be in line with rest of points.
 - Added points to FWD edge of top piece to demonstrate curve and better match AFT edge that has curve from lower points. Tried to match curve of FWD as well as possible. Otherwise will use all top edge points as I have no specific reason to call them bad
 - These are all short on measurements, so I'm going mostly by pictures for recreating sides that are not recorded.
 - Filet on top piece not working properly, so will manually rebuild edges from failed filet to create solid.
- 7/7/15 futtocks 13 continued

- Had to manually construct most of the edges on the rebuilt piece. A lot of it is based just on pics and the shape of other pieces in relation to the hull.
- 7/15/15
 - Built the BB side of Futtock 13 same as others, and had to reconstruct surfaces when I tried to filet, as I've done before
 - Repair piece seems to be straight, so I left it that way while the original conforms to the hull shape.
- 11/12/15 – Thwart 1 Continued
 - Thwart 1 was built in line with the others. I used the points there, and then created points around the futtocks and used measurements to create the depth. The grooves and rounded aft edge were built the same as in thwart 4.
 - CHANGE 1/29/2017 – Bent the thwart slightly to go down in the middle. This matches both the mast partner, and the knees that rest on top of it. Cannot make it perfect with each shape, but points suggest that it does sag in the middle somewhat. Used Transform – Flow along curve to bend. Select the solid, and then have a reference line running along the axis of bending, and then creating a new bent curve to align the original control curve with. Creates a new solid, very useful command for future use.
- 12/1/15 – Thwart 6
 - Built primarily with measures and around futtocks. There were only 3 points to work with and used those as given. May need to trim edges around hull when constructed.
 - Built details same as 4 and later thwarts
 - Abandoned mast partner built by locating midpoint of constructed thwart, and making a hole through it of diameter 55mm to match mast step below.
- 12/1/15 – Thwart 7
 - Most aft points clearly missed. They go far behind the end of the mast partner, and the futtocks which is clearly incorrect with pictures. Will use hand measures along with other scantlings to construct. Splitting difference between FWD points that do not create a straight line
 - Raised points on SB side slightly to accommodate previously constructed futtock, and built cutouts for frames on both sides with help of futtocks, measures, and pictures.
 - Built the inlays based on measures, and then created solids to Boolean split to “dig out” the inlay, and then split again to shape slightly around futtocks. Has unique shape that is fairly accurate to photos, though some of the cutouts are slightly different around the frame, and there is clearly error in points on either the thwart location, frame location, or both.
- 12/2/15 – Mast Step

- Mast step points are highly irregular. Using other scantlings to build and place as well as possible.
- Aft end of FWD step BB side points seem correctly located, but others do not align with floor or CBT. Will use BB points to align. Created curve from BB points, then mirrored across plane of CBT to create SB equivalent. Created curves from this outline tightly around CBT.
- FWD points are also irregular. Using SB point on FWD end as what fits surrounding scantlings most accurately, and then building from there with measures.
- NOTE: description of obvious points (FWD SB point etc.) rather than specific point labels are far more practical to understand and recreate for some areas, so will be given preference when logical.
- Actual mast steps will be built with regular measured rectangles, and then places with points – the points are inaccurate but show general location. FWD step appears to be slightly offset to SB from points, and photos suggest that may be correct, so I will align the step appropriately. AFT step in FWD plank also seem offset, and will use combination of points, photos, and relation to floor to place a measured step. Actual slots made by Boolean splitting solids
- Also created notch near where floor 2 would be based on evidence in photos
- Created aft mast step with measures mostly, but aligning with two good points on Aft end, and between floors. Used same procedures as above otherwise
- 12/15/15 Mast Partner
 - The points are in the correct general shape, but should be flush with the centerboard trunk, and they show large gaps. I will nudge them into place around the CBT
 - Generally keeping other points as shot for lack of reason not to, but will create mast slots with shapes and a Boolean split.
- 4/7/16 – Mast Partner Cont
- 7/18/16 – Mast Partner Cont
 - After creating general shape with the points, I used measurements to fill in the gaps. Decided that the mast holes and interior shape would be cut out with Boolean split from points rather than constructed through curves and surfaces.
 - WILL NEED TO ADJUST THWARTS 1-3 TO FIT WITH THIS PIECE
 - Filleted edges with .005m tolerance as with other scantlings
 - Created inlay by edge with same method as on thwarts (Created grooves near edges by creating a line along the solid top 15mm in from the FWD

- and AFT edges and parallel to them. Created a pipe solid around this line with a radius of .0025m. Used a Boolean split to dig out a trough with the pipe solid, then deleted both to leave a notch along the top of the solid.)
- Aft Mast partner 7/25/16
 - THWART 6 NEEDS TO NOTCH INTO CBT
 - Adjusting points slightly to account for wear and tear off of corners, so that the main sections fit snugly against the CBT and the thwarts it rests on. Used measurements to determine how far to move. Wear will be partially re-established with the filet on finished product. This shows a lot of wear, but seems to include fileted edges and the beading near the edge (though heavily worn).
 - Placed holes in MP as well as possible with measurements and points
 - Used some method for beading and edge filet
 - 8/31/16 – Hull
 - At this point, all remaining pieces are closely tied to the hull, and it seems critical to have a handle on how to construct that before proceeding with anything else.
 - Initial testing of widdling method (creating solid block and then separating or trimming chunks) seems to have failed- solid loses various surfaces in the splitting
 - Lofting probably gives the best shape, but still is difficult to use and isn't smooth. Can try with more longitudinal or athwart lines, but still seems like the surfacing options aren't ideal for this complex a shape.
 - 9/19/16 – Hull
 - Best surface seems to come from lofting through a fuller version of the side of the hull, then cutting out the pieces that are oddly shaped. Gives a nice curvature and a clean break that seems to closely resemble the lines. Not perfect, but best yet. Deconstruct (explode) my lines on bow and stern showing breakage points to build fuller surface, then copy and paste the completed ones back in from earlier save file.
 - 1/25/17 – Futtock 10
 - Trimmed bottom of BB side to raise outboard edge off of floor as seen in photos. Originally had dropped edge to align with floor, but these have clearly separated. Used photos and drawings to estimate trim amount and created a splitting surface there, then Boolean split to remove bottom edge of futtock that had been resting on the floor inaccurately.
 - 1/27/17 – Thwart 1 Knees
 - Sets of points on both SB and BB are fairly straightforward to identify, line up well with annotated drawings.

- Outboard edges show very little curvature in photos, and only a single point on FWD face of each side to recreate angles. Will use points given to create curvature for all four outboard edges, and then comeback to modify as needed with hull construction. Inboard forward corners will also need to be reconstituted. No measured width at this point, so will use photos and measurements from Thwart 2 Knees. Used .04m which will narrow with fillets to be very close to .035 and .038 for the Thwart 2 Knees.
- SB FWD outboard point also missing – will continue line from two upper points downward until it meets horizontal level of SB AFT outboard point. Edit: nudging inboard slightly to accommodate estimated shape of hull.
- Thickness on inboard end is neither shot nor measured. Estimated measure from photos, and then blunted to match the same style.
- Used interpolate points curve to connect middle arcs, but did the end extreme curves separately with some added points to create more accurate individual curve sections better matching point cloud and data.
- Nudged BBKN1010 aft slightly to align with other points on that edge.
- Created surfaces using 2 Sweep on long sides, and then patch on fwd and aft faces. Manually created solid by stitched all naked edges together.
- Photos show heavy fileting on long onboard edges, so will filet with tolerance of .01.
- Added points on straighter ends of middle curves for SB side to help curves in areas with no data. Same as BB.
- Originally moved points SBKN1011 and SBKN1004 outward to make clean curves, but ended up using original points – their similar imperfections may show contouring invisible in photos.
- Built SB surfaces and solid the same as BB with rail sweeps, patches, and naked edge joining.
- Both sides extend slightly into thwart at different points. Either knees need to be higher, or thwart lower. Different points suggest each option is better. Ended up lowering thwart roughly .0035m as it was also in conflict with the mast partner. This resolves both problems.
- 2/1/17 Thwart 2 Knees
 - BBKN2020 and BBKN2021 are shown on the same point in the annotated drawings, and are very close. Using 2020 as the interior point assuming it must be closer to the junction with the thwart.
 - Created new points on outboard edges of BB Knee to reflect wear shown in pictures.
 - Built curves similar to Thwart 1 Knees. Once built, nudged all point wider and taller 4 times each to see how effectively fileted edges will then

align with the original point data. Eventually adjusted to 8 nudges outward and up, and this is just about right to make the fileted edge (.01 tolerance) match the original points as well as possible.

- Moving SBKN013 FWD slightly to better match photos and measurements.
 - Moving SBKN008 FWD to align with other points– it seems to have missed or hit inside a crack and is within the shape of the knee – does not reflect photos
 - Aligning inboard edge points slightly across both edges – the knee is very worn and the points are reflected shaping that does not appear to be present in most cases. Leaving some area where it seems to think near the top of the knee.
 - Added additional control point on lower part of SB Knee.
 - Used same surfacing and finishing strategy including the 8 nudges on the inboard edges to make the filet match the original data. This is by no means perfect, but much closer than otherwise. Might try 6 nudges for next knee since SB is perhaps slightly larger than original points, where BB was slightly smaller.
 - Created holes in each Knee by using creating a solid pipe on a line through the hole centers (located relative to points taken on outboard edges), then Boolean split. Estimated the hold radius at .005m.
 - Knees both extend into thwart 2, but photos show the thwart is basically carved out to allow this. So Boolean split the thwart and left the knees as is.
- 2/1/17 Thwart 3 Knees
 - SBKN3006 is a miss – well off the edge. All other points easily identified
 - Moved the forward inboard corner FWD slightly – the point made the end of the knee very narrow which does not match photos or measurements. Left narrower than other Knees (roughly .03m) to reflect the point as taken.
 - Added control points to smooth curves, and used the nudge method to account for filet, but otherwise points are good for SB.
 - Filet method with 6 nudges (or .003m) worked extremely well for original points. No problems creating solid.
 - 27 minutes for SB Knee, fasted scantling yet modeled? Virtually no problems encountered.
 - BB shows narrowing down towards the inboard edge, this looks like it is borne out by photos – will leave this in. Reconstructing BB missing lower corners with measures, photos, and data from other knees when necessary.

- Again, no obvious errors on BB points, will use the same technique with control points and nudging for filets to construct.
 - Fileting on BB side worked slightly better with 8 nudges than 6.
 - Photos show thwart is carved out for these knees as well, so using Boolean split as with thwart 2.
- 2/1/17 – Thwart 4 Knees
 - BBKN402 seems to have not been shot or is a bad miss. It appears in the annotated drawings but not in the point catalog or point cloud. BBKN4003 is also pretty far off the other points, and seems to have missed
 - SBKN4011 and SBKN4014 both missed. 4011 was noted as a miss in the annotated drawings and reshot as 4012.
 - Moving inboard aft upper corner aft to reflect photos and drawings better.
 - Adding control points as need to guide edges. Top of BB looks somewhat twisted or warped, but may be similar to photos. Hard to tell, so will leave that feature as recorded.
 - BB was best modeled with the nudging strategy at 6 nudges rather than 8.
 - SB shows lots of wear and a large break. Will model as if whole, meaning most points will need to be nudged to line up with measurements. Adjusted the aft edge which seems the less accurate of the two, and pushed several points aft.
 - Used 6 nudges to offset the filet. Still slightly large, but hard to judge with how fragmented the actual knee is.
 - Rotated each segment of Thwart 4 up at the outboard edge to come to the bottom or near the bottom of the knees. This throws the thwart points off slightly, but the inside edge is anchored on the CBT, and the knees have far more points suggesting they are located correctly – thwart only has a couple.
- NEED TO ADJUST SEVERAL THWARTS TO TAKE SECTIONS OUT OF THEM FOR FUTTOCKS
- 2/1/17 – Thwart 5 Knees
 - Data on SB is all over the place, and the points for opposite edges are almost on top of each other – the edges zigzag across each other as recorded. Will have to mostly be built with measures in the same area as the points, and using those only to show the curvature rather than actual edges. BB is significantly better, though will also require significant use of measurements. Otherwise built with same process as previous Knees with 6 nudges for filet offset
 - Top and bottom points are either mislabeled, are roughly where the opposite number should be. Using those switched.

- SB is broken, but given the lack of data I will be modeling it whole.
 - Angling up BB thwart slightly but knee seems to be sitting above it at present. SB will move knee down .002m since as needed since the points are so poor anyway
- 2/1/17 – Thwart 6 Knees
 - BB has okay points, but the FWD outboard edge appears to be too far FWD. The curvature looks good, but the decay on the frame means it will need to be nudged around similar to 5 SB
 - SB points are similar. FWD edge is very far fwd, and the top is recorded being far narrower than measurements, probably from wear. Used the same method as 5 to move the edges just enough to match the measured width while preserved the curvature. Surfaced and fileted as above with 6 budes for filet compensation.
 - BB aft points were used basically as is, just added a few control points to adjust the curvature. FWD points were moved FWD slightly to preserve curvature but correct width to match drawings. Filet compensation was 6 nudges, and otherwise created same as previous knees.
 - Thwart 6 shows signs of having been notched for these knees, so again the Boolean split was used to remove a very small section of the thwart solid that was the overlap.
- Hull again – 2/2/17 – 2/5/17
 - Worked with the wittling method again, but the solid is refusing to split – make just be too complex a shape to do at once.
 - Best method seems to be by building a single hull that includes all the different small chunks, patches, surfaces, etc. and then building them into a solid using the blend edge and join edge commands.
 - Exterior seems to fit best with surface from network of curves. Patching is always inaccurate, and lofting always does strange things on the ends where lots of curvature occurs. I still don't love the surface and will play more, but network of curves is best so far.
 - Interior surface
 - Decided to use my prior construction for me rather than against me. Tracing the outlines and points of all previously modeled solids that rest against the inner hull. These will be the majority of what I have to work with.
 - Using all the prior construction makes too many points to really get a smooth curve. Trying to just recreate one interior line for every frame, and use that to build a network of curves combining points/curves from futtocks, floors, and knees.

- Trick seems to be making a grid of curves that are only in two directions (a basic grid), which can then easily make a surface from network of curves. Need to adjust some things, but that method seems most effective at present, and gives a pretty solid interior surface.
- Effectively created my own network of curves by using whatever points from interior points or shapes were available, then using each other to build a grid of curves. Probably the least scientific approach of anything so far – more art and check my work than planning or points.
- Hard trying to get all the internal pieces to fit correctly, but it seems some of them are not correct. The Mast Step as modeled forces the bow into an awkward shape that makes the interior hull stick out past the exterior hull. Obviously incorrect. Will need to adjust the shape of the mast step. After re-examining the point cloud and steps used to make it, I think that the bow end of the mast step needs to be higher, so will rotate it very slightly upwards at the bow to better align with points. This will still leave a little bit of overlap with the preferred interior hull shape, but that will get trimmed off, and leave a hollow underneath that part that is flush with the hull. Impossible to say if that hollow exists or not given that we don't know the shape of the hull there, but seems very likely that it does given how the mast step runs along the floors above the hull for most of its length, and just connects as the hull starts to come up a little bit towards the bow.
 - Pictures also show that interior of the bow is closer to plumb than I have it. Will need to adjust my forward most lines to reflect this and move the base of the interior bow FWD to reflect this shaping and this will also better accommodate the mast step (which will still get rotated slightly).
- THIS REALLY GETS TO THE IDEA THAT THIS WAS CUSTOM MADE. NO STOCK PIECES, WHATEVER DESIGN WAS, THEY CLEARLY WOULD HAVE HAD TO GO THROUGH THE SAME BASIC PROCESS MEASURING, THEN CREATING, THEN TRIMMING TO GET EACH PIECE TO FIT. NO OTHER WAY TO APPROACH A SHAPE THIS COMPLEX. CANNOT CURVE THE PLANKS AROUND THE INTERNAL STRUCTURE. YET, THAT STRUCTURE IS ALSO BUILT AS IF IT IS THE PHILISOPHICAL MOLD FOR THE

VESSEL. INTERESTING IN TERMS OF RECONSTRUCTION THEORY

- ALSO INTERESTING THAT THIS IS BASICALLY DOING WHAT PHYSICAL/MODEL RECONSTRUCTION IS MEANT TO IN THAT IT'S TELLING ME WHAT I CANNOT DO. IT'S IN A DIFFERENT WAY SINCE IT'S MORE ABOUT LOGIC THAN RESTRICTIONS ON MATERIAL FUNCTIONALITY, BUT SAME RESULT IN SOME RESPECTS.
- HUGE PART OF THIS IS JUST FIGURING OUT HOW TO MAKE THE SHAPE
- Starboard surface for interior created as described above. Very successful shape. Will duplicate process for port side with lessons learned.
- Interior surfaces were by far the hardest thing I've made yet. There is some clipping with most of the scantlings, but the surface is to the point where I believe trimming is okay and necessary rather than continuing to try to refine. This is really driving home that the hull defines the shape of everything, and it's probably impossible to get it perfect, short of maybe a laser scanner.
- THOUGHTS AFTER INTERIOR – I FEEL NOW LIKE THIS IS A SHELL FIRST (OR BOTTOM) VESSEL BY NECESSITY, BUT BUILT PHILISOPHICALLY AS SKELETAL WITH THE AMOUNT OF STRUCTURE. IF I HAD TO START OVER, I WOULD START BY BUILDING THE HULL FIRST AND LETTING IT HELP DEFINE THE SHAPE OF EVERYTHING ELSE RATHER THAN VICE VERSA. HOWEVER, I HAD TO BUILD IT FIRST TO UNDERSTAND THAT, AND ALSO WOULD NOT HAVE BEEN ABLE TO CONSTRUCT IT HOW I DID WITHOUT LEARNING FROM BUILDING THE REST OF IT.
- Exterior Surface - With interior surface complete, will go back to exterior and design unbroken exterior surface that is accurate to points. Can then create solid, and break up for model as needed.
 - Rebuilt shape of original hull (before repairs) as best as possible from points to be able to make a complete surface to go over it before I cut it up with different commands to make the actual shape. This also might be necessary for float tests and characteristics

- Some of my original hull lines seems to have used curve through points. Went back and changed to interpolate curves which tends to give a nicer hull shape.
- Added a very few control points near bottom of some hull station curves to get rid of a a convex shape when there weren't enough points recorded on the bottom side of the hull. Photos show the hull tends to be flat or near flat on the bottom, but I don't think it gets quite to convex.
- When looking at the stern, BBHL062 seems to be a miss and hit the ground. Will not be using it. Otherwise building unified hull shape same as forward – using hull, transom, filler, and any other points to try to make the most complete shape that can be trimmed into the log later. A whole bunch of transom shots missed as well. Those recording the lower SB edge of the repair planking shot are all on the ground or other objects well past the hull. Looks like they were not backstopped properly during recording – the shooting angle is visible by lining up the points with where they are supposed to be in perspective view.
- Not using the points shot on lower BB side of transom for total shape as they record the location of planks (not important for this) but give the shape a wonky feel with slight variations. Also the bottom most point missed, but the inside edge of that same plank hit so I can recreate it based on that one.
- Save 248 has pretty much all the curves and point movement for full outside hull shape before I start surcaing and adding curves solely for that purpose. Creating a LOT of sublayers here to try to make surfacing easy without getting rid of any modified lines or useful data I've created and might want for trimming later.
- Surfacing with same technique as inside. Running longitudinal lines down length of section lines to form a better grid for surface from network of curves. Generally a smooth process, but not using a few hull points that create odd shaping where they shouldn't. Example, HL300 and 301 are the only points recorded in that area, but create a bulge when used. Not using them actually makes the surface much closer to that area and far more accurate to photos and drawings. Also rejecting a few points near the bow that create odd surface shapes for the complete hull, but will be useful for cutting the log or building repair pieces later.
 - ALTHOUGH I'M IGNORING DATA HERE, IT REALLY SEEMS MUCH MORE ACCURATE TO NOT

USE DATA POINTS THAT CREATE CLEARLY
WRONG OVERALL SHAPES. IGNORING THE TREES
FOR THE FOREST EFFECTIVELY.

- Starboard stern quarter shows some weird shaping, there are no sections in that area. Will use surface to add some points to that area, and then adjust them to try to smooth out and better match the port side. This seems to work pretty well. Used my created longitudinal lines to create sections, then skipped a few of the weird longitudinal ones to create a smoother section curve then redid longitudinals to match new sections.
- For transom, patch gives the nicest shape. Will need to ensure that edges are joined from other surfaces to ensure accuracy as much as possible.
- Save 252 has complete stitched together hull for the first time.
- As anticipated, the complete hull solid is too complex to simply Boolean split with the splitting surfaces I've created that follow the log contours and ends (basically the log minus the repair areas).
 - Trying to explode the solid I made, and then split the surfaces instead. These can be stitched back together with a few more surfaces added in to make up for those that are gone. This works with all surfaces except the exterior starboard surface, which will not split... Next step, rebuild the curve that the splitting surface is made from. Will also need to continue carving out the bow, which has more than the basic surface missing – also a hold all the way through.
 - 2/6/17 – the surface seam was running along the surface. When I moved the same surface sideways a bit so the seam does not line up, it worked easily. Lesson: joining two surfaces does not create a single surface – there is still a seam. Might have been different if I had joined naked edges I guess. 254
 - For bow degradation, realized that the repair block in the middle of the bow goes all the way back to the mooring bolt, which means the log does not connect STBD to PT at the top end. Only the bottom does so. This means I need to tear out more of the interior of the bow with some cutting surfaces, and resurface them as needed to encapsulate this shape and allow for the insertion of a repair block to fill the void.

- FWD end of port interior surface is basically correct – there doesn't appear to be much repair block on that side, so remove the front surface then that should be in the correct place, will just need to leave the lower part of the front surface. STBD side, will need to cut off some of the front of the interior surface. Using point on Mast partner to see where this is since it's very close to where the hole is.
- Created angled surfaces for seating FWD planks by measuring .02m in and fwd from the corner of the exterior lines, and then building a surface from those points.
- COMPLEXITY IN THE BOW SHOWS HOW THIS HAD TO BE ASSEMBLED. THIS IS ONE LOG, BUT IT'S NOT THAT SIMPLE. THIS DOES NOT SEEM TO BE ALL REPAIRS, AND PRESUMABLY THE WOOD WAS NOT SOUND ENOUGH FOR THIS OR COULDN'T QUITE MAKE THE SHAPE THEY WANTED. EITHER WAY, THIS IS COBBLED TOGETHER IN MANY RESPECTS – MAKES IT VERY HARD TO MODEL
- Interior of bow – impossible to say exactly what the log is shaped like. Used a likely shape based on exterior points I do have and what I do know about the interior, but did not worry too much about smoothness in there. Same goes for area of the stern under the decking. Used what I knew of outside to interpolate.
- First attempt at joining surfaces of log together was okay, but not great. There are some seams that do not want to join, and many of the curves are broken into their constituent parts. Will have to try again and be very careful in which edges I'm selecting when and in what order.
Unjoined surfaces in 262
- May need to redo my triangular surfaces – edge joining does not seem to like those. Redoing worked slightly better. Still 1-3 edges at the stern starboard that cutout that won't be joined. There is no error reported, they just continually redo again and again. Does not seem to cause any genuine harm to the solid though.
- Stem – 2/7/17
 - There seems to be a problem with the point catalog – cannot find many of the points based on the locations on the stem. Seems there may be a section of data missing

from the first or possibly first two deployment sections. There are also clearly several misses here. Measured drawings are generally good, but some measurements in standard while most are metric – not consistent

- There's a ton of wear on it, but other than the edges going to try to build it pretty much in one piece. That seems to be the best option given the issues with the point cloud identification
 - Figured out most of the points based on location relative to better labeled hull points.
 - SEEMS QUITE CLEAR I NEED TO REMAKE THE FWD SECTION OF WASHSTRAKE
 - Budging some of the lower points on lower stem rabbet to fit with surface better. All of these points seem to make the lower stem twisted slightly, but photos are not clear on the matter, and the points do seem to line up.
 - Moving the points marking the very SB bottom edge of lower stem. They do not align with others, and would make the bow crooked (more than it is) as recorded. Rabbet outside marker (SB) is also out of place though. As recorded, it is outboard of the plank that ends up on top of it.
 - Lower stem looks really funny, and asymmetrical, but the more adjustments I make, the more it lines up with points that I thought were initially the wrong ones (since the catalog is missing for the stem). Means the rabbets are different shapes on each side, and the SB side sticks out a little more. Cannot confirm or deny this through photos.
 - Created the unique shaping on the bottom of the SB lower stem with a Boolean split after making the main solid.
 - Creating bottom triangle was very easy. Adjusted the top point slightly to match the lower stem, then just built surface from points and extruded along back of lower stem to match.
 - Fileted edges of upper stem to .005 tolerance. Can apparently filet all edges at once! Would have made life easier...
 - Have to estimate the diameter of the holes in the stem – they were not measured.
- Extra planks on outside of hull 2/8/17

- Quite a few points for these, and they are easily distinguished from others based on location – most have already been used for hull/stem construction. However, BB hull points may be missing from point catalog. Rejecting aft most point of upper repair plank – shows in wrong place compared to hull, and no point catalog to check the point identity.
 - Based on photos, there seems to be an otherwise unrecorded filler piece of wood inbetween the port log of the hull, and the large SB repair/filler chunk on the bow section just aft of the upper stem, and fwd of the MP and breasthook. The model with recorded chunks leaves a gap there, but there is definitely a piece of wood. Will use the dimensions of surrounding shapes to reconstruct – fairly simple since it’s constrained by several other pieces.
 - THIS REALLY AGAIN SHOWS HOW THIS SECTION WAS COBBLED TOGETHER A BIT. THERE’S A SPACE OR GAP HERE THAT IS OBVIOUSLY FILLED, EVEN THOUGH IT’S ALMOST IMPOSSIBLE TO SEE WHAT PART OR PIECE IS FILLING IT. BENEFITS OF RECONSTRUCTION, AND THE USE OF 3-D SPACE TO SEE THAT SHAPE THIS REALLY HAS TO TAKE.
 - Even after I inserted this piece, I then found it needs to extend further up, or there’s a gap behind the breasthook as originally recorded. Save 271 this is complete
 - Strange little filler piece on SB bow section I went mostly with points, but used them as the internal instead of external. Their locations simply didn’t work very well for external points when compared with the stem and other filler points
 - Created the repair piece inside the bow shape first (simple shape with straight edges defined by other shapes), and then used it to curve exterior planks around to define the shape better.
 - Built SB planks by creating little spurs of the thickness off the interior repair piece made inside. These then helped create curves with given shapes to make outlines and solids. Used Boolean split with log and stem to trim slightly and make the angled surface where it fits onto the log. Sometimes this worked easily, others had to be trimmed and manually stitched back together.
 - Starting to texture these using screen grabs of the actual parts. The resolution is terrible, but it does convey the correct colors in general, and looks pretty cool.
- Extra planks on bow and upper repair pieces – 2/9/17

- Built these same as described above using the recorded points and adding lines as necessary. Very little was measured when this was recorded, but there were many points shot that allow for others to be reconstructed relative to those taken. Photos were absolutely essential.
- In some cases moved points slightly to match photos, or coincide with my log/hull. I did trim a few areas of the hull and stem that did not fit with the recorded planks, but mostly I trimmed those to fit the outline of the log since I'm fairly satisfied with the shape I have.
- Repair section near SB gunwale aft quarter. 2/9/17
 - The first four points are recorded as being the FWD section of this, but they're a frame too far back. Photos show it starts a frame earlier, and this is another repair section right by it. The points also bear out that this is not labeled correctly in the diagrams.
 - FWD points are actually recorded as Planks rather than filler. Used these but did not relabel for continuity with original recording.
 - Simply Boolean split main log hull with cutting surfaces derived from the points, and left the resulting solids as the pieces. Very simple.
- Remaining Filler areas 2/9/17-2/10/17
 - Basically used the point given to create surface planes running through the hull, which are then used to Boolean split the hull leaving exactly fitting filling pieces in place
 - Found that the hull is a little wide at the stern SB side. Some of the points are slightly inside the log. Would be good to address this shape if possible.
 - With some of the stern repair chunks, there is some mystery in terms of how they go through the hull. In particular, the chunks labeled E and D on the stern diagram show differently on the front side. The small pieces below C don't show at all on the front. Best that I can figure, several chunks of wood were used to fill gaps here, and it may be impossible to say what they look like inside without disassembly. Ended up going with a series of small blocks that incorporates the data with photos, points, and measures as well as possible. Not unlikely that some strange shaped blocks were cut and stuffed in strange shaped rot holes as needed.
 - **SOMETHING LIKE THIS MIGHT BE A GOOD THING TO WRITE ABOUT – HOW TO APPROACH, ISSUES WITH**

RECORDING BUT ALSO HOW THIS CAN HELP FIGURE IT OUT IN 3-D IN WAYS THAT 2-D WOULD BASICALLY BE IMPOSSIBLE.

- These rear chunks are extremely difficult. Every time I split, the log gets more and more complex and is that much harder to successfully split the next time as surfaces make funny shapes and are not easily reconstructed. Sometimes nudging a point slightly so that the splitting surface is not directly aligned with another is the way to go. Now I'm thinking maybe for the connected ones, do one large split and then slit that piece again repeatedly to make the smaller chunks.
 - Save 292 is going with splitting the hull several times. 293 is with one big split, then splitting that piece up repeatedly. Can't really tell which is more effective right now. Both cause different problems. 294 is second attempt at single split then subdivided
 - 295 is a continuation of 294 with surfaces made but not joined together. This is not working either. The split is simply too complicated. Next will try to go from the top, so I'm never putting a hole straight through the hull, but one or two chunks at a time carving out a section connected to the edge/repair hole already. This also failed. 293-296 did not work.
 - Picking up 292 and saving as 297. Save 300 finally is it. I split off all the topmost chunks that extended up and out of the hull shape, and then used a series of flat surfaces to subdivide and Boolean union them into the correct repair chunk pieces. It was very complicated. The construction sublayer is a mess, but I honestly don't know how to have better approached it. There was a lot of splitting and lots of curves, surfaces, and extending things to stretch out of the solid. I have to think there's a better way, but I'm not sure what it is. The complexity of the hull just makes everything so difficult since I cannot just build that with curves and surfaces that I stitch together. It must be a complex shape that is then split down. I don't think there's another way.
- Planks in stern area 2/10/17
 - This was a really easy model. There were points on every corner but one, and easy to create a smooth curve. Duplicated the set of recorded curves on top of planks, moved the duplicate set down .019m as measured for the thickness, then built solids out of them using 2 rail sweeps. Created solids, then split with interior hull surface to trim the bottom edges.

- Virtually no issues with this process other than having to switch from a patch to a 3-curve surface on the BB one as the patch solid wouldn't split right. Otherwise no complications whatsoever.
- Repair section on upper edge of port hull – 2/11/17
 - This is seen in photos and drawn, but does not seem to be recorded by points except a single point on the futtock of Frame 10, but the point labeled as such is much too low on the hull to be the same repair. It is measured, and so will go by that.
- Vertical planks in stern 2/11/17
 - Several of the bottom seams have points, the rest can be interpreted with photos and from the top points which were measured running across the beam and easily reconstructed.
 - Otherwise built planks same as planks they connect with by building the visible surface, then duplicating it and moving it back the thickness of the planks (assumed to be .019m, same as horizontal planks here. Built them deliberately long, and will use the hull to trim them to the appropriate shape.
- Patches and planks in stern bottom of boat 2/11/17 – 2/12/2017
 - These are really very complex. Although they are fairly straight down the hull, they conform to the shape of the boat pretty smoothly in most cases, though are sometime flat on the top. Some curve better than others, but they are fairly well shaped on the outside of the boat except where broken.
 - One difficulty is determining if it's a single repair piece extending through the hull. I would think yes for most of it, but on the port stern quarter there are some very damaged planks on the outside, but the ones on the inside do not share the same clear damage and don't look torn away from the hull (or pushed through in this case) as the others do. Makes me think maybe there are interior and exterior planks at this point? The spots basically line up though the exterior ones were not recorded well in any fashion. Looks like exterior hull was recorded as if the damage did not exist.
 - Further examination of the photos determines that the exterior break is lined up pretty closely with the broken up area of the patch on the inside surface. Still not convinced that this is one piece though, but the damage seems to be roughly in the same spot. Video seems to confirm this. I believe it is one set of planks, and they are broken out at that point and some are sticking down outside the hull to some degree.
 - Built the shapes of the planks in 2-D on the surface of the interior hull. This required lots of measurements, use of other points, and reference to

photos. This is not going to be very accurate due to lack of points in this region. It is also probably why the hull has a funny interior shape in this area currently. 307 is this point before any surfacing or splitting. 308 is with a full split through the entire hull.

- 309 is going back to no split on there yet, but keeps the surface to use later if need be. It is unclear to me if that repair goes through the hull or not, but currently I guess that it does not, and those planks are merely repairs for the decking while the other ones actually penetrate the hull.
- 311 is main splitting surface for the various planks built, but nothing split yet. 312 is with the split. 313 is with a solid. Build it by tracing the edges of the hull on the curvy side and the bottom, and using a straight edge in the middle where it's more of a plank. I think this is the right general idea, but the plank needs to be flatter on top, and not trace the interior of the hull edge so much – the resulting surface of that is too curvy and it should be flatter. The outside one is probably okay since this appears to blend in with the hull pretty well.
- Final method: using the points of the curves, and the heights of the floors (which don't match the hull very well here because they are planks and not real even, creating planks that extend through the bottom of the boat, then trimming with the exterior surface. This creates a mostly flat interior (but does have some funny shaping thanks to the floors. They still have the look of mostly flat planks though and would have some shape put into them, rather than the curvy look of the original hull here. The floors fit MUCH better.
- For the planks on the port side (3 skinny and one larger), they have a break that is both visible on the inside, and makes them bulge outside the hull. I will basically construct them whole from frames 10-13, and then I will use the break line to split them, and rotate the broken part out of the hull slightly to the level of floors 11 and 12 which as down lower, it looks like due to the break.
- 320 is a save point with all interior planks on the main section built, but not yet split to simulate damage. 322 is with damage made. I basically had my planks as they fit with the hull shape, but not with the floors which are angled down somewhat to reflect the damage. Using the split line, I created a splitting surface, sheered the planks in two, and then rotated the damage sections down until they rest just below the floors from a side view. This makes them stick out the bottom of the hull, which is accurate to how they look in photos.
- THIS SECTION REALLY WASN'T UNDERSTOOD PROPERLY UNTIL MODELED. I STILL MAY BE WRONG ABOUT THIS TO A

DEGREE, AND THE MODEL IS FAR FROM PERFECT, BUT I BELIEVE IT TO BE A GOOD REFLECTION OF WHAT OCCURRED AND HOW IT HAS AFFECTED THIS AREA OF THE VESSEL. THIS EXPLAINS THE PLANKS COMING OUT THE BOTTOM, BUT REALLY IT EXPLAINS THE FLOORS. THESE FLOORS HAVE ALWAYS CLEARLY HAD A STRANGE SLANT TO THEM, AND THEY ARE ANGLED BECAUSE THEY ARE PART OF THE PROBLEM AND ARE PUSHING THE REPAIR PLANKS OUT THE BOTTOM. AGAIN, MODEL IS NOT PERFECT, BUT MODELING IT HELPED IDENTIFY WHAT WAS GOING ON HERE.

- Am angling the stern “unbroken” sections down very slightly to be more accurate to photos and points, and probably they would also have been affected by the breaking. Very slight though in this case. 323 is complete with that change.
- Planks in stern SB quarter of hull 2/12/17
 - This is somewhat problematic – the top repair section is easily modeled, but it’s hard to say if these went all the way through the hull or not. Photos are inconclusive, but suggest that they do not, and this repair was to keep the interior shape and decking intact. Due to this unknown, I will basically use these to fill in a follow spot that I will create in that area rather than creating a complete through hull. I will carve out a depth of .05m, and then fill with planks of .19m to mimic the planks used to create the stern decking (even though these planks look more carved than the stern deck ones, the deck gives me a sense of what thickness they found appropriate for such things.
 - 326 is building the sections by themselves. These however stick out a bit from the hull interior shape. 327 will be trimming them with the interior shape to fit better flush with the hull, which is what is shown in the photos. 327 is definitely a nicer shape, but is a source of error since the points have it higher. Very tough since the hull is clearly a little low here, but the planks sticking out is extremely inaccurate.
- Keel – 2/12/17 – 2/13/17
 - Does not appear that SB Keel points are in the point catalog, though I will keep looking.
 - KL002 looks like it missed in the dirt. Point only identifiable with those near it since they are not recording properly in the point catalog. KL004 looks to be the same since it’s not ID-able, and does not appear where it should.
 - It’s possible some of these points have been nudged. Seem to match in two dimensions, but then off in the third. Possible it was changed before I

received the data. When I'm quite certain it's the right point and I need it, will use anyway since most are hull points nudged fore or aft to correct frame straightness and shouldn't affect this that much.

- Overall there's a decent point cloud for this, it's just lacking clear points in some places, especially on the ends where many points were not backstopped or missed. Good drawings are present though and will be useful.
 - MSKL502 looks like it's too far off the hull to be accurate. The points I'm using give very close lengths to the measurements taken on the keel.
 - The points taken on the top of the keel are mostly hull points, and thus probably prone to miss a little bit due to the extreme angle. Using the measurements and then orienting them with the points taken seems to work very well. Built basic curves running through known points, then put curves athwart these at the points measurements were taken. Used the middle point of these athwart curves to build the measured sections. In this way I established a centerline from the measured point. On the upper edge. This is almost universally smaller than the recorded points except at the extreme bow. This again supports the thought that the lowest hull points taken as the top of the keel also likely hit just slightly inside the hull rather than quite at the top of the keel. For bottom edges, given points are slightly inside measurements, suggesting wear or damage (which appears evident) is to blame for the difference where they were taken.
 - Built mostly from measurements in this case, but used given points where they align well with measurements. This gives an overall better shape more representative of the piece as a whole. Did not model the damage, which was not well recorded and not entirely necessary anyway.
 - Once solid was built, filed the outboard corners at .01 tolerance to match photos, and better align with TS points.
 - Created a cutting surface centered around CBT, but with witch measured on keel to create through-hole for the centerboard.
 - Built the separate forward section with the measurements and aligned with the intact section. Mostly sculpted the bow from measures and photos for reference. Split out section of stem and hull that pegs insert into based on where it lines up. I did rotate the section of keel very slightly to align with that better.
- Stringer 2/13/17
 - The points are really nice excepting a few in the middle that seem to have hit obstacles. These are pretty clear when curves are made, and the curves are really nice when these are left out. Didn't use SBST003, SBST004, SBST357, SBST355, SBST352.

- Issue is when the futtocks are involved. A lot of the nice looking curves pass through futtocks, which obviously they need to rest on top of. Will start adjusted points to be sure they rest on top. Note that a few futtocks look like they would be better adjusted instead because there are no points in that region, so will do that as needed.
 - Moving futtock 9 outboard, and will trim with hull. I used measurements on it, but points and photos show it not being so large, and
 - Had to redo several points by putting 2cm spurs off of futtocks to bump the stringer out enough, and give it the correct spacing. This will alter some original points, but others I kept where possible. Also will be similar not entirely off since it will be fileted when done.
 - Once I had the shape, which took a lot of finagling, I used the same method for beading as on the thwarts with a pipe running in from the edge following the same curve, and then using a Boolean difference to hollow out that area. Pipe had to be dradius of .0026 instead of .0025 as it wouldn't quite work with the lower tolerance. Fileted edges at .005. EDIT – if I project the line onto the solid I can do .0025 and it is much cleaner. Went back and fixed this.
 - Shape of SB is not quite as smooth as I'd like to be a bent plank of actual wood, but it's not far off. Getting it to be a clean shape is so hard with all the variables here, this is about as good as is reasonable to expect I think without better points.
 - Need to adjust thwarts to fit in hull before I split the stringer for it. Going through and adjusted thwarts to be sure they're in contact with hull and stringer. For EX, thwart 1 measurements are clearly off – too high and not long enough. Photos and points show that the thickness measurement was off.
 - All thwarts adjusted for hull size, and then split with hull, mast partner, knees, and then finally stringers split with thwarts.
- Gunwale – 2/14/17
 - On first inspection the point cloud looks very good. Seems to be one of the cleanest I've seen on any piece before I look took closely anyway.
 - Upper inboard stern-most point on SB side seems to have missed a little long where the taffrail is damaged, so trimming that down a bit. BB side 3 of four edges seems a little short by the same measure, so extended those. Can trim later easily if needed.
 - On closer look, entire rear end of SB rail seems to be too far inside and up off the hull for some reason. Will move the points within the same shape into an area that matches photos and measures (angle outside down onto

- hull edge, and move outward). This almost seems like an alignment issue since they seem to be in the correct spot on the inboard side. Impossible to say if the transom measures are off instead. Will actually leave the interior points, and have it widen out back there since that is possible.
- Once solid is built, will chamfer edge by .01m and then filet those edges by .003 to smooth it out along with the interior edge. This creates a really nice shape. Also moved the points on the upper outboard edge outboard slightly to result in the chamfer putting them into the proper place. EDIT – the filet really messes up some of the chamfer. Will have to skip it to preserve a nice clean shape.
 - Trimmed the repair pieces on BB and SB bow slightly to get rid of overlap with gunwale. There's also some very minor overlap with the main hull, but it is too minor for a split or difference to be successful.
- Rubrails – 2/14/17
 - I now believe quite firmly that the points on the very stern SB side of transom are incorrect. The rubrail ends up inside the points, and would agree very well with the original aft points for the gunwale. I can see how the wineglass stern would also be cleaner if this ended differently. Cannot possible change this without completely redoing the hull shape. No an option currently unless I can go back and redo that at a later time.
 - SB side had good points on lower edge, and upper edge matches bottom of the gunwale. Built this surface, then extended the points inboard well past the hull to create an extra large solid, then split with the hull exterior to help it line up and smoothly fit against the log. Fileted surfaces .003 tolerance to smooth out.
 - Lower edge of BB rub rail recorded with hull points, but these are on the inside lower edge rather than the outside. Built a curve with them and then extended them outboard .025m (as measured) to build the correct outside edge. Otherwise used the same strategy for BB edge as for SB.
 - The FWD edge of BB rail didn't cut well, and was actually longer than the photos, so after fileting the edges I just trimmed it slightly so the end looks nicer and matched better.
 - Washstrake – 2/14/17
 - This is no longer in the correct place with the changes to the stem. I rebuilt the front edge to align with the stem properly. This had originally been built without good points anyway
 - In remodeling the SB washstrake I ended up nudging a few points, but actually used more of the originals than the first time around. It seems having the pieces around it helped define what worked and didn't a lot, and this was a poor choice to model early.

- Used the same cutting surfaces to make the hawsehole as before, but moved the surface that created the break up slightly to better match photos.
 - Stern section – 2/16/17
 - Several points missed on bottom SB side of stern. Tm18, 20, 21, 22, 23, 24. However, there was only one possible shooting location for these points, so I built a curve between them and the shooting spot, built a surface through the hull point of the relatively flat transom I have for that area, then extended the surfaces. By using the surface to trim the curves, I have located the correct spot for the points very close to where they should be with the relatively flat transom to work with. Saves 345-347
 - Ended up building a stern chunk with a combination of points and curves taken from the existing hull. It is clear from photos that this chunk extends into the hull, which makes me believe that the hull is in fact hollow or near it in that section. Likely this is here because that was rotted out, and no reason to believe that hole doesn't extend all the way through the hull since it's covered by planks on the inside. I think they would be less likely to patch it this way if it were any other case. Boolean split also only worked this way – wouldn't work with just a chunk missing.
 - For planks, I there's another pine spacer piece inside the stern just like the bow. Built this to get the interior curve, and used the hull lines for exterior curve. Points were pretty well recorded, though I had to nudge a little to line up with my hull/log shape. Virtually no measurements on stern, so anything without points (pine interior pieces etc) had to be estimated.
 - For tiny piece alongside of SB stern side repair block and log, I basically built a very thin solid as that appears more like a strip than a wedge based on photos and the shape of the repair block on the BB side. Some good points on it, but depth was really a matter of interpreting the pieces around it.
 - For strangely shaped repair block below the patch piece noted above, I basically just built it from points from all the pieces around it. They dictated the shape, and it matches the photos and drawings fairly well. As with other repair blocks, I obviously don't know what the inside looks like.
 - Taffrail 2/17/17
 - The taffrail was not recorded well. The points are frequently not where they should be, and at least 6 points clearly missed and were not backstopped when recorded.

- Going to use the points, but then move around a bit to match the photos and measurements. The top edges aren't actually too bad, but the bottom edge points are almost useless. Will use measurements and location relative to hull to better place them.
 - Taffrail is sitting up above the hull right now on the bolts. Will place there at least initially since that's where it was recorded. Can move the solid later if I want.
 - Point TF056 was a clear miss, but the recording location was obvious, so I was able to locate it pretty close by making a plane from similar points. I'm not sure this is accurate, but no less so than points I recreate. It does match the wider hull shape in that area (which I believe may be incorrect so that makes me think it's still not accurate, but works as well as anything else I can do at this point.
 - There is heavy degradation throughout the taffrail. I will construct it basically whole, and nudge points that appear inside from this. No reason to try to build the extremely complex contours of wood degradation. I am building the repair section on the SB side. This looks a little strange, but is one of the only places where I have solid points here, so I will leave it as is.
 - Built repair section by splitting away chunks of the solid, and then filing the entire piece afterwards so the repair and damaged areas have a hard corner on them while the others do not.
- Trim Piece on gunwale, or "washrail" 2/17/17
 - This was not recorded in point, and there are only a couple measures on it, so I will be rebuilding mostly with photos.
 - Seems to be a fairly simple piece running along the top of the gunwale with a very smooth top side. Photo estimates show it to be about .025 m sided when compared to the gunwale. It was measured at .017 height.
 - After trying some things out, filed at .01 tolerance. It's pretty curved, but that seems to match photos as best I can tell.
- Metal Straps 2/17/17
 - The points for these were very close but slightly off the hull. Built basic rectangles from points and from a few measures that were taken, and then projected these lines onto the hull shape.
 - The lines projected onto the hull were pulled out .005m fir thickness, which is estimated from photos. These were built as solids. Will go back and drill holes through them as needed when I address fasteners.
 - Built the one on the stem from photos. No measurements seem to be taken on them.
- Trimming 2/17/17 – 2/18/17

- Futtocks and knees to the hull. Final version of untrimmed is savepoint 360
- Some may need to be actually rebuilt or adjusted though since some appear to be too high on the hull and won't trim correctly.
- Many of them are not splitting right. I think I need to take the interior hull shape, then add the interior wall of the gunwale on top of it and join the edges, then try again. As is, I think it's not getting a clean enough splitting surface.
- Managed to trim the worst offenders, but there are many that show very minor overlap. They are too complex to Boolean split, and even splitting surfaces and then rebuilding along the new lines seems to be limited in its success. These might be better rebuilt unless I can find a better method.
- Splitting worked much better for the knees, though a couple still stubbornly refuse to trim as nicely as I would like.
- Fasteners 2/18/17 2/19/17
 - I've found that these are mostly necessary for weight for Orca. As such, I will not be vacating the space they take up with the smaller pieces, mostly as this seems to be virtually impossible for Rhino to keep track of once I get into the smaller ones. Should not adversely affect the model in any real way.
 - Bolts
 - Only a handful were recorded by total station. The rest I will have to use measures and photos and do the best I can. This is mostly important for weight measurements anyway.
 - For CBT, several measures were taken that do not agree. I will use those taken by Nat Howe which roughly seem to match photos, but will trust measures over photos.
 - CBT seem to be countersunk with rounded heads, and alternate which direction based on plank. Will replicate as well as possible.
 - Used truncated cone solid as closest thing for rounded heads, and used a Boolean difference for the countersinking. Heads made .018m to match squared ones, shaft .008m as recorded, and nuts squared .018 as recorded with .007 estimated height.
 - It appears that not all of the bolts on even the CBT are uniform. I'm going to make them pretty similar rather than trying to model each individually – location and weight are more relevant than the actual bolt head etc. for this project.

- Bolt for centerboard pivot seems to be larger, so will estimate size up from the others.
- Bolts for the metal straps and bow were built with great difficulty. Basically created a line where the bolt runs, then built a pipe around it. On either end, I built a nut and a truncated cone for the end, and then Boolean joined the cone and pipe together and split the nut solid. Took a lot of work to get the alignment down with a lot of rotating in each dimension.
- Recorded bolt on floor 12 missed. Not on floor. Floor point for bolt also missed. Not on floor. Will estimate with photos.
- Bolts through floors and keel fairly well recorded. Built in the same way as others before.
- For the myriad smaller bolts that run throughout Bessie and were largely unrecorded, I will reconstruct with simple pipe shapes as well as possible. This will allow the weight to be relevant for testing purposes. 377 is the last save before this point.
- For floors, almost impossible to say how many are underneath the futtocks. Some are based on breakage that can be seen. I have done as well as possible to follow patterns in putting some there, but not just adding bolts willy nilly. Ideally this will even out with those I add unnecessarily and those I miss in terms of weight they add.
- Futtocks bolts are being reconstructed as best as possible with simple pegs. These are not recorded really, and best as I can tell they are the same as the knees which are shown as bolts through the hull of 6mm diameter. Reconstructing locations from photos.
 - Not able to Boolean split the hull or other scantlings with these – they are too narrow I think and end up connecting when they shouldn't. that's probably okay, they are not going to be taking up a lot of wood mass, so they will not change the equation too much that way.
 - 383 is a good screen shot of this process.
- For mast partner bolts using the same .006m diameter given for futtocks.
- Not recording trenails for the moment. They are not well enough documented, and they will not affect the weight calculations in a meaningful way regardless.
- Taffrail bolt holes are recorded, but seem to be missing bolts. Sticking with philosophy of only modeling what is extant given

what was recorded and there are treenails present to hold it in place.

- Put one bolt in the base of the transom – looks like it originally may have been to hold keel in place, but that section is missing and the bolt stops at the bottom of the hull. Maybe sheered off?
- Nails/Screws
 - Less concerned about shape and placement here than general distribution and quantity. Many of these weren't recorded, and the ones that were weren't recorded very carefully. I will build general shapes placed into locations, and these can be used for weight distribution purposes.
 - CBT appears to have screws holding the smaller pieces onto it. Cannot see many and it is not recorded, so will put in minimum of metal fasteners – treenails might also be used for the larger lower section and I don't want to overweight it.
 - Using rubrail nails as my generic smaller fastener whenever possible since the size was actually recorded. Built a pyramid with the recorded cross section on the end of .002x.004m, and a shank of .05m. shank is estimated and may not be ideal for every spot, but should be a good length for most where the thickness nailed tends to be around .025m.
 - These standard sizes I'm adopting are a little small for a few of the futtock repairs. May need to adjust later. EDIT – adjusted some of the ones on Futtock 10 that were clearly too small. Used my larger washstrake nails.
 - Gunwale nails were done with the average spacing of what was recorded, and then just inserted in the appropriate places facing down into the hull.
 - Rubrail done the same way as the Gunwale. Nails spaced roughly according to the average recorded spacing, and then placed in line with surface. Recorded screws and nails the same for the moment.
 - Gunwale requires a longer nail, and has a large round head. Built a new nail with head of .017 diameter as recorded, and estimated nail is probably about .1mm long to secure it well to the hull.
 - Stringer – used the recorded locations of how many fasteners where, and then placed based on where those pieces (namely futtocks) are, and then rotated in different dimensions to match.
 - Created smaller nails for the stem repair planks which are just quite small. .002m diameter and .03m length. Stem area fasteners basically entirely from photos. There was no recording of nails or

screws in this area, but photos give a pretty good idea on the whole.

- Estimating the nail locations for back deck area. Notes mention that a single beam inside the FWD edge serves as a nailer for the planks.
 - Transom has many nails helping connect the various repair pieces, but not all of them show evidence of fasteners, and none were really recorded. Doing best with photos to place and estimate quantity of metal fasteners present.
- Oarlocks 2/19/17
 - Using the measurements to mark the locations on the gunwale. Will dig them out with Boolean split, and then add cops for the newer ones.
 - Not going to rebuild the extensive damage. No real reason to represent this as is – much more relevant where they are on the vessel and how they have moved.
 - Bungs – 2/19/17
 - Not planning to model these at present. They are present throughout the vessel, but only 3 were recorded with the TS. Their use for thickness and general location is relevant, but not sure they really are that important in the modeling for the moment. Can always return to this as needed if it seems to be more important later.
 - 2/19/17 – Primary model done – Bessie as is at the museum. Would also like to reconstruct more how I believe it was at different stages if possible. Save 402
 - 2/20/17
 - There are some issues with the model, namely that some of my “solids” aren’t actually solids, since they have tiny issues with the edges that won’t resolve. These can be microloops, or other abnormalities, primarily stemming from my extensive use of Boolean split. I went through and fixed these for all solids excepting the hull. Can use the SEEdges tool to find which edges are causing problems.
 - Hull is far too complex, and requires Boolean split to actually build. There are at least 3 microloops present that cannot be remedied without completely redoing one of my four primary hull surfaces, and doing so would likely result in more of them since this is the only process I’ve found to successfully build this shape.
 - Best work around I’ve found – create a very small solid, place over the affected spot, and Boolean union. This can even things out a bit without affecting the shape too much. It’s not elegant. It’s kind of like using a Dutchman or repair block. So there’s some philosophical justification for it.

- Involved manually joining over 170 surfaces.. 410 is with all surfaces joined except problems, and before any Boolean unions. About a thousand naked edges to join give or take a few hundred.
- Ended up completely rebuilding the stern as I believe it should look with fewer weird surfaces. The filler hasn't changed, but there is less in the hull than there was. 415 is fully stitched together minus 6 problem edges.
- 416 is legitimate solid with no naked edges. Still having some trouble with Orca assignment of material. 417 is fixed this, but it does not contain my stern spur. This needs to be put back on in a way that creates a single interior, or manifold solid. That was the issue. Divided interiors do not calculate properly and cannot be used. Went back to the save where I could adjust it before fixing the bad micro edges. Went back and placed .001m spheres over these to boolean into the shape. Finally successful... 419 is a model with solids.

