

**Toward a Broadband Services Delivery Model over Wireless Technologies to
Resource-Constrained Public High Schools in South Africa**

by

Tholo Johannes Pholotho

Submitted in accordance with the requirements for the degree of

MAGISTER OF TECHNOLOGIAE

In the subject

INFORMATION TECHNOLOGY

at the

University of South Africa

Supervisor: Dr. Jabu Mtsweni

July 2017

Declaration

I declare that the dissertation entitled TOWARD A BROADBAND SERVICES DELIVERY MODEL OVER WIRELESS TECHNOLOGIES TO RESOURCE-CONSTRAINED PUBLIC HIGH SCHOOLS IN SOUTH AFRICA is my own work, and that all sources used or quoted in the study have been indicated and acknowledged by means of complete references.

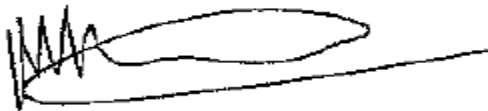

Mr Tholo Pholotho

4 July 2017

Date

Acknowledgements

My first appreciation goes to GOD for his guidance throughout this journey.

My appreciation also goes to my supervisor, Dr Jabu Mtsweni who was always willing to provide me with guidance, suggestions, encouragement and motivation to enable me to complete this work.

I would like to also thank the Senior Manager of Sekhukhune District Municipality with the permission he granted to conduct the research case study in the public schools at Great Tubatse Municipality (GMT).

To the educators from the Greater Tubatse Municipality high schools, I say a million thanks for your contributions to this study.

Without the financial assistance provided by Telkom SA and Armscor through a bursary grant, I would have had difficulty in completing my research.

Finally, I would like to thank my family and colleagues for their patience, support and understanding.

Abstract

Information and Communication Technologies (ICTs) are capable of expanding access to quality education, educational resources, and also provide teachers with new skills. Nevertheless, a majority of rural public schools have limited ICTs, mainly due to geographical landscape, lack of service delivery and poverty. As a result, they currently seem not to be adequately benefiting from current advancements in ICTs. The main objective of this research study was to investigate an appropriate broadband services delivery model using wireless access technologies, such as a Global System for Mobile communication (GSM) and Enhanced data rates for GSM Evolution (EDGE) to deliver electronic-based educational information to resource-constrained public high schools. An exploratory case study approach was adopted to identify and understand the challenges faced by rural schools in the Greater Tubatse Municipality (GTM), including educational services and content considered by the schools as relevant and useful. The research results indicate that resource-constrained schools in the GTM are facing challenges of lack of access to electronic educational information and services, and as a result, teaching and learning becomes limiting and challenging. Based on the research findings, the results show that having access to learning material via electronic platforms could afford educators and learners the opportunity to interact with the outside world, improve learning and teaching and benefit the community as a whole.

The broadband services delivery conceptual model (BSDCM) was proposed, developed and evaluated to address the lack of electronic educational information and services for resource-constrained public high schools. The BSDCM is composed of both technical and non-technical components that consider requirements of all role players, ICT challenges, policy makers and Information Communication Technology for Education (ICT4ED) interventions.

The proposed model addressed some of the challenges regarding lack of access to educational content. However, it is recommended that the ICT4ED policies governing the use of mobile devices in the classrooms be introduced by the relevant authorities. In addition, a comparative analysis of other network technologies should be conducted to establish if the TCP/IP header

compression on Point to Point Protocol (PPP) improves the performance of the network in resource-constrained environments. Furthermore, it is recommended that further research and experiments be conducted to determine if other various third party content providers could create and deploy various educational services and content for different computing platforms using the proposed BSDCM.

Keywords: Broadband, e-Education, Information Communication Technologies, Resource-constrained schools, Greater Tubatse Municipality, Public Schools, Electronic Access, Case Study, Educational Information.

Table of Contents

Declaration.....	1
Acknowledgements.....	2
Abstract.....	3
Table of Contents.....	5
List of Figures.....	10
List of Tables.....	12
List of Abbreviations.....	13
Chapter 1- Introduction.....	17
1.1 Introduction.....	17
1.2 Background.....	18
1.3 Problem Statement.....	20
1.4 Research Questions.....	21
1.5 The Goal and Objectives of the Study.....	22
1.6 Overview of Research Methodology.....	24
1.7 Significance of the Study.....	24
1.8 Scope and Limitations.....	25
1.9 Ethical Considerations.....	25
1.10 Dissertation Chapter Outline.....	26
1.11 Chapter Summary.....	28
Chapter 2- Use of ICTs in Education: South African Context.....	29
2.1 Introduction.....	29
2.2 ICTs in Education.....	30
2.2.1 Importance of Using ICTs in Education.....	30
2.2.2 Content and Services Considered as Relevant for Teaching and Learning.....	33
2.2.3 Challenges Regarding Lack of ICTs in Rural Public Schools.....	35
2.3 Broadband Penetration in the Rural Areas.....	37
2.3.1 Fixed-Line Access Technologies for Rural Deployment in South Africa.....	38
2.3.2 State of Mobile Networks in South African Rural Areas.....	39
2.4 Chapter Summary.....	48
Chapter 3- Mobile Service Delivery Platforms (MSDPs).....	49

3.1	Introduction	49
3.2	Overview of General SDP	50
3.3	Service Delivery Platforms Basic Requirements	52
3.4	Existing Mobile Service Delivery Platforms	54
3.4.1	Mobi4D Platform	54
3.4.2	SPRING Mobile Service Platform.....	57
3.4.3	SPICE Mobile Service Delivery Platform	59
3.4.4	OPUCE Service Delivery Platform	61
3.4.5	IMS Service Delivery Platform	63
3.5	Comparison of Existing MSDPs	65
3.6	Chapter Summary.....	67
Chapter 4- Research Design and Methodology		68
4.1	Introduction	68
4.2	Research Design.....	69
4.3	Research Paradigm.....	70
4.3.1	Relevant Cycle	72
4.3.2	Rigor Cycle	72
4.3.3	Design Cycle.....	73
4.4	The Seven Guidelines for Design Science Research Process	75
4.4.1	Guideline 1: Problem Relevance	75
4.4.2	Guideline 2: Research Rigor.....	76
4.4.3	Guideline 3: Design as an Artefact	76
4.4.4	Guideline 4: Design Evaluation	76
4.4.5	Guideline 5: Design as a Search Process	76
4.4.6	Guideline 6: Research Contribution.....	77
4.4.7	Guideline 7: Communication of Research Outcomes.....	77
4.5	Research Settings	77
4.6	The GTM Case Research	78
4.7	Sampling Technique.....	78
4.8	Data Collection Methods.....	79
4.8.1	Document Analysis.....	80

4.8.2	Direct observation.....	80
4.8.3	Semi-structured Interviews	81
4.9	Data Analysis Technique	82
4.10	Chapter Summary.....	83
Chapter 5	- Case Study Findings	84
5.1	Introduction	84
5.2	Participants Selection	85
5.3	Data Processing and Consolidation.....	86
5.4	Interviews with High School Educators (see Appendix A for the Interview Schedule) 86	
5.4.1	Theme 1: General ICT Requirements for Teaching and Learning	87
5.4.2	Theme 2: The Importance of using ICTs by Teachers and Learners.....	89
5.4.3	Theme 3: Access to ICTs for Teaching and Learning	89
5.4.4	Theme 4: Challenges Faced by High Schools Regarding Lack of Access to ICTs 93	
5.5	Direct Observation Findings	96
5.6	Discussion of Case Study Findings.....	98
5.7	Chapter Summary.....	99
Chapter 6	- Proposed Service Delivery Conceptual Model.....	101
6.1	Introduction	101
6.2	Proposed Model Requirements	102
6.3	Broadband Service Delivery Conceptual Model (BSDCM).....	105
6.3.1	Theme 1 (T1): General ICT Requirements for Teaching and Learning (Educational Services)	107
6.3.2	Applications (Access Mechanism)	107
6.3.3	Theme 2 (T2): Importance of Using ICTs at Public High Schools (Policies and Processes)	108
6.3.4	Theme 3 (T3): Access to ICTs for Teaching and Learning (Existing ICT Infrastructure)	109
6.3.5	Theme 4 (T4): Challenges Faced by High Schools Regarding Lack of Access to ICTs (Challenges).....	109
6.3.6	Required ICT Infrastructure.....	109
6.3.7	Role Players	110
6.3.8	Universal Access (ICT and Education).....	110

6.4	Broadband Service Delivery Architecture for the Implementation of the BSDCM	111
6.4.1	Choice of Access Technology for Implementation	112
6.4.2	Educational Services.....	115
6.4.3	Applications	116
6.4.4	Existing ICT Infrastructure (Devices and Systems)	117
6.4.5	Required ICT Infrastructure.....	118
6.5	Chapter Summary.....	124
Chapter 7- Evaluation of the Proposed Broadband Service Delivery Conceptual Model (BSDCM).....		125
7.1	Introduction	125
7.2	Evaluation of Proposed Model against the SDP Requirements	126
7.3	Experimental Evaluation	130
7.3.1	Building a Test Platform: Network Simulation and Compression Technique	132
7.3.2	Configuring PPP Interface	134
7.3.3	GERAN Adaption and Queue Management.....	136
7.3.4	PPP Compression Technique.....	139
7.4	Measurement of Network Latency after the Compression.....	140
7.4.1	Network latency effects on application performance	142
7.5	Significant of experimental results.....	147
7.6	Comparative Analysis	148
7.7	Chapter Summary.....	150
Chapter 8- Conclusion and Recommendations.....		152
8.1	Introduction	152
8.2	Addressing the Research Problem and Research Objectives	153
8.3	Addressing the Research Questions	154
8.3.1	What Challenges are faced by Resource-Constrained Public High Schools Regarding the Lack of Access to Digital Learning Information?	156
8.3.2	What are the Value-Adding Services and Digital Content Considered by Public High Schools as Relevant and Useful?.....	157
8.3.3	What Broadband Mobile Service Delivery Platforms (MSDPs) are Available to Address Value Adding Services and Digital Content Problems Required by Resource-Constrained Public High Schools?	157

8.3.4	How to Design an Appropriate Broadband Service Delivery Conceptual Model for Seamlessly Delivering Broadband Services (e.g. digital learning information) to Resource-Constrained Public High Schools?	158
8.3.5	How Relevant and Useful is the Proposed Broadband Service Delivery Model as Compared to the others?	159
8.4	Significance and key aspects of Proposed Broadband Service Delivery Model.....	160
8.5	Research Contributions	161
8.6	Limitations of the Study	162
8.7	Recommendations for Future Research	162
8.7.1	Network Technologies	163
8.7.2	Content Access Mechanism.....	163
8.7.3	ICT4ED Policies	164
8.8	Concluding Statements.....	164
	Appendix A-Case Study Interview Schedule	165
	Appendix B- Published Conference Paper	167
	Appendix C- Ethical Clearance	168
	Appendix D- Letter of Permission to Conduct Research at GTM.....	169
	Appendix E- Letter of Proof of Editing	170
9	REFERENCES	171

List of Figures

Figure 1.1: Chapter 1 Layout	17
Figure 1.2: SADC Mobile Subscription Growth (adapted from GSMA Intelligence, 2015)	20
Figure 1.3: The link between the research questions and objectives	23
Figure 2.1: Chapter 2 Layout	29
Figure 2.2: Vodacom EDGE Technology Coverage Map. Source: Vodacom/coverage-map)	40
Figure 2.3: Conceptual diagram to support choice of technology (adapted from Mekuria, 2011).	42
Figure 2.4: Evaluation of Mobile Data Services (Adapted from Wandre, 2000).	42
Figure 2.5: WCDMA (3G) architecture (Adapted from He, n.d.)	44
Figure 2.6: Mobile WiMAX enabling a variety of usage models in the same network (Etemad, 2008)	46
Figure 3.1: Chapter Layout	49
Figure 3.2: General SDP Architecture (Christian & Hanrahan, 2007)	52
Figure 3.3: Simplified Mobi4D architecture (Adapted from Ogunleye <i>et al.</i> , 2011)	56
Figure 3.4: SPRING architecture (Adapted from Bae <i>et al.</i> , 2006).....	58
Figure 3.5: SPICE architecture (Adapted from Tarkoma <i>et al.</i> , 2007).....	59
Figure 3.6 OPUCE platform architecture (Adapted from Yu <i>et al.</i> , 2009)	62
Figure 3.7: Horizontal Service Delivery Platform Architecture (Adapted from O’Connell, 2007)	64
Figure 4.1 Chapter 4 Layout	68
Figure 4.2: Information Systems Research Framework (Adikari <i>et al.</i> , 2009).....	71
Figure 4.3: Design science research cycles.....	71
Figure 5.1: Chapter Layout	84
Figure 5.2: Vandalised telecommunication infrastructures between Jane Furse and in Ga- Malekane village	96
Figure 5.3: Vandalised telecommunication infrastructures in Ga-Malekane village.	97
Figure 6.1: Chapter 6 Layout	101
Figure 6.2: Broadband Service Delivery Conceptual Model (BSDCM)	106
Figure 6.3: Architecture for the Implementation of the Proposed Broadband Service Delivery Conceptual Model.....	112
Figure 6.4: GSM/EDGE Global Footprint (Adapted from Axelsson <i>et al.</i> , 2006).....	114
Figure 6.5: Thin Client-Server Communication	123
Figure 7.1: Chapter 7 Layout	125
Figure 7.2: Network Physical Connection	134
Figure 7.3: Illustration of PPP link Configuration.....	135
Figure 7.4: Network latency after establishing PPP Connection	135
Figure 7.5: Simple Queue Adaption for PPP WAN Interface	137
Figure 7.6: Ping test after Simple Queue Adaption targeted for PPP WAN Interface	138
Figure 7.7: PPP WAN Link Compression	140

Figure 7.8: Network Latency Test after Compression of PPP WAN Link.....	141
Figure 7.9: Web Servers Response Time.....	144
Figure 7.10: Process Followed to Test the Educational Resources Websites.....	145
Figure 7.11: Webserver Page Loading using Dotcom-Monitoring tool	145
Figure 7.12: Webserver Page Loading using Dotcom-Monitoring tool	146
Figure 8.1: Chapter 8 Layout	152
Figure 8.2: Supporting Research Questions.....	159

List of Tables

Table 2.1: Comparison of Technologies for Rural Deployment.....	47
Table 3.1: Solutions Measured Against Criteria Identified (Adapted from Botha <i>et al.</i> , 2010)...	53
Table 3.2: MSDPs comparison against minimum requirements	66
Table 4.1: Mapping of research questions, activities and cycles.....	74
Table 5.1: Access to ICTs and their use for both learners and teachers	90
Table 5.2: Mapping of main themes, research questions and results.....	95
Table 6.1: Requirements developed from case study and MSDP.....	103
Table 7.1: MSDPs comparison against minimum requirements	127
Table 7.2: Evaluation of Proposed Model against the SDP Requirements.....	128
Table 7.3: Network Latency Comparative Results	141
Table 7.4: Comparative Analysis of Proposed Model against the SDP Requirements	150
Table 8.1: Supporting Questions and Objectives Achieved	155
Table 8.2: Summarised challenges of lack of ICTs resource-constrained public high schools..	156
Table 8.3: Direct and Indirect Research Contributions	161

List of Abbreviations

3GPP	Generation Partnership Project
AAA	Authentication, Authorisation, and Accounting
ADSL	Asymmetrical Digital Subscriber Line
API	Application Programming Interface
AS	Application Servers
ASIDI	Accelerated Schools Infrastructure Delivery Initiative
BSC	Base Station Controller
BSDCM	Broadband Service Delivery Conceptual Model
BSDM	Broadband Service Delivery Model
BWA	Broadband Wireless Access
CAD	Computer Aided Design
CAT	Computer Applications Technology
CD-ROMs	Compact Disc- Read Only Memory
CSP	Communication Service Provider
DBE	Department of Basic Education
DNS	Domain Name Server
DOC	Department of Communications
DSR	Design Science Research
DSTV	Digital Satellite Television
EDGE	Enhanced Data Rates for GSM Evolution
EIFL	Electronic Information for Libraries
FP6	Framework Programme
GDP	Gross Domestic Product
GERAN	GSM/EDGE Radio Access Network
GNS3	Graphical Network Simulator
GPRS	General Packet Radio Service
GSM	Global System for Mobile Communication
GTM	Greater Tubatse Municipality

HSPA	High Speed Packet Access
ICMP	Internet Control Message Protocol
ICT4ED	Information Communication Technology for Education
ICTs	Information Communication Technologies
IEEE	Institute of Electrical and Electronics Engineers
IM	Instance Messaging
IMS	Internet Protocol Multimedia Subsystem
IN	Intelligent Networks
IP	Internet Protocol
ISP	Internet Service Providers
IST	Information Society Technologies
IT	Information Technology
ITP	Interactive Teaching Programs
ITU	International Telecommunications Union
JAINSLEE	Java Application Integrated Networks Service Logic Execution Environment
JSLEE	Java Service Logic Execution Environment
JMS	Java Message Service
LAN	Local Area Network
LTSM	Learning and Teaching Support Materials
MAN	Metropolitan Area Networks
MMS	Multimedia Messaging Service
MS	Mobile Station
MSDP	Mobile Service Delivery Platform
MTN	Mobile Telecommunication Network
NDP	National Development Plan
NGN	Next Generation Network
NGO	Non-Governmental Organisation
OMA	Open Mobile Alliance
OPUCE	Open Platform for User-centric service Creation and Execution

OSS/BSS	Operations Support Systems/Business Support Systems
PC	Personal Computer
PDA	Personal Digital Assistant
PLIP	Public Library Innovation Programme
PPP	Point to Point Protocol
PSTN	Public Switched Telephone Network
QCA	Qualitative Comparative Analysis
QoS	Quality of Service
RDP	Remote Desktop Protocol
RNC	Radio Network Controller
RTA	Real-Time Application
SABC	South African Broadcasting Corporation
SA-SAMS	School Administration Management System
SCP	Service Control Point
SDK	Software Development Kit
SDP	Service Delivery Platform
SEE	Service Execution Environment
SLM	Service Lifecycle Management
SIP	Session Initiation Protocol
SMS	Short Message Service
SOA	Service Oriented Architecture
SPICE	Service Platform for Innovative Communication Environment
SPRING	Service Platform for Reconfigurable and Intelligent services in Next Generation
SS-7	Signalling System -7
TCP/IP	Transmission Control Protocol (TCP) over the Internet Protocol (IP)
TELCO	Telecommunications company
TPCK	Technological Pedagogical Content Knowledge
TV	Television
UMTS	Universal Mobile Telecommunications System

UNCTAD	United Nations Conference on Trade and Development
UNESCO	United Nations Educational, Scientific and Cultural Organization
USB	Universal Serial Bus
VAS	Value Added Services
VJHC	Van Jacobson Header Compression
VoIP	Voice over IP
VSAT	Very Small Aperture Terminal
WAN	Wide Area Network
WCDMA	Wideband Code Division Multiplexing
WiMAX	Worldwide Interoperability for Microwave Access
WLAN	Wireless Local Area Network
WWW	World Wide Web

Chapter 1- Introduction

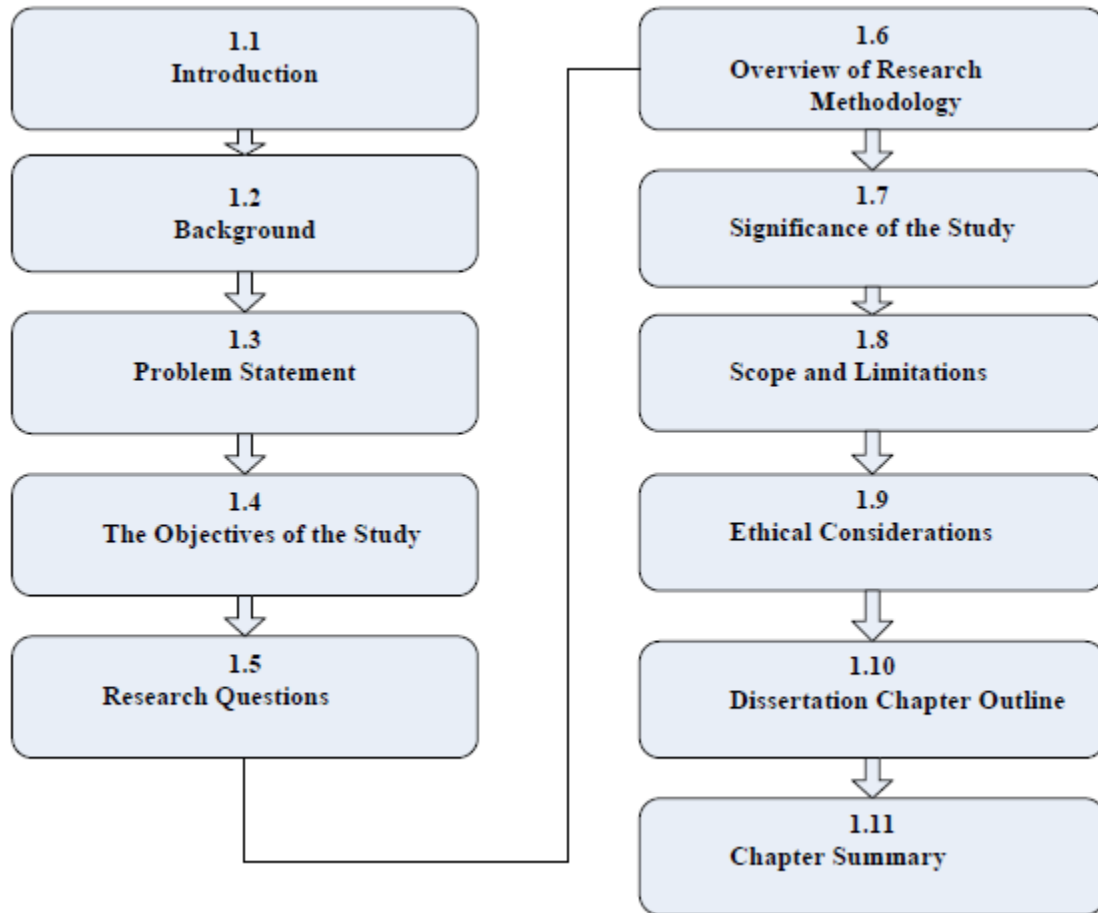

Figure 1.1: Chapter 1 Layout

1.1 Introduction

The main objective of this research study was to investigate the need for and develop an appropriate broadband services delivery model using wireless access technologies, such as Global System for Mobile Communication (GSM) and Enhance Data Rates for GSM Evolution (EDGE) to deliver electronic-based educational information to resource-constrained public high schools. The ultimate goal of the envisaged model is on improving and enhancing access to learning material in electronic platforms by these public high schools. These include access to e-books, videos, learning programs, educational games, and Internet access.

The aim of this chapter is to describe the background to the study and also to describe the problem statement, research questions and objectives of the study. A brief overview of the research methodology adopted and the significance of the study are also introduced. In addition, the scope and limitations of the study conducted are presented. Furthermore, ethical considerations related to the research study are highlighted. The chapter concludes with an overview of the dissertation chapter by chapter. The Chapter is outlined in Figure 1.

1.2 Background

The broadband infrastructure is defined as the network of deployed telecommunication equipment and various technologies to provide high-speed connectivity and other advanced telecommunication services for businesses, private homes, schools, commercial establishments and public institutions (Mkhomazi & Iyamu, 2011; DOC, 2013; Khan, 2015). Drawing from the Broadband Report (2014), the Broadband Commission for Digital Development defines broadband as a high-speed always-on internet access capable to deliver multiple services simultaneously.

The use of high-speed broadband communication networks is becoming an increasingly important part of our daily lives, and most countries encourage the deployment of broadband services and infrastructure so that they could become competitive in the world market (Drago *et al.*, 2012; ITU & UNESCO, 2016; Song, 2016). According to Kennedy *et al.* (2015), broadband connectivity could enhance social equity in terms of education improvement, access to information in digital platforms, economic growth as well as poverty reduction in the rural communities. In addition, broadband penetration will increase the Gross Domestic Product (GDP), new jobs, enhance public service delivery, rural development and the broadening of educational opportunities (DOC, 2013; GSMA Intelligence, 2015).

The research studies by Mkhomazi and Iyamu (2011), Pande and Patel (2012) and Iano *et al.* (2015) have pointed out that in the field of education, broadband connectivity could ease access to digital materials, increase educational opportunities and support the learning process. For example, the adoption of broadband telecommunications in the United State of America (USA) benefited education through the sharing of curricula amongst schools in rural areas (Mkhomazi & Iyamu, 2011). Digital materials can be quickly and easily reproduced, shared and distributed

(Koopman, 2014). In South Africa, broadband and mobile phones could, for instance, assist instructors in the teaching of biology to share lesson plans and pedagogical ideas through social media platforms (ITU & UNESCO, 2015). It is vital to have access to digital materials as there is a huge demand for up-to-date, relevant and contextualised educational material in developing countries (Koopman, 2014).

Many reports and policies have shown that the broadband penetration in South Africa remains limited compared to that of other low to middle-income countries (e.g. North Africa and African island states), particularly in the rural and under-serviced environments (Kennedy *et al.*, 2015; ITU & UNESCO, 2015; ITU & UNESCO, 2016). Ford *et al.* (2014) noted that the large portion of deep rural schools in South Africa are facing many challenges, which includes poor education systems, limited or no access to ICT infrastructure and teaching materials such as textbooks. Khan (2015) also added that the lack of broadband connectivity required by public institutions such as schools impacted negatively on the country's development and global competitiveness.

Rural areas are characterised by low population density, located in the villages, low economic opportunities and the income of the villagers is generally low (Agarwal & De, 2016). The rural area is regarded as a resource-constrained environment (Herselman & Botha, 2014:1). A resource-constrained environment is defined by Anderson *et al.* (2012) as an environment where there are low-income communities and low network bandwidth. A resource-constrained environment provides unique challenges where power and network connectivity are scarce and expensive, and cultures where people are unfamiliar with or afraid of technology (Herselman & Botha, 2014:1). Furthermore, deployment and operations of telecommunication networks in the resource-constrained environment are considered to be challenging and expensive in relation to the return on investment (Mkhomazi & Iyamu, 2011; Agarwal & De, 2016).

Despite the lack of broadband infrastructure in rural areas, the majority of South African rural areas have access to mobile telecommunication infrastructure in the form of GSM and Enhanced Data Rates for GSM Evolution (EDGE) technologies. These technologies account for nearly one-third of total subscribers in the Southern Africa Development Community (SADC) region (Song, 2016). The reports by ITU (2014) and GSMA Intelligence (2015), show that the ownership of mobile phones continues to grow, at the same time a number of developing

countries have been able to leverage mobile technologies to connect under-served areas. Two-thirds of Sub-Saharan Africa’s population has mobile phone reception and one-quarter have access to mobile data services (Song, 2016). Drawing from the SADC mobile subscriber growth report in Figure 1.2, the SADC region, including South Africa has a mobile penetration rate of fifty-four per cent (54%) and seventy-nine per cent (79%) has GSM and EDGE technologies (2G) coverage (GSMA Intelligence, 2016).

SADC subscriber growth

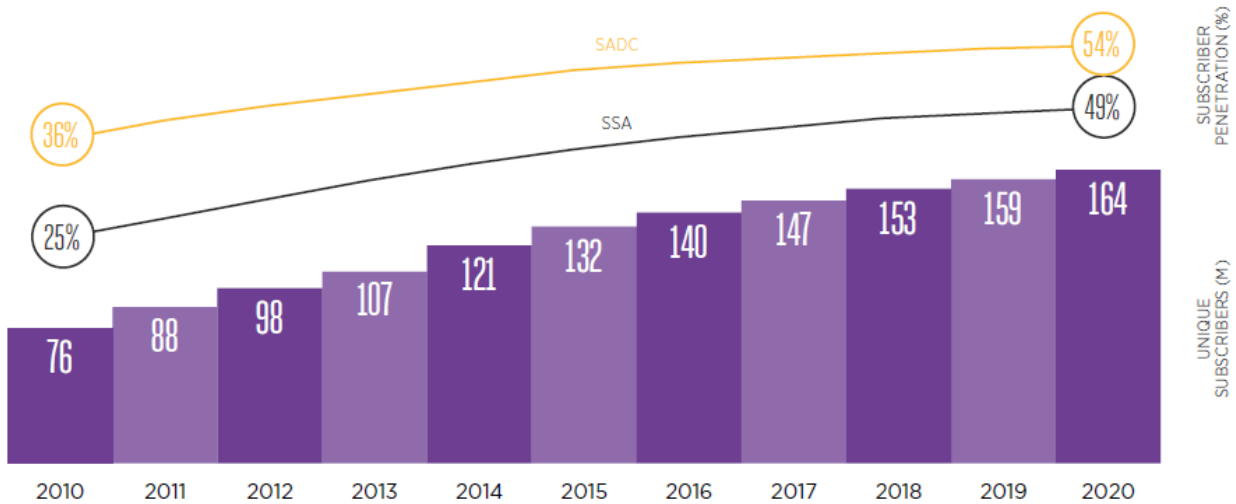

Figure 1.2: SADC Mobile Subscription Growth (adapted from GSMA Intelligence, 2015)

The lack of broadband and ICTs infrastructure in the resource-constrained environment and existing research that indicates how broadband services could potentially increase access to educational information in electronic platforms was the main motivation underlying this research study. The study focused on resource-constrained public high schools under the Greater Tubatse Municipality (GTM) in Limpopo Province of South Africa.

1.3 Problem Statement

Broadband infrastructure is of critical importance to bridge the digital gap between the rural and urban schools in South Africa (Iano *et al.*, 2015; Agarwal & De, 2016). In South Africa, rural and underserved areas, particularly the former homelands have low or non-existing broadband infrastructure (DOC, 2013; Kennedy *et al.*, 2015; RSA Report, 2016).

The broadband infrastructure deployment in the rural regions is hampered by lack of electricity, security, fixed-line deployment costs and maintenance, poverty, lack of technical skills and geographical landscape (Roberts *et al.*, 2015). Africa Connect Policy also articulated that the high prices charged for broadband services are identified as one of the factors hampering South Africa's competitiveness (RSA Report, 2016).

The most current literature presented in Chapter 3 (Section 3.5) has shown that existing Mobile Service Delivery Platforms (MSDPs) requires significant bandwidth, which is still a huge challenge in the rural and developing countries. Furthermore, the majority of the MSDPs evaluated in section 3.5 are very complex and not easy to use for non-skilled end-users, they required highly skilled programmers.

This research study focused on the resource-constrained high schools in the Greater Tubatse Municipality (GTM), Limpopo. These are the schools that have no suitable broadband services delivery model and Information Communication Technologies (ICTs) to address the limitation of access to more learning information on electronic platforms. The researcher focused on public secondary schools because of a high demand for ICT in high schools, and because of the various challenges experienced by the public schools in Limpopo. According to Section 27 (2014), the Limpopo province has the highest levels of poverty and unemployment in South Africa. It also has some of the worst performing public high schools in the country, most of the schools being categorised between Quintile 1–3 by the Department of Basic Education (DBE) (DBE, 2013; Mestry & Ndhlovu, 2014). In addition, a number of challenges have been reported in the media including, challenges with delivery of textbooks suggesting lack of access to educational material and technology (Section 27, 2014).

1.4 Research Questions

In order to achieve the goal highlighted in Section 1.5 the main research question that this study investigated was: *What is the appropriate model for delivering broadband services (e.g. digital learning information) to resource-constrained public high schools in South Africa?*

The main question can be expanded into the following subsidiary questions:

- **Sub-question 1**

What challenges are faced by resource-constrained public high schools regarding the lack of access to digital learning information?

- **Sub-question 2**

What are the value-adding services and digital content considered by South African public high schools as relevant and useful?

- **Sub-question 3**

What broadband Mobile Service Delivery Platforms (MSDPs) are available to address value adding services and digital content problems required by resource-constrained public high schools?

- **Sub-question 4**

How to design an appropriate broadband service delivery conceptual model for seamlessly delivering broadband services (e.g. digital learning information) to resource-constrained public high schools?

- **Sub-question 5**

How relevant and useful is the proposed broadband service delivery model as compared to other existing broadband service delivery models?

1.5 The Goal and Objectives of the Study

The main goal of the research was to identify and develop a broadband services delivery model using GSM and EDGE wireless technologies as the foundation to provide access to digital learning information given the shortage of resources such as telecommunication connectivity, affordability, learning materials and tools, adequate number of educators with expert skills in resource-constrained public high schools.

This goal is fulfilled through the achievement of the specific subsidiary objectives detailed below:

- **Objective 1**

To identify the challenges faced by resource-constrained public high schools regarding the lack of access to digital learning information.

- **Objective 2**

To identify value-adding services and digital content considered by South African public high schools as relevant and useful.

- **Objective 3**

To explore and evaluate the broadband Mobile Service Delivery Platforms (MSDPs) available to address value adding services and content required in the public high schools.

- **Objective 4**

To investigate, design and develop a broadband service delivery conceptual model for delivering broadband services (e.g. digital learning information) to resource-constrained public high schools.

- **Objective 5**

To comparatively and experimentally evaluate the broadband service delivery conceptual model and technical architecture against other broadband-related service delivery models.

In Figure 1.3, the link between the research sub-questions, sub-objectives and main objective are summarised.

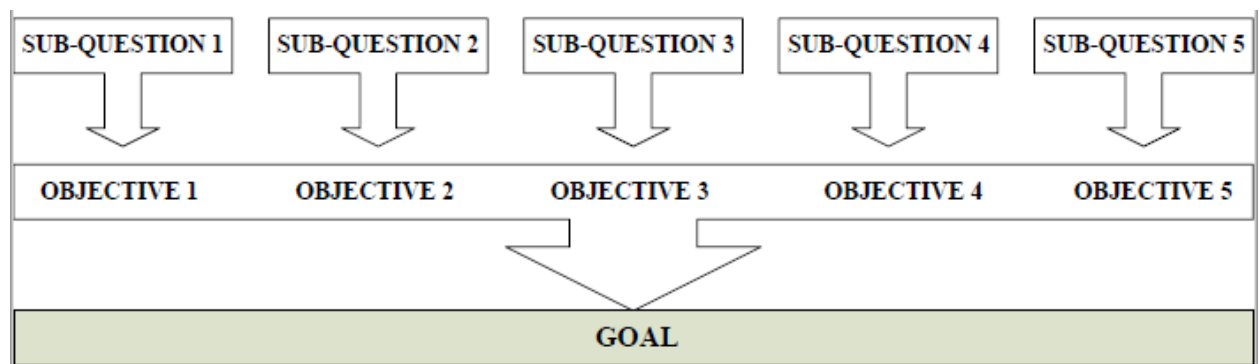

Figure 1.3: The link between the research questions and objectives

1.6 Overview of Research Methodology

The research methodology adopted in this study is discussed in detail in Chapter Four. The research design is mainly of the Design Science Research (DSR) paradigm, which is extensively used as an approach that includes the Design Science Research Process (DSRP) model and pointing clearly the DSR cycles to create artefacts in order to resolve the problem identified in Section 1.3. DSR paradigm, as explained by Hevner *et al.* (2004) and Adikari *et al.* (2009) focuses on creating artefacts to solve the wicked problems. Ford and Herselman (2014:13) citing Hevner & Chatterjee (2010:11) explained that wicked problems relate to the ill-defined environmental context as well as creativity and teamwork to produce solutions.

To gather the requirements of the proposed broadband service delivery model, an exploratory case study approach in the GTM (Chapter Five) and literature review (Chapter Two) was conducted to identify and understand the challenges faced by rural schools, including educational services and content considered by public high schools as relevant and useful. Furthermore, a case study was carried out to examine the state of ICT infrastructure in the GTM. The primary data was collected by means of three methods: Direct observation, documents analysis and semi-structured interview. The high schools and participants were selected using the purposive sampling technique. The method of analysis chosen for this study was a thematic data analysis technique to analyse the qualitative data.

The proposed broadband service delivery model over existing wireless technologies is evaluated against other Mobile Service Delivery Platforms (MSDPs) to determine if it may address the research problem. Furthermore, since resource-constrained environments are quite complex, it was therefore essential to conduct technical evaluations of the proposed model using controlled experiments in a lab environment. The evaluation approach is discussed in Chapter Seven.

1.7 Significance of the Study

The study focuses on identifying and developing a service-delivery model using existing wireless technologies to the resource-constrained environment of Limpopo province. The model will assist in providing connectivity in the public high schools and to ensure access to more learning information and educational expert skills using ICT infrastructure. The findings of this study would contribute to the Department of Education's turnaround plan called *Action Plan 2014*

towards realisation of Schooling 2025 to fast-track the provision of basic infrastructure to schools in the remote areas.

The proposed broadband service delivery model could also be adopted by various organisations such as Internet Service Providers (ISPs) to deliver the digital content and services in the resource-constrained public schools. Furthermore, the findings from the case study will inform other academic communities, policy makers and content providers about the nature of value adding services and content considered useful and relevant by high schools. The study targets the academic community, ISPs, government institutions and policy makers within South Africa.

1.8 Scope and Limitations

- There are number of resource-constrained public schools in South Africa, due to time constraints and travelling resources the study targeted the public high schools located in the Greater Tubatse Municipality (GTM) in the Limpopo province.
- The study focused on secondary data from the literature, particularly those of the education and communication department and other government institutions resources.
- The study focused only on the nature of digital content and services that the South African schools consider as relevant and useful.
- The study only focused on the use of existing wireless access technologies in the GTM such as EDGE and GSM. It is assumed that most resource-constrained areas in South Africa would to some extent have access to GSM and/or EDGE. However, as broadband access improves, it is also expected that broadband access in these areas may also improve.
- The cost and schedule for implementation of proposed broadband service delivery model is not considered in this study.

1.9 Ethical Considerations

The researcher applied for an ethical clearance from UNISA to have official permission to conduct the study and also cover confidentiality and anonymity of participants. After the

clearance was received, the Department of Basic Education (DBE) (Sekhukhune District Municipality) was approached through a letter addressed to the District Senior Manager, after the aim of the research was discussed telephonically. The letter of approval was obtained, and school principals were asked for permission for their teachers to participate in the semi-structured interviews. Once they agreed to participate, the date and times were settled for when the field observations and interviews could be performed. The participants were asked to fill in and sign the consent form which outlined the research purpose. The participants were volunteers and could terminate their participation at any point in the process. They were informed about the recording of interviews. The interviews took between 18 to 33 minutes. The participants and schools will remain anonymous to protect their confidentiality as per ethical clearance conditions.

1.10 Dissertation Chapter Outline

This dissertation consists of eight chapters, they are outlined as follows:

- **Chapter One**

This chapter introduces the background and the motivation for the study. It covers the problem statement, research questions, research objectives, methodology overview, significance of the study, scope and limitations of the research and lastly, ethical considerations.

- **Chapter Two**

This chapter presents a literature review of ICT in education, particularly potential benefits of using ICTs for education; highlights content and services considered by schools for teaching and learning; and, explores the general challenges faced by schools in the rural areas regarding lack of access to ICTs. This chapter further details the state of the broadband penetration in the rural areas in South Africa.

- **Chapter Three**

The third chapter explores the number of existing Mobile Service Delivery Platforms (MSDPs) which could serve as the foundation of proposed model. The MSDPs are later evaluated to establish if they are suitable for deployment in the rural area environment in South Africa.

- **Chapter Four**

This chapter provides a detailed description of the research methodology used in the study. It covers the research design, research paradigm, data analysis techniques, sampling methods, data collection techniques and finally the research setting is described.

- **Chapter Five**

This chapter uses data analysis techniques discussed in Chapter Four to analyse and discuss data obtained from the case study findings. It covers the participants' selection and research limitations of the study, data processing and consolidation. The case study findings are presented and discussed.

- **Chapter Six**

This chapter forms part of the design phase of the research process discussed in Chapter Four. It uses requirements gathered from Chapter Two and addresses the MSDP's limitations discussed in Chapter Three to propose a broadband service delivery conceptual model and architecture suitable for resource-constrained environment deployment.

- **Chapter Seven**

This chapter evaluates the effectiveness of a suitable broadband service delivery model to address the research problem. This chapter evaluates the model in the form of comparative analysis against other models and extensive experiments using network simulations and visualisation tools.

- **Chapter Eight**

The chapter presents the concluding findings of the study, and the suitable broadband delivery model is presented. It also covers the contribution of the study, the research recommendations, suggestions for future research and the author's reflections.

1.11 Chapter Summary

In this chapter, the study was introduced with regard to a general overview of the study, a brief literature review to support the research problem, the research problem, and research objectives. Research questions outlined serve as a basis to understanding the research problem. The research methodology including data collection methods were also outlined in this chapter. The scope and limitations of this study have also been explained. The significance and contribution made by the research study was explained and the organisation of the thesis disclosed.

Chapter 2- Use of ICTs in Education: South African Context

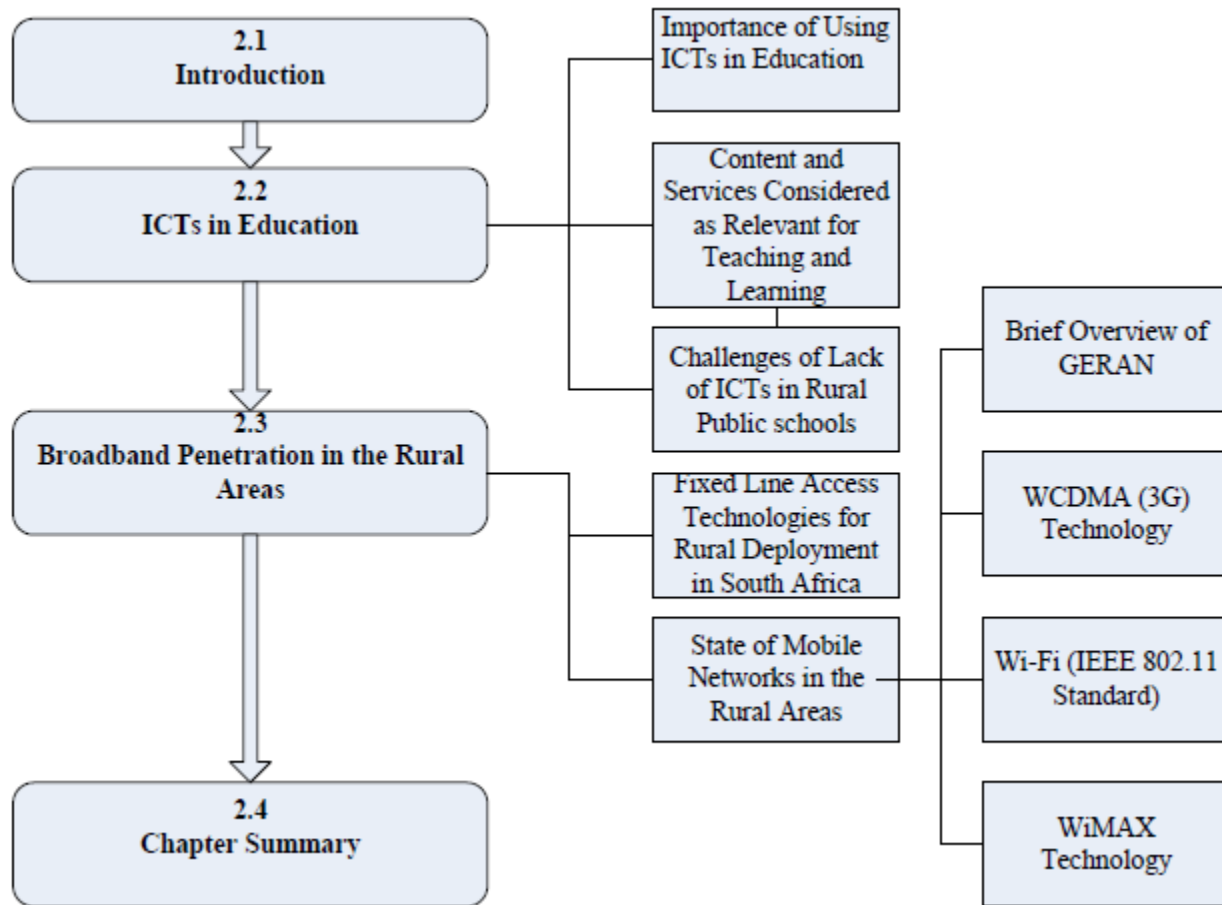

Figure 2.1: Chapter 2 Layout

2.1 Introduction

The primary objective of this literature review chapter is to introduce the use of Information Communication Technologies (ICTs) in public schools in South Africa. This chapter provides a brief review on potential benefits of using ICTs for education; and, highlights content and services considered by schools for teaching and learning. In this chapter, we also explore the general challenges faced by schools in the rural areas in South Africa regarding lack of access to ICTs. The chapter assists in answering two sub-questions:

- *What challenges are faced by resource-constrained public high schools regarding the lack of access to digital learning information?*

- *What are the value-added services and content considered by South African public high schools as relevant and useful?*

This chapter further details the broadband penetration in the rural and underserved areas in South Africa. Various fixed and mobile access technologies for rural deployment are also discussed and evaluated against a list of requirements and challenges listed in Section 2.2.2 and 2.2.3 respectively.

2.2 ICTs in Education

According to South African National Department of Education's e-Education White paper (Department of Education, 2004), ICTs are combinations of networks, software and hardware that enable the processing, management and exchange of data, information and knowledge. In education, the use of ICTs eases access to information and learning resources for both learners and teachers in the schools; further improving teaching and learning (Nkula & Krauss, 2014). The introduction of ICTs into the schools was initially seen as a tool to develop 21st century skills, such as communication, collaboration, critical thinking and problem solving skills (Koopman, 2014). However, today the focus is changing the ICTs to become a tool for teaching and learning (Ford *et al.*, 2014). Non-government organisations (NGOs) such as SchoolNet¹ South Africa (SA) are not only advocating the use of ICTs as the catalyst for change, but they are motivating teachers and senior managers to enhance their teaching approaches (SchoolNet Plan, 2015). The next sub-sections briefly explore the importance of using ICT, including recent developments to support teaching and learning via technology-led innovations in South African schools.

2.2.1 Importance of Using ICTs in Education

Observations by Nkula and Krauss (2014) indicate that, in order to improve the quality of learning and development across South Africa, the government has invested in ICTs in education. To achieve effective outcomes in respect to technology, educators and learners need to accept and utilise ICTs effectively (Mathevula & Uwizeyimana, 2014).

¹ For more information see: <http://www.schoolnet.org.za/>

As Mdlongwa (2012) advised, the integration of ICTs into the school curriculum comes with some of the following benefits:

- Exposure to ICTs would empower learners to become creative in their own right, for example conducting research on their own.
- Introduction of ICTs would allow learners to develop skills that will give them an edge in a technology-saturated work environment.
- A learner who uses ICTs when doing projects begins to develop a culture of independent learning and self-management thus gaining research and communication skills, which are vital in today's work environment.

Findings from a research study by Mathevula and Uwizeyimana (2014) citing, Mikre (2011), reveal that students who use computer tutorials in Natural Science, Mathematics and Social Science subjects score significantly higher marks in tests than those who do not use ICTs. Furthermore, Khumalo *et al.* (2015) argues that the use of ICTs in education contributes to a more constructivist learning approach and an increase in activity and greater responsibility on the part of students. Koopman (2014) also added that the use of ICTs in education will not only improve access to relevant educational materials, but can contribute greatly to the professional development of teachers. Researchers Motsi and Kalema (2015) added that, ICTs have also improved collaboration between learners and educators and within educators themselves.

In South Africa, various government departments in partnership with Non-Government Organisations (NGOs) and other stakeholders introduced a number of programmes and projects to support traditional teaching and learning with ICTs. Some of the recent developments to support teaching and learning via technology-led innovations in South African schools include:

- *SchoolNet Projects*: the project promotes learning and teaching through the use of ICTs in schools. Some SchoolNet projects include supporting teachers through hosting discussions across its social network platforms such as Twitter, Facebook, YouTube and the SchoolNet Blog (SchoolNet Plan, 2015).

- *ICT4RED Project*: ICT for Rural Education Development (ICT4RED) is a sub-project to TECH4RED² (Technology for Rural Education Development) project. The project was initiated by the DBE, Department of Science and Technology (DST) and the Council of Scientific and Industrial Research (CSIR) to improve rural education via technology-led innovation in the Cofimvaba region in Eastern Cape (Botha & Herselman, 2013). The 12-component framework of ICT4RED project has successfully identified the different activities that need to be undertaken in a complex ICT for Education project (Ford *et al.*, 2014).
- *Intel Teach Program*: Intel Teach program sponsors SchoolNet conferences and provides funding for professional development of teachers at selected schools nationally (SchoolNet Plan, 2015). The programme provides participating educators with extensive training to plan projects that promote effective use of ICTs in the classrooms.
- *Google in Education*: the mission of Google in Education and SchoolNet partnership is to develop educators who are using technology for teaching to become Google Certified Teachers (GCT). The ultimate goal of the programme is to improve learning through a web-based literacy technology (SchoolNet Plan, 2015).
- *Microsoft Partners in Learning*³: the Microsoft Partners in learning programme enables school leaders to embrace innovation and implement technology to support teaching and learning (Microsoft Partners in Learning , n.d.).
- *Microsoft Math*: is an educational programme, endorsed by the DST and Nokia, which offer over 10 000 mathematics problems accessible via all types of mobile phones (Broadband Report, 2015). Microsoft Math programme allows learners to do mathematics exercises, read theories, learn from examples and collaborate with other learners.
- *Operation Phakisa ICT in Education Lab*: The programme fast tracks the objectives outlined in the National Development Plan (NDP) (National Planning Commission, 2010). The aim of this initiative is to develop a systematic and detailed roll-out plan for delivery of curriculum through ICT to schools in South Africa (SA News, n.d.).

² More information about TECH4RED initiative is available on: <http://www.ict4red.co.za/about-us/tech4red/>

³ For more information on Microsoft Partners in Learning program see: <http://www.microsoft.com/southafrica/partnersinlearning/default.aspx>

Operation Phakisa lab processed five identified work streams and developed implementation frameworks to address short-term activities and medium to long-term plans.

In addition to the aforementioned interventions, the Department of Basic Education (DBE) introduced programs such as Accelerated Schools Infrastructure Delivery Initiative (ASIDI) to fast-track the provision of basic infrastructure to schools that are currently unable to operate properly due to inadequate infrastructure (DBE, 2011).

Findings from a case study conducted by Chigona *et al.* (2014) in the Western Cape also show that the adoption of ICTs resources in the schools makes teaching easier and engaging. The study also revealed that some educators found the use of ICTs resources in the teaching of Mathematics subjects most rewarding (Chigona *et al.*, 2014). The effect of ICTs adoption in the classrooms in the Gauteng province has also presented many positive outcomes, among which are improvements observed in core subjects such as Geography, English, and Mathematics (Bester & Brand, 2013).

2.2.2 Content and Services Considered as Relevant for Teaching and Learning

Study by Mathevula and Uwizeyimana (2014) suggest that there has been an growth in the use of ICTs to provide teachers with new skills and introducing new methods and practices of teaching in the classrooms. For example, e-learning, engaging in professional circles and searching for educational content on the web. ICTs also expand the access to quality education, access to educational resources that might not otherwise be available in the schools (e.g. online courses and lessons, broadcast media), provide universal primary education in developing countries, boost the literacy and help in preparing learners by developing skills, such as communication, collaboration, critical thinking and problem solving (Nkula & Krauss, 2014).

Nkula and Krauss (2014) also argues that for technology to become a tool for learning and teaching, teachers must also develop a main conception of their subject matter with respect to ICTs and what it means to teach with ICTs. In assisting teachers to develop their teaching with technology and understanding teachers' development toward rich-use of technology, Mishra and Koehler (2006) introduced the technological pedagogical content knowledge (TPCK)

framework. TPCK is a framework to understand the kind of knowledge needed by educators for effective pedagogical practice to implement technology into their classrooms for teaching and learning purposes (Alzain *et al.*, 2014). In South Africa particularly, schools within the country are still behind in the intergration of new technologies into the curriculum (Chigona & Chigona, 2013).

To enhance the traditional forms of educating learners, Mkhomazi and Iyamu (2011) indicated that broadband access could enable the educators to obtain real-time material and use the programs such as:

- Video conferencing;
- Interactive teaching programs (ITP);
- Lessons; and
- Educational gaming.

Bester and Brand (2013) also pointed out that using computer technologies such as CD-ROMs, web browsers, e-mail services, MP3 players, audio-visual facilities, skype and power-point or video recording presentations could promote interactive teaching and learning. In addition, broadband connectivity allows access to services such as video-conferencing facilities, instant messaging (IM) and discussion forums, which could allow pupils and educators to research topics of interest and gain more experience of other countries (Condie & Munro, 2007).

According to a study conducted by Mathevula and Uwizeyimana (2014), cell phone technology enables access to services such as a mobile social networking, Short Message Services (SMS) text messaging and free IM applications for mobile phones and Personal Computers (PCs), which could potentially be used for teaching and learning platforms. The use of tablets and smartphones, which can provide the digital content such as electronic text books has become popular in both developing and developed countries (Ford *et al.*, 2014).

In addition to the adoption of ICTs to enhance teaching and learning in the classroom, ICTs could also ease general school administration and management. In South Africa, the DBE introduced the South African School Administration Management System⁴ (SA-SAMS) for

⁴ More information about SA-SAMS is available on: <http://www.sasams.co.za/>

public schools' curriculum administration, learners and staff management and governance (DBE, 2013). According to Muriithi and Masinde (2016), SA-SAMS is made up of modules that enable the school administrators to:

- Compile annual school surveys;
- Track and record the Learning and Teaching Support Materials (LTSM);
- Capture, track and submit fee receipt to their districts;
- Record basic information about learners, teachers and the school;
- Capture and track learner marks across different subjects; and
- Allocate teaching duties (Time Table).

2.2.3 Challenges Regarding Lack of ICTs in Rural Public Schools

The Department of Basic Education (DBE) acknowledges that there are challenges, which influence the low performance of learners in the South African schooling system, hence the introduction of the turnaround plan called *Action Plan 2014 towards realisation of Schooling 2025* (SADC-AU, 2011).

Khumalo *et al.* (2015) highlighted that poor provisioning of ICT infrastructure, lack of electricity, shortage of educational resources such as computers, let alone access to the Internet, impact negatively on the teaching of science subjects in public schools. Some of the challenges with regard to the use of ICT in classrooms, among others, include fear of change among the users, high cost of technology implementation, maintenance cost and the language used (Walaza *et al.*, 2014).

The study conducted by Herselman (2003) highlighted some of the drawbacks facing rural schools as follows:

- *Lack of skilled and experienced teachers*: this is due to accessibility and availability of appropriate facilities and relevant resources needed for teaching;
- *Lack of telephone facilities*: it will make it possible for rural schools to access Internet and exchange information with their urban counterparts;

- *Lack of stationery and school buildings*: without buildings and stationery, it becomes impossible for learners to receive adequate teaching;
- *Lack of computers*: the computers and its resources are central to modern education, and it is unlikely to find computer laboratories (labs) in most of rural schools; and
- *Remotely situated rural schools*: most of rural schools are located in inaccessible areas, making it difficult to provide resources and facilities.

In a different study by Jere *et al.*, (2013) the following challenges were mentioned:

- Lack of ICT maintenance;
- Shortage of power in the rural schools to operate ICTs;
- Expensive Internet access and equipment;
- No ICT awareness program and ignorance;
- Drastic ICT changes;
- No adequate ICT regulations;
- Lack of ICT literacy; and
- Resistance to technological changes.

Today South African schools are faced with learners who were born in the era of fast growing and advanced technology, therefore access to ICTs is no longer a nice-to-have, but an urgent requirement to facilitate teaching and learning (DBE, 2015).

Literature suggests that schools with ICTs still have challenges, they tend to use ICTs in a limited manner and only focus on learning about computers or acquiring ICT skills rather than putting emphasis on using ICTs to learn (Nkula & Krauss, 2014). This statement was supported by Herselman and Botha (2014:4) who states that teachers in the rural areas are willing to use ICTs for teaching and learning, but they are not qualified in terms of content knowledge and pedagogy. Thus, they are unable to integrate the technology in the classrooms. Mathevula and Uwizeyimana (2014) also argues that, there is a danger that student may be confused by the multiplicity of available information sources from which to choose from. Learners may spend time on websites containing unsolicited contents, such as pornographic material, which could

require teacher to spend much time trying to control students from using websites unrelated to the learning content, instead of focusing on teaching (Mathevula & Uwizeyimana, 2014).

Some of the challenges highlighted in the literature conducted by Chigona *et al.*, (2014) and Nkula and Krauss (2014) suggest that educators who do not feel confident and ready to use ICTs are unlikely to integrate them in their pedagogy. Chigona *et al.* (2014), citing Sherman and Horward (2012), highlighted that some of the educators do not use ICTs in their classrooms because they are computer-phobic⁵. Despite teachers having access to ICTs in some schools, they do not utilise them to deliver the curriculum. In addition, a study by Herselman and Botha (2014:3) has also shown that problems and complexities within South African education system such as ongoing changes to curricula, teachers' under-performance, lack of school leadership and management skills significantly influence the performance of learners, particularly in rural schools.

These findings above are in line the statement in Evoh's (2007), who mentions that “*in order to utilize ICT educational development, it is crucial to train teachers and students, develop content and curriculum, and facilitate community involvement and participation in the implementation process*”.

2.3 Broadband Penetration in the Rural Areas

Many reports have shown that there is slow growth of broadband Internet access in the rural areas, more especially in the developing countries such as those in sub-Saharan Africa (ITU, 2014; ITU & UNESCO. 2015). In many African countries including South Africa, broadband infrastructure penetration is very low and in some areas there is no existence (Kennedy *et al.*, 2015). Research shows 53.3 per cent of South African households has at least one member who can access internet either at home, place of study, internet café or work (Stats SA, 2015). A recent report from GSMA Intelligence (2016), shows that there has been a decline in broadband penetration in the Southern African Development Community (SADC) region, including South Africa. Reading from the South African Connect policy, in the past two decades, South Africa has lost its continental leadership in broadband and internet access (DOC, 2013).

⁵ Computer Phobic is associated with the anxiety about learning to use computers. More information available on: <http://www.igi-global.com/dictionary/computer-phobia/5064>

Providing internet access to the rural areas is seen as a major boost to the Information Communication Technology for Development (ICT4D) activities in every developing country (Dalvit *et al.*, 2014). Setting up the broadband connection in these areas would mean great investment in the e-learning, e-commerce and other economic activities (Khan, 2015). The lack of the broadband infrastructure access to the rural communities will disadvantage these communities to keep up with global development (Dalvit *et al.*, 2014).

Sibanda *et al.* (2008) supported by Huang *et al.* (2012) pointed out the geographical landscape in most of the rural areas as one of the challenges to deploy the networks, because of issues such as valleys, swamps, and mountainous terrain, which make it difficult to deploy the infrastructure. Besides these limitations, the deployment of the network is further hampered by the lack of a reliable energy supplier in some parts of rural areas, as a result, the network operators have to rely on other alternative energy supply schemes, such as solar systems and diesel generators, which are not always efficient or cost-effective (Masonta *et al.*, 2010).

Agarwal and De (2016) also argue that the operation and deployment of telecommunication networks in the rural areas is considered to be challenging and expensive relative to return on investment.

2.3.1 Fixed-Line Access Technologies for Rural Deployment in South Africa

Generally, the fixed-line technology such as copper, coaxial, fibre optic and power cable networks have a high capital infrastructure layout, requiring the deployment of cable links to individual sites at the high cost as compared to wireless technologies (Mlitwa & Ockards, 2008). According to a GSMA Intelligence (2016) report, there is limited fixed-line infrastructure in Sub-Saharan Africa, and where it does exist it is expensive for the local population.

Telkom South Africa (SA)⁶ is currently the only provider of fixed-line affordable broadband connectivity in the form of ADSL (Asymmetrical Digital Subscriber Line) technology in South Africa. The deployment of ADSL is fairly inexpensive in the areas where there is copper wire infrastructure, however, the technology has its own limitations such as the distance, meaning that

⁶ For more information see: <http://www.telkom.co.za>

it cannot reach rural areas due to various challenges described in Section 2.3 (Slabbert & Buys, 2007).

Besides these limitations, copper cable theft has been a major problem in South Africa for many years (Telkom SA, 2014). Despite the decrease of 12,9 per cent in the number of reported cable thefts, breakage and sabotage incidents, each year Telkom SA incurs substantial costs of repairs and maintenance (Telkom SA, 2014). Telkom SA reported 6 000 incidents of theft across its network, with the loss of R200 million during 2015 financial year, due to cable theft (ITWEB, 2016). These thefts cause service repair and deployment delays and have the financial implications, which affect revenue losses (Telkom SA, 2015). Drawing from these reports, deployment of fixed-line broadband infrastructure in the rural areas remains a challenge.

However, there are a number of alternative wireless technologies competing to provide the broadband wireless access in the rural areas. In some cases these technologies can be deployed as the alternative to copper/fibre infrastructure and become effective telecommunication solutions in most of underserved areas (Odhiambo & Kurien, 2009). Various wireless technologies are discussed further in Section 2.3.2 of this study.

2.3.2 State of Mobile Networks in South African Rural Areas

Mobile infrastructure has reached many people in the rural areas of emerging economies before the other basic necessities, such as water and electricity (Louw & Dörflinger, 2010; Stats SA, 2015). Latest reports by ITU (2014) show that a number of developing countries have been able to leverage mobile technologies to overcome fixed-line infrastructure barriers and provide connectivity to previously unconnected areas.

Drawing from a Statistics South Africa (Stats SA) census report cited by Ngyende (2012), the number of households owning cell phones increased from 31,9 per cent in 2001 to 88,9 per cent in 2011 (Ngyende, 2012). The report also indicated that on average, more than 90 per cent of rural households had access to cellular phones in South Africa, and 89.3 per cent were observed in Limpopo province. This confirms that mobile connectivity and accessibility have increased over the years in the resource-constrained environments. The studies by Dalvit *et al.* (2014) and Song (2016) indicated that cell phones are the most popular and accessible ICT devices in South Africa today, particularly in the rural areas. The introduction of cell phones plays a major role in

narrowing the digital divide and they are powerful computing devices that can be used as the potential learning tool in South African schools (ITU & UNESCO, 2015; ITU & UNESCO, 2016). Due to the high cost of fixed-line broadband services, and slow deployment, mobile technologies rapidly became the primary form of broadband access in South Africa (DOC, 2013).

As indicated by Dalvit *et al.* (2014), the majority of communities living in the South African rural areas have access to mobile telecommunications infrastructure in the form of a Global System for mobile communication (GSM) technology. There is also the availability of GPRS (General Packet Radio Service) wherever GSM is available, with EDGE (Enhanced Data rates for GSM Evolution) growing fast (Louw & Dörflinger, 2010). The GPRS is considered as the 2.5 generation technology. It is the standard from the European Telecommunication Standards Institute (ETSI) as a bearer service based on the GSM architecture introduced in 2001, based on Release 97 (Wille & Kok, 2006). This technology is used as the bridge from the voice-centric 2G networks to the data-centric 3G networks and incorporates higher speeds to support data transport at theoretical maximum speed of up to 171.2 k bit/s (EL-Dolil & EL-Safrawey, 2007). Figure 2.2 below depicts Vodacom EDGE coverage map in South Africa.

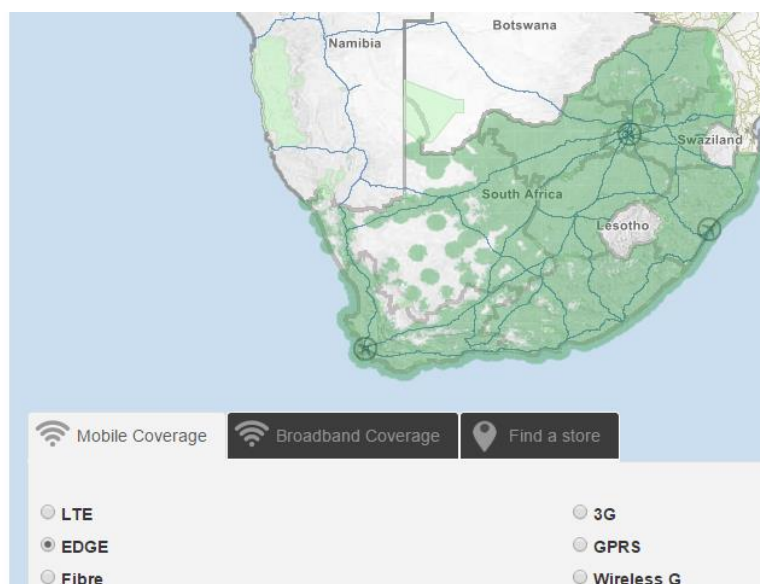

Figure 2.2: Vodacom EDGE Technology Coverage Map. Source: Vodacom/coverage-map

Wille and Kok (2006) have also pointed out that the GSM-EDGE radio access network (GERAN) system was launched to provide the circuit switching voice traffic. However, through the introduction of enhanced GPRS (EGPRS), the systems are able to provide the services which are based on packet switching traffic to ordinary subscribers (Wille & Kok, 2006). The growth of cellular subscription has taken place together with large expansion of access to the Internet and its related multimedia services, which need high speed internet (broadband) and more bandwidth. In order to cope with these demands, Telecommunication Companies need to perform a rapid technology evolution rolling out third-generation (3G) radio access technologies, capable of delivering such services in a cost effective way (Halonen *et al.*, 2004).

There are many wireless technologies that are emerging to possibly provide the broadband wireless access (BWA). However, one has to point out that some of these access technologies are currently not available in some parts of the country, particularly former homelands (DOC, 2013). Some of the key issues that make rural wireless networks deployment challenging are the unreliable power supply, high cost of internet connectivity, distances between nodes, and low technical skill levels of people in the area who need to maintain the networks (Johnson, 2007).

Sibanda *et al.* (2008) state that there are factors that needs to be taken in to consideration when selecting the appropriate wireless solutions. Some of these include the technological capacity, range, noise immunity, noise emission, security, setup and running costs, power consumption, and quality of service (QoS), free versus licensed frequency spectrum, operation, regulations, compatibility with hazardous environment, fault tolerance, technological availability and commercial availability.

In Figure 2.3, Mekuria (2011) describes the conceptual diagram designed to support the choice and optimisation of mobile broadband technologies and services based on quality of service (QoS), energy efficiency, cost, service usability, sustainability, optimisation, rural context and best-fit parameters.

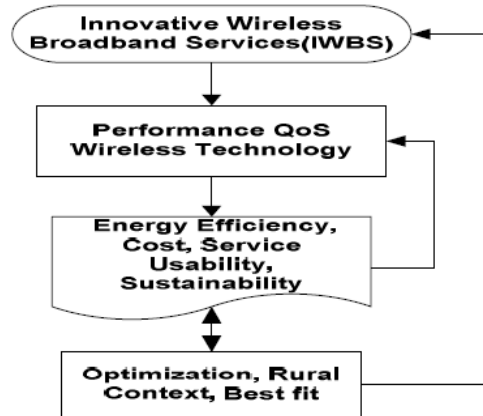

Figure 2.3: Conceptual diagram to support choice of technology (adapted from Mekuria, 2011).

In the next three Sections (Section 2.3.2.1-2.3.2.3), some of the popular wireless technologies suitable for rural deployment are briefly explored to provide context on the mobile and/or network connectivity available in resource-constrained environments. However, it must be pointed out that the discussion of network architectures is beyond the scope of this study.

2.3.2.1 Brief Overview of GERAN

GSM/EDGE Radio Access Network (GERAN) is an evaluation of second (2nd) generation (2G) mobile cellular system based on third Generation Partnership Project (3GPP) release 9 standard (Metsälä & Salmelin, 2012:33). In Figure 2.4, Wandre (2000) presented the evolution of mobile data services.

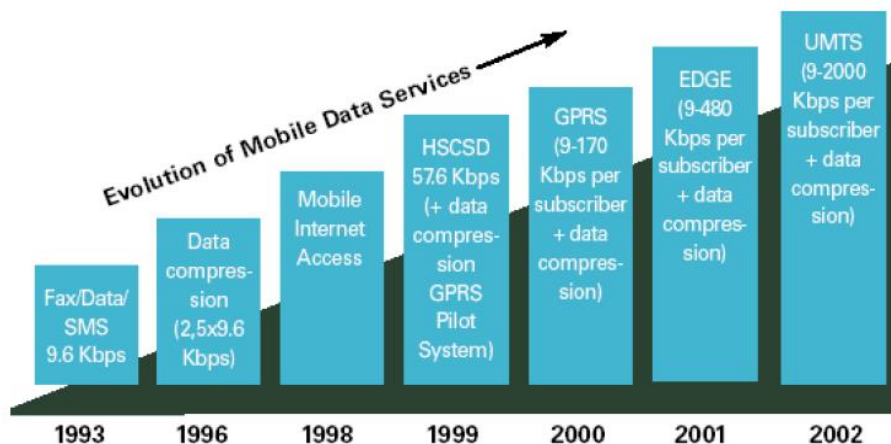

Figure 2.4: Evaluation of Mobile Data Services (Adapted from Wandre, 2000).

The introduction of the GERAN system was seen as a future mechanism to allow operators to adopt combined 2.5G and 3G networks to be able to provide common services regardless of the users location (Proctor, 2003). Furthermore, the goal of GERAN is to boost system capacity for

real-time and best effort services and to compete with other 3G RAN such as Wideband Code Division Multiplexing (WCDMA) (Müller, Sorelius & Turina, 2001). GERAN provides improved support for all quality of service (QoS) classes (Streaming, background, interactive, conversational) defined for UMTS at the theoretical maximum bandwidth provided of 472 kbps (Proctor, 2003; Müller *et al.*, 2012). In addition, Eriksson *et al.* (2000) also outlined the main objectives of standardisation of GERAN as follows:

- To enhance the performance for packet-switching and circuit-switching services.
- To align with Universal Mobile Telecommunications System (UMTS)/3G services related to providing packet based services within EDGE system.
- To interface with an all-Internet Protocol (IP) 3G core network common with UMTS.

2.3.2.2 WCDMA (3G) Technology

Another popular Broadband Wireless Access (BWA) technology is WCDMA (Wideband Code Division Multiple Access). It is the access technique used in a global third generation (3G) mobile communication system, and adopted the ITU standard derived from code division multiplexing access (CDMA) and is mostly used in Universal Mobile Telecommunications System (UMTS) technology (Kang & Sharma, 2011). UMTS is the umbrella term for the third generation radio technologies developed within the Third Generation Partnership Project (3GPP), which includes the whole of the W-CDMA and HSPA (High Speed Packet Access) specifications.

It is based on the GSM standard and employs WCDMA radio access technology to provide greater spectral efficiency and bandwidth to cellular network operators (Cox, 2008). The technology allows users to access multiple services such as video, voice, and data at the high speed on the same frequency. It uses codes to separate users in the same frequency spectrum (Abdelouahed, 2012). WCDMA can also serve as the access network to provide fixed, nomadic, portable and mobile wireless broadband connectivity in the rural and urban areas. The WCDMA network architecture is illustrated in Figure 2.5.

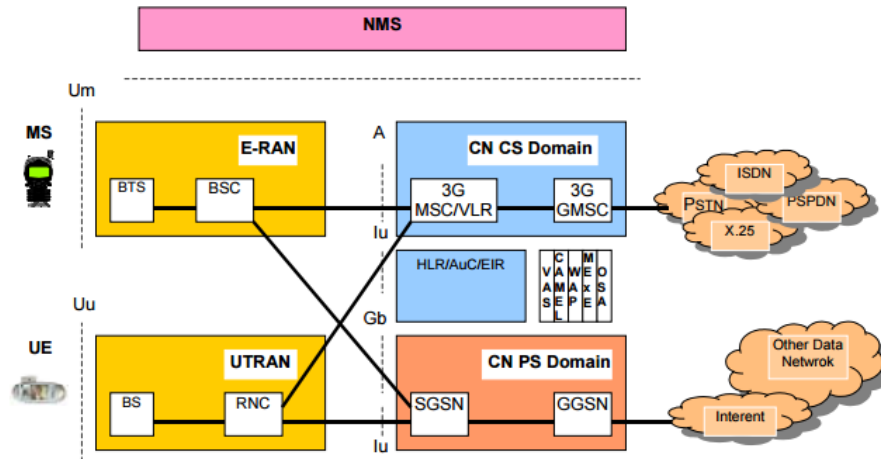

Figure 2.5: WCDMA (3G) architecture (Adapted from He, 2001)

According to Holma and Toskala (2005) , a WCDMA network is capable of providing multiple services. Similar to the WiMAX system, it is possible to deploy a WCDMA system in different geographic areas: rural, urban and suburban, the deployment cost, system coverage, quality and the capacity depends on each area and services required. Holma and Toskala (2005) state some of the services of WCDMA as follows:

- Mobile telephony;
- Fixed PSTN-equivalent telephony;
- Video telephony;
- Basic data services, such as SMS and MMS;
- Advanced mobile data services, such as music downloads;
- Mobile small-screen TV streaming;
- Mobile broadband, targeting laptop users; and
- Fixed wireless broadband (ADSL alternative).

The challenge with WCDMA (3G) technology is that it cannot provide connectivity to large and hard-to-reach geographical areas, due to its inability to address transmissions over multiple frequencies range (Mlitwa & Ockards, 2008). Apart from this and due to use of high frequency, the technology requires approximately twice the number of base stations in the deep rural regions as compared to GSM technology, therefore power efficient base station architectures and alternative energy sources such as solar power are required (Mekuria, 2011). Low and

Dörflinger (2010) highlighted the increase in 3G licenses and international bandwidth as one of the causes of low 3G technology penetration in the rural areas of developing countries.

2.3.2.3 Wi-Fi (IEEE 802.11 Standard)

The IEEE 802.11 standard was adopted in the early 2000s to provide the telecommunication services through WLAN (wireless local area network) hotspots within a range of 200 meters (Gondi & Agoulmine, 2007). The technology enables the devices using radio technology to communicate data anywhere within the range of an access point and also operating in the unlicensed spectrum (Ndlovu *et al.*, 2009).

Sibanda *et al.* (2008) highlighted that the 802.11 technology was initially designed for LAN; hence because of the challenges such as small coverage area, low range and low data rates, it becomes difficult for WAN (Wide Area Network) deployment. Due to its unlicensed spectrum, the Wi-Fi is seen as the low-cost technology to deploy networks in remote communities. It has been deployed successfully in conjunction with WiMAX access technologies in the Dwesa-Cwebe rural community area located in the Eastern Cape (Ndlovu *et al.*, 2009).

2.3.2.4 WiMAX Technology

WiMAX (Worldwide Interoperability for Microwave Access), also known as IEEE Wireless MAN air interface is the 806.16 standard for mobile, portable and fixed Broadband Wireless Access (BWA) in Metropolitan Area Networks (MAN) (Odhiambo *et al.*, 2009). It is an emerging wireless technology for rural and urban deployment, serving large numbers of users at low cost. WiMAX is capable to serve as the backhaul in point to multi point architecture (See Figure 2.6). The technology can support a mix of usage and service models and also serve as the access network to provide fixed, nomadic and mobile wireless broadband connectivity without the need for direct line-of-sight with a base station (Etemad, 2008). It can also provide the broadband connectivity (BWA) to a radius of up to 50km for fixed stations and up to 15km for mobile stations, in cell radius deployment of 3-10 kilometres (Sibanda *et al.*, 2008; Odhiambo *et al.*, 2009).

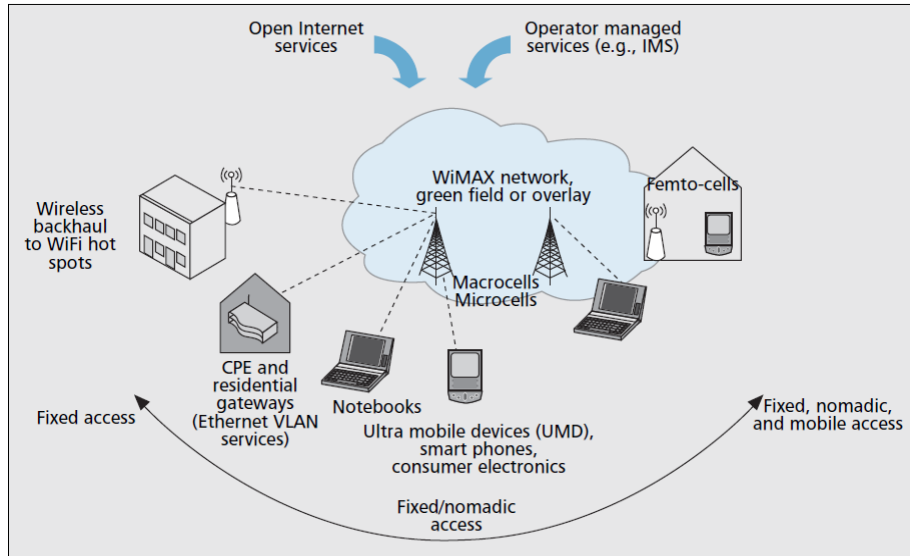

Figure 2.6: Mobile WiMAX enabling a variety of usage models in the same network (Etemad, 2008)

According to Mekuria (2011), the WiMAX technology was designed to extend broadband wireless services to areas without fixed line DSL (Digital Subscriber Line) services. The main advantages of the WiMAX being enhanced coverage, low power consumption, running costs for providing mobile broadband services and the cost associated with licenses can be reduced. Mekuria (2011) has also pointed out that the technology has its own limitations such as high cost of initial deployment, limited end user devices (EUD) and WiMAX PC cards. Zhang (2009) and Al-Adwany (2010) stated the drawbacks of WiMAX as follows:

- *Hesitancy*: WiMAX has not reached widespread use. This makes companies hesitant to set up base stations;
- *Research and development*: without the help of major companies to invest into new products, research and development of WiMAX can be underutilised;
- *Reliability*: When bandwidth is shared amongst the users, the transmission speed is reduced;
- *Climate conditions*: weather conditions, such as rain could interrupt the WiMAX signal;
- *Power consumption*: WiMAX technology requires strong electrical support as it consumes a lot of power;
- *Line of site*: For longer distance connections the line of site is very critical; and
- *Interference*: Other wireless equipment could cause interference.

Table 2.1: Comparison of Technologies for Rural Deployment

Wireless Technologies	Benefits	Drawbacks	Rural Deployment
GERAN	<ul style="list-style-type: none"> • Can interface to an all-Internet Protocol (IP) 3G core network common with UMTS. • GERAN technology is readily available in most parts of the South African rural areas. • GERAN is popularly used, highly available, fast growing and easy to access. 	<ul style="list-style-type: none"> • Limited bandwidth to deliver data rich content. 	√
WCDMA (3G)	<ul style="list-style-type: none"> • Capable of providing multiple services at high speed. • It uses codes to separate users in the same frequency spectrum to avoid interference. • Provides greater spectral efficiency and bandwidth. 	<ul style="list-style-type: none"> • It cannot provide connectivity to large and hard to reach geographical areas. • Due to use of high frequency, the technology requires approximately twice the number of base stations in the deep rural regions • High licence cost. 	√
Wi-Fi (IEEE 802.11 standard)	<ul style="list-style-type: none"> • Low cost technology for remote area deployment. 	<ul style="list-style-type: none"> • Difficult for WAN (Wide Area Network) deployment. • Low range coverage. 	√
WiMAX	<ul style="list-style-type: none"> • Cost associated with operation and licences can be reduced. • Low power consumption, • It can also provide broadband connectivity (BWA) to a radius of up to 50km. 	<ul style="list-style-type: none"> • High cost of initial deployment. • Limited end-user devices (EUD). • WiMAX has not achieved widespread use. 	√

Table 2.1 above summarises the benefits and drawbacks of various wireless technologies for rural deployment. Drawing from Table 2.1, it is evident that most existing technologies can be deployed in the rural environment. It is, however, worth noting that WCDMA (3G), Wi-Fi (IEEE 802.11 standard) and WiMAX technologies have more disadvantages such as deployment cost, sustainability and energy efficiency for rural environments. GERAN technology is highly recommended for resource-constrained environments because of its popularity, high availability, and its fast growing and easy to access technology as opposed to other technologies (Louw & Dörflinger, 2010; DOC, 2013). However, the technology also has some drawbacks such as limited bandwidth to deliver data-rich content. This study focuses on re-using existing technologies such as GERAN to develop a broadband services delivery model to deliver digital educational content for public schools situated in the resource-constrained environment.

2.4 Chapter Summary

This chapter provided an overview of factors that impact on the use of ICTs for teaching and learning. The chapter also identified the technological requirements for teaching and learning, and further explored the challenges faced by high schools regarding lack of access to educational information on electronic platforms. The identified challenges are used as the foundational requirements for the proposed broadband service delivery model. Finally, the chapter discussed the state of the broadband penetration in the rural areas in South Africa and various wireless and fixed-line technologies for rural deployment were explored.

Chapter 3- Mobile Service Delivery Platforms (MSDPs)

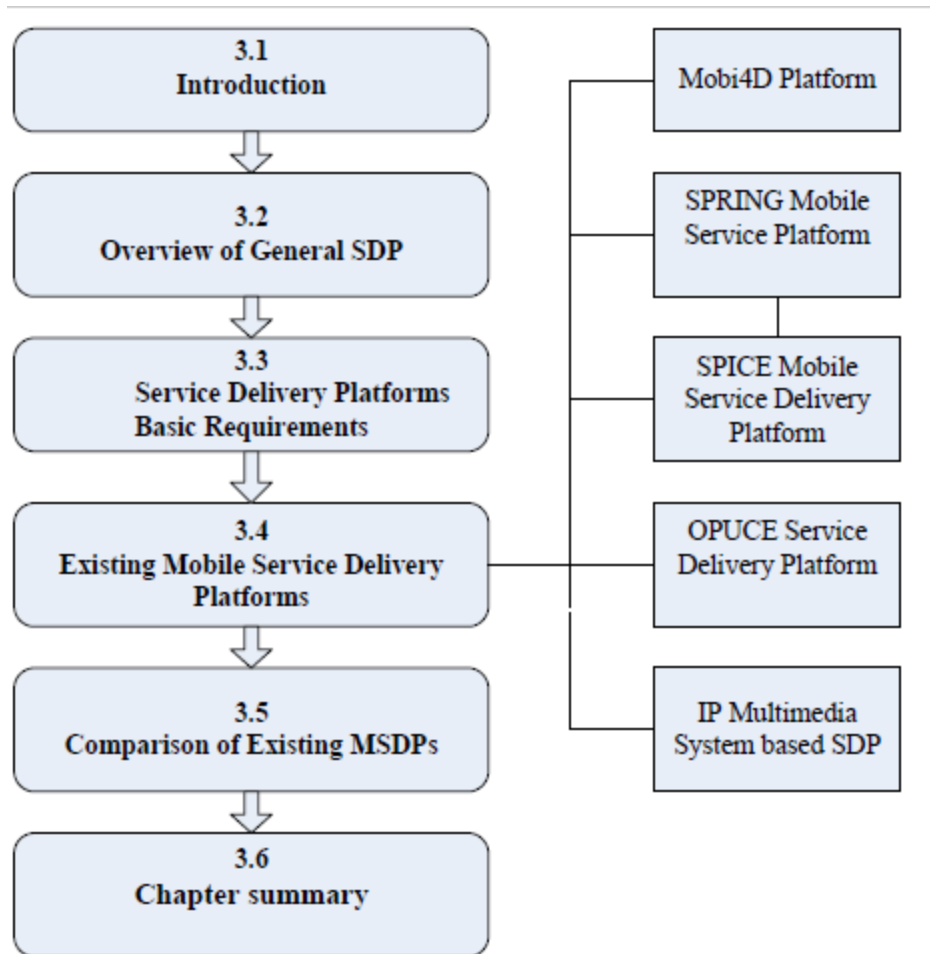

Figure 3.1: Chapter Layout

3.1 Introduction

The purpose of this chapter is to explore and discuss a number of existing Mobile Service Delivery Platforms (MSDPs) that could serve as the foundation of the envisaged model in this study. Drawing on the MSDPs literature, this chapter identifies benefits and limitations of existing MSDPs, specifically focusing on the basic requirements for an effective Service Delivery Platform (SDP). The chapter also compares and evaluates the existing platforms to establish if they are suitable for deployment in resource-constrained environments.

This chapter addresses the subsidiary question:

What broadband Mobile Service Delivery Platforms (MSDPs) are available to address value adding services and digital content problems required by resource-constrained public high schools?

The chapter is structured as follows: in Section 3.2, we define general SDP. The basic requirements of SDP are identified in Section 3.3. The MSDPs are explored in sub-section 3.4.1-3.4.5 and lastly in Section 3.3, the benefits and limitations of MSDPs are summarised. Furthermore, we observe and measure the existing MSDPs to determine how it supports the solution to the research problem identified in this study. MSDPs are compared and measured against the basic minimum requirements identified in Section 3.3.

3.2 Overview of General SDP

Telecommunication (Telco) operators are facing major challenges as new and emerging Internet players are becoming a threat in both new and traditional telecommunication market (Spiess *et al.*, 2014). Furthermore, Sanchez, Carro and Wesner (2008) argue that the new services flooding the market require long development times and redundant work to adapt the logic to the different access networks. Maes (2007) and Lu *et al.* (2008), consider the Service Delivery Platform (SDP) as a middleware platform that can address challenges affecting service providers. The challenges include declining voice revenues, investment of new networks and licences, new competitors entering the Telcos' space and technology and market evolution forcing new investment and need for new services (Maes, 2007).

The Moriana Group (2015) describes SDP as a common service architecture designed to deliver content services such as Web services, real-time content and multimedia (combination of voice, video and data) to the customers. Christian and Hanrahan (2007) further describe SDP as an Information Technology (IT) platform that uses telecommunication (telco) networks to aid service creation and development.

According to Johnston *et al.* (2007), Service Delivery Platforms (SDPs) “*are operators’ solutions that provide a unified middle ground for the optimized exchange of services between users, operators, and service and content providers.*” SDP is made out of components that enable Communication Service Providers (CSPs) to efficiently create, deploy, execute,

orchestrate and manage the services, and it integrates legacy systems easily and flexibly (Lu *et al.*, 2008). SDP is further defined by Maes (2007) as a horizontal platform for the service layer that follows Service Oriented Architecture (SOA) principles; realises the OMA (Open Mobile Alliance) and Service Environment (OSE) to provide an extensible set of mobile voice and communication functions; abstracts underlying network resources and factors out business rules.

Currently, there is no standard for SDP architectures (Moriana Group, 2015). However, Moriana Group (2015) argues that any proposed service platform must have certain characteristics to be classified as an SDP. Christian and Hanrahan (2007) also argue that despite the lack of standardised SDP architectures, various SDP architectures are influenced by vendor, IT and telco-specific technologies. In the case of this study, the envisaged model is influenced by usage of available resources (existing technologies and networks) and current ICTs in resource-constrained environments.

A generalised SDP architecture, adapted from Christian and Hanrahan (2007) is illustrated in Table 3.1 The architecture in Figure 3.2 will be the foundation of envisaged broadband service delivery model, because it contains generic platforms that aim to abstract and simplify telco resources and capabilities, at the same time offering their functions to external third party developers (Christian & Hanrahan, 2007).

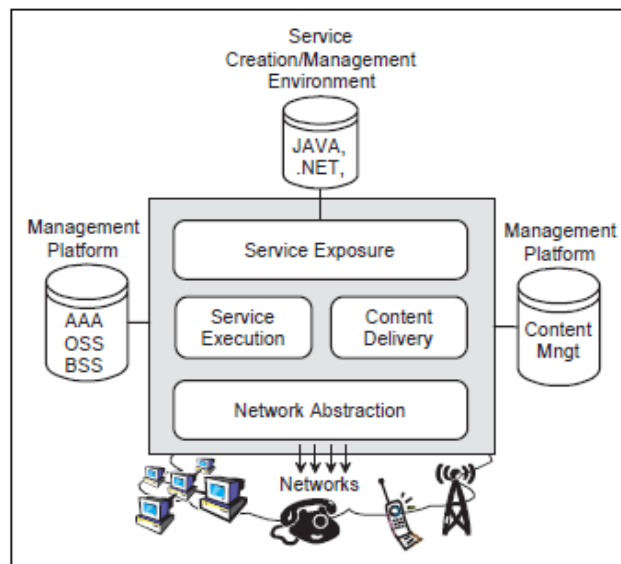

Figure 3.2: General SDP Architecture (Christian & Hanrahan, 2007)

The architecture contains five (5) main platforms as suggested by Christian and Hanrahan (2007).

- *Management Platform*: contains management services that abstract Authentication, Authorisation, and Accounting (AAA) services, and Operations Support Systems/Business Support Systems (OSS/BSS) functionalities.
- *Service Execution Platform*: deploys, executes and manages applications that provide telco services to the end-users.
- *Service Exposure Platform*: defines exposure services that provide secure interface to the SDP to external third party developers with simplified access to all other platforms.
- *Content Delivery platform*: contains content delivery services that provision and deliver content owned by Telcos or content providers to customers.
- *Network Abstraction Platform*: houses technology independent network services that provide access to transport network capabilities.

3.3 Service Delivery Platforms Basic Requirements

The SDPs should meet the basic requirements that lead to efficient (re-) usage of available resources (technologies and networks). According to Botha *et al.* (2010) and Ogunleye *et al.* (2011) feasibility studies, the SDPs should at a minimum meet the following functional and non-functional requirements:

- *Minimal Total Life Cycle Cost*: built using low-cost open-source components;
- *Standard Compliance Solution*: to ensure interoperability, the selected solution should be based on open standards such as SOA;
- *Ease of Use and Accessibility*: Service Delivery Platforms should be easy to create, operate and maintain specific mobile services and reduce required minimum skills levels;
- *Synergies and Interoperability*: SDPs should seamlessly interoperate with other projects and ICT solutions;
- *Bearer and Device Agnostic*: SDPs should allow for the same service to be accessed from different devices using different networks;

- *Reusable Modules*: SDPs should have the capability to develop mobile services using new as well existing re-usable modules;
- *Flexibility and Extendibility*: SDPs need to make it possible to add further communication mechanisms such as Session Initiation Protocol (SIP) and multimedia message services (MMS). In addition, they should have the capability of adding new re-usable service building blocks;
- *Leverage Available Skills*: development and support of the selected solution(s) using the selected SDP should not require scarce skills to support it;
- *Scalability and Availability*: SDPs should be able to meet user load requirements, and ensure high availability.

In Table 3.1, Botha *et al.* (2010) evaluated some of the platforms against the requirements stated above.

Table 3.1: Solutions Measured Against Criteria Identified (Adapted from Botha *et al.*, 2010)

Criteria	OPUCE	SPICE	Twisted	Mobicents	Telco specific
Minimal Total Life cycle	√	√	√	√	Unknown
Standards Compliant Solution	√	√	x	√	Unknown
Bearer & Device Agnostic	√	√	√	√	√
Ease of use and accessibility	√	√	x	x	√
Synergies and Interoperability	√	√	√	√	x
Re-usable modules	√	√	√	√	√
Flexibility & extendibility	√	√	√	√	x
Scalability	√	√	x	√	√
Availability	√	√	x	√	√
Ease of use	√	√	x	x	√
Leverage available skills	x	x	x	√	x

In addition to the minimum requirements of SDPs discussed by Botha *et al.* (2010) and Ogunleye *et al.* (2011), Christian and Hanrahan (2008) further outlined the basic requirements of general SDPs as follows:

- *Service Orientated*: The SDP should manage service creation, provisioning, execution and billing.
- *Use of Current Network Infrastructure*: Should support the delivery of services in a network and devices by abstracting the underlying network infrastructure.
- *Single Standard for Developers*: The SDP should provide a single standardised point for developers to use service enabler and content.
- *IT platform*: The SDP should provide external developers and Information Technology (IT) with open and secure access to Telecommunication (telco) capabilities.

3.4 Existing Mobile Service Delivery Platforms

In this section various Mobile Service Delivery Platforms (MSDP) architectures are explored, briefly discussed and evaluated against the minimum requirements of SDP. Furthermore, the MSDPs are later evaluated in Section 3.5 to establish if they are suitable for deployment in the resource-constrained environments in South Africa. They are evaluated based on benefits and limitations. For the purpose of this study, the existing MSDPs are observed and measured to determine how they support the solution to the research problem identified in Chapter One.

3.4.1 Mobi4D Platform

Makitla and Forgwill (2012) describe Mobi4D as a communication service delivery platform that simplifies the development of mobile value-added services by offering re-usable communication and shared resource components as part of an extendible IP-centric service delivery framework.

The Mobi4D platform empowers non-telecommunication developers to focus on the logic of their services, rather than being concerned about the lower-level technical details of telecommunication protocols (Makitla & Forgwill, 2012). Mobi4D is based on the open source Mobicents and the Java application programming interface (API) for Integrated Networks Service Logic Execution Environment's (JAINSLEE, or JSLEE) specification developed through the Java Community Process (JCP) (Botha *et al.*, 2010).

JAINSLEE defines APIs for application development and signalling protocols (e.g. Session Initiation Protocol (SIP) and Signalling System #7 (SS-7) to be connected as resource adapters

allowing for further network communication mechanisms (Ogunleye *et al.*, 2011). Botha *et al.* (2010) describe Mobi4D as a platform that has an architecture for creating, deploying and managing services and applications by integrating voice, video and data across a range of Internet Protocol (IP) and telecommunication networks. Figure 3.3 shows the simplified Mobi4D MSDP architecture.

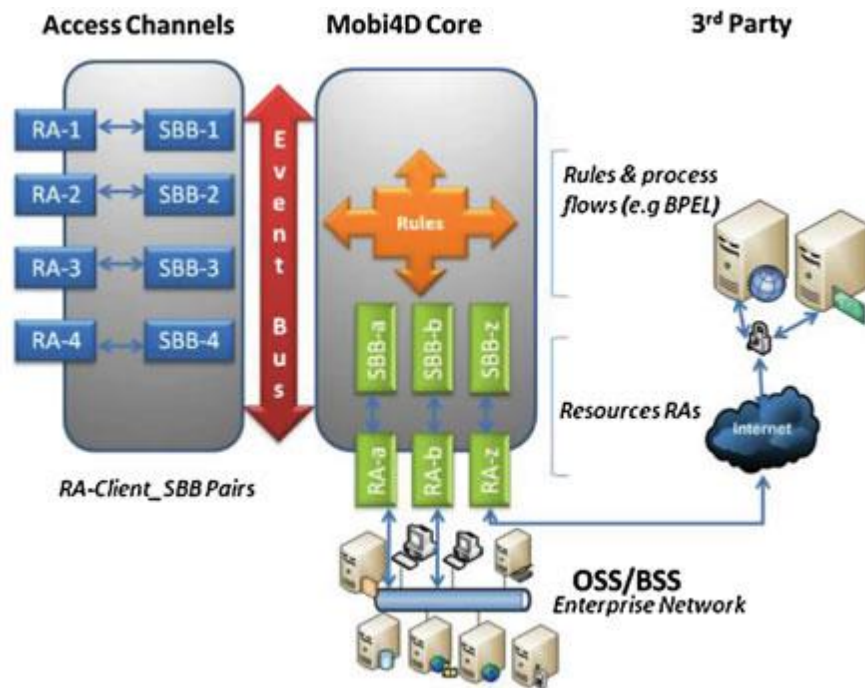

Figure 3.3: Simplified Mobi4D architecture (Adapted from Ogunleye *et al.*, 2011)

The Mobi4D platform does meet some of requirements highlighted by Botha *et al.* (2010) and Ogunleye *et al.* (2011) as discussed in Section 3.3. The benefits of Mobi4D pointed to by Makitla and Forgwil (2012) include:

- *Bearer and Device Agnostic:* Mobi4D is technology-agnostic SDP, allowing users to access to whichever content their devices are able to support. The requests coming into the Mobi4D platform could come from any network and using any protocol.
- *Leverage Available Skills:* Enable non-telecommunication developers to easily and rapidly build mobile applications and services, without focusing on low-level telecommunication protocols.

However, Mobi4D has some limitations (inherent in JAINSLEE) as highlighted by Femminella *et al.* (2009) and Nyathi *et al.* (2013) as follows:

- *Scalability and Performance*: The complexities of the Mobicents JSLEE platform, (which is used by Mobi4D as a platform) and the resources, such as timers and external databases, have a major impact on the platform performance.
- *Java Memory Management*: Java Garbage Collection (GC) behaviour is not under full control of the programmer, and it could pause the running application for unpredictable times, which can compromise the performance of the platform.
- *Synergies and Interoperability*: Mobicents' architecture does not allow third-party applications to communicate directly with components deployed in the container (Nyathi *et al.*, 2013).

3.4.2 SPRING Mobile Service Platform

Service Platform for Reconfigurable and Intelligent services in Next Generation mobile communication (SPRING) platform was designed with a focus on the implementation of a user-centric and service-oriented paradigm of the next generation mobile services (Bae *et al.*, 2006). The SPRING platform is the open source platform to build and run Java applications, which increases productivity, component management and runtime performance (Labor, *et al.*, 2010). According to Bae *et al.* (2006), the platform has been designed to focus on the following key functions:

- Context information management;
- Service and profile management;
- Service mobility support;
- Personalisation;
- Security and privacy;
- Service adaptation; and
- Identity management.

Figure 3.4 shows the architecture of SPRING,

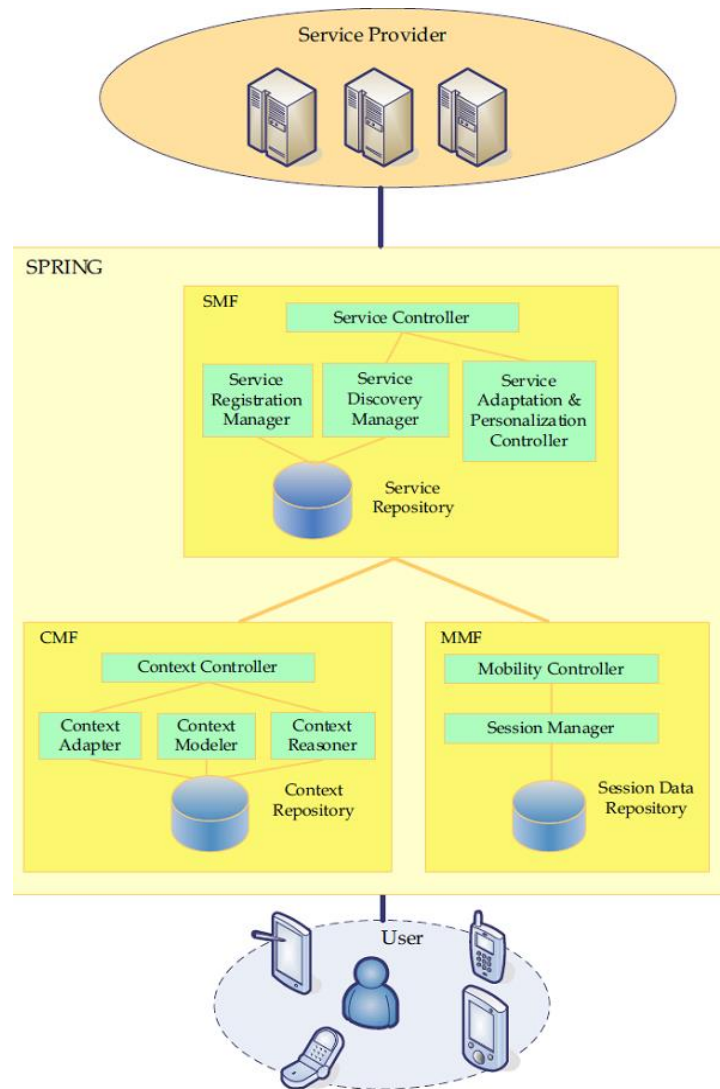

Figure 3.4: SPRING architecture (Adapted from Bae *et al.*, 2006)

Some of the SPRING architecture's strong points highlighted by Labor *et al.* (2010) include: integration with messaging systems via Java Message Service (JMS), Aspect-oriented programming, Inversion of Control and integration with object-relational mapping tools.

Although the platform supports context awareness and personalised services, only service providers can facilitate the provision of a wide variety of services instead of the users (Labor *et al.*, 2010). Therefore, this platform places strict requirements on the part of the end users to be able to build and manage their customised services.

3.4.3 SPICE Mobile Service Delivery Platform

A Service Platform for Innovative Communication Environment (SPICE) SDP was also introduced to meet the requirements highlighted in Section 3.2. The SPICE service platform extends the IP Multimedia Subsystem (IMS) by supporting Value Added Services (VAS) that are composed of more basic services (Tarkoma *et al.*, 2007). SPICE platform adopted standards such as IMS, OSA, and Web services to introduce new mechanisms within the service life cycle process (Bhushan *et al.*, 2007). The objective of SPICE is to hide the complexities of the converged communications environment, and to allow commercial services to be developed and deployed efficiently and economically (Tarkoma *et al.*, 2007).

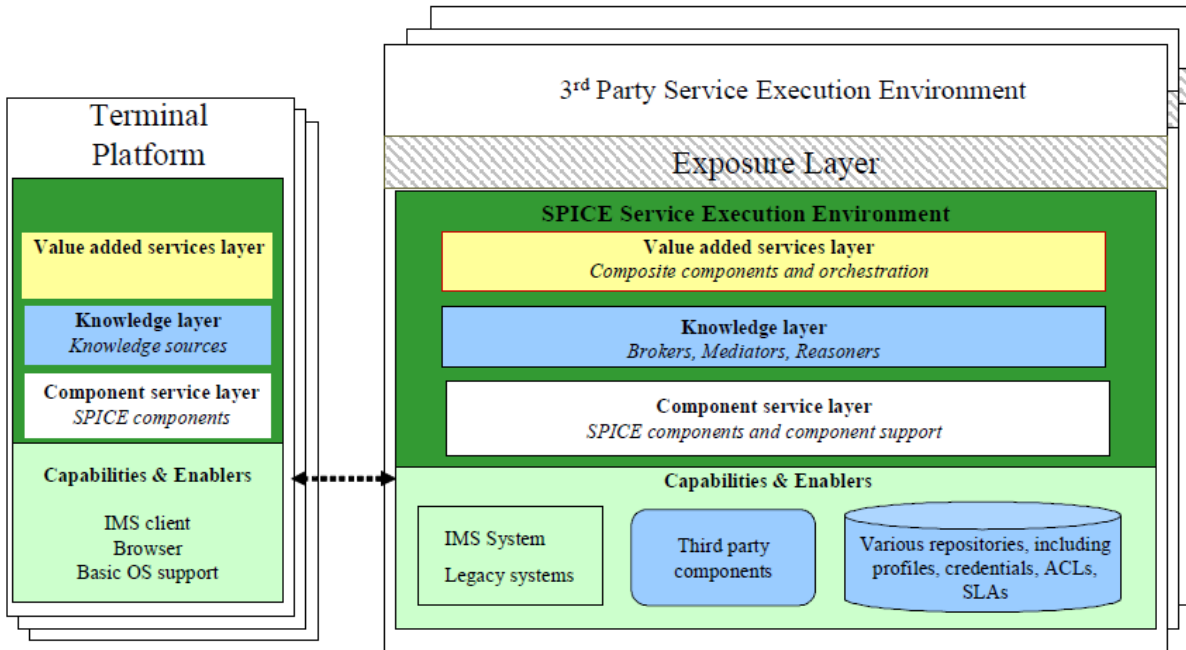

Figure 3.5: SPICE architecture (Adapted from Tarkoma *et al.*, 2007)

Bhushan *et al.* (2007) describe four components of the SPICE platform depicted in Figure 3.5 as follows:

- *Basic Components*: they are generic building blocks that take advantage of SPICE features;
- *Resource Adapter*: is a component that acts as proxy to intergrate other components in legacy systems;

- *Intelligent Components*: they support interfaces from the knowledge framework;
- *Value Added Services (VAS) Components*: can be created at runtime by using real-time information provided by various sources and processed by the knowledge layer components.

The architecture consists of four (4) main layers. Tarkoma *et al.* (2007) and Demeter (2008) summarises them as follows:

- *Capabilities and Enablers' Layer*: consists of external services to provide support functions that realise capabilities such as database storage, protocol stacks, basic signalling and session control;
- *Component Services Layer*: provides facilities for component-based development, deployment and lifecycle management;
- *Knowledge Layer*: This layer supports the discovery, delivery, and transformation of information, such as context and presence variables in the SPICE platform, and finally;
- *Value Added Services (VAS) Layer*: it hosts the value added component and it facilitates the creation of composed components from the basic SPICE components.

According to Cordier *et al.* (2006), the SPICE platform researches prototypes, evaluates architecture and framework for creation and deployment of mobile personalised services and content. Cordier *et al.* (2006) briefly highlighted the some of the following benefits for the SPICE platform:

- Facilitates simple ways to create and roll out the innovation services;
- Enriches current service platform functionality;
- Opens new business model and value chains;
- Provides a simplified and unified model to deliver services over heterogeneous execution networks;
- Promotes the innovation of software technologies in the form of telecommunications platforms.

Similar to the SPRING platform, the SPICE platform also works on several technologies, such as middleware to enable components such as: service brokering, context awareness and mediation mechanism (Tarkoma *et al.*,2007). However, from the user-centred perspective, the information offered by SPICE is lacking. The technological features are too complicated for non technical end-users as the requirement definition process of the platform is too technically-driven (Bergaus, 2015:55-56). In addition, the execution environment of SPICE is also based on JAIN SLEE architecture and, from sub-section 3.2.1 the complexities of the Mobicents JSLEE platform and the resources, such as timers and external databases, have a major impact regarding the platform's performance.

3.4.4 OPUCE Service Delivery Platform

Baladrón *et al.* (2009) describe the Open Platform for User-centric service Creation and Execution (OPUCE) as an integrated project funded under the sixth Framework Programme (FP6) of the European Commission inside the Information Society Technologies (IST) priority. The objectives of the project were to produce a platform that could enable users to easily create, deploy and execute dynamic user-centric services in different environments (Botha *et al.*, 2010). The OPUCE platform allows the end users to merge the traditional basic services with communication capabilities through the user-centric platform, which is supported by Web 2.0 technologies and a user-generated service paradigm (Sanchez *et al.*, 2008; Botha *et al.*, 2010).

Unlike SOA, Parlay-X⁷ and JAIN SLEE paradigms that were telco operators or Internet Service Providers (ISPs) that create telco services in a closed controlled environment, the OPUCE allows non-technically skilled end-users to create and share their own Internet/Telco service Mashups (Sanchez *et al.*, 2008). Furthermore, Sanchez *et al.*, (2008) argue that in OPUCE's context, the basic services such as messaging, calender, address book, call manegement and real-time communications can be accessed anywhere from any device (PC, mobile handset, television, etc.). According to Baladrón *et al.* (2009), the platform is also designed to be accessible by third-party service providers for innovation of open service marketplace business models.

⁷ Parlay-X is a API designed to enable creation of telephony applications as well as to "telecom-enable" IT applications

In Figure 3.6, the general OPUCE architecture and the core sub-systems are briefly illustrated.

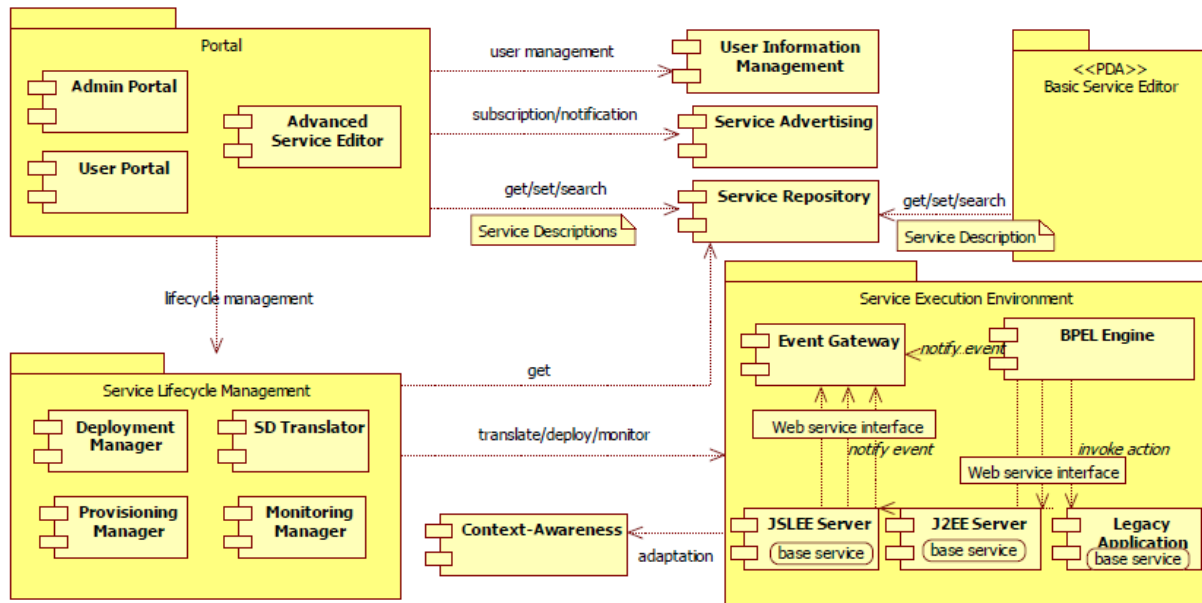

Figure 3.6: OPUCE platform architecture (Adapted from Yu *et al.*, 2009)

Yu *et al.* (2009) describe the main sub-systems of the OPUCE general architecture as follows:

- *Portal:* It integrates the graphical user interfaces of different modules through which users can create and manage services.
- *Mobile/Basic service editor:* It enables end-users to create and edit OPUCE services on devices such as Personal Digital Assistants (PDA).
- *Service Lifecycle Management (SLM):* Manages the lifecycle of all OPUCE services, including provision, monitoring and deployment.
- *Service Execution Environment (SEE):* This system hosts and runs the executable code of both OPUCE base-services and OPUCE services.

OPUCE platform offers significant advantages as compared to service delivery models discussed in this chapter. The OPUCE platform allows end-users to dynamically create personalised services regardless of their environment and location (Wang *et al.*, 2008). Some of the advantages highlighted by Sienel *et al.* (2009) include:

- OPUCE can be used by end-users with no programming skills to build the specific communications application tailored to their needs;

- The platform allows the third party service providers to enter the communications market without requiring big investments for the deployment of new telecommunication infrastructure;
- The service creation tasks can be outsourced, allowing service providers or platform owners to increase customer's satisfaction; and
- It also offers convergent communication services instead of only Information Technology (IT) based capabilities.

Drawing from the Botha *et al.* (2010) and Ogunleye *et al.* (2011) SDPs comparisons shown in Table 3.1 the platform does not meet the leverage skills and technical support requirements.

3.4.5 IMS Service Delivery Platform

Internet Protocol Multimedia System (IMS) is defined by 3rd Generation Partnership Project's (3GPP) as the Next Generation Network (NGN) SDP capable of handling real-time multimedia services such as video, audio, voice and others with the quality of service (QoS) to the customers (Macdonald & Cartas, 2011). Additionally, IMS is defined by Cho and Lee (2010) as the convergence communication environment made up of both fixed and mobile All-IP access networks that can provide digital content with communications, broadcasting and Internet. The IMS-based SDP provides a foundation for the creation, provision, deployment, control, billing and management of services to the customers (Sher & Magedanz, 2007).

According to Macdonald and Cartas (2011), the IMS platform has grown from release 5 to 7 to adopt the following objectives:

- Achieve the paradigm of the mobile internet.
- Combine the latest technological trends.
- Create a mechanism of which the income will be increased due to its use in mobile networks.
- Provide a common platform, in order to allow the creation of multimedia services.

The horizontal SDP architecture for IMS shown in Figure 3.7 depicts three layers, that is layer 1: common service management and provisioning, layer 2: application layer, and layer 3: service enablement layer. This type of architecture was proposed by many Communication Service

Providers (CSPs) to offer innovative services (e.g., enabling the rapid creation and deployment of new services), allow flexibility (e.g., in response to user demand for control over service offering) and to increase the competition (O'Connell, 2007). The three layers are described briefly by O'Connell, (2007) and Filho *et al.* (2008) as follows:

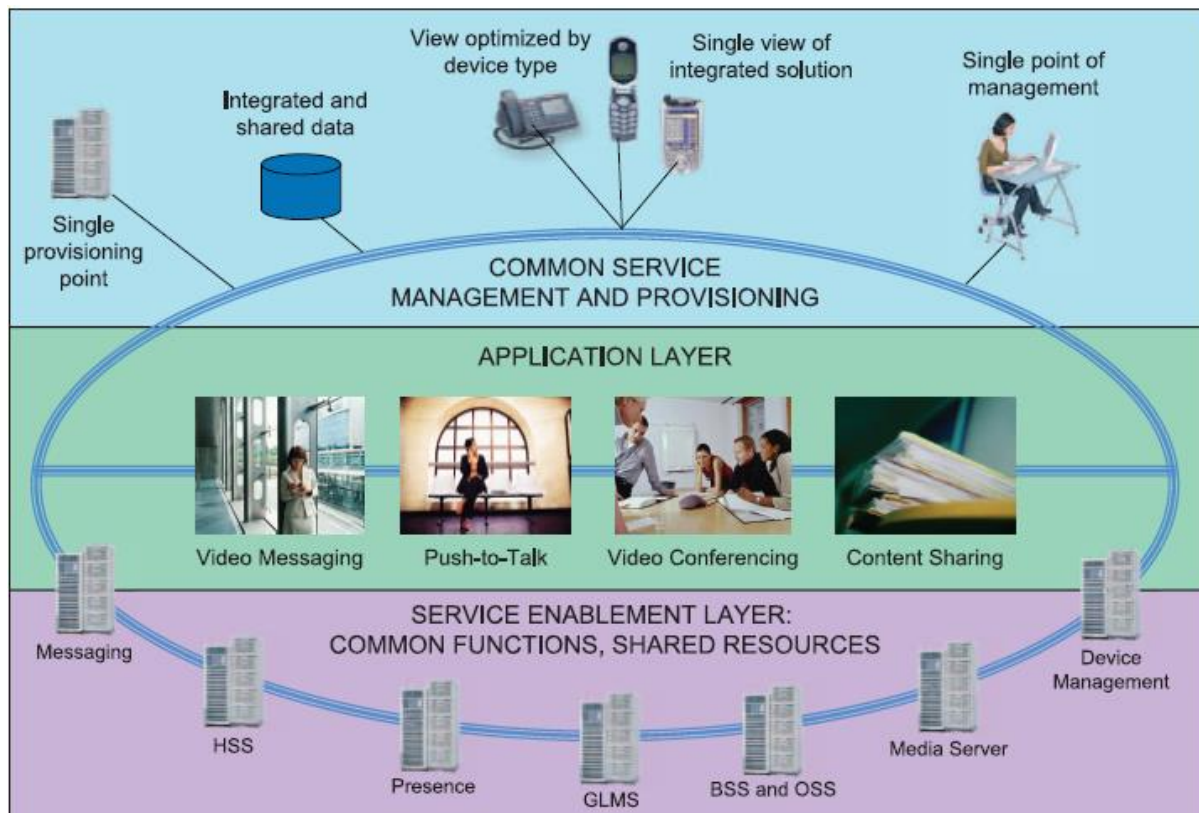

Figure 3.7: Horizontal Service Delivery Platform Architecture (Adapted from O'Connell, 2007)

- *Service Enablement Layer*: hosts a set of application-independent building blocks that offer generic functionality to support a range of multimedia services.
- *Application or Service Layer*: this layer contains application servers (AS) such as SIP (Session Initiation Protocol), third party OSA AS and legacy Service Control Point (SCP) AS to deliver and manage multimedia services.
- *Common Service Management and Provisioning Layer*: the layer adopts common functions for service delivery and common frameworks for service management and provisioning in order to reduce the incremental cost of introducing the new services in to the network.

According to Magedanz and Gouveia (2006), the principal benefits of adopting IMS-based SDP includes:

- Easy and efficient ways to integrate various services;
- Enable third parties to seamlessly integrate the legacy services; and
- Designed to interact consistently with circuit-switching domains.

Although IMS based SDPs bring along the benefits mentioned above, it is worth highlighting that there are some drawbacks in adopting this platform. According to Sienel *et al.* (2009), the architecture of IMS is complex and costly and still does not offer the flexibility that end users expect. Because the IMS is IP-based it does inherit most of security threats that protocols such as SIP and RTP (Real-Time Application) are currently facing (Rebahi et al., 2008). Furthermore, the implementation of IMS in developing countries such as South Africa remains a challenge, IMS service requires significant bandwidth, which is a huge challenge in the rural and developing countries (Pitman & Ventura, 2008).

3.5 Comparison of Existing MSDPs

In this Section, the platforms discussed in subsections 3.2.1-3.2.5 are compared and assessed against the minimum requirements of SDPs listed by Botha *et al.* (2010) and Ogunleye *et al.* (2011). The benefits and drawbacks for each platform are also summarised in this section. Furthermore, the platforms are assessed to establish if they are suitable for deployment in the areas with poor network infrastructure and severely constrained bandwidth. In Table 3.2 existing MSDPs are summarised and compared against the requirements for service delivery platforms relevant in the rural deployment domain.

The existing MSDPs are compared and summarised in Table 3.2 below are considered important when proposing a Service Delivery Platform (Botha *et al.*, 2010; Ogunleye *et al.*, 2011). Table 3.2 below highlights some of the gaps, particularly in the ease of use and accessibility and leverage available skills criteria. The majority of the platforms evaluated are very complex and not easy to use for non-skilled end-users, they required highly skilled programmers.

Table 3.2: MSDPs comparison against minimum requirements

Minimum Requirements	Mobi4D Platform	SPRING Platform	SPICE Platform	OPUCE Platform	IMS based Platform
Minimal total life cycle cost	√	√	√	√	×
Ease of Use and Accessibility	×	×	×	√	×
Synergies and Interoperability	×	√	√	√	√
Bearer and Device Agnostic	√	√	√	√	√
Re-usable Modules	√	Unknown	√	√	√
Flexibility And Extendibility	√	√	√	√	×
Leverage Available Skills	√	×	×	×	×
Scalability	×	√	√	√	√
Availability (from Rural context)	√	×	×	√	×
Performance	×	√	×	√	√

Furthermore, platforms such as SPICE and SPRING are based on all NGN access networks to deliver digital content and multimedia services. However, through the literature review conducted in Chapter Two (Section 2.3) it was highlighted that the broadband penetration in sub-Saharan Africa, particularly in the rural areas is very slow and in many areas it does not exist (ITU, 2014; ITU & UNESCO, 2015). Therefore, the implementation of the next generation SDPs in the rural areas of developing countries such as South Africa is still a challenge.

3.6 Chapter Summary

This chapter presented an overview of the literature on existing Mobile Service Delivery Platforms (MSDPs). The chapter identified the basic minimum requirements that MSDPs should

address. Based on the set of requirements mentioned, the MSDP architectures were briefly discussed and evaluated, focusing on their benefits and drawbacks. Literature searches conducted in this chapter have indicated that many broadband service delivery platforms have some limitations (see Table 3.2) such as complexity, not suitable for rural deployment, not accessible and ease to use and requiring significant bandwidth. The gaps of existing MSDPs identified in this chapter are taken into consideration when designing the envisaged broadband service delivery model.

Chapter 4- Research Design and Methodology

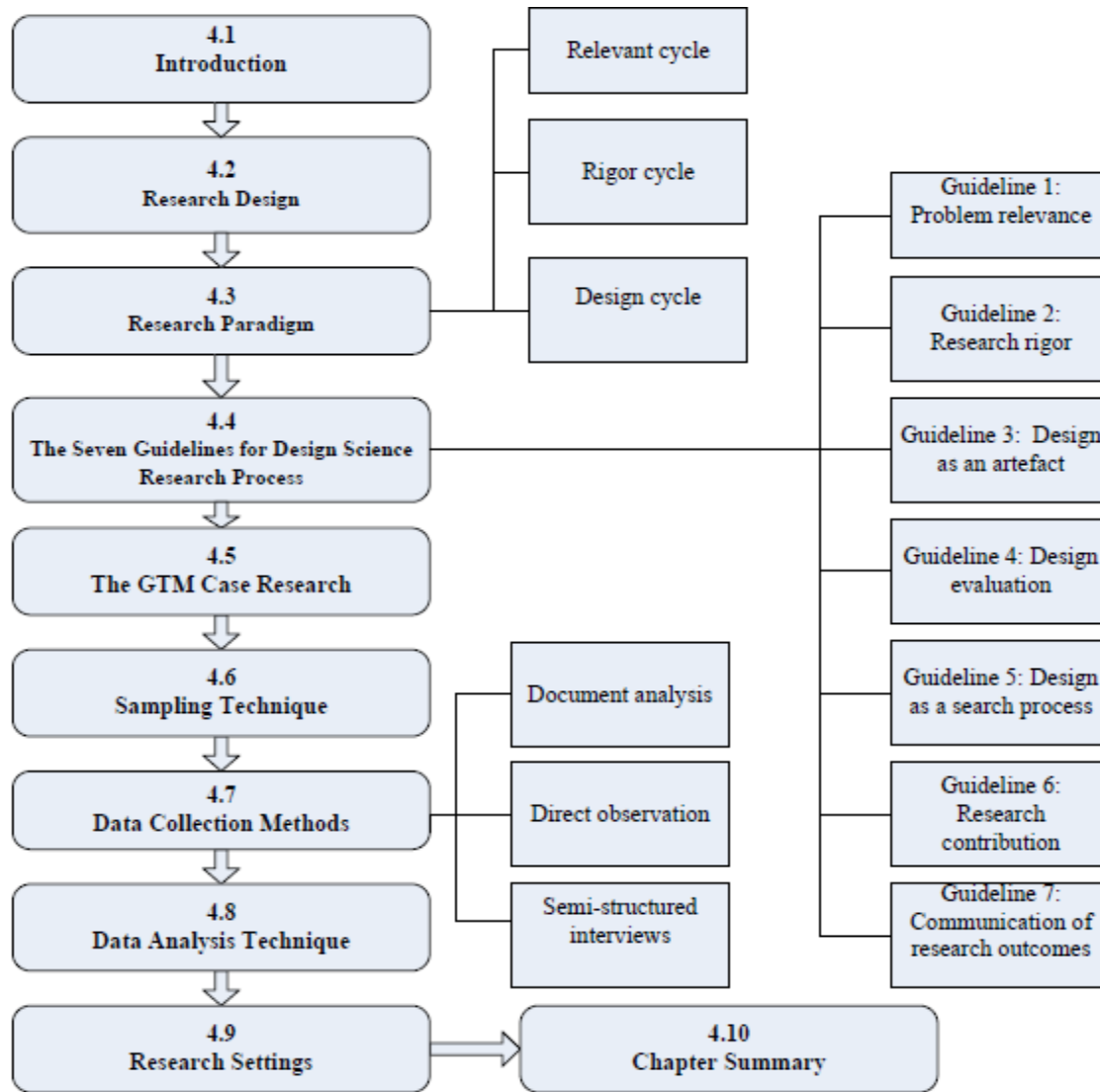

Figure 4.1: Chapter 4 Layout

4.1 Introduction

This chapter details the research methodology and design used in carrying out this study. The methodology is discussed with specific reference to research design and research paradigm (see Section 4.2-4.4). The method of data analysis, sampling technique and the sources used for data collection are also described in Sections 4.5-4.7. Finally, Section 4.9 discusses the aim of

conducting the case study in the Greater Tubatse Municipality (GTM), and explains how it was carried out.

4.2 Research Design

Research is a systematic process of collecting, analysing and interpreting information (data) in order to increase our understanding of the phenomenon about which we are interested or concerned (Leedy & Ormond, 2010). Depending on the main research question, different designs and methodologies would be more or less appropriate to address the identified research problem.

According to Bhattacharjee (2012:35), research design is a comprehensive plan for data collection in research, and it is aimed at answering specific research questions, and the processes include: the data collection process, the instrument development process and sampling process.

This study began with a literature review to identify how broadband services could potentially increase access to more educational information to the high schools in the resource-constrained environments. The literature review approach was initially adopted to investigate what other researchers have found about the lack of Information Communication Technology (ICT) infrastructures in the rural areas. According to Neuman (2011:124), doing the literature review builds on what others have already learned about an issue before you address it on your own.

In the case of this study, the literature was reviewed to explore the benefits of using the Information Communication Technologies (ICTs) and broadband services in the rural public high schools and investigate the infrastructure availability in the form of wireless and fixed-line networks in these areas. The literature has shown that the broadband connectivity can benefit the public high schools in the rural areas; however, there is a slow broadband penetration in public high schools in the rural areas of South Africa due to barriers, such as deployment cost and geographical landscape. The literature study has also shown that there is some communication in the form of Global System for Mobile Communications/ General Packet radio service/ Enhanced Data rates for GSM Evolution (GSM/GPRS/EDGE) technologies in the rural areas.

The main objective of this research study was therefore to investigate and design an appropriate broadband services delivery model using existing wireless access technologies, such as global system for mobile communication (GSM) and Enhanced data rates for GSM Evolution (EDGE) to deliver digital educational information to resource-constrained high schools.

A design science research (DSR) methodology (Adikari *et al.*, 2009) is adopted for the study because it involves creating and evaluating an innovative artefact (e.g. model) that addresses important and relevant organisational problems (Adikari *et al.*, 2009). The design science research paradigm is discussed further in Section 4.3.

4.3 Research Paradigm

In social science, paradigms are mental models or frames (belief systems) of reference that are used to organise our reasoning and observation during the design and conduct of a research study (Bhattacharjee, 2012:17). In Information Systems (IS) research, there are two paradigms: behavioural science and design science. They address fundamental problems faced in the productive application of information technology (IT) (Hevner *et al.*, 2004). The behavioural science paradigm is the origin of natural science and seeks to develop and justify theories (i.e., principles and laws) that explain or predict organizational and human phenomena surrounding the analysis, design, implementation, management, and use of information systems (Hevner *et al.*, 2004).

Hevner *et al.* (2004) and Adikari *et al.* (2009) highlight the design science paradigm as the problem-solving paradigm. The design science paradigm seeks to extend organisational capabilities by creating innovations that define the ideas, practices, technical capabilities and products through the analysis, design, implementation, management, and use of information systems (Adikari *et al.*, 2009).

Adikari *et al.* (2009) further presented a framework that combined both paradigms for understanding, executing, and evaluating IS research (see Figure 4.2).

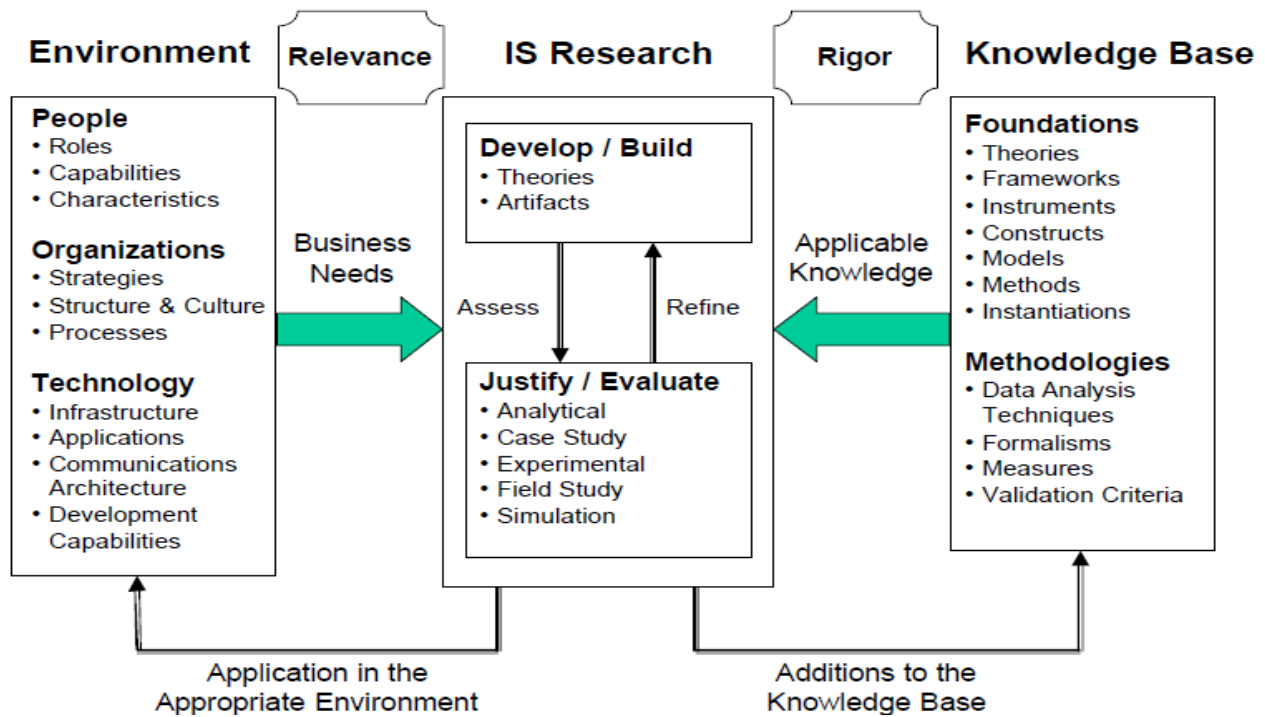

Figure 4.2: Information Systems Research Framework (Adikari *et al.*, 2009)

Within the IS framework, there are three inherent DSR cycles to enhance the understanding of high quality DSR (Adikari *et al.*, 2009). According to Hevner (2007), the three cycles are: Relevant cycle, Design cycle and Rigor cycle. Figure 4.2 illustrates the cycles and these are discussed below.

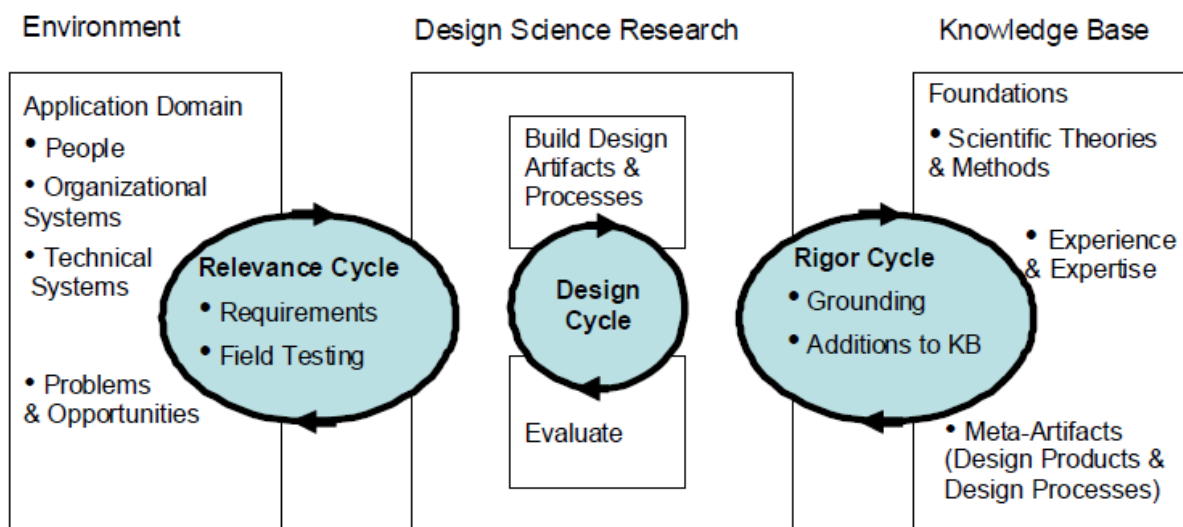

Figure 4.3: Design science research cycles.

4.3.1 Relevant Cycle

The relevance cycle introduces the design solution artefacts to improve the environment, and initiates design science research with an application context that not only provides the requirements for problems to be addressed, but also defines acceptance criteria for the ultimate evaluation of the research results (Hevner, 2007).

In this study, we investigated and developed a model for delivering learning information (i.e. broadband services) using the existing GSM/EDGE (2.5 generation) wireless technologies in the resource-constrained public high schools. In order to deal with the lack of suitable ICT models to address the challenges of access to more learning information and educational expert skills available in electronic platforms, the envisaged model should be evaluated and satisfy the minimum requirements, such as accessibility to digital educational learning materials in the rural high schools.

An exploratory case study was conducted in order to understand the challenges of lack of access to learning information in electronic platforms faced by resource-constrained high schools in Greater Tubatse Municipality (GTM), Limpopo Province, South Africa. The sets of requirements, which the desirable model will meet, were developed from the GTM case study and the literature. The case study is discussed in detail in Section 4.6.

4.3.2 Rigor Cycle

The Rigor cycle connects the design science activities with the knowledge base of scientific theories and engineering methods that provides the foundations for rigorous design science research (Hevner & Chatterjee, 2010:17). The knowledge base is composed of foundations and methodologies; it contains experiences and expertise that define state of the art in the application domain and existing artefacts. It provides past knowledge to the research project to ensure its innovation, but not routine designs based upon the application of well-known processes (Hevner, 2007).

For the knowledge base, Chapter Three of this study focused on an extensive literature review focusing on available broadband service delivery models, frameworks and existing Mobile Service Delivery Platforms (MSDP) and architectures.

4.3.3 Design Cycle

Hevner (2007) describes the internal design cycle as the heart of any design science research project. It generates design alternatives and evaluates the alternatives against requirements until a satisfactory design is achieved. The activities include the construction of an artefact, its evaluation, and feedback to refine the design further. The purpose of the design is to change existing situations into the preferred one (Hevner & Chatterjee, 2010:17).

In this study, the design cycle focused on investigating, developing and evaluating the suitable broadband service delivery model to address the challenges of access to more educational learning information available in electronic platforms using the existing GSM/EDGE (2.5 generation) wireless technologies in the resource-constrained public high schools.

In order to gather the requirements, the study identified the value adding services considered by rural high schools in GTM. These requirements also serve as evaluation criteria for a broadband service delivery model. Table 4.1 indicates the mapping of research questions, activities and cycles for this study.

Table 4.1: Mapping of research questions, activities and cycles

Research questions	Activity	Cycle
<p><i>What challenges are faced by resource-constrained public high schools regarding the lack of access to digital learning information?</i></p> <p><i>What are the value adding services and content considered by South African high schools as relevant and useful?</i></p>	<p>Collect data from published and unpublished materials such as White Papers, government policy documents, financial reports and statistics SA, interviews and field observations to understand the research problem.</p> <p>Conduct the literature review and GTM case study interviews to identify the value adding services used by high schools in South Africa.</p>	<p>Relevant cycle: to connect the environment with design science activities, it focuses requirements and on capturing the problem to be addressed to provide design solution artefacts to the environment in which the study is located for study and evaluation.</p>
<p><i>What broadband Mobile Service Delivery Platforms (MSDPs) are available to address value adding services and digital content problems required by resource-constrained public high schools?</i></p>	<p>Conduct an extensive literature review to analyse available broadband service delivery models that may be suitable to deliver educational information in the resource-constrained environment.</p>	<p>Rigor cycle: it connects the design science activities with the knowledge base, the knowledge base contains experiences, expertise that defines state of the art in the application domain, and existing artefacts.</p>

Research questions	Activity	Cycle
<p><i>How to design an appropriate broadband service delivery conceptual model for seamlessly delivering broadband services (e.g. digital learning information) to resource-constrained public high schools?</i></p>	<p>Adopt a framework to design the conceptual model and technical architecture for implementation.</p>	<p>Design cycle: is the heart of any DSR project. The activities include construction of an artefact and feedback to refine the design further.</p>
<p><i>How relevant and useful is the proposed broadband service delivery model as compared to other existing broadband service delivery models?</i></p>	<p>Conduct technical evaluations of the proposed model using controlled experiments in a lab environment</p>	

4.4 The Seven Guidelines for Design Science Research Process

The fundamental principle of design science research is that knowledge and understanding of a design problem and its solution are acquired in the building and application of an artefact (Hevner *et al.*, 2004). The purpose of these guidelines is to assist researchers to understand the requirements for effective design science research.

4.4.1 Guideline 1: Problem Relevance

This process involves the definition of a specific research problem and justifying the value of the solution. In this study, a research problem was identified within the rural public high schools domain, and is highlighted in Chapter One. The literature review was conducted to investigate the telecommunication infrastructure availability in the form of wireless and fixed line

technologies in the rural areas. Furthermore, the literature was explored to identify the benefits of using broadband services in education.

4.4.2 Guideline 2: Research Rigor

Rigor addresses the methodologies in both the construction and evaluation of designed artefacts. In this study, an extensive literature review was conducted in order to investigate existing Mobile Service Delivery Platforms (MSDP) that could serve as the foundation of an envisaged service delivery model for resource-constrained environments.

4.4.3 Guideline 3: Design as an Artefact

Design science research produces artefacts to address the important organisational problem. Some examples of artefacts include system development methodologies, design tools, and prototype systems. In Chapter Six (see Section 6.3), the design and development of a broadband service delivery model that could be suitable to facilitate access to various broadband information services in the resource-constrained public high schools, using existing GSM/EDGE wireless access technologies is detailed.

4.4.4 Guideline 4: Design Evaluation

In this process, the artefact is observed and measured to determine how it supports the solution to the problem. The proposed broadband service delivery model over existing wireless technologies is evaluated to determine if it may address the limitations of access to more educational learning information available in electronic platforms for the resource-constrained high schools. Furthermore, since resource-constrained environments are quite complex, it was therefore essential to conduct technical evaluations of the proposed model using controlled experiments in a lab environment. The evaluation approach is discussed in Chapter Seven.

4.4.5 Guideline 5: Design as a Search Process

This refers to a process of utilising a set of the actions and resources available to construct a solution while satisfying laws existing in the environment. To meet the requirements, extensive literature was reviewed to search for existing Mobile Service Delivery Platforms (MSDPs) that

could be relevant in facilitating access to digital learning materials (educational content) and other broadband services to resource-constrained areas in the GTM. The model needs to consider the minimum requirements and re-use current GSM/EDGE technologies available in the resource-constrained environments.

4.4.6 Guideline 6: Research Contribution

This guideline entails the outlining of expected outcomes, aims and objectives of the proposed solution to the problem, and this may be quantitative or qualitative. The main objective of the envisaged broadband services delivery model is to address the limitations of access to digital educational learning information and/or services in the resource-constrained environments. The direct and indirect contributions of the research study are explained in Chapter Eight (Section 8.5).

4.4.7 Guideline 7: Communication of Research Outcomes

The outcomes of the research, its value, limitations and lessons learned must be communicated to the various interested audiences. In the case of this study, the communication of the research outcomes is presented in the form of a written dissertation with conclusions and recommendations, and publication of reviewed papers in conference proceedings (see Appendix B-Published Conference Paper).

4.5 Research Settings

The study is focused on resource-constrained high schools situated in the Greater Tubatse Municipality (GTM) of the Sekhukhune District in the Limpopo province⁸. The area of jurisdiction is approximately 4 550 square kilometres in size and is known as the Middelveld (GTM Annual Report, 2013). A large portion of the municipality is rural with approximately 166 villages and six townships. Due to its rural and mountainous nature, it makes the provision and maintenance of services very costly, and is confronted with high service delivery backlogs (GTM Annual Report, 2013). The area is regarded as a resource-constrained environment.

⁸ For more information see: <http://www.tubatse.gov.za/index.php?page=about>

In terms of education, the municipality has 161 primary and 88 secondary schools with 114 723 learners and 3689 educators, and two of the schools are private schools. The schools have inadequate education facilities (GTM Annual Report, 2013). Some of the challenges are shortage of classrooms, lack of basic services such as electricity, water and sanitation.

4.6 The GTM Case Research

According to Bhattacharjee (2012:40) the case research is an in-depth investigation of a problem in one or more real-life settings (case sites) over an extended period of time. The data of those case studies may be collected using a combination of internal or external documents, structured or unstructured interviews, personal direct observation, participant observation and group discussions (Olivier, 2009:98). Case study research needs not to depend on a single source of evidence, but a variety of sources (Yin, 2009:101). This research method is able to discover a wide variety of social, cultural, and political factors potentially related to the phenomenon of interest that may not be known in advance (Bhattacharjee, 2012:40).

Baxter and Jack (2008) describe different types of case studies: explanatory, exploratory, descriptive, multiple case studies, intrinsic, instrumental and collectives. In this study, an exploratory case study was conducted to explore and find out information from the targeted participants, using semi-structured interviews and direct observations. The exploratory case study method was chosen because it can provide insight into a given phenomenon (Bhattacharjee, 2012:6). The case study findings are discussed in detail in Chapter Five. The sampling technique is discussed in the following section.

4.7 Sampling Technique

According to Neuman (2010:240), sampling is the technique of selecting some cases to examine in detail, so that we can learn and understand much about them. Sampling schemes can be classified as representing either random sampling (probability sampling) schemes or non-random sampling (non-probability sampling) schemes (Onwuegbuzie & Leech, 2007).

Types of non-probability sampling include snowballing, purposive, quota and convenience sampling methods. The purposive sampling method is less accurate and does not use random

selection of the population (Neuman, 2010:242). Since this study deals with qualitative data, which gives room for researchers' own discretion, non-probability sampling is viewed as relevant for this research. As such, for the purpose of this study, purposive sampling was adopted. Purposive sampling is based on the assumption that the researcher needs to purposefully select individuals, groups, and settings because they are likely to be relevant, knowledgeable and informative about a phenomenon the researcher is studying (Onwuegbuzie & Leech, 2007).

4.8 Data Collection Methods

Due to the nature of this study, a qualitative approach for data collection was chosen. Bhattacharjee (2012:103) highlights that qualitative research relies mostly on non-numeric data, such as interviews, observations, and content analysis techniques for data collection as opposed to quantitative approaches that are more concerned with numerical data, such as scores and metrics.

Labuschagne (2003) further defines qualitative research methods as producing a wealth of detailed data about a much smaller number of people and cases. The qualitative data consists of a description of situations, events, interactions and observed behaviours from people about their experiences and provides depth and details through direct quotation, correspondence, records and case histories (Labuschagne, 2003).

The qualitative data collection process for this study relied on four research methods: semi-structured interviews, document analysis, direct observation and a literature review. The primary data collection process was achieved by conducting an exploratory case study focusing in the under-serviced high schools situated in the GTM (see results in Section 5.4-5.5). Furthermore, Chapter Two and Chapter Three (in-depth literature review) outlined a brief review on the potential benefits of using ICTs for education; highlighted content and services considered by schools for teaching and learning. In Chapter Three existing established Mobile Service Delivery Platforms (MSDPs) which could serve as the foundation of proposed model was explored. The secondary data was collected from internal and external documents, such as the GTM integrated development plan (IDP), annual reports, census reports and Department of Education White Papers.

4.8.1 Document Analysis

The study is based on both secondary data analysis and primary data collected from other sources such as white papers; policy documents; academic conference papers, journals; financial reports and books in the form of a literature review (see Chapter Two). The literature review was conducted to explore the related work in order to derive the research problem and to answer some the following research sub-questions:

- *What are the value adding services and content considered by South African public high schools as relevant and useful?*
- *What challenges are faced by resource-constrained public high schools regarding the lack access to digital learning information?*

4.8.2 Direct observation

According to Yin (2004), the case study method enables the researcher to make direct observations and collect data in natural settings. The main advantage of direct observation is that an event, institution, facility, or process can be studied in real time, thereby providing richer understating of the case being investigated (Yin, 2009:109).

Taylor-Powell and Steele (1996) suggested that when recording direct observations, one or more of the following means should be taken in to consideration:

- Observation guides;
- Recording sheets or checklist;
- Field notes;
- Pictures; and
- Combinations of observation guides, field notes, pictures and checklist.

The aim of the field observation in this study was to understand challenges faced by resource-constrained high schools in the Greater Tubatse Municipality regarding the lack access to learning information. Furthermore, the state of ICTs infrastructure was also examined. The field

observations enabled the researcher to capture the requirements and clearly understand the problem to be addressed by the new broadband service delivery model.

Ten of the high schools in the GTM were identified for the case study. The identified high schools were selected because they are located in the deep rural areas of GTM. Furthermore, these high schools are experiencing various challenges in terms of basic services and resources (GTM Annual Report, 2013). Out of ten high schools visited, only seven participated in the study. Another two high schools opted not to participate citing that the educators were not available. One of the high schools requested a permission letter from their local circuit offices instead of the one (Sekhukhune district municipality) presented. Due to time constraints and distance, it was impossible to seek an additional permission letter from the local circuit at short notice.

Direct observation data was collected from the high schools when the interviews were carried out. Furthermore, the pictures of vandalised telecommunication infrastructure in the surrounding villages were captured. The researcher's approach to observations was to take field notes paying attention to:

- Access to infrastructure (electricity, school buildings, telecommunication and libraries) and ICTs (computers, scanners, printers etc.) in the high schools;
- Telecommunication Infrastructure availability in the villages located in the GTM; and
- Quality of cellular networks within the visited high schools.

4.8.3 Semi-structured Interviews

Semi-structured interviews are the second research method of primary data collection for this study. Semi-structured interviews are a personalised form of data collection; they give the interviewer the opportunity to clarify any issues raised by the respondent or ask probing or follow-up questions (Bhattacharjee, 2012:78). In a case study, interviews are considered as a major source of data for understanding the phenomena under study (Yin, 2009:107). Hove & Anda (2005) differentiate three types of interviews according to their degree of structure (structured, unstructured and semi-structured).

Semi-structured interviews were adopted in this study. Semi-structured interviews are a combination of structured and unstructured interviews. According to Hove and Anda (2005), semi-structured interviews combine specific questions (to bring forth the foreseen information), and open-ended questions (to elicit unexpected types of information).

For the purpose of this study, semi-structured interviews were selected to address the following research questions:

- *What are the value adding services and content considered by high schools as relevant and useful?*
- *What challenges are faced by resource-constrained public high schools regarding the lack of access to digital learning information?*

The researcher interviewed nine participants (seven teachers and two principals) in seven high schools. The semi-structured interview method allowed the high schools educators to reiterate their views about access to or lack of learning information, and secondly to identify value adding services and content regarded as relevant and useful in teaching/learning.

4.9 Data Analysis Technique

According to Yin (2004), before selecting the suitable data analysis technique for case study research, one needs to make some key assumptions. Olivier (2009:102) suggests that one possible data analysis technique may be suitable depending on the motives of the particular case study. Our case study was driven by a discovery motive. The motive is to discover the challenges faced by rural schools regarding lack of access to learning information and to discover the value adding services considered by rural schools as relevant for teaching and learning.

The method of analysis chosen for this study was a thematic data analysis technique to analyse the qualitative collected data. The thematic analysis technique is defined by Fereday and Muir-Cochrane (2006), as a search for themes that emerge as being important to the description of the phenomenon. The themes are identified through careful reading and re-reading of the data

(Fereday & Muir-Cochrane, 2006). The similarities and differences technique to identify the themes was adopted.

In this research study, data were arranged into themes related to the sub-questions, for analysis. Qualitative data analysis was done based on direct observation and semi-structured interviews. Data from the direct observation and semi-structured interviews were transcribed using Microsoft Word and interviews were recorded on a recording device to ensure that participants' responses are correctly captured.

The researcher transcribed semi-structured interviews by listening to the audio recordings and simultaneously typing everything said on the tape. Transcription of audio recordings and typing of field notes was done as soon as the data was collected. The answers were grouped into categories, themes were determined and pertinent quotes from the participants' interviews were also extracted.

4.10 Chapter Summary

In this chapter, the researcher provided detailed research design, methods and strategies which were followed in collecting data for this study. It then described how the design science research paradigm, research framework, the mapping of research questions, activities and cycles (summarised in Table 4.1) and guidelines for DSR process has been adopted for the purpose of this study.

The chapter explained how data was collected and analysed to achieve the research objectives. To complete the relevant cycle of this study, the exploratory case study was conducted in the rural public high schools located within the GTM. The chapter elaborated on the instruments used for the purpose of data gathering, aimed at finding the answers to the main research questions.

The findings of the case study are given and discussed in the following chapter.

Chapter 5 - Case Study Findings

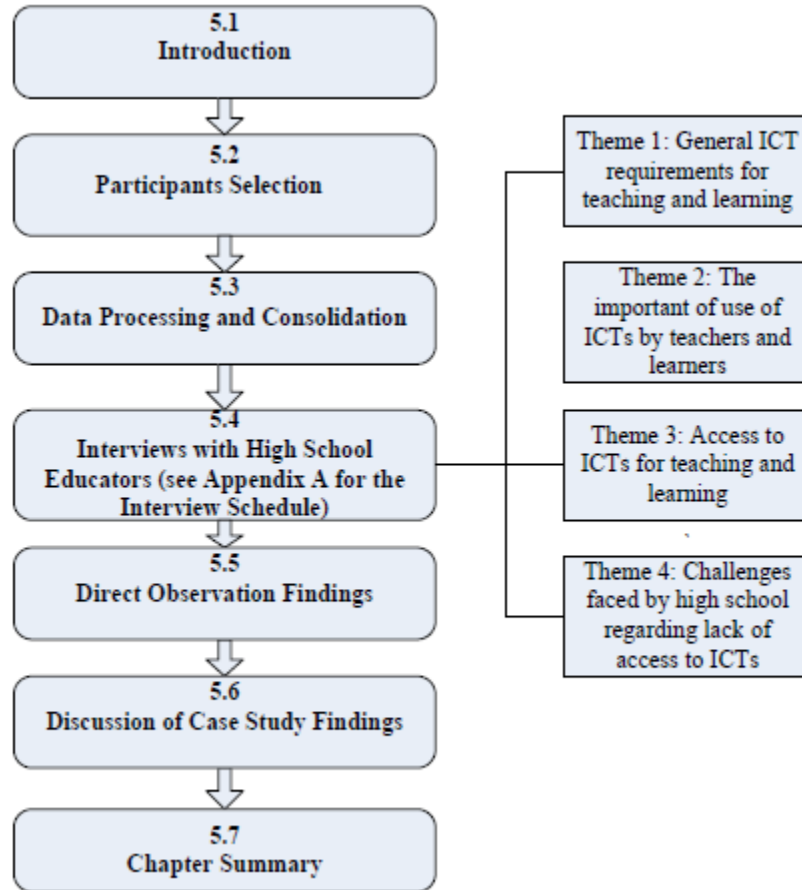

Figure 5.1: Chapter Layout

5.1 Introduction

The aim of the case study was to understand the challenges faced by resource-constrained high schools in the GTM regarding lack of access to teaching and learning material on electronics platforms. Furthermore, the case study was used to identify broadband services and digital content considered by schools as relevant and useful for teaching and learning. This chapter aims to present the case study findings of the research. The consolidated data was analysed and interpreted using data analysis techniques discussed in Chapter Four (Section 4.7). Finally, a summary and conclusions are drawn from the findings.

5.2 Participants Selection

As stated in Chapter Four (Section 4.5), the data for this case study was collected by analysing documents and using two modes of capturing the participants' experiences and views: semi-structured interviews and direct observations.

A case study can be used with other research strategies to address related research questions in different phases of a research project (Cassell & Symon, 2004:326). In our study, the exploratory case study at rural high schools of GTM was conducted to complete a relevance cycle of the Design Science Research approach. The relevance cycle connects the environment (rural public high schools) with design science activities and focuses on requirements (content and value adding services considered by high schools). Furthermore, it captures the problem to be addressed (lack of educational resources in electronic platforms) and to provide design solution artefacts (Broadband Service Delivery Model). In this study, the exploratory case study was conducted to answer the following subsidiary research questions:

- *What challenges are faced by resource-constrained public high schools regarding the lack of access to digital learning information?*
- *What are the value adding services and content considered by high schools as relevant and useful?*

As stated in the previous chapter (Section 4.5.2), the researcher visited ten high schools, but only collected data from seven high schools in different villages within the GTM between 4 and 5 September 2014. Nine participants were interviewed (two principals, two vice-principals and five teachers). Some of the principals preferred to participate with a teacher who understands ICT better. The school principals were requested to recommend a participant who could be interviewed. All participants were senior educators. For the sake of confidentiality as per the ethical clearance from the university, the schools shall be given the labels (A, B, C, D, E, F and G).

5.3 Data Processing and Consolidation

In this section, the important themes from qualitative data collected through direct observations and educators' response during interviews are identified and discussed. The interview schedule can be found in Appendix A. The themes are categorised to address the research subsidiary questions mentioned in Section 5.2.

The researcher adopted the similarities and differences techniques to identify the themes. Ryan and Bernard (2003) reported that the similarities and differences techniques involve taking pairs of expressions from the same informant and looking for their similarities and differences. The researcher summarised the raw data, marked and categorised the themes by identifying similarities and differences between respondents and field notes. Ryan and Bernard (2003) suggested coding of themes in written documents involves pawing through texts and marking them up with different coloured pens. The identified themes were clustered under the headings that directly relate to subsidiary questions.

The themes that were identified during the data gathering process were categorised as follows:

- General ICT requirements for teaching and learning
- Importance of using ICTs at public high schools
- Access to ICTs for teaching and learning
- Challenges faced by high schools regarding lack of access to ICTs

These themes are elaborated in the next section.

5.4 Interviews with High School Educators (see Appendix A for the Interview Schedule)

Themes one (1), two (2) and three (3) are addressing the research question:

- *What are the value adding services and content considered by high schools as relevant and useful?*

The emerged themes are discussed as follows:

5.4.1 Theme 1: General ICT Requirements for Teaching and Learning

Educators that participated in the interviews mentioned the following services as relevant for teaching and learning:

- Video services (e.g. YouTube, video conferences,);
- Web services (e.g. to access previous papers, Siyavula and research);
- E-mail (e.g. to communicate with other educators and for departmental correspondence);
- E-books (access to latest books in electronic formats);
- Internet connectivity; and
- Computer skills.

According to Participant three from school B, having access to these services would ease the teaching of life sciences and practical subjects. Participant five, the deputy principal from school D further mentioned that Internet connectivity would enable learners to access text books in electronic format and download previous question papers and memorandums. He also indicated that both learners and teachers should access programs, such as Siyavula⁹ (physical science and mathematics content), video content such as YouTube¹⁰, and share information through social media platforms.

“The use of the Internet and computers in teaching would make a huge impact on learners’ performance, and will prepare learners for tertiary education” said Respondent seven, the principal from school E.

Respondent six, a teacher from School E, added that e-mail facilities would ease the communication amongst the educators and other stakeholders.

⁹ For more information see: <http://www.siyavula.com/>

¹⁰ For more information see: <https://www.youtube.com/user/DBESouthAfrica>

The findings from this case study indicate that the majority of participants felt that both learners and educators should have access to Internet at schools and home. Respondent five, a deputy principal from school D highlighted that learners often depend highly on teachers to gain knowledge. Respondent five added that having access to the Internet could encourage learners to do school work at home, and it could enable them to easily adapt in this world of ever changing technology.

The findings reflect that some of the subjects need to be taught using computers with Internet connectivity in order to cover certain topics. Respondent two from school A said:

“Some of the text books reference websites for further reading and we often ask learners to use mobile phones at home to gain better understanding of a subject”

Participants one and two, both from high school A strongly believe that schools need computer labs equipped with enough computers, projectors, printers and to have access to reliable Internet.

The researcher also noted that schools need IT technical support or budget to outsource maintenance of ICTs. During the direct observations in school E, the researcher noted that only one printer out of three was functional and out of seven computers only three were in good working condition.

“Most of our computers need some repairs and the software used on these computers is outdated because schools do not have the budget to carry out maintenance” said the principal from school G.

Respondent seven from school E mentioned that all teachers need computer skills to be able to offer the Computer-Aided Design (CAD) drawing subject. He strongly believes that *“...having enough computers and reliable Internet connectivity would make it easy for teachers and learners to empower themselves”*.

5.4.2 Theme 2: The Importance of using ICTs by Teachers and Learners

The researcher discovered that in the rural public schools of the GTM, the educators find the use of ICTs very important as it enables both learners and teachers to do research about certain topics through the Internet. Respondent three from School B said:

“ICTs are important as it [they] simplify teaching and learning, minimise time and the travelling costs (e.g. question papers can be e-mailed and video conference calls can be made). It also makes it easy to make contact with the real world, for education about Ebola)”.

Educators strongly believe that ICTs will ease communication and sharing of educational information between schools in the district municipalities and within the region. Furthermore, ICTs could benefit the community as well.

“Learners will have exposure to technology and be able to assist parents with services such e-commerce.” noted the deputy principal from school D.

At school C, Participant four mentioned the importance of using video conference and e-mail facilities. She cited that time and money could be saved as teachers would not need to travel to the district municipality for meetings and workshops. Furthermore, she said Internet access is vital as it provides immediate access to up-to-date information.

Respondent 9, an educator from School G also added that:

“Today, teaching is better as compared to the olden days because ICTs make it easy to access and share the learning information”.

5.4.3 Theme 3: Access to ICTs for Teaching and Learning

The following table (Table 5.1) summarises ICTs accessibility in the high schools visited.

Table 5.1: Access to ICTs and their use for both learners and teachers

School	ICT Resources	Utilisation	Source	Challenges
A	2 printers, 2 laptops, lab with 4 personal Desktop computers (PCs)	Used mainly by teachers to type tests and for administration purposes	Donated by local mines	Computer lab is not utilised due to renovations. 2 PCs are not working
B	Computer lab with 14 PCs, DSTV and 4 printers, access to Internet (Telkom satellite)	Shared by learners and teacher for education and school administration	Donated by various companies and some were won by learners participating in different competitions	The Internet access is very slow; there is lot of theft and vandalism
C	Computer lab, 8 PCs, 1 laptop, telephone system, fax, 3 projectors and mobile internet connection	They are mainly used for teaching computer application technology (CAT), typing tests and for school admin	Donated and some were bought by Department of Basic Education (DBE)	One teacher has access to Internet using mobile modem and Network coverage is poor
D	Computer lab, scanner, 3 laptops 4 printers, mobile modem	To do scheduling and reporting, typing tests, emails and printing	Donated by Mines in the region and bought by DBE	Maintenance of devices and needs more PCs and access to internet
E	7 PCs, photocopy machine, printer	1 PC used for reporting on South African School Management System (SA-SAMS), typing tests, capturing learners' marks	PCs donated by local mines and one from DBE	No maintenance and only 3 PCs are working, no computer labs and needs funding to for repairs
F	Tablet, laptop, 3 printers and Scanner	For administration purposes and making copies	Bought by school	School has no computer labs
G	1 broken PC	For administration purposes	Supplied by DBE	School needs more PCs for learners and teachers

Accessibility to ICTs is a challenge for many of the schools in the municipality. Many of the used computers were donated by local mines and some never worked, and others are no longer in use due to lack of maintenance and technical support. Table 5.1 outlines the findings of ICT resources, utilisations, source and challenges in high schools that participated in the study. Six high schools have access to computers, scanners and printers mainly used for general school administrations. In two schools (B and C), the ICT resources are shared amongst educators and learners for teaching, school administration and learning.

Many schools are experiencing challenges in terms of maintenance and technical support of their ICT resources. During the visit to school G, the researcher noticed that the school has one computer and it was not functional during the visit. Majority of ICT resources were supplied by local mines and Department of Basic Education (DBE). The high schools with Internet connectivity are complaining about slow connectivity and reliability due to poor signal coverage.

The coverage of South African Broadcasting Corporation (SABC) Television (TV) and radio in the municipality remain a huge challenge, as the access to the public broadcaster's TV and radio is very poor in some parts of GTM. Access to radio and TV are regarded as the primary modes of information sharing and education in the rural areas (Gillwald *et al.*, 2013). In terms of telecommunication infrastructure availability, cellular network coverage in the villages surrounding GTM is also very poor. The network coverage ranged between EDGE, Third Generation and no signal in most part of the region.

“The schools and the community rely on Digital Satellite TV (DSTV) to get good television reception in the schools and homes.” Said Respondent three from school B

High schools that participated in the study have no access to fixed-line telecommunication networks connectivity. However, educators rely on mobile networks (GSM and EDGE technologies) and Telkom SA satellite technology for voice and data services. Nevertheless, the quality of both networks is very poor based on direct observations and semi-structured interviews.

With regard to the use of mobile phones, only educators are allowed to use mobile devices at schools that were part of the case study. All participants indicated that learners are not allowed to utilise mobile devices at schools, citing the following reasons:

- Learners play music during the lessons;
- Spend time on social networks;
- Take and exchange pictures amongst each other during the lesson;
- Spend time watching pornographic material;
- Steal each other's phones;
- Discriminate against learners who have no cell phones; and
- Lack of discipline.

When asked if the school allows learners to use mobile devices for educational purposes in class, participant three from school B said:

“Our learners are not allowed to bring cell phones to classrooms, because they play music, participate in the social media and it will disadvantage learners who don't have access to cell phones”

The deputy principal from school C explained that: *“We do not allow them to bring cell phones to classrooms, because they play music and watch pornographic material. However, if there is a need to use mobile phones, learners are allowed to use them for educational purposes with strict supervision”*.

Despite the banning of mobile devices' use by learners in the high schools studied, some educators believe that cell phones are a vital tool to educate the learners. However, the Department of Basic Education should introduce a policy governing the use of mobile devices in schools. Mobile device usage in schools brings along other challenges such as theft and vandalism. There have been a series of burglaries at schools in Gauteng province as people want to steal tablets donated by the DBE in the province (SA News, 2015). As the result, eighty-eight thousand (88 000) tablets were withdrawn by Gauteng provincial Government (SA News, 2015).

The principal in school F, Respondent eight argues that due to today's fast growing technology the general literacy is also changing. For instance, she is forced to ask learners to bring cell phones from time to time so that she can explain science subjects that require an Internet access.

“Yes, we do but only when they need to download certain information from the Internet. But in general no, because they capture pictures amongst themselves and share them on the social media”, said Respondent eight.

Respondent five highlighted that in Kenya some rural high schools use tablets for educating learners and based on his personal observation he noticed that learners gain more knowledge and are well disciplined. Respondent five was referring to Electronic Information for Libraries (EIFL) Public Library Innovation Programme¹¹ (EIFL-PLIP). The EIFL-PLIP program uses tablet computers to support children's education in Kenya (Kinyanjui, 2014). The goal of EIFL-PLIP is to support new and innovative library services that use technology to advance community development in Africa, Asia, Europe and Latin America.

5.4.4 Theme 4: Challenges Faced by High Schools Regarding Lack of Access to ICTs

Theme four addresses the following research question:

- *What challenges are faced by resource-constrained public high schools regarding the lack of access to digital learning information?*

The objectives are to understand the challenges faced by schools regarding lack of access to digital learning material (information and services) via the fixed or mobile networks in the GTM rural high schools.

From the interviews, it was discovered that many of the schools with access to ICTs are using them for administration and reporting purposes and they are not benefiting learners. Participant six, the principal of school E, mentioned that the school has Computer Applications Technology (CAT) as a subject, but the school does not have all the necessary equipment to implement it for teaching and learning.

¹¹ For more information see: <http://www.eifl.net/news/eifl-launches-major-library-training-initiative-kenya>

According to Respondent One, from school A, the lack of access to the Internet and poor infrastructure makes teaching and learning difficult, as the result, the performance of the learners gets affected. Respondent Five, the deputy principal from school D also finds it difficult to educate learners, and said learners in the rural areas always lose out compared to those in the urban areas due to a lack of ICTs. Respondent five stated that:

“Learners are missing critical information, such as viewing and participating on SABC educational programmes due to poor television coverage, they cannot interact with other learners from different schools due to a lack of internet access”.

School B does have Internet connectivity in the form of a satellite system (i.e. VSAT). However, the connection is not reliable and is very slow. Multiple users cannot access the Internet at the same time due to bandwidth limitations. Teachers rely on text-books for teaching and it becomes a problem as the information is outdated and limited. Respondent Nine, from school G also indicated that, the performance of learners does get affected as the teachers avoid the topics (e.g. in life science subjects) that need access to computers and the Internet.

According to the principal at school E, respondent Six, there is lack of communication between teachers in the different schools and it takes long to send messages across to the Department of Basic Education due to a lack of e-mail facilities and/or other communications infrastructure.

Due to poverty and being located in the rural areas, there is a lack of exposure to various companies in different industries as compared to schools located in the urban areas. Therefore, Internet access is the only means of getting information about various career paths for learners.

Respondent Nine added that:

“Unlike in the urban area high schools, the majority of our learners are only interested in mining because they depend on local mines for career guidance”.

Respondent Five further added that:

“In Physical Science, as the teacher you try to give various examples such as Gautrain in certain topics but because some of the learners have never been to the cities to see the trains, then it becomes difficult to educate them”.

From the two respondents (Five and Nine), it is clear that geographical location, lack of access to the Internet and poverty also remain a major challenge when it comes to providing quality of education.

The main themes, research questions, and results are summarised and tabulated in Table 5.2. The envisaged model should address the challenges mentioned by these schools including the basic requirements.

Table 5.2: Mapping of main themes, research questions and results

Main themes	Research Questions	Results
Access to ICTs for teaching and learning	What are the value adding services and content considered by high schools as relevant and useful?	Mobile modems; PCs; Tablets; Projectors; Printers; Scanners; Computer labs; Mobile & very small aperture terminal VSAT internet and Digital satellite TV (DSTV).
General ICT requirements for teaching and learning		Reliable internet connection; Video content; Digital library; e-books; e-mails & The Web.
Importance of using ICTs at public high schools		ICTs are seen as vital tool for both teaching and learning.
Challenges faced by high schools regarding lack of access to ICTs	Which challenges are faced by resource-constrained public high schools regarding the lack access to digital learning information?	Poor performance of learners; Limited resources for teaching ; Learners and teachers are excluded from digital world; Travelling costs and Information sharing among learners & other schools

5.5 Direct Observation Findings

The researcher opted to also use direct observations in the municipality and at all seven high schools visited while conducting interviews. The objectives of direct observation were to examine the existence of the telecommunication infrastructure and ICT facilities and to capture the requirements of proposed broadband service delivery model.

Figure 5.2 and Figure 5.3 illustrate the vandalised fixed line telecommunication infrastructure in the villages located in GTM.



Figure 5.2: Vandalised telecommunication infrastructures between Jane Furse and in Ga-Malekane village.



Figure 5.3: Vandalised telecommunication infrastructures in Ga-Malekane village.

Out of seven schools that participated in the interviews between 4 and 5 September 2014, the following was observed:

- All schools and surrounding villages have access to electricity.
- The area is mountainous and the quality of cellular networks (voice and data) is very poor in some areas, particularly in school D and E.
- Due to the poor quality of TV signals, residents cannot access some of SABC TV channels.
- Making voice calls was possible on the MTN network, and data connection was very poor in many parts of the area.
- Both MTN and Vodacom coverage is intermittent in some villages located in the GTM.
- The area has no fixed-line copper telecommunication infrastructure due to vandalism.
- Many of Telkom SA's cables were cut and some were hanging on the poles.
- Many business and government departments depend on Telkom SA satellite and mobile networks for telephone services
- High schools F and G have no working computers and educators are using their personal laptops.
- Three schools are equipped with computer labs used by learners and educators.
- One school has satellite Internet connectivity in their labs and staff rooms.
- Five schools have access to computers used for South African School Management System (SA-SAMS) for reporting and administration.
- The computers are mainly used by teachers for school administrations such as typing tests and capturing learners' marks.
- Many computers were donated by local mines and the majority of them were not working and maintained.
- All schools have access to functional printers, scanners and photocopy machines.
- Four educators use their personal laptops, tablets and cellular modems to connect to the Internet.

During the interviews, the researcher observed that educators understand the importance of ICTs; however, accessibility to Internet connectivity is seen as a major challenge in all schools that participated in the research.

5.6 Discussion of Case Study Findings

The findings from the case study confirm that rural schools in the GTM are experiencing challenges of lack of access to digital learning material and broadband services. From the interviews, it was noted that lack of access to the Internet and poor infrastructure makes teaching and learning difficult. The case study findings support the statement of Dlodlo (2007); Section 27 (2014) and Khumalo *et al.* (2015) who states that the lack of ICT infrastructure, shortage of text books and limited information in the textbooks and access to the computers, let alone access to the Internet, impact negatively on the teaching of science subjects in the rural public schools.

From theme Four, it was identified that lack of ICT infrastructure does negatively affect learners' performance. Many educators rely on traditional text books for teaching life science and computer skills subjects. This becomes a problem as they have limitations and information is outdated (Ford *et al.*, 2014). Lack of broadband connectivity required by public institutions such as schools impacted negatively on the country's development and global competitiveness (Khan, 2015).

From theme Two, it was noted that having access to learning material in electronic platforms could afford educators and learners the opportunity to interact with the outside world, and also could benefit the community as the whole. However, the Department of Basic Education (DBE) should introduce a policy governing the use of mobile devices in schools. Literature suggest that use of ICT brings some challenges such as learners spending time focusing on the websites containing pornographic material, which could require teacher to spend much time trying to control students from using websites unrelated to the learning content, instead of focusing on teaching (Mathevula & Uwizeyimana, 2014).

The findings indicate that schools require reliable Internet connectivity to access services such as video, web, e-mail, digital library and e-books for teaching and learning practical and life science

subjects. From Mkhomazi and Iyamu's (2011), Mathevula and Uwizeyimana (2014) and Khumalo *et al.* (2015) findings, the ICT adoption could enable the educators to obtain real-time material and use programs such as video conferencing to interact with outside world.

From the observations, it was also noted that schools are experiencing difficulties in accessing digital educational programs and learning materials due to the poor quality of telecommunication networks and limited computers. The data connection via cellular networks is challenging in some parts of the area, which makes it difficult to access data rich content. These research findings confirm the statement by Sibanda *et al.* (2008), Huang *et al.* (2012) and Agarwal and De (2016), who argue that the geographical landscape in most of the rural areas brings challenges to deploy telecommunication networks, because there are valleys, swamps, and mountainous terrain. From the case study findings, the researcher noted that the geographical landscape in the GTM does affect access to television and radio services as well.

From the GTM case study findings, the researcher understands the challenges faced by under-resourced public schools (environment) and Chapter Six discusses the proposed broadband service delivery model (artefact) to address some of the identified problems. The model forms part of the main contribution from this research study.

5.7 Chapter Summary

In this chapter, the researcher explained how the themes were formulated to address research sub-questions. The researcher presented, analysed and discussed data collected mainly from semi-structured interviews from educators from rural high schools located in the GTM. The results from direct observations were also discussed in this chapter. Data presentation, analysis and discussion were done in line with the subsidiary research questions that guided the study.

Chapter 6- Proposed Service Delivery Conceptual Model

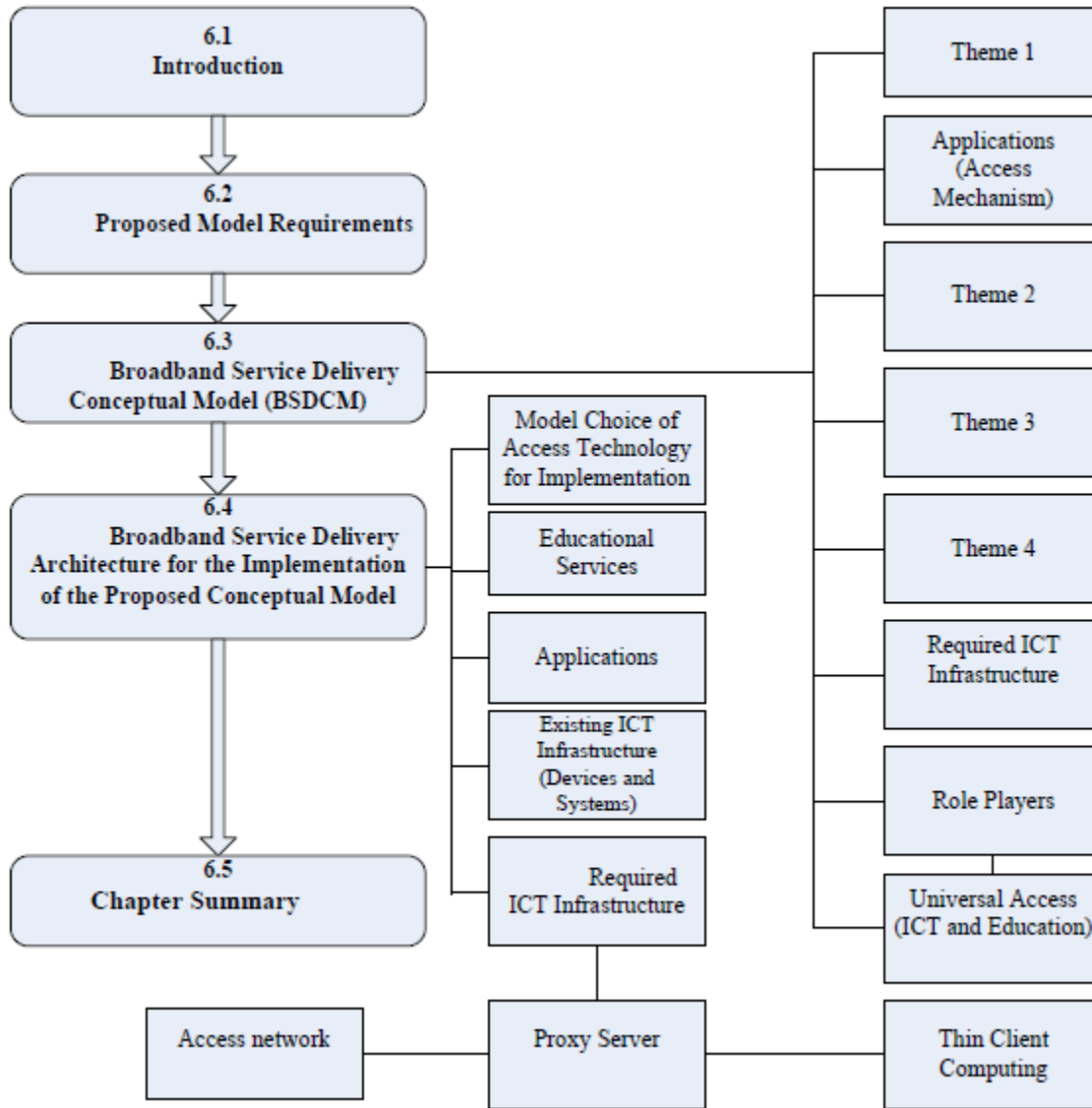

Figure 6.1: Chapter 6 Layout

6.1 Introduction

This chapter forms part of the seven guidelines for Design Science Research process discussed in Chapter Four (see Section 4.4). The chapter marks the beginning of design and development phase (design cycle) in the design science research cycles (see Table 4.1).

Based on an identified set of requirements highlighted in Chapter Two (see sub-sections 2.2.1-sub-section 2.2.2) and Chapter Five (see sub-sections 5.4.1 and sub-section 5.4.4), this chapter investigates, designs and develops the broadband service delivery conceptual model that could address the challenges discussed in the literature review (found in Chapters Two and Three) and Greater Tubatse Municipality (GTM) case study findings (found in Chapter Five). In Section 6.3, the broadband service delivery conceptual model that supports the proposed broadband service delivery technical architecture for implementation (see Section 6.4) suitable for resource-constrained environments is presented. Furthermore, the proposed model addresses some of the limitations identified in Section 3.5 of Chapter Three. Finally, Section 6.5 summarises and concludes the chapter.

This chapter addresses the following subsidiary research question:

- *How to design an appropriate service delivery conceptual model for seamlessly delivering broadband services (e.g. digital learning information) to resource-constrained public high schools?*

6.2 Proposed Model Requirements

This section presents a set of requirements for the proposed broadband service delivery model which were developed from the themes derived from the GTM case study as discussed in Chapter Five (see sub-sections 5.4.1 and sub-section 5.4.2). In addition to the requirements developed from the case study, the basic requirements of Mobile Service Delivery Platforms (MSDPs) outlined in Chapter Three (see Section 3.3), and comparison of MSDPs against the requirements for general Service Delivery Platforms (SDP) relevant in the resource-constrained environments summarised in Table 3.2 are also taken into consideration. In Chapter Five (see Section 5.3), the following themes were identified:

- Theme 1: General ICT requirements for teaching and learning
- Theme 2: Importance of using ICTs at public high schools
- Theme 3: Access to ICTs for teaching and learning

- Theme 4: Challenges faced by high schools regarding lack of access to ICTs

Themes 1, 2 and 3 are identified as the value adding services and digital content considered by resource-constrained high schools in the GTM as relevant and useful. Theme 4 discussed the challenges faced by resource-constrained high schools in the GTM regarding the lack of access to digital learning information. In Table 6.1, the requirements from the case study and basic requirements of MSDPs and general requirements for Information Communication Technology for Education (ICT4ED) are summarised.

Table 6.1: Requirements developed from case study and MSDP

Requirements developed from case study	Requirements of MSDP	Summarised general requirements for ICT4ED
<ul style="list-style-type: none"> • Theme 1: Reliable internet connection; Video content; Digital library; e-books; e-mails and the Web. 	<ul style="list-style-type: none"> • Minimal total life cycle cost • Ease of Use and Accessibility 	<ul style="list-style-type: none"> • Educational services
<ul style="list-style-type: none"> • Theme 2: ICTs are seen as vital tools for both teaching and learning. 	<ul style="list-style-type: none"> • Synergies and Interoperability • Bearer and Device Agnostic 	<ul style="list-style-type: none"> • Important of using ICT
<ul style="list-style-type: none"> • Theme 3: Mobile modems; PCs; Tablets; Projectors; Printers; Scanners; Computer labs; Mobile & Very Small Aperture Terminal (VSAT) Internet and Digital satellite TV (DSTV). 	<ul style="list-style-type: none"> • Re-usable Modules • Flexibility And Extendibility • Leverage Available Skills • Scalability 	<ul style="list-style-type: none"> • Required infrastructure
<ul style="list-style-type: none"> • Theme 4: Poor performance of learners; Limited resources for teaching; Learners and teachers are excluded from the digital world; Travelling costs and Information sharing within learners & other schools 	<ul style="list-style-type: none"> • Availability (from Rural context) • Performance 	<ul style="list-style-type: none"> • Educational challenges

The requirements from theme 1 and theme 3 are supported by literature findings (see sub-section 2.2.2), which suggest that computer technologies such as CD-ROMs, web browsers, e-mail services, MP3 players, audio-visual facilities, skype, Internet connectivity, Interactive teaching programs (ITP) and power-point presentations or video recordings could promote interactive teaching and learning (Bester & Brand, 2013; Condie & Munro, 2007; Mkhomazi & Iyamu 2011). Ford *et al.* (2014) also added that the use of tablets and smartphones, which make it possible to access the digital content such as electronic text books, has become popular in both developing and developed countries. Theme 2 emphasises the need of access to ICTs in the classrooms. From the literature review (see sub-section 2.2.1), there is evidence that learners who use ICTs for learning could have better success in Science and Mathematics subjects as compared to those who do not have ICTs in the classroom (Mikre, 2011; Chigona *et al.*, 2014).

In Section 3.5 of this study, there is evidence that most MSDPs do not meet all the basic requirements of SDP, particularly in the resource-constrained environments. Some of the limitations of MSDPs include:

- Complexity;
- Not suitable for rural deployment;
- Not being accessible and easy to use; and
- Significant bandwidth requirements.

As discussed in Section 3.5, the majority of the platforms evaluated are very complex and not easy to use for non-skilled end-users, they required highly skilled programmers. In addition, implementation of existing MSDPs in developing countries such as South Africa remains a challenge, majority of platforms are based on Next Generation Network (NGN), which requires significant bandwidth.

The lack of appropriate SDPs for resource-constrained environments is the motivation of this study. The proposed broadband service delivery conceptual model seeks to address the challenges highlighted in theme 4 and sub-section 2.2.3, taking into consideration the limitations of other MSDPs identified in Section 3.5 of Chapter Three.

6.3 Broadband Service Delivery Conceptual Model (BSDCM)

Conceptual modelling is defined by Liu *et al.* (2012) as “the abstraction of a model from a real or proposed system, which includes specifications of reality”. The conceptual model provides a means of communication and understanding of a specific domain between stakeholders of the system and the developers or domain aspect of the system (Gemino & Wand, 2004). In the view of Pilkington and Pretorius (2015), conceptual modeling can also be seen as “identifying, analysing and describing the essential concepts and constraints of a domain with the help of a (diagrammatic) modeling language”. Conceptual modeling language comprises a set of constructs, which are often represented by graphical symbols to create a representation (Gemino & Wand, 2004).

In the communication systems domain, conceptual modeling is an evolutionary process in which new concepts enhance and complement earlier communication models (Fedaghi *et al.*, 2009). For example, in the study conducted by Christian and Hanrahan (2007), the concepts and architecture of standardised Intelligent Networks (IN) that contributes to new and older telco standards, was re-used to define a generic SDP architecture.

To identify various components that provide the guidelines and support a conceptual model suitable for resource-constrained environments discussed in Section 6.4.1, a broadband service delivery conceptual model depicted in Figure 6.2 was designed. These components formed part of a technical architecture for the implementation of the proposed BSDCM presented in Figure 6.3.

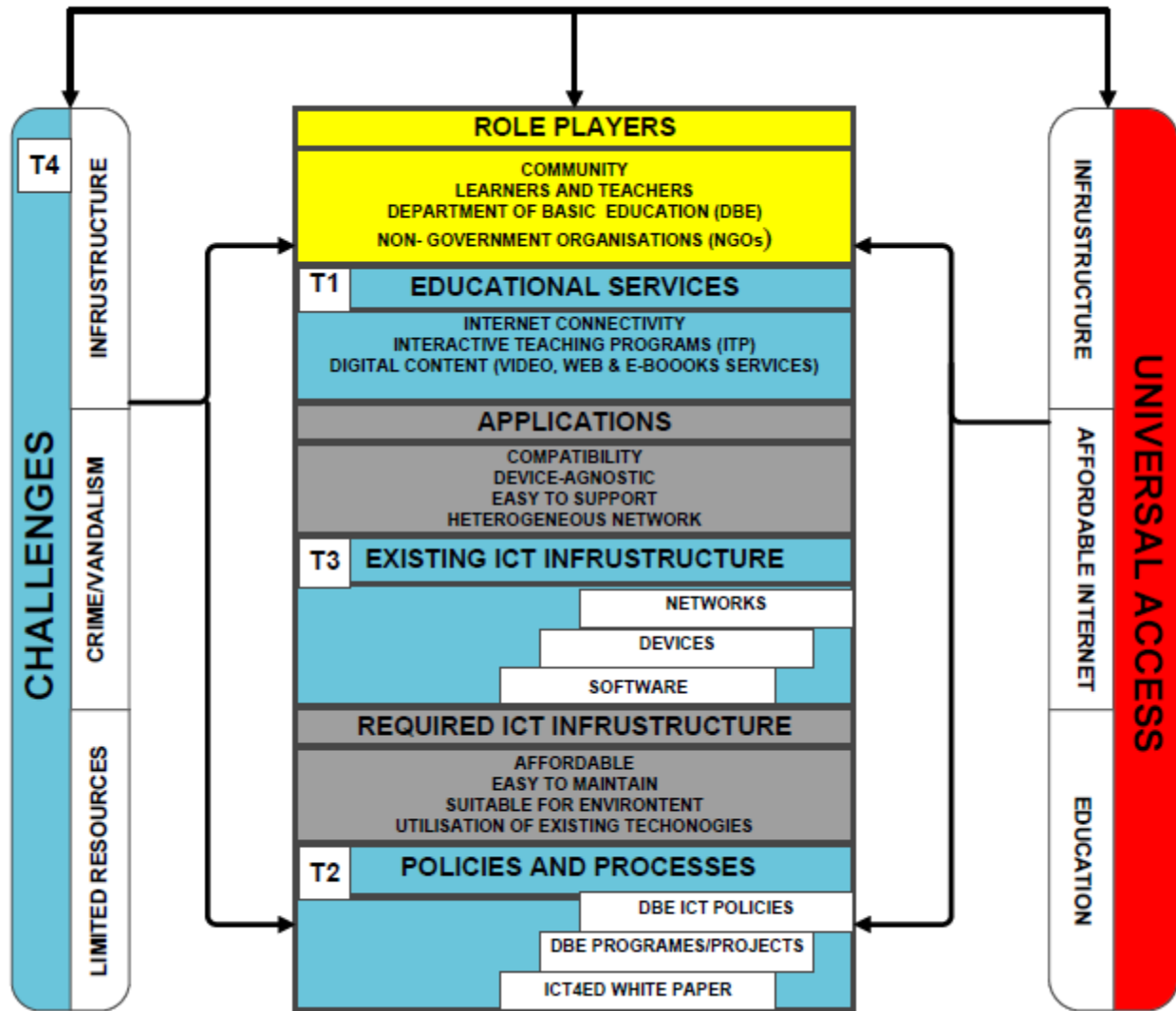

Figure 6.2: Broadband Service Delivery Conceptual Model (BSDCM)

This conceptual model shows the relationship between the identified themes (T1 to T4) detailed in Chapter Five (Section 5.4) and the role-players in Information Communication Technology for Education (ICT4ED). The conceptual model also aims to support role players at Government and Non-Government sectors to make decisions regarding the implementation of ICTs as a tool for teaching and learning in resource-constrained schools.

With any ICT intervention, it is very important to understand:

- The requirements of role players (learners and teachers);
- What are the ICT challenges? (all role players);
- Who should benefit? (community, schools, and so forth);

- What are other ICT4ED interventions? (NGOs, DBE, and so forth); and
- What are the policies and the processes are in place? (Policy makers, DBE, and so forth).

The BSDCM is made up of seven components, the text in brackets refers to the layers in the above broadband service delivery conceptual model and are discussed as follows:

6.3.1 Theme 1 (T1): General ICT Requirements for Teaching and Learning (Educational Services)

Theme 1 summarises requirements for teaching and learning using digital learning information. This component connects both Theme 2 and Theme 3 components. This component informs Government and Non-Government Organisations stakeholders about the nature of value adding services and content considered by high schools as relevant and useful.

It is very important to know which educational content and services are required by educators to facilitate teaching and learning in their environments before designing the solution. The requirements should be in line with Department of Basic Education’s (DBE) ICT policies and processes, programs such as Accelerated Schools Infrastructure Delivery Initiative (ASIDI) and the DBE current curriculum.

6.3.2 Applications (Access Mechanism)

The applications component refers to the cross-platform applications such as web and mobile applications that could be used for delivering various educational services and content in different computing platforms. This component focuses on the following specifications:

- **Device Agnostic:** Applications should be compatible with multiple operating systems and work on different types of end-user devices such as mobile phones, tablets, laptops, and so forth. The digital services should be accessible from any device using different access methods.
- **Bearer Agnostic:** The component also focuses on network bearers such as bandwidth limitations, the applications should be able to adjust bandwidth usage to fit within any network scenario. In addition, the applications should meet the requirements that lead to

the efficient (re-) usage of available resources such as networks and various technologies in any environment.

- **Multi-Vendor Support:** The applications should not be vendor specific, but rather be executed in environment that consists of different manufacturers' hardware for heterogeneous network deployment.

6.3.3 Theme 2 (T2): Importance of Using ICTs at Public High Schools (Policies and Processes)

As highlighted in the literature review (sub-section 2.2.1) and, supported by case study findings (sub-section 5.4.2), the adoption of ICTs in the classrooms is very important. ICTs and particularly Internet connectivity can provide immediate access to up to date information and also improve collaboration between learners and educators and amongst educators themselves.

The policy and process component (Theme 2) is the foundation of the ICT4ED. In conjunction with the role players' component, the component refers to the DBE's ICTs in Education policies such as Guidelines for Teacher Training and Professional Development, Operation Phakisa ICT in Education Lab program and the White Paper on e-education. Additional policies are still required such as mobile device usage policies in public schools. As discussed in Chapter Two (sub-section 2.2.1), these policies and processes support and promote the growth of ICTs in schools. The proposed BSDCM is intended to fit with the DBE ICT policies, align with recent initiatives and also contribute to the DBE's programs.

6.3.4 Theme 3 (T3): Access to ICTs for Teaching and Learning (Existing ICT Infrastructure)

The current state of ICTs infrastructure in the resource-constrained public schools component form part of the key requirement of the proposed broadband service delivery model. It is important that this requirement be taken into consideration when proposing a technical architecture that supports the access to digital content for high schools in the resource-constrained environment. This component forms part of Theme 3, which refers to existing ICTs that the schools have access to. The ICTs include end-user devices, type of networks, access technologies, computer laboratories and the software being used. The same ICTs infrastructure

should be re-used to build a cost effective, user friendly and sustainable digital educational content delivery model for resource-constrained environments.

6.3.5 Theme 4 (T4): Challenges Faced by High Schools Regarding Lack of Access to ICTs (Challenges)

This component (Theme 4) links the role players, T1 to T3 and the new infrastructure components. The main objective of this component is to outline the challenges faced by resource-constrained high schools regarding lack of access to ICTs. The challenges include: limited educational resources and services (discussed in sub-sections 2.2.3 and sub-section 5.4.4), which are very important. The lack of ICT infrastructure may also lead to poor performance of both learners and teachers, exclusion from the digital world and lack of collaboration with other role players. Theft and vandalism is also one of the challenges that could affect the deployment of new ICT infrastructure negatively. The proposed BSDCM takes these challenges into consideration.

6.3.6 Required ICT Infrastructure

The aim of this component is to propose new ICT infrastructures, which could address some of the short comings of the existing ICT infrastructure highlighted in Theme 4. The infrastructures could include new hardware devices (modems, mobile phones, and so forth), computer laboratories and the networks. It is important that the new infrastructure utilises existing technologies outlined in Theme 3, be able to deliver digital content and services highlighted in Theme 1, be easy to deploy, affordable, easy to maintain and support, be sustainable and also suitable for the environment.

6.3.7 Role Players

This component is the cornerstone of the whole BSDCM. It is important because without role players' involvement any ICT intervention will not succeed. The role players from the ICT4ED context refer to the local community, learners and teachers, policy makers, the Department of Basic Education (DBE) and Non-Government Organisations (NGOs). All these role players could benefit from ICTs, support ICT adoption and also make a contribution towards ICTs implementation in resource-constrained environments.

6.3.8 Universal Access (ICT and Education)

Universal access to ICTs and education refers to providing all communities with affordable access to ICTs and equal education irrespective of the environment (Ebner et al., 2008). In our BSDCM, the component refers to affordable Internet, access to education for all and availability of ICT infrastructure to deliver education content and services in the classrooms.

As highlighted in Chapter Two (sub-section 2.2.2), having access to mobile devices, personal computers (PC), applications such as social networking platforms and freely available Instant Messaging (IM) applications could potentially be used for teaching and learning platforms.

This section focused on BSDCM, paying attention to themes detailed in Section 5.4 and the role players within Information Communication Technology for Education (ICT4ED) context. The model is made up of eight main components, which includes four main themes (T1-T4), applications component, required ICT infrastructure, role players and universal access (ICT and education). As highlighted in Section 3.5 the existing MSDPs do not meet all the minimum SDP requirements such as availability from resource-constrained environment context, complexity, accessibility and ease to use and significant bandwidth requirements. The proposed BSDCM seeks to address some of the limitations of existing MSDPs. Furthermore, it addresses challenges faced by resource-constrained public schools regarding lack of access to educational content in electronic format by re-using the existing ICT infrastructure.

In the next section, the broadband service delivery technical architecture for the implementation of the proposed conceptual model is presented.

6.4 Broadband Service Delivery Architecture for the Implementation of the BSDCM

According to Hevner (2007), the design cycle activities of Design Science Research include the construction of an artefact, its evaluation against the requirements, and feedback to refine the design further. The aim of this section is to present an alternative technical architecture for the implementation of a proposed broadband service delivery conceptual model suitable for resource-constrained public schools. In this section, we focus on the following technical

components derived from the broadband service delivery conceptual model (see Figure 6.2) as follows:

- *Educational Services;*
- *Applications;*
- *Existing ICT Infrastructure; and*
- *Required ICT Infrastructure.*

However, as indicated in Chapter One (Section 1.8), this study focuses on access networks; therefore the Internet Service Provider’s (ISP) backbone network in this architecture is beyond the scope of this study.

In Figure 6.3, we present the technical architecture for the implementation of proposed BSDCM. The elements of architecture are discussed further in sub-sections 6.4.1 to sub-section 6.4.5.

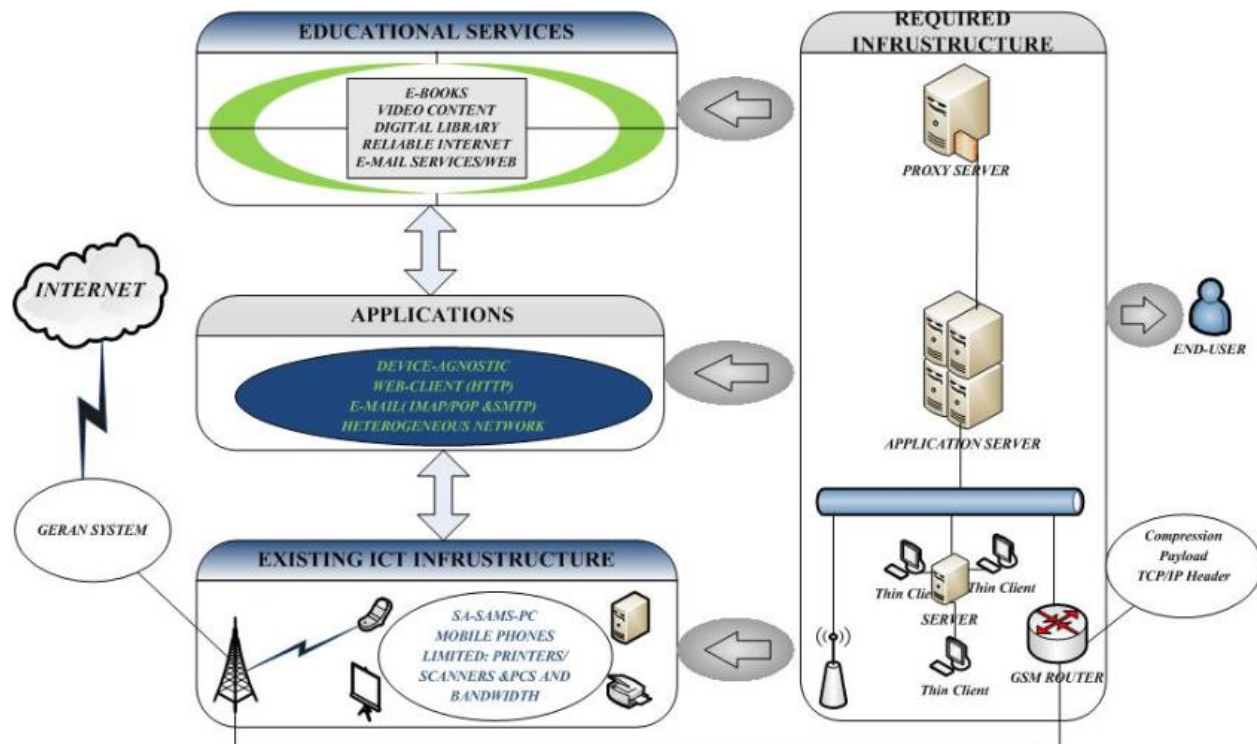

Figure 6.3: Architecture for the Implementation of the Proposed Broadband Service Delivery Conceptual Model.

The evaluation of a proposed model against the general requirements of existing broadband service delivery platforms and set of requirements developed from the case study (see Figure 6.2) is discussed in Chapter Seven.

6.4.1 Choice of Access Technology for Implementation

The discussion in this sub-section focuses on the choice of mobile access technologies, which form part of the existing ICT infrastructure component of presented BSDCM (see Figure 6.2). This focus is mainly on the state of mobile network access technologies in the GTM case study (see Figure 2.2).

The choice of appropriate mobile access technologies for implementation was guided by the conceptual model presented by Mekuria (2011) (see Figure 2.3), which is based on the quality of service (QoS), energy efficiency, cost, service usability, sustainability, optimisation, rural context and best fit parameters. In addition, one of the requirements of Service Delivery Platforms (SDP) as discussed in Section 3.3 is to re-use available network technological capabilities to aid service creation and development and to ensure equitable access to digital content and service. Furthermore, the choice of technology is also motivated by the existing infrastructure component (Theme 3), which promotes the re-use of existing ICTs infrastructure to build cost effective, user friendly and sustainable digital educational content delivery models for resource-constrained environments.

The mobile access technologies are appropriate for resource-constrained environments as many developing countries such as South Africa, have been able to leverage mobile technologies to overcome fixed line infrastructure barriers and provide connectivity to previously unconnected areas (see sub-section 2.3.2).

In the case of proposed technical architecture for the implementation of the proposed BSDCM (Figure 6.3), the network abstraction requirement is achieved by re-using the Global System for Mobile communication (GSM) and Enhanced Data rates for GSM Evolution (EDGE) Radio Access Network (GERAN) available in the GTM. GERAN technology provides high schools users access to heterogeneous network resources and capabilities. The decision to adopt GERAN

technology as the access infrastructure that the resource-constrained public schools could connect through is supported by popularity, high availability, fast growing and the easy to access capability of GERAN technology as expressed by Axelsson *et al.* (2006), Louw & Dörflinger (2010) and DOC (2013). In addition, the case study findings in Chapter Five have also shown that there is GSM and EDGE coverage to deliver voice and data services in most parts of the GTM (see Sub-section 5.4.3).

Many studies have shown that GERAN technology is readily available in most parts of South African resource-constrained environments (Louw & Dörflinger, 2010; DOC, 2013). The statement by Axelsson *et al.* (2006) also suggests that the legacy of GSM and EDGE technologies are widely used in many countries (see GSM/EDGE global footprint Figure 6.4)



Figure 6.4: GSM/EDGE Global Footprint (Adapted from Axelsson *et al.*, 2006)

According to Müller *et al.* (2012), the evolution of GERAN technology enables mobile operators to use existing GSM frequency bands to provide UMTS (3G) broadband services, such as e-mail and Web browsing, video conferencing and voice over IP (VoIP). However, from the GTM case study findings there is evidence that there is coverage of GSM to carry voice traffic, but data connectivity in the form of 3G networks remains a big challenge in some parts of the GTM (see Section 5.5). Moreover, the delivery of data rich traffic in GSM technology (2G) is a challenge, as the data transmission on GSM system is usually over voice channel at a speed ranging from 9.6 kbps to 14.4 kbps (Wandre, 2000). With the introduction of EDGE technology, the delivery of digital content could be achieved, albeit at slow speeds. As discussed in Section

2.3.2.1, the EDGE technology gives GSM systems the capacity to handle services for 3G at the speeds of up to 472kbps.

This sub-section outlined the choice of appropriate access technology used to implement the proposed BSDCM from resource-constrained public schools context. GERAN technology was chosen because it is available in the GTM and is a fast growing technology as opposed to other technologies. The choice of technology forms part of the existing ICT infrastructure component of the presented broadband service delivery conceptual model. Furthermore, the choice of technology is motivated by requirements of general SDP, which encourage the re-use available network technological capabilities to deliver content and services.

The next sub-section discusses the educational services considered by schools as relevant for educational purposes.

6.4.2 Educational Services

In Figure 6.3, the educational services element refers to digital educational services and content considered as relevant to promote interactive teaching and learning in electronic platforms. This is a very critical element of the architecture as it forms part of requirement of a broadband service delivery conceptual model from an educational perspective. As indicated in Chapter Two (see sub-section 2.2.2) and Chapter Five (see sub-section 5.4.1), the services which could aid the educators and learners to obtain real-time digital material include:

- Video services;
- Interactive teaching programs (ITP);
- Educational gaming;
- Instant Messaging (IM);
- Web services (e.g. to access previous papers and research);
- E-mail (e.g. communicate with other educators and department correspondence);
- E-books (access to latest books in electronic format);
- Reliable Internet connectivity; and
- Computer skills.

In the case of GTM, reliable Internet connectivity is seen as the basic need to enable access to various educational services in the classrooms. To gain better understanding of certain topics discussed in the classroom and to adapt in this world of ever changing technology, the majority of research participants felt that both learners and educators should have access to the Internet at school and at home. Furthermore, educators strongly believe that having access to ICT services such as e-mail, video content, interactive boards and e-books will not only aid teaching and learning, but could also save schools time and money as teachers will not always travel to the district municipality for meetings and workshops.

These requirements are in line with Department of Basic Education's (DBE) policies and goals discussed in Chapter Two. In sub-section 2.2.1, we discussed some of digital content providers who are currently supporting teaching and learning via technology-led innovations in South African schools including Google in Education, Intel Teach, SchoolNet and Microsoft Partner in Learning. In addition, the Department of Basic Education (DBE) third party content providers such as Second Chance Matric Programme¹², Thutong Portal¹³ and social media platforms could also take advantage of broadband access to deliver digital content and services to public schools.

This sub-section discussed digital content and services considered by educators as relevant for teaching and learning. In the next sub-section, we discuss the mechanisms of accessing various services listed earlier in this sub-section.

6.4.3 Applications

The main function of the applications element in the implementation architecture is to ease access to electronic services from content providers highlighted in sub-section 6.4.2 to the users (learners or educators) through devices that they have access to. As discussed in sub-section 6.3.2, the service delivery applications component should be compatible with devices that

¹² Second chance matric programme aims to offer learners who failed to meet the requirements of the National Senior Certificate a second chance to obtain matric. More information about the program is available from: <http://www.education.gov.za/Programmes/SecondChanceProgramme/tabid/932/Default.aspx>

¹³ Thutong Portal deliver information, curriculum, and support materials to the South African schooling community, More information available from: <http://www.thutong.doe.gov.za/>

schools have access to and also meet the requirements that lead to efficient (re-) usage of available resources such as networks and various access technologies in any environment.

In the proposed broadband service delivery model for implementation architecture (Figure 6.3), the client-site traditional Web application using the Hypertext Transfer Protocol (HTTP) access mechanism is proposed to provide access to web-based electronic mail (e-mail), Instant messaging (IM), electronic books, video content and web resource (World Wide Web). Recent studies have shown that the Web application domain is one of the fastest growing domains, and today is used in almost every facet of our lives to deliver various resources such as images, video and plain text (Maras *et al.*, 2013; Liu *et al.*, 2015). The client-site Web applications act as a user interface (UI) by utilising standard browsers to access content either on mobile device platforms or via PC.

Web applications are device-agnostic as they can operate across various types of devices, including desktop computers, laptops, and mobile devices such as tablets and smart phones identified in the resource-constrained high schools. Although findings from the GTM case study highlighted that the majority of public high schools do not allow learners to use mobile phones in the classrooms, educators still allow learners to use mobile devices to access educational content through web applications with strict supervision (see sub-section 5.4.3). Furthermore, in some instances, educators indicated that they would request learners to use mobile devices at home to research information about certain educational topics.

This sub-section described Web applications as the potential mechanism to access the educational services listed in sub-section 6.4.2. The next sub-section discusses the existing ICT infrastructure that the public schools have access to.

6.4.4 Existing ICT Infrastructure (Devices and Systems)

Following the proposed delivery mechanism of educational services and content discussed in the previous sub-section, this sub-section discusses the existing ICT infrastructure. Specifically, this sub-section discusses devices that the GTM schools have access to and status of current systems and network connectivity.

During the observations and interviews in the GTM, it was discovered that the quality of telecommunication networks is very poor in most parts of the areas that formed part of the case study. There is no fixed line copper telecommunication infrastructure due to vandalism (see Figure 5.2 and Figure 5.3). The majority of businesses and government departments depend on Very Small Aperture Terminal (VSAT) systems for voice and data services. The quality of voice call through cellular networks appears to be good in most parts of the municipality. However, data connection via costly and limited bandwidth from VSAT technology and poor third generation (3G) coverage is very challenging in some parts of the municipality, which makes it difficult to access real-time services and data rich content, such as video recordings presentations. Both Vodacom and MTN cellular coverage is very intermittent in most villages located in the GTM.

In terms of end-user devices, the results from the GTM case study have shown that educators in many high schools that participated in this research study have access to ICTs. From Theme 3, it was highlighted that the majority of high schools have access to limited devices such as personal computers (PCs), GSM modems, and mobile devices (smart phones and tablets), scanners and printers. However, it must be noted that the majority of PCs, printers and scanners were donated by local mines and are not maintained due to costs. The research findings also show that four of the seven high schools that participated in the study are equipped with computer laboratories, and only one out of four high schools have computer laboratories with VSAT internet access and limited bandwidth is shared amongst educators and learners.

At least six of the high schools are equipped with PCs supplied by the DBE for the South African School Administration Management System (SA-SAMS) application. As discussed in Chapter Two (see sub-section 2.2.2), the SA-SAMS is mainly used by South African public schools for school curriculum administration, learners and staff management and governance (DBE, 2013). Due to lack of connectivity to resource-constrained high schools, the SA-SAMS is not linked to other systems at the DBE. As highlighted in Muriithi & Masinde's (2016) findings, public schools in the resource-constrained environments are often forced to abandon SA-SAMS because of unreliable systems, which makes it difficult to submit data to the DBE on time; this also has challenges of limited access to few users, technical support and training.

This sub-section presented the current ICT infrastructure. The sub-section focused particularly on access network status, devices and systems being used in the public high schools. The next sub-section proposes the new ICT infrastructure that could use existing networks and devices to deliver educational services.

6.4.5 Required ICT Infrastructure

The majority of multimedia services such as video streaming, and educational gaming highlighted in sub-section 6.4.2 are data rich. Handling multimedia data requires more resources such as high performance computing, more bandwidth and optimisation in transmission of data. In Section 2.3, it was highlighted that access to bandwidth and computers still remains a challenge in South Africa, particularly in resource-constrained environments. To address these challenges, this sub-section briefly proposes required infrastructure and mechanisms to provide access to educational services in resource-constrained public schools.

From the guidelines outlined in the BSDCM in sub-section 6.3.6, it should be noted that utilisation of existing technologies, affordability, maintenance and support will be taken into consideration when proposing the required infrastructure.

The cost of required infrastructure is currently unknown. However, in the proposed broadband service delivery architecture, the cost is reduced by re-using current access network technologies instead of deploying a new last mile network infrastructure, which is still a challenge in resource-constrained environments. Furthermore, the adoption of compression and caching proxy techniques (see sub-section 6.4.5.2) and Thin Client computation (see sub-section 6.4.5.3) could also reduce the costs. The only expected capital costs will be in the purchase of routers and servers. At this stage, the cost of new equipment might be higher, but in the long run the benefits could be higher than the cost of required infrastructure.

6.4.5.1 Access Network

In the implementation architecture presented in Section 6.4 (Figure 6.3), the main function of GERAN is to interface the radio signal to Customer Premises Equipment (CPE) such as mobile devices, Wi-Fi access points and GSM/GPRS/EDGE routers.

To address the limited bandwidth challenges highlighted in sub-section 6.4.4, the researcher proposes a router equipped with GSM/GPRS/EDGE modules for optimisation and Internet Protocol (IP) packet compression of Wide Area Network (WAN) data traffic. The Transmission Control Protocol (TCP) over the Internet Protocol (IP) (TCP/IP) header compression scheme is widely used to improve the performance of low-speed links.

In Chapter Seven (evaluation), the details of adopted of compression techniques are demonstrated in the form of simulations.

6.4.5.2 Proxy Server

In Chapter Three (Table 3.2), the comparison of MSDPs against the minimum requirements of general SDP is outlined. Drawing from Table 3.2, it must be noted that the majority of the platforms evaluated are very complex and not easy to use for non-skilled end users. Furthermore, they are based on Internet Protocol (IP) Multimedia Subsystem (IMS) access networks to deliver digital content and multimedia services. Through the literature reviews and case study conducted in the GTM, accessing multimedia services over 3G technologies remains a challenge in the resource-constrained environments. This sub-section addresses some of the challenges relating to limited bandwidth and technical support faced by resource-constrained high schools.

To reduce web access latency and network administration challenges in the high school's Local Area Network (LAN), we would introduce compression and caching proxy server. Proxy servers have been widely used for web content and video streaming to reduce the response time, network traffic and server resources (Ma & Du, 2002; Xiao *et al.* 2010). Data compression and decompression techniques have been applied for addressing networking latency challenges, saving storage space, saving device power consumption and reducing transmission cost in mobile networks (Xiao *et al.*, 2010).

Data compression as explained by Dhar (1990), involves using special algorithms to reduce time needed to transmit information across the network without losing the information. According to Wang and Manner (2009), there are two types of data compression algorithm techniques,

namely, lossy and lossless compressions. The lossy compression algorithm improves a better compression ratio by introducing differences to reconstructed data and original data is not exactly restored after decompression (Wang & Manner, 2009). The lossless data compression algorithm allows the original data to be reconstructed from the compressed data (Brittan, 2008).

In this study, the lossless data compression algorithm could be adopted for the server environment. The decision to choose the lossless data compression algorithm to compress broadband services is supported by the fact that it has many advantages on mobile devices. The advantages of the lossless data compression algorithm are listed by Brittan (2008) as follows:

- Can reduce the network bandwidth required for data exchange;
- Can reduce the disk space required for storage; and
- Can minimise the memory required to process the data.

The main function of the proxy server residing on high schools' LAN is to cache frequently requested resources and to compress the data to save disk and memory resources. The deployment of a proxy server on the LAN is supported by researchers Ma and Du (2002) who argue that a proxy server can be considered as an local node along the server-client path on customer LAN.

As highlighted earlier in this sub-section, data compression can reduce storage space, improve response time and save device power consumption. Findings from the case study have shown that the majority of educators in the GTM rely on mobile devices such as modems, tablets, smart phones and laptops to access the Internet (see Theme 3 in Table 6.1). It was reported in Theme 1 and the literature review (see sub-section 2.2.3) that slow Internet connectivity makes it difficult to access electronic educational content (see sub-section 5.4.1) in many resource-constrained high schools.

According to Chen *et al.* (2003), to reduce server resources, network congestions and access latency, service providers can deploy a catching proxy server. In addition, a caching proxy server

transmits cached data rich content such as video from remote servers to clients through LAN using less expensive bandwidth (Ma & Du, 2002).

Another role of a proxy server presented in the broadband service delivery model (see Figure 6.3) is to store data requested from the content provider platform. Deploying a local caching proxy server in the high schools could accelerate service requests by retrieving content saved from previous requests made by educators or learners. This will also allow high schools to reduce upstream bandwidth usage and increase network performance. Furthermore, it will reduce the lack of technical support observed in the GTM.

This sub-section, addressed the network administration and limited bandwidth challenges faced by resource-constrained high schools. The next sub-section focuses on how the content from the proxy server can be accessed by the learners and educators.

6.4.5.3 Thin Client Computing

One of the main challenges faced by resource-constrained high schools is lack of ICTs infrastructure such as PCs, reliable internet and mobile devices as observed in the case of GTM. In addition, there is lack of technical support and the maintenance of existing infrastructure is very costly.

To alleviate lack of access to computing devices problems and at the same time addressing maintenance costs and support challenges and limited bandwidth highlighted in Table 5.1, this sub-section proposes Thin Client computing to access the educational resources stored in a local server. In the proposed broadband service delivery technical architecture, the focus of implementation of Thin Client computing is on the school's LAN. According to Michael and Shimba (2012), Thin Client computing allows users to access applications such as web pages that are executed in the local or remote server and accessed by Thin Clients diskless terminals PCs and mobile devices. Ali-Al-Mamun *et al.* (2012) and Sharma and Gandole (2014) also added that some of the key benefits of using Thin Client computing include:

- Less Power Consumption;

- Can Reduce Network Latency;
- Lower Total Cost of Ownership (TCO);
- Support of heterogeneous PC environment; and
- Lower Cost Desktop Maintenance and Support.

As illustrated by Ali-Al-Mamun *et al.* (2012) in Figure 6.5, Thin Client computing could use protocols such as Remote Desktop Protocol (RDP) and Remote Frame Buffer (RFB) to perform less computational tasks by sending keyboard and mouse events from Thin Client computer to remote server over a network.

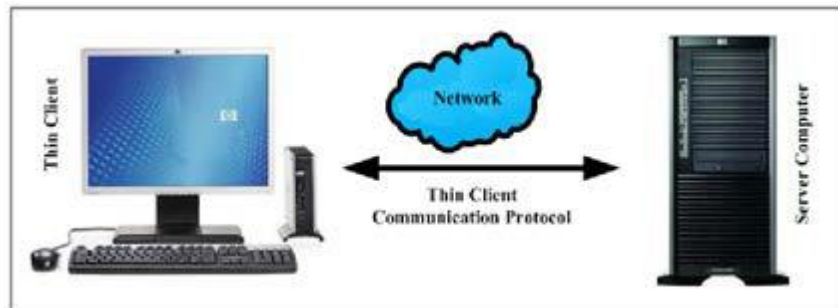

Figure 6.5: Thin Client-Server Communication

As indicated in the previous sub-section and earlier in sub-section 5.4.4, maintenance and support of ICT infrastructure and network latency is one of the main challenges faced by resource-constrained high schools. For example in school B, learners and teachers are sharing Internet connectivity using VSAT technology and the connection is not reliable and is very slow. All seven schools that participated in the study are frustrated as the schools have a limited number of computers and most of the PCs are not utilised due to high costs of maintenance of hardware.

The delivery of school resources such as question papers and text books on time still remains a challenge in South Africa; particularly in resource-constrained public high schools (see Section 2.2.3). The deployment of Thin Client based computing could also improve the delivery of school resources such as digital text books on time. The learners and teachers could still use their

mobile devices to access the resources by connecting on the local server through Wi-Fi networks.

The Thin Client based computing and internet connectivity could also improve remote administration and maintenance of the systems such as SA-SAMS. However, it must be noted that Thin Client computing also brings up some challenges. Because the architecture of Thin Client computing is a network centric IT infrastructure, the network becomes the single point of failure. Without reliable Wide Area network (WAN), accessing remote server applications and remote maintenance it could become a challenge.

6.5 Chapter Summary

This Chapter outlined the minimum requirements of BSDCM suitable for resource-constrained public schools. The broadband service delivery conceptual model was also developed, identifying the main components that provide the guidelines and support to the proposed broadband service delivery technical architecture for implementation. Furthermore, BSDCM highlighted the relationship between the identified themes detailed in Chapter Five (Section 5.4) and the role players of ICT4ED. The technical components derived from conceptual model were used to develop broadband service delivery technical architecture for implementation in the resource-constrained public high schools. The objective of this model was to satisfy the general SDP requirements highlighted in Chapter 2. In addition, the model seeks to address some of the limitations of the existing MSDP. In the next chapter we use extensive simulations, visualisation tools and comparative analysis to evaluate the effectiveness of a proposed broadband service delivery conceptual model.

Chapter 7- Evaluation of the Proposed Broadband Service Delivery Conceptual Model (BSDCM)

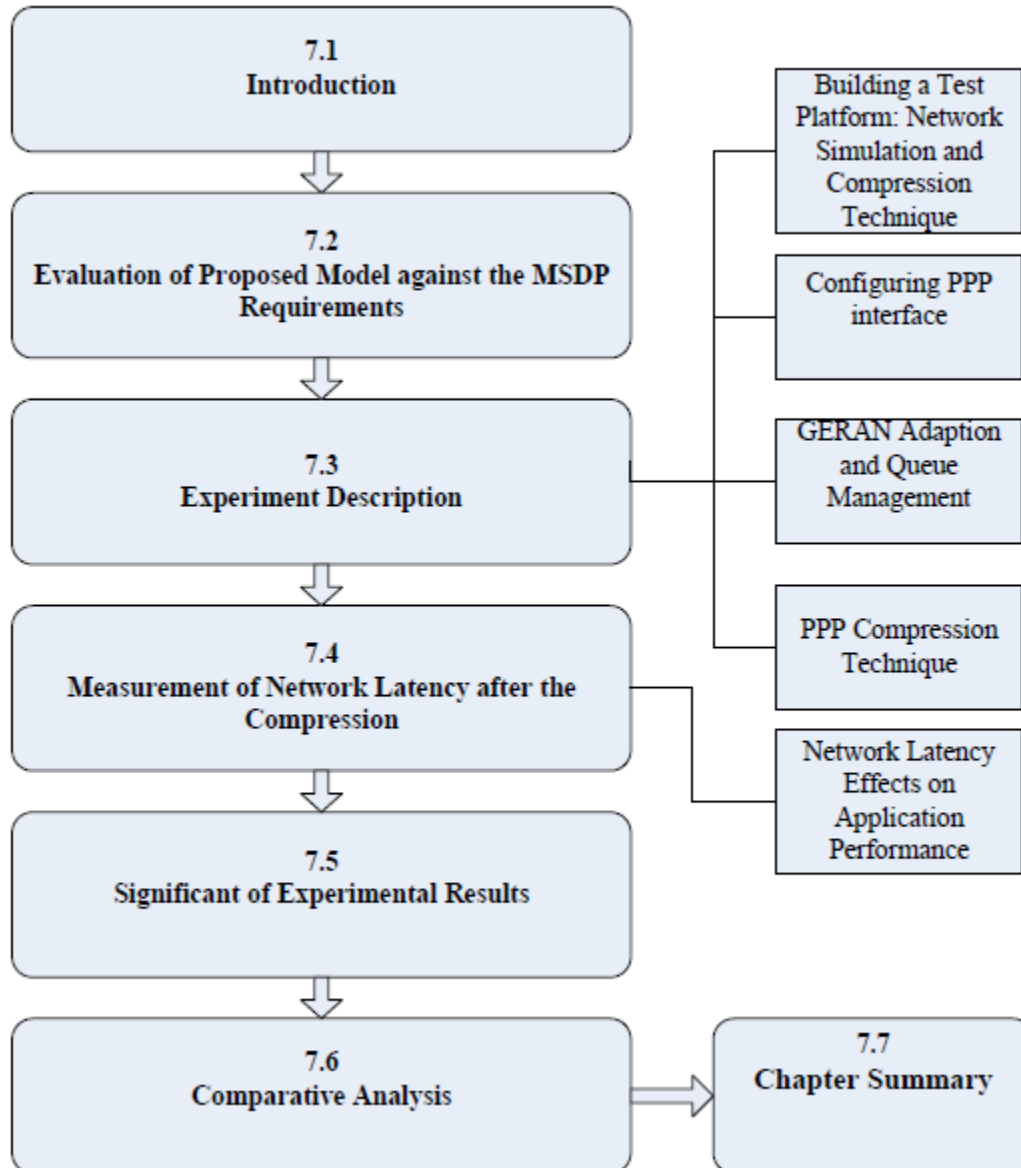

Figure 7.1: Chapter 7 Layout

7.1 Introduction

This chapter aims to compare and evaluate the effectiveness and usefulness of the proposed broadband service delivery conceptual model (BSDCM) and technical architecture for implementation against other Mobile Service Delivery Platforms (MSDPs) discussed in the

literature review (see Chapter Three). As mentioned in Chapter Four (see Section 4.4), the design evaluation guidelines seek to observe and measure the artefact to determine how it supports the solution to the research problem identified in this study. In addition, the experiment is conducted in the form of simulations and visualisation to measure the effects of the proposed model. This Chapter addresses the research sub-question:

How effective is the proposed broadband service delivery model as compared to the others?

The Chapter is structured as follows: Section 7.2 describes how the proposed broadband services delivery model could satisfy the minimum requirement of general Service Delivery Platform (SDP). In Section 7.3, we describe the detailed experiment setup using both network simulation and visualisation tools for the implementation architecture of broadband service delivery model, detailed physical network setup and testing tools used in our experiment are outlined in this Section.

Section 7.4, evaluates the performance of the network after the implementation of a compression technique against the application component of the proposed technical architecture of broadband services delivery model that could facilitate the access of education content in electronic platform. In Section 7.5, the focus is on the significance of experiment towards addressing the limitation of access to teaching and learning information in electronic platforms in resource-constrained environments. Section 7.6 adopts the comparative analysis technique to measure the effectiveness and usefulness of proposed BSDCM against other MSDPs. Section 7.7 summarises and concludes the Chapter.

7.2 Evaluation of Proposed Model against the SDP Requirements

This section evaluates the effectiveness and usefulness of the proposed broadband services delivery model against the minimum requirements of a general SDP as detailed in the previous chapters. These minimum requirements are discussed in detail in Chapter Three; they are included in this Chapter for reference purposes. The minimum requirements of MSDPs listed in

Table 7.1 serve as evaluation criteria for the proposed and developed broadband service delivery model.

Table 7.1: MSDPs comparison against minimum requirements

Minimum Requirements	Mobi4D Platform	SPRING Platform	SPICE Platform	OPUCE Platform	IMS based Platform
Minimal total life cycle cost	√	√	√	√	×
Ease of Use and Accessibility	×	×	×	√	×
Synergies and Interoperability	×	√	√	√	√
Bearer and Device Agnostic	√	√	√	√	√
Re-usable Modules	√	N/A	√	√	√
Flexibility And Extendibility	√	√	√	√	×
Leverage Available Skills	√	×	×	×	×
Scalability	×	√	√	√	√
Availability (from Rural context)	√	×	×	√	×
Performance	×	√	×	√	√

In Section 1.3 of Chapter One, this study identified the lack of suitable broadband services delivery model and Information Communication Technologies (ICTs) in the resource-constrained high schools as the major challenge to access learning information in electronic platforms.

To address the problem described above, Section 6.3 proposed a suitable broadband service delivery conceptual model for resource-constrained environments. In addition, Section 6.4

presented a technical architecture for the implementation of proposed broadband service delivery conceptual model, paying attention to technical components of the proposed conceptual model (see Figure 6.3).

Table 7.2 describes how the proposed model in this study could satisfy the minimum Service Delivery Platform (SDP) requirements for deployment in the resource-constrained environment.

Table 7.2: Evaluation of Proposed Model against the SDP Requirements

Minimum Requirements	Evaluation Narrative
Minimal total life cycle cost	In the application component of the proposed conception model (also see sub-section 6.3.2), the proposed model enables various third-party content providers to create and deploy various educational services and content for different computing platforms such as mobile devices.
Ease of Use and Accessibility	Through the case study, the content and services considered by educators and type of devices they are already using was taken into consideration when designing the model. The proposed model does meet the user requirements, since it is less complex and does not require highly skilled users. The model speaks directly to accessibility since it considers existing resources in the schools for accessing broadband services.
Synergies and Interoperability	As highlighted in sub-section 6.3.3, the proposed model is in line with the Department of Basic Education (DBE) and other initiatives, which support teaching and learning via technology-led innovations in South African schools. The proposed model enables other DBE third-party content providers such as Second Chance Matric Program, Thutong Portal and social media platforms to interface into the content provider for service provisioning.
Bearer and Device Agnostic	Reading from case study results (see Table 5.1) and literature review in sub-section 2.2.2, it is evident that the majority of teachers and learners have access to mobile devices. The educational content and services could be delivered by web and mobile application access mechanisms as proposed in the broadband service delivery conceptual model. Through the proxy server, the rich data could be compressed to address latency challenges, saving storage space, saving device power consumption and reducing transmission cost in mobile networks.
Reusable	The application (access mechanism) proposed in sub-section 6.3.2 interfaces legacy

Minimum Requirements	Evaluation Narrative
Modules	services from the content provider to any third-party applications via the Web service interface. This will enable third-party developers to re-use modules such as the Software Development Kit (SDK) to create and deploy new services through the web interface for use in resource constrained environments.
Flexibility And Extendibility	The proposed model can reduce the complexity of creating new applications and value added services by enabling third-party content providers to create and deploy various multimedia services.
Leverage Available Skills	In this study, the proposed broadband services delivery model is not evaluated against this requirement. We pay attention to delivery of digital educational content to resource-constrained environments using existing technology. However, through the intervention of other role players' components of this conceptual model, available resources should be able to support this model.
Scalability	To satisfy the scalability requirement, we proposed caching proxy server and Thin Client computing on the Local Area Network (LAN) to accelerate service requests by retrieving content saved from previous requests made by users. The proxy server could transmit cached data-rich content from a remote server to Thin client through LAN without using significant bandwidth. This could improve access to the services without requesting new hardware as the number of users increase.
Availability (from Rural context)	Existing ICT infrastructures encourage the re-use of available ICT resources to build cost-effective, user friendly and sustainable digital educational content for a resource-constrained environment. Using the available access network, this requirement was achieved by re-using the older mobile access network technologies (GSM/EDGE). The decision to adopt GERAN technology as the access infrastructure that the rural high schools could connect through is supported by popularity, high availability, fast growing and easy to access technology.
Performance	To improve the performance of access networks, sub-section 6.4.5.2 proposed a proxy server to reduce web access latency in the LAN and for optimisation and compression of Wide Area Network (WAN) data traffic.

As mentioned in Section 3.4 of Chapter Three, a majority of the MSDPs identified in the literature have some limitations (see Table 3.2) such as complexity, not suitable for rural

deployment, lack of required skilled developer, not accessible and ease of use and required significant bandwidth.

This section evaluated the proposed model against minimum requirements of the SDP. The evaluation results indicate that the proposed model from the theoretical perspective conforms to the MSDP requirements as detailed throughout the study. It is, however, worth noting that the proposed model does not consider leveraging on existing skills within the resource-constrained environments. However, an assumption is made that users in the resource-constrained environments should be able to support the model, especially since existing ICT resources are leveraged.

The following section describes the experimental setup using both network simulation and visualisation techniques for the implementation architecture of the broadband service delivery model, focusing mainly on application and required infrastructure elements.

7.3 Experimental Evaluation

In the previous section, a theoretical evaluation of the proposed conceptual model was presented. However, since resource-constrained environments are quite complex, it was therefore essential to conduct technical evaluations of the proposed model using controlled experiments in a lab environment. However, it is highly recommended that our experiments need to be replicated in a real-world settings.

Thus, the objective of this section is to describe the experimental setup using network simulation and visualisation tools for the implementation and evaluation of the suggested technical architecture of the broadband service delivery model discussed in Chapter Six (Section 6.4). This objective is achieved by conducting the network experiment in a simulated environment.

The experiment pays special attention to the simulation of a Global System for Mobile communication (GSM) and Enhanced Data rates for GSM Evolution (EDGE) GERAN access network technologies using a GSM modem and a Mikrotik router board. Furthermore, it focuses on the compression of IP header over Point to Point Protocol (PPP) data link protocol (Layer 2)

to improve Transmission Control Protocol over Internet Protocol (TCP/IP) Quality of Service (QoS) on the slow connectivity. The experimental evaluation addresses the following general SDP requirements.

- Availability;
- Performance;
- Scalability; and
- Bearer and Device agnostic.

The experiment focused on the following technical elements of the technical architecture for the implementation of proposed broadband service delivery conceptual model:

- **Applications:** We focused on the demonstration of network latency response time on Web page application access. The web application access mechanism was chosen because services such as electronic books, video, images and electronic e-mails could be accessed using mobile devices or personal computers (PCs).
- **Required Infrastructure:** Demonstration of Internet Protocol (IP) packet compression over PPP data link protocol to improve Wide Area Network (WAN) data traffic. The decision to use the router equipped with GSM module for compression of TCP/IP over PPP WAN link on existing wireless technologies was based on re-using access technologies available in resource-constrained environments.

As discussed in sub-section 6.4.1, the choice of GERAN wireless technology was motivated by availability of GERAN wireless technologies in most parts of South African resource-constrained environments, such as Greater Tubatse Municipality (GTM). To improve the performance over low-speed WAN link reported in the GTM case study, we opted to compress IP packets by using the PPP data link protocol compression technique. As highlighted by Sagar and Gothawal (2014), the technique to compress IP headers is widely used to reduce network latency and establish the direct connection in wireless networks, therefore improving network performance.

We opted to use a Mikrotik router board because it is cost effective and supports PPP compression. In addition, it has built-in features such as bandwidth test tools that can be used to demonstrate the performance of the network without purchasing any additional software licences. It should be noted though that any appropriate router could be used in realising the implementation technical architecture.

Section 7.4 evaluates the effects of network latency on a web application (access mechanism) component after the compression of TCP/IP header. A detailed physical network setup and tools used in our experiment are outlined in the next sub-section.

7.3.1 Building a Test Platform: Network Simulation and Compression Technique

As discussed in sub-section 6.4.1, the aim of this study was to identify and develop a broadband services delivery model using GSM and EDGE wireless access technologies as the foundation to provide access to digital learning information in the resource-constrained environments. To address the limited bandwidth challenges, the researcher proposes the use of a router and the Universal Serial Bus (USB) modem that support GSM/GPRS/EDGE technologies for demonstration of network optimisation and Internet Protocol (IP) packet compression of Wide Area Network (WAN) data traffic.

As highlighted by the identified research problem (see Section 1.3) and direct observations in the GTM case study, the deployment of fixed line broadband infrastructure in resource-constrained environment is hampered by vandalism, maintenance costs and geographical landscape. In this experiment, the identified access technologies are optimised by compressing IP packets over PPP WAN link to deliver educational content such as web services required by high schools for teaching and learning purposes.

To meet the general SDP requirements, which serve as a foundation of the proposed model, existing network technologies are re-used to deliver services, instead of building new network infrastructure at high cost. Furthermore, the existing infrastructure component (Theme 3) in the proposed broadband services delivery conceptual model, promotes the re-use of existing ICTs

infrastructure to build cost-effective, user friendly and sustainable digital educational content delivery model for resource-constrained environments.

In order to build a less complex and cost effective test-bed platform for PPP WAN link compression in which to operate, it was decided to use a network simulator and virtual machines. For the purpose of this experiment, the GSM/GPRS/EDGE modules and router hardware for compression is simulated by using cost effective, easy to use and accessible devices and tools as follows:

- Huawei Broadband USB Modem: Model CE0682;
- Mikrotik Router Board OS (Operating System): Model RB951G-2HnD;
- VMware Workstation;
- Graphical Network Simulator (GNS3); and
- Dotcom-Monitor web testing tool.

The Mikrotik router boards run on the software called RouterOS¹⁴. Both Graphical User Interface (GUI) and text command line can be used to configure different functions on the router. The router's built-in bandwidth test and network management tools were both used to demonstrate the performance of the PPP WAN link before and after the implementation compression protocol detailed in sub-section 7.3.3-7.3.4.

Virtualising Mikrotik router board and Huawei GSM Modem with GSM subscriber identification module (SIM) was a challenge because the model of Mikrotik router used does not have built-in GSM modules. We opted to setup physical hardware illustrated in Figure 7.2 to configure the network section of this experiment. After the setup of the hardware, the RouterOS configuration file was copied into a Mikrotik virtual machine in GNS3 platform, which runs on QEMU open-source machine simulation and emulator software. The physical connection of network element is captured in Figure 7.2.

¹⁴ For more details on RouterOS see: <http://www.mikrotik.com/software>



Figure 7.2: Network Physical Connection

7.3.2 Configuring PPP Interface

This sub-section demonstrates the access network configuration, which forms part of required ICT infrastructure component of technical architecture for implementation of the proposed broadband service delivery model. The required ICT infrastructure component of the proposed broadband service delivery model encourages the re-use of existing infrastructure to be deployed easily, is affordable, easy to maintain and support, and also suitable for resource- constrained environments. This demonstration has taken these requirements into consideration.

As illustrated in the technical architecture for the implementation of the proposed broadband service delivery conceptual model in Figure 6.3, the required infrastructure element includes the router equipped with a GSM module to accommodate existing resource-constrained environments. This sub-section demonstrates how the configuration of PPP using both a USB modem and Mikrotik router was achieved.

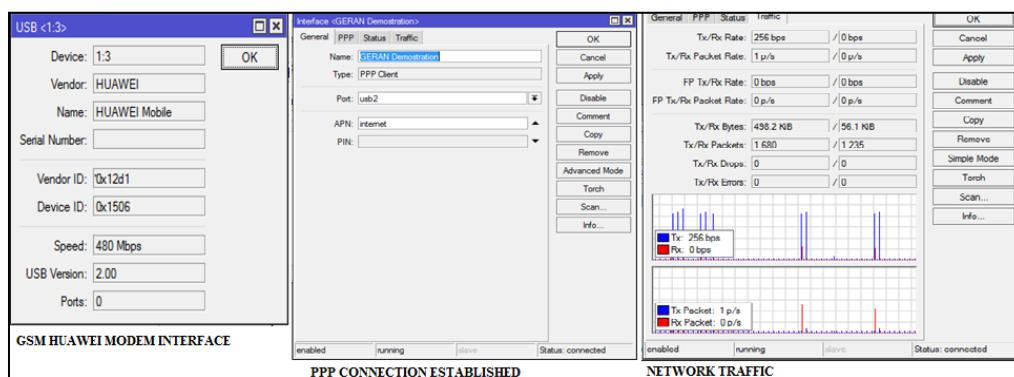

Figure 7.3: Illustration of PPP link Configuration

To accommodate the GTM case study and resource-constrained environments, which depends on GSM/GPRS/EDGE mobile devices for Internet connectivity, a USB port channel interface of Huawei modem was used to act as a GSM/GPRS/EDGE module in a Mikrotik router. As illustrated in Figure 7.3, the router established the PPP link connection through the configuration of the PPP WAN interface using a USB port channel. Figure 7.4 below depicts the network latency after to Google’s Public Domain Name Server (DNS) address (8.8.8.8) after establishing the connection.

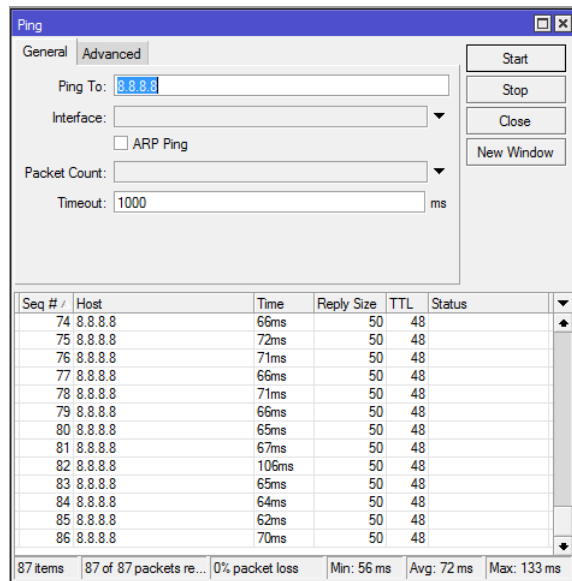

Figure 7.4: Network latency after establishing PPP Connection

The next sub-section demonstrates how PPP interface can be adapted by simulating the WAN link to accommodate the resource-constrained environment which has very low bandwidth to deliver data rich educational content.

7.3.3 GERAN Adaption and Queue Management

As indicated in the previous Chapter (see section 6.4.1), the Availability (from Rural context) requirement of the general SDP is met by re-using the current access technologies capabilities available in the resource-constrained environment. As explained by Müller *et al.* (2012), GERAN technology can provide theoretical maximum bandwidth of up to 472 kilobit per second (kb/s).

In this scenario, we consider the case study conducted in the GTM, which has basic mobile communication infrastructure with low bandwidth by adapting the GERAN technology, by limiting the Internet throughput to 256 kbps to accommodate low bandwidth links. The limitation of the bandwidth was achieved by setting up a simple queue for the traffic leaving the PPP WAN interface. The simple queue management mechanism of Mikrotik RouterOS can be used to limit the bandwidth for certain IP addresses, protocols or ports leaving the router through a specific interface.

The implementation of simple queue configuration for PPP WAN interface adaption is presented in Figure 7.5 below.

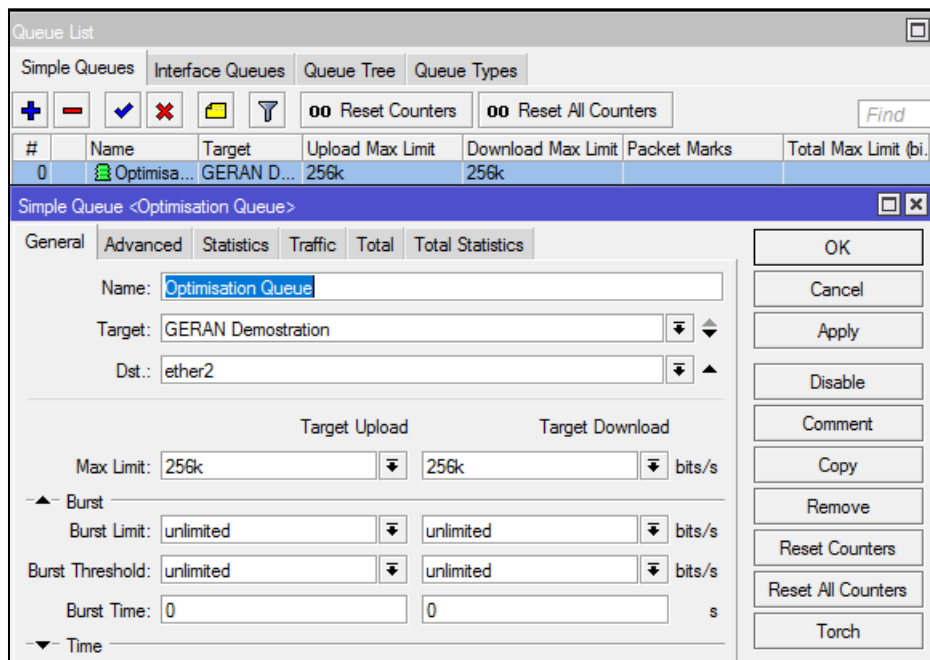

Figure 7.5: Simple Queue Adaption for PPP WAN Interface

The quality of the Internet connection after the simple queue implementation targeting PPP WAN interface was tested by measuring packet losses. The packet loss measurement is achieved by utilising Mikrotik RouterOS diagnostics tools such as ping and traceroute commands. This was illustrated by sending continuous large number of Internet Control Message Protocol

(ICMP) echo packets to Google’s Public Domain Name Server (DNS) address (8.8.8.8). The demonstration of ping for a packet loss test is captured in Figure 7.5.

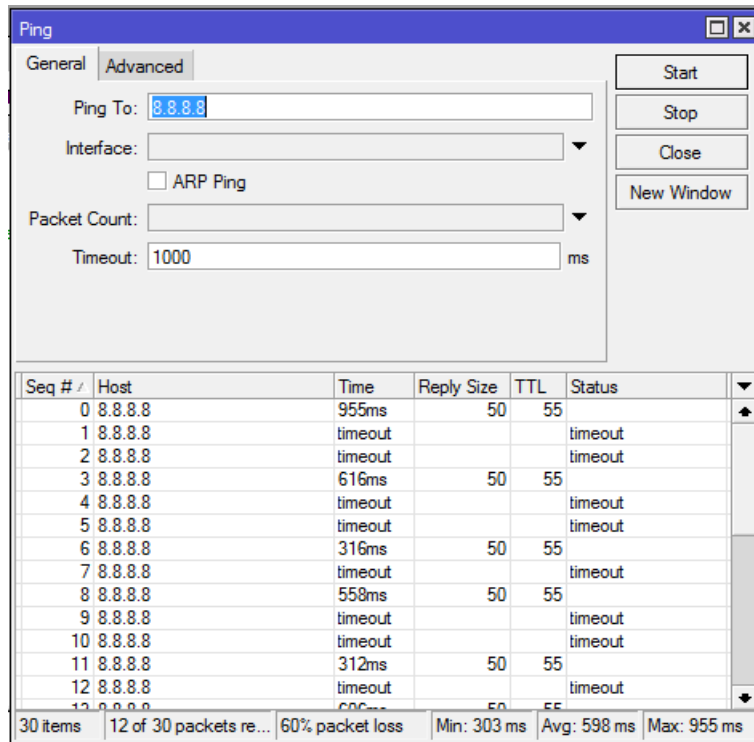

Figure 7.6: Ping test after Simple Queue Adaption targeted for PPP WAN Interface

Drawing from the ping results captured in Figure 7.5, it is evident that the quality of the Internet connection is very poor. There is sixty per cent (60%) of failed responses to Google’s public DNS and the round-trip time average of 598 milliseconds indicates that the network connectivity is very slow.

In Section 3.4 of Chapter Three, it was highlighted that the majority of MSDPs have limitations such as complexity, not suitable for rural deployment, not accessible and easy to use and required significant bandwidth. Drawing from the ping results illustrated in Figure 7.6, it could be a challenge to access data-rich content using network abstraction of components of other MSDP. The existing ICT infrastructure component of proposed broadband service delivery model promotes the re-use of same infrastructure to build cost-effective, user friendly and sustainable digital educational content delivery model for resource-constrained environments.

Sub-section 7.3.4 illustrates how existing technology could be re-used to deliver rich digital content in the resource-constrained environments.

In the next sub-section, the performance of the GERAN link is improved by implementing a compression protocol of PPP WAN interface, which is based on TCP/IP Van Jacobson header compression (VJHC) mechanism. The idea of implementing VJHC technique as explained by Wang *et al.* (2004), was to improve the performance of low-speed links by avoiding transferring of redundant information whenever possible.

7.3.4 PPP Compression Technique

The aim of this sub-section is to demonstrate how VJHC could potentially improve the access network performance in the resource-constrained environment such as GTM. Furthermore, the compression technique could be implemented together with proxy servers, application servers and Thin-Client computing in the required infrastructure component of proposed broadband service delivery model to ease access to educational content in electronic platforms. However, in this sub-section we only focus on the compression of TCP/IP header of PPP interface.

As highlighted in sub-section 6.4.5.1 of Chapter Six, the compression technique for the technical broadband service delivery architecture for implementation is adopted to improve the GERAN network link. In this experiment, we implemented the Van Jacobson header compression mechanism to reduce efficiency use of TCP/IP header. Van Jacobson's TCP/IP header compression technique is still widely used by ninety per cent (90%) of Internet hosts to address the problem of network congestion (Jacobson, 2015).

In our experiment, the Van Jacobson's compression for TCP/IP packet was implemented by configuring the PPP Authentication and Accounting link protocol, which is supported by Mikrotik RouterOS. Figure 7.7 below depicts the implementation of VJHC on the PPP profile.

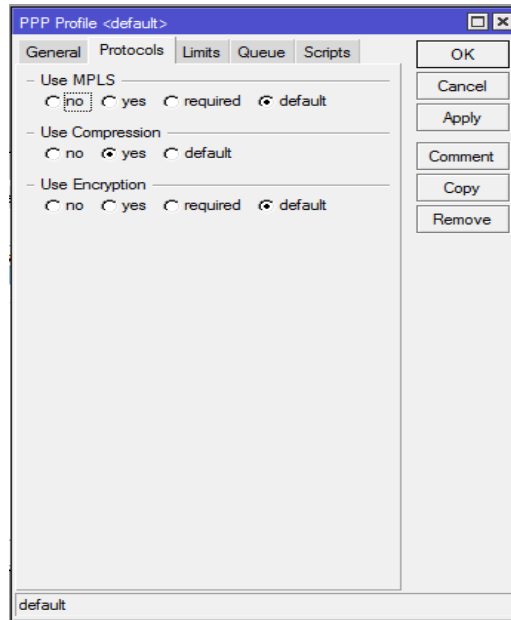

Figure 7.7: PPP WAN Link Compression

This section discussed the scope of experiment for the implementation of the proposed BSDCM. The experiment focused on application (access-mechanism) and new infrastructure components discussed in the technical architecture for the implementation of a proposed broadband service delivery conceptual model suitable for resource-constrained environment.

Section 7.4 evaluates the performance of the network after the implementation of compression technique against the application component that could facilitate the access of education content in electronic platforms.

7.4 Measurement of Network Latency after the Compression

This section presents the experimental analysis and results. We focus on network latency test results after compression of TCP/IP packet on PPP WAN Link. In addition, the subsection 7.4.1 shows the effect of network latency on application performance. The results before and after compression are summarised in Table 7.3.

The results depicted in Figure 7.8 shows that the average latency to Google's public Domain Name Server (DNS) is 279 milliseconds (ms) and connection appears to be stable with no packet loss. However, as compared to latency results presented before the GERAN optimisation with

queue management, it is evident that the latency is still high. However, the network latency results in Figure 7.8 having improved when compared to latency results presented in Figure 7.6.

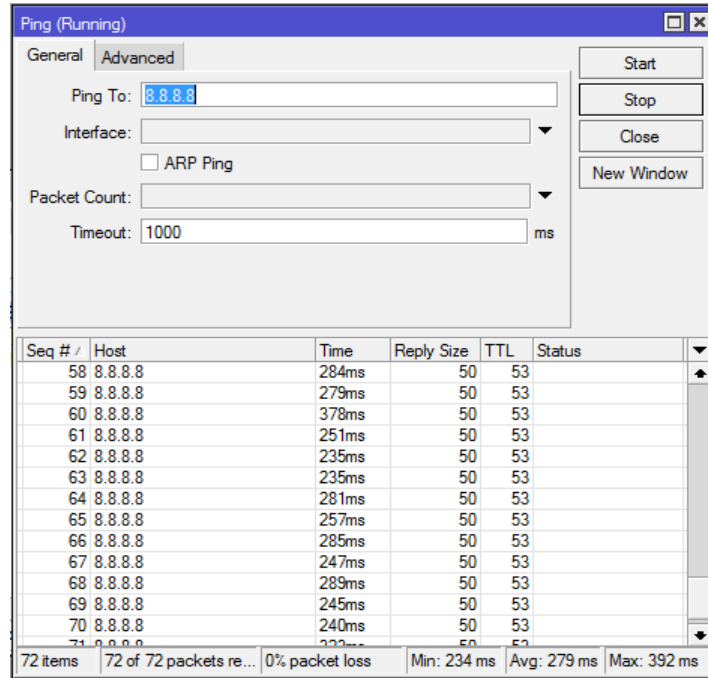

Figure 7.8: Network Latency Test after Compression of PPP WAN Link

Table 7.3 summarises network latency results. The results indicate that after optimisation of the WAN link, which accommodates the low bandwidth environment there was packet loss (high latency of 598ms). To address the packet loss problem, we compressed the TCP/IP packet on the WAN interface, which improved the average latency to 279ms.

Table 7.3: Network Latency Comparative Results

Results	Before PPP Queue Management Adoption (see Figure 7.4)	After PPP Queue Management Adoption (see Figure 7.6)	After Compression (see Figure 7.8)
Packet loss	No	Yes	No
Average latency	72ms	598ms	279ms

This section demonstrated how TCP/IP packet compression could improve network latency on the slow links. However, it should be noted that the network latency is still high as compared to

the test conducted before limiting the PPP network interface using the simple queue management mechanism. The network latency is still high because the download and upload speed was throttled to maximum 256kb/sec on the PPP interface to accommodate the resource-constrained environment.

The next subsection focuses on the performance of a web page application using the current testbed platform.

7.4.1 Network latency effects on application performance

The main aim of this sub-section is to measure how fast a web page completely loads after it has been requested by the end user under the illustration scenario captured in Section 7.3.4. Accessing other content of the web page such as e-mail, IM, e-books and images could be addressed by proposed proxy and application servers and Thin Client-Server computing on schools' LAN, which is beyond the scope of this experiment.

In the previous chapter (section 6.4.3), the web application mechanism to access electronic educational services such as web based electronic mail (e-mail), Instant messaging (IM), electronic books (e-books), video content and web resources (World Wide Web) was proposed. To ease access to digital content on school's Local Area Network (LAN), we proposed application and proxy servers components as the required infrastructure for broadband service delivery technical architecture for implementation.

Acceptable web browsing response time as recommended by standardisation organisations such as 3rd Generation Partnership Project (3GPP), Broadband Forum and International Telecommunication Union (ITU) could range between two to four seconds per page (2-4s) (Adtran White Paper, n.d.).

In the scenario captured in Figure 7.9, we used Mikrotik RouterOS ping command to test the website's response time by sending ICMP echo packets to a YouTube, Google, Microsoft and Yahoo websites. As indicated in Section 2.2.1 and Section 5.4.1, these websites could facilitate e-learning content. As illustrated, the maximum average response time measured

between four websites was 559.5 ms (0.5595s), which is within the web latency benchmark recommended by Adtran White Paper (n.d). The results are only focusing on the round-trip time (RTT) to respective web servers.

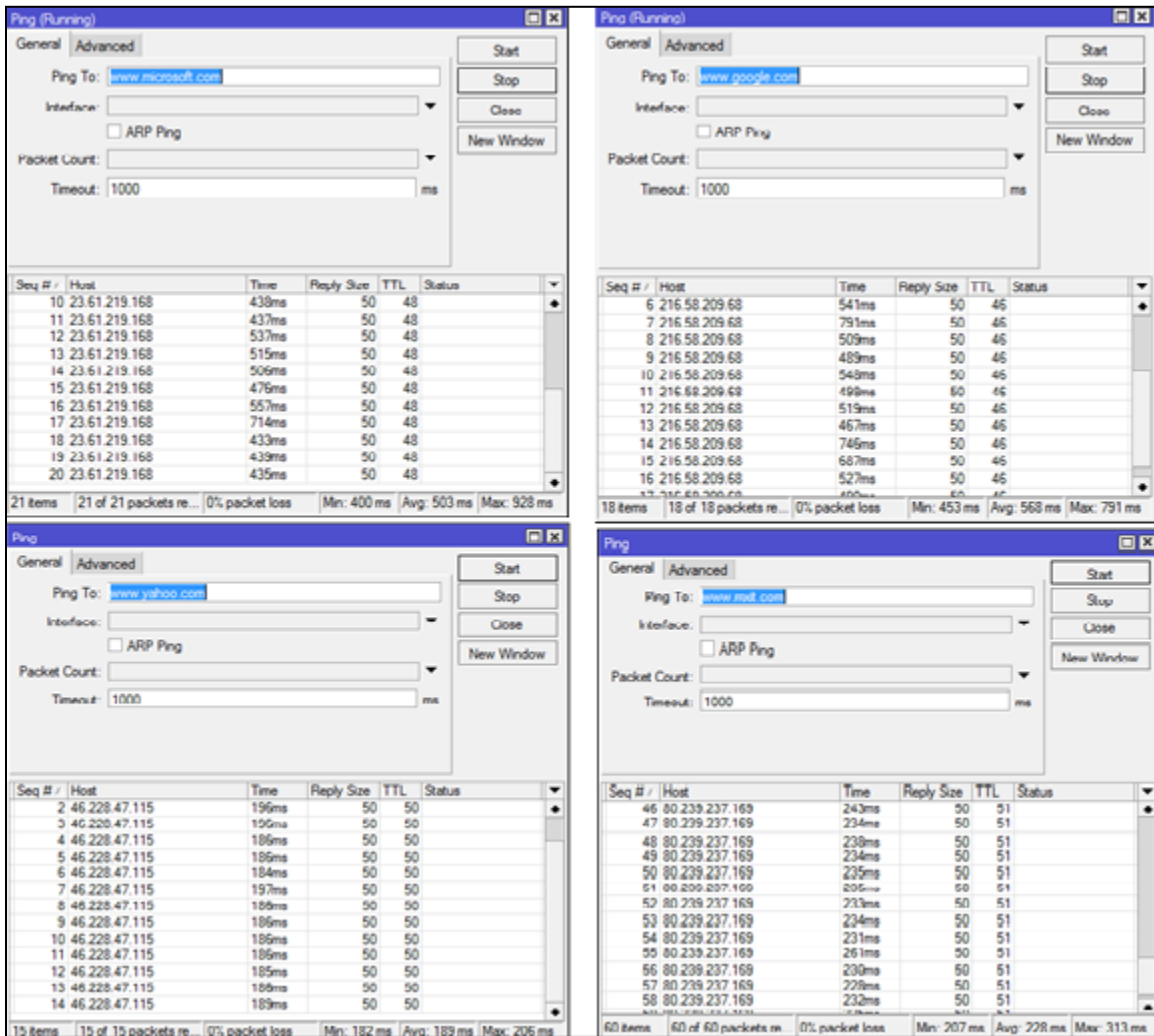

Figure 7.9: Web Servers Response Time

In addition to ping tests conducted above, the Dotcom-monitoring tool was used to test the time it takes to load identified websites of different designs. Dotcom-monitor was used because it is capable to do load time testing of all page elements from various browsers, including mobile browsers. In addition, the latency could be reduced by using local (South African) test server, which could provide more accurate results. The process followed to test the loading time using compressed PPP WAN link configuration is described in Figure 7.10 below.

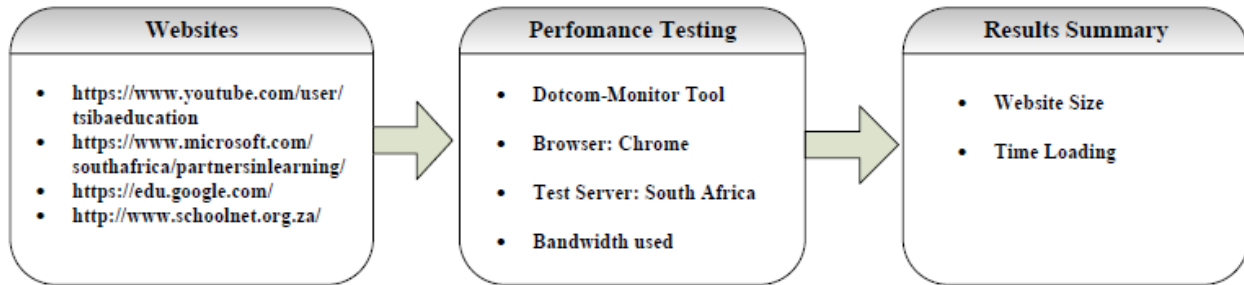

Figure 7.10: Process Followed to Test the Educational Resources Websites

Figure 7.10 above depicts the websites that contains educational resources, performance testing process and the results summary. The purpose of this experiment was to test loading time of identified website.

Drawing from the results presented in Figure 7.11 and Figure 7.12, the average time it takes to load the webpages depends on the size of the website. The data rich websites such as Youtube and Microsoft take longer than websites such as Google. The results shows that on average it takes 2.5 seconds to load webpages with less data rich content and 5 seconds to load data rich websites.

Performance Report

URL: <https://www.youtube.com/user/tsibaeducation>
 Monitoring Date and Time: 6/29/2017 at 7:50:51 AM
 From: South Africa
 Browser Type: chrome
 Browser Visit: 1st visit

Summary	Performance	Waterfall Chart
Monitoring Date Time	6/29/2017 7:50:51 AM	
Monitor	South Africa	
Total Size in KB Total	360.06	
Total Number of Objects	18	
Time loading	00:03.09	

Performance Report

URL: <https://www.microsoft.com/southafrica/partnersinlearning/>
 Monitoring Date and Time: 6/29/2017 at 7:58:56 AM
 From: South Africa
 Browser Type: chrome
 Browser Visit: 1st visit

Summary	Performance	Waterfall Chart
Monitoring Date Time	6/29/2017 7:58:56 AM	
Monitor	South Africa	
Total Size in KB Total	209.68	
Total Number of Objects	18	
Time loading	00:02.13	

Figure 7.11: Webserver Page Loading using Dotcom-Monitoring tool

Performance Report

URL: https://edu.google.com/
Monitoring Date and Time: 6/29/2017 at 8:08:37 AM
From: South Africa
Browser Type: chrome
Browser Visit: 1st visit

Performance Report

URL: http://www.schoolnet.org.za/
Monitoring Date and Time: 6/29/2017 at 8:14:28 AM
From: South Africa
Browser Type: chrome
Browser Visit: 1st visit

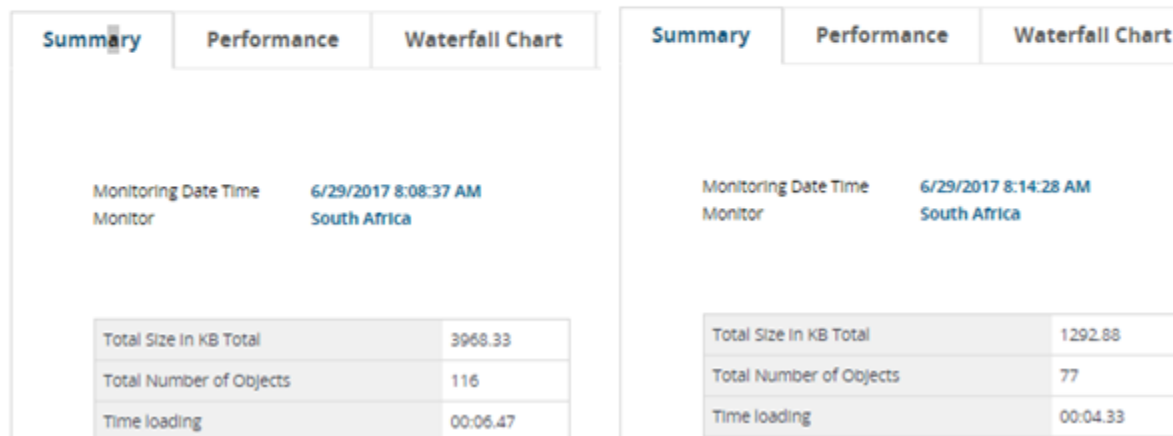

Figure 7.12: Webservice Page Loading using Dotcom-Monitoring tool

As discussed in previous chapter (section 6.4.3), the web application was proposed as a mechanism to access various educational content in proposed technical architecture for implementation. We proposed proxy servers components as the required infrastructure to reduce the response time for data rich content websites such as YouTube and google education tested above. Using web application mechanism addresses application component of proposed BSDCM.

This section presented the experimental evaluation of the proposed broadband services delivery model. The evaluation measured how TCP/IP packet compression could improve network latency on the slow links. Furthermore, the section demonstrated web browsing response time and web page loading time which could be used to access various educational contents in electronic platform.

The following section discusses the significant of experiment conducted in Section 7.3.

7.5 Significant of experimental results

The main aim of this experiment was to test how fast web pages can completely load using the implementation of Van Jacobson's TCP/IP header compression on PPP link protocol. In Chapter Six, the researcher investigated and developed the broadband service delivery conceptual model that could address the challenges of lack of digital educational content faced by resource-constrained public high schools. The existing infrastructure component of a developed conceptual model encouraged utilisation of existing ICTs to build sustainable, less complex and cost-effective broadband service delivery model for resource-constrained environment.

Furthermore, an application component promotes the adoption of cross-platform applications, such as the web to deliver various educational services and content in different computing platforms. As highlighted in Section 6.3.2, the application should be compatible with multiple operating systems and work on different types of end-user devices such as mobile phones, tablets, laptops, and so forth. In this experiment web application was used to meet device agnostic requirement.

To meet the utilisation of existing infrastructure and application requirements, we re-used existing GERAN wireless access technologies to test web pages' response time after the implementation of a TCP/IP header compression on PPP link protocol. To address scalability requirement of general SDP, we chose to use GERAN technology access network as it is available in most part of South Africa.

From the scenario presented in sub-section 7.3.4, the results have shown that the compression of TCP/IP header over PPP WAN link could potentially improve the response time to access web pages. The web application could be used as a mechanism to access various educational services summarised in sub-section 6.4.2. These experimental results could significantly address the limitation of access to teaching and learning information in electronic platforms in the resource-constrained environments.

The experiments and results are based on using Huawei Broadband USB Modem and Mikrotik Router Board OS ICT equipment. However, other different vendors' devices having more or less the same features and tools could achieve the same results.

7.6 Comparative Analysis

This section presents additional evaluation results in the form of comparative analysis. The comparative analysis technique was conducted to measure the effectiveness and usefulness of proposed service delivery model against other MSDPs. As Hevner *et al.* (2004) explained, the design evaluation guideline of the Design Science Research process seeks to observe and measure the artefact, to determine how it supports the solution to the problem. Comparative analysis was conducted to assess the proposed solution against existing solutions, focusing on the benefits and drawbacks of solutions in the resource-constrained environment context.

According to Pickvance (2005), comparative analysis as a research design focuses on the explanation of differences and similarities of different variables. The comparative analysis used for evaluating the proposed model against other MSDPs studied in literature (Chapter Three) is based on a qualitative comparative analysis approach (QCA). The QCA method empirically examines the relationships between the different outcomes (variables) of interest (MSDPs in this study) and the availability of its predictors (minimum SDP requirement) (Li, Tao & Wang, 2015).

The comparative evaluation of proposed service delivery model against other existing MSDP is summarised in Figure 7.5. The minimum requirements of general SDP were used as guidelines to measure existing MSDPs and proposed broadband services delivery model. A detailed explanation of the evaluation follows in the next paragraph.

In Chapter Three, the researcher explored various MSDPs through the literature, the researcher identified that most MSDPs do not meet all the general requirements that SDPs should address, particularly in the resource-constrained environments. Table 7.4 demonstrates a comparative analysis of proposed model with other MSDPs against the SDP general requirements.

Drawing from Table 7.4, it is evident that the majority of existing MSDPs are not suitable for resource-constrained environments. The platforms such as Service Platform for Innovative Communication Environment (SPICE), Service Platform for Reconfigurable and Intelligent services in Next Generation mobile communication (SPRING) and IP Multimedia System (IMS)-based platform depends on Next Generation Networks (NGN) All-IP mobile and fixed-access networks, which requires significant bandwidth. However, drawing from the literature, the penetration of broadband in the resource-constrained environment still remains a challenge in South Africa (ITU, 2014; ITU & UNESCO, 2015). Therefore, these platforms could not meet availability (from rural context) requirements of general SDPs.

In terms of addressing the accessibility and ease of use requirements, the literature has shown that platforms such as IMS, Mobi4D, SPICE, and SPRING are very complex and costly to deploy and still do not offer the flexibility that end-users expect. The Mobi4D and SPICE are based on Java application programming interface (API) for Integrated Networks Service Logic Execution Environment's (JAIN SLEE) architecture, the complexities of the Mobicents JAIN SLEE platform and the resources, such as timers and external databases, have a major impact over the scalability and performance of the platforms.

The proposed broadband service delivery model seeks to address the gaps identified in Table 7.4 as follows:

- **Availability (from rural context):** The existing infrastructure component of proposed model encourages the re-use of existing access networks to delivery digital content in the resource-constrained environments.
- **Scalability and Performance:** This requirement was addressed in the required infrastructure component of technical architecture of proposed model, which promotes the use existing ICT infrastructure (network technologies). The required infrastructure addresses some of the short comings of the existing ICT infrastructure.
- **Accessibility and Ease to use:** The Application (Access Mechanism) component refers to cross-platform application such as web to deliver services in different computing platforms.

Table 7.4: Comparative Analysis of Proposed Model against the SDP Requirements

Minimum Requirements	Mobi4D Platform	SPRING Platform	SPICE Platform	OPUCE Platform	IMS based Platform	BSDCM
Minimal total life cycle cost	√	√	√	√	×	√
Ease of Use and Accessibility	×	×	×	√	×	√
Synergies and Interoperability	×	√	√	√	√	√
Bearer and Device Agnostic	√	√	√	√	√	√
Re-usable Modules	√	Unknown	√	√	√	√
Flexibility And Extendibility	√	√	√	√	×	√
Leverage Available Skills	√	×	×	×	×	N/A
Scalability	×	√	√	√	√	√
Availability (from rural context)	√	×	×	√	×	√
Performance	×	√	×	√	√	√

Although proposed BSDCM addresses some of the limitations, it is important to note that the proposed model does not consider other general SDP requirements such as leveraging on existing skills within the resource constrained environments.

7.7 Chapter Summary

The main objective of this chapter was to measure the effectiveness and usefulness of the proposed broadband service delivery model against the requirements of the SDPs. This was achieved by evaluating the proposed model against other existing MSDPs. To address some of the short comings of existing MSDPs such as complexity, scalability and performance, controlled lab experiments in the form of simulation and visualisation were conducted. To

improve the performance over low-speed WAN link reported in the GTM case study, we opted to compress the IP packet by using of PPP data link protocol compression technique. The experimental results could significantly address the limitation of access to teaching and learning information in electronic platforms in the resource-constrained environment.

The experiment only focused on the performance improvement of the access network element of required ICT infrastructure component of technical architecture. This was achieved by implementing the TCP/IP header compression of PPP interface to accommodate low-speed links; the idea was to avoid the transmission of redundant information on the network as far as possible. Furthermore, when testing network latency, we concentrated on the amount of time it takes to reach the web server after it was requested by the end user. In addition the loading of rich content such as multimedia services was also tested in this experiment. It is, however, worth mentioning that with the implementation of proxy servers and thin client computing as proposed in the previous chapter (see Sub-section 6.4.5) the delivery of data-rich content could be improved.

Chapter 8- Conclusion and Recommendations

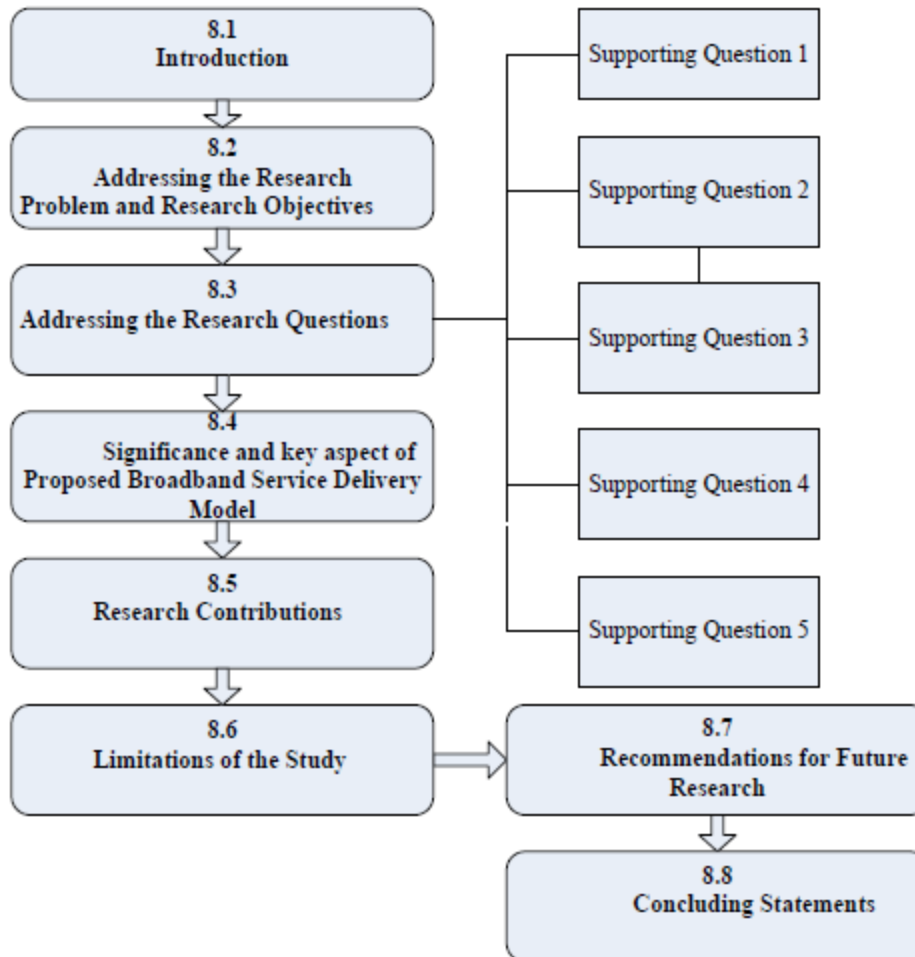

Figure 8.1: Chapter 8 Layout

8.1 Introduction

This final chapter consolidates and summarises the findings of the research by focusing on the problem statement, research objectives and research questions in Chapter One. Furthermore, we highlight the significance of the proposed broadband services delivery model. The identified challenges and limitations of the study are also discussed. The chapter also gives recommendations for future research based on the limitations.

The chapter is structured as follows: Section 8.2 describes how research problem and objectives were addressed. Section 8.3 outlines how main research question and five (5) supporting questions raised in Section 1.5 of Chapter One were addressed. The significant and the key aspect of proposed Broadband Service Delivery Model were described in Section 8.4. Section 8.5 of this chapter briefly explained the direct and indirect contributions of the study. Limitations of this study are explained in Section 8.6. Recommendations and future were presented in Section 8.7. The chapter concludes with final conclusion statement in Section 8.8.

8.2 Addressing the Research Problem and Research Objectives

Broadband infrastructure is of critical importance to bridge the digital gap between the rural and urban schools in South Africa. However, in South Africa, schools located in resource-constrained environments have low or non-existing broadband infrastructure (DOC, 2013). According to Anderson *et al.* (2012) and Herselman & Botha (2014:1), a resource-constrained environment is an environment where there are low-income communities, low bandwidth, power and network connectivity are scarce and expensive and cultures where people are unfamiliar with or afraid of technology. The lack of broadband infrastructure in the resource-constrained environments is attributed to a number of challenges, such as lack of electricity, security, fixed-line deployment costs and maintenance, poverty, lack of technical skills and geographical landscape.

To address some of the challenges, the study was undertaken to investigate and develop a broadband services delivery model using existing Global System for Mobile communication (GSM) and Enhanced Data rates for GSM Evolution (EDGE) (GERAN) wireless technologies as the foundation to provide limited access to digital learning information to resource-constrained public schools. This objective has been met: the broadband service delivery conceptual model (BSDCM) suitable for resource-constrained environments was developed in Chapter Six (see Section 6.3) and its technical architecture for the implementation proposed BSDCM was evaluated in Chapter Seven.

In addressing the research problem and research objectives, the study employed the Design Science Research (DSR) methodology to develop and evaluate a broadband services delivery

model suitable for resource-constrained environments. To complete the relevant cycle of Information Systems Research Framework of DSR, the exploratory case study was conducted in the resource-constrained public high schools located within the Greater Tubatse Municipality (GTM).

This study was guided by one (1) main research question and five (5) supporting questions. The next section describes how the research questions were addressed.

8.3 Addressing the Research Questions

The aim of this section is to address the main research question and five (5) supporting questions raised in Section 1.5 of Chapter One. The main research question was as follows:

What is the appropriate model for delivering broadband services (e.g. digital learning information) to resource-constrained public high schools in South Africa?

The objective of this main question was to identify and develop a broadband services delivery model using GSM and EDGE wireless technologies to resource-constrained public high schools in South Africa. The choice of GSM and EDGE wireless technologies as the access technology was motivated by popularity, high availability, fast growing and easy to access of GERAN technology as expressed by Axelsson *et al.* (2006) and Louw & Dörflinger (2010).

In this section, we begin by reviewing how supporting questions were answered.

The following supporting questions (SQs) from Chapter One (see Section 1.5) are restated to assist in addressing the main research question and accomplishing the main objective of this study:

Table 8.1: Supporting Questions and Objectives Achieved

Supporting Questions	Objective Achieved
SQ-1: What challenges are faced by resource-constrained public high schools regarding the lack of access to digital learning information?	Conducted an exploratory case study in the resource-constrained public high schools located within the GTM and literature review to highlight some of the challenges faced by educators and learners regarding lack of access to learning information in electronic platforms. The challenges are summarised in Table 8.2.
SQ-2: What are the value-adding services and digital content considered by public high schools as relevant and useful?	This question was addressed in the form of exploratory case study and literature review. Accessing real-time material over Internet was seen as the main requirement for teaching and learning in the classrooms.
SQ-3: What broadband Mobile Service Delivery Platforms (MSDPs) are available to address value adding services and digital content problems required by resource-constrained public high schools?	Chapter Three of this research explored existing MSDPs, focusing on basic requirements of general Service Delivery Platform (SDP) and the benefits and limitations of existing platforms.
SQ-4: How to design an appropriate broadband service delivery conceptual model for seamlessly delivering broadband services (e.g. digital learning information) to resource-constrained public high schools?	In Chapter Six, proposed BSDCM was investigated and developed and its technical architecture for the implementation was also presented.
SQ-5: How relevant and useful is the proposed broadband service delivery model as compared to other existing broadband service delivery models?	To measure the effectiveness and usefulness of proposed BSDCM, Chapter Seven conducted comparison analysis and technical evaluation of the proposed model using controlled experiments in a lab environment.

Review of supporting questions and objectives is summarised as follows:

8.3.1 What Challenges are faced by Resource-Constrained Public High Schools Regarding the Lack of Access to Digital Learning Information?

The objective of the first supporting question was to identify the challenges faced by resource-constrained public high schools regarding the lack access to digital learning information. To address this supporting question, an exploratory case study was conducted in the resource-constrained public high schools located within the GTM. Chapter Five specifically Theme 4 (see sub-Section 5.4.4) of the case study results, highlighted some of the challenges faced by educators and learners regarding lack of access to learning information in electronic platforms. The main themes, research questions, and some of the challenges were summarised in Table 5.2. Furthermore, through the literature conducted in Chapter Two, particularly Sub-section 2.2.3, it was highlighted that South African public schools still have challenges of lack of ICTs, particularly schools in resource-constrained environments. The challenges are briefly summarised in Table 8.2.

Table 8.2: Summarised challenges of lack of ICTs resource-constrained public high schools

Research Supporting Question	Results
What challenges are faced by resource-constrained public high schools regarding the lack of access to digital learning information?	<ul style="list-style-type: none"> • Poor performance of learners; • Limited resources for teaching ; • Learners and teachers are excluded from digital world; • Traveling costs and Information sharing within learners & other schools; • Lack of ICT skilled and experienced teachers; • Remotely situated rural schools; • Expensive Internet access and equipment; • Resistance to technological changes.

8.3.2 What are the Value-Adding Services and Digital Content Considered by Public High Schools as Relevant and Useful?

This supporting question explores value-adding services and digital content considered by public high schools as relevant and useful for teaching and learning. This question was also addressed in the form of exploratory case study in Chapter Five Themes 1 and 3 identified value adding

services and content considered by resource-constrained public high schools, particularly in GTM. Both themes identified the existing ICTs and also general ICTs requirements for teaching and learning that resource-constrained schools may not have. Sub-section 5.4.1 and Sub-section 5.4.3 summarised the requirements for teaching and learning using digital learning information.

Drawing from the literature and case study findings, it was reported that having access to real-time material such as video, Interactive teaching programs (ITP) and web services through reliable Internet connection was seen as the main requirement to facilitate teaching and learning. Some of the value-adding services digital content derived from the themes and literature are summarised as follows:

- Video services (e.g. YouTube, video conferences,);
- Web services (e.g. to access previous papers, Siyavula and research);
- E-mail (e.g. communicate with other educators and department correspondence);
- E-books (access to latest books in electronic format);
- Internet connectivity;
- Computer skills;
- Educational games; and
- Interactive teaching programs (ITP).

8.3.3 What Broadband Mobile Service Delivery Platforms (MSDPs) are Available to Address Value Adding Services and Digital Content Problems Required by Resource-Constrained Public High Schools?

The objective of the third supporting question was to explore and discuss a number of existing MSDPs that could be used to facilitate delivery of educational services in digital platforms to public high schools situated in resource-constrained environments. In Chapter Three, an extensive literature review was conducted, focusing mainly on basic requirements of a Service Delivery Platform (SDP) and the benefits and limitations of existing MSDPs for resource-constrained environment deployment. Basic requirements of SDPs could also serve as the foundation of proposed broadband services delivery model. Drawing from the literature review, existing MSDPs were discovered to have some limitations, such as:

- Complexity;
- Lack of suitability for resource-constrained environments;
- Not accessible;
- Lack of ease to use; and
- Required significant bandwidth to deliver digital content.

The gaps identified in the literature review were taken into consideration when designing the proposed broadband service-delivery model.

8.3.4 How to Design an Appropriate Broadband Service Delivery Conceptual Model for Seamlessly Delivering Broadband Services (e.g. digital learning information) to Resource-Constrained Public High Schools?

The purpose of this supporting question was to investigate and develop a suitable BSDCM that could address the challenges raised in the literature review (Chapter Two and Three) and GTM case study findings (Chapter Five). In Chapter Six (see Section 6.3), the BSDCM was designed based on a set of requirements developed from the themes derived from the GTM case study as discussed in Chapter Five (see sub-sections 5.4.1 and sub-section 5.4.2), and summarised in Table 5.2. In addition, Section 6.4 presented the technical architecture for the implementation of proposed BSDCM, the basic requirements of general SDP outlined in Chapter Three (see Section 3.3), existing infrastructure, required infrastructure, applications and digital educational services components were the derived building blocks for the technical architecture.

8.3.5 How Relevant and Useful is the Proposed Broadband Service Delivery Model as Compared to the others?

The aim of this supporting question was to measure the effectiveness and usefulness of proposed BSDCM against the requirements of the general SDPs. In Chapter Seven (see Table 7.1), the proposed BSDCM was evaluated against the requirements of general SDPs. The evaluation results indicated that the proposed model from the theoretical perspective conforms to the MSDPs requirements.

In addition to theoretical evaluation, it was essential to conduct the technical evaluation of the proposed model using controlled experiments in a lab environment to accommodate complex resource-constrained environments. The main aim of these experiments, amongst other tests, was to measure how fast web pages can completely load and reach the server using the Dotcom-Monitor testing tool and ping tests. This was done after the implementation of Van Jacobson's Transmission Control Protocol over Internet Protocol (TCP/IP) header compression on Point to Point Protocol (PPP) link protocol over the slow network connection using GSM and EDGE wireless technologies. The results have shown that the compression of TCP/IP header over PPP Wide Area Network (WAN) link could potentially improve the response time to access web pages. The web application could be used as a mechanism to access various educational services summarised in Sub-section 6.3.2.

The Sub-sections 8.3 above briefly discussed how the supporting questions (SQ1-SQ5) were addressed. Figure 8.2 summarises how the supporting research questions were addressed in this thesis.

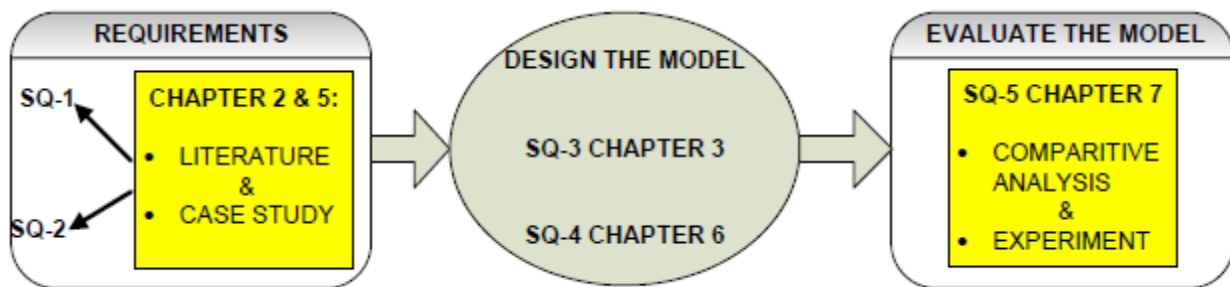

Figure 8.2: Supporting Research Questions

The objective of this main question as indicated in Section 8.3 was to identify and develop a broadband services delivery model using GSM and EDGE wireless technologies to resource-constrained public high schools in South Africa. The answer to the main research question was presented in Chapter Six. Section 6.3 presented the BSDCM that could potentially facilitate access to broadband services since it considers existing ICT resources in the resource-constrained environment. Evaluation activity demonstrated that the BSDCM could provide a good platform to deliver broadband services with the limited bandwidth.

In this section, the goal was to review the supporting research questions, and the extent to which they were addressed to satisfy the main research problem. The next section, Section 8.4, discusses the significance and the key aspects of the proposed BSDCM.

8.4 Significance and key aspects of Proposed Broadband Service Delivery Model

Drawing from the literature, the majority of existing broadband service delivery platforms have some limitations such as complexity, not suitable for rural deployment, not accessible and requirements for significant bandwidth. To address these limitations, we proposed a cost-effective and less complex BSDCM that could enable delivery of broadband services using available wireless technologies in the resource-constrained environment. The proposed BSDCM is made up of both technical and non-technical components that consider the requirements of all role players, ICT challenges, policy makers and Information Communication Technology for Education (ICT4ED) interventions. The relationships and detailed functions of model components were discussed in Section 6.3. The key components of the proposed BSDCM as outlined in Section 6.3 are summarised as follows:

- **Education Challenges:** Limited Educational Resources, Crime and Infrastructure;
- **Universal Access:** Infrastructure, Affordable Internet, and Education;
- **ICT4ED Role Players:** Community, Educators, Learners, DBE and NGOs;
- **Educational Services:** Digital Content, Internet Access and Interactive Teaching Program (ITP);
- **Applications:** Compatibility, Device-Agnostic, Easy to Support and Heterogeneous Networks;
- **Existing ICT Infrastructure:** Networks, Devices and Software;
- **Required ICT Infrastructure:** Affordable, Easy to Maintain and Suitable for the Environment; and
- **Policies and Processes:** DBE ICT Policies, DBE Programs and ICT4ED White Paper.

8.5 Research Contributions

Various South African government departments in partnership with Non-Government Organisations (NGOs) introduced a number of programs and projects to support traditional

teaching and learning using modern ICTs. Therefore, owing to a lack of a suitable broadband services delivery model to deliver educational content in resource-constrained environments, this study developed and evaluated a broadband services delivery conceptual model. The contributions of the research study are divided into direct and indirect contributions and they are briefly explained as follows:

Table 8.3: Direct and Indirect Research Contributions

Direct Contribution	Indirect Contribution
Provides a holistic and consolidated understanding of the teaching and learning challenges faced by resource-constrained public schools in the digital era.	Informs other ICT4ED stakeholders about the nature of value adding services and content considered by high schools as relevant and useful.
Understanding the existing and new ICT requirements for teaching and learning.	Demonstrates the impact of ICTs adoption in the resource-constrained high schools in GTM and Significantly contributes to the DBE's programs such as Operation Phakisa ICT in Education Lab and turnaround plan called Action Plan 2014 towards the realisation of Schooling 2025.
Designed, developed, and evaluated a unique artefact that appreciates existing technologies in resource-constrained environments and also allows for the deployment of new ICT infrastructure. The model also compensates for the low speed Internet connectivity to facilitate the delivery of digital services and content to resource-constrained public high schools	Proposed BSDCM could be used by Internet Service Providers (ISPs) to deliver other broadband services not related to teaching and learning in rural areas.

8.6 Limitations of the Study

Section 1.8 has shown that this study was limited to resource-constrained public schools based in Greater Tubatse municipality (GTM) in the Limpopo province. The case study findings cannot be directly generalised to other resource-constrained municipalities in South Africa. Other resource-constrained municipalities might have unique problems such as geographical location and state of existing communication infrastructure might be different to GTM. Due to time and

resource limitations, the researcher focused on the ten (10) resourced-constrained high schools in the GTM. The researcher focused on secondary schools because of a high demand of ICTs in high schools as compared to primary schools.

Section 1.8 also explained that the study only focused on the utilisation of wireless access technologies available in the GTM. Due to a lack of other access technologies discussed in Section 2.3, the choice of access technology for implementation and evaluation of proposed BSDCM was influenced by current GERAN wireless technologies.

A further limitation is that the experimental evaluation focused mainly on application and infrastructure components of technical architecture for implementation of BSDCM. Furthermore, the experiment addressed availability, performance, scalability and bearer and device agnostic general SDP requirements. The assumption was made that users in the resource-constrained environments should be able to support the model, especially since existing ICTs resources are leveraged.

8.7 Recommendations for Future Research

This section presents the recommendations for other researchers, policy makers and all ICT4ED stakeholders who may want to adopt the proposed BSDCM in a real environment. Based on the research findings, the results show that having access to learning material in electronic platforms could afford educators and learners the opportunity to interact with the outside world, improve learning and teaching and also could benefit the community as the whole. The proposed model addressed some of the challenges regarding lack of access to educational content. However, there are still limitations, which may require further research and development.

8.7.1 Network Technologies

The proposed model was developed and evaluated based on access network technologies. In order for the content providers to benefit from the proposed model, it is recommended that proposed BSDCM be tested on their backhaul network infrastructure. Furthermore, although the proposed BSDCM encourages the re-use of existing popular GERAN technologies to deliver broadband services, comparison analysis with other network technologies should be conducted to

establish if the TCP/IP header compression on PPP protocol improves the performance of the network.

It is also appreciated that experiments are limited in providing an assessment that is totally close to reality, and as such our experiments would need to be replicated in a real-world settings in these resource-constrained areas so that unforeseen challenges could also be noted and observed so that the model could also be improved.

8.7.2 Content Access Mechanism

The experimental evaluation of proposed BSDCM focused mainly on the network and web application components of technical architecture. Accessing other data-rich services such as video was not tested in the Thin Client computing and proxy server platforms. It is recommended that researchers should conduct further experiments to test if other various third-party content providers can create and deploy various educational services and content for different computing platforms.

8.7.3 ICT4ED Policies

Drawing from the literature and case study findings, it was noted that mobile devices are seen as a vital tool to facilitate teaching and learning in the classrooms. However, the majority of educators discourage the use of mobile devices in the classrooms citing theft and discipline among other reasons. To promote the use of ICTs by both learners and educators in the classrooms, it is highly recommended that policy makers introduce the policies governing the use of mobile devices in the classrooms.

8.8 Concluding Statements

This study focused on addressing the challenges faced by resource-constrained public high schools regarding lack of access to education content in electronic format. Furthermore, the study adopted Design Science Research (DSR) methodology to design and evaluate the proposed BSDCM that could potentially address these challenges. To promote the use of ICTs in the classroom, it is envisaged that more interventions would emerge with regard to policy guidelines governing the use of ICTs in public schools from all the stakeholders.

Chapter 6 of this study outlined the minimum requirements of BSDCM suitable for resource-constrained public schools. The proposed BSDCM was also developed, identifying the main components that provide the guidelines. The technical components derived from conceptual model were used to develop broadband service delivery technical architecture for implementation in the resource-constrained public high schools. In Chapter 7, the proposed BSDCM was evaluated using extensive simulations, visualisation tools and comparative analysis to evaluate the effectiveness of a proposed broadband service delivery conceptual model.

Findings from experimental evaluation has shown that compression of TCP/IP header over PPP Wide Area Network (WAN) link could potentially improve the response time to access web pages. This study will also inform other researchers about the nature of value adding services and content considered by high schools as relevant and useful. In addition, the findings will then inform the state of network access technologies in the rural areas.

Appendix A-Case Study Interview Schedule

SEMI-STRUCTURED INTERVIEW QUESTIONS

Toward a broadband services delivery model over wireless technologies to resource-constrained public high schools in South Africa

Dear Participant

Thank you for your willingness to participate in this research study.

- The interview forms part of my research currently undertaken in the Information Technology Department of Unisa towards fulfillment of my Master's degree.
- As a participant in this research study you will answer the questions voluntarily, and you can ask follow-up questions for clarity.
- You may not receive any direct benefit from my participation in this interview.
- Your participation is completely voluntary and that you may withdraw at any time from this research study.
- You may decline to answer any questions with which you feel uncomfortable.
- Your name and identity will not be used in reports or presentations of the findings of this research, i.e. anonymity will be preserved.
- Please note that this interview will be recorded and transcribed for reporting purposes.
- All your responses will remain anonymous, and no parts of your personal details will be revealed in the final report.

The semi-structured interview questions

1. How important is the use of Information and Communication Technologies (ICTs) by teachers and students in the school?
2. What ICTs does the school (i.e. teachers and learners) currently have access to?
3. What are these ICTs used for?
4. Do you currently have access to the Internet in the school, labs, or classes? If yes, what is it being used for?
5. **If YES to Question 4**, what type of Internet access do you have? Is it wired or wireless?
6. Does the school require teachers or learners to access teaching or learning information via the Internet or mobile networks (even if it is not during school time)?

7. **If YES to Question 6.** What challenges does the school currently experience regarding access to learning material (information and services) via the Internet or mobile networks?
8. What are the value-added services and content considered by school as relevant and useful for teaching and learning?
9. What is the perceived quality of the mobile networks (e.g. MTN, Vodacom, Cell C) around your school and area?
10. Are learners, currently allowed to use their mobile devices for educational purposes in class? If not, why?
11. What are the general ICT requirements (needs) by the school for better teaching and learning?
12. Any other comments?

Thank you for your valuable input and time. The results of this study could be shared with the participants through an executive summary report, complete research dissertation and/or conference papers.

Appendix B- Published Conference Paper

Pholotho, T. and Mtsweni, J., 2016. Barriers to electronic access and delivery of educational information in resource constrained public schools: A case of Greater Tubatse Municipality. In *IST-Africa Week Conference, 2016 (pp. 1-9), Durban, South Africa, 11-13 May 2016*. ISBN: 978-1-905824-54-0.

Appendix C- Ethical Clearance



Mr Tholo Johannes Pholotho (53338987)
College of Science, Engineering and Technology
UNISA
Johannesburg

2014-08-11

Permission to conduct research project

Ref: 156/TJP/2014

The request for ethical approval for your MTech (Information Technology) research project entitled "Toward a broadband services delivery model over wireless technologies to resource-constrained public high schools in South Africa" refers.

The College of Science, Engineering and Technology's (CSET) Research and Ethics Committee (CREC) has considered the relevant parts of the studies relating to the abovementioned research project and research methodology and is pleased to inform you that ethical clearance is granted for your study as set out in your proposal and application for ethical clearance.

Therefore, involved parties may also consider ethics approval as granted. However, the permission granted must not be misconstrued as constituting an instruction from the CSET Executive or the CSET CREC that sampled interviewees (if applicable) are compelled to take part in the research project. All interviewees retain their individual right to decide whether to participate or not.

We trust that the research will be undertaken in a manner that is respectful of the rights and integrity of those who volunteer to participate, as stipulated in the UNISA Research Ethics policy. The policy can be found at the following URL:

http://cm.unisa.ac.za/contents/departments/res_policies/docs/ResearchEthicsPolicy_apprvCounc_21Sept07.pdf

Please note that if you subsequently do a follow-up study that requires the use of a different research instrument, you will have to submit an addendum to this application, explaining the purpose of the follow-up study and attach the new instrument along with a comprehensive information document and consent form.

Yours sincerely

Prof Ernest Mnkandla

Chair: College of Science, Engineering and Technology Ethics Sub-Committee

University of South Africa
College of Science, Engineering and Technology
The Science Campus
C/o Christiaan de Wet Road and Pioneer Avenue,
Florida Park, Roodepoort
Private Bag X6, Florida, 1710
www.unisa.ac.za/cset



Appendix D- Letter of Permission to Conduct Research at GTM



LIMPOPO
PROVINCIAL GOVERNMENT
REPUBLIC OF SOUTH AFRICA

DEPARTMENT OF
EDUCATION
SEKHUKHUNE DISTRICT

Enq: Muthiba B.O
Tel: 015 633 2902
Date: 29/07/2014

To: Mr Tholo Johannes Pholotho (Masters Student: Information Technology)
School of Computing
University of South Africa

From: District Senior Manager
Sekhukhune District

SUBJECT: GRANTED PERMISSION TO CONDUCT RESEARCH.

1. The above matter refers.
2. Kindly be informed that your research application to conduct research in public high schools which is within The Greater Tubatse Municipality confines of Sekhukhune District, focusing on the title "*Toward a broadband services delivery model over wireless technologies to resource-constrained public schools in South Africa*", is approved.
3. Please note you should conduct your research in line with research ethics as prescribed by your institution and international norms and standards for research.
4. The district wishes you well in your research and awaits your findings with great interest.

NKADIMENG T.G.

DISTRICT SENIOR MANAGER

29.07.2014
DATE

Private Bag X70, Lebowakgomo, 0737
Parliamentary Building Tel: 015 633 7154/015 633 2800 Fax: 086 212 7513

Appendix E- Letter of Proof of Editing

Joan Hettema
250 Troye St
Muckleneuk
Pretoria 0002

Date: 18 February 2017

TO WHOM IT MAY CONCERN

This is to certify that I have duly edited a thesis in fulfilment of the requirements for a Masters – (*Magister Technologiae*) in Information Technology at the University of South Africa – ***Towards a Broadband Services Delivery Model over Wireless Technologies to Resource-Constrained Public High Schools in South Africa*** - by Tholo Johannes Pholotho.

I have a BA majoring in Latin and English from the University of Pretoria, Honours in English Language and Literature from Unisa and Troisième Degré in French from the Alliance Française. Throughout my 37-year fulltime career and the twenty years since, I have been involved with the process of writing English, editing English or lecturing in the field of Media Studies, English for Journalism and Business English at various tertiary institutions (Tshwane University of Technology, Boston College, Damelin College, Rosebank College and College Campus) as well as editing documents and theses for students at universities throughout the country. I have also served as a judge for the annual competition of the Publications Forum of South Africa for the past eight years.

Yours sincerely,

J A Hettema



Joan Ann Hettema (née Thies) 072-126-5174/ 012-440-4753

9 REFERENCES

- Abdelouahed, J. 2012. A Theoretical Prediction of Users in WCDMA Interference. *Journal of Theoretical and Applied Information Technology*, Vol. 35 No.2.
- Adikari, S., Mcdonald, C. and Campbell, J., 2009. Little design up-front: a design science approach to integrating usability into agile requirements engineering. In *International Conference on Human-Computer Interaction* (pp. 549-558). San Diego, California, USA, 19-24 July 2009.
- Adtran White Paper. n.d. Defining Broadband: Network Latency and Application Performance. Available from: <https://ecfsapi.fcc.gov/file/6520222942.pdf> [Accessed 20/01/2017].
- Agarwal, S. and De, S. 2016. Poster: Rural Broadband Access via TVWs. *Proceedings of the 14th Annual International Conference on Mobile Systems, Applications, and Services Companion*. Singapore, 25-30 June 2016.
- Al-Adwany, M.A., 2010. A performance study of wireless broadband access (WiMAX). In *Energy, Power and Control (EPC-IQ), 2010 1st International Conference on* (pp. 320-324). Sanya, China, 23-24 October 2010.
- Ali-Al-Mamun, M., Islam, M.M., Choe, S.-U. and Huh, E.-N. 2012. SCTP based protocol architecture for multihomed thin client. *Proceedings of the 6th International Conference on Ubiquitous Information Management and Communication - ICUIMC '12*. Kuala Lumpur, Malaysia, 20-22 February 2012.
- Alzain, A.M., Clark, S. and Ireson, G. 2014. Libyan Higher Education system, challenges and achievements. *ICEED 2014 - 2014 IEEE 6th Conference on Engineering Education*. 67–72. Kuala Lumpur, Malaysia, 9-10 December 2014.
- Anderson, R.E., Anderson, R.J., Borriello, G. and Kolko, B. 2012. Designing technology for resource-constrained environments: Three approaches to a multidisciplinary capstone sequence. *2012 Frontiers in Education Conference Proceedings*. 1–6. Seattle, WA, USA, 3-6 October 2012.
- Axelsson, H., Björkén, P., De Bruin, P., Eriksson, S. and Persson, H. 2006. GSM/EDGE continued evolution. *Ericsson Review (English Edition)*. 83(1):20–29.
- Bae, J., Kang, S., Kim, J. and Park, B.H. 2006. Next Generation Mobile Service Platform. In *Vehicular Technology Conference, 2006. VTC-2006 Fall. 2006 IEEE 64th* (pp. 1-5). Melbourne, Australia, 7-10 May 2006.
- Baladrón, C., Aguiar, J., Carro, B., Goix, L.W., Martín, A.L., Falcarin, P. and SieneI, J. 2009. User-centric future internet and telecommunication services. *Towards the Future Internet: A European Research Perspective*. 217–226.
- Bergaus, M. 2015. *Design Issues for Service Delivery Platforms: Incorporate User Experience: A Grounded Theory Study of Individual User Needs*. Springer: Leeds.
- Baxter, P., Susan Jack and Jack, S. 2008. Qualitative Case Study Methodology: Study Design and Implementation for Novice Researchers. *The Qualitative Report Volume*. 13(4):544–559.
- Bergaus, M. 2015. *Design Issues for Service Delivery Platforms: Incorporate User Experience: A Grounded Theory Study of Individual User Needs*. Springer.

- Bester, G. and Brand, L. 2013. The effect of technology on learner attention and achievement in the classroom. *South African Journal of Education*. 33(2):1–10.
- Bhattacharjee, A. 2012. *Social Science Research: Principles, Methods, and Practices*. Open Access Textbooks. Book 3: Florida.
- Bhushan, B., Tarlano, A., Fischer, G., Hendriks, J. and Arbanowski, S., 2007, January. Development and Publication of Generic Middleware Components for the Next Generation Mobile Service Platform. In *SAINT Workshops* (p. 7).
- Botha, A. and Herselman, M., 2013. Supporting rural teachers 21st century skills development through mobile technology use: A case in Cofimvaba, Eastern Cape, South Africa. In *Adaptive Science and Technology (ICAST), 2013 International Conference* (pp. 1-7). Pretoria, South Africa, 25-27 November 2013.
- Botha, A., Makitla, I., Tolmay, J.P. and Ford, M. 2010. Mobile4D Platform. In: *Cunningham, P. & Cunningham, M. (Eds), IST Africa 2010*, Durban, South Africa, 19-21 May 2010.
- Brittan, P., 2008. Evaluating Lossless Data Compression Algorithms for Use on Mobile Devices. *Literature Synthesis*.
- Broadband Commission, 2014. *The State of Broadband 2014: broadband for all*. Geneva, Switzerland. Available From: <http://www.broadbandcommission.org/documents/reports/bb-annualreport2014.pdf> [Accessed 14/11/2016].
- Cassell, C. and Symon, G. (Eds). 2004. *Essential Guide to Qualitative Methods in Organizational Research*. Sage Publications Ltd.
- Chen, H., Jin, H., Sun, J., Liao, X. and Deng, D. 2003. A new proxy caching scheme for parallel video servers. *Proceedings - 2003 International Conference on Computer Networks and Mobile Computing, ICCNMC 2003*. Shanghai, China, 20-23 October 2003.
- Chigona, A., Chigona, W. and Davids, Z. 2014. Educators' motivation on integration of ICTs into pedagogy: case of disadvantaged areas. *South African Journal of Education*, 34(3), pp.01-08.
- Chigona, A. and Chigona, W. 2013. South African pre-service teachers' under-preparedness to teach with Information Communication Technologies. *2013 2nd International Conference on E-Learning and E-Technologies in Education, ICEEE 2013*. 239–243. Lodz, Poland, 23-25 September 2013.
- Cho, J.H. and Lee, J.O., 2010. A deployment platform the SDP using enablers in presence service. In *Networked Computing and Advanced Information Management (NCM), 2010 Sixth International Conference* (pp. 381-384). Seoul, South Korea, 16-18 August 2010.
- Christian, R. and Hanrahan, H.E., 2007. Defining a service delivery platform architecture using generic ims and SOA concepts. In *11th International Conference on Intelligence in Service Delivery Networks (ICIN 2007)*. Bordeaux, France, 8-11 October 2007.
- Christian, R. and Hanrahan, H., 2008. Structuring the next generation network using a standards-based service delivery platform. In *Innovations in NGN: Future Network and Services, 2008. K-INGN 2008. First ITU-T Kaleidoscope Academic Conference* (pp. 33-40). Geneva, Switzerland, 12-13 May 2008.
- Condie, R. and Munro, B., 2007. The impact of ICT in schools: *Landscape review*.

- Cordier, C., Carrez, F., Van Kranenburg, H., Licciardi, C., Van der Meer, J., Spedalieri, A., Le Rouzic, J.P. and Zoric, J., 2006. Addressing the challenges of Beyond 3G service delivery: the SPICE service platform. In *Workshop on Applications and Services in Wireless Networks (ASWN'06)*. Silicon Valley, USA.
- Dalvit, L., Kromberg, S. and Miya, M., 2014. The Data Divide in a South African Rural Community: A Survey of Mobile Phone Use in Keiskammahoek. *3rd National South African e-Skills Summit*. Cape Town, South Africa, 17-21 November 2014.
- Demeter, H. (ed). 2008. Mobile Service Platforms – Architecture Whitepaper. (March):1–38. Available From: http://cordis.europa.eu/pub/ist/docs/ct/whitepaper1-service-architecture-final-spice_en.pdf. [Accessed 25/08/2015].
- Department of Basic Education. 2004. *White Paper on E-education*. Available on: <http://www.education.gov.za/LinkClick.aspx?fileticket=%2BfGxKN%2FCtg0%3D> [Accessed 22/01/2017].
- Department of Basic Education. 2011. Progress on the Implementation of the Regional Education and Training Plan (integrating the Second Decade of Education in Africa and Protocol on Education and Training) SADC and COMEDAF V May 2011. Available From: http://www.gov.za/sites/www.gov.za/files/DOBE_SADC-AU%20Draft%20Report_0.pdf. [Accessed 29/02/2016].
- Department of Basic Education. 2013. ABC of Introduction to Using Manuals: SASAMS. Available from: <http://www.sasams.co.za/sa-sams-manuals/dbe/pdf/IntroductionModule.pdf> [Accessed 03/12/2017]
- Department of Basic Education. 2016. Annual performance plan 2015 - 2016. Available: <http://www.education.gov.za/Portals/0/Documents/Reports/DBE%20APP%202015-16.pdf?ver=2015-03-20-153734-927> [Accessed 02/02/2017].
- Department of Communications. 2013. South Africa Connect:creating Opportunities,Ensuring Inclusion South Africa'd Broadband Policy. 3(37119):3–64. Available: www.gov.za/documents/download.php?f=205142 [Accessed 10/10/2016].
- Dhar, S. 1990. 51-20-06 The Use of Data Compression in Routed Internetworks. Available From: <http://www.ittoday.info/AIMS/DCM/51-20-06.PDF> [Accessed 25/02/2016].
- Dlodlo, N., 2009. Access to ICT education for girls and women in rural South Africa: A case study. *Technology in society*, 31(2), pp.168-175.
- Drago, Z., Visnja, K. and Kresimir, G., 2012. Business case assessments of fixed and mobile broadband access networks deployments. In *Software, Telecommunications and Computer Networks (SoftCOM), 2012 20th International Conference on* (pp. 1-5). Split, Croatia, 11-13 September 2012.
- Ebner, M., Kickmeier-Rust, M. and Holzinger, A. 2008. Utilizing Wiki-Systems in higher education classes: A chance for universal access? *Universal Access in the Information Society*. 7(4):199–207.
- EL-Dolil, S.A. and EL-Safrawey, A.S. 2007. Performance evaluation for integrated high altitude platforms-terrestrial General Packet Radio service system. In *Computer Engineering & Systems, 2007. ICCES'07. International Conference* (pp. 340-345). Cairo, Egypt, 27-29 November 2007.
- Eriksson, M., Furuskar, A., Johansson, M., Mazur, S., Molmo, J., Tidestav, C., Vedrine, A. and

Balachandran, K., 2000. The GSM/EDGE radio access network-GERAN; system overview and performance evaluation. In *Vehicular Technology Conference Proceedings, 2000. VTC 2000-Spring Tokyo. 2000 IEEE 51st* (Vol. 3, pp. 2305-2309). Tokyo, Japan, 15-18 May 2000.

Etemad, K., 2008. Overview of mobile WiMAX technology and evolution. *IEEE communications magazine*, 46(10).

Evoh, C.J. 2007. Policy networks and the transformation of secondary education through ICTs in Africa: The prospects and challenges of the NEPAD e-schools initiative. *International Journal of Education and Development using ICT*. 3(1):1–17.

Fedaghi, S. Al, Alsaqa, A. and Fadel, Z. 2009. Conceptual Model for Communication. *International Journal of Computer Science*. 6(2):13.

Femminella, M., Francescangeli, R., Giacinti, F., Maccherani, E., Parisi, A. and Reali, G., 2009. Scalability and performance evaluation of a JAIN SLEE-based platform for VoIP services. In *Teletraffic Congress, 2009. ITC 21 2009. 21st International* (pp. 1-8). Paris, France, 1–8 September 2009.

Fereday, J. and Muir-Cochrane, E. 2006. Demonstrating Rigor Using Thematic Analysis : A Hybrid Approach of Inductive and Deductive Coding and Theme Development. *International Journal of Qualitative Methods*. 5:80–92.

Filho, E.L., Hashimoto, G.T. and Rosa, P.F. 2008. An IMS Control and Access Layer PR-SCTP Based Network. *Fourth International Conference on Networking and Services (icns 2008)*. Gosier, Guadeloupe, 16-21 March 2008.

Ford, M. and Batchelor, J. 2007: From zero to hero – is the mobile phone a viable learning tool for Africa? In *3rd International Conference on Social and Organisational Informations and Cybernetics*, SOIC 2007, Orlando, USA, 19-20 March 2007.

Ford, M., Botha, A. and Herselman, M. 2014a. ICT4RED 12 Component Implementation Framework : A Conceptual Framework for Integrating Mobile Technology into Resource Constrained Rural Schools. *IST-Africa 2014 Conference Proceedings*. 1–11. Mauritius, 06-09 May 2014.

Gemino, A. and Wand, Y. 2004. A framework for empirical evaluation of conceptual modeling techniques. *Requirements Engineering*. 9(4):248–260.

Gillwald, A., Moyo, M. and Stork, C. 2012. What is happening in ICT in South Africa: A supply-and demand-side analysis of the ICT sector. *Evidence for ICT Policy Action*. (7).

Gondi, V.K. and Agoulmine, N. 2007. Secured Roaming Over WLAN and WIMAX Networks. *2007 2nd IEEE/IFIP International Workshop on Broadband Convergence Networks*. (pp:1–12). Munich, Germany, 21-21 May 2007.

GSMA Intelligence. 2015. The Mobile Economy Sub-Saharan Africa 2015. *GSMA Association*. 1–82. Available:
http://www.gsmamobileeconomyindia.com/GSMA_Mobile_Economy_India_Report_2013.pdf. Accessed [28/01/2017].

GSMA Intelligence. 2016. Global Mobile Trends. *GSMA Intelligence*. 1–82. Available:
<https://www.gsmaintelligence.com/research/?file=357f1541c77358e61787fac35259dc92&download>. Accessed [29/01/2017].

- GTM Annual Report. 2013. Final 2013/14 idp 1 |. Greater Tubatse Local Municipality. Available: http://www.tubatse.gov.za/docs/idp/GTM_FINAL_2013-14_IDP.pdf. [Accessed 19/11/2015].
- GTM Annual Report. 2015. Greater Tubatse Local Municipality Available from: <http://www.tubatse.gov.za/docs/reports/GTM+201415+Annual++Report.pdf>. [Accessed 28/09/2016].
- Halonen, T., Romero, J. and Melero, J. (eds)., 2004. *GSM, GPRS and EDGE performance: evolution towards 3G/UMTS*. John Wiley & Sons.
- He, G., 2001. Overview of UMTS. *Telecommunication Software and Multimedia Laboratory*, Helsinki University of Technology.
- Herselman, M.E., 2003. ICT in rural areas in South Africa: various case studies. *Informing Science Proceedings*, pp.945-955. Pori, Finland, 24 - 27 June 2003.
- Holma, H. and Toskala, A. (eds)., 2005. *WCDMA for UMTS: Radio access for third generation mobile communications*. John Wiley & sons.
- Herselman, M. and Botha, A., 2014. *Designing and implementing an Information Communication Technology for Rural Education Development (ICT4RED) initiative in a resource constraint environment: Confimvaba school district, Eastern Cape, South Africa*, 1ed. 2014 CSIR Meraka: Pretoria, South Africa.
- Hevner, R.H., March, S.T., Park, J. and Ram, S., 2004. Design science in information systems research. *MIS quarterly*, 28(1), pp.75-105
- Hevner, A.R., 2007. A three cycle view of design science research. *Scandinavian journal of information systems*, 19(2), p.4.
- Hevner, A.R., March, S.T. Park, J. and Ram, S., 2004. Design science in information systems research. *MIS quarterly*, 28(1), pp.75-105.
- Hove, S.E. and Anda, B. 2005. Experiences from conducting semi-structured interviews in empirical software engineering research. *Proceedings - International Software Metrics Symposium*. 2005(Metrics):203–212. Como, Italy .
- Huang, I., Guo, R., Xie, H. and Wu, Z., 2012. The convergence of information and communication technologies gains momentum. *The Global Information Technology Report*, pp.35-45.
- Iano, Y., T. Lima, I., J. Loschi, H., C. Lustosa, T., S. Mesquita, O. and Moretti, A. 2015. Sustainable Computing and Communications - Internet Broadband Network of Things Applied to Intelligent Education. *Proceedings of the 4th International Conference on Smart Cities and Green ICT Systems*. 350–356. Lisbon, Portugal.
- ITU. 2014. The Final WSIS Targets Review. Available: <http://www.itu.int/en/ITU-D/Statistics/Pages/publications/wsistargets2014.aspx>. [Accessed 23/07/2016].
- ITU and UNESCO. 2015. The State of Broadband 2015: Broadband as a Foundation for Sustainable Development. *United Nations Broadband Commission*. 100. Available from:

- <http://www.broadbandcommission.org/Documents/reports/bb-annualreport2015.pdf>. Accessed [05/10/2016].
- ITU and UNESCO. 2016. The State of Broadband 2016: Broadband For All. Available from: <http://unesdoc.unesco.org/images/0024/002459/245905e.pdf>. Accessed [01/02/2017].
- ITWEB. 2016. *Copper cable theft costs Telkom R200m* | ITWeb. Available: http://www.itweb.co.za/index.php?option=com_content&view=article&id=153104 [09/02/2017].
- Jacobson, V. 2015. Improving the Internet with ICN. *Proceedings of the 2nd International Conference on Information-Centric Networking - ICN '15*. 7–8. San Francisco, CA, USA.
- Johnson, D., 2007. Evaluation of a single radio rural mesh network in South Africa. In *Proceedings Information and Communication Technologies and Development, 2007*. ICTD 2007. *International Conference on* (pp. 1-9). Doha. Qatar.
- Jere, N.R., Thinyane, M., Boikhutso, T. and Ndlovu, N., 2013. An assessment of ICT challenges in rural areas: ICT experts vs rural users views: a case of the Siyakhula Living Lab. In *Proceedings of the South African Institute for Computer Scientists and Information Technologists Conference* (pp. 233-241). East London, South Africa, 07-09 October 2013.
- Johnston, A., Gabrielsson, J., Christopoulos, C., Huysmans, M. and Olsson, U. 2007. Evolution of service delivery platforms. *Ericsson Review (English Edition)*. 84:19–25.
- Kang, A.S. 2011. Pulse Shape Filtering in Wireless Communication-A Critical Analysis. 2(3):68–74.
- Khanya Project. n.d. Available from: <http://wced.school.za/branchCM/DEL/khanya.html>. [Accessed 22/01/2016]
- Kennedy, R., George, K., Vitalice, O. and Okello-Odongo, W. 2015. TV White Spaces in Africa Trials and Role in Improving Broadband Access in Africa. *Proceeding of the IEEE 12th 2015 AFRICON International Green Conference*. Addis Ababa, 14–17 September 2015.
- Khan, S. 2015. South Africa 's National Broadband Policy Purpose – SA Connect. Available From: https://www.researchictafrica.net/presentations/Presentations/2015%20Khan_Safia_ITU%20Broadband%20Policy%20Presentation.pdf. [Accessed 29/01/2017].
- Khumalo, B., Molepo, G. and Mji, A., 2015. Perceptions of school principals on the challenges arising from unavailability of information and communication technologies (ICT) in rural South African Schools. *Proceedings of the Rethinking Teaching and Learning in the 21st Century*. Manhattan Hotel Pretoria, South Africa, 21-23 September 2015.
- Kinyanjui, M., 2014. 'Kids on the tab': Kenya National Library Service's Tablet Computers Project for slum school children. Available From: <http://library.ifla.org/862/1/144-kinyanjui-en.pdf> [Accessed 10/06/2017].
- Koopman, M., 2014. Step-by-step approach: The integration of ICT in the classroom in rural African schools. In *eChallenges e-2014, 2014 Conference* (pp. 1-8). Belfast, Ireland, 29-30 October 2014.
- Labor, O., Mićin, M., Nižić, J. and Žunko, Z., 2010. The experience of using open source technologies for implementation of mobile Value Added Services. In *MIPRO, 2010 Proceedings of the 33rd International Convention* (pp. 572-576). Opatija, Croatia, 24-28 May 2010.

- Labuschagne, A. 2003. Qualitative research-airy fairy or fundamental. *The Qualitative Report*. 8(1):100–103.
- Leedy, P.D. and Ormrod, J.E. 2010. *Practical Research: Planning and Design, Ninth Edition*. New Jersey: Pearson Education.
- Li, R., Tao, Q. and Wang, Y., 2015. A qualitative comparative analysis (QCA) of innovation network attributes. In *Logistics, Informatics and Service Sciences (LISS), 2015 International Conference on (pp. 1-6)*. Barcelona, Spain, 27 - 29 Jul 2015.
- Liu, J., Zhang, W., Gao, W. and Yu, Y., 2012, May. Conceptual model for simulation and its verification & validation. In *Computer Science and Automation Engineering (CSAE), 2012 IEEE International Conference Vol. 3*, pp. 622-626). Zhangjiajie, China, 25 May 2012.
- Liu, X., Ma, Y., Liu, Y., Xie, T. and Huang, G., 2016. Demystifying the imperfect client-side cache performance of mobile web browsing. *IEEE Transactions on Mobile Computing*, 15(9), pp.2206-2220.
- Louw, R. and Dörflinger, J., 2010. Further lessons from the Sekhukhune Rural Living Lab-Mobile web business applications in emerging economies. In *IST-Africa, 2010* (pp. 1-10). Lilongwe, Malawi, 19-21 May 2010.
- Lu, H., Zheng, Y. and Sun, Y., 2008. The next generation SDP architecture: Based on SOA and integrated with IMS. In *Intelligent Information Technology Application, 2008. IITA'08. Second International Symposium (Vol. 3, pp. 141-145)*. Shanghai, China, 21-22 December 2008.
- Ma, W.H. and Du, D.H.C., 2002. Reducing bandwidth requirement for delivering video over wide area networks with proxy server. *IEEE Transactions on Multimedia*, 4(4), pp.539-550.
- MacDonald, A., Cartas, R. and Incera, J., 2011. Custom tailored location based services: An IMS implementation. In *Telecommunications (ICT), 2011 18th International Conference on* (pp. 118-123). Ayia Napa, Cyprus, 8-11 May 2011.
- Maes, S.H. 2007. Service delivery platforms as IT realization of OMA service environment: Service oriented architectures for telecommunications. *IEEE Wireless Communications and Networking Conference, WCNC*. 2885–2890. Hong Kong, China.
- Magedanz, T. and Gouveia, F.C., 2006. IMS—the IP multimedia system as NGN service delivery platform. *e & i Elektrotechnik und Informationstechnik*, 123(7), pp.271-276.
- Makitla I. and Fogwill T. 2011. Mobi4D: Mobile Value-Adding Service Delivery Platform. In: Park J., Arabnia H., Chang HB., Shon T. (eds) *IT Convergence and Services. Lecture Notes in Electrical Engineering*, vol 107. Springer, Dordrecht.
- Maras, J., Stula, M., Carlson, J. and Crnkovic, I. 2013. Identifying code of individual features in client-side web applications. *IEEE Transactions on Software Engineering*. 39(12):1680–1697.
- Masonta, M.T., Olwal, T. and Ntlatlapa, N., 2010. An Energy Saving Scheme for Internet Provision in Rural Africa: LESS. In *IST-Africa, 2010* (pp. 1-7). Lilongwe, Malawi, 19-21 May 2010.
- Mathevula, M.D. and Uwizeyimana, D.E. 2014. The Challenges Facing the Integration of ICT in Teaching and Learning Activities in South African Rural Secondary Schools. *Mediterranean Journal of Social Sciences*. 5(20):1087–1097.
- Mdlongwa, T. 2012. Information and Communication Technology (ICT) as a Means of

- Enhancing Education in Schools in South Africa : Challenges, Benefits and Recommendations. (80):1–8. Available From: <http://www.ai.org.za/wp-content/uploads/downloads/2012/10/No.-80.-ICTas-a-means-of-enhancing-Education-in-Schools-in-South-Africa.pdf>. [Accessed 17/10/2015].
- Mekuria, F., 2011. Enabling wireless broadband technologies and services for the next billion users. In *AFRICON, 2011 (pp. 1-6)*. Livingstone, Zambia, 13-15 September 2011.
- Mestry, R. and Ndhlovu, R. 2014. The implications of the National Norms and Standards for School Funding policy on equity in South African public schools. *South African Journal of Education*. 34(3):1–11.
- Metsälä, E. and Salmelin, J. 2012. *Mobile Backhaul*. John Wiley & Sons.
- Michael, R. and Shimba, F. 2012. A critical performance analysis of Thin Client platforms. In *2nd International Conference on Digital Information and Communication Technology and its Applications, DICTAP 2012*. 383–387. Bangkok, Thailand, 16-18 May 2012.
- Microsoft Partners in Learning | Creating Opportunities*. n.d. Available: <https://www.microsoft.com/southafrica/partnersinlearning/> [Accessed 10/11/2016].
- Mikre, F. 2011. The Roles of Information Communication Technologies in Education Review Article with Emphasis to the Computer and Internet. 6(2).
- Mishra, P. and Koehler, M.J. 2006. Technological pedagogical content knowledge: A framework for teacher knowledge. *Teachers College Record*. 108(6):1017–1054.
- Mkhomazi, S.S. and Iyamu, T. 2011. The social context of broadband infrastructure sharing. *Proceedings of the 13th International Conference on Information Integration and Web-based Applications and Services - iiWAS '11*. 403. Ho Chi Minh City, Vietnam, 5-7 December 2011.
- Mlitwa, N. and Ockards, M., 2008. Towards a Viable Broadband Solution in South Africa: the Potential of WiMAX Technology. In *IST-Africa 2008 Conference Proceedings Paul Cunningham and Miriam Cunningham (Eds) IIMC International Information Management Corporation. 2008 (pp. 1-11)*. Windhoek, Namibia, 07 - 09 May 2008.
- Mlitwa, N. 2012 (ed). *IT/ICT Research & Innovations: A Socio-technical Approach*. Cape Town:TVK eNNOVATIONS.
- Motsi, L. and Kalema, B.M. 2015. Knowledge Sharing Framework for Educators in Southern Africa : A Case Study of Secondary Schools in Tshwane South District. 1–10. In *ISTAfrica 2015*. Lilongwe, Malawi, 05 -08 May 2015.
- Moriana Group. n.d. General SDP. Available: <http://www.morianagroup.com/index.php/january-2015/8-service-delivery-platform-definition>. [Accessed 21/01/2016].
- Muller, F., Sorelius, J. and Turina, D., 2001. Further evolution of the GSM/EDGE radio access network. *Ericsson Rev (ENGL ED)*, 78(3), pp.116-123.
- Muriithi, G.M. and Masinde, M., 2016. Cloud SAMS: Cloud computing solution for public schools within South Africa's 'second economy'. In *IST-Africa Week Conference, 2016 (pp. 1-15)*. Durban, South Africa, 11-13 May 2016.
- National Planning Commission. 2010. National Development Plan (2030). Available: <http://www.gov.za/sites/www.gov.za/files/Executive%20Summary-NDP%202030%20-%20Our%20future%20-%20make%20it%20work.pdf> [Accessed: 25/08/2015].
- Ndlovu, N., Thinyane, M. and Terzoli, A., 2009. Deployment and Extension of a Converged

- WiMAX/WiFi Network for Dwesa Community Area South Africa. In *Southern African Telecommunication Networks and Applications Conference*. Sugar Beach Resort, Mauritius. 9-13 September 2007.
- Neuman, L.W. 2011. *Social research methods: Qualitative and quantitative approaches* (7th Edition). Boston: Pearson Publishing.
- Ngyende, A. 2012. Statistical release (Revised) Census 2011. Available: <https://www.statssa.gov.za/publications/P03014/P030142011.pdf> [Accessed 28/05/2015].
- Niess, M.L., 2005. Preparing teachers to teach science and mathematics with technology: Developing a technology pedagogical content knowledge. *Teaching and teacher education*, 21(5), pp.509-523.
- Nkula, K. and Krauss, K.E., 2014. The integration of ICTs in marginalized schools in South Africa: Considerations for understanding the perceptions of in-service teachers and the role of training. In *8th annual International Development Informatics Association Conference*. Port Elizabeth, South Africa, 3- 4 November, 2014.
- Nyathi, O., Terzoli, A. and Tsietsi, M. 2013. Unicorn: A unified communication solution for marginalized communities. *2013 International Conference on Adaptive Science and Technology*. Pretoria, South Africa, 25-27 November 2013.
- O'Connell, J., 2007. Service delivery within an IMS environment. *IEEE Vehicular Technology Magazine*, 2(1), pp.12-19.
- Odhiambo, M.O., Amimo-Rayolla, P.O. and Kurien, A.M., 2009. Towards a converged network: Video streaming over WiMAX vs. HSDPA in the rural environment. In *AFRICON, 2009. AFRICON'09*. (pp. 1-6). Nairobi, Kenya, 23-25 September 2009.
- Ogunleye, O.S., Makitla, I., Botha, A., Tomay, J.P., Fogwill, T., Seetharam, D. and Geldenhuys, P., 2011. Mobi4D: A next generation service delivery platform for mobile government services: An African perspective. In *Adaptive Science and Technology (ICAST), 2011 3rd IEEE International Conference* (pp. 15-20). Abuja, Nigeria, 24-26 November 2011.
- Onwuegbuzie, A.J. and Leech, N.L. 2007. Sampling Designs in Qualitative Research : Making the Sampling Process More Public. *The Qualitative Report*. 12(2):19–20.
- Olivier, M.S., 2009. *Information Technology Research A practical guide for computer Science and Informatics (Third.)*. Hatfield. Pretoria: Van Schaik Publishers.
- Pande, M. and Patel, N., 2012. Regional study of telecom technology options for Indian rural education: with special reference to Vidarbha region, Maharashtra, India. In *Proceedings of the CUBE International Information Technology Conference (pp. 180-185)*. Pune, India, 03 - 06 September 2012.
- Park, J.J., Arabnia, H., Chang, H.B. and Shon, T., 2014. *IT Convergence and Services: ITCS & IRoA 2011-Volume 108*.
- Pickvance, C. 2005. The four varieties of comparative analysis: the case of environmental regulation. *Paper for Conference on Small and large-N comparative solutions*. University of Sussex, 22–23 September 2005.
- Pilkington, C. and Pretorius, L. 2015. A Conceptual Model of the Research Methodology Domain, With a Focus on Computing Fields of Study. *7th International Joint Conference on*

- Knowledge Discovery, Knowledge Engineering and Knowledge Management (IC3K 2015)*. 2(Ic3k):96–107. Lisbon, Portugal, 12-14 November 2015.
- Pitman, M. and Ventura, N., 2009, October. The use of resource list servers in IMS presence for developing networks. In *Ultra-Modern Telecommunications & Workshops, 2009. ICUMT'09. International Conference* (pp. 1-7). Petersburg, Russia, 12-14 Oct. 2009.
- Proctor, T.K., 2003. Evolution to 3G services: provision of 3G services over GERAN (GSM/EDGE radio access network). (1):78–82.
- Rebahi, Y., Sher, M. and Magedanz, T., 2008. Detecting flooding attacks against IP Multimedia Subsystem (IMS) networks. In *Computer Systems and Applications, 2008. AICCSA 2008. IEEE/ACS International Conference* (pp. 848-851). Doha, Qatar, 31 Mar - 04 Apr 2008.
- Roberts, S., Garnett, P. and Chandra, R. 2015. Connecting Africa using the TV white spaces: From research to real world deployments. *IEEE Workshop on Local and Metropolitan Area Networks*. Beijing, China, 22-24 April 2015.
- RSA. 2016. Republic of South Africa Tablings and Committee Reports. (10):234–323. Available from: http://www.parliament.gov.za/live/commonrepository/Processed/20161122/616390_1.pdf. [Accessed 20/01/2016].
- Ryan, G.W. and Bernard, H.R. 2003. Techniques to Identify Themes. *Field Methods*. 15(1):85–109.
- Sagar, S. and Gothawal, D.B. 2014. NTHC: A nested tunnel header compression mechanism for tunneling over IP. *2014 International Conference for Convergence of Technology, I2CT 2014*. 1–6. Pune, India, 6-8 April 2014.
- Sanchez, A., Carro, B. and Wesner, S. 2008. Telco services for end customers: European Perspective. *IEEE Communications Magazine*. 46(2):14–18.
- SA News. n.d. *Operation Phakisa ICT to take education to new standard* Available: <http://www.sanews.gov.za/south-africa/operation-phakisa-ict-take-education-new-standard> [22/12/2015].
- SA News. 2016. Tablets to be withdrawn from Gauteng schools .Available: <http://www.sanews.gov.za/south-africa/tablets-be-withdrawn-gauteng-schools> [14/02/2016]
- SchoolNet SA Annual Report. 2015. Capacity 2015. Available From: <http://www.schoolnet.org.za/wp-content/uploads/CAPABILITY-2015.pdf> [Accessed 20/01/2017].
- SchoolNet SA. n.d. Available From: <http://www.schoolnet.org.za/>. [Accessed 21/11/2016].
- Section 27. 2014. The Limpopo Textbook Crisis in South Africa:1–5. Available from: http://www.right-to-education.org/sites/right-to-education.org/files/resource-attachments/RTE_Success_Story_Limpopo_2014_en%20_0.pdf. [11/02/2016].
- Sharma, S.U. and Gandole, Y.B. 2014. Virtualization approach to reduce network latency for thin client performance optimization in cloud computing environment. *2014 International Conference on Computer Communication and Informatics: Ushering in Technologies of Tomorrow, Today, ICCCI 2014*. 1–6. Coimbatore, India, 03 May 2014.
- Sher, M. and Magedanz, T., 2007. Protecting IP multimedia subsystem (IMS) service delivery platform from time independent attacks. In *Information Assurance and Security, 2007. IAS 2007*.

Third International Symposium on (pp. 171-176). Manchester, United Kingdom. 29-31 August 2007.

Sherman, K. & Howard, S.K. (2012). Teachers' Beliefs about First- and Second-Order Barriers to ICT Integration: Preliminary Findings from a South African Study. In P. Resta (Ed.), *Proceedings of Society for Information Technology & Teacher Education International Conference 2012* (pp. 2098-2105). Austin, Texas, 5th - 9th March 2012.

Slabbert, J.A. and Buys, A.J., 2007. Technology roadmap process to compare commercial broadband technologies available to SME and SOHO owners in South Africa. In *AFRICON 2007* (pp. 1-9). Windhoek, Namibia, 26 - 28 Sep 2007.

Sibanda, K., Muyingi, H.N. and Mabanza, N., 2008. Building wireless community networks with 802.16 standard. In *Broadband Communications, Information Technology & Biomedical Applications, 2008 Third International Conference on* (pp. 384-388). Pretoria, South Africa, 23rd - 26th November 2008.

Sienel, J., Martín, A.L., Zorita, C.B., Goix, L.W., Reol, Á.M. and Martínez, B.C., 2009. OPUCE: A telco-driven service mash-up approach. *Bell Labs Technical Journal*, 14(1), pp.203-218.

Song, S. 2016. Unlocking Affordable Access in Sub-Saharan Africa. (43). Available From: <https://www.cigionline.org/sites/default/files/documents/GCIG%20no.43.pdf> [Accessed 10/06/2017].

Spieß, J., Joens, Y.T., Dragnea, R. & Spencer, P. 2014. Using Big Data to Improve Customer Experience and Business Performance. *Bell Labs Technical Journal*. 18(4):3-17.

Statistics SA. 2015. Statistical release, P0318: General Household Survey: 2015. Available From: <https://www.statssa.gov.za/publications/P0318/P03182015.pdf> [Accessed 14 January 2017].

Tarkoma, S., Prehofer, C., Zhdanova, A.V., Moessner, K. and Kovacs, E., 2007. SPICE: Evolving IMS to next generation service platforms. In *Applications and the Internet Workshops, 2007. SAINT Workshops 2007. International Symposium on* (pp. 6-6). Hiroshima, Japan, 15-19 January 2007.

Taylor-Powell, E. and Steele, S., 1996. Collecting evaluation data: Direct observation. *Program Development and Evaluation. Wisconsin: University of Wisconsin-Extension*, pp.1-7.

TECH4RED. n.d. Available from: <http://www.ict4red.co.za/about-us/tech4red/>. [Accessed 19/01/2017].

Telkom SA Annual Report. 2011. Abridged Integrated Annual Report. Available From: http://www.telkom.co.za/ir/apps_static/ir/pdf/financial/pdf/TelkomAR_2011_Abridged.pdf [Accessed 15/02/2016].

Telkom SA Report, 2014. Telkom SA Group Annual Report. Available From: http://www.telkom.co.za/ir/apps_static/ir/pdf/financial/pdf/Annual_telkom_2014.pdf [Accessed 26/02/2016].

Telkom SA Report, 2015. Telkom SA Integrated Report. Available From: http://www.telkom.co.za/ir/apps_static/ir/pdf/financial/pdf/Telkom%20IR%202015%20Final.PDF. [Accessed 26/02/2016].

Vodacom SA, n.d. Available from: <http://www.vodacom.co.za/vodacom/coverage-map>.

Accessed [29/01/2017].

Von Alan, R.H., March, S.T., Park, J. and Ram, S., 2004. Design science in information systems research. *MIS quarterly*, 28(1), pp.75-105.

Walaza, M., Looock, M. and Kritzinger, E., 2014. A framework to integrate ICT security awareness into the South African schooling system. In *Proceedings of the Southern African Institute for Computer Scientist and Information Technologists Annual Conference 2014 on SAICSIT 2014 Empowered by Technology* (p. 11). Centurion, South Africa, September 29 - October 01, 2014.

Wandre, S., 2000. *EDGE: Enhanced Data Rates for GSM Evolution*. Available From: <https://pdfs.semanticscholar.org/ed8d/ebf42510b010b399610c5bea306237b3b71c.pdf> [Accessed 22/07/2015].

Wang, L. and Manner, J. 2009. Evaluation of data compression for energy-aware communication in mobile networks. *2009 International Conference on Cyber-Enabled Distributed Computing and Knowledge Discovery*. 69–76. Nanjing, China, 10-12 Oct 2009.

Wang, H., Shi, X., Li, Y., Chang, H., Chen, W., Tang, J. and Martins, E. 2008. User profile management for personalized telecom service. *Proceedings of the 9th International Conference for Young Computer Scientists, ICYCS 2008*. Zhang Jia Jie, China, 18 - 21 Nov 2008.

Wang, R., Bonasu, S. and Bagasrawala, S., 2004. The impact of TCP-IP header compression on performance over satellite links. In *Wireless Communications and Networking Conference, 2004. WCNC. 2004 IEEE* (Vol. 4, pp. 2021-2026). Atlanta, GA, USA, 21-25 March 2004.

Holma, H. and Toskala, A. eds., 2005. *WCDMA for UMTS: Radio access for third generation mobile communications*. John Wiley & sons.

Wille, V. and Kok, M. 2006. *Performance of data services in GERAN networks ELECTRONICS LETTERS 5th January 2006*. 42(1):1–2.

Xiao, Y., Siekkinen, M. & Ylä-Jääski, A. 2010. Framework for energy-aware lossless compression in mobile services: The case of e-mail. *IEEE International Conference on Communications*. Tamil Nadu, India, 07-09 Oct 2010.

Yin, R.K. 1993. Case study methods. *Handbook of complementary methods in education research*. 111–122.

Yin, R.K. 2009. *Case Study Research: Design and Methods*. V. 5. L. Bickman & D.J. Rog, Eds. Sage Publications.

Yu, J., Falcarin, P., Del Álamo, J.M., Sienel, J., Sheng, Q.Z. and Mejia, J.F. 2009. A user-centric mobile service creation approach converging telco and IT services. *2009 8th International Conference on Mobile Business*. Cambridge, United Kingdom, 22-25 November 2009.

Zhang, Q.Y. and Chu, Q.X., 2009. Triple-band dual rectangular ring printed monopole antenna for WLAN/WiMAX applications. *Microwave and Optical Technology Letters*, 51(12), pp.2845-2848.