

**Elimination of systematic faults and maintenance uncertainties on the City of  
Johannesburg's roads Intelligent Transport Systems**

by

PHALANNDWA LAWRENCE MAKHWATHANA

submitted in accordance with the requirements  
for the degree of

MAGISTER TECHNOLOGIAE

in the subject of

ELECTRICAL ENGINEERING

at the

UNIVERSITY OF SOUTH AFRICA

SUPERVISOR: PROF S. DU

FEBRUARY 2016

# Declaration

Student number: 47309075

I declare that Elimination of systematic faults and maintenance uncertainties on the City of Johannesburg's roads Intelligent Transport Systems is my own work and that all the sources that I have used or quoted have been indicated and acknowledged by means of complete references. This dissertation is being submitted for the degree of Master of Technology at the University of South Africa, Pretoria. It has not been submitted before for any degree or examination at any other university.

---

SIGNATURE

---

DATE

Mr Phalanndwa Lawrence Makhwathana

## Acknowledgement

I would like to acknowledge my supervisor, Professor S. Du, for understanding my passion in Intelligent Transport Systems (ITS) and for guiding me to the final stage of this dissertation. I am glad to have had you as my mentor.

I would like to thank my employer, Johannesburg Roads Agency (JRA) for supporting me with the time and resources necessary to accomplish this research. I may not mention all the names of Transport Engineers and Technologists, ITS project implementation and maintenance technical staff, with whom I have always interacted throughout the research, but their inputs are highly appreciated.

To my beloved family, your belief in me and moral support kept me passionate.

God, glory be to thee.

## Publications derived from this dissertation

1. Phalanndwa L. Makhwathana and Shengzhi Du. “Analysis on Faults and Maintenance Uncertainties at Traffic Signal Junctions in the City of Johannesburg”. 4<sup>th</sup> International Conference in traffic and Transportation Engineering 2015 (ICTTE 2015)
2. Phalanndwa L. Makhwathana and Shengzhi Du. “Road ITS Backup Power Source Performance Estimation”. 4<sup>th</sup> International Conference in traffic and Transportation Engineering 2015 (ICTTE 2015)

## Abstract

Road transport mobility continues to be a challenge to the City of Johannesburg (CoJ)'s economy in general. Traffic signals, their remote monitoring and control systems are the current implemented Intelligent Transport Systems (ITS), but daily systematic faults and maintenance uncertainties on such systems decrease the effectiveness of traffic engineers' intersections optimization techniques.

Inefficient electrical power supply to such ITS is a challenge, with conditional power cuts and fluctuations, uncertainties on traffic control system faults. Another factor leading to the problem is the communication channel which is using traditional modems which are not reliable. Reporting through both customer complaints and such unreliable remote monitoring systems makes maintenance to be ineffective.

In this dissertation, the factors leading to the faults and uncertainties are considered. The proposed solution considers the important concerns of ITS, such as electrical power source performance optimization technique, road traffic control systems compatibility and communications systems. Energy consumption and battery bank state of charge (SOC) are modelled and used to determine the running period prediction with reference to traffic signal control timing plan. Research results and analysis on proposed model show that its implementation shall improve mobility in the CoJ.

## Key terms

- Intelligent Transport Systems
- Uninterruptable Power Supply
- Battery Runtime
- Load Prediction
- Fuzzy Logic Systems
- Artificial Neural Networks
- Packet Switching

# Table of Contents

Declaration.....	i
Acknowledgement .....	ii
Publications derived from this dissertation .....	iii
Abstract .....	iv
Key terms.....	v
Table of Contents .....	vi
List of figures.....	viii
List of tables .....	x
List of abbreviations.....	xi
Delimitations.....	xiii
1. Introduction .....	1
1.1 Background.....	1
1.2 Research problem.....	3
1.3 Objectives of the research .....	3
1.4 Value of the research.....	4
1.5 Research methodology .....	4
1.6 Structure of dissertation sections .....	5
2. Review of related literature .....	6
2.1 Introduction .....	6
2.2 Artificial Intelligence Techniques .....	6
2.3 Traffic Signal Control .....	9
2.4 Electrical Power Supply and Stability .....	15
2.5 Power Supply Performance Prediction .....	23
2.6 Communication Networks and Synchronization .....	25
2.7 Systems Reliability .....	28
3. Analysis of the current situation on ITS faults and maintenance uncertainties in the City of Johannesburg .....	30
3.1 Introduction .....	30
3.2 Faults Analysis.....	35
3.3 Maintenance uncertainties .....	44
4. Proposed solution, modeling and configuration of energy efficient roads ITS.....	45

4.1	Introduction of the proposed solution .....	45
4.2	Energy storage efficiency optimization .....	48
4.3	Road ITS Electrical Power Source Performance Estimation Technique .....	50
4.4	TCU and LED Lights Compatibility.....	56
4.5	Remote Monitoring Network.....	57
4.6	Conclusion.....	59
5.	Implementation and analysis of energy efficient roads ITS.....	60
5.1	Introduction .....	60
5.2	Information collection.....	60
5.3	Battery SOC and Runtime Estimation .....	65
5.4	Communication network.....	68
5.5	Road network reliability assessment.....	69
5.6	Results analysis.....	79
6.	Conclusions and Future research .....	81
6.1	Conclusion.....	81
6.2	Future research.....	81
	List of references.....	83
	Appendix A: Wi-Fi scanned frequencies .....	90



## List of figures

Figure 1: Fuzzy Logic application on Matlab.....	7
Figure 2: Matlab extracted neural networks structure.....	8
Figure 3: Example of ANFIS structure. ....	9
Figure 4: SARTSM example of signal interval. ....	10
Figure 5: Time-space diagrams.....	12
Figure 6: Semi-actuated control in American layout. ....	14
Figure 7: Fully-actuated control in South African layout. ....	14
Figure 8: Possible distortion in input voltage .....	16
Figure 9: UPS types .....	17
Figure 10: Power supply system schematics. ....	19
Figure 11: MPPT operation. ....	21
Figure 12: Ring-feed electrical power distribution network schematic. ....	22
Figure 13: Packet switching. ....	26
Figure 14: SCADA block diagram.....	28
Figure 15: Reliability function.....	28
Figure 16: CoJ metropolitan municipality map .....	30
Figure 17: Junction with 2-way 4-lane street. ....	31
Figure 18: Junction with 2-way 7-lane street. ....	31
Figure 19: Junction with 2-way 5-lane streets and right-turn lane. ....	32
Figure 20: Junction with 2-way 5-lane streets and right-turn lane. ....	32
Figure 21: Consecutive junctions of different layouts. ....	33
Figure 22: Current road ITS architecture. ....	33
Figure 23: Recorded traffic signal faults analysis.....	40
Figure 24: Daily average traffic signal faults occurrence analysis. ....	40
Figure 25: Monthly faults analysis .....	41
Figure 26: UPSs discharge characteristics. ....	43
Figure 27: Standard conversion concepts.....	46
Figure 28: Multiple-battery configuration.....	49
Figure 29: Integrated road ITS connected properties.....	51
Figure 30: Battery performance or runtime estimation algorithm. ....	52
Figure 31: Basic battery measurement setup.....	54

Figure 32: Basic biased switching circuitry. ....	57
Figure 33: Communication network architectures.....	58
Figure 34: Sample junction layout.....	61
Figure 35: Stage movements plan.....	61
Figure 36: AM & PM fixed timing plan.....	62
Figure 37: Off-peak fixed timing plan. ....	63
Figure 38: Remaining 64.82Ah runtime.....	67
Figure 39: CoJ applicable Wi-Fi setup block diagram.....	68
Figure 40: A map showing Booyens road and its selected junctions .....	70
Figure 41: Booyens road traffic flow .....	71
Figure 42: Wi-Fi with 1-3ms response time .....	73
Figure 43: Wi-Fi with 5-10ms response time .....	74
Figure 44: Wi-Fi with 6-7ms response time .....	75
Figure 45: Wi-Fi with 12-40ms response time .....	76
Figure 46: GPRS with 559-1449ms response time.....	77
Figure 47: GPRS with 525 - 1673ms response time .....	78

## List of tables

Table I: Information on JRA's traffic signal backup and alternative power supply systems .....	34
Table II: Traffic control and communication components.....	35
Table III: September 2013 traffic signal faults data .....	38
Table IV: AM & PM peak cycle timetable .....	62
Table V: Off-peak cycle timetable.....	63
Table VI: Traffic control cycle weight data comparison .....	64
Table VII: 48V battery data.....	65
Table VIII: Battery charge cycle data .....	65
Table IX: ITS component assessment on SCADA .....	69
Table X: Booyens road network junctions data .....	70

## List of abbreviations

3G	=	Third Generation
AC	=	Alternating Current
Ah	=	Amp-hour
ANFIS	=	Adaptive Neuro Fuzzy Inference System
ANN	=	Artificial Neural Networks
ATMS	=	Advanced Traffic Management Systems
BRT	=	Bus Rapid Transit
BTS	=	Base Transceiver Station
CBD	=	Central Business District
CCTV	=	Closed Circuit Television
CoJ	=	City of Johannesburg
DC	=	Direct Current
DUSC	=	Dial Up Strategic Control
EDGE	=	Enhanced Data rates for GSM Evolution
ESKOM	=	Electricity Supply Commission
EU	=	European Union
GPRS	=	General Packet Radio Service
GSM	=	Global System for Mobile
IP	=	Internet Protocol
ISP	=	Internet Service Provider
ITS	=	Intelligent Transport Systems
ITSSA	=	Intelligent Transport Systems South Africa
JRA	=	Johannesburg Roads Agency
JMPD	=	Johannesburg Metropolitan Police Department
LED	=	Light Emitting Diode
MCU	=	Mobile Control Unit
MPPT	=	Maximum Power Point Tracking
MTU	=	Master Terminal Unit
NTCIP	=	National Transportation Communications for ITS Protocol
OCV	=	Open Circuit Voltage
PV	=	Photovoltaic

QoS	=	Quality of Service
RMS	=	Remote Monitoring System
RTU	=	Remote Terminal Unit
SANS	=	South African National Standards
SARTSM	=	South African Road Traffic Signs Manual
SCADA	=	Supervisory Control and Data Acquisition
SCOOT	=	Split Cycle Offset Optimisation Technique
SDA	=	Service Delivery Agreement
SMS	=	Short Message Service
SOC	=	State-of-Charge
SOD	=	State of Discharge
TCP	=	Transmission Control Protocol
TCU	=	Traffic Control Unit
TMC	=	Traffic Monitoring Centre
UPS	=	Uninterruptable Power Supply
UTC	=	Urban Traffic Control
VA	=	Vehicle Actuated
VICC	=	Voltage Inference Coulomb Counting
WAN	=	Wide Area Network
Wh	=	Watt-hour

## Delimitations

- This dissertation may serve to guide in development of DC LED lights and traffic control unit (TCU), but not the complete design.
- Implementation of external surge protection systems is not part of this dissertation.
- Software development is also not the purpose of this research, but guideline.

# 1. Introduction

## 1.1 Background

Road Traffic congestion is a serious problem to the economy. In the City of Johannesburg (CoJ) municipality, one of Johannesburg Roads Agency (JRA)'s service areas is the traffic regulatory infrastructure, with traffic signaling as a concern. JRA is responsible for over 2000 signalized intersections, while new other installations are taking place at other intersections of concern. They are located along 10 000km total length of roads.

Due to economic development, it is very important that efficient Intelligent Transport Systems (ITS) must be implemented in places like CoJ. According to City of Johannesburg, through technology installed (Split Cycle Offset Optimization Technique (SCOOT) / Urban Traffic Control (UTC)) at the company's mobility centre, the section can monitor traffic signals at various locations.

According to JRA's ITS technical section, it is through Advanced Traffic Management System (ATMS) / Supervisory Control and Data Acquisition (SCADA) as part from ITS / UTC, that traffic signals are monitored for any defects including systematic faults that have negative impact on traffic mobility. The company's Traffic Management Centre (TMC) also takes calls from the public, reporting any traffic signals defects, including such systematic faults. When technicians and electricians in the traffic signals maintenance department are given such faults information to fix, such maintenance attendance is expected to be done according to the customer charter standard, set by the CoJ municipality.

According to Traffic management & Network Support section of Mobility & Freight unit, one of the business units of JRA, working on ITS, in the year 2008, uninterruptable power supply (UPS) and solar systems were installed at identified intersections. This was as a result of high energy supply demand in the municipality and other parts of the country, leading to load shedding strategy initiated by power utility companies to deal with demand and supply challenges. JRA, the entity of CoJ, gets power supply for ITS, from Electricity Supply Commission (ESKOM), South Africa's main grid utility company or City Power, CoJ's entity for electricity, depending on area or region. However, according to Pieterse *et al.*

(2013), City Power is the largest electricity distribution company in the CoJ metropolitan area.

Load shedding was causing a lot of traffic congestion on CoJ roads. Energy Systems implemented are to store energy for such difficult time.

It was also decided that light emitting diode (LED) traffic signal lights had to be installed at every intersection as a way of retrofitting, to save on the supplied energy.

Different RMS components and configurations are used for ITS, depending on traffic control unit (TCU). Such ITS components are confirmed to be conforming to National Transportation Communications for ITS Protocol (NTCIP) standards. Implemented SCADA systems also use global system for mobile (GSM) for remote monitoring system (RMS), mobile control unit (MCU) and dial-up strategic control (DUSC).

JRA is facing the challenges of systematic faults and uncertainties in maintaining such faults reported by the public and current installed RMS. This also causes a serious delay against the maintenance turnaround times, set in the customer charter of the municipality. The occurrence of such faults and the delay to fix them, due to uncertainties within maintenance department, leaves a bad reflection of traffic signals status, resulting in traffic congestion.

Implementation of Rea Vaya bus rapid transit (BRT) has also added pressure, with dedicated lanes.

200 critical signalized intersections were identified by both JRA and Johannesburg Metropolitan Police Department (JMPD) as the busiest and with the most complaints record. According to Traffic Engineering section of Mobility & Freight unit, traffic impact studies have also been used to identify the busiest intersections. JMPD's selection is based on the intersections at which traffic officers have often been operating to reduce congestion due to systematic faults. JMPD gets callouts from JRA's TMC, about faulty traffic signals and traffic congested intersections. TMC gets calls from the public and some intersections with RMS. Such 200 intersections were common in both JRA and JMPD identification processes.



## 1.2 Research problem

City of Johannesburg's ITS systematic faults occurrence and maintenance uncertainties result in long-lasting roads traffic congestions in the City of Johannesburg.

Improvement of the current ITS, should look into the following sub-problems:

- Eskom's or City Power's grid power instability has negative impact on traffic signal control systems. The grid power supply fluctuates all the time.
- Current backup systems are not reliable in terms of actual capacity against off-grid time and variable loads. The charge level information cannot be used to predict autonomy. This involves both standard UPS and those with solar as primary source of energy.
- During traffic signal phase transition, the TCU turns the signals into flashing mode.
- Current communication network connectivity and speed are not reliable to ITS, with current SCADA systems' operational principle making it worse to use RMS.

## 1.3 Objectives of the research

- Analysis on the causes of identified systematic faults and maintenance uncertainty on installed ITS in the CoJ.
- Analysis on energy inefficiency of current road ITS in the CoJ. This should consider types of UPS and ESKOM or City Power's electric power distribution at traffic signal junctions.
- To compare circuit switching and packet switching efficiencies and recommend suitable communication model for ITS.
- To design energy efficient integrated ITS configuration model that aims to increase systems reliability, while eliminating double energy conversion by making use of clean regulated DC power distribution and operation, at an intersection.

- The research shall produce papers for publications.

#### 1.4 Value of the research

- There will be more certainty on reactive maintenance of ITS faults.
- Occurrence of systematic faults will be reduced by ensuring continuous direct current (DC) power supply and distribution for energy efficient ITS operations.
- Implementation of model of this research shall lead to the amendments of South African Road Traffic Signs Manual (SARTSM), for compliance.
- The research outcomes can be used by ITSSA members, including JRA as a guide to future energy efficient integrated ITS configuration model.
- Application of the model will intensify road transport mobility.

#### 1.5 Research methodology

- Random systematic faults analysis on CoJ's 200 critical and other intersections has been done.
- Assessment of installed energy efficient ITS infrastructure has been done, using collected data on power fluctuations and backup systems performance. Current ITS model and specifications have been analysed and improved model is proposed. This involve intersections with different backup power systems.
- Assessment of circuit-switched and packet-switched communication technology network. Synchronisation performance on SCADA systems has been done. Fault identification delay and operational principle of SCADA systems has been analysed in comparison with same faults reported by the public including possible positions or addresses when reporting such faults.

- Load estimation and performance prediction has been performed. Power backup capacity measurement method, Traffic signals timing plans per selected intersection and Artificial intelligent techniques have been used.
- Traffic engineering and Electrical/Electronic sections of traffic signals division, in JRA, will be consulted.

## 1.6 Structure of dissertation sections

Section 2 gives a review of related literature. As the sub-problems are outlined, there are probably different researches and methods with solutions, of related challenges. This section focuses on Traffic signal control, power supply, communication networks and artificial intelligence techniques.

Section 3 gives the analysis about the problem. It gives the analysis on the causes of the systematic faults and maintenance uncertainties.

Section 4 focuses on the proposed solution, modeling and configuration of road energy efficient traffic control systems. Different and suitable methods are implemented for different parts of the proposed solution. An integrated model is then introduced.

Section 5 shows how the introduced model is implemented based on selected scenarios. It also gives analysis of the implementation results in comparison with the existing road ITS.

Section 6 gives the conclusion and recommendations with reference to all the sections of this dissertation. It shows the level of satisfactions towards the objectives of the research. Related future research work is also suggested.

As always stated, where applicable, some work has been done by other researchers and documented for further activities. Section 7 gives the list of references from which some applicable ideas have been noted.

## 2. Review of related literature

### 2.1 Introduction

According to Wikipedia, though Intelligent Transport Systems (ITS) may not contain very high intelligence, they are advanced applications used in transport and traffic management of different modes, for smart, safer and more coordinated transport networks with well-informed users.

Although ITS may refer to all modes of transport, EU Directive 2010/40/EU of 07 July 2010 on the framework for ITS deployment in the field of road transport and for interfaces with other transport modes, defines ITS as systems in which information and communication technologies are applied in road transport field, including infrastructure, vehicles and users, and in traffic and mobility management, as well as for interfaces with other transport modes.

EDGEICT states that Interest in ITS comes from the problem caused by traffic congestion and a synergy of new information technology for simulation, real-time control and communication networks. Traffic congestion has been increasing worldwide as a result of increased motorization, urbanization, population growth and changes in population density. Congestion reduces efficiency of transportation infrastructure and increases travel time, air pollution and fuel consumption.

Of course, the development of ITS is also based on artificial intelligence, with relevance to principles of transportation engineering. To have such ITS operating, a source of stable electrical energy is important.

This research focuses more on roads ITS in relation to what CoJ, through the JRA implements. A review on related literature is presented.

### 2.2 Artificial Intelligence Techniques

Artificial intelligent techniques (AI) are relied on in different disciplines which contribute in resolving complicated problems in ITS. Fuzzy Logic and Neural Network systems are used.

## 2.2.1 Fuzzy Logic Systems

Fuzzy logic systems are highly considered in resolving uncertainty problems. Researchers in traffic engineering related problems also tend to implement such systems to improve road traffic mobility through optimization of traffic signals. Others like Feng *et al.* (2013) still continue in recent researches, to use fuzzy logic to estimate the state of charge of lead acid batteries. Fuzzy logic is also applicable in short-term load forecasting.

Wang (2005:202) defines fuzzy logic as a logic that attempts to combine the imprecision associated with natural events with the computational power of the computer to produce highly intelligent, robust and flexible reasoning systems. In other words, uncertainties require some intelligent power to bring about assurance in solving non-linear problems.

Negnevitsky (2011:87) describes fuzzy logic as the theory of fuzzy sets that calibrate vagueness. He further defines fuzzy set as a set with boundaries. To support this definition with relevance to identified problems in road ITS and specifications of current traffic control systems, fuzzy inference system application can be suitable in the grid power voltage of 220Vac +/- 5% and battery voltage measurements in percentage, from 0 to 100. Therefore, the basic control, protection and voltage stability systems can also be aligned to such principles to avoid confusion. Figure 1 below shows the basic application structure of fuzzy logic system, on Matlab.

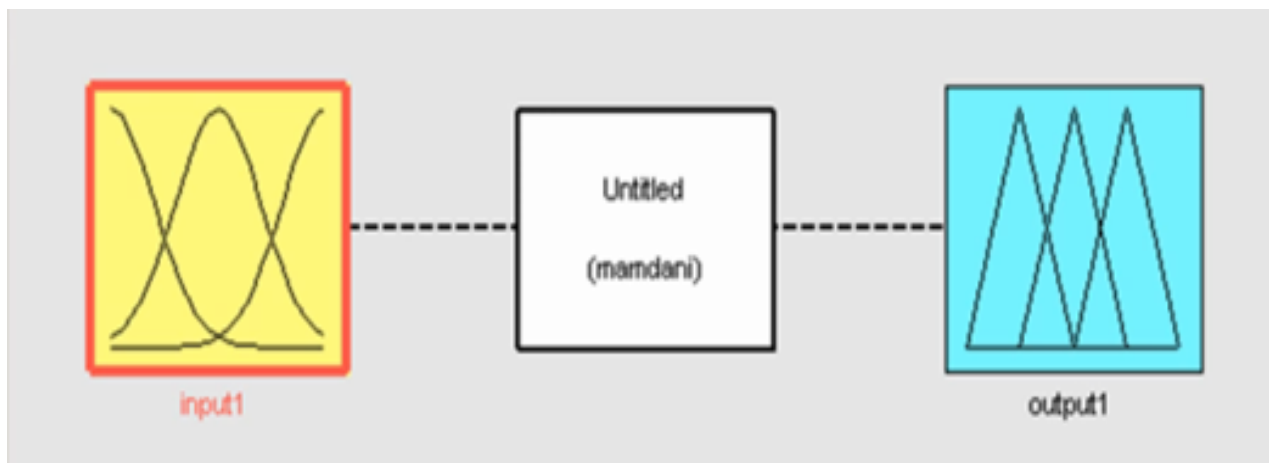

Figure 1: Fuzzy Logic application on Matlab.

### 2.2.2 Neural Network System

Like fuzzy logic, neural network (NN) is used to resolve nonlinearity of complex systems. The advantage of NN is the learning capability as stated by Abe (1997:4). NN learning can be attached to assessment of different measurements towards correlated and intended results. Ismail and Hassan (2013) used artificial neural network techniques to estimate state of charge for rechargeable batteries.

Figure 2 below is an example of Matlab extracted structure of neural network.

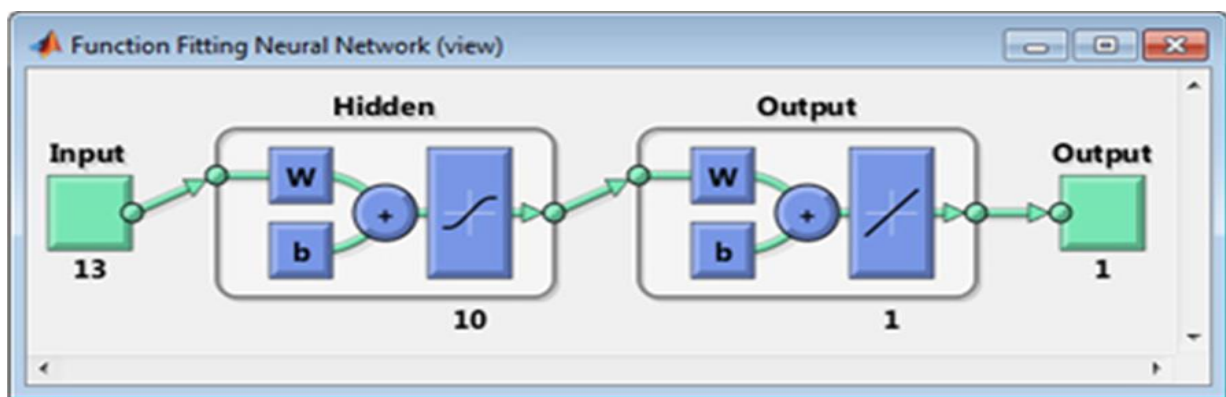

Figure 2: Matlab extracted neural networks structure.

### 2.2.3 Neuro-Fuzzy System (NFS)

This is a combination of fuzzy logic and neural network systems. It can be regarded as a hybrid system as it handles both learning and uncertainty problems. Researchers like Cai *et al.* (2003) have used this adaptive method to estimate battery state of charge. It is also relevant in assessment of the ITS power supply and stability.

Like neural networks, NFS involves training, as shown by Shen *et al.* (2002). It is further stated that ANN cannot provide heuristic knowledge of the battery on the SOC process. Fuzzy logic is said to be able to provide heuristic knowledge, but with difficulties in providing exact solution. Therefore, the combination of the ANN and fuzzy logic creates a comprehensive system with integrated features. The most common method of NFS is the

adaptive neuro fuzzy inference system (ANFIS). Figure 3 show an example of the ANFIS structure.

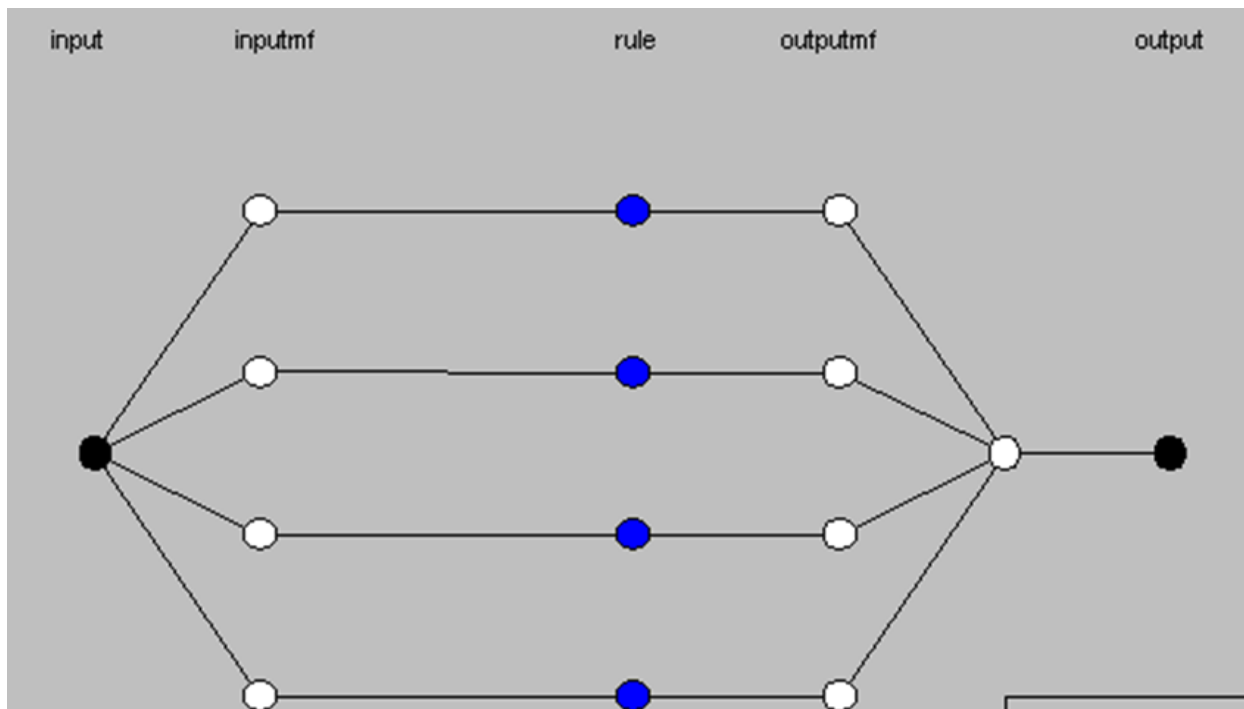

Figure 3: Example of ANFIS structure.

### 2.3 Traffic Signal Control

Traffic signal control is one of the intersection optimisation techniques in road traffic engineering. According to Davey and Thomas (2000), the first South African traffic signal was installed in Johannesburg. Detailed signal network description and comprehensive traffic flow data is required from the engineer, for traffic signal installation. Number of plans, best cycle times, offset and green splits are decided from analysis. Some coordination of traffic signals is needed to improve traffic flow. The following are the traffic signal control modes as stated in South African Road Traffic Sign Manual (SARTSM):

- Fixed timing control
- Vehicle-actuated control
- Traffic-responsive control

Fixed timing and vehicle-actuated modes of control are the commonly implemented in the CoJ. Such modes are determined by the timing plan, which also determines cycle time,

phases and stages sequence. The timing plans are morning (AM), midday (OFF) and evening (PM) peak timing plans. Figure 4 is an example of signal intervals for three-stage traffic signal with six signal groups, as shown in SARTSM (2001). The signal groups represent the movement of vehicles and pedestrians at a traffic signal junction.

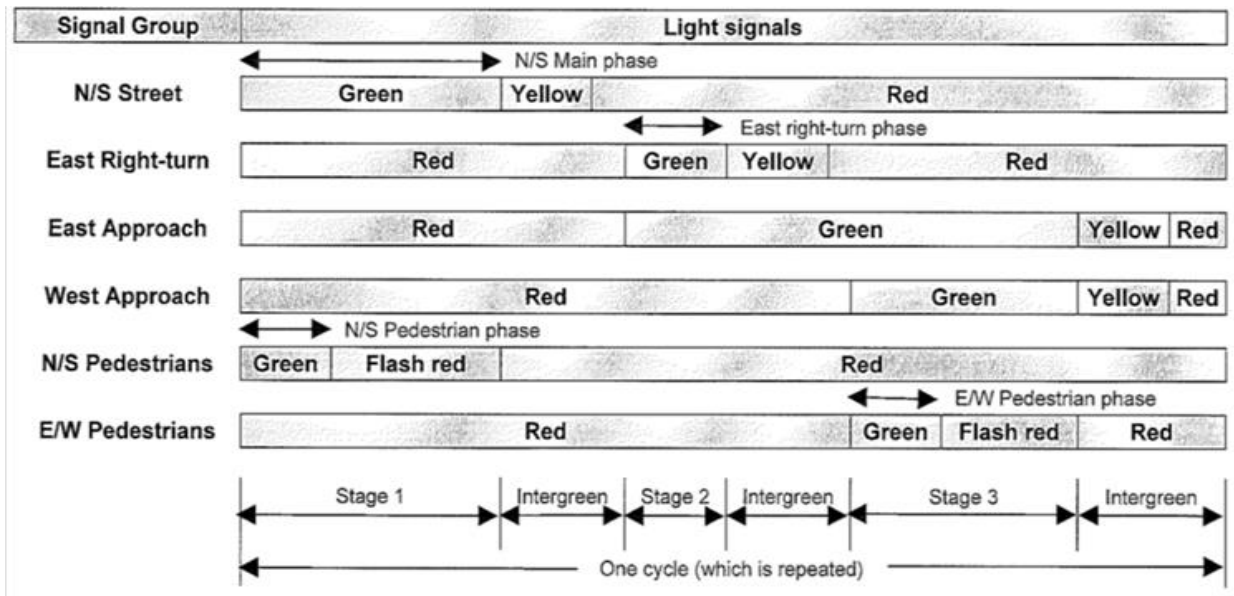

Figure 4: SARTSM example of signal interval.

### 2.3.1 Fixed timing control

As explained by Askerzade and Mahmood, (2010), fixed time control is calculated in advance. SARTSM, (2001), also adds that the control sequence and duration of each phase is the same in each cycle. In this mode, multiple timing plans are required to cope with the variation in traffic demand throughout the day. The cycle lengths may also be different per plan. Cycle length can be defined as the duration a full sequence of traffic signal lights in their colours, in which all approaches are satisfied.

### 2.3.2 Traffic signal coordination

The coordination between relative traffic signals is very important for mobility in urban areas. According to SARTSM (2001), coordinated systems are suitably applicable with fixed time signal. Goliya and Jain (2012) stated that a major objective of traffic signal synchronization at intersection is to clear maximum number of vehicles through the



intersection in a given length and time with least number of accidents, at maximum safe speed with minimum delay.

According to the City of Irvine, traffic signal synchronization is a traffic engineering technique of matching the green light times for a series of intersections to enable the maximum number of vehicles to pass through, thereby reducing stops and delays experienced by motorists. It should be noted, though, that this requires clocks of TCUs of such intersections to be at the same time. Time-space diagram is used to illustrate the concept of synchronization and expected system reliability in traffic engineering perspective, as shown on Figure 5.

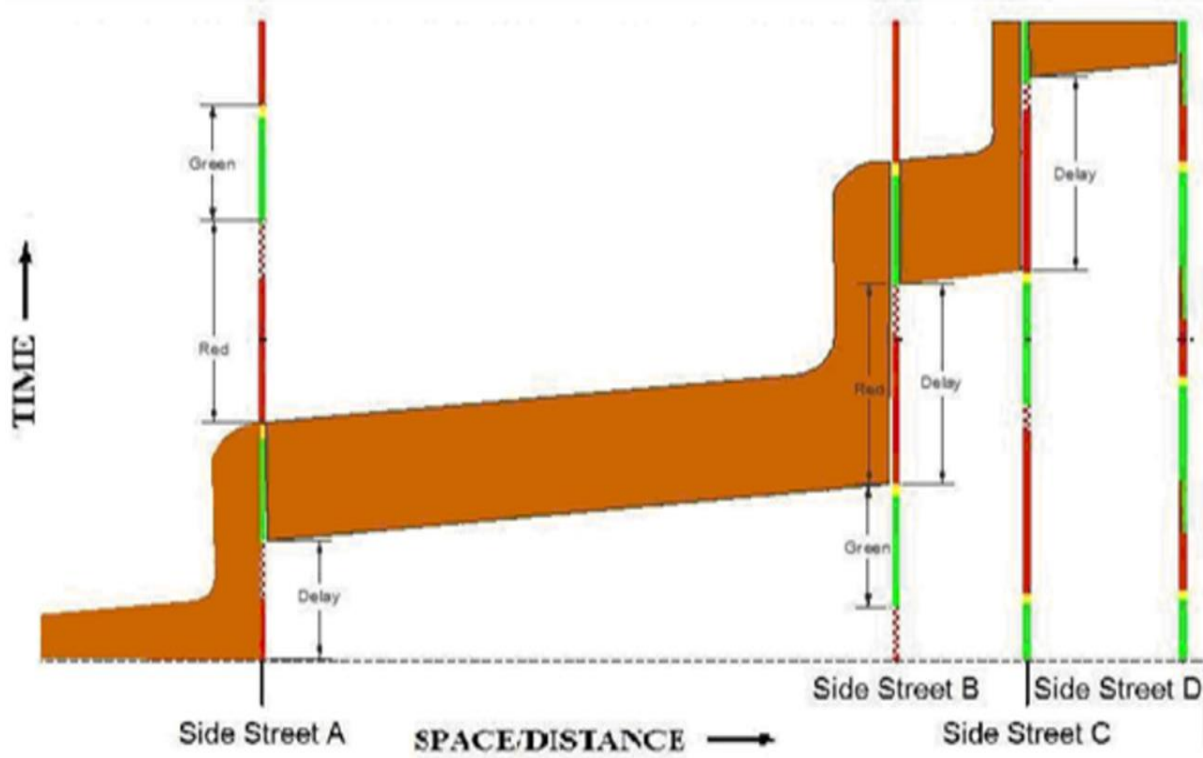

(a) Main street with unsynchronized traffic signals

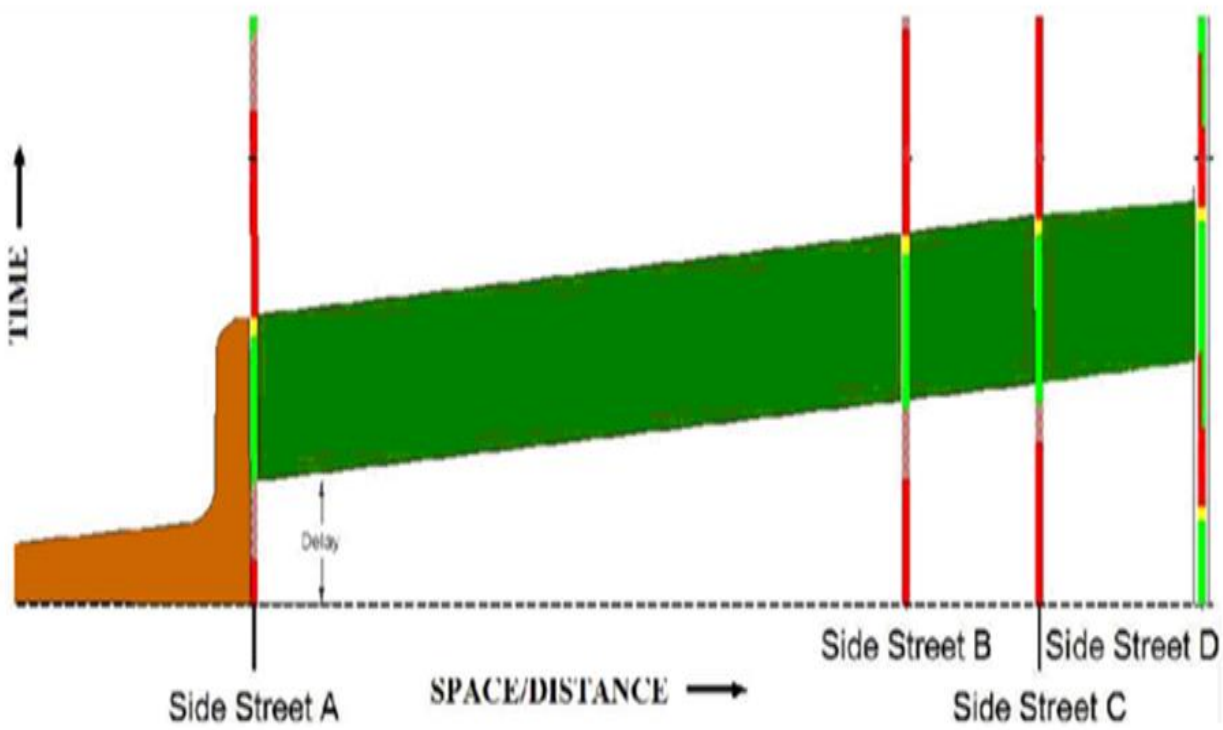

(b) Main street with synchronized traffic signals

Figure 5: Time-space diagrams

The yellow colour in Figure 5(a), represents slow vehicle traffic flow that results in congestion and causing vehicles to stop at every traffic signal junction. Green colour in Figure 5(b), represent a smooth flow of vehicle traffic progressing through well-coordinated and functional traffic signal junctions.

### 2.3.3 Vehicle-actuated (VA) control

This kind of control is also used in the CoJ, like in any other parts of the country and world in general. This control type has the capability to respond to the presence of vehicles at a junction. The presence of a vehicle is detected by electrical or electronic detectors. The most common VA control modes are semi-actuated and fully-actuated.

#### 2.3.3.1 Semi-actuated control

Semi-actuated control is used with detectors on minor street that intersects with the major street. The operation is similar to the real-time strategy defined by Askerzade and Mahmood (2010), as it combines preset cycle time with proximity sensors which can activate a change in the cycle time. As stated by Mathew (2014), the green light is on the major street at all times unless a call on the side street is noted. The active operation of detectors is in accordance with the validated peak timing plan.

Traffic signal junctions with such type of control are often implemented along all types of routes, as shown on Figure 6. Therefore, it is implemented on all categories of junctions, as explained in section 2 of this dissertation. Other junctions may have the turning arrow leading towards the side street.

Figure 6 shows an example of junction layout with semi-actuated control configuration, as presented by Mathew (2014).

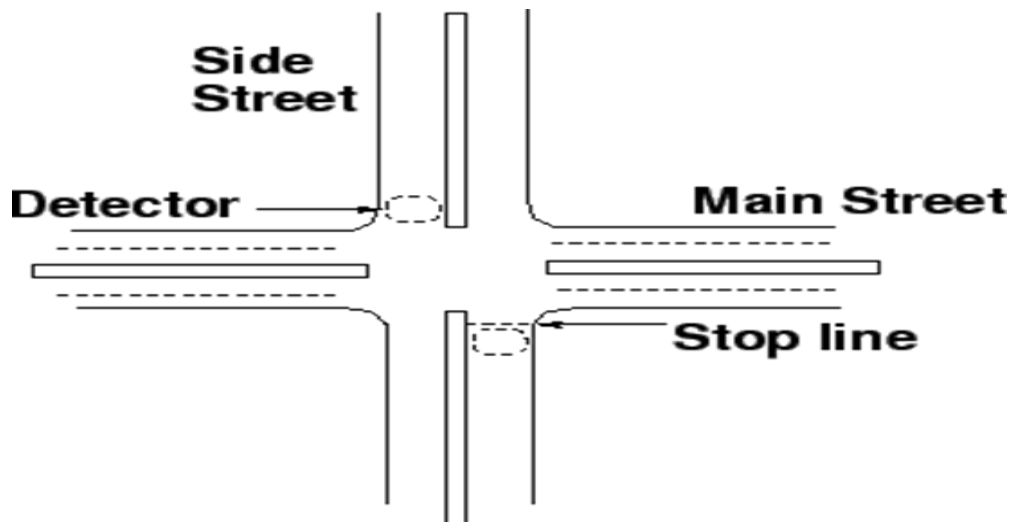

Figure 6: Semi-actuated control in American layout.

### 2.3.3.2 Fully-actuated control

This type of control mode needs detectors implemented on all approaches to a junction. It allows for the extension of all green intervals provided at a signal, especially on isolated junctions. Messer and Nageswara (1996) further explain that the junction at which such mode is applicable often has relatively equal volumes with varying traffic distribution. Figure 7 is an example of fully-actuated control junction layout, also presented by Mathew (2014).

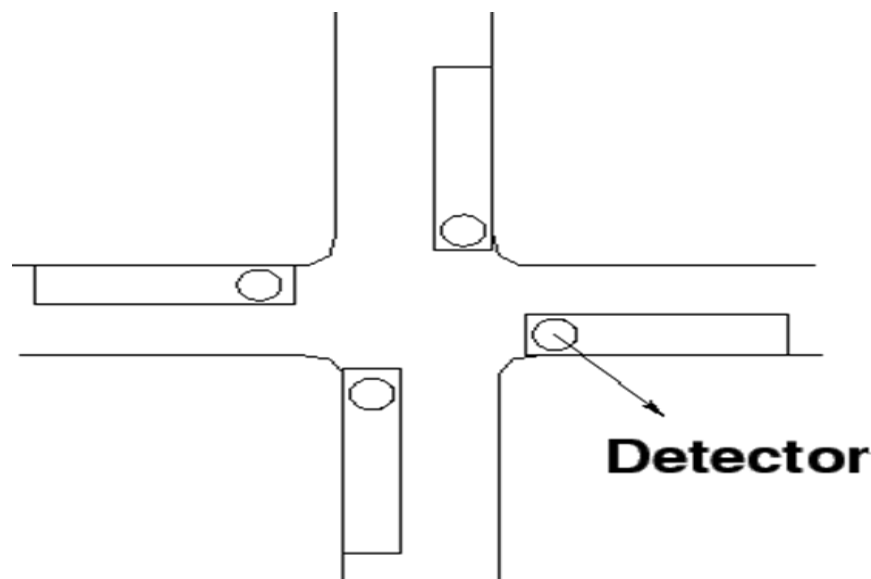

Figure 7: Fully-actuated control in South African layout.

## 2.4 Electrical Power Supply and Stability

Intelligent transportation systems operations depend on the supply of electrical power. The supply source can be standalone solar system or utility grid, which is the case in the City of Johannesburg.

### 2.4.1 Grid Power Supply

South African utility power supply network supplies alternating current (AC) power. Current traffic signals equipment is designed to operate on 220Vac at 50Hz +/- 5%. The grid network does encounter some disturbances which eventually have an effect on the load. According to Mohan et al. (2003:354-355), the following are the power-line disturbances:

- Overvoltage
- Under-voltage
- Outage
- Voltage spikes
- Chopped voltage waveform
- Harmonics
- Electromagnetic interference

Glover and Sarma (2002:589) further elaborate on lightning surges, switching surges and power frequency overvoltage as the types of overvoltage encountered by the power systems equipment. It is also the case in the city of Johannesburg, causing many traffic signals to be on red light flashing mode. Figure 8 shows possible distortion in input voltage.

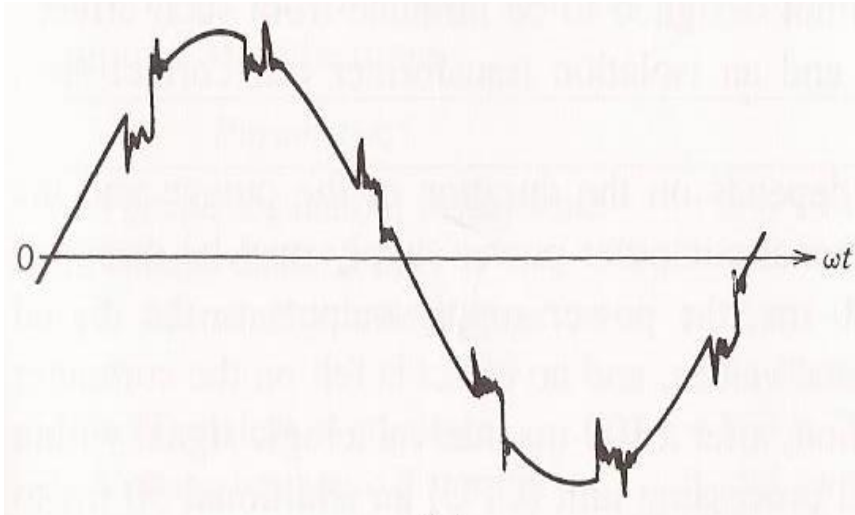

(a) Noise distortion

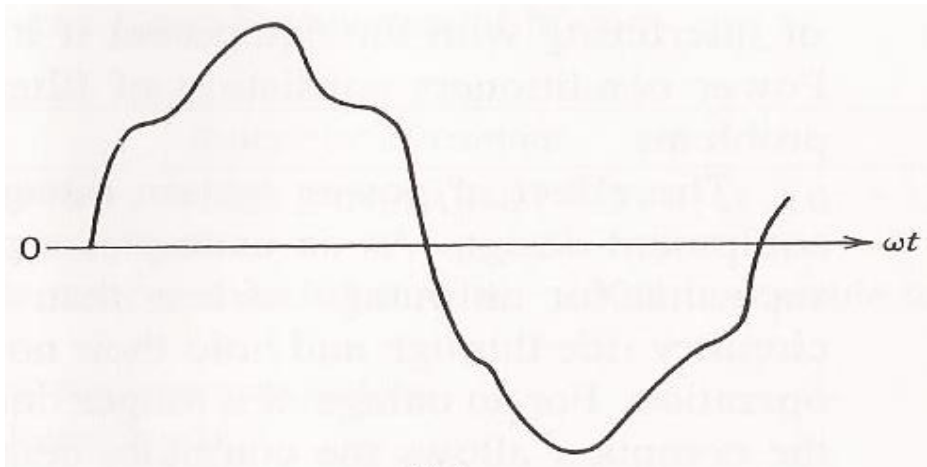

(b) Harmonic distortion

Figure 8: Possible distortion in input voltage

#### 2.4.2 Uninterruptable Power Supply (UPS) system

Commonly used UPS types are double conversion, line-interactive and standby. Gunes *et al.* (2009), state that, UPS systems are employed to supply the critical loads with continuous and energy of high quality, in facilities. The three types of UPS differ in their ability to perform critical functions and vary in the degree of security and level of power protection they provide. A UPS is composed of the following major components:

- Rectifier/charger
- Battery bank
- Inverter

UPS can be grid-connected, PV panel-connected or hybrid-connected. A charger converts either AC or DC to DC energy to be stored into the battery bank as well as supplying to the inverter. Batteries play an important part in storing energy for backup supply. Lead-acid batteries are the most used at traffic signal junctions in the CoJ.

Figure 9 shows the schematic designs of three types of commonly used UPSs, as demonstrated by Arias *et al.* (2012).

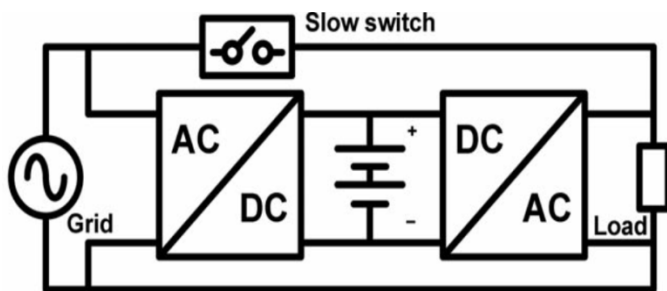

(a) Passive standby

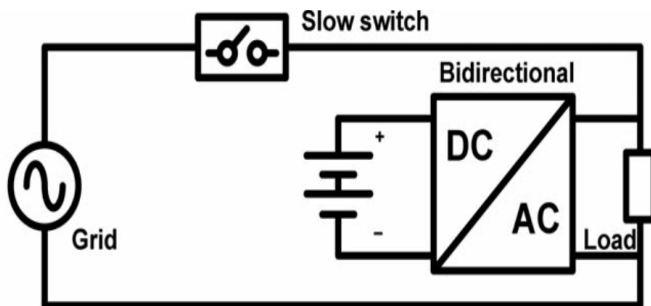

(b) Line-interactive

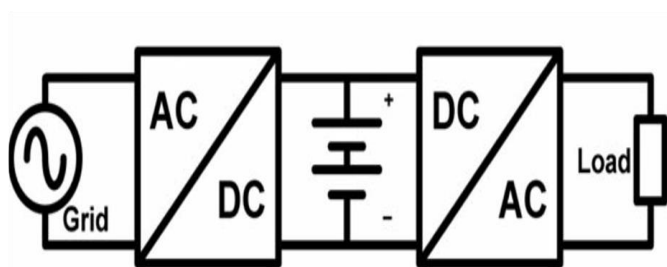

(c) Double-conversion

Figure 9: UPS types

As explained by Rathmann and Warner (1996), the inverter supplies the load with continuous, precisely regulated AC power. Arias *et al.* (2008) add that the difference between UPSs in Figure 9 is the way in which the elements are connected to the load and the grid. It can be deduced that the conversion of energy in grid connected UPS to the load connection point, is done twice, from AC to DC and CD to AC.

### 2.4.3 Solar Power Supply System

Solar system is used to harness natural energy from the sun. This is a renewable energy supply system applicable for traffic signals and other parts of ITS. Kalingamudali *et al.* (2006) also motivated that the use of solar cells with lead acid accumulators to provide required power and use of light emitting diode (LED) displays to function as signal lamps to reduce the stored power consumption will be a feasible solution.

Current implemented solar systems supply power to AC LED lights and traffic signal controllers. The system consists of solar panels, battery charger, battery bank and DC/AC inverter. Due to sizes of such systems, they cannot be implemented at every junction, especially within the city. Qiao *et al.* (2011) also presented a hybrid power supply system for traffic signals. Figure 10 shows examples of standalone solar and grid/solar hybrid power supply system schematics implemented in the CoJ.



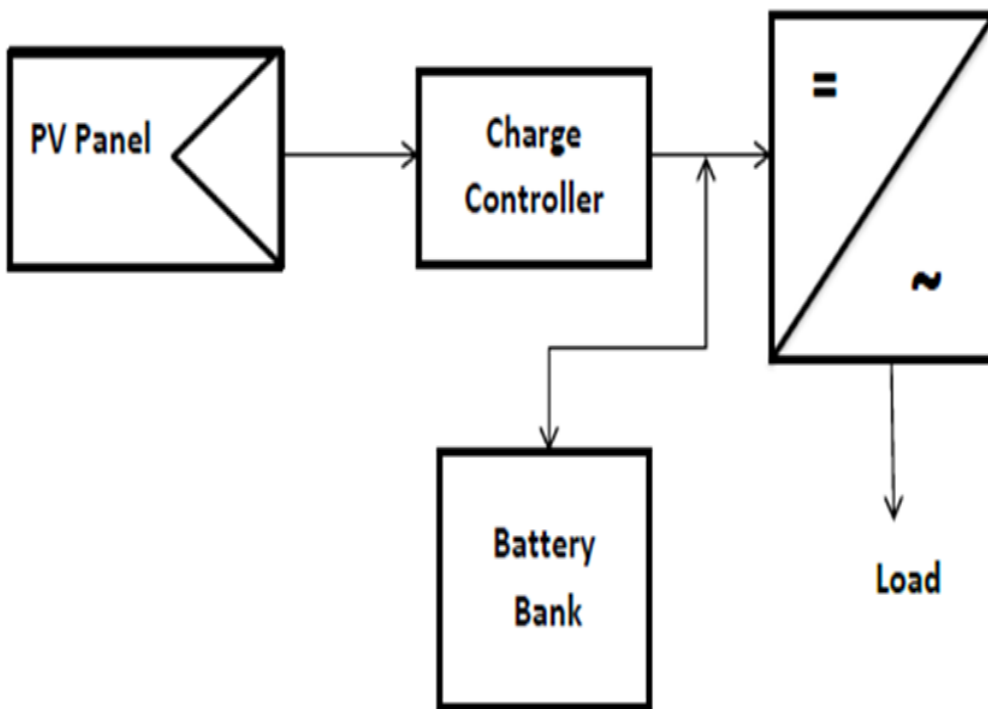

(a) Standalone solar

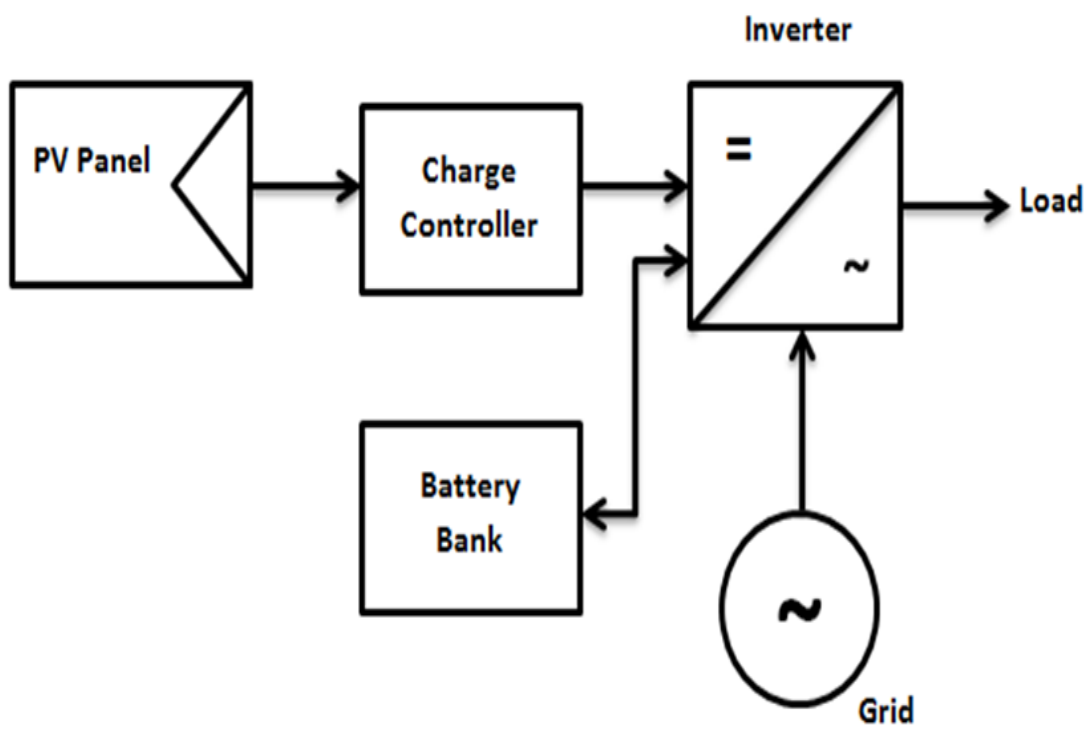

2Solar/Grid hybrid

Figure 10: Power supply system schematics.

From Figure 10, PV panel is the primary source of energy. The battery bank starts to supply energy when the PV panel does not supply sufficient energy. When both PV panel and battery bank do not have sufficient energy, the load in Figure 10(a) will not function whereas the grid in Figure 10(b) will supply energy to the load and battery bank.

#### 2.4.4 Maximum Power Point Tracking

Advanced solar battery chargers use maximum power point tracking as a technique to get the maximum possible power from photovoltaic solar panels. Therefore, a maximum power point tracker (MPPT) is an electronic DC to DC converter that optimizes the match between PV panels and the battery bank. The optimization becomes effective during cloudy, low battery state of charge and cold conditions.

MPPT adjusts the voltage at which the solar panels are able to produce maximum power. The difference between MPPT and conventional charger is that the conventional system connects the module directly to the battery, thereby forcing the solar module to operate at battery voltage. Figure 11 shows the MPPT operational principles demonstrated by Markvart (1994:107).

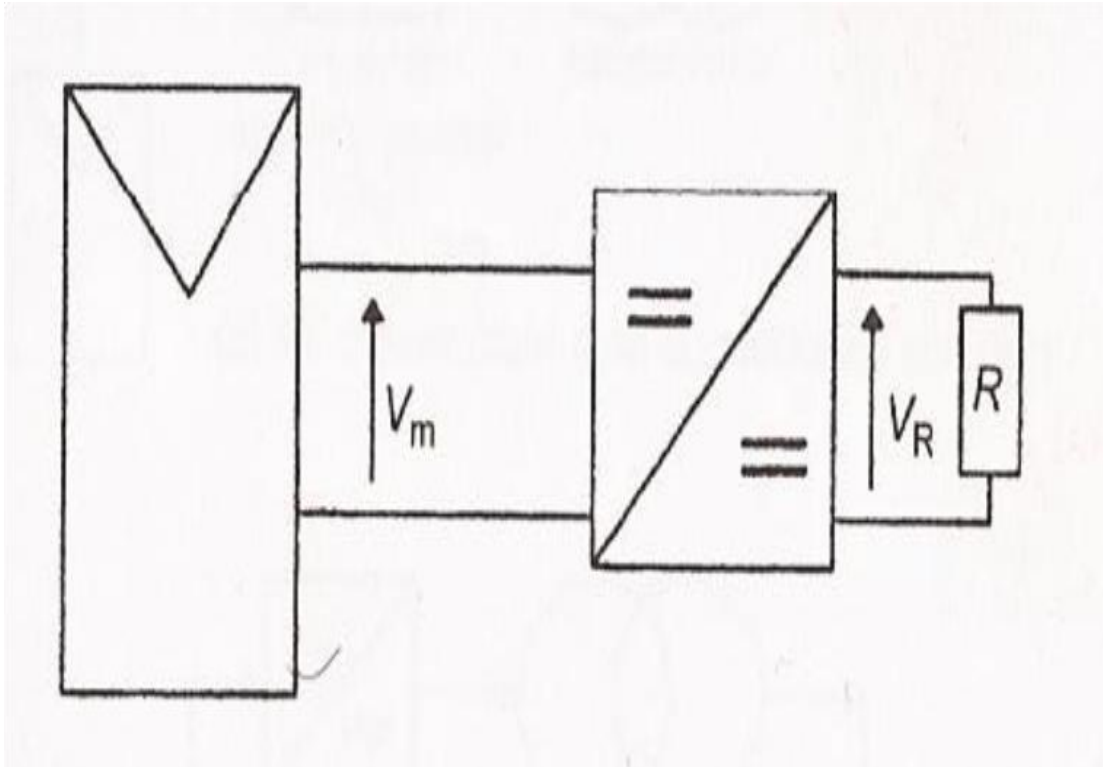

(a) Schematic diagram

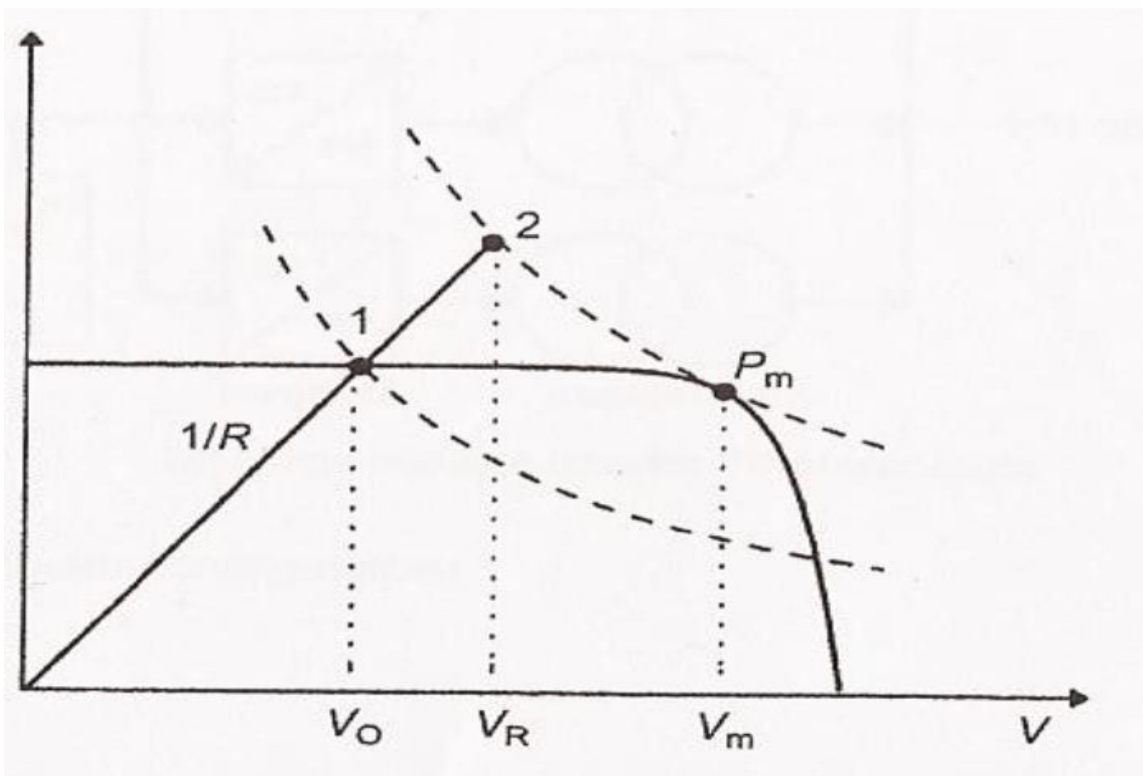

(b) I-V characteristics

Figure 11: MPPT operation.

Figure 11 shows that the DC/DC converter transforms the voltage at the load, to ensure maximum power transfer. MPPT implementation is important to increase the supply reliability, as recommended in section 1 of this dissertation.

#### 2.4.5 Ring Feed Network

Ring feed distribution network is network of parallel connected load, with redundancy feature. In other words, traffic signal heads per phase, at different poles of the same junction, get power at one point of same voltage. When a fault is persistent at one pole, the cables of the signal lights mounted on that pole can be disconnected, leaving other signal lights operational. The basic principle and schematic design are related to Figure 12, obtained from Wikipedia.

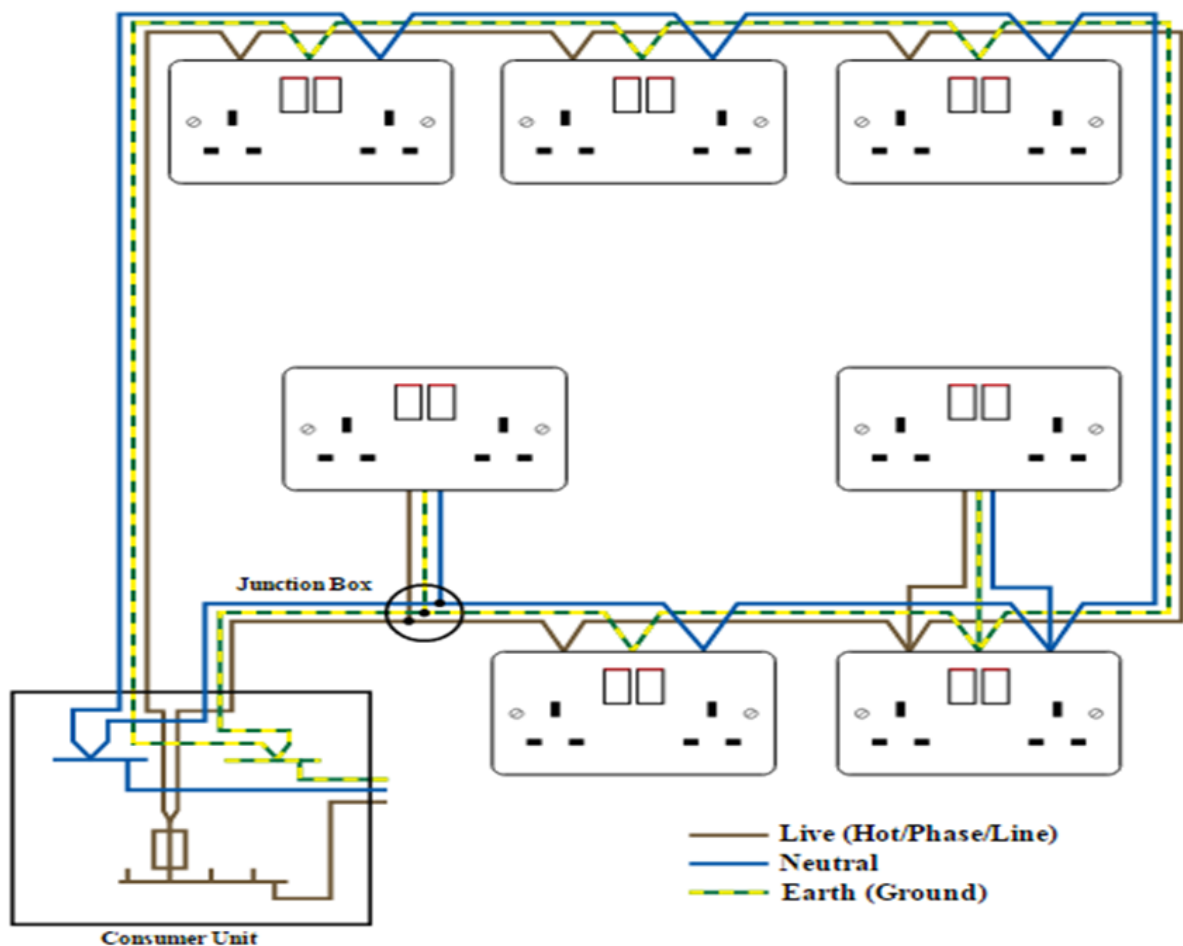

Figure 12: Ring-feed electrical power distribution network schematic.

## 2.5 Power Supply Performance Prediction

### 2.5.1 Load Prediction Modeling

Different models of electrical load prediction have been demonstrated by different researchers. Many researches may have not particularly been in relation to ITS problems, but they are also applicable. Application of AI techniques seems to be intriguing to many.

According to Weron (2006:78), additive models are by far more popular. Chen *et al.* (2001), also concurs, by presenting an additive model assumed to be a combination of four separate components, written as follows:

$$L = L_n + L_w + L_s + L_r \quad (6)$$

where  $n$ ,  $w$ ,  $s$  and  $r$  respectively represent the normal, weather, special and noise parts of system load.

Due to the nature of traffic signal control operation, the additive load predicting model has to be developed.

### 2.5.2 Battery State of Charge

State of charge (SOC) estimation is very important in determining amount remaining battery charge to supply the load. Different methods of determining state of charge of the battery have been presented by different researchers with aim of battery charging and discharge control and to determine battery runtime.

According to Coleman *et al.* (2007), Coulomb Counting, Voltage Indication and Impedance Measurement are the methods of assessing the state of charge of batteries presented by different researchers. Other researchers further implemented fuzzy logic, artificial neural network and neuro-fuzzy networks as computational intelligence systems to account for other conditional factors that affect the battery SOC. According to Moo *et al.* (2007), most of techniques for estimating SOC of batteries need very accurate measurements of either the

battery chemical content or its operating conditions and thus are suitable for laboratory experiments. The main methods presented are voltage and coulomb counting.

Voltage method is based on the terminal voltage of the battery. For an online battery, discharge and charging processes will have an effect on the SOC estimation. Feng *et al.*(2013) define the SOC as the ratio of actually available charge to maximum capacity charge of battery as described by the formula below.

$$SOC = \frac{Q_c}{C_t} * 100\% \text{ or } SOC = (1 - \frac{Q_b}{C_t}) * 100\% \quad (7)$$

$Q_c$ ,  $Q_b$  and  $C_t$  denote the remaining charge quantity, discharge quantity and maximum capacity, respectively.

Moo *et al.* (2007) also defined the battery state of discharge (SOD) as the percentage of the discharge capacity of a battery which is fully charged before discharging. This definition is illustrated by the formula below:

$$SOD = \left( \frac{Q_d}{Q_{rated}} \right) * 100\% \quad (8)$$

$Q_d$  and  $Q_{rated}$  are the discharged capacity and the rated capacity, respectively, both in Ampere hour (Ah). The conclusion in this regard by Moo *et al.* (2007) was that open-circuit-voltage (OCV) test is inapplicable for applications with series connected battery banks. Feng *et al.* (2013) put forward OCV extrapolation as the calibration and calculating basis of the coulomb counting method.

Coulomb counting is the current integration method of counting the amount of charge in or out of the battery over time. According to Leksono *et al.* (2013) Coulomb counting provides high accuracy but still requires compensation from operational condition such as OCV estimation method. Cai *et al.* (2003) define the battery SOC with the formula below:

$$SOC = \frac{C_a - \int i dt}{C_a} \quad (9)$$

$C_a$  is the available discharging capacity of battery that is fully charged, while  $i$  and  $t$  are the discharging current and time, respectively.

## 2.6 Communication Networks and Synchronization

There are two types of commonly used switched communication networks in ITS, namely, circuit-switched and packet-switched networks. They support the operation of SCADA. Real-time synchronization depends on suitable switched network, for good quality of service (QoS).

### 2.6.1 Circuit-Switched Network

According to Cisco, circuit-switched networks offer users dedicated bandwidth that cannot be infringed upon by other users. In modern networks, electronic signals pass through several switches before a connection is established. Modarressi *et al.* (2009) concur with Cheung *et al.* (1993), that the increase in such network type increases the contention among the circuits due to the restrictions of the topology, leading to long latency. An example of its application is DUSC RMS, from Siemens, whereby communication with Gemini outstations are based on infrequent GSM communication connections, according to Gilham (2001:7). The same applies to current traffic signal UPS monitoring systems in the CoJ. The basic phases of circuit-switched network are:

- Establish
- Transfer
- Disconnect

It should also be noted that if the network is inactive in ITS application, to establish connectivity or transfer data, the response time becomes prolonged or timed out, causing the SCADA to be ineffective.

### 2.6.2 Packet-Switched Network

According to Teach-ict, this is a method of breaking data files into small packets or chunks in order to send them across a network. Each packet may go a different route from the others,

with a header address that tells it where its final destination is. Figure 13 shows the basic concept of packet-switched network, with Figure 13(a) also presented by Stallings (2007:309). Wi-Fi, GPRS and fiber networks are common for packet switching network. With TCP/IP, connectivity can be tested by sending a “ping” instruction with the IP address of concern.

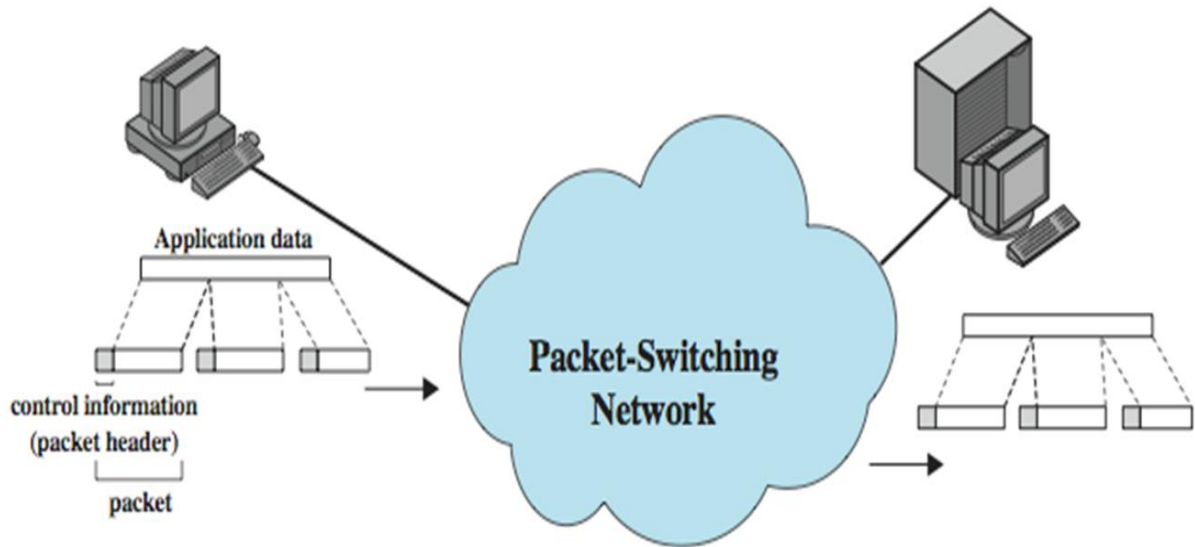

(a) Basic concept

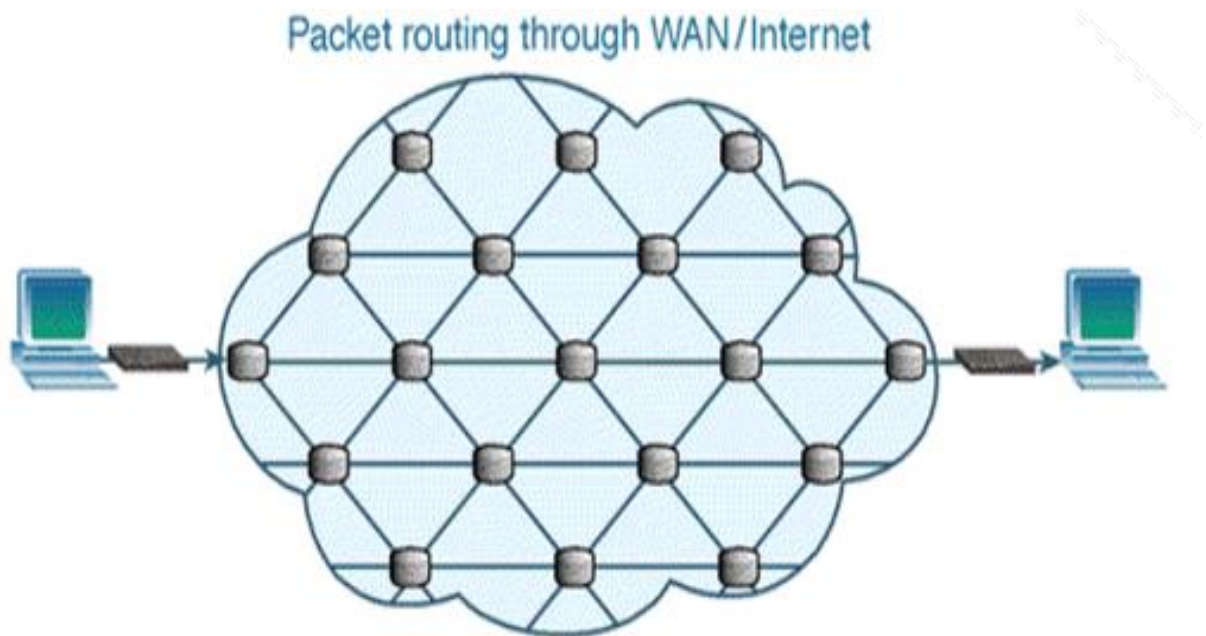

(b) Routing through WAN.

Figure 13: Packet switching.



A packet also contains total amount of packets to arrive to the recipient computer, to know of any failures. If any packet fails to arrive, the recipient sends a message back to sender, requesting missing packet. This is very important as the bandwidth gets to be used efficiently.

### 2.6.3 SCADA

Nowadays ITS operations need advanced supervisory control and data acquisition (SCADA) systems. Road transportation management operations also have power supply systems which need to be monitored remotely from time to time, to avoid maintenance uncertainties. Like in power supply operations, Miller and Malinowski (1994:137) also state that delays which could result from the need to send an operator to such locations may lengthen an outage and deteriorate customer service. It is also the case in the transportation engineering operations, whereby the dependence on motorists to report on faulty traffic signals, makes it uneconomically efficient for a city like Johannesburg. This led to the development of current SCADA systems which consist of master station or terminal unit (MTU), remote terminal units (RTUs) and some communication links between the master and remote units. From Durrani *et al.* (2013), it can be added that RTU is connected main monitoring center via GSM/Satellite/Ethernet connection, IP connectivity via EDGE/3D where applicable.

As supported by Babovic and Velagic (2009), SCADA systems provide industry with safe and reliable tool for remote monitoring and control. Some of the expected benefits of using such systems are as follows:

- Automatic report generating,
- Troubleshooting,
- System modifications,
- Real-time monitoring, etc.

It is furthermore stated that the network configuration also plays a crucial role in real-time operations. Of course, there are different SCADA implementations in ITS. A standard SCADA system block diagram is shown on Figure 14.

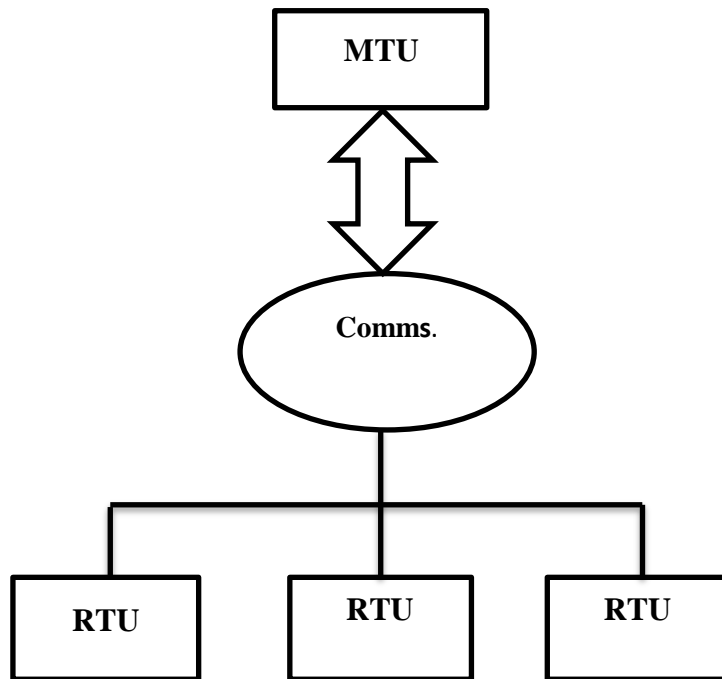

Figure 14: SCADA block diagram.

## 2.7 Systems Reliability

Reliability of ITS is very important, for it is the main concern to which the problem and its sub-problems, in this dissertation are attributed to. Wang & Wets (2013:245) clarify reliability as the ability of technical item to perform one or more required functions, under given environmental and operational conditions and for a stated period of time. Middleton *et al.* (2009) support the concept, with emphasis on consistent performance without a need for human intervention. Figure 15 illustrates reliability function over time.

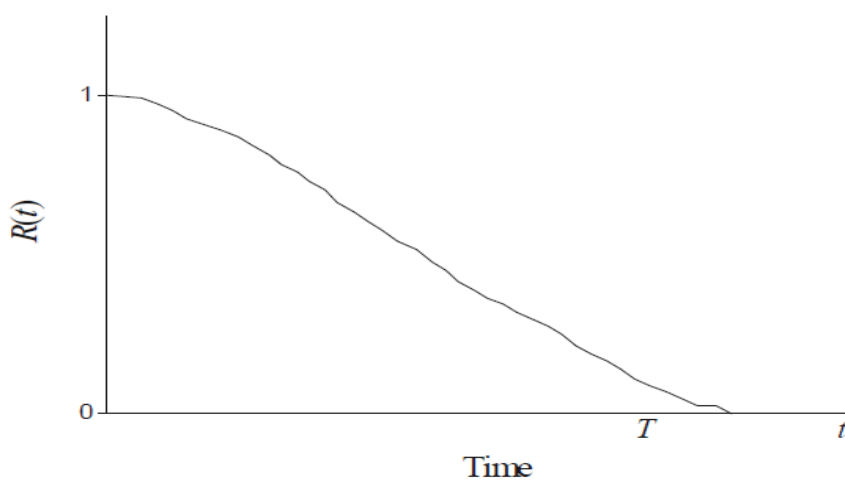

Figure 15: Reliability function

Reliability of systems per traffic signal junction can be broadened towards reliability of a coordinated signals network. In this case, time-space diagram can be useful in assessing the impact of systems reliability. In addition, reliability of communication systems can be attributed to consistent link and transmission speed between in-station and outstation components, thereby enhancing the overall system QoS.

### 3. Analysis of the current situation on ITS faults and maintenance uncertainties in the City of Johannesburg

#### 3.1 Introduction

Major intersections are situated along major and minor arterial routes, within the CoJ municipality. Other intersections are along the collector or local routes, especially in central business district (CBD). Figure 16 below, shows the CoJ map, with its arterial, collector and local routes.

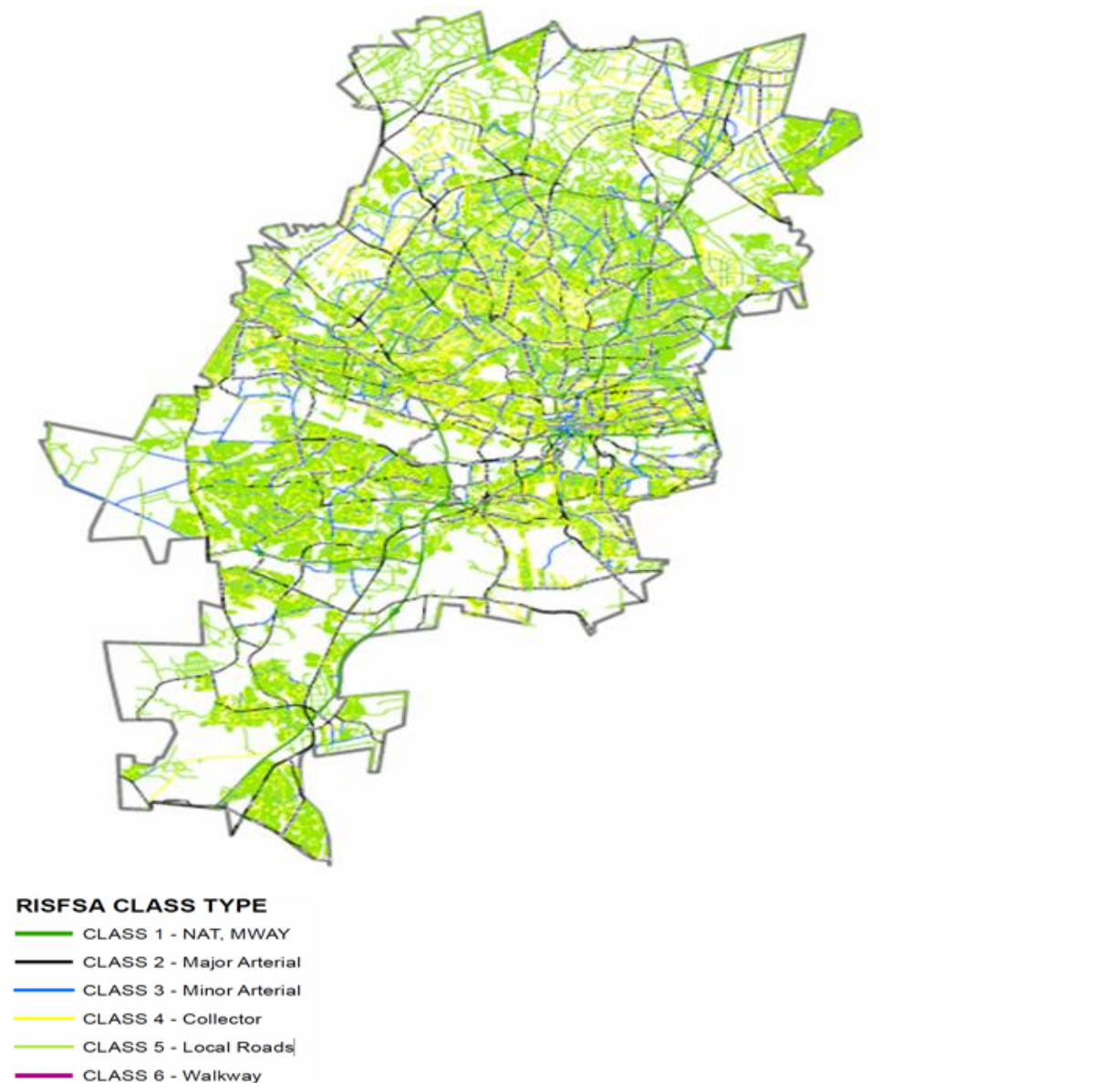

Figure 16: CoJ metropolitan municipality map

More than 60% of the selected intersections have four or more street lanes, regardless of the direction of such lanes. Some of them have right-turning lanes, with special traffic signal light heads installed to accommodate the signal timing plans. Considered junctions can be categorized as 2-way, 4-way and T-junction. Their signal heads are also implemented accordingly, to comply with SARTSM requirements. The length around such intersections is between 70 and 100 meters in approximation. Figures 17-20 show the layout of traffic signalized intersections with four or more street lanes, obtained from JRA's traffic engineering department.

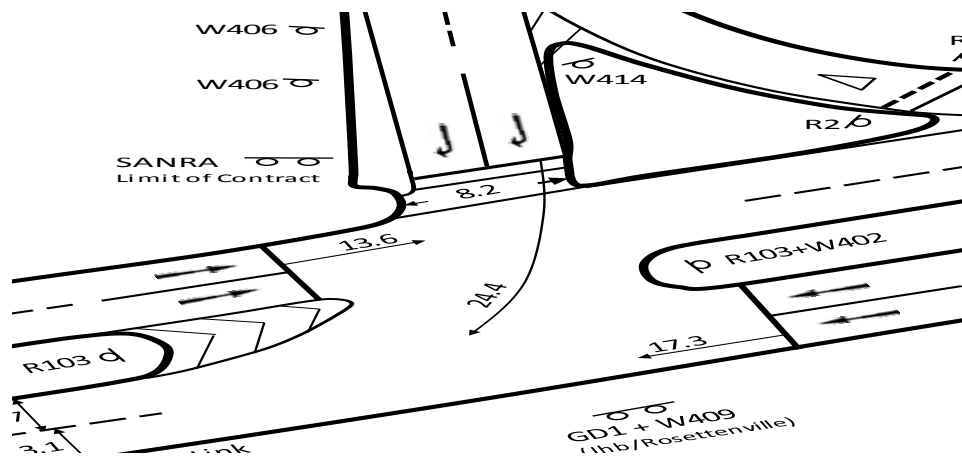

Figure 17: Junction with 2-way 4-lane street.

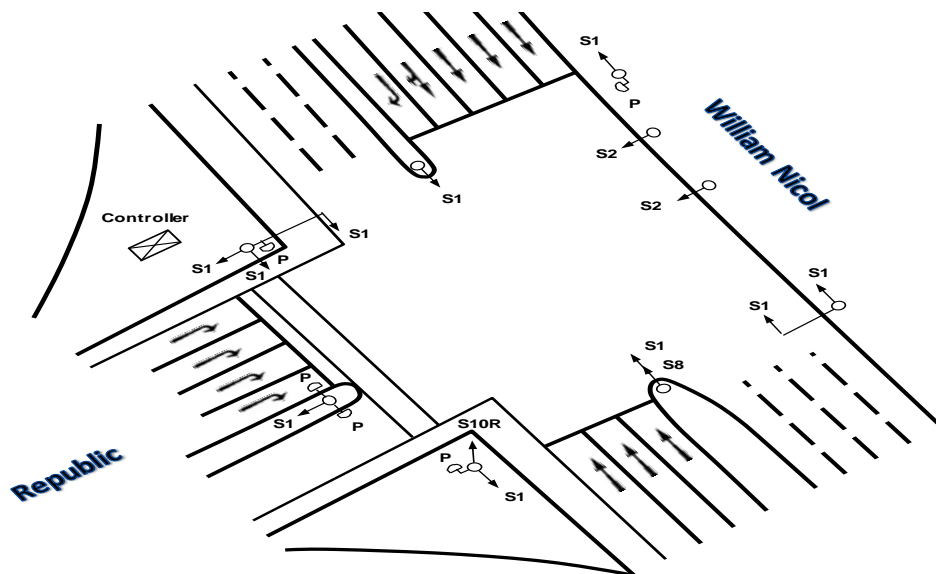

Figure 18: Junction with 2-way 7-lane street.

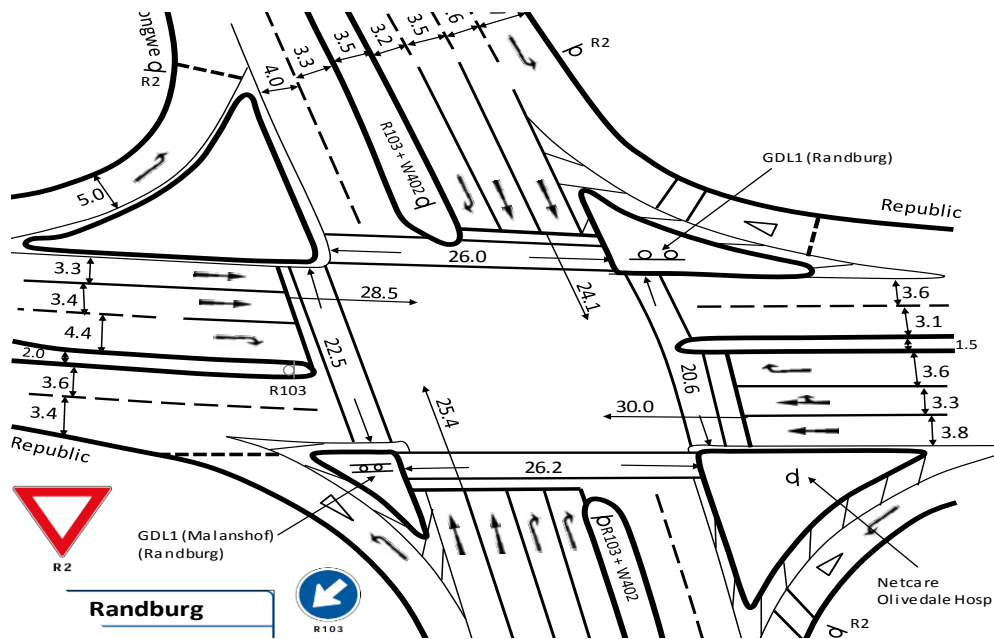

Figure 19: Junction with 2-way 5-lane streets and right-turn lane.

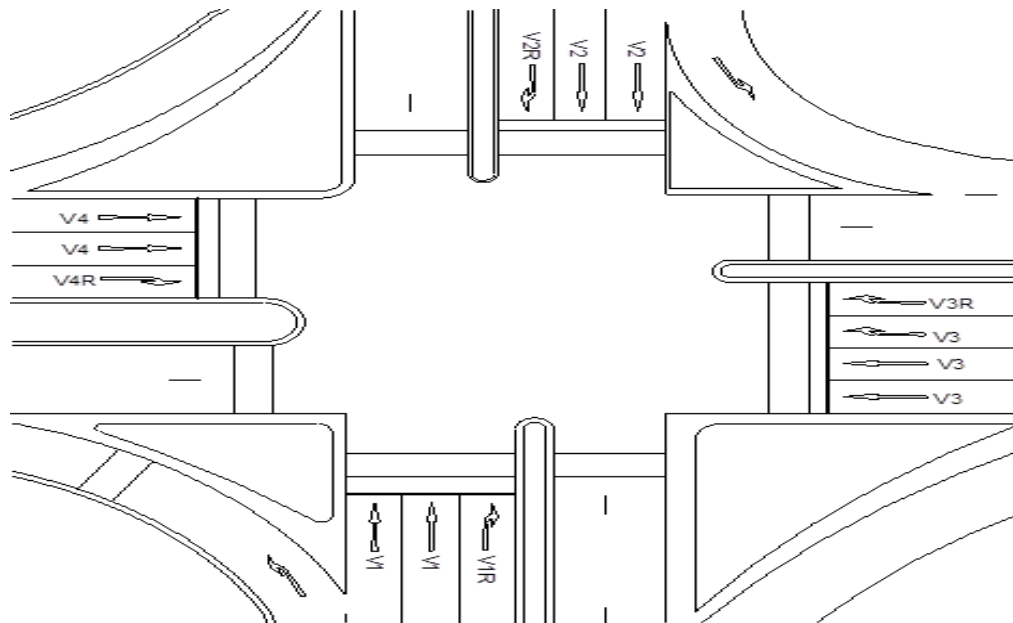

Figure 20: Junction with 2-way 5-lane streets and right-turn lane.

Over 85% of the major junctions are of fixed timing plans. Some corridors have consecutive junctions laid out as shown in Figure 21, with vehicle movement directional arrows.

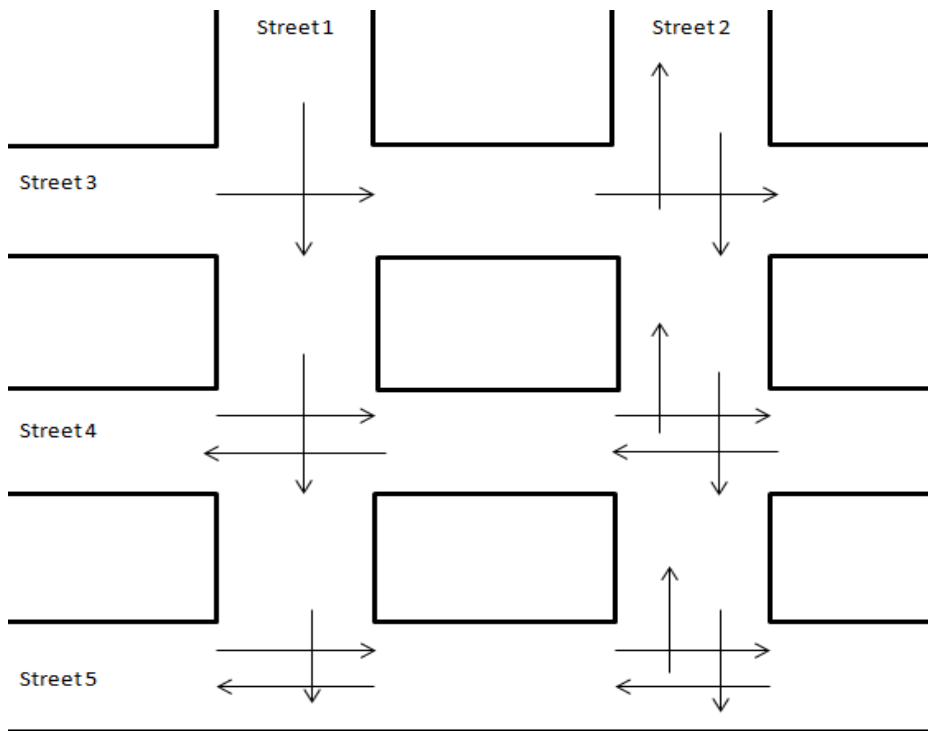

Figure 21: Consecutive junctions of different layouts.

Figure 22 shows, in block diagram, the current ITS architecture of concern to this research.

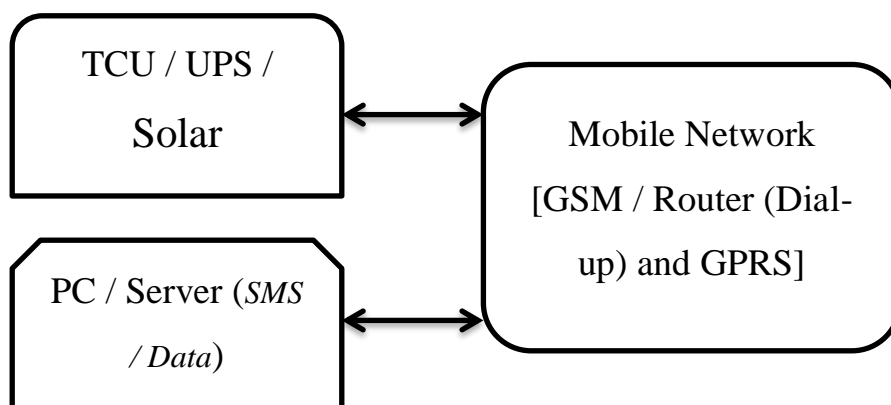

Figure 22: Current road ITS architecture.

Table I shows the information collected on alternative energy supply, at major intersections. The output power is of pure sine wave.

Table I: Information on JRA's traffic signal backup and alternative power supply systems

Type	Power Out	Config.	H	Estimated autonomy	Maximum estimated load	Battery cutoff level
UPS	600VA	Line-interactive	67%	4 hours 2*54Ah 12V battery	500W @ 220Vac	10~20%
UPS	700VA	Line-interactive	67%	4 hours 2*54Ah 12V battery	500W @ 220Vac	10~20%
UPS	1500W	Stand-by	85%	7 hours 4*102Ah 12V Battery	500W @ 220Vac	10~20%
UPS	2000V A	Line-interactive	67%	4 hours 2*54Ah 12V battery	500W @ 220Vac	10~20%
UPS	3000V A	Line-interactive	70%	4 hours 2*54Ah 12V battery	500W @ 220Vac	10~20%
Solar	1500W	Hybrid (Solar & Grid)	85%	3 days Various batteries	500W @ 220Vac	10~20%
Solar	2300V A	Stand-alone	90%	7 days Various batteries	500W @ 220Vac	10~20%

With reference to Table I, the assessed backup and renewable power supply systems are installed along arterial routes which also intersect. 20% of UPS systems are of less than 70% efficiency, with only two batteries per intersection. 75% of the systems are standby UPS systems of different battery configurations. Solar systems constitute the remaining 5% of the total.

The installation of some power supply systems is inconsistent with the estimated autonomy and power supply synchronization. The inverter's transfer function or efficiency and the true



output power are not considered in line with the load per traffic signal junction. The situation becomes worse when traffic signals maintenance is not of good quality.

Table II shows information gathered about the traffic control and communication components and the power supply.

Table II: Traffic control and communication components

<b>System</b>	<b>Components</b>	<b>Power source</b>	<b>Power rating</b>
Traffic Control	Traffic signal controller	AC	+/- 70W
	LED	AC	< 15W
SCADA Communications	Modem	DC	24Vdc
	MCU	DC	12Vdc
	Router	DC/AC	12~50Vdc 85~264Vac

### 3.2 Faults Analysis

Systematic faults of concern in this research, which are reported by the public and through RMS, as part of ITS, are all-out and flashing red. Such faults result from systematic interruptions on traffic signals. The interruptions may be caused by electrical power instability or fluctuations. Sometimes the utility grid may just be off, but when it is on, the TCU may detect an error and keep the signals on flashing mode. Mohan *et al.* (2003:354-355) also give the relevant list of power line disturbances.

JRA, the entity of CoJ, gets power supply for ITS, from ESKOM, South Africa's main grid utility company or City Power, CoJ's entity for electricity, depending on area or region. According to ITS maintenance team, it has been discovered and confirmed by utility companies' technical teams that in industrial areas, supply voltages are increased at mini-substations to cover up on the supply volt drops caused by heavy operations. Such mitigations, however, negatively affect the traffic signals operation as the voltage may rise

above the maximum or decrease below minimum required input AC voltage during peak and off-peak hours respectively, due to grid fluctuations.

At intersections with solar or uninterruptable power supply systems, there exist stored energy losses during supplying time. The lost energy is due to DC/AC power conversion as the main ITS is driven by AC power. Current ITS energy conversion UPS models decrease power efficiency and reduce the actual and expected capacity. Installed UPSs use AC/DC to DC/AC and solars use DC/AC electrical energy conversions, when supplying power to TCU.

It should be noted that about 10~ 20% of stored energy must be retained per full battery bank discharge cycle, to maintain storage lifespan. So, the energy can be used when the grid supply is off, is very limited.

With reference to table I, it is deduced that the following formula was used when planning for existing alternative energy implementation:

$$Q_{req} = Q_{bb} - Q_{off} \quad (1)$$

where,  $Q_{req}$  is the required charge

$Q_{bb}$  is the battery bank charge

$Q_{off}$  is cut-off charge

The stored energy  $Q$  is expressed in amp-hour (Ah)

where

$$Q = I * t \quad (2)$$

for  $I$  is the charging current

$t$  is charging time

From (1), it is further deduced that the load supplied power is derived as follows:

$$P_l = V_s(Q_{bb} - Q_{off}) * \eta \quad (3)$$

where,  $P_l$  is load supply power

$V_s$  is supply voltage in  $V_{dc}$

$\eta$  is inverter efficiency

Traffic signal intersection load can be obtained as follows:

$$L_t = n_5L_5 + n_3L_3 + n_pL_p + L_{tcu} \quad (4)$$

where  $L_t$  is total load

$L_5$  is 5-light head load

$L_3$  is 3-light head load

$L_p$  is pedestrian light head load

$L_{tcu}$  is TCU load

$n$  is quantity of specific light head.

Table III shows traffic signals faults data recorded during September 2013, at major intersections. More than 95% of initial reports per junction were coming from members of the public, instead of installed RMS.

Table III: September 2013 traffic signal faults data

<b>Date (Sept 2013)</b>	<b>Daily faults recorded</b>	<b>All Out</b>	<b>Flashing Red</b>
2	36	32	4
3	39	31	1
4	62	47	4
5	63	58	1
6	57	47	4
9	73	51	8
10	56	41	4
11	44	33	5
12	52	37	5
13	62	40	10
16	61	42	5
17	72	48	7
18	89	59	11
19	58	36	6
20	41	35	2
23	34	27	1
24	No data	No data	No data
25	45	38	1
26	38	27	8
27	No data	No data	No data
	<b>Average daily faults</b>	<b>Average A/O</b>	<b>Average F/R</b>
	52	39	06
		75%	11%

With reference to Table III, “all out (A/O)” and “flashing red (F/R)” are the two systematic faults dominating the daily and monthly faults report. During faults maintenance activity analysis, it has been discovered that A/O is caused by utility grid network problems. The major causes are overvoltage, under-voltage and outages. Since many faults were reported by

motorists, most of them are reported after over half an hour from the time of occurrence, as many reporters use their office phone numbers after getting to their workplaces.

Due to sensitivity of traffic signal controllers, F/R faults eventually take place as a result of persistent grid network problems. UPS configuration, incompatibilities between TCU and LED lights also play a role in systems reliability.

It has been discovered that the grid supply voltage can go below minimum threshold, backed up by standby UPS, with battery charge close to cutoff level, while multiple fluctuations take place at the same intersection. When the signal timing imposes the higher load, the TCU may detect persistent system error that can take longer, even when the grid power is restored. Due to such error, the TCU turns the signal heads to operate on F/R mode.

F/R can also take place where line-interactive UPS is installed, due to grid fluctuations. This is due to the fact that battery charging takes longer whereas discharging is quicker. Other batteries at other assessed junctions are older than others, with no replacement plan in the maintenance department. It is even worse with old batteries, when charging cycles are interrupted by grid instabilities.

It has been discovered that the grid network has different supply points, supplying junctions along the same street. It becomes worse when such points belong to different utility companies, which is found to be the case in CoJ. With many junctions operating on fixed timing plans, the statistical traffic signal optimization does not become effective as the junction synchronization becomes affected by grid instabilities. Mobility becomes affected and worse where adjacent streets are closer whereby, road network nodes are created.

Figures 23 and 24 are graphical analysis to show and confirm that of all daily faults recorded, an average of about 75% of all-out and 11% of flashing-red faults are reported, making a total of about 86%.

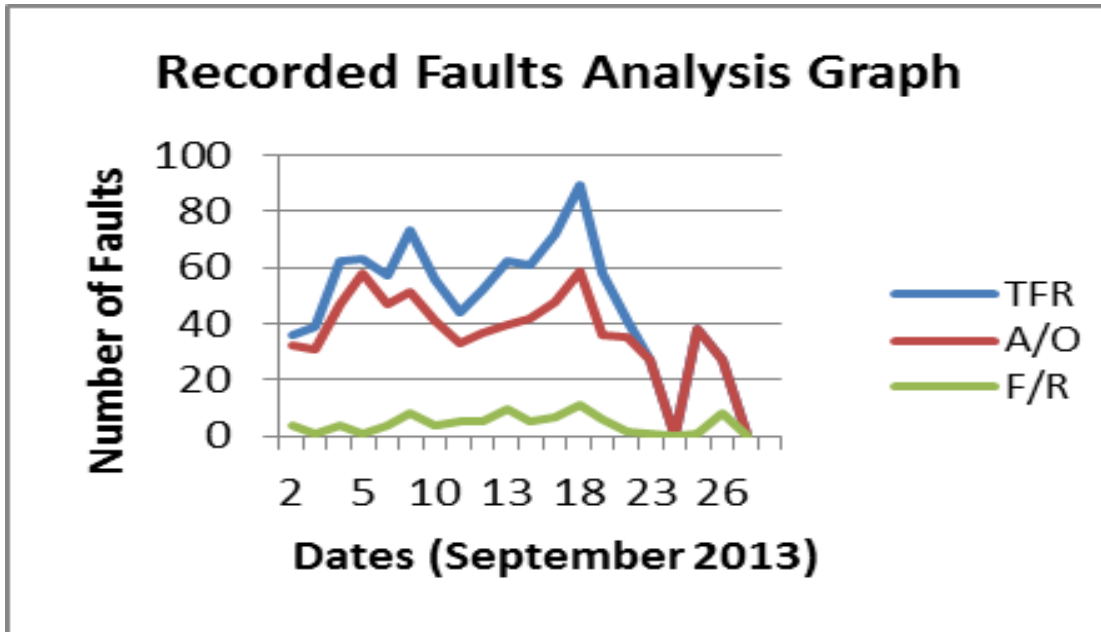

Figure 23: Recorded traffic signal faults analysis.

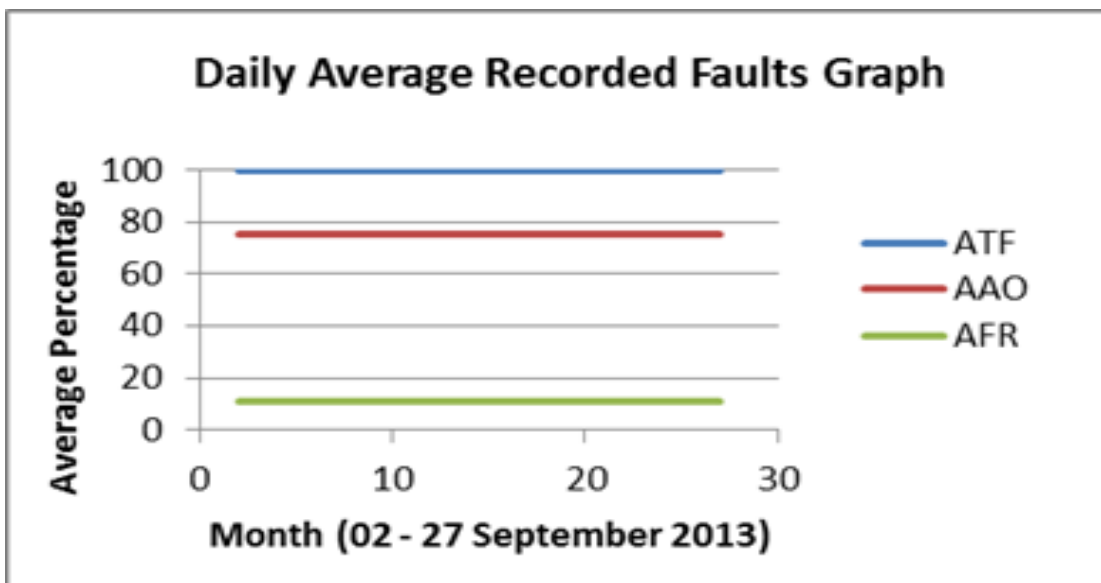
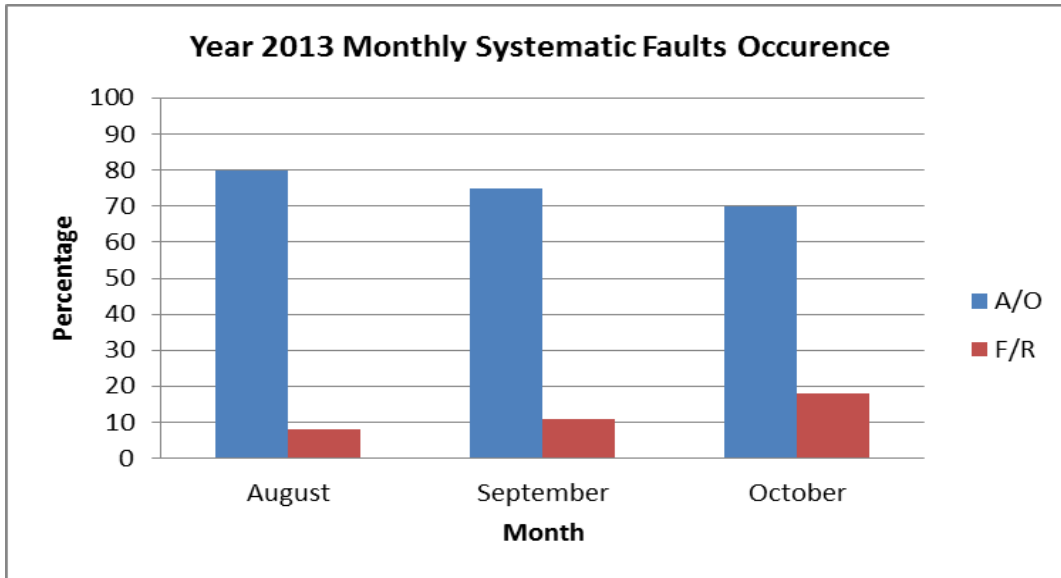
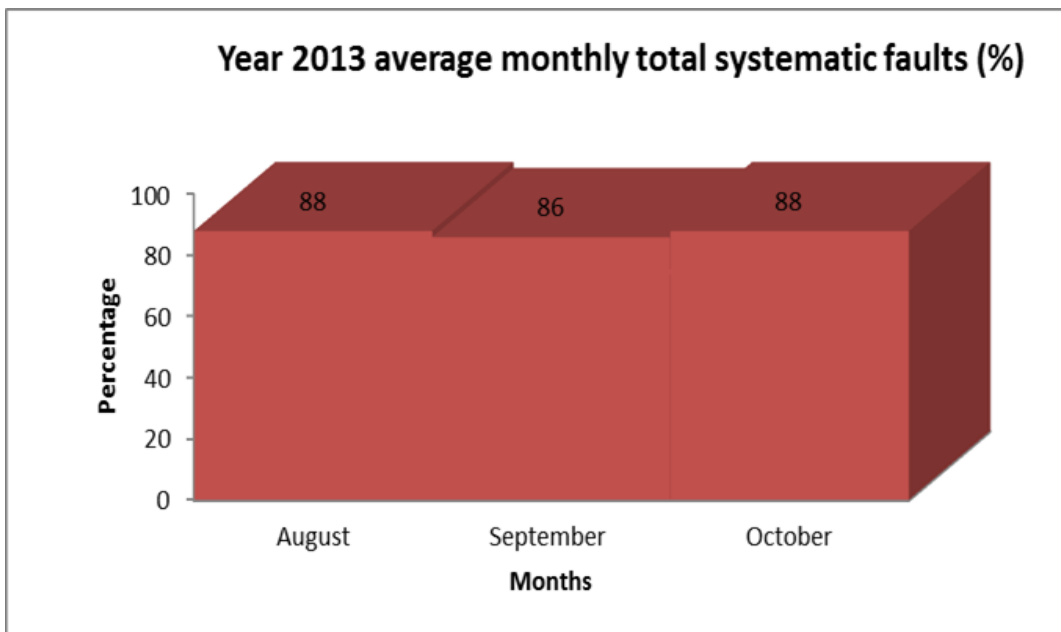

Figure 24: Daily average traffic signal faults occurrence analysis.

The recorded data for a month before and after September 2013 also confirm the analysis, as illustrated further, in Figure 25.



(a)



(b)

Figure 25: Monthly faults analysis

It is also deduced that recorded systematic faults affected almost 25% of major intersections, in average, during September 2013. This also negatively affects maintenance target of less than 1% of malfunctioning traffic signals per day

In the existing ITS, three UPSs of equal lead-acid battery banks have been charged to the maximum charge at intersections of different layouts and fixed timing plans, but when the grid supply is switched off, their operating times were different due to efficiency and timing plans related load per intersection. For instance, when many preview signal heads are used at other junctions, like four-way junctions, and the turning arrows are implemented for specific timing plans, such junctions require more electrical energy than others.

In traffic signals control systems, many controllers are very sensitive to the power supply. Such high sensitivity causes the intersection signals to flash red, then result in traffic congestion. The feedback from many LED lights has been found as one of causes of the problem.

Steps taken, by technicians and electricians, to eliminate such a problem, have always increased considerably high load against energy saving approach. Transformers, incandescent and halogen lamps have been installed inside controllers which could not withstand the feedbacks from LED lights. Such devices, however, have increased load with their high energy consumption. Therefore, such maintenance procedure is not energy efficient.

The additive load model in (5) is casually supported for quick maintenance that turns out to be permanent, for TCU stability:

$$L_{lab} = L_t + L_x \quad (5)$$

where,  $L_{lab}$  is the abnormal load

$L_x$  is extra load

However, (5) ignores energy efficiency initiatives at traffic signal intersections as the alternative energy or backup storage is subjected to abnormal load and against expected autonomy.

Figure 26 shows the discharge curves of fully charged UPSs, at different intersections, starting at the same time.



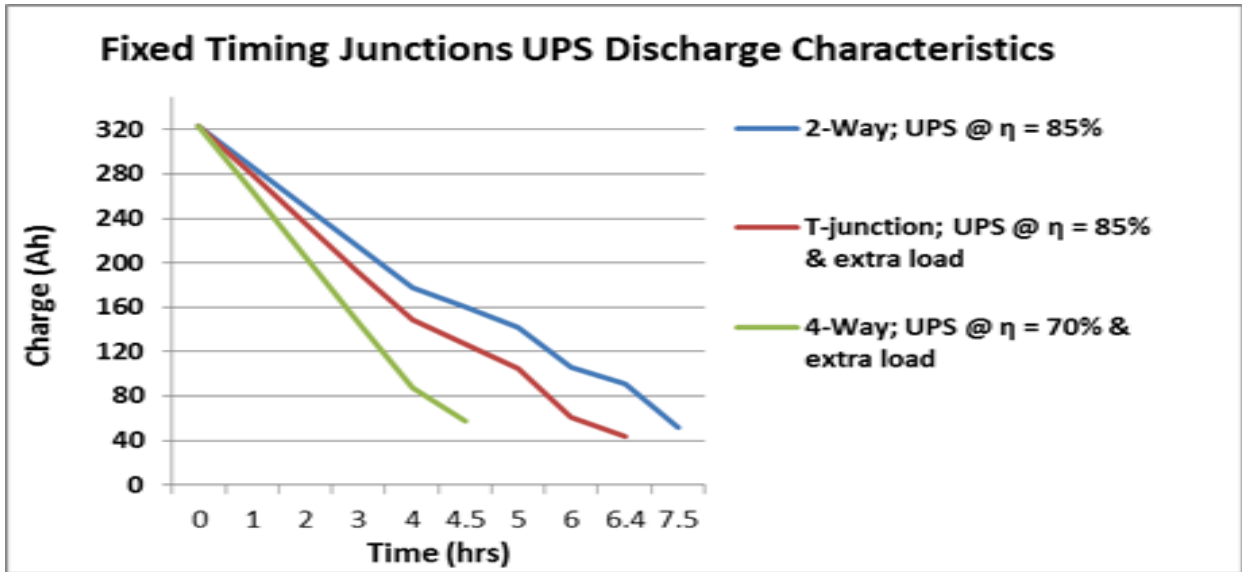

Figure 26: UPSs discharge characteristics.

From Figure 26, it can be concurred with Cultura II and Salameh (2003), that the lower the discharge time, the lower the efficiency.

Krauter (2006:64) describes battery energy efficiency as a function of discharge current. With the aid of discharge current characteristics of lead acid battery, he shows that low efficiencies are caused by high discharge currents. It is also a similar case, as can be analyzed from Figure 26, of this research. The higher the load, the higher the required current and shorter the backup time becomes.

From Table I, elimination of electrical energy double conversion is expected to add approximately 15~30% of backup operating time per respective junction. At assessed junctions, extra load may constitute 15~30% of maximum estimated traffic signal junction load.

Considering traffic signals junction layout is very important, for synchronization and reliability support modeling. If the three examined UPSs were along the same main road, one after another, traffic signal junctions' synchronization would be completely out, allowing for traffic congestion, especially during peak hours.

### 3.3 Maintenance uncertainties

Current ITS systems experience a variety of maintenance uncertainties. Some of them are listed as follows.

1. Different SCADA systems have been implemented. Depending on the manufacturer of the traffic control system, some dashboard information does not give the true reflection of real-time technical information received from the intersections. An example of that is when the dashboard shows that the intersection is online, while showing the communication networks signal strength at zero. This leaves every information not reliable, for the synchronization does not take place between outstations and the in-station communication systems. Such a problem leaves the TMC with no option, but to rely on calls from motorists. This has become evident with reference to table III, as the faults reports came from members of the public, most of whom were motorists.
2. Some devices are of dial-up operation, which makes it difficult to receive real-time information. The worst is that a server connected to multiple in-station devices may have been allocated for groups of out-station devices, which causes confusion and inefficiency in ITS monitoring and energy saving respectively. Short Message Service (SMS) communication is used but some messages take longer to be delivered to their destination, and such a process renders the system not helpful.
3. When power fluctuations take place, some intersections get to be reported as off, however, maintenance personnel may find the traffic signal system in good working condition. Sometimes, the grid power may be below the required minimum supply voltage. Irrespective of consideration on the energy efficiency and UPS type, very often, the strength of road ITS does not incorporate the importance of power supply performance or runtime estimation when the primary power supply source is off.
4. Available energy capacity per intersection, with backup power, is not measured per downtime, for maintenance priority. It makes it difficult to prioritize faulty intersections for maintenance against set standards.

## 4. Proposed solution, modeling and configuration of energy efficient roads ITS

### 4.1 Introduction of the proposed solution

There is a need to eliminate systematic faults interference through integrated and energy efficient ITS. According to the faults and uncertainties discussed in the research, the following strategies are proposed.

Since the length around many assessed intersections is estimated between 70 and 100 meters, it is proposed that power distribution from the traffic controller to traffic light heads should be of DC, in ring feed. According to Thomasnet, to reduce the risk of power supply distortion, UPS systems are often incorporated in electrical networks. Rasmussen also outlines different types of UPS, however, it is proposed that UPS double conversion of electrical energy supply to traffic control systems must be eliminated.

Maximum power point tracker (MPPT) is also recommended, for photovoltaic (PV) generator special interface measures, to ensure that there is maximum energy transfer from the generator to the battery. It is therefore, recommended that intersections with solar systems need charging controllers with MPPT features. This will also increase the efficiency and autonomy of energy storage. Negative effects of utility grid instability shall also be eliminated. Figure 27 shows the standard AC/DC and DC/DC converters concepts.

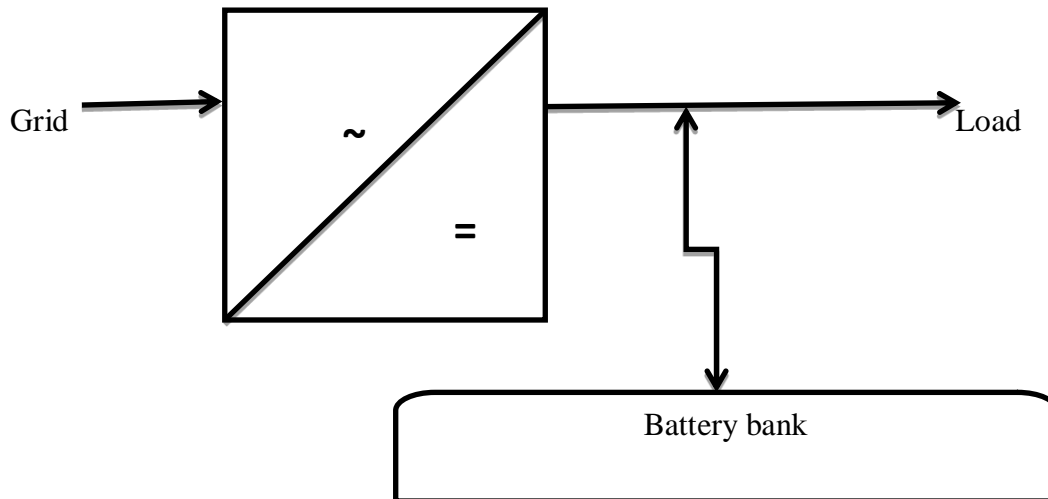

(a) AC/DC

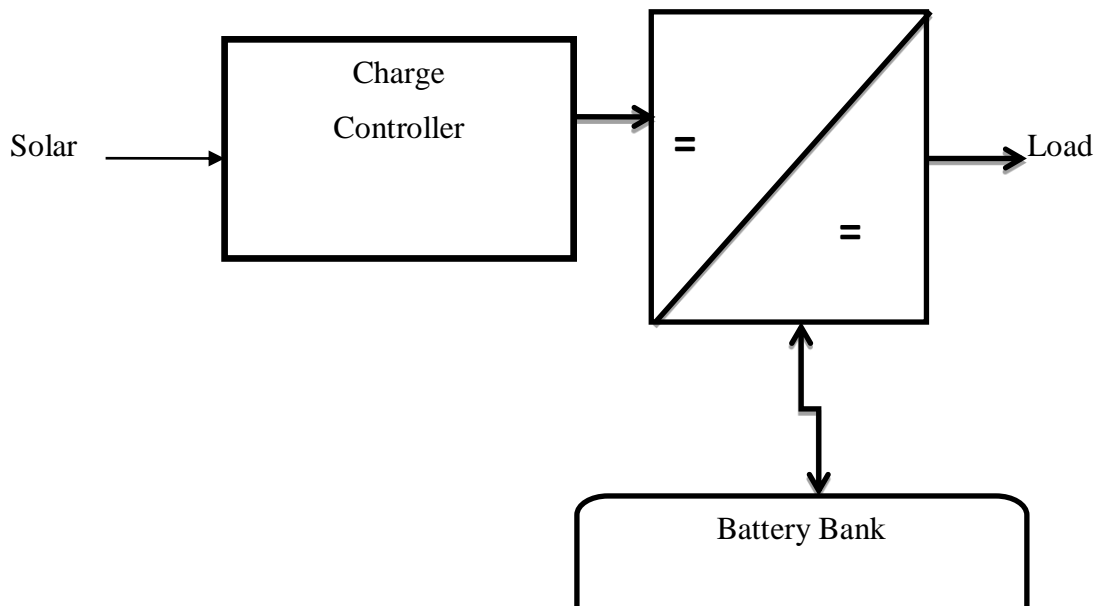

(b) DC/DC

Figure 27: Standard conversion concepts.

Shiranaga and Ogawa (2012) also developed a similar model related to Figure 27(b), for their ultra-low consumption traffic signals.

From Table 1, elimination of DC/AC transfer function can increase 10~33 % of efficiency on currently implemented backup and alternative power supply systems. It can also be noted

from Intelight's confirmation of approximately 15% increased power efficiency on its 357 ITS v2 cabinet model that operates on 48Vdc supply.

Electrical power supply strategy for traffic signals and their remote monitoring systems can have a negative or positive impact on energy efficiency or saving. Power source stability modeling is important, to ensure that ITS will not encounter frequent interruptions that have negative impact on mobility. Therefore, it is important to consider regulating the source output power and energy storage optimization.

It is important to extract information from the intersection's backup power systems and signal timing plans, for performance time estimation when prioritizing energy restoration at intersections which are running on alternative or backup power. The complexity of processing such information needs some forms of artificial intelligence methods, such as Fuzzy Logic (FL) and Neural Networks (NN).

Lee *et al.* (1992), also state that an artificial neural network (ANN) as a computing system is made of a number of simple and highly interconnected processing elements, which processes information by its dynamic state response to external inputs.

Such information is also important for on-road motorists' awareness, through Advanced Traffic Management System (ATMS).

Effective reactive maintenance needs advanced information systems, in order to eliminate uncertainties when disseminating the message to relevant stakeholders. Different incidences require proper prioritizing method or system for smart maintenance. Power source performance optimisation technique is therefore required for road ITS and it must focus efficiency optimisation, load and performance prediction, as the major factors. Intelligent techniques are applied in optimisation of power source performance for sustainable and efficient autonomy on traffic control systems. Different traffic signal control modes are considered, as applicable and common in traffic engineering, in accordance with SARTSM.

The TCU and LED lights interfacing needs to be redeveloped, to eliminate compatibility related faults. Such design must bring about reliability against feedbacks from LEDs to a sensitive TCU.

Remote monitoring communication systems should also be configured in energy efficient manner. This includes having an in-station device that accommodates all out-station devices. Automated real-time information system configuration is important, for simultaneous multiple monitored and controlled traffic signal junctions. Aras *et al.* (1994), emphasize that in real time computing, the distinguishing feature of real-time communication is the fact that the value of the communication depends upon the times at which messages are successfully delivered to the recipient.

It does not help to have well developed road traffic control systems and fault detectors, without realtime information system. Good communication network, with high QoS, is needed in ITS. Therefore, private packet switching and synchronization configurations are important.

#### 4.2 Energy storage efficiency optimization

This focuses on increasing the efficiency of the battery storage. Current batteries are of 12V nominal, however, high amount of electrical current is required to supply power of around 240W, as estimated by Coetzee *et al.* (2008). The higher the current drawn from the battery, the higher the temperature will become. 12V battery configuration is not ideal.

According to Ermon *et al.* (2012), battery energy is partially wasted due to internal resistance, during charging and discharging process. This is in addition to the actual delivery capacity which depends on the discharge rate.

It is therefore recommended that 48V battery configuration should be used with reference to the estimated length around the traffic signal junction and ring-feed configuration, as proposed in this section of this dissertation. In addition to selected batteries operational specifications, the 12V batteries should be configured as shown on Figure 28(a), with further configuration of such series connected segments, in parallel as shown on Figure 28(b), to promote current division amongst current exit battery terminals. In general, the use of multiple-battery configuration should be used.

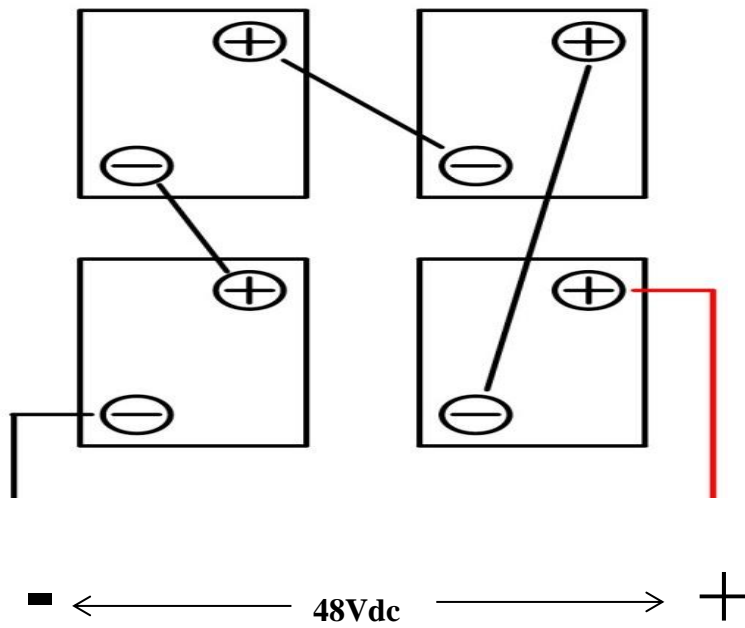

(a) Batteries in series connection

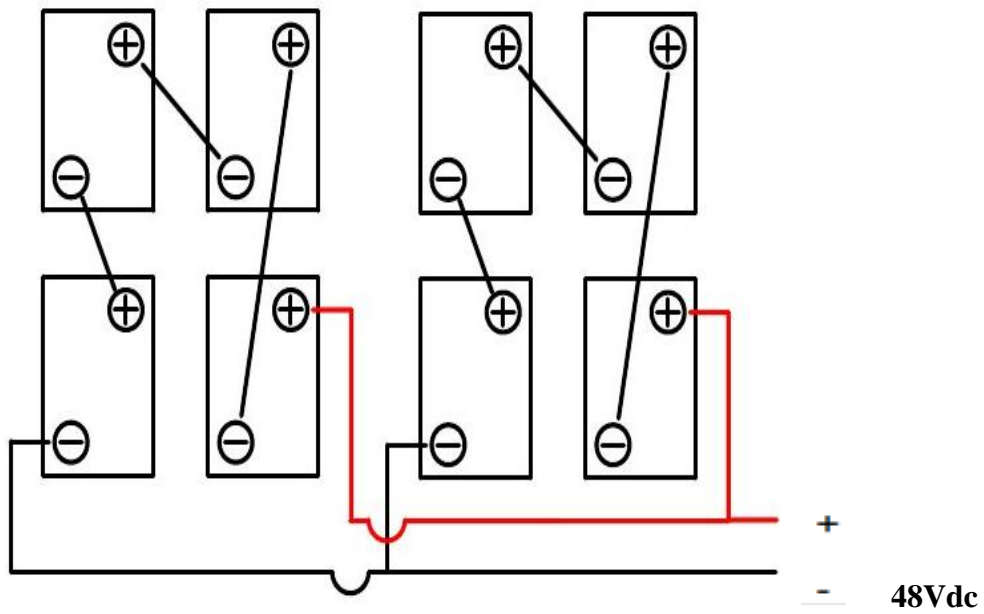

(b) Batteries in parallel connection

Figure 28: Multiple-battery configuration.

The basic principle is that total supplied current from Figure 28(b) is the sum of series connected segments, as shown by formula (10).

$$I_c = I_{ss1} + I_{ss2} + \dots + I_{ssn} \quad (10)$$

where,  $I_{ss}$  is series segment current

As useful as the battery monitoring system is, during charging process, it is also important to monitor the battery when it takes over from the main source. This is to ensure that battery bank is not negatively affected by unlimited discharge process. It is advisable to discharge 80 to 90 percent of the battery, leaving 10 to 20 percent remaining before the next charging process, to sustain the lifespan of the battery bank.

As opposed to the implementation of any of the systems concepts shown on Figure 9 and 10, of this dissertation, the basic concept shown on Figure 27 is the most relevant in increasing the efficiency of the backup power supply system. The aim is to get the battery bank stored energy supplied to the load, with minimal losses incurred. The confirmation in section 3, of addition in efficiency shows that the total system efficiency can reach 99%. Therefore, efficiency model should be worked out as follows:

$$\eta = \frac{P_{out}}{SOC} \quad (11)$$

where  $P_{out}$  is the battery bank output power

High energy losses should be minimal, when the battery bank discharges current to the load. This can be attained by using DC energy saving devices. This should include the thickness of power distribution cables. Electronic regulation should be of ultra-low power dissipation.

#### 4.3 Road ITS Electrical Power Source Performance Estimation Technique

Operation of road traffic signals and their monitoring systems is obviously very dependent on the availability of electrical energy. The use of backup power supply systems on road ITS also needs supply time estimation technique, in order to prioritise traffic signal junctions, to prevent possible traffic congestion.

In case of traffic signals reactive maintenance in a place like CoJ, related ITS must be able to give highly reliable projected performance of backup power systems with reference to traffic



signal timing plan per junction. The following is the block diagram of connected properties of integrated road ITS.

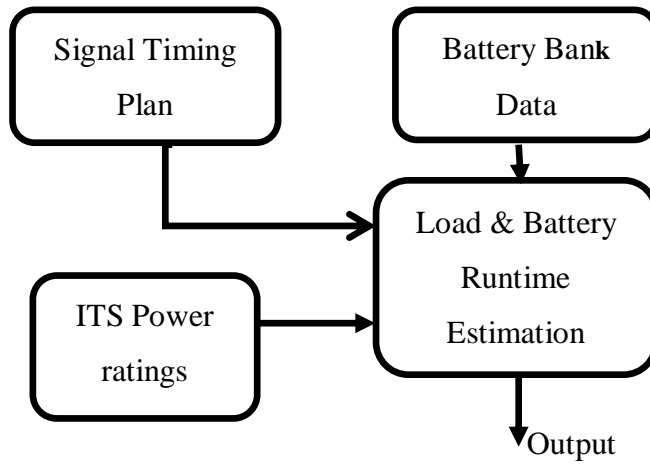

Figure 29: Integrated road ITS connected properties.

From Figure 29, it can be deduced that assessment is done based on three data sources, being signal timing plan, ITS power ratings and battery bank data. The grid supply status serves as the backup performance prediction trigger.

It is assumed that the power consumption ratings of traffic signal LED lights and other parts of ITS, are obtained from manufacturers. The prediction principle is based on the basic algorithm, as shown in Figure 30:

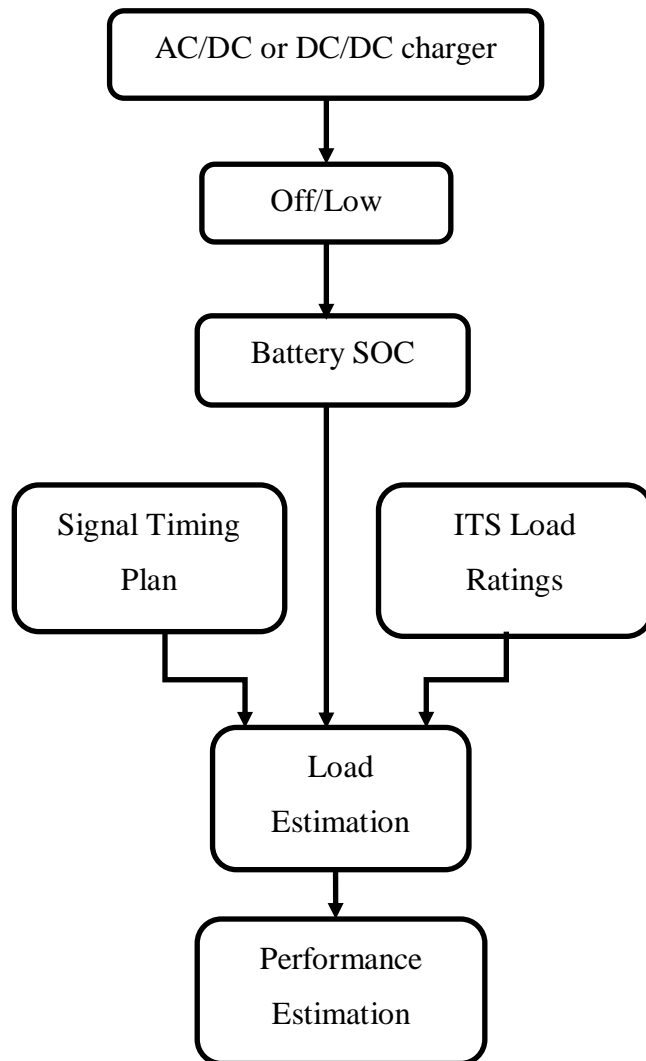

Figure 30: Battery performance or runtime estimation algorithm.

The battery temperature is indirectly considered as it nonlinearly affects the changes of SOC of the battery, thereby causing nonlinearity of the process.

#### 4.3.1 Battery State-of-Charge Estimation

This research concurs with Feng *et al.* (2013) that the charge build-up in the battery results in the increase in terminal voltage or electrical force. It can also be stated that a loss of charge from the battery results in the decrease in battery's electrical force. In other words, when the battery is discharged, the terminal voltage drops Sato *et al.* (2002). Terminal voltage does not exactly determine the state of charge, without considering the amount of current stored. Therefore, it is proposed that the available voltage should be considered as a factor of

determination of SOC, with reference to maximum stored current as counted. Voltage inference coulomb counting (VICC) method is used as it takes into account, other effects, like temperature without thorough temperature measurements.

SOC is therefore defined by (12) below.

$$SOC = Q_r \left( \frac{V_r - V_{co}}{V_{fr} - V_{co}} \right) \quad (12)$$

where,

- $Q_r$  is the remaining charge
- $V_r$  is the remaining battery voltage
- $V_{co}$  is the cut-off voltage
- $V_{fr}$  is the full reference battery voltage

and

$$Q = It \quad (13)$$

for

- $Q$  is the charge
- $I$  is the charge current
- $t$  is time

From (12), it can be deduced that the remaining charge is coulomb counting based, elaborated by (14):

$$Q_r = Q_{fr} + Q_{add} - Q_d \quad (14)$$

where

- $Q_{fr}$  is full reference charge
- $Q_{add}$  is added charge
- $Q_d$  is the discharged capacity

SoC and other charges (Q) are expressed in Ampere hour (Ah). From (13), time should be counted in seconds. It is proper to do so to accommodate frequent charge and discharge as they probably take place over different periods of time. The remaining battery charge is fundamentally considered for an hour of delivery.

When new fully charged battery is used for the first time, the assumption is that the available charge is equal to the full reference charge, based on the rated capacity. Therefore, (12) gives the correct estimating technique and assurance.

In addition, it can also be deduced that the true storage capacity or state of health (SOH) of the battery can be expressed as the ratio between full reference charge and rated full charge capacity. The formula below elaborates:

$$SOH = \left( \frac{Q_{fr}}{Q_{rated}} \right) * 100\% \quad (15)$$

(15) is also related to the state-of-health (SOH) expression presented by Williard *et al.* (2001). Therefore, it can be used to determine the quality of the battery. Figure 31 below is the basic battery measurement setup.

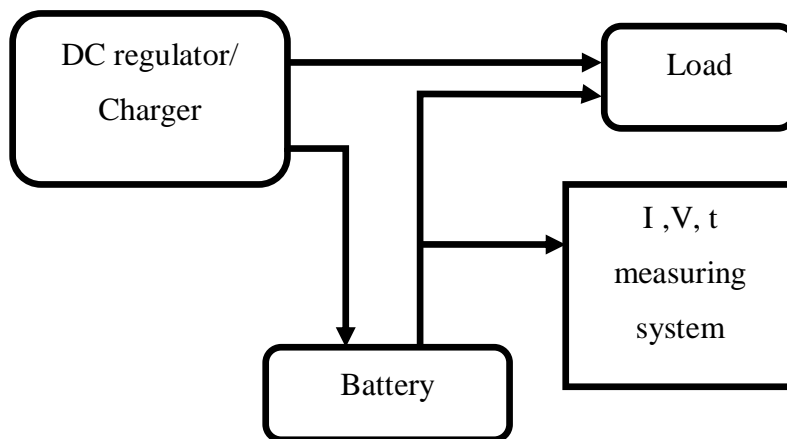

Figure 31: Basic battery measurement setup

Another schematic measurement setup done by Leksono *et al.* (2013) can be used with focus on 48V battery bank constructed for traffic signals.

#### 4.3.2 Load Prediction

From Figure 30, it is deduced that load estimation is dependent on battery state of charge, as point of reference. This gives a limitation in the data correlation, especially in fixed traffic signal timing plan, which is the case with reference to CoJ. Therefore, the estimated load consumption at nominal voltage should be equivalent to the battery state of charge.

The additive model is then used to sum up the equivalent load, linked to the signal timing plan and with reference to the nominal battery voltage. In this research, 48Vdc is considered as nominal battery voltage. Of course, there are phases to be considered for fixed timing plan, which is an important aspect of this research as applicable as it is in the CoJ.

It should be noted though, that the stored battery energy can be finished before a phase or cycle gets completed. Therefore, the stage load must be taken into consideration for the additive calculations to yield well estimated load. The formula to be used is as follows:

$$L_t = C_l * C_c \quad (16)$$

where,

$$C_l = L_{tcu} * C_t + n_p t_p L_p + n_{SL} SL_n \quad (17)$$

and

$$SL = n_3 t_3 L_3 + n_{turn} t_{turn} L_{turn} \quad (18)$$

where,

SL is signal light load

$L_t$  is total load

$L_{tcu}$  is TCU load

$L_p$  is pedestrian head load

$C_t$  is cycle time in seconds

$C_l$  is cycle load in Ah

$C_c$  is cycle count

$L_3$  is 3-light head load

$L_{turn}$  is turning light load

$n$  is quantity of the specific light head

$t$  is time for specific light head

It should be noted that SL can be an L3 or L5, depending on the combination.

### 4.3.3 Battery Runtime Prediction

This is the method of estimating battery runtime against the estimated or projected load at battery nominal voltage. Obviously, the dependence between the two aspects is the main factor to be considered. The linearity and non-linearity of inputs as products and sums of other inputs definitely require some intelligence techniques to compute the battery runtime, with reference to (12, 13, 14, 16, 17, and 18). It can be deduced in this case that a multiplicative model has to be applied to predict the battery runtime. Therefore, the following formula should be used for computation:

$$T_t = K_t * SOC * C_t * C_l^{-1} hr \quad (19)$$

where, time constant,  $K_t = 2.7778 * 10^{-4} h s^{-1}$   
and  $T_t$  is the runtime

### 4.4 TCU and LED Lights Compatibility

It is important for the TCU to operate effectively without feedback from LED lights. It still cannot be assumed that the use of battery solves compatibility problems. DC power distribution takes place through lamp drive cards embedded or flexibly mounted in the TCU. Therefore, some biasing is required to ensure robustness in traffic signal control.

DC lamp drive cards will need additional biased switching in control of current to and from the TCU and LED light, respectively. The basic circuitry may look like Figure 32.

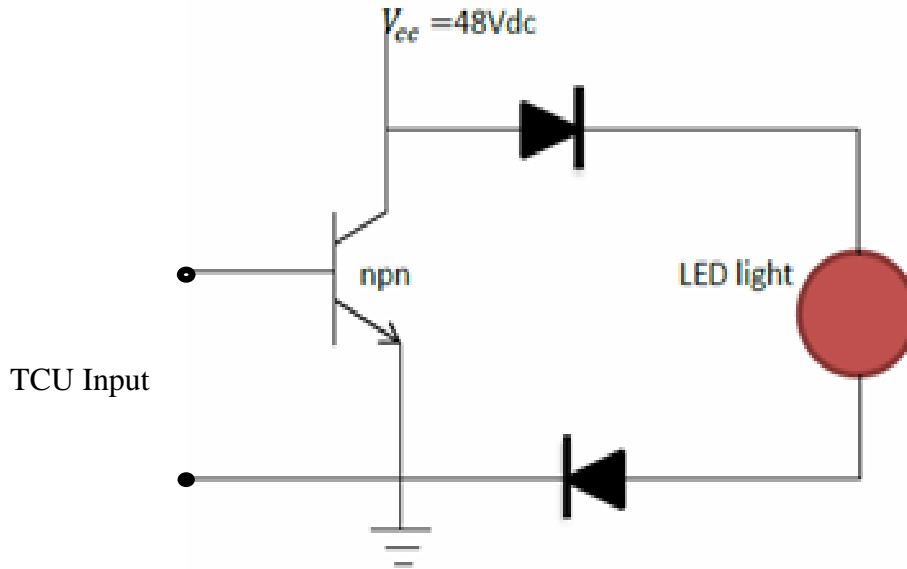
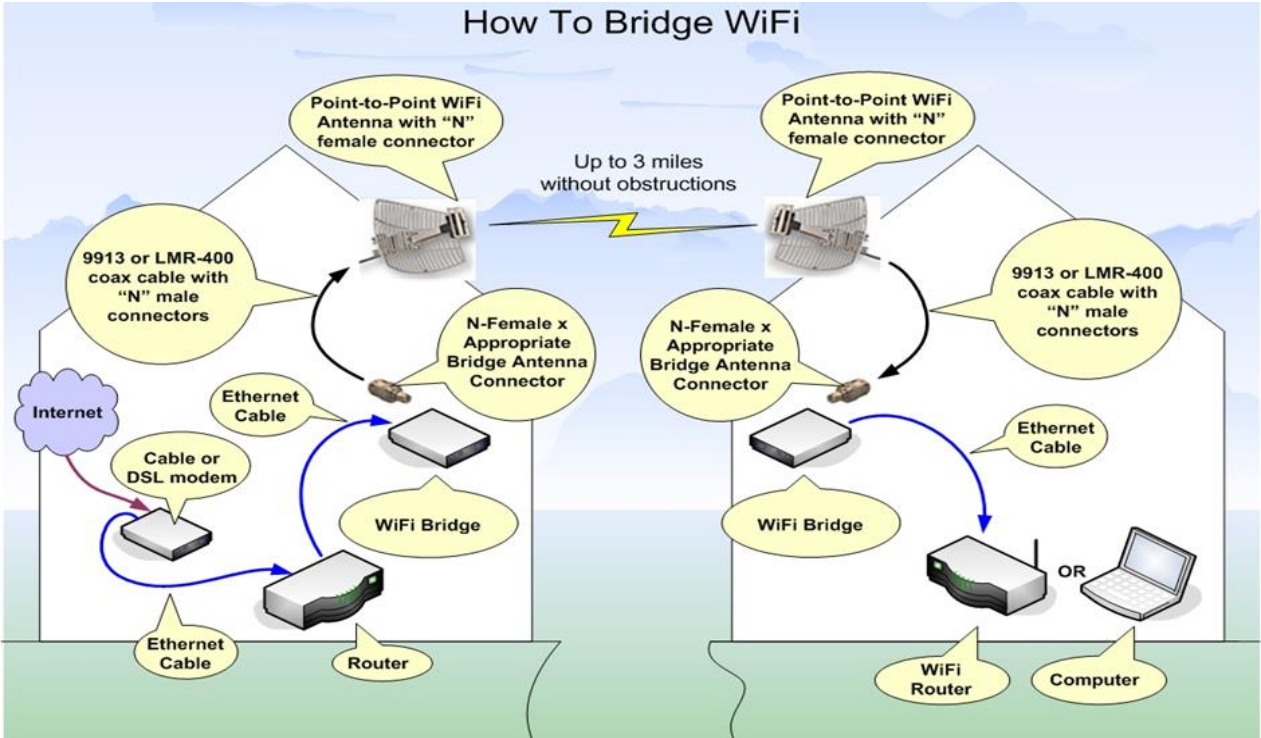

Figure 32: Basic biased switching circuitry.

Figure 32 ensures that there is no feedback from LED light to TCU. It also ensures that the frequency generated from both devices is clamped to allow continuous DC power distribution. The diodes may be seen as forming the matching element in DC traffic control operations

#### 4.5 Remote Monitoring Network

Further to the advantages of packet switching communication network, over circuit switching, long-range secure Wi-Fi and GPRS networks have been considered in this research, due to implementation simplicity over fiber network. It can also be stated, otherwise, that ITS should have its dedicated private network, which is simple to implement and maintain. Such an idea leaves fiber, especially in the CBD area, and Wi-Fi networks being ideal, avoiding the dependence on mobile internet service provider (ISP). For the purpose of this research, Wi-Fi and GPRS implementations are executed. Figure 33 shows examples of long range Wi-Fi and GPRS architectures, obtained from Countrymile Wi-Fi and Phoenixcontact, respectively.



(a) Wi-Fi

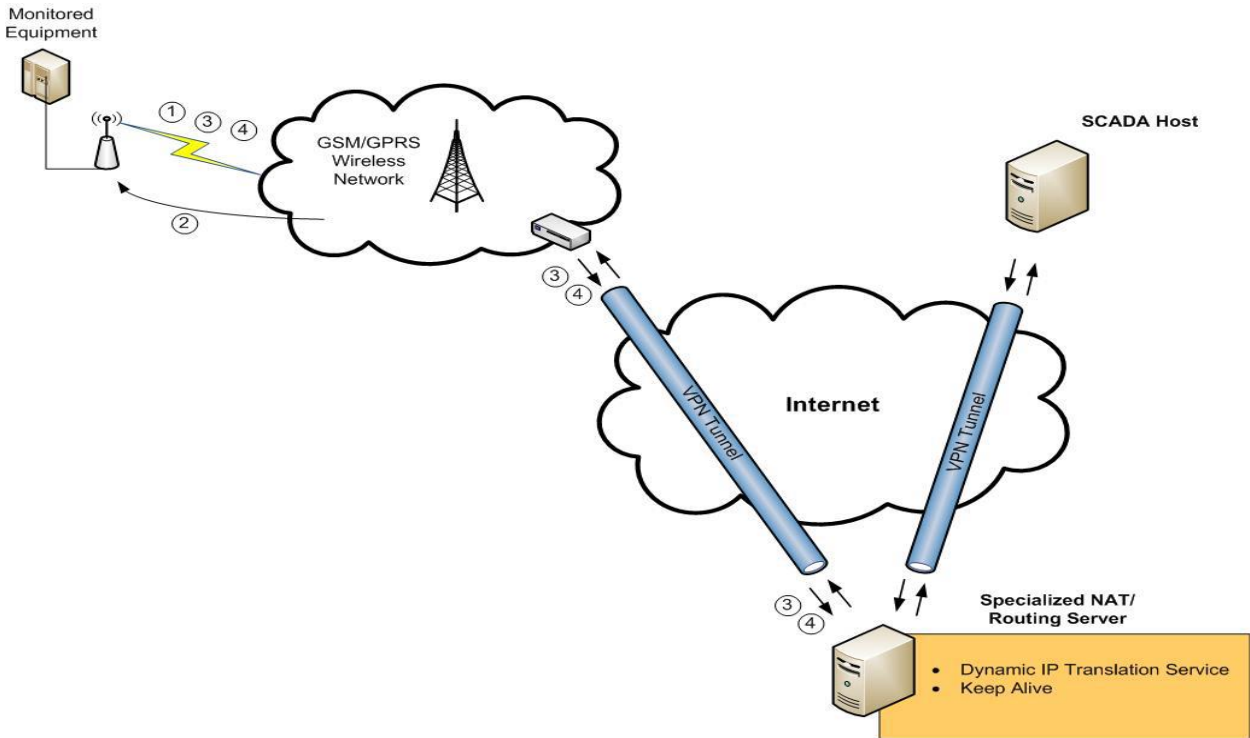

(b) GPRS

Figure 33: Communication network architectures.



From Figure 33(a), the Wi-Fi network is boosted for long range connectivity, with point-to-point antennae. In addition, the internet line can be used when automated SMSs are to be sent to the dedicated mobile phones. On the other hand, from Figure 33(b), virtual static internet protocol (VSIP) is set up for GPRS network.

## 4.6 Conclusion

Road ITS challenges continue to show that there is a need for further improvement than just traffic signal and traditional maintenance culture. Nowadays drivers have high expectations about traffic signals operations, as opposed to Mannering *et al.* (2009:228), who stated that from a driver's perspective, a traffic signal is just a collection of light emitting devices [usually incandescent bulbs or light-emitting diodes (LEDs)] and lenses that are housed in cases of various configurations (referred to as heads) whose purpose is to display red, yellow and green full circles and/or arrows.

The following are also key, in this research:

1. Energy efficiency modeling is proposed to increase system reliability for road traffic mobility. Intersection optimization technique by using traffic signals should consider such models important, for sustainability and elimination of maintenance uncertainties. Double energy conversion and addition of abnormal loads decrease the expected autonomy of backup power storage, and this research discourages such methods.
2. Junction layout should be considered during load planning and estimation.
3. The complexity of extracting and disseminating advanced road transport related information calls for application of artificial intelligence methods.
4. The need for automated simultaneous multiple traffic junction real-time monitoring and control calls for real-time data communication for effective reactive maintenance.

## 5. Implementation and analysis of energy efficient roads ITS

### 5.1 Introduction

Data collection was done on selected battery bank, and traffic signal timing plan. MATLAB/Simulink has been used to get the estimated battery SOC, traffic signal equivalent load and battery runtime, for DC operated traffic signal. The stage movement plan is used for clarity based on the sample intersection layout, designed according to SARTSM. The stage movement represents the traffic signal operational sequence that controls vehicle movements at a junction.

Tru-Traffic software has been used in assessing the reliability of roads network, in terms of traffic flow efficiency.

Different sites have been selected for communication network pilot project. Wi-Fi and GPRS networks have been tested to compare the operation of circuit and packet switching networks.

### 5.2 Information collection

Figures 35, 36 and 37 together with table IV and V show how the signals system at Figure 34 will operate. It can be seen from Figure 34, where traffic signal heads are identified as S1 and S8, where

S1 is 3-light head, and

S8 is 5-light head (of right turning)

Figure 35 shows cycle stages as P1 and P2 representing pedestrian lights on their specific roadsides. V1A is vehicle one-way. V2A, V2B represent vehicles in opposite directions.

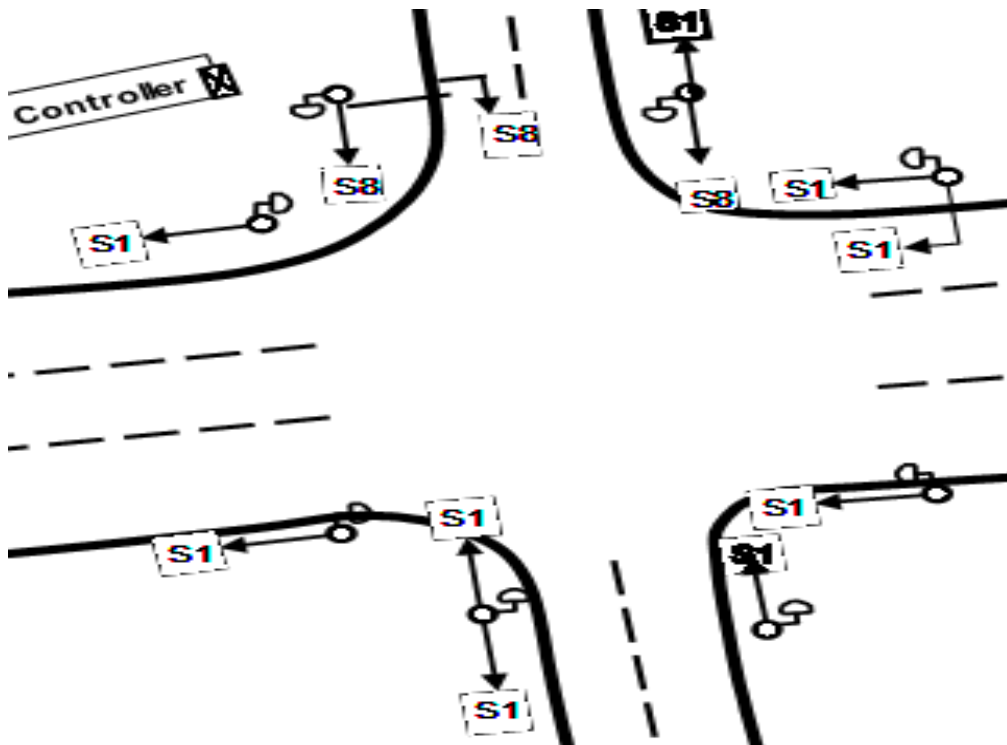

Figure 34: Sample junction layout.

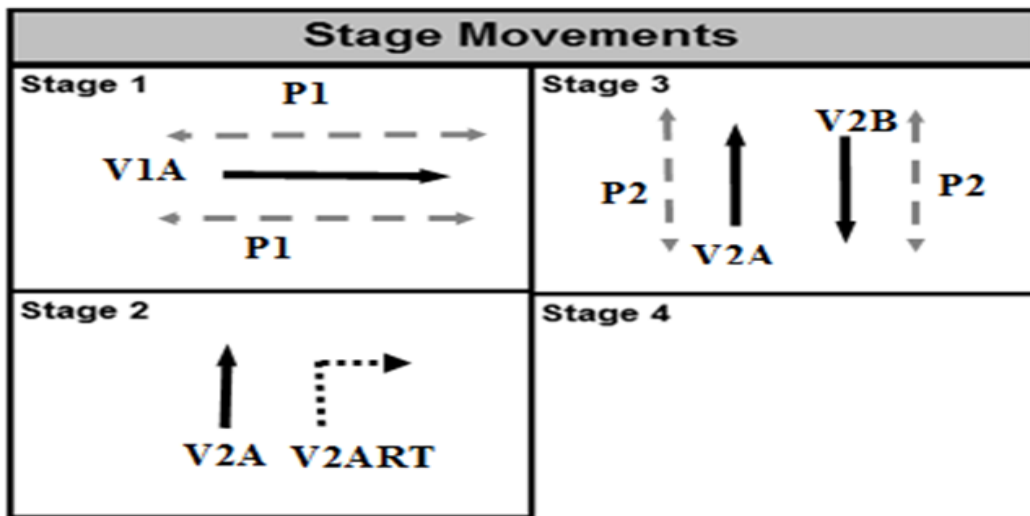

Figure 35: Stage movements plan.

Table IV: AM & PM peak cycle timetable

Stage	Start	Gr	Fred	FIGr	Ext	Yel	AR	Total
V1A	0	45				3	2	50
V2A	50	35				3	2	40
V2ART	50			8		3	2	13
V2B	63	22				3	2	27
P1	0	7	10					17
P2	63	7	15					22
<b>Cycle</b>								<b>90</b>
<b>AM period</b>	<b>Week days: 06:00-09:00    Weeked: 06:00-09:00</b>							
<b>PM time</b>	<b>Week days: 15:00-19:00    Weekend: 15:00-19:00</b>							

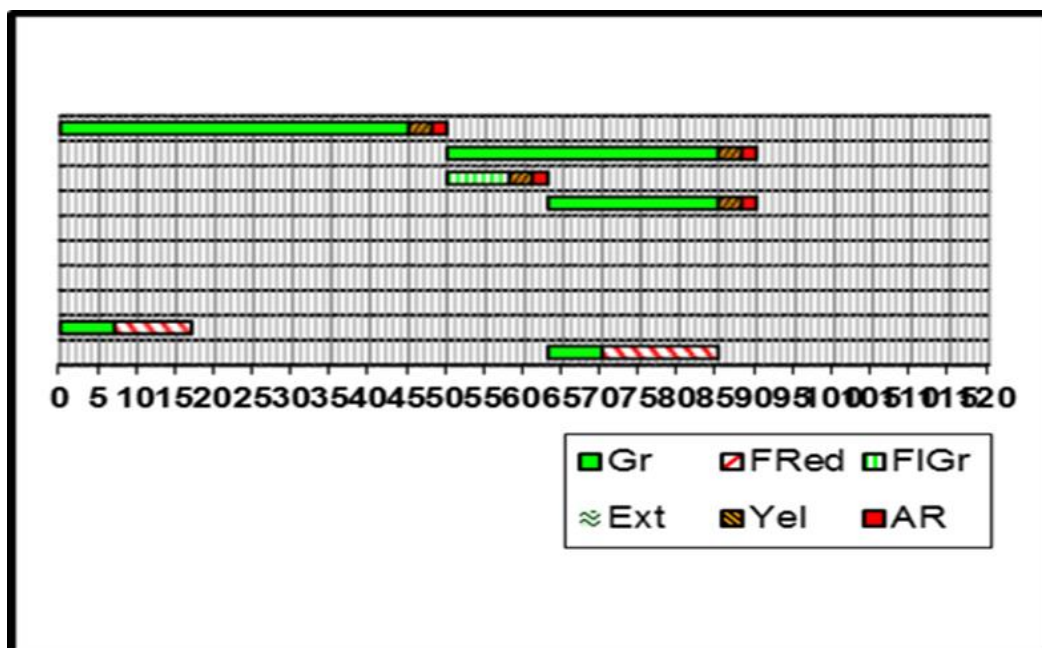

Figure 36: AM & PM fixed timing plan.

Table V: Off-peak cycle timetable

Stage	Start	Gr	Fred	FIGr	Ext	Yel	AR	Total
V1A	0	30				3	2	35
V2A	35	30				3	2	35
V2ART	35			6		3	2	11
V2B	46	19				3	2	24
P1	0	7	10					17
P2	46	4	15					19
<b>Cycle</b>								<b>70</b>
<b>Off peak time</b>	<b>Weekday: 09:00 - 15:00, 19:00 - 24:00, 00:00 - 06:00</b> <b>Saturdays &amp; Sundays: 00:00-24:00</b>							

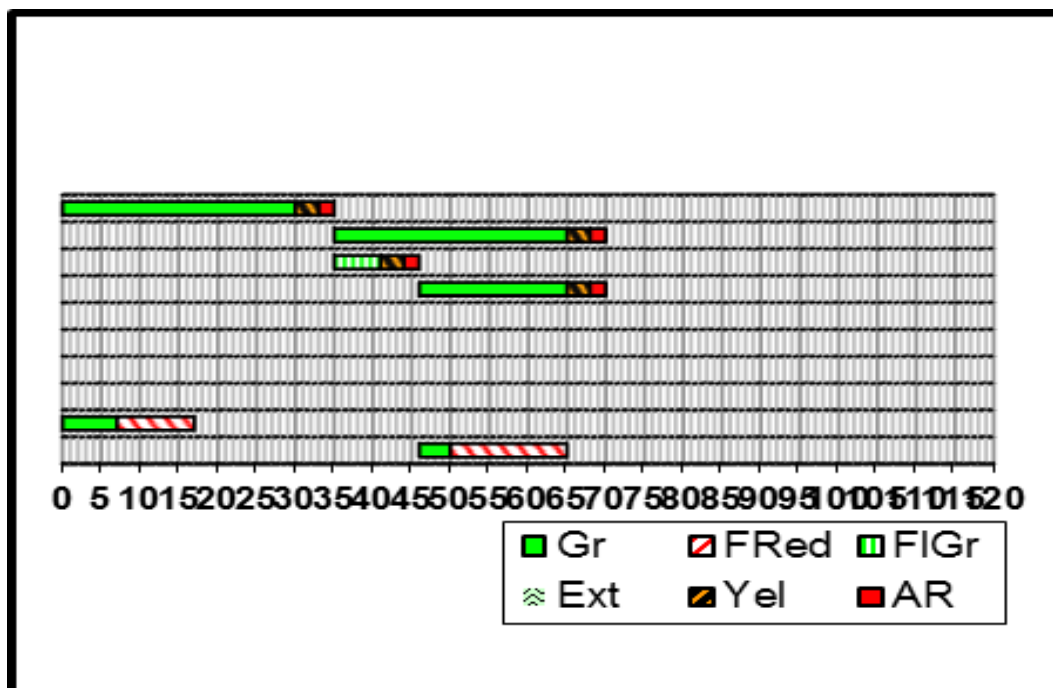

Figure 37: Off-peak fixed timing plan.

From the cycle timetables and timing plans, signal times are explained as follows:

Gr is green time

FRed is flashing red time

FlGr is flashing green time

Yel is yellow time

AR is all red time

Table VI below shows weight data per cycle, for system training, to estimate the equivalent load in Watt-hour (Wh), against battery state-of-charge. The variables' times converted to hours and their quantities are used to derive the weight data, with reference to (17) and (18).

Table VI: Traffic control cycle weight data comparison

Input	Cycle	
	70 seconds	90 seconds
$L_{tcu}$	0.019	0.025
$L_3$	0.233	0.300
$L_p$	0.156	0.200
$L_{turn}$	0.009	0.011

Therefore, the cycle loads training expression for the selected junction can be written as follows:

For the case of 70sec cycle:

$$C_l = 0.0019L_{tcu} + 0.233L_3 + 0.156L_p + 0.009L_{turn}$$

For the case of 90sec cycle:

$$C_l = 0.025L_{tcu} + 0.3L_3 + 0.2L_p + 0.011L_{turn}$$

### 5.3 Battery SOC and Runtime Estimation

Tables VII and VIII show the data collected on used and randomly selected battery bank. The expected charge is based on the percentage of the charge capacity rating. A Discharge-Charge-Discharge (D-C-D) process has been conducted on the used 48V battery bank, to get  $Q_{fr}$  on Table V.  $Q_{fr}$  and  $Q_{add}$  are respective cumulative values before the next full charge cycle.

Table VII: 48V battery data

Percentage (%)	Voltage (V)	Expected Charge (Ah)
100	51.13	102 (rated)
90	50.06	91.8
80	50.11	81.6
70	49.60	71.4
60	49.09	61.2
50	48.59	51
40	48.08	40.8
30	47.57	30.6
20	47.06	20.4
10	46.55	10.2
0	46.04	0

Table VIII: Battery charge cycle data

Measurement	Result
Floating Voltage	54.5V
$Q_{fr}$	95Ah
$Q_d @ 5.6A$	57.6Ah
$Q_{add} @ 10A$	54Ah
$V_r$	49.65V
$V_{fr}$	51.13
$V_{co}$	46.04

From (14),

$$Q_r = 95 + 54 - 57.6 = 91.4Ah$$

However, from (12),

$$SOC = \frac{91.4(49.65 - 46.04)}{51.13 - 46.04} = 64.82Ah$$

Figure 38 shows the estimated and actual runtime and curves from MATLAB/Simulink, at off-peak and peak periods, from 10:00 and 15:00 respectively. TCU and LED light module consumptions ratings used are 65W and 10W respectively, as the variable input values. A decrease in input variable power ratings, depending on the manufacturer's product power rating, will increase the battery runtime, thereby increasing the efficiency of the battery bank. It should also be noted that the estimated runtime determines the reliability factor about the battery bank charge, when the primary energy source is off.



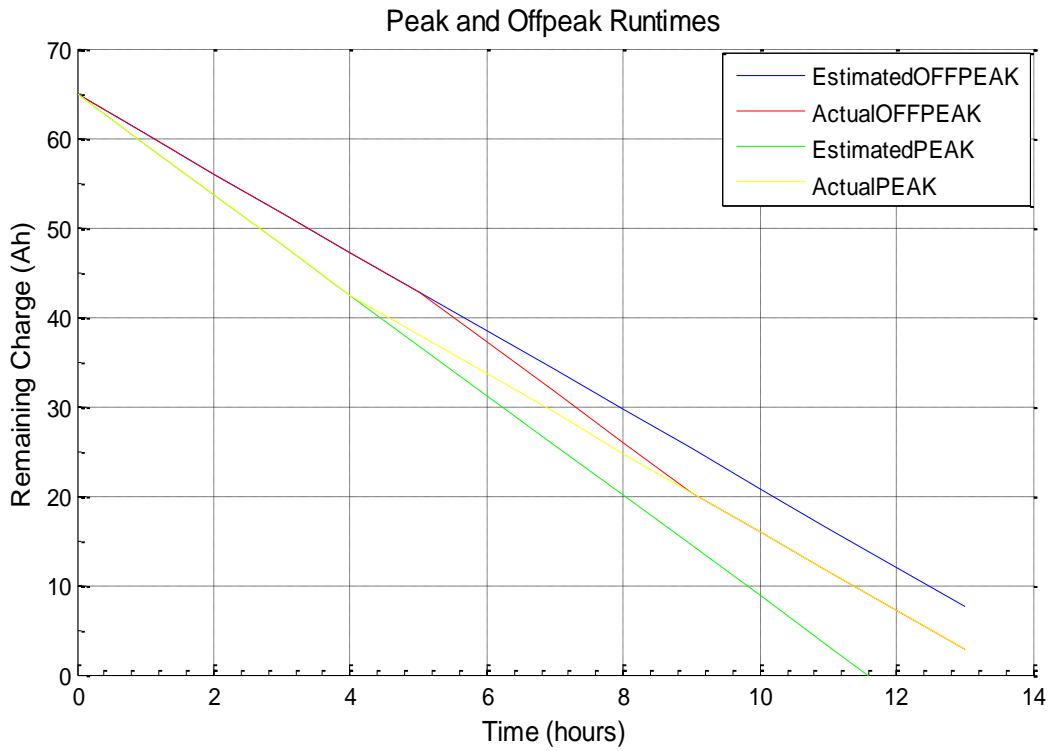

(a) Without reserved capacity

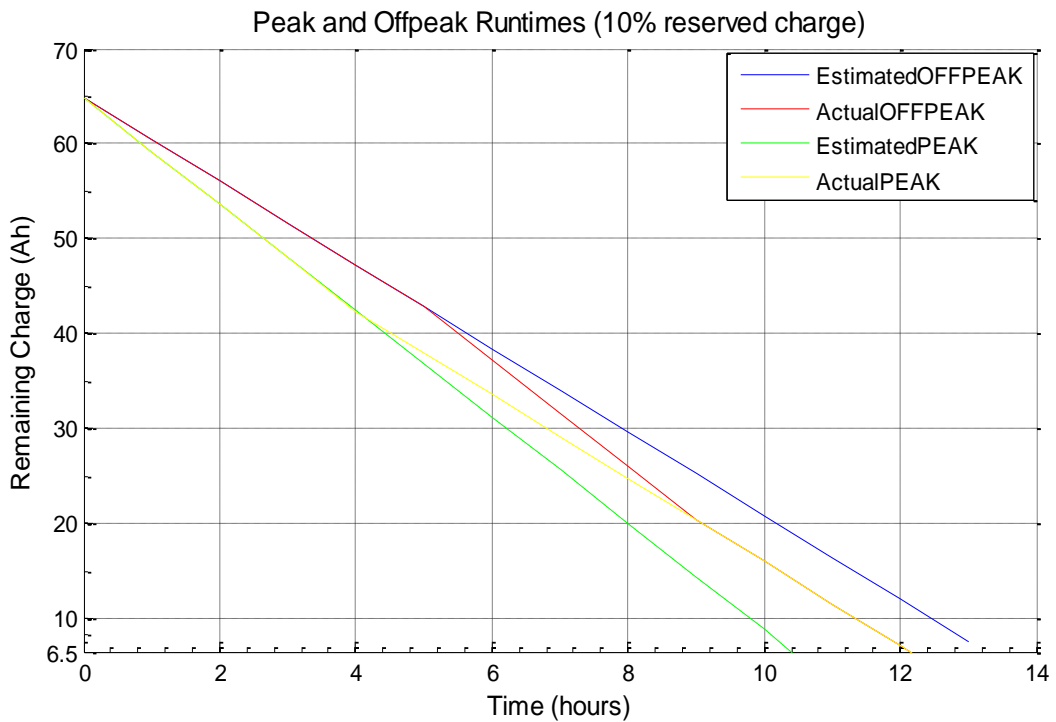

(b) With 10% capacity reserved

Figure 38: Remaining 64.82Ah runtime.

From Figure 38, it can be noticed that the traffic control system consumes more energy in peak than off-peak periods. The timing plans dictate the consumption variables and the training data thereof.

The estimated runtime is projected on the basis of the consumption variables of the period of estimation, against the available battery charge of 64.82Ah. The actual runtime is based on the true consumption, during both periods and the times of experiment.

#### 5.4 Communication network

In a city like CoJ, it is important to have high sites for Wi-Fi implementation, which should accommodate base transceiver station (BTS). This is to avoid signal obstruction of multiple connected sites. One can also refer to the city of Boulder, Colorado, like Kotwal *et al.* (2013), on replacing its T1 phone lines with private wireless technology that allows coordination of traffic signals from a central location, for the benefits of this new technology are remote signal monitoring, increased coverage areas and reduced cost of operations and maintenance. Apart from reliability of communication between system components, the weaknesses of wireless control include limited transmission distance and bandwidth. Therefore, in addition to Figure 33(a) as it is, the setup should resemble the block diagram in Figure 39, with one in-station device connected to multiple junction outstations.

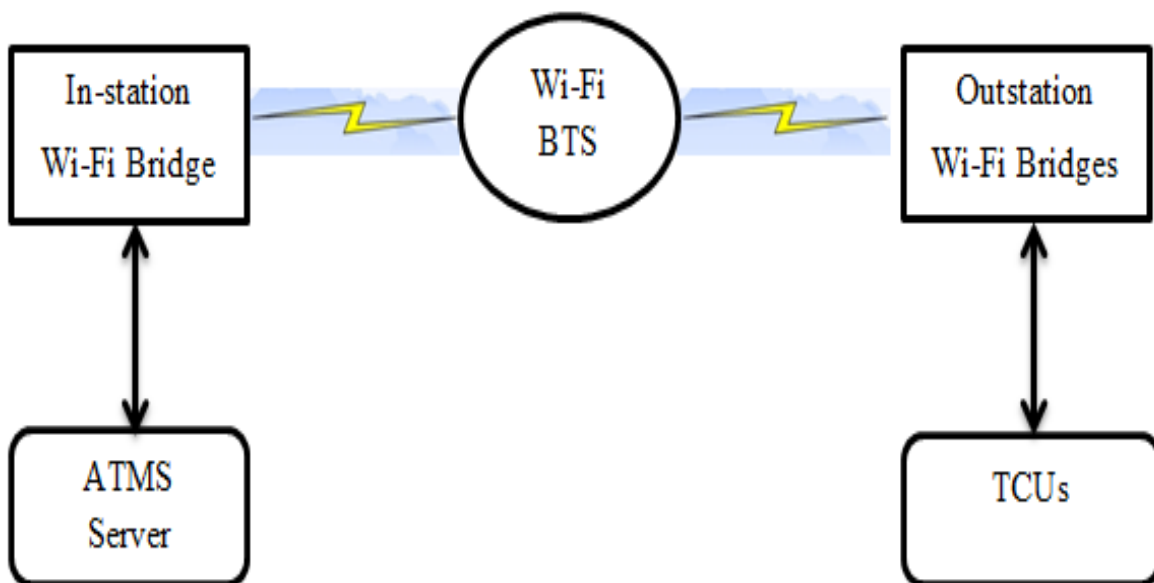

Figure 39: CoJ applicable Wi-Fi setup block diagram.

The general idea of real time information transmission in ITS revolves around continuous connectivity with good network response time, with sufficient bandwidth. Appendix A shows some results of scanned Wi-Fi frequencies, with 5755MHz and 5845MHz as the frequency of operation for the tested communication networks.

### 5.5 Road network reliability assessment

The assessment involves scenarios around impact of ITS components and traffic signal coordination. The components considered are: electrical power and communication network. Traffic signal coordination gives assurance to both TMC and the public, in terms of road mobility.

The assurance on ITS to the TMC is given through SCADA system. From all system tests conducted, the information obtained on SCADA system, from the traffic signal junction, can be considered when both power and communication systems are functioning effectively. When one system becomes unreliable, the whole ITS cannot be reliable to the TMC. Table VI has been developed in the process of component assessment at the traffic signal junction

Table IX: ITS component assessment on SCADA

<b>Output group</b>	<b>Fundamental components</b>		<b>Reliability</b>
	<b>Power</b>	<b>Communication system</b>	
0	OFF	OFF	Not reliable
1	OFF	ON	Not reliable
2	ON	OFF	Not reliable
3	ON	ON	Reliable

Consecutive intersections have been selected from Booyens road, as one of the arterial routes in the CoJ, for signals coordination simulation. The peak signal plan data in Table X has been used when dealing with synchronization. The Tru-Traffic software has been used for

simulation. The aim is to show the impact of well synchronized and interrupted road network. Figure 40 and 41 show the road network on the map and simulation results respectively.

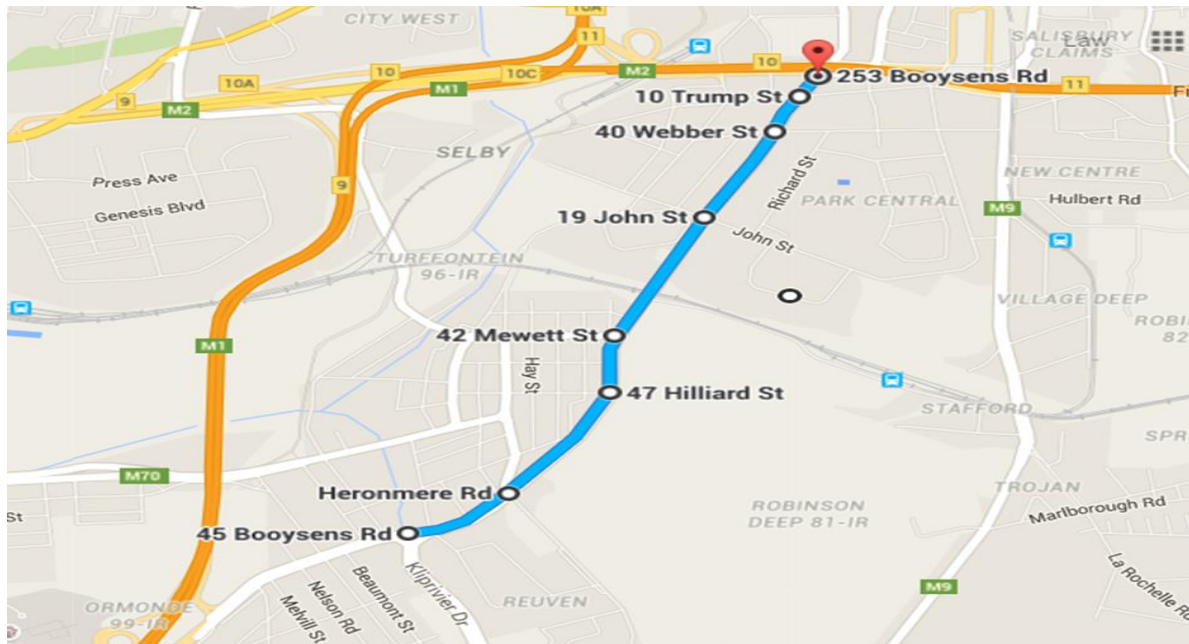
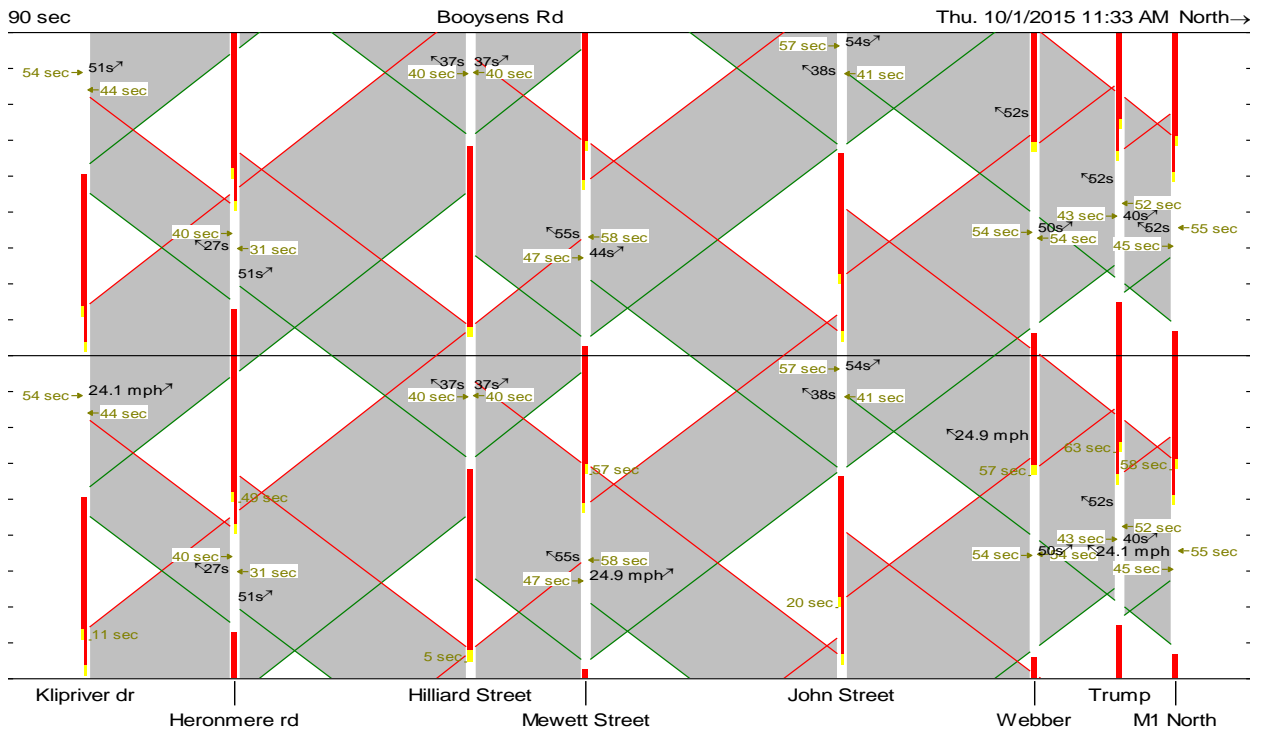

Figure 40: A map showing Booyensens road and its selected junctions

Table X below shows the collected data about each junction. The green time data has been extracted from the latest versions of signal timing plans.

Table X: Booyensens road network junctions data

Street name (from reference)	Distance from previous street (meters)	Speed limit (km/h)	Arterial Green time (Seconds), At 90seconds cycle time		No. of lanes (per direction)
			North	South	
Klip river str.	0	60	54	44	3
Heronmere str.	350	60	40	31	3
Hilliard str.	550	60	40	40	3
Mewett str.	270	60	47	58	3
John str.	600	60	57	41	3
Webber str.	450	60	54	54	3
Trump str.	200	60	43	52	3
M1 north	130	60	45	55	3



(a) Booyens road traffic flow with junctions' traffic signals not working at Hilliard and John streets

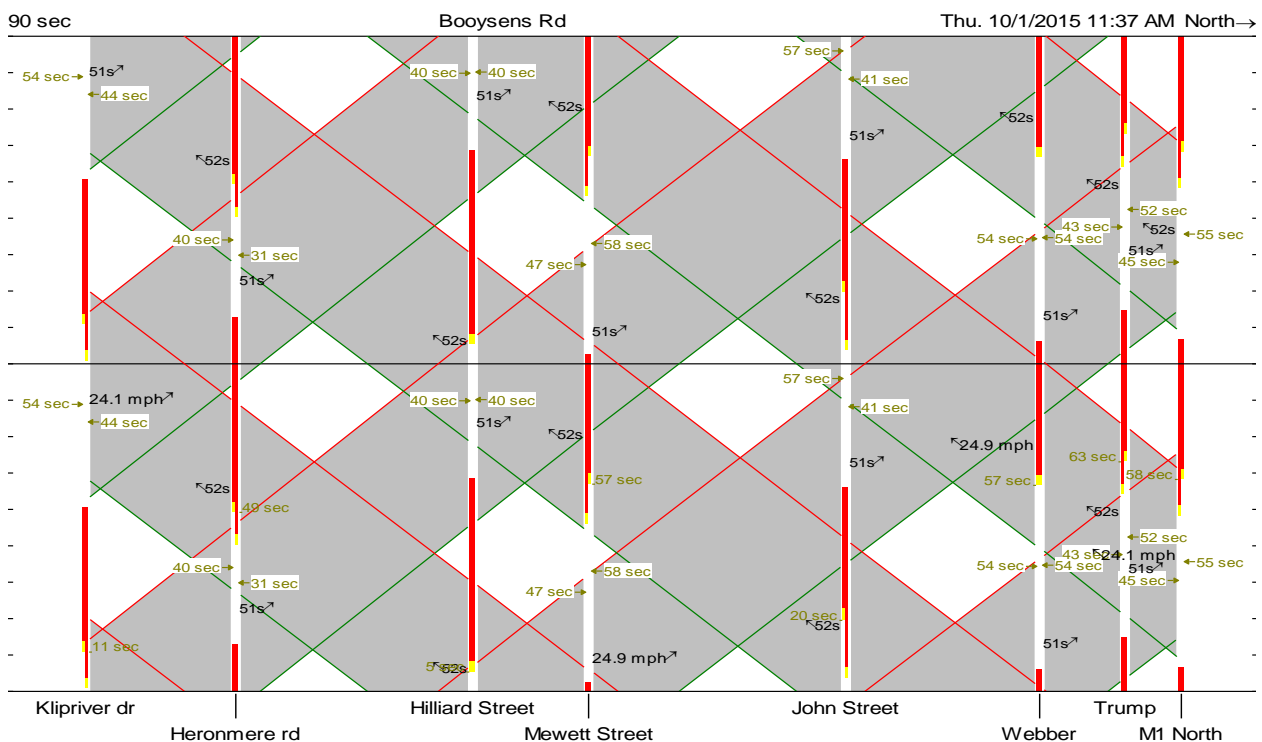

(b) Booyens road fine-tuned synchronized road network functioning well with effective dc power systems

Figure 41: Booyens road traffic flow

From Figure 41(a), Booyens junctions at Hilliard and John streets traffic signals are not working, due to systematic faults. Such interruption is causing road network inefficiencies in terms of mobility, with reference to Klip river as the point of departure, by causing delays at other junctions too.

Depending on the vehicle queue length and occupancy per lane per direction, some vehicles may also end up stopping at functional junctions, due to delays, thereby moving from synchronization. The same Figure 41(a) shows the same traffic flow being affected at the junction of Mewett street and other subsequent junctions in north and south directions, respectively. In addition, systematic faults along different routes can contribute towards mobility inefficiencies, even where systems are working

Figure 41(b) shows simulation results of the seamless and well synchronized road network that operates according to traffic signal plan and synchronization settings. The results are dependent on the effective and efficient power supply systems modeling and configuration, as shown in section 4 of this dissertation.

Reliability of communication network is based on the connectivity and response speed. Wi-Fi network test results are shown in Figure 42 to 45. GPRS results are shown in Figure 46 and 47.







```
C:\Windows\system32\cmd.exe
C:\Users\JKR>ping 10.4.43.83 -t

Pinging 10.4.43.83 with 32 bytes of data:
Reply from 10.4.43.83: bytes=32 time=6ms TTL=64
Reply from 10.4.43.83: bytes=32 time=6ms TTL=64
Reply from 10.4.43.83: bytes=32 time=6ms TTL=64
Reply from 10.4.43.83: bytes=32 time=6ms TTL=64
Reply from 10.4.43.83: bytes=32 time=6ms TTL=64
Reply from 10.4.43.83: bytes=32 time=7ms TTL=64
Reply from 10.4.43.83: bytes=32 time=6ms TTL=64
Reply from 10.4.43.83: bytes=32 time=6ms TTL=64
Reply from 10.4.43.83: bytes=32 time=6ms TTL=64
Reply from 10.4.43.83: bytes=32 time=7ms TTL=64
Reply from 10.4.43.83: bytes=32 time=6ms TTL=64
Reply from 10.4.43.83: bytes=32 time=6ms TTL=64
Reply from 10.4.43.83: bytes=32 time=8ms TTL=64

Ping statistics for 10.4.43.83:
    Packets: Sent = 13, Received = 13, Lost = 0 (0% loss)
  Approximate round trip times in milliseconds:
    Minimum = 6ms, Maximum = 8ms, Average = 6ms
Control-C
```

Figure 44: Wi-Fi with 6-7ms response time

```
en C:\Windows\system32\cmd.exe
C:\Users\JKR>ping 10.4.43.84 -t
Pinging 10.4.43.84 with 32 bytes of data:
Reply from 10.4.43.84: bytes=32 time=16ms TTL=64
Reply from 10.4.43.84: bytes=32 time=48ms TTL=64
Reply from 10.4.43.84: bytes=32 time=21ms TTL=64
Reply from 10.4.43.84: bytes=32 time=13ms TTL=64
Reply from 10.4.43.84: bytes=32 time=13ms TTL=64
Reply from 10.4.43.84: bytes=32 time=17ms TTL=64
Reply from 10.4.43.84: bytes=32 time=12ms TTL=64
Reply from 10.4.43.84: bytes=32 time=35ms TTL=64
Reply from 10.4.43.84: bytes=32 time=28ms TTL=64
Reply from 10.4.43.84: bytes=32 time=12ms TTL=64
Reply from 10.4.43.84: bytes=32 time=31ms TTL=64
Reply from 10.4.43.84: bytes=32 time=13ms TTL=64
Reply from 10.4.43.84: bytes=32 time=17ms TTL=64
Reply from 10.4.43.84: bytes=32 time=12ms TTL=64
Ping statistics for 10.4.43.84:
    Packets: Sent = 14, Received = 14, Lost = 0 (0% loss)
    Approximate round trip times in milliseconds:
    Minimum = 12ms, Maximum = 48ms, Average = 19ms
Control-C
```

Figure 45: Wi-Fi with 12-40ms response time

```
C:\Windows\system32\cmd.exe
C:\Windows\system32>ping 10.4.50.221 -t

Pinging 10.4.50.221 with 32 bytes of data:
Reply from 10.4.50.221: bytes=32 time=732ms TTL=57
Reply from 10.4.50.221: bytes=32 time=898ms TTL=57
Reply from 10.4.50.221: bytes=32 time=867ms TTL=57
Reply from 10.4.50.221: bytes=32 time=950ms TTL=57
Request timed out.
Reply from 10.4.50.221: bytes=32 time=1449ms TTL=57
Reply from 10.4.50.221: bytes=32 time=661ms TTL=57
Reply from 10.4.50.221: bytes=32 time=559ms TTL=57
Reply from 10.4.50.221: bytes=32 time=698ms TTL=57
Reply from 10.4.50.221: bytes=32 time=729ms TTL=57

Ping statistics for 10.4.50.221:
    Packets: Sent = 10, Received = 9, Lost = 1 (10% loss),
    Approximate round trip times in milli-seconds:
        Minimum = 559ms, Maximum = 1449ms, Average = 838ms
Control-C
C:\Windows\system32>_
```

Figure 46: GPRS with 559-1449ms response time

```
C:\Windows\system32\cmd.exe
C:\Windows\system32>ping 10.4.50.229 -t

Pinging 10.4.50.229 with 32 bytes of data:
Reply from 10.4.50.229: bytes=32 time=1673ms TTL=57
Reply from 10.4.50.229: bytes=32 time=525ms TTL=57
Reply from 10.4.50.229: bytes=32 time=614ms TTL=57
Reply from 10.4.50.229: bytes=32 time=581ms TTL=57
Reply from 10.4.50.229: bytes=32 time=648ms TTL=57
Reply from 10.4.50.229: bytes=32 time=770ms TTL=57
Reply from 10.4.50.229: bytes=32 time=571ms TTL=57

Ping statistics for 10.4.50.229:
    Packets: Sent = 7, Received = 7, Lost = 0 (0% loss),
    Approximate round trip times in milli-seconds:
        Minimum = 525ms, Maximum = 1673ms, Average = 768ms
Control-C
C:\Windows\system32>
```

Figure 47: GPRS with 525 - 1673ms response time

## 5.6 Results analysis

DC power distribution fulfills the elimination the effects of grid power instability, towards road ITS. In addition, only AC/DC power conversion takes place, where the main source is from the utility grid. When the main source is off, the battery bank automatically becomes the source of energy, without instabilities. This ensures optimum usage of stored energy, as no further DC/AC conversion has to take place, for it could lead to high current drawn, resulting in increase in temperature. The high temperature would be a sign that some stored energy is getting lost than used, in the process.

With reference to Table I and the experiments conducted, when using AC power distribution, with battery cutoff level at 10%, 60% of stored energy would be available on ideal line-interactive UPS of 67~70% efficiency. Therefore, 20% cutoff level would reduce to 54%, meaning that almost 50% goes to reserved and wasted energy collectively. It is noticed that DC implementation improves on systems compatibility as feedbacks are eliminated, which also eliminates the use of abnormal loads. This eventually reduces the cost of electrical energy supply and systems maintenance thereof.

Elimination of double conversion, therefore, leads to the elimination of DC/AC inverters. This subsequently relates to the reduction of systems costs per junction. With reference to Table I, pure sine wave inverters are highly expensive, compared to other parts of the backup systems. An estimated minimum cost of 40% of UPS, for example, goes to the inverter. Therefore, the implementation of the proposed power supply solution will save 40% of capital cost and the subsequent cost of maintenance or replacement, while improving the ITS reliability.

From SOC derived from Table V, in comparison with Table IV data, about 7% of battery rated storage quality or capacity is lost. The losses incurred during adaptive cumulative charge and discharge processes before the next full charge cycle, also have an effect on the battery SOC, resulting in 10.4% missing against the expected battery charge level. This may be caused by battery age or previous severe usage. Therefore, Voltage inference coulomb counting ensures accuracy by indirectly incorporating dynamic effects. Of course the battery

configuration also helps in eliminating other factors like high temperature as it helps in maintaining operational conditions.

As part of the SCADA system development, the integration with SOC assessment functionality will improve in extracting real-time information. It will improve in ITS maintenance decisions, with more assurance on information reliability. Figure 38 shows the close relationship between the estimated and actual battery runtimes, with the difference caused by changes in traffic signal time plan cycles. Surely, this is also dependent on the packet switching network implementation, as recommended in this research.

In addition to primary power source off-trigger, timing plan cycles also trigger and give training data for estimations. Therefore, AM-, PM- and OFF-Peak timing plans functionality triggers continuous SOC assessment, which further considers dynamic effects on accurate performance estimation. This can improve the accuracy of battery bank reliability assessment, periodically and daily.

From the communication network test results in figure 42 to 47, it can be deduced that packet switching brings simplicity in monitoring network connectivity. Wi-Fi shows good response time over GPRS, which is good for real-time information systems. This is probably because GPRS connectivity goes through internet Service Provider (ISP) link, whereas secure Wi-Fi connectivity belongs to JRA, with limited traffic as compared to ISP infrastructure.

The assessment of Wi-Fi network implementation has shown cost effectiveness, in the sense that there is no continuous rental cost associated with it, as ownership is with JRA. Ownership is better, for the network does not get shared with other parties, as it happens with ISPs. This helps in reducing the risk of not getting ITS functionality information, which can also put the lives of motorists and pedestrians in danger.

## 6. Conclusions and Future research

### 6.1 Conclusion

DC power distribution is the way to go in the CoJ, to eliminate systematic faults and maintenance uncertainties at traffic signal junctions. The effects of utility grid and backup systems inefficiencies can also be eliminated, with almost 100% of stored energy available.

With reference to experiential analysis, it can be concluded that 86% of persistent faults can be eliminated. It can further be concluded that the related maintenance cost thereof, will be eliminated.

Voltage inference coulomb counting perfectly determines the true battery SOC. It indirectly incorporates all dynamic factors that affect charge level accuracy. The models applied in this research can serve well in traffic signal load and operational runtime estimations. Traffic signal control software should include the integration of backup power supply performance application. This will contribute towards increasing certainty level to the TMC and in maintenance decisions.

Private packet switched network should be used to monitor and control all parts of road ITS. This ensures continuous ownership and maintenance independence from ISPs and cost reduction thereof. The assurance in real-time information also depends in such a complementary element of ITS. This can support reactive and preventative maintenance planning, effectively.

The implementation of DC systems should see the amendment of SARTSM section 25, to make sure that qualified Electronic Engineering Technicians take maintenance responsibilities of advanced ITS.

### 6.2 Future research

Future work can be done to improve the quality of traffic signal load prediction training data. The data should be dependent on the true and adaptive power consumption data collected per connected LED light module.

Since there has always been an interest in reducing power consumption, it will also be important to determine the true consumed energy, for the purpose of avoiding unstructured cost estimation. A hint can be given on the fact that some LED signal heads may be burnt, though others are working. Some LEDs of a module may be burnt too, while the module is deemed working. It can therefore be argued that the cost of consumed electrical energy cannot be the same, every month, but should be below the maximum expected cost. Therefore, it is important to have accurate power consumption measuring method or technique.

The same improvements can also help in fault detection per individual module, while bringing more assurance to the maintenance team. From this research, it can be deduced that ITS functionality improvement, attached to maintenance cost reduction, is possible at very low cost, as part of systems maintenance.



## List of references

1. City of Johannesburg. 29 September 2011. Joburg chooses solar power.  
[http://www.joburg.org.za/index.php?option=com\\_content&view=article&id=7238:joburg-chooses-solar power&catid=131:transport&Itemid=213](http://www.joburg.org.za/index.php?option=com_content&view=article&id=7238:joburg-chooses-solar-power&catid=131:transport&Itemid=213)
2. Louis Pieterse, Alexander Ebert and Paul Ryan. 'Asset Management at City Power Johannesburg Enabled by ICT'. 22<sup>nd</sup> International Conference on Electricity Distribution. June 2013. pp. 1-4.
3. South African Road Traffic Sign Manual. April 2001. 3rd Edition. Traffic Signal Design. Volume 3.
4. Ned Mohan, Tore M. Undeland & William P. Robbins. 2003. Power Electronics. Converters, Applications and Design. John Wiley & Sons, Inc.
5. A.B. Cultura II and Z.M. Salameh. 2008. "Performance Evaluation of a Supercapacitor Module for Energy Storage Applications". IEEE Power and Energy Society Meeting. pp. 1-7.
6. Stefan Krauter. 2006. "Solar Electric Power Generation. Photovoltaic Energy Systems". The Netherlands: Springer.
7. Types of Uninterruptable Power Supply (UPS) Systems. [Online]. Available at: <http://www.thomasnet.com/articles/electrical-power-generation/ups-system-types>
8. Neil Rasmussen. The Different Types of UPS Systems. White paper 1, Revision 6. 2010. [Online]. Pp. 1-10. Available at: [http://m.softchoice.com/files/pdf/brands/apc/SADE-5TNM3Y\\_R6\\_EN.pdf](http://m.softchoice.com/files/pdf/brands/apc/SADE-5TNM3Y_R6_EN.pdf)
9. Hideaki Shiranaga and Shouhei Ogawa. "Development of ultra-low power consumption traffic signals with magnetic inversion method". 2012 ITSAP. pp. 1-8

10. Intelight. Intelight Cabinet Model 357 ITS v2.  
<http://intelight-its.com/product/cabinets/item/98-intelight-cabinet-model-357-its-v2.html>
  
11. K.Y Lee, Y.T. Cha and J.H. Park. February 1992. "Short-term load forecasting using an artificial neural network". Transaction on Power Systems. Vol. 7, No. 1, pp. 124 – 132
  
12. Caglan M. Aras, James J. Kurose, Douglas S. Reeves and Henning Schulzrinne. January 1994. "Real-time communication in packet-switched networks. Proceedings of IEEE". Vol. 82, No. 1, pp. 122 – 139
  
13. Fred L. Mannering, Scott S. Washburn & Walter P. Kilareski. 2009. "Principle of Highway Engineering and Traffic Analysis". Fourth edition. USA: John Wiley & Sons, Inc.
  
14. Intelligent transportation systems. [Online]. Available at:  
[http://en.wikipedia.org/wiki/Intelligent\\_transportation\\_system](http://en.wikipedia.org/wiki/Intelligent_transportation_system)
  
15. Intelligent Traffic Management Systems. [Online]. Available at:  
<http://edgeict.com/Intelligent%20Traffic%20Management%20Systems.html>
  
16. Renjian Feng, Shuai Zhao & Xiaodong Lu. 2013. "On-Line Estimation of Dynamic State-of-Charge for Lead Acid Battery Based on Fuzzy Logic". 2nd International Conference of Measurement, Information and Control. pp. 447-451.
  
17. Kesheng Wang. 2005. 'Applied computational intelligence in intelligent manufacturing systems'. Adelaide, S.A.
  
18. Michael Negnevitsky. 3rd Edition. 2011. 'Artificial intelligence: a guide to intelligent systems'. Harlow, England. Addison Wesley / Pearson.
  
19. Abe Shigeo. 1997. "Neural networks and fuzzy systems : theory and applications"  
 Boston : Kluwer Academic.

20. Mohamed Mohamoud Ismail & M.A. Moustafa Hassan. 2013. "The state of Charge Estimation for Rechargeable Batteries Based on Artificial neural network techniques". IEEE Control, decision and Information technologies (CoDIT). pp. 733-739.
21. C.H. Cai, D. Du & Z.Y. Liu. 2003. "Battery State-of-Charge Estimation Using Adaptive Neuro-Fuzzy Inference System (ANFIS)". The IEEE International Conference on Fuzzy Systems. Vol. 2. pp. 1068-1073.
22. W.X. Shen, C.C. Chan, E.W.C. Lo & K.T. Chau. June 2002. "Adaptive Neuro-Fuzzy Modeling of Battery Residual Capacity for Electric Vehicles". IEEE Transactions on Industrial Electronics. Vol. 49. No. 3. pp. 677-684.
23. Douglas Davey & Darryll Thomas. July 2000. "A Review of Selected South African Urban traffic Control Systems". South African Transport Conference.
24. I.N. Askerzade & Mustafa Mahmood. April 2010. "Control the Extension Time of Traffic Light in Single Junction by Using Fuzzy Logic". International Journal of Electrical & computer Sciences. Vol. 10. No. 2. pp. 48-55.
25. H.S. Goliya & Nitin Kimar Jain. 2012. "Synchronization of Traffic Signals. "A Case Study – Eastern Ring Road, Indore"". International Journal of Advanced Technology in Civil Engineering. Vol, 1. Issue 2. pp. 47-52.
26. City of Irvine. Traffic Signal Synchronization. [online]. Available at: <http://www.cityofirvine.org/signal-operations-maintenance/traffic-signal-synchronization>
27. Dr. Tom V. Mathew. August 2014. Transportation Systems Engineering: Vehicle Actuated Signals. Indian Institute of Technology Bombay. pp. 39.1-39.19. Available at: [http://www.civil.iitb.ac.in/tvm/1111\\_nptel/576\\_VAS/fancy.pdf](http://www.civil.iitb.ac.in/tvm/1111_nptel/576_VAS/fancy.pdf)
28. Carroll J. Messer & Ramanan V. Mageswara. August 1996. "Improved Traffic Signal Coordination Strategies for Actuated Control". Southwest Region University

Transportation Center. Available at:  
<http://library.ctr.utexas.edu/digitized/SWUTC/465110-1.pdf>

29. J. Duncan Glover & S. Mulukutla Sarma. 2002. 3rd Edition. "Power system analysis and design". Pacific Grove, California.
30. Tomas Markvart. 1994. "Solar Electricity". England: John Wiley & Sons Ltd.
31. Wikipedia. Ring Circuit. Available at: [http://en.wikipedia.org/wiki/Ring\\_circuit](http://en.wikipedia.org/wiki/Ring_circuit)
32. Rafal Weron. 2006. "Modeling and forecasting electricity load and prices". A Statistical Approach. England: John Wiley & Sons Ltd.
33. Hong Chen, Claudio A. Canizares and Ajit Singh. 2001. "ANN-based Short-Term Load Forecasting in Electricity Markets". IEEE Power Engineering Society Winter Meeting. [Online]. Vol. 2. pp. 411-415.
34. Martin Coleman, Chi Kwan Lee, Chunbo Zhu, William Gerard Hurley. October 2007. "State-of-charge Determination From EMF Voltage Estimation: Using Impedance, Terminal Voltage and Current for Lead-Acid and lithium-Ion Batteries". IEEE transactions on Industrial Electronics, vol 54, no. 5, pp. 2550-2557.
35. Shinya Sato & Atsuo Kawamura. 2002. "A New Estimation Method of State of Charge using Terminal Voltage and Internal Resistance for Lead Acid Battery". Power Conversion Conference. pp. 565-570.
36. Nick Williard, Wei He, Michael Osterman & Michael Pecht. "Improved SOH Estimation through Coulomb Counting". Center for Advanced Life Cycle Engineering. University of Maryland. 2001. pp. 1-11.
37. Edi Leksono, Irsyad Nashirul Haq, Muhammad Iqbal, FX Nugroho Soelami & IGN Merthayasa. 2013. "State of Charge (SoC) Estimation on LiFePO<sub>4</sub> Battery Module Using Coulomb Counting Methods with Modified Peukert". Joint International Conference on

Rural Information & Communication Technology and Electric-Vehicle Technology (rICT & ICeV-T). pp. 1-4.

38. Cisco Press Publications. "Cisco CCIE Fundamentals: Network Design and Case Studies". Available at: <http://www.cisco.com/cpress/cc/td/cpress/ccie/ndcs/index.htm>
39. Mehdi Modarressi, Hamid Sarbazi-Azad & Mohammad Arjomand. 2009. "A Hybrid Packet-Circuit Switched On-Chip Network Based on SDM". Design, Automation & Test in Europe Conference & Exhibition. pp. 566-569.
40. R.W.I. Cheung, P.C.K. Liu & M.S. Demokan. 1993. "The Advantages of Packet Switching Communication Network in Power Supply Industry". IEEE 2<sup>nd</sup> International Conference on Advances in Power System Control, Operations and Management. Vol. 1. pp. 257-261.
41. Martin Gilham. September 2001. "Handbook For The Dial Up Strategic Control Facility". Issue 1.
42. William Stallings. 2007. 8<sup>th</sup> Edition. "Data and Computer Communications". Pearson Prentice Hall. USA.
43. Teach-ict. "What is Packet Switching?" Available at: [http://www.teach-ict.com/technology\\_explained/packet\\_switching/packet\\_switching.html](http://www.teach-ict.com/technology_explained/packet_switching/packet_switching.html)
44. Robert H. Miller & James H. Malinowski. 1994. 3<sup>rd</sup> Edition. "Power System Operation". Mcgraw-Hill. USA.
45. Shakeel Durrani, Imran Jattala, Junaid Farooqi, Naila Shakeel & Mohsin Murad. 2013. "Design and Development of Wireless RTU and Cybersecurity Framework for SCADA System". IEEE 5<sup>th</sup> International Conference on Information & Communication Technologies. pp. 1-6.

46. Elimir Babovic & Jasmin Velagic. 2009. "Lowering SCADA development and implementation costs using PtP concept". XXII International Symposium on Information, Communication and Automation Technologies. pp. 1-7.
47. Wuhong Wang & Geert Wets. 2013. "Computational Intelligence for Traffic and Mobility". Atlantis Press. France.
48. Dan Middleton, Hassa Charara & Ryan Longmire. 2009. "Alternative Vehicle Detection Technologies for Traffic Signal Systems": Technical Report. Texas Transportation Institute.
49. Jan Coetzee, Willem Low & Peter Bullock. "Solar powered Traffic Signals: Myth or Marvel?". Proceedings of 27th Southern African Transport Conference. June 2008. pp. 629 – 644.
50. Stefano Ermon, Yexiang Xue, Carla Gomes & Bart Selman. "Learning Policies For Battery Usage Optimization in Electric Vehicles". Proceedings of European Conference on Machine Learning and Principles and Practice of knowledge Discovery in Databases. September 2012. pp. 1-16.
51. Phoenix Contact. "What you don't know about industrial GSM/GPRS modem communication". A White Paper. [Online]. Available at: [http://web.arrow.com/sites/default/files/pdfs/What\\_you\\_dont\\_know\\_about\\_industrial\\_GSMGPRS\\_modem\\_communications.pdf](http://web.arrow.com/sites/default/files/pdfs/What_you_dont_know_about_industrial_GSMGPRS_modem_communications.pdf)
52. Countrymile Wi-Fi. "How to Setup a long distance Wi-Fi bridge". [Online]. Available at: [http://www.countrymilewifi.com/Images/bridge\\_wifi.jpg](http://www.countrymilewifi.com/Images/bridge_wifi.jpg)
53. Ashley Russell Kotwal, Soon Jae Lee & Yoo Jae Kim. 2013. Traffic Signal Systems: "A Review of Current Technology in the United States". Science and Technology 2013, 3(1). [Online]. pp. 33-41. Available at: <http://article.sapub.org/10.5923.j.scit.20130301.04.html>
54. P. Makhwathana & S. Du. "Analysis on Faults and Maintenance Uncertainties at Traffic Signal Junctions in the City of Johannesburg". 4th International Conference on Traffic

and Transportation Engineering (ICTTE 2015). Madrid, Spain. Journal for Traffic and Logistics Engineering, Vol.3, No. 2, December 2015. pp. 162-167

55. P. Makhwathana & S. Du. "Road ITS Backup Power Source Performance Estimation". 4th International Conference on Traffic and Transportation Engineering (ICTTE 2015). Madrid, Spain. Journal for Traffic and Logistics Engineering, Vol.3, No. 2, December 2015. pp. 143-148

# Appendix A: Wi-Fi scanned frequencies

## A.1: 5455 – 5835 (MHz)

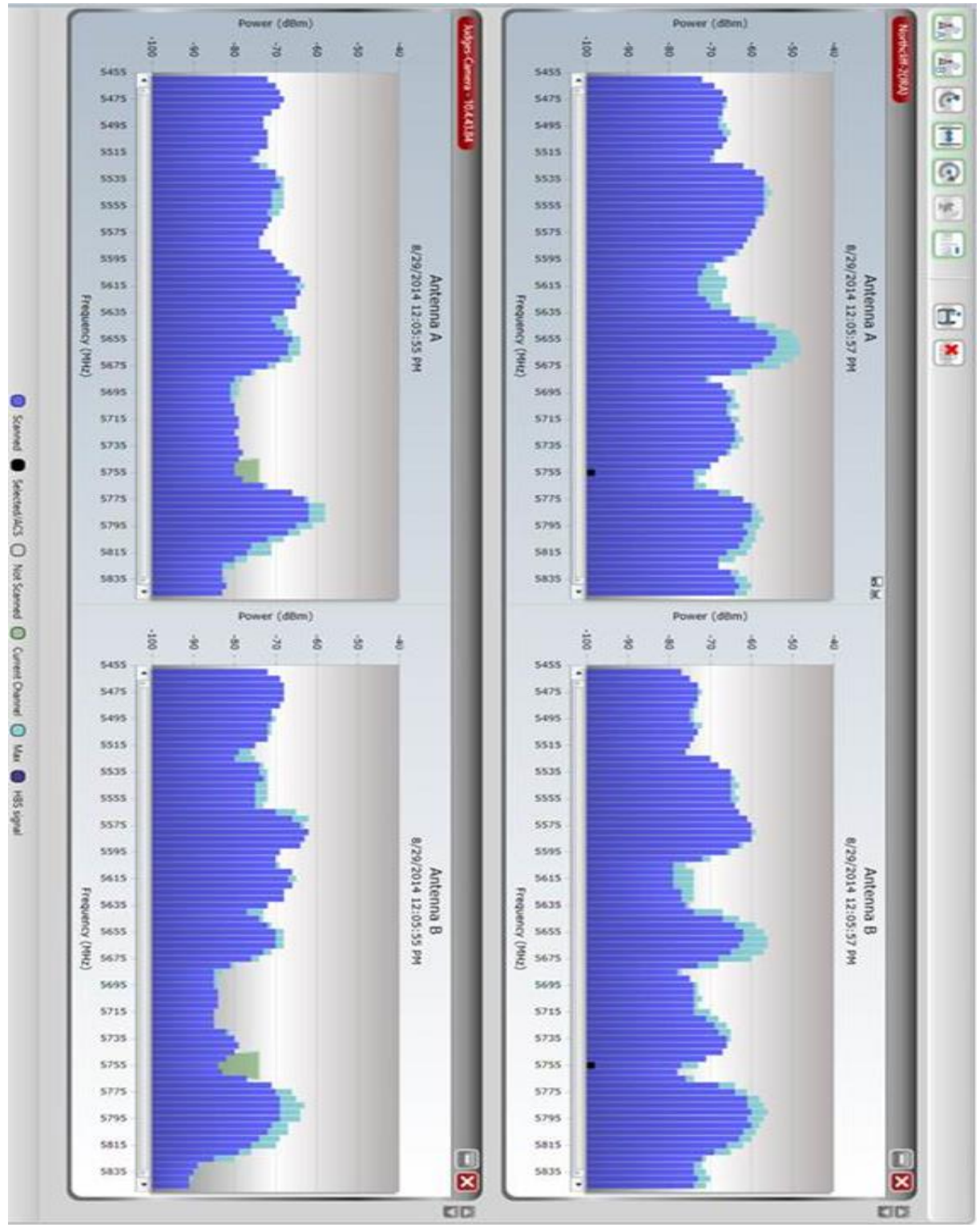



A.2: 5730 – 5845 (MHz)

