

Design of a ferrochrome – slag mechanical separator

Case study

Loice Keresia Gudukeya^{1,a*}, Tawanda Mushiri¹, Charles Mbohwa¹

¹University of Johannesburg, Faculty of Engineering and the Built Environment, Auckland Park 2006, P.O Box 524, Johannesburg, South Africa

Abstract. This research focused on the design of a ferrochrome – slag mechanical separator for a company in Harare, Zimbabwe. The company's current production is 420 tonnes of alloy per month. The aim of project is to raise the production from 420 to 500 tonnes of ferrochrome production per month by introducing a mechanical separator at metal recovery plant that produces 80 tonnes. The difference in specific gravities of ferrochrome and slag is the key principle applied in achieving separation of the two products. The densities of ferrochrome and slag are 6800 kg/ m³ and 2800kg/ m³ respectively hence gravity separation method in water medium can be done.

1 Introduction

The production target of the metal recovery plant at a Harare Company is 500 tonnes per month and the current output is 420 tonnes. The crushing, screening and all material handling processes in the plant are effective because they produces at least 10 tonnes of slag ferrochrome material to go for jigging per day and hence the problem leading to the failure of meeting the target is the final process which is jigging for ferrochrome and Slag separation as it separates 4 tonnes out of 10 tonnes per day. There is a single pneumatic air pulsed jig used for the separation process but it is failing to meet production demands on its own hence it needs the support of another mechanical separator in order to maximise production to the required target. Slag is discarded in large quantities as waste during the process of ferrochrome production. Reclaiming ferrochromium metal entrapped in slag seems to be economic. In order to recover metal, slag has been crushed and subjected to wet magnetic and gravimetric methods [1].

2 Literature Review

2.1 Ferrochrome and Slag Production

Ferrochrome production is done by a direct carbothermic reduction of chromite on three phase submerged arc furnaces. Ferrochrome and slag are the main two products tapped off at regular intervals from tap holes at the bottom of the furnace. Cascade tapping is used to tap slag and metal through the same tap hole into the same metal vessel. Slag will float on the top due to its low density and eventually overflow via a secondary vessel through the ladle spout to the slag pot. Ferrochrome is sent to casting of specific products [3]. The ferrochrome slag products are granulated slag as well as classified slag products made by crushing and screening. The main part of slag is granulated. The crushed and screened slag products are produced from air cooled lumpy slag which is collected from various process phases, e.g. from ladles and launders. The slag is directly granulated during tapping where ferrochrome is tapped into ladles. The overflow from the ladles flows along the slag launder to the granulation pond, where high-pressure water breaks slag into small fractions and efficiently it cools down. The ferrochrome separation

from the lumpy slag happens in a special process, which is based on a gravity and magnetic separation [4].

2.2 Methods of Separation

2.2.1 Gravity Separation.

The gravity separation is a method of separating two materials of different specific gravity that is carried out by their relative motion in response to the combination of force due to gravity and one or more other forces. The other factors besides specific gravity which are shape, size, and weight of the particles affect the relative motion and hence the separation. The ease or difficult of separation is determined by the differences in these factors. The separation effectiveness can be measured by concentration criteria (cc)

$$CC = \frac{d_h - d_f}{d_l - d_f}$$

d_h = Specific gravity of heavy material

d_f = Specific gravity of the fluid

d_l = Specific gravity of lighter material

For relatively ease separation CC should be greater than 2.5 (whether positive or negative) and it becomes difficulty as CC decreases and when $CC < 1.25$ the gravity concentration is not feasible. Besides specific gravity, particle motion is also affected by particle size. The gravity concentration efficiency increases with increase in particle size. For the small particle the motion is mostly affected by friction and has poor response to high capacity gravity separators. The types of gravity separations are spirals, floater density separator, shaking tables; water only cyclone, rotating cones and jigs [2].

2.2.2 Jigging Separation Process.

The jigs follow a 3-stage process to separate the particles of different densities from each other. The processes are differential acceleration of particles, consolidating trickling and hindered settling. Water is used as the separating medium and this allows efficient and continuous recovery of ferroalloy from slag in a particle bed. Types of jigs include: Harz Jig, Denver Jig, Inline pressure Jig.

3 Generation of Possible Solutions

In the study carried out the jigging machines pulsation mechanism can be pneumatic air pulsed mechanism, high

^a Corresponding author: loicekmg@gmail.com

pressure water valve controlled pulsating mechanism but this research objective is to design a mechanical separator with a pulsating mechanism which can apply the use of a diaphragm, plunger or piston driven by an electric motor and a cam and follower actuating mechanism.

3.1 Possible Concept 1: Diaphragm Pulsed Separator

System parts and functions , shown in Fig 1:

- Hutch separating vessel – that’s where water pulsates and stratification occurs
- Screen- the screen is there to maintain the required feed size
- Cam – the cam is driven by a motor shaft through belt drives changing the rotation motion to the linear motion for the follower arm linked to the diaphragm
- Diaphragm- it is moved up and down giving pressure to the water thus producing pulsating currents

Advantages

- Cheap diaphragm material
- Reduced vibrations problems
- Low maintenance costs
- Efficiency jigging
- They are no water leakages
- Easy recovery of coarse material hence less requirements of much grinding process
- Open visual and physical inspection possible with many adjustments

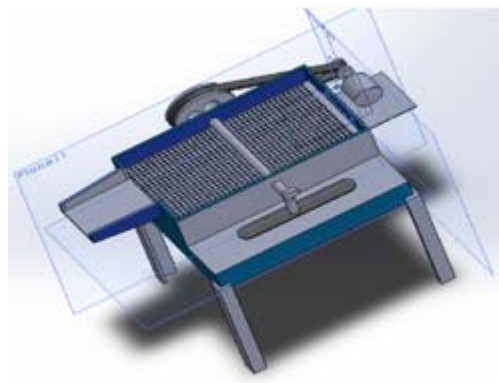

Figure 1: Concept 1 Diaphragm pulsed separation

Disadvantages

- Slow stratification
- Not suitable for recovery of fines

3.2 Possible Concept 2: Plunger pulsed separator

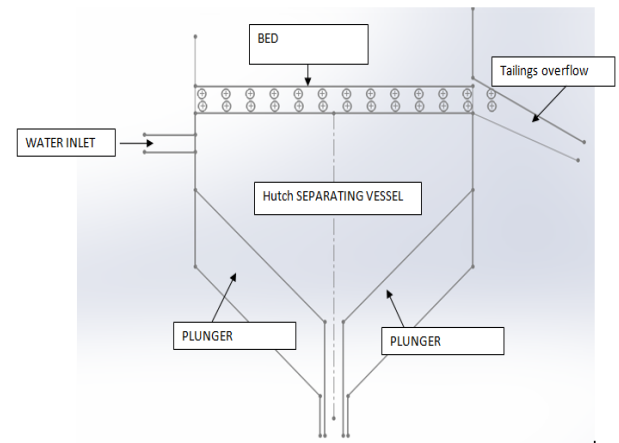

Figure 2: Plunger pulsed separator

System parts and functions

Some of the parts in concept 2 are the same as the parts in concept 1 such as hutch, and screen but concept 2 differs from 1 as it contains plungers instead of a diaphragm and the plungers are placed at the bottom of the separating vessel. Plungers are used to provide change in pressure to water in the hutch so that it pulsates to cause stratification.

Advantages

- High pressure hence high pulsation rate
- Quick stratification

Disadvantages

- There is problems of water leakages therefore requires proper sealing system.
- They are risks of vibrations
- Not suitable for recovery of fines

3.3 Possible Concept 3: Diaphragm pulsed hutch rotated separator

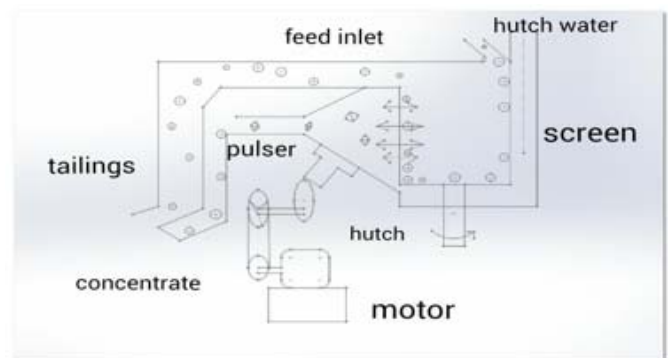

Figure 3: diaphragm pulsed with centrifugal effect separator

System parts and functions

- Hutch -As in previous concepts, in the hutch that’s where pulsation, dilation of the bed and stratification occurs but in this case the hutch is also rotated about a central fed pipe in a spinning bowl so that there will be centrifugal action of the bowl rotation causes feed to distribute on the ragging.

- Screen – used to maintain required feed size and in this concept the screen and the ragging are vertical
- Spinning bowl- Contains the hutch and the screen; it is driven by a motor and makes the hutch to rotate about a central feed pipe.
- Diaphragm- it is connected to the arm linked to the cam driven by the motor so that it induces pulses to the water in the hutch.

Advantages

- Efficiency jiggling
- Can easily separate fine particles

Disadvantages

- The rotor may become unbalanced and cause severe vibrations that may damage the equipment
- It is very expensive high capital and operating costs
- High maintenance costs
- Requires more amount of water to be used

4 Concept selection

The following criteria will be used for comparisons in determining the best solution

A- Function, B- Reliability, C- Ease of maintenance, D- Easy of manufacture, E- Simplicity of layout, F- Efficiency, G- Ergonomics, H- Weight, I- Lifespan, J- Quality, K- Cost

In order to determine the best solution the different concepts was compared according to how much they meet the above criteria. The design criteria was ranked in order of their relative significance using the Binary Dominance Matrix method (BDM). Concept 1 of **diaphragm pulsed jig** was found to be the best solution.

5 Development of Chosen Solution

The design of diaphragm pulsed mechanical separator for ferrochrome and slag consists of sizing of the jug hutch compartment volume, stress analysis for hutch material, particle dynamics calculations, sizing of electric motor, design of power transmission systems (belt drives and pulleys), design of cam shaft and follower links, bearings, screen and diaphragm membrane pulsar.

5.1 Calculating vessel volume and dimensions

Hutch volume = volume of water required + volume of feed material +volume for air space

Calculating volume of the feed:

Feed amount per hour = 112 kg/ hr.

Densities in the feed are 2800 for slag and 6800 for ferrochrome

Maximum vessel volume is obtained by considering slag density = $\frac{112000}{2.8} = 16339.8693 \text{ cm}^3$

Volume of feed = 16339869.3 mm^3

For good concentration the feed amount should be take a range from 7-10% with water amount of 80 -90% of the jig volume

Taking the feed amount to be 7%

Total jig volume by proportion = $\frac{100}{7} \times 16339869.3 = 243000000 \text{ mm}^3$

The hutch is square pyramidal in shape hence volume = $\frac{1}{3} \times b^2 \times h$

Taking $b = h$

$\frac{1}{3} b^3 = 243000000$

$b = 882 \text{ mm}$ take design value 900 mm

Volume of water 90% of jig volume and the other 3% will be for water displacement allowance.

5.2 Calculating vessel pressure and fluidising velocity

Pressure drop due to layout weight of particles $\Delta P = (1-e) \times (\rho_s - \rho) l g$ (culson 2002) where:

- e is bed voidance or porosity
- l is depth , g is acceleration due to gravity
- ρ_s and ρ are densities of solids and liquid respectively

Assuming $l =$ separating height vessel

According to (culson 2002) bed voidance for particles between 75µm to 20mm = 0.41

ΔP due to ferrochrome = $(1-0.416) \times (6800-1000) \times 900 \times 9.81 = 29906 \text{ KN/m}^2$

ΔP due to slag = $(1-0.416) \times (2800-1000) \times 900 \times 9.81 = 9281 \text{ KN/m}^2$

Therefore pressure drop ranges from **9281 to 29906 KN/m²**

$\Delta P = 29906 \text{ KN/m}^2$ is the maximum vessel pressure

The minimum fluidising velocity $U_{mf} = 0.005 \left(\frac{emf^3}{1-emf} \right)$

$\frac{d^2(\rho_s - \rho)g}{\mu}$ (Carman-Kozeny equation) where:

- e_{mf} is the voidance of fluidised bed takes 0.4 according to (C. a. Richardson, Particle technology and separation processes 2002)
- μ is drag coefficient= 0.44 for water

$$U_{mf} = 0.0055 \left(\frac{0.4^3}{1-0.4} \right) \frac{0.02^2(6800-1000) \times 9.81}{0.44} = 0.03 \text{ m/s}$$

After this the following were also designed: Power calculations and Electric motor sizing, Power Transmission V Belts, Cam Shaft, Cam Profile, Follower Push Rod, Follower Helical Spring, Selection of Bearings and The Jig Hutch. Assembly and Working drawings were done.

6 Recommendations and Conclusion

6.1 Recommendations

After assessing the setup of the plant and its current operating condition the following recommendations were deduced:

Safety

- The operators should not overload the machine by putting a feed beyond its capacity
- There should be a good drainage system so that the working environment will not be muddy
- The operators should wear safety clothes at working environment

Quality control

- The operators should properly monitor the water levels for efficient separation
- Correct feed rate should be done
- The operators should monitor the tailings overflow and remove the tailings manually when necessary

6.2 Conclusion

The need for sustainable metal recovery from slag has been the drive to this project and I have appreciated and

grasped a number of concepts in this field. A jigging machine or mechanical separator might be the foundation for recovery of valuable metals or mineral processing thereby reducing environmental impacts and ensuring good waste management of the company.

REFERENCES

[1] M Erdem. Journal of hazardous materials 126, 2005: 176-182.

[2] C. J. Evans, and E. J. Mitchell. A review of mineral size and recovery methods. 1997.

[3] P. Niemela, Helge and Pavi. NFM Brief Revised. 2014.

[4] P. Niemelä and M. Kauppi. Production, Characteristics and Use of Ferrochromium Slags. INFACON XI 2007

Authors' background

Your Name	Title*	Research Field	Personal website
Loice K Gudukeya	PhD Candidate	Sustainability	
Tawanda Mushiri	PhD Candidate	Automation	
Charles Mbohwa	Full Professor	Sustainability	