

Effect of punch stroke on deformation during sheet forming through finite element

Stephen Akinlabi^{1*}, Esther Akinlabi²

¹Department of Mechanical and Industrial Engineering Technology, University of Johannesburg, Doornfontein Campus, Johannesburg, South Africa, 2028.

²Department of Mechanical Engineering Science, University of Johannesburg, Auckland Park Kingsway Campus, Johannesburg, South Africa, 2006.

E-mail: ¹ stephenakinlabi@gmail.com

Abstract. Forming is one of the traditional methods of making shapes, bends and curvature in metallic components during a fabrication process. Mechanical forming, in particular, employs the use of a punch, which is pressed against the sheet material to be deformed into a die by the application of an external force. This study reports on the finite element analysis of the effects of punch stroke on the resulting sheet deformation, which is directly a function of the structural integrity of the formed components for possible application in the automotive industry. The results show that punch stroke is directly proportional to the resulting bend angle of the formed components. It was further revealed that the developed plastic strain increases as the punch stroke increases.

1. Introduction

Sheet forming though conventional is one of the processes of forming technologies that has been widely employed in almost all manufacturing sector [1]-[2]. This may be attributed to the fact that the process can be simple and the fabricated component can be quickly and easily produced with relatively simple tools. Also, mechanical forming under the mechanical working process may include forging, extrusion, rolling, casting, drawing and sheet forming processes. The desired bend shape is achieved by plastically deforming the sheet through the punch impressed on the sheet.

Deformation in most metallic components is actualized conventionally through the application of external loads to the workpiece. The application of the load consequently generates internal stresses and displacement in the material thereby causing distortion within the structure of the material subjected to the load. This, therefore, leads to the deformation of the material geometrically and structurally, however, depending on the magnitude of the applied load, the loaded material may exhibit different characteristics under loading condition such as either an elastic behaviour or a plastic behaviour. When the load is significant the changes in the geometry of the material will not be restored even when the load is released. This process is at the point of permanent change referred to as plastic deformation, a point at which the applied load exceeded the elastic limit and at the yielding phase [3]-[5]. Hence, the structural integrity of the material will be in question if the property of the material is highly altered.

2. Theory of mechanical forming process

The process of bending results in both tension and compression in the sheet metal, with the outer surface of the sheet, undergo tension and stretches while the inner part undergoes compression and contracts, the schematic is shown in Figure 1.

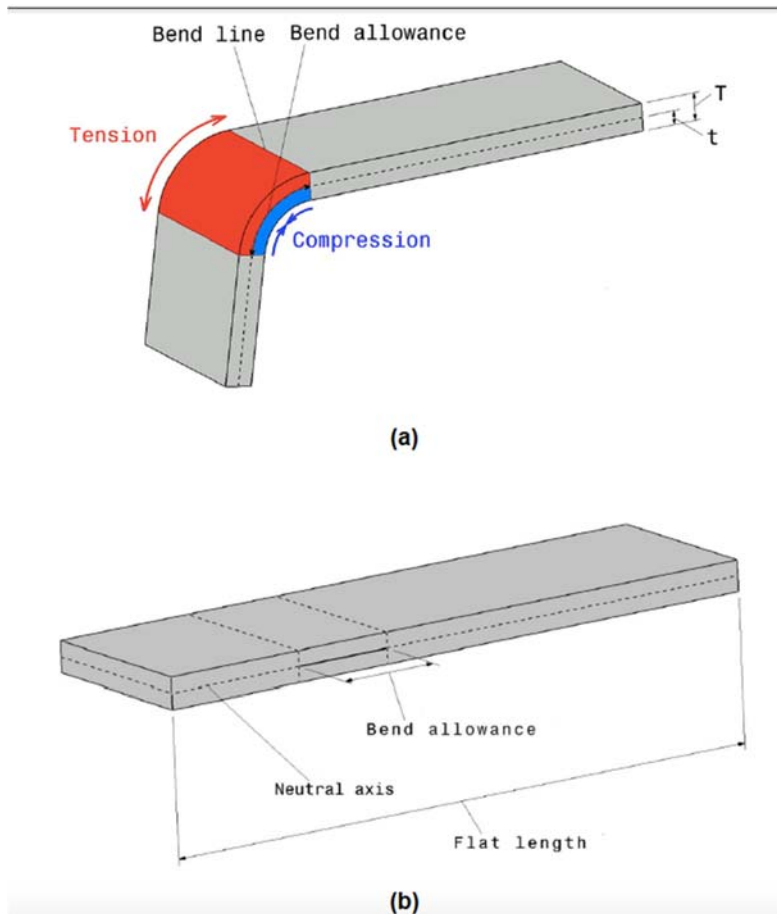

Figure 1. Schematic of the tension and compression during bending of the sheet [6]

This phenomenon may be related to the bend allowance and bend deduction. It is important to state that due to the plastic deformation, there is residual stresses and strains after the forming process. This residual stresses consequently brings about elastic recovery in the material often called spring back which causes shape error in the final fabricated part. The schematic of a mechanical U – bending process is shown in Figure 2 with the punch, sheet, sheet holder and die

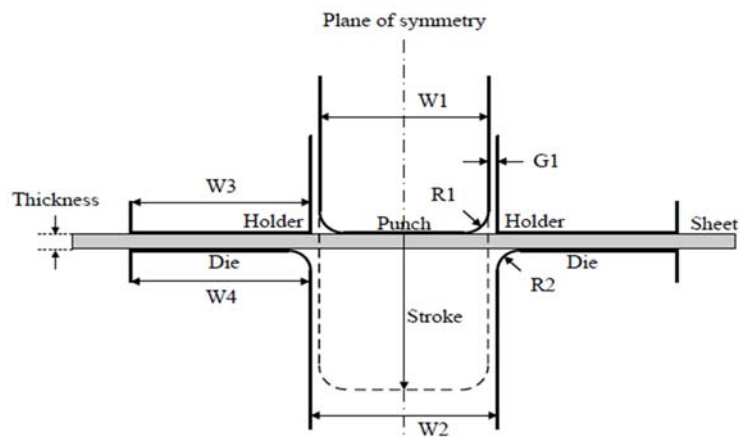

Figure 2. Schematic of a mechanical U – bending setup showing the punch, sheet and the die [1]

Sheet metal during forming is subjected to significant strain rates because the punch impacts the sheet on the die at a given stroke to make the desired shape thereby inducing the stresses. Conversely, strain rate being the change in the deformation of the material is a property that greatly influences the hardening behaviour of sheet materials.

Hence, it becomes necessary to know the effect of the punch stroke on the deformation [1]. One of the earlier studies into the effect of strain rate on the tension-compression behaviour was conducted by Bae and Huh [7]. Finite element analysis of sheet metal forming was carried out by various researchers addressing a different area of study. Choudhry and Lee through finite element analysis of sheet accounted for the effect of inertia [8]. Cho et al. investigated the spring back characteristics in plain strain U bending process through thermo-elastoplastic finite element analysis [2]. Through finite element analysis, the stress distribution is identified, and spring back is predicted, and the compared experimental results are in good agreement [9].

The study of material as isotropic using finite difference method was conducted by Woo [7-8] to solve axisymmetric punch stretching and drawing. The result was in good agreement with the experiment. However, a significant discrepancy was observed in the thickness strain distribution in the tooling and workpiece contact. This phenomenon was attributed to the varying frictional conditions. Wang and Budiansky [9] investigated and introduced elastic-plastic finite element method formulation of stretch forming for a punch and a die of arbitrary shape. The material was observed to the Ramberg-Osgood equation..

3. Finite element analysis

Finite element analysis remains a tool that would continue to be relevant in all spheres of endeavour. This was applied to sheet forming process to evaluate the response and the mechanical properties of the material under loading. Marc software, 2015 version was employed for the analysis. The analysis is static but with elastic plastic material characteristics. The geometry of the steel was defined in Mentate Marc, a plain strain element was used, and the material properties and boundary conditions were setup. The schematic diagram of the mechanical forming process is shown in Figure 3.

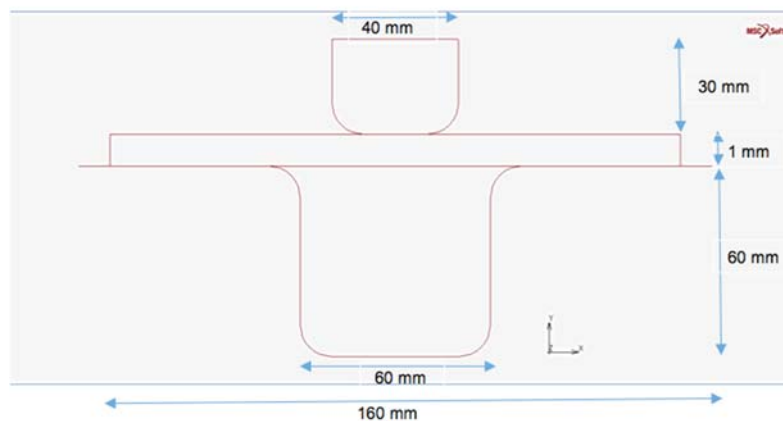

Figure 3. Schematic of Mechanical Forming Process

The finite element setup of the deformable and rigid bodies is shown in Figure 4 as defined in Marc MSC environment.

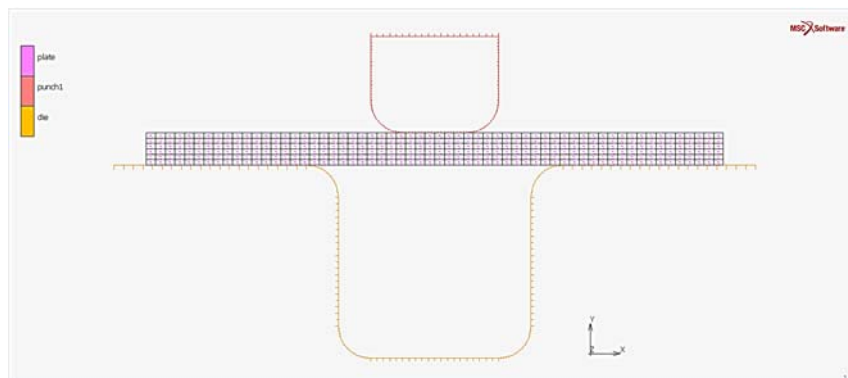

Figure 4. Finite Element setup of the deformable and the rigid bodies

The boundary condition was set by constraining displacement at X direction at the contact between the punch and the plate; this is shown in Figure 5.

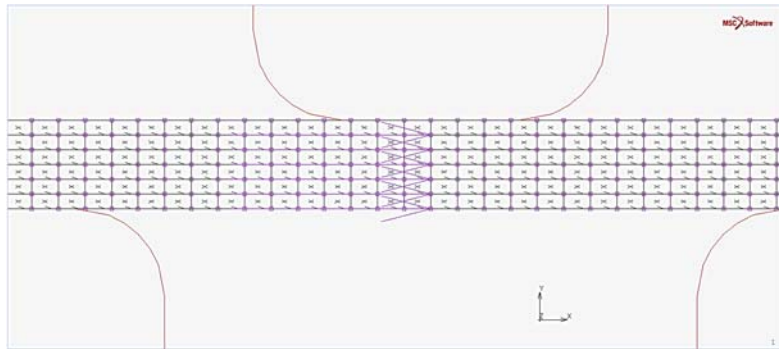

Figure 5. Boundary Condition setup for analysis

4. Result and discussion

The static analysis was conducted and completed with 360 plain strain elements in constant time stepping over fifty steps. The punch total stroke length of 70 mm was defined within which the test measurement was conducted. The resulting deformation described by the bend angles as the punch impressed the sheet were measured, and a bend angle at a stroke of 20 is shown in Figure 6. It was observed that in all the test cases considered, and the bend angle increased with the number of strokes as anticipated due to the force applied.

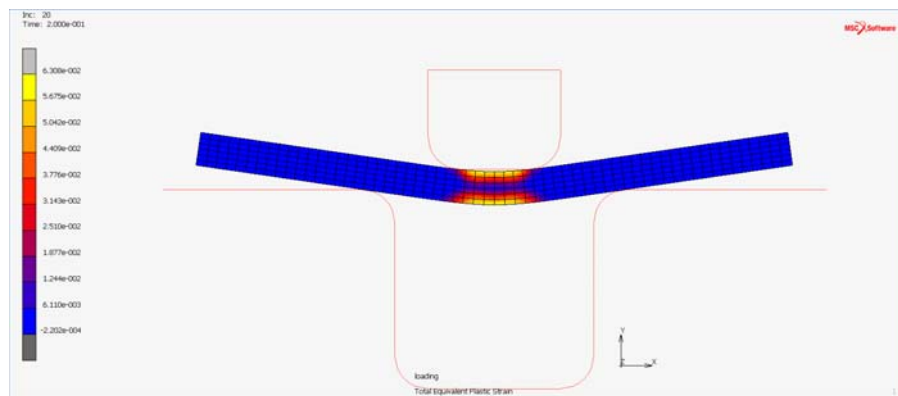

Figure 6. Measured bend angle at a stroke of 20

It is expected in a bending operation that both tensile stresses and compressive stresses are overcome for the desired shape to be achieved. When the bending is eventually achieved, the locked-in stresses cause the material to spring back towards its original position. A Springback phenomenon is seriously dependent on the material and the type of bending process employed, but the good story is that spring back can always be compensated for in any bending operation.

Furthermore, It is important to highlight the significant role of the punch in a bending operation because the bend radius depends on the punch, material properties and the thickness of the material. When a sheet material is bent, the sheet stretches in length over the outside edges of the bend in tension and inner bend radius in compression. This consequently, induces stresses and strains into the sheet metal as the punch presses, causing a permanent deformation of the material. A typical measured Total Equivalent Plastic Strain is shown in Figure 7 and Figure 8. The summary measurements of the Total Equivalent Plastic Strains are presented in Table 1.

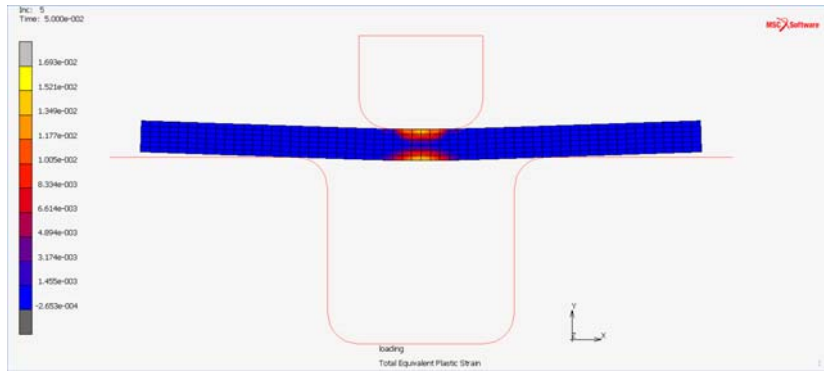

Figure 7. Total Equivalent Plastic Strain measured at a stroke of 5 steps

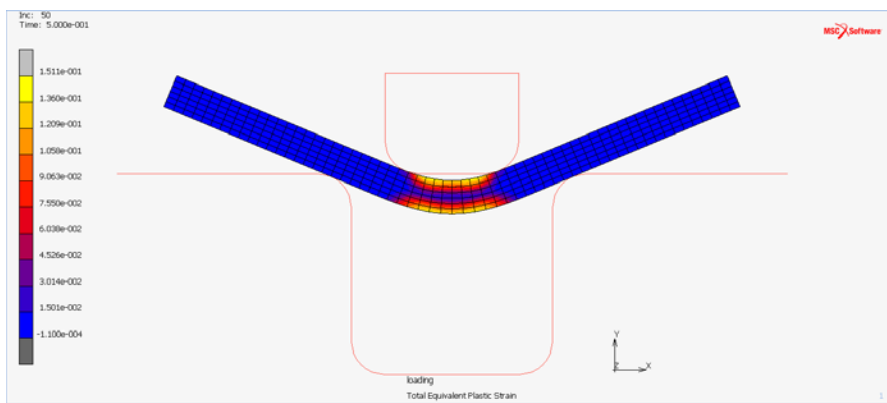

Figure 8. Total Equivalent Plastic Strain

Table 2. Summary of measured Total Equivalent Plastic Strain

Sample number	Incremental steps	Bend angles	Inner bend	Outside bend	Neutral axis
01	5	9.8	1,69E-02	1,52E-02	-2,65E-04
02	10	19.7	3,07E-02	2,30E-02	-1,86E-04
03	15	28.8	3,79E-02	4,27E-02	-1,72E-04
04	20	36.0	5,04E-02	5,68E-02	-2,20E-04
05	25	41.7	5,56E-02	6,35E-02	-2,57E-04
06	30	45.6	7,93E-02	8,92E-02	-2,20E-04
07	35	49.4	9,05E-02	1,02E-01	-2,12E-04
08	40	52.3	1,07E-01	1,19E-01	-1,02E-04
09	45	53.7	1,09E-01	1,23E-01	-1,10E-04
10	50	55.6	9,06E-02	1,06E-01	-1,10E-04

The significant role of the punch in a bending process show that the deformation measured from the bending angle increased through the stroke length. More interestingly are the measured strains (Equivalent Total Plastic Strain) induced into the sheet during the bending. Strain being the response of the material to an applied load, It is therefore important to consider closely three areas – the inner bend radius, outer bend radius, neutral axis- the separating the inner and the outer bend radius. The measured strain at both the inner and outer bend radius was tensile in nature and progressive, but on the other hand, the strain on the neutral axis was compressive.

Also, it was observed that the coverage area of the tensile strain along the inner and the outer bend radius was almost double when compared to the contour plot of the fifth stroke, this further confirmed the significant impact of the punch in a forming operation. What is implied is that further subjecting the piece of material to additional strokes and stages of forming may not be detrimental to the structural integrity of the material. The possible potential solution to manage this development will lie in the choice of the type of material for the punch and the stroke to achieve the desired shape or bend and may be the sequence of the operations required in the bending process.

5. Conclusion

The finite element analysis of the sheet metal forming was conducted and completed using the Marc MSC software version 2015. The study established that the impact of punch stroke on sheet metal can be detrimental through the induced strains and consequent stresses if not monitored and controlled. All the results of the analyses show that all the punch strokes consequently induced an increasing progressive strain. Hence, the induced strains can be attributed to the increasing punch strokes.

Acknowledgements

The authors recognise the financial support of the Division of Internationalization of the University of Johannesburg.

References

- [1] Choi M K and Huh H 2014 Effect of punch speed on amount of springback in U-bending process of auto-body steel sheets. *Procedia Engineering* 81 963-968
- [2] Cho J R, Moon S J, Moon Y H and Kang S S 2003 Finite element investigation on spring-back characteristics in sheet metal U-bending process. *Journal of Materials Processing Technology* 141 109-116.
- [3] Johnson W and Mellor P 1973 *Engineering Plasticity*. Van Nostrand Reinhold Company Ltd., ISBN 0442 30234 7.
- [4] Metal forming Process, 2012, [online]. Available: <http://metalforginginc.com/Publications/Papers/ref133/ref133.htm#> Introduction [Accessed February 2017].
- [5] Prominent Manufacturing Process, 2012, [online]. Available: <http://www.brighthub.com/engineering/mechanical/articles/915.aspx> [Accessed February 2017].
- [6] Bend Works, [online]. Available: <http://www.ciri.org.nz/bendworks/bending.pdf> [Accessed February 2017].
- [7] Bae G H and Huh H 2011 Tension/compression test of auto-body steel sheets with the variation of the pre-strain and the strain rate, In: *Proc. 5th Int. Conf. on Computational Methods and Experiments in Materials Characterisation*, Kos, Greece.
- [8] Choudhry S and Lee J K 1994 Dynamic plane-strain finite element simulation of industrial sheet-metal forming processes. *Int J Mech Sci* 36: 189–207.

- [9] Lei L P, Hwang S M and Kang B S 2001 Finite element analysis and design in stainless steel sheet forming and its experimental comparison. *J Mater Process Technol* 110:70–7.
- [10] Tze-Chi H and Chan-Hung C 1995 A finite element analysis of sheet metal forming processes. *Journal of Materials Processing Technology* 54 70-75
- [11] Woo D M 1995 The stretching forming test. *The Engineer*, 200 876-880
- [12] Wifi A S 1976 An incremental complete solution of the stretch-forming and deep drawing of a circular blank using a hemispherical punch. *Int. J. Mech. Sci.*, 18 23-31
- [13] Wang N M and Budiansky B 1978 Analysis of sheet metal stamping by a finite element method, *ASME J. Appl. Mechs* 100 73-82.