

A novel LabVIEW-based multi-channel non-invasive abdominal maternal-fetal electrocardiogram signal generator

This content has been downloaded from IOPscience. Please scroll down to see the full text.

2016 Physiol. Meas. 37 238

(<http://iopscience.iop.org/0967-3334/37/2/238>)

View [the table of contents for this issue](#), or go to the [journal homepage](#) for more

Download details:

IP Address: 158.196.184.32

This content was downloaded on 29/08/2017 at 12:13

Please note that [terms and conditions apply](#).

You may also be interested in:

[Non-invasive fetal ECG analysis](#)

Gari D Clifford, Ikaro Silva, Joachim Behar et al.

[A practical guide to non-invasive foetal electrocardiogram extraction and analysis](#)

Joachim Behar, Fernando Andreotti, Sebastian Zaunseder et al.

[Fetal QRS detection and heart rate estimation: a wavelet-based approach](#)

Rute Almeida, Hernâni Gonçalves, João Bernardes et al.

[An open-source framework for stress-testing non-invasive foetal ECG extraction algorithms](#)

Fernando Andreotti, Joachim Behar, Sebastian Zaunseder et al.

[Robust fetal ECG extraction and detection from abdominal leads](#)

Fernando Andreotti, Maik Riedl, Tilo Himmelsbach et al.

[Maternal ECG removal in abdominal recordings](#)

R Vullings, C H L Peters, R J Sluijter et al.

[A multi-step method with signal quality assessment and fine-tuning procedure to locate maternal and fetal QRS complexes from abdominal ECG recordings](#)

Chengyu Liu, Peng Li, Costanzo Di Maria et al.

[An efficient unsupervised fetal QRS complex detection from abdominal maternal ECG](#)

M Varanini, G Tartarisco, L Billeci et al.

[A multichannel nonlinear adaptive noise canceller based on generalized FLANN for fetal ECG extraction](#)

Yaping Ma, Yegui Xiao, Guo Wei et al.

A novel LabVIEW-based multi-channel non-invasive abdominal maternal-fetal electrocardiogram signal generator

Radek Martinek¹, Michal Kelnar¹, Petr Koudelka²,
Jan Vanus¹, Petr Bilik¹, Petr Janku³, Homer Nazeran⁴ and
Jan Zidek¹

¹ Department of Cybernetics and Biomedical Engineering, VSB–Technical University of Ostrava, 17. listopadu 15, 708 33 Ostrava, Czech Republic

² Department of Telecommunication, VSB–Technical University of Ostrava, 17. listopadu 15, 708 33 Ostrava, Czech Republic

³ Department of Obstetrics and Gynecology, Masaryk University and University Hospital Brno, Jihlavská 20, 625 00 Brno, Czech Republic

⁴ Department of Electrical and Computer Engineering, University of Texas at El Paso, 500 W University Ave, El Paso, TX 79968, USA

E-mail: radek.martinek@vsb.cz

Received 28 August 2015, revised 13 November 2015

Accepted for publication 4 December 2015

Published 22 January 2016



CrossMark

Abstract

This paper describes the design, construction, and testing of a multi-channel fetal electrocardiogram (fECG) signal generator based on LabVIEW. Special attention is paid to the fetal heart development in relation to the fetus' anatomy, physiology, and pathology. The non-invasive signal generator enables many parameters to be set, including fetal heart rate (FHR), maternal heart rate (MHR), gestational age (GA), fECG interferences (biological and technical artifacts), as well as other fECG signal characteristics. Furthermore, based on the change in the FHR and in the T wave-to-QRS complex ratio (T/QRS), the generator enables manifestations of hypoxic states (hypoxemia, hypoxia, and asphyxia) to be monitored while complying with clinical recommendations for classifications in cardiotocography (CTG) and fECG ST segment analysis (STAN). The generator can also produce synthetic signals with defined properties for 6 input leads (4 abdominal and 2 thoracic). Such signals are well suited to the testing of new and existing methods of fECG processing and are effective in suppressing maternal ECG while



Original content from this work may be used under the terms of the [Creative Commons Attribution 3.0 licence](https://creativecommons.org/licenses/by/3.0/). Any further distribution of this work must maintain attribution to the author(s) and the title of the work, journal citation and DOI.

non-invasively monitoring abdominal fECG. They may also contribute to the development of a new diagnostic method, which may be referred to as non-invasive trans-abdominal CTG + STAN. The functional prototype is based on virtual instrumentation using the LabVIEW developmental environment and its associated data acquisition measurement cards (DAQmx). The generator also makes it possible to create synthetic signals and measure actual fetal and maternal ECGs by means of bioelectrodes.

Keywords: modeling ECGs, fetus' gestational age, hypoxic states, multi-channel abdominal fECG, non-invasive fECG, CTG, STAN

(Some figures may appear in colour only in the online journal)

1. Introduction

The (pre)processing (e.g. filtering, transformation), analysis (e.g. detection and classification of significant points) and medical diagnosis of cardiac pathologies based on ECG signals in adults have reached an advanced level of research and progress. The availability of a number of adult ECG databases, referred to as Common Standards for Quantitative Electrocardiography (CSE) have facilitated these efforts over the years. For details see Fayn *et al* (2007), Gacek and Pedrycz (2012) and Willems *et al* (1990). In comparison, the processing and analysis of fetal ECGs are still in their infancy as compiled and documented in references such as Jagannath and Selvakumar (2014), Hasan *et al* (2009), Sameni and Clifford (2010) and Taralunga *et al* (2014), which summarize the current state of knowledge in these areas.

A variety of unfavorable factors have slowed down the advancement of fetal electrocardiogram (fECG) signal processing. These include:

- (i) Insufficiency of current fECG databases ('Gold Standard Databases'). See Clifford *et al* (2014), Goldberger *et al* (2000), Neilson (2012), and Martinek (2014).
- (ii) The relatively low signal/noise (S/N ratios) in fetal ECG compared to the maternal ECG (mECG). For details see Shuicai *et al* (2013), Morales *et al* (2013), and Khamene and Negahdaripour (2000).
- (iii) Limited clinical insight into the fetal heart and its development.

Given these limitations, our objective here is to attempt to address a number of issues, which pose serious barriers to a wider use of fECG in clinical practice. The area of fetal electrocardiography has increasingly been the focus of attention of both physicians and medical technicians as evidenced by the increase in the number of recent scientific publications devoted to fECG signal processing (Neilson 2012, Behar *et al* 2014a, Clifford *et al* 2014).

Fetal ECGs contain highly relevant information, which could be used to assist physicians in monitoring the health status of fetuses and facilitate the diagnosis of their ailments during pregnancy and delivery. In contrast to the above-mentioned CSE for adult ECGs, no well-established databases for non-invasive abdominal fECG (Chen *et al* 2011) or trans-vaginal fECG (Noventa Medical AB 2012) exist to support the development of new processing/analysis algorithms and inform experimental design. Paper by Vullings *et al* (2013) and Behar *et al* (2013) published the most recent scientific findings in this field, which attest to the current importance of the topic. The results published by Collins *et al* (2013) are of special interest and relevance to the topics discussed in our paper.

Recent advances in the development of computer-based techniques make it possible to apply modern processing and analytical methods, such as soft-computing approaches,

including artificial neural networks, evolutionary computing, neuro-fuzzy systems, and support vector machines, to the area of fetal monitoring (Martinek and Zidek 2012a, Martinek *et al* 2013, Martinek and Zidek 2014, Martinek *et al* 2015a). These in turn open up new opportunities in non-invasive computer-aided medicine. The current trend suggests that the future of fetal monitoring will be associated with sophisticated diagnostic instrumentation integrating two simultaneously applied methods in one instrument: non-invasive trans-abdominal cardiocography (CTG) and ST segment analysis (STAN).

The study by Vullings (2010) suggests that trans-abdominal monitoring can be used for STAN (see Steer and Hvidman (2014)). This is further confirmed by the clinical study by Clifford *et al* (2011).

Our primary objective in this work is to construct and validate a multi-channel non-invasive fECG signal generator for pathological and physiological applications. Experimental results reported in Martinek (2014) show that current fECG modeling as described in many publications is too idealized and matches neither the real environment of the human body nor the real clinical findings. For such modeling to be suitable as a basis for testing modern fECG signal processing methods, it is necessary to take into account the non-linear nature of the human body, which underlies both the pathological and physiological fECG patterns.

Currently, there is only one universal fECG/mECG database, namely the Non-Invasive Electrocardiogram Database (NFD) in Goldberger *et al* (2000), which is usable for experiments in adaptive processing of abdominal fECG (Clifford *et al* 2014). Unfortunately, this database is now rather obsolete and limited as it solely contains physiological records.

The multi-channel fECG signal generator described here takes into account the following factors: gestational age (GA), maternal heart rate (MHR), fetal heart rate (FHR), T wave-to-QRS complex ratio (T/QRS), fECG interferences (biological and technical), and a variety of other parameters. The constructed and validated prototype of the fECG signal generator produced realistic pathological and physiological fECG traces. As part of our work we performed extensive statistical analysis of real abdominal fECG records, acquired in clinical practice. Our system is also well suited to the testing of both new and existing adaptive fECG signal processing methods as well as those used for the detection and classification of significant points in fECGs. Physicians could also use it as a reference tool for evaluating fECG abnormality.

2. Methods

This section is mainly focused on developing a methodology for practical implementation of the fECG signal generator, consisting of three parts: (1) characteristics of real fECG signals (section 2.1), (2) mathematical modeling (section 2.2), and the final design (section 2.3). Table 1 summarizes the relevant results for the statistical processing of the fECG signals. To implement the model, typical fECG settings, which included the durations and voltage ranges of the various fECG parts (waves, segments, and intervals) had to be defined.

2.1. Characteristics of real fECGs

The technology of digital FHR monitoring is well understood. In fact, it is sufficient for detecting the fECG R–R intervals (Freeman *et al* 2012, Hasan *et al* 2009, Lyndon *et al* 2009). Thanks to current advances in fECG signal processing, a detailed fECG analysis could be performed, including the identification of various characteristics of the P and T waves, PQ and QT intervals, and QRS complexes, as demonstrated in a number of studies, for example Chia *et al* (2005), Chia (2006) or Tylor *et al* (2006).

Table 1. Results of statistical processing of the fetal ECG.

	GA (weeks)	NM (–)	AL (ms)	95% CI (ms)	1st MarKel ^a (–)	2nd MarKel ^b (–)
P	20–24	150	41.3	38.6–43.9	0.51	0.059
	25–28	120	45.5	42.9–48.7	0.51	0.068
	29–32	120	48.4	45.5–51.4	0.65	0.077
	33–36	120	53.4	50.2–56.6	0.59	0.084
	≥ 37	150	58.2	54.8–61.5	0.67	0.099
T	20–24	150	118.4	108.7–128.1	0.63	0.091
	25–28	120	133.5	125.7–141.3	0.71	0.112
	29–32	120	140.5	132.7–148.4	0.71	0.125
	33–36	120	149.8	140.7–158.9	0.77	0.143
	≥ 37	150	160.7	152.9–168.5	0.83	0.167
QRS	20–24	150	42.3	38.9–45.7	0.43	0.101
	25–28	120	47.9	43.9–51.8	0.48	0.125
	29–32	120	51.4	47.8–55.5	0.53	0.167
	33–36	120	54.0	50.4–57.7	0.56	0.207
	≥ 37	150	57.8	54.4–61.1	0.59	0.253
PQ	20–24	150	98.7	93.4–103.9	—	—
	25–28	120	104.1	99.6–108.5	—	—
	29–32	120	107.2	102.8–111.7	—	—
	33–36	120	110.8	106.0–115.5	—	—
	≥ 37	150	114.7	110.7–118.8	—	—
QT	20–24	150	220.6	212.7–228.4	—	—
	25–28	120	226.0	218.9–233.0	—	—
	29–32	120	235.5	229.1–241.9	—	—
	33–36	120	242.4	236.1–248.7	—	—
	≥ 37	150	249.4	242.9–255.8	—	—

Meaning: GA—Fetus' GA, NB—Number of Measurements, CI—Confidence Interval, AL—Average Length.

^a 1st MarKel coefficient expresses the fetus-to-adult ratio of the durations of the various ECG segments.

^b 2nd MarKel coefficient expresses the fetus-to-adult ratio of the wave amplitudes of the ECG complexes.

The analysis of abdominal fECG signal characteristics is based on relevant long-term clinical trials:

- Tylor *et al* (2006) mention a study at the Department of Fetal Cardiology, Royal Brompton and Harefield Hospital, London, UK. The trial involved 304 pregnant women in GA Weeks 15–41.
- Chia *et al* (2005) describe a study carried out at the Department of Obstetrics and Gynecology, National University Hospital, Singapore. This involved a sample of 100 healthy fetuses in GA Weeks 18–41.

Our methodology made use of the following studies related to various fECG characteristics by magnetocardiography:

- Kahler in Kahler *et al* (2002) describes real cases of 163 uncomplicated pregnancies in GA Weeks 19–42.

- Stinstra in Stinstra *et al* (2002) describes real cases of 582 uncomplicated pregnancies in GA Weeks 18–41.
- Van Leeuwen in van Leeuwen *et al* (2001) describes real cases of 172 uncomplicated pregnancies in GA Weeks 16–41.

We also include methods used by Martinek in his doctoral thesis, see Martinek (2014), based on selected real abdominal fECGs from clinical practice that were processed by a proposed adaptive system, see Martinek *et al* (2015b), Martinek and Zidek (2012b) and Martinek and Zidek (2012c). Real fECGs at GA Weeks 36–40, run on a STAN S31 instrument that we obtained from its manufacturer (Noventa Medical AB 2012), are also included in this work.

While developing our methodology, we observed that the FHR could be determined as early as the first pregnancy trimester (until GA Week 13), see figure 1. Normal FHR accelerates until the 9th menstrual week. The heart rate in early pregnancy has a characteristic acceleration phase, a peak rate of 175 bpm (± 20) at approximately 9 weeks, followed by a deceleration until approximately 15–17 weeks. After the deceleration phase the heart rate becomes relatively constant after 16 weeks at about 150 bpm (± 25), with a very slight negative slope, until term (Schats *et al* 1990).

However, a detailed analysis of the fECG performed with a view to obtain additional fECG characteristics was not achievable this early as reported by others (Chia *et al* 2005, Chia 2006, Tylor *et al* 2006, Behar *et al* 2013, Collins *et al* 2013, Vullings *et al* 2013). Only some fECG characteristics could be successfully determined in the second pregnancy trimester (GA Weeks 13–27). With this limitation in mind and considering the current state-of-the-art concerning fECG signal processing (Chia *et al* 2005, Chia 2006, Tylor *et al* 2006), the range of GA Weeks 20–42 was determined as optimal for the implementation of our novel multi-channel fECG generator.

The Feature Extractor component of the LabVIEW Biomedical Toolkit (National Instruments 2014) was used to determine the characteristics of the real fECGs. Measurements on analyzed fECG signals were examined and then refined by using the manual review of these fECG records. When using this tool for the first time, we found out that it allowed us to combine automatic and manual detection of fECG signal characteristics in an effective manner. The inaccuracy of automatic detection was minimized by this semi-automatic approach.

Through this manual review, the number of falsely detected and non-detected fECG characteristics was minimized. Three-minute records containing approximately 400 fECGs were analyzed in order to obtain adequate sample number to produce statistically significant results. The three-minute interval was chosen to satisfy the time requirements for the semi-automatic analysis of fECG records. Using this semi-automatic approach, about 30 relevant fECG characteristics of uncomplicated pregnancy were selected for pregnancy week from 20–42 GA interval (i.e. 660 relevant fECG characteristics).

After completion of analysis by the Feature Extractor, the data were statistically processed in MATLAB software environment. The results of this statistical analysis of the real fECG records are point graphs and reference equations shown in figures 2(a)–(f), in which the prediction models (red full lines) and the 95-percent confidence intervals are included.

In performing regression exercise, the interval estimation was defined for the mean value (i.e. $\{\xi(\text{GA})^-, \xi(\text{GA})^+\}$, referred to as the confidence limits) and for the individual observations (i.e. $\{\lambda(\text{GA})^-, \lambda(\text{GA})^+\}$, referred to as the prediction limits).

Statistical analysis results are summarized in table 1. Based on the results, the authors introduced the 1st MarKel and 2nd MarKel correlation coefficients, which represent the similarity between fECG and mECG and were defined for the various fetal GA intervals.

The data indicated that as GA increased, the fetal cardiac time intervals significantly increased.

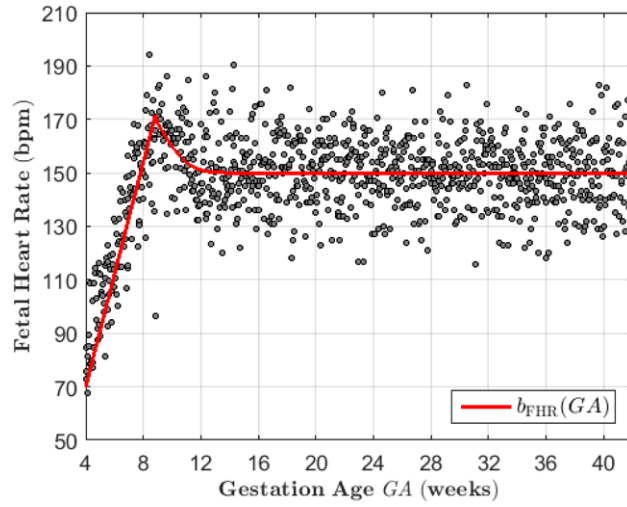

Figure 1. FHR as a function of the fetus' GA ($b_{\text{FHR}}(\text{GA})$ is FHR dependence on the fetus' GA).

The cardiac interval of healthy fetuses may be useful as reference values for the detection of abnormal changes in cardiac electrical conduction (Chia *et al* 2005).

The linear regression equations (1)–(6) given below quantify the relationships between different fECGs signal characteristics and GA.

$$b_{\text{FHR}}(\text{GA}) = -0.065 \cdot \text{GA} + 152.503, R^2 = 0.0016, \quad (1)$$

$$t_{\text{p}}(\text{GA}) = 0.992 \cdot \text{GA} + 18.862, R^2 = 0.3528, \quad (2)$$

$$t_{\text{T}}(\text{GA}) = 2.414 \cdot \text{GA} + 66.032, R^2 = 0.2891, \quad (3)$$

$$t_{\text{QRS}}(\text{GA}) = 0.891 \cdot \text{GA} + 23.137, R^2 = 0.2387, \quad (4)$$

$$t_{\text{pQ}}(\text{GA}) = 0.946 \cdot \text{GA} + 77.885, R^2 = 0.1767, \quad (5)$$

$$t_{\text{QT}}(\text{GA}) = 1.739 \cdot \text{GA} + 181.141, R^2 = 0.2441, \quad (6)$$

for $\text{GA} \in \{x : x \in \mathbb{R}^+, 20 \leq x \leq 42\}$. In other words, equations (1)–(6) form the mathematical model of fetal heart development in terms of fECG characteristics as a function of the GA. The distribution of individual points in figures 2(a)–(f) was used to determine linear regression equations and the coefficient of determination R^2 , which is indicative of the quality of the regression model.

2.2. Fetal cardiac activity modeling

Currently, several ECG mathematical modeling methodologies are available, such as the Fourier series (Halawani and Kari 2014), vector cardiogram (Martinek *et al* 2015c), Hermitian functions (Matonia *et al* 2005), and others.

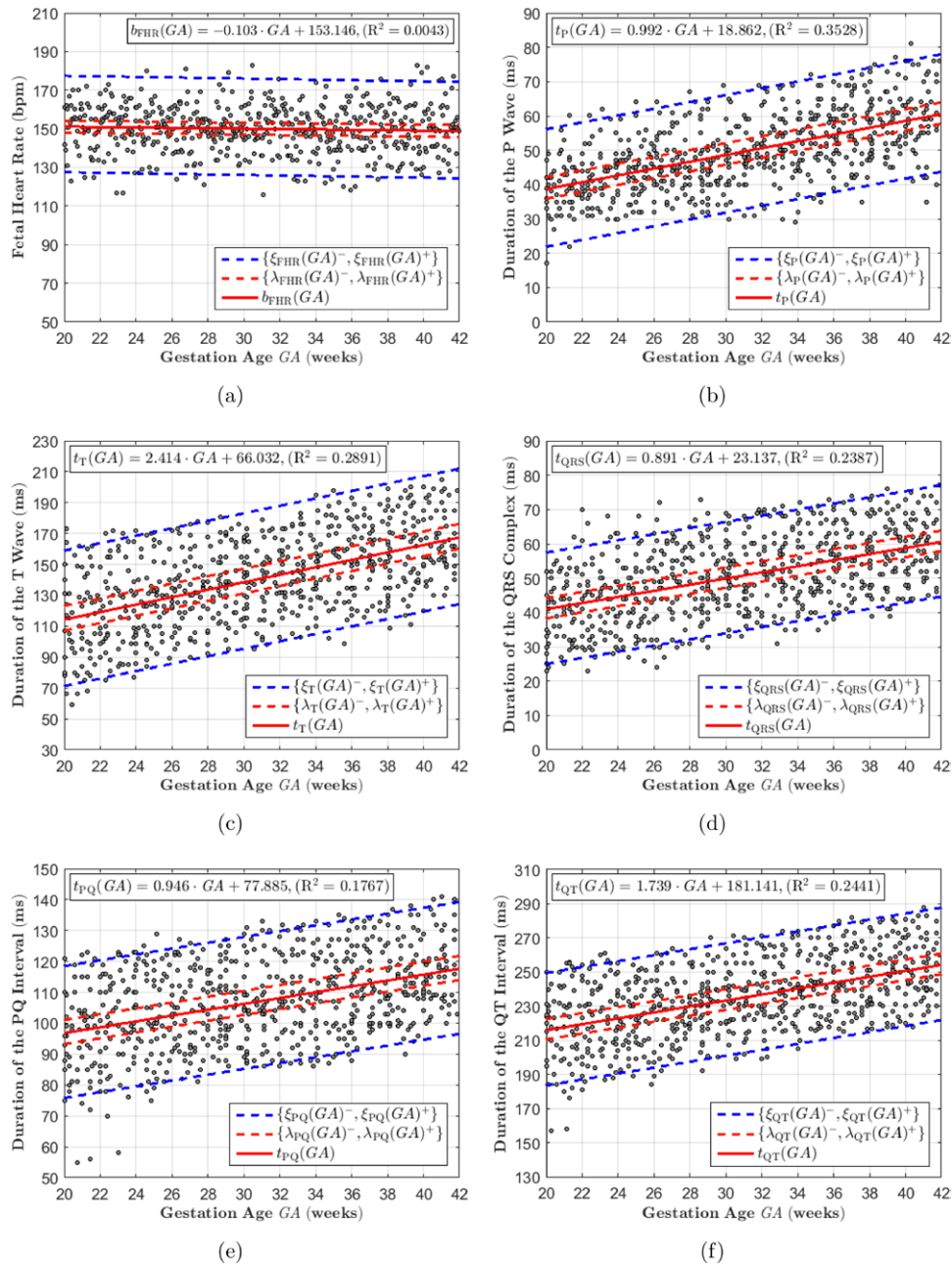

Figure 2. (a) FHR as a function of the fetus' GA; (b) P waveform length as a function of the fetus' GA. (c) T waveform length as a function of the fetus' GA; (d) QRS complex length as a function of the fetus' GA; (e) PQ interval length as a function of the fetus' GA; (f) QT interval length as a function of the fetus' GA.

The mathematical fECG modeling approach (based on the abdominal signal modeling) described by Matonia *et al* (2005) was used in our paper. This method enables the generation of electrocardiographic signals with strictly-defined parameters, and allowed us to control the

type and level of the added noise. Three Hermitian functions, described by equations (8)–(10) were used for the modeling of fetal and maternal electrocardiographic signals. Equation (7) denotes the symbolic expression consisting of a shape coefficient $K(b;t)$ in $s^{-\frac{1}{2}}$ and a simple basis (Gaussian) function $\varrho(t)$.

$$h(t) = K(b;t) \cdot \varrho(t), \tag{7}$$

$$h_0(t) = \frac{1}{\sqrt{b \cdot \sqrt{\pi}}} \cdot \exp\left(-\frac{t^2}{2 \cdot b^2}\right), \tag{8}$$

$$h_1(t) = \sqrt{\frac{2}{b \cdot \sqrt{\pi}}} \cdot \frac{t}{b} \cdot \exp\left(-\frac{t^2}{2 \cdot b^2}\right), \tag{9}$$

$$h_2(t) = \sqrt{\frac{2}{b \cdot \sqrt{\pi}}} \cdot \left(\frac{t^2}{b^2} - \frac{1}{2}\right) \cdot \exp\left(-\frac{t^2}{2 \cdot b^2}\right) \tag{10}$$

where b is the width of the modeled curve (waveform), and t is time (both in s) and $\varrho(t)$ denotes the dimensionless basis function.

Both the fECG and mECG signals can be easily and effectively modeled using the aforementioned Hermitian functions given in equation (11) below to achieve adequate shape variability by means of multiplication and superposition as described in Matonia et al (2005).

$$H_k[n] = \begin{cases} h_0[n] \cdot \frac{10 - k}{10} + h_1[n] \cdot \frac{k}{10}, \\ k \in \{x : x \in \mathbb{R}^+, 1 \leq x \leq 10\}, \\ h_0[n] \equiv h_0(n \cdot T_S), n \in \mathbb{Z}^+ \setminus \{0\}, \\ h_1[n] \equiv h_1(n \cdot T_S), n \in \mathbb{Z}^+ \setminus \{0\}, \\ h_0[n] \cdot \frac{(k - 10)}{10} + h_1[n] \cdot \frac{(20 - k)}{10} + h_2[n] \cdot \frac{(k - 10)}{20}, \\ k \in \{x : x \in \mathbb{R}^+, 11 \leq x \leq 20\}, \\ h_2[n] \equiv h_2(n \cdot T_S), n \in \mathbb{Z}^+ \setminus \{0\}. \end{cases} \tag{11}$$

where k describes the shape of the QRS complex (P-wave or T-wave) and T_S is a sampling period (in s). According to Matonia et al (2005), it is possible to model a single cardiac cycle by using equation (11). Therefore, proper amplitude-time relations between the particular waves must be determined, see table 1.

2.3. Maternal-fetal ECG signal generator description

The block diagram of the fECG signal generator is shown in figure 3, where CRC represents Clinical Recommendations for Classification, NLT—Non-Linear Transformation, PFU—Position of the Fetus in Utero, and CP—Clinical Practice.

In the text below, the names of individual blocks of the diagram as per figure 3 are typed in bold. The block **CRC CTG-STAN** represents clinical recommendations for CTG evaluation according to FIGO (International Federation of Gynecology and Obstetrics (FIGO 2015)) enacted in the Czech Republic in 2011, as well as the ST analysis criteria for termination of pregnancy in intermediary and abnormal CTG according to Noventa Medical AB

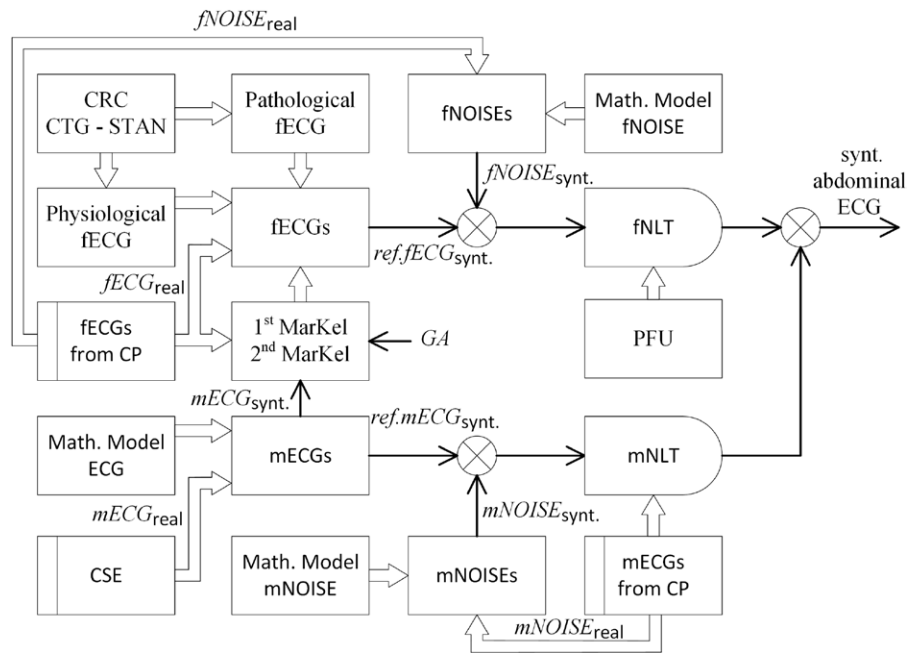

Figure 3. Simplified block diagram of the fECG signal generator.

(2012). Using the thus-defined criteria, the designed generator can be used to generate physiological (normal), suspicious (intermediary), pathological (abnormal) and preterminal CTG. In addition, any denivelation of the ST segment with respect to the basic isoelectric line, an episodic increase in the T/QRS ratio, a stable increase in T/QRS, and biphasic ST (biphasicity levels of the ST segment: BP1, BP2 and BP3) could be produced by the fECG signal generator (Martinek 2014). The **Physiological fECG** and **Pathological fECG** were assembled based on the above-described blocks, which are necessary to synthesize the reference fECG ($ref.fECG_{synt.}$).

The database of raw real abdominal fECG records is represented by the block **fECGs from CP**. The data contained in this database were obtained by the authors from clinical practice. Currently, this subsection of the database contains approximately 150 hours of physiological and pathological records in GA Weeks 36–40. Another major subsection of the database contains fECG records in GA Weeks 20–42, used for clinical studies (see section 2.1).

The 1st and 2nd coefficients were introduced in section 2.1 (table 1). These coefficients are contained in the block **MarKel** which represents an apparatus that models the shape and time characteristics of fECG as a function of the required GA based on the knowledge of maternal $mECG_{synt.}$ and MarKel coefficients.

The reference synthetic signal $ref.fECG_{synt.}$ was generated using the **fECGs** block. This block in turn used the shape and time characteristics of fECG for the given GA, which mutates according to **fECGs from CP** i.e. time characteristics of fECG that depend on FHR. Furthermore, this block modifies fECG morphology depending on the chosen type of physiological or pathological fECG from the **Pathological fECG** and **Physiological fECG** blocks.

The **CSE** block shown in the simplified block diagram in figure 3 represents the database of real adult human ECG records used worldwide. For more details see Fayn et al (2007), Gacek and Pedrycz (2012) and Willems et al (1990).

A general mathematical model of ECG signals created using Hermitian functions was introduced in section 2.2. This model is represented by the **Math. ECG model** block.

The **mECGs** block generates the synthetic signal $mECG_{\text{synt}}$, based on the ECG mathematical model and the pattern of real ECG waveforms created by the **CSE** block. $ref.mECG_{\text{synt}}$ is also an output of this block, while $ref.mECG_{\text{synt}} = mECG_{\text{synt}}$.

Real thoracic mECG records are represented by the **mECGs from CP** block. Approximately 150 hours of real 2-lead records were included. These were obtained by the authors from clinical practice. The 2-lead layout is based on Martinek *et al* (2015a) and Martinek and Zidek (2012b), designed for advanced methods of fECG extraction.

Mathematical models of interference were included in the **Model mNOISE** block. This block represents the basic forms of interference, i.e. isoelectric line variations, the effect of breathing, myopotentials, lead and movement artifacts, etc which are found in real mECG records. For more details about mECG interference modeling, see Sameni *et al* (2007) and Behar *et al* (2014a).

mNOISEs: This block synthesizes $mNOISE_{\text{synt}}$, based on **mECGs from CP** and the mathematical interference model, and it superposes $mNOISE_{\text{synt}}$ with $ref.mECG_{\text{synt}}$.

The **mNLT** and **fNLT** blocks incorporate the nonlinear nature of ECG signal propagation in the body (**mNLT**—from the mother’s heart to the abdominal region; **fNLT**—from the fetus’s heart to the mother’s abdominal surface). Currently, scientific studies mainly use linear models. For example see Singh *et al* (2016), Martinek and Zidek (2012c) and Zeng *et al* (2008). However, these models prove to be insufficient, and research into a nonlinear model of ECG propagation in the human body has only just begun (Martinek and Zidek 2012b, Martinek 2014, Ma *et al* 2014).

The fetal position in the uterus is taken into account in the **PFU** block and has a crucial impact on the shape of the resulting fECG. For more details, see Martinek *et al* (2015c).

Math. Model fNOISE: This block includes mathematical models of interference (isoelectric line variations, lead and movement artifacts, uterine contractions, etc) found in real fECG records. For more information about fECG interference modeling, see Martinek (2014), Rihana *et al* (2009) and Matonia *et al* (2005).

fNOISEs: This block synthesizes $fNOISE_{\text{synt}}$, based on **fECGs from CP** and the mathematical interference model, and it superposes $fNOISE_{\text{synt}}$ with $ref.fECG_{\text{synt}}$. The resulting synthesized abdominal fECG record is given by the sum of the simulated fECG and mECG waveforms.

An ideal synthetic maternal signal, $mECG_{\text{synt}}$, could be generated by making use of the mathematical models described above as well as real records of $mECG_{\text{real}}$ from the CSE.

This diagram shows how one individual abdominal fECG or thoracic mECG lead of our multi-channel generator is modeled and generated by using a proper combination of signal generator parameters.

Pathological waveforms were modeled based on Stancases’ database (Stancases 2015). A limited set of several pathological waveforms from clinical practice was found in this database. The limitation in the number (tens) of available pathological cases in the database was explained by the fact that when any pathology in the FHR signal and in the T/QRS occurred that posed a threat to the vitality of the fetus, surgical termination of pregnancy had to be done and fetal monitoring had to be terminated.

The development of models for pathological waveforms has only begun in very recent years (Sameni and Clifford 2010, Abdulhay *et al* 2014, Martinek 2014, Agostinelli *et al* 2015). In this paper, source data for modeling pathological fECGs were obtained from Stancases using image processing methods as the data were available only as images. These methods were

applied to obtain data that could be used in the fECG generator together with CTG + STAN clinical recommendations for evaluation. See the **Pathological fECG** block.

The $\text{ref.mECG}_{\text{synt}}$ signal disturbance was modeled based on real records from CP ($\text{mNOISE}_{\text{real}}$) and the disturbance mathematical model of mECG (mNOISEs). This topic is described in more detail elsewhere (Wei *et al* 2013, Behar *et al* 2014a). Furthermore, $\text{mNOISE}_{\text{real}}$ was superimposed on $\text{ref.mECG}_{\text{synt}}$.

The $\text{ref.fECG}_{\text{synt}}$ signal disturbance was modeled based on real records from CP ($f\text{NOISE}_{\text{real}}$) and the disturbance mathematical model of fECG (fNOISEs). This topic is described in more detail in Behar *et al* (2014a) and Estes *et al* (2014). Furthermore, $f\text{NOISE}_{\text{real}}$ was superimposed on $\text{ref.fECG}_{\text{synt}}$.

The human body influences (interference, delays, etc) were modeled with the use of non-linear functions **fNLT** (**PFU** or progression of fetus in the uterus) and **mNLT** (mECG propagation in the human body). See Martinek (2014), Niknazar *et al* (2013) and Nasiri and Faez (2012) for more details. The modeling of mECG propagation was based on the analysis of real records from CP. See Willems *et al* (1990) and Okamoto and Ohsawa (1988) for more details.

The outputs of the Multi-Channel Abdominal Fetal Electrocardiogram Signal Generator were primarily synthetic abdominal ECGs that contained a mixture of fECG, mECG, and disturbances. The secondary signals generated were reference fECGs and mECGs.

3. Results

The predicted regression straight lines presented by equations (1)–(6) were integrated into the LabVIEW developmental environment for resolving fECG signal processing problems. The fECG signal generator application software enabled the following quantities to be set by means of its graphical user interface, see figures 4 and 5:

- FHR and MHR—constant values generated at random from a predefined interval.
- GA range from Week 20 to Week 42.
- T/QRS—constant value or value generated at random from a predefined interval, ST elevations/depressions.
- Properties (amplitude and length) of the ECGs.
- Interferences and ECG artifacts.

The generator software offers the option to select either an automatic or manual fECG property setting. Parameters of the generator may be set up manually by an user (based on his experience and knowledge) online, during signal generation. In automatic mode, these parameters may be set up automatically according to selected type of fECG and mECG signals from the database and clinical recommendation. The software also allows the user to select some of the existing predefined traces, based upon information derived from real traces acquired from thoracic (TE1, and TE2) and abdominal (AE1, AE2, AE3, and AE4) bioelectrodes (see figure 5). The prominent properties of the generator include fECG noise-to-signal superposition, which can serve to simulate various narrow-band or broad-band interferences (network interferences, motion artifacts, uterine contractions, zero isoline drift, and others). The system allows both physiological and pathological fECGs to be generated and the fetus' hypoxic effects (mild or severe tachycardia, bradycardia, etc) to be simulated. Furthermore, the changes in the T/QRS occurring during the fetus' hypoxic states can be simulated based on criteria for STAN evaluation.

The unknown environment of the human body was modeled by using non-linear functions previously developed by the author's team (Martinek and Zidek 2012b, 2012c, Martinek

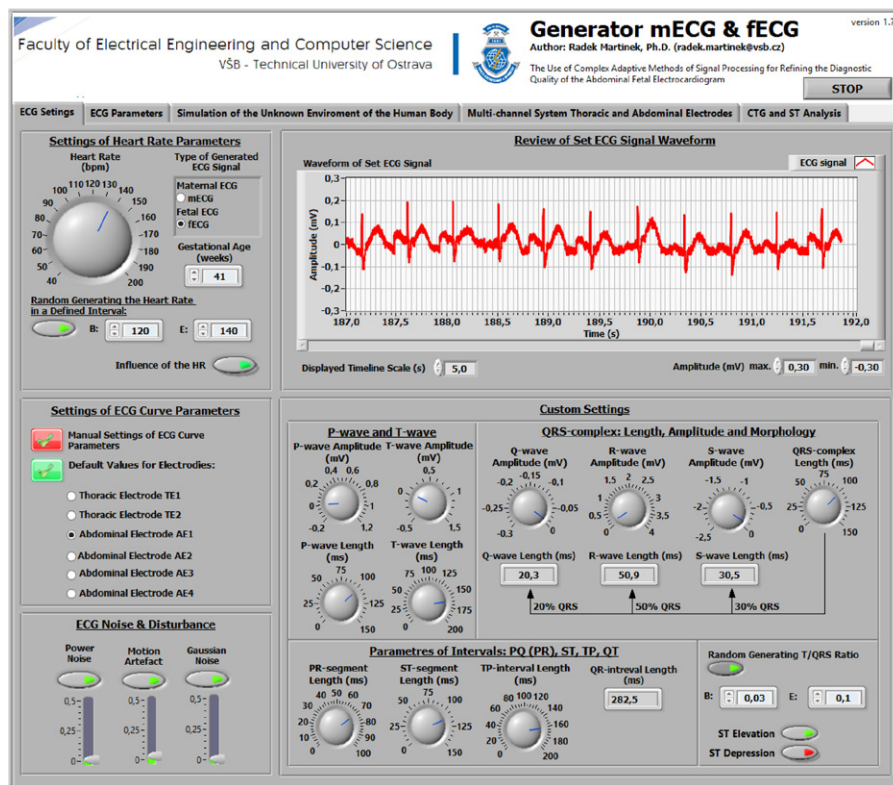

Figure 4. Front panel (GUI)—Multi-channel abdominal fetal electrocardiogram signal generator.

2014). The principle of human body non-linearity modeling used in the multi-channel fECG generator is illustrated in figure 3.

In figure 6, a conception of an experimental workplace is shown. In this figure, SYN block represents the synthesizer (fECG, mECG), PPM block stands for Progressive Parametric Model, ADP block is for Adaptive Data Processing, respectively. DAQ_{OUT} is an output, DAQ_{IN} is an input to the system, DB is a database of real as well as synthetic pathological and physiological records of fECG and mECG signals.

The functional prototype described here was based on virtual instrumentation (VI) making use of the LabVIEW developmental environment and associated data acquisition measurement cards (DAQmx).

Using hardware and software means (National Instruments 2014, 2015), it was possible to generate synthetic fECG and mECG as well as to detect these signals in their real form.

The concept proposed in figure 6 facilitates our understanding of how continuous recording of real fECG and mECG signals from CP and DB could be used in this novel Virtual Instrument (VI). Such a DB is necessary for subsequent updates of PPM of the synthetic fECG and mECG signals, which are adaptively parametrized with use of ADP (Martinek *et al* 2013). Based on the database of fECG and mECG records, this system allows a continuous automatic and adaptive improvement of generator's mathematics models, which are used for a signals synthesis.

Building upon the concept shown in figure 6, it was possible to compare real and synthetic records of fECG and mECG from the DB. This was a basic condition for verification of functionality of the proposed multi-channel abdominal fECG signal generator.

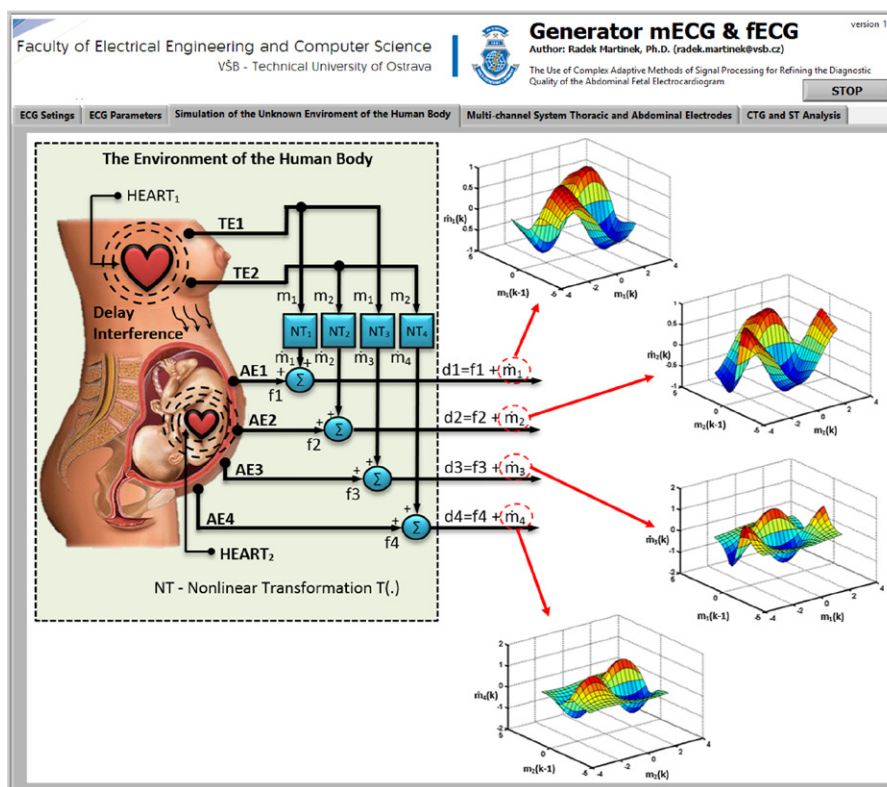

Figure 5. Conceptual diagram of the non-linear model of the human body.

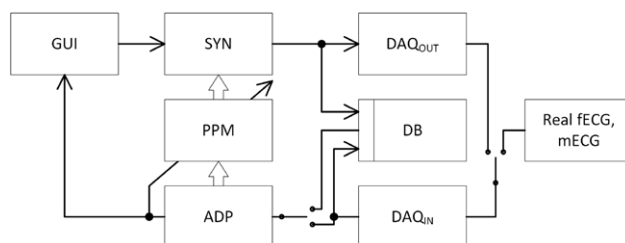

Figure 6. Concept of experimental workplace.

Concept of described fECG generator (see figure 6) allows testing of developed or existing CTG (e.g. Monica AN24) and STAN (e.g. STAN S31) monitoring and automatic diagnostics devices. Unit under test is connected to the generator’s output signals configured by user’s parameters (i.e. a reference signal with known properties, see figure 3). This approach allows testing of conceptual new diagnostic devices without any co-operation between design center and clinical practice (for example testing of progressive methods for automatic detection of hypoxic states is very difficult without known reference signal).

Figures 7(a) and (b) show a comparison of real and synthetic signals fECG in the time and frequency domains. A complex adaptive system has been used to process real fECG signals (Campillo *et al* 2013, Martinek 2014). Synthetic signals were modeled based on the progressive parametric model (see figure 6). Subjective comparison of real and synthetic

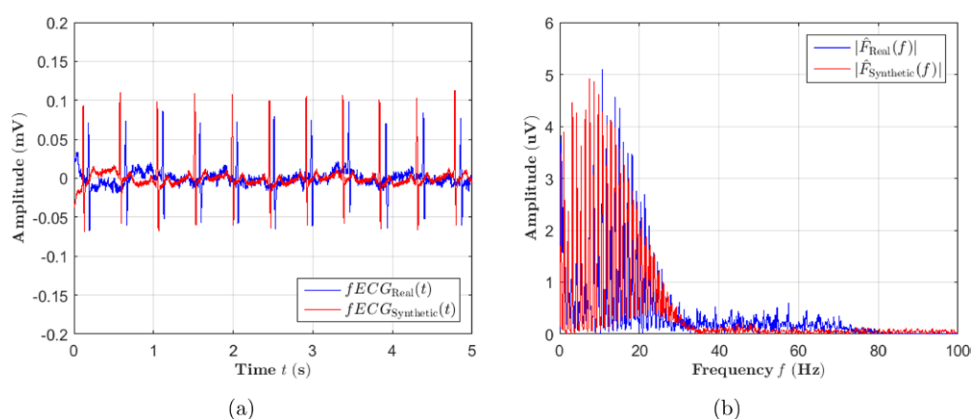

Figure 7. (a) Comparison of real (from CP) and synthetic fECG in time domain (FHR = 131 bpm, T/QRS = 0.1); (b) Comparison of real (from CP) and synthetic fECG in frequency domain (FHR = 131 bpm, T/QRS = 0.1).

signals produced good agreement between these signals. A high correlation rate was observed between these signals.

Figures 8(a)–(d) demonstrate the functionality of the developed fECG signal generator by showing 10 min records of FHR and T/QRS values. Figures 8(a) and (b) show real pathological and physiological recordings while figures 8(c) and (d) show the corresponding simulated waveforms. Based on the real recordings, the authors were able to simulate similar pathological and physiological waveforms.

4. Discussion

The multi-channel fECG generator described above has the potential to contribute to future research in automatic classification of CTG as well as computer-aided analysis of fECG records (STAN, etc). As was mentioned in the introductory section, the lack of a comprehensive database, in which pathological CTG and fECG records constitute a key source in the development of automatic classification systems, has greatly impeded research in this area. It is very difficult or even impossible to acquire such records from clinical practice, especially in situations where the fetus is immediately at risk (e.g. hypoxia or asphyxia), monitoring is discontinued, and pregnancy is surgically terminated. The implementation of the prototype described here has enabled us to build upon the knowledge available in the only resource on the clinical recommendations for CTG and STAN classification (Martinek 2014), where well-known pathological fetus conditions are identified. The generator enables researchers and clinicians to investigate the detailed properties of abdominal fECGs and elucidate the intricacies of trans-abdominal fetal monitoring.

A fECG signal generator, which takes into account the fetus' GA, could be used by physicians as a reference tool when they are assessing abnormalities in the fECG (such as FHR, morphology, and duration of the fECG segments). Based on the fetus' GA, the physician could determine the fECG properties for a normal pregnancy and compare them to the fECG observed. This approach could result in the identification of pathological cases. No well-established and standardized recommendations for CTG and STAN analysis are currently available to aid in the assessment of potentially pathological fECG patterns. Therefore, this system has the potential to open up a large area of research in future clinical investigations.

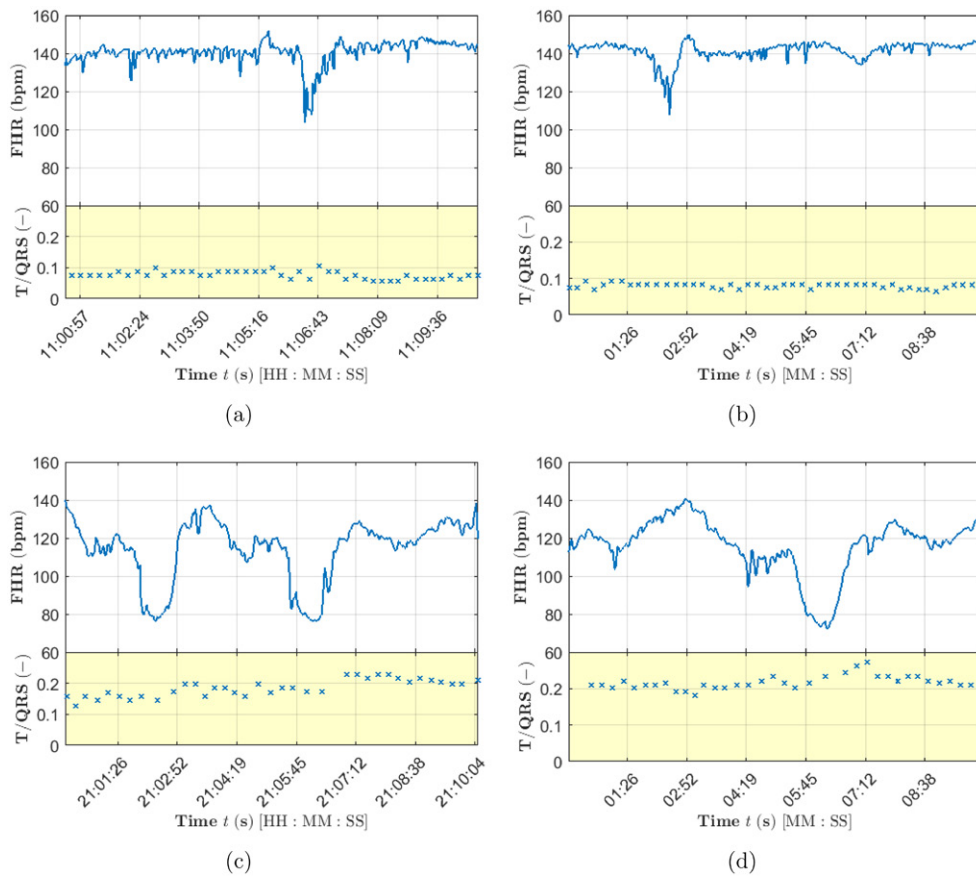

Figure 8. (a) Record of real physiologic course of FHR and the T/QRS ratio from CP (Stancases 2015); (b) Simulated record of real physiologic course of FHR and the T/QRS ratio; (c) Record of real pathologic course of FHR and the T/QRS ratio from CP (Stancases 2015); (d) Simulated record of real pathologic course of FHR and the T/QRS ratio.

In summary, our vision is to create a comprehensive database that seamlessly captures all the realistic attributes of both physiological and pathological fECG records. A well-proven and validated fECG database that could be reliably used by the medical research and clinical community is of paramount interest in fetal electrocardiography.

Verification of the functionality of the implemented fECG generator was also evaluated from the medical specialist’s point of view. A set of sample records was prepared for the purpose of specialist evaluation. This set included both real and simulated CTG and T/QRS records, with information about the source recordings removed. A set of 10 samples recordings with uniform representation was used for this purpose (see figure 9 as one of the test samples). This test set was presented to specialists in the field (in particular to obstetricians). Engaging tens of specialists we carried out this pilot investigation. The pilot data clearly showed that specialists were not able to distinguish between real and simulated signals. For future specialist evaluations of the generated waveforms, we plan to expand the test set by including more samples, engage more specialists and focus on diagnostic accuracy and recognition of both physiological and pathological conditions using the simulated results.

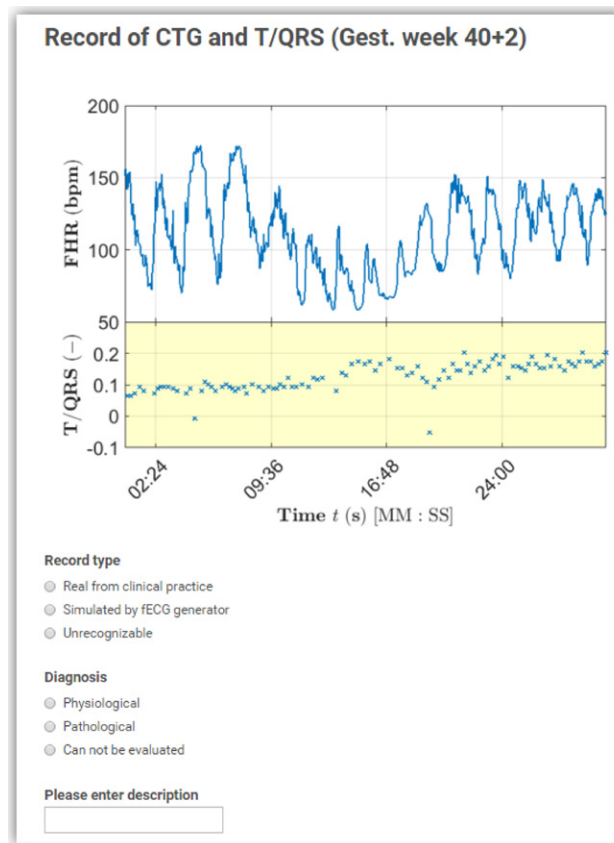

Figure 9. Form for CTG and T/QRS classification.

5. Conclusion

This paper describes the design, description, and features of a multi-channel signal generator for non-invasive abdominal fetal electrocardiograms. Data from existing long-term clinical fECG studies were subjected to statistical processing and analysis. The results were then used to develop mathematical models describing the generation of fECG signals. The models were implemented into a signal generator based on Virtual Instrumentation by using a PC and the ELVIS II prototyping platform. The generator deployed a variety of informative parameters so the signals generated would match real signals from clinical practice as best as possible.

As a consequence of our findings, we plan to extend the potential of the preset patterns with additional physiological as well as pathological patterns conforming to clinical recommendations for CTG and STAN classifications. The existing prototype of the multi-channel non-invasive abdominal fetal electrocardiogram generator offers entirely new opportunities, which may find application in the diagnosis of developmental and congenital cardiac disorders in newborns. The majority of fetal congenital cardiac disorders are manifested in the morphology of the electric activity of the heart, recorded by fECG. A number of current studies indicate that the fECG signals contain much more information on congenital cardiac defects than what is provided by the conventional sonographic methods (echocardiograms). Experimental results have shown that high specificity and sensitivity can be attained in the non-invasive

fECG analysis starting from pregnancy Week 20. Some studies performed both on animals and humans indicate that congenital developmental defects (e.g. intrauterine fetal development retardation) affect the length of the waveforms, and the intervals or fECG segments.

The present paper reports work in progress and does not encompass all levels of sophistication that may affect the properties of the generated abdominal fECGs. It should be considered as a first step into the new and so far not very well understood area of trans-abdominal fetal monitoring. Additional extensive clinical research will be necessary to advance this field to new levels.

Acknowledgments

This work is partially supported by the Science and Research Fund 2014 of the Moravian-Silesian Region, Czech Republic and project SGS SP2015/181, VSB–Technical University of Ostrava, Czech Republic. A very special thanks belongs to M D Romana Gerychova, M D Jana Kadlecova, M D Veronika Tapalova, M D Kristyna Wagnerova, M D Kamil Frank and M D Lukas Hruban for their classification of the set of fECG records.

References

- Abdulhay E W, Oweis R J, Alhaddad A M, Sublaban F N, Radwan M A and Almasaeed H M 2014 Review article: non-invasive fetal heart rate monitoring techniques *Biomed. Sci. Eng.* **2** 53–67
- Agostinelli A, Grillo M, Biagini A, Giuliani C, Burattini L, Fioretti S, Di Nardo F, Giannubilo S R, Ciavattini A and Burattini L 2015 Noninvasive fetal electrocardiography: an overview of the signal electrophysiological meaning, recording procedures, and processing techniques *Ann. Noninvasive Electrocardiol.* **20** 303–13
- Behar J, Andreotti F, Zaunseder S, Li Q, Oster J and Clifford G D 2014a An ecg simulator for generating maternal-foetal activity mixtures on abdominal ecg recordings *Physiol. Meas.* **35** 1537–50
- Behar J, Johnson A, Clifford G and Oster J 2013 A comparison of single channel fetal ecg extraction methods *Ann. Biomed. Eng.* **42** 1340–53
- Campillo D, Guardarrama R, Gonzalez R, Rodriguez J and Jimenez D 2013 A real time ecg preprocessing system based on ads1298 *Computing in Cardiology Conf.* pp 947–50
- Chen H, Chauhan S, Ananth C, Vintzileos A and Abuhamad A 2011 Electronic fetal heart rate monitoring and its relationship to neonatal and infant mortality in the united states *Am. J. Obstet. Gynecol.* **204** 491.e1–10
- Chia E, Ho T, Rauff M and Yip W 2005 Cardiac time intervals of normal fetuses using noninvasive fetal electrocardiography *Prenatal Diagn.* **25** 546–52
- Chia L 2006 Assessment and quantification of foetal electrocardiography and heart rate variability of normal foetuses from early to late gestational periods *Ms Thesis* Department of Physiology, National University of Singapore
- Clifford G, Sameni R, Ward J, Robinson J and Wolfberg A 2011 Clinically accurate fetal ecg parameters acquired from maternal abdominal sensors *Am. J. Obstet. Gynecol.* **205** e1–47
- Clifford G, Silva I, Behar J and Moody G 2014 Non-invasive fetal ecg analysis *Physiol. Meas.* **35** 1521–36
- Collins R, Kenneth W and David A 2013 Adaptive signal processing methods for removing maternal interference noise from fetal electro-cardiograms *Ann. Res. J. Electr. Eng. Res. Exp. Undergrad.* **11** 89–102
- Estes S, Utsey K and Kalobwe E 2014 Mathematically modeling fetal electrocardiograms *J. Undergrad. Res. Univ. Tenn.* **5** 10
- Fayn J, Rubel P and Negahdaripour S 2007 Can the lessons learned from the assessment of automated electrocardiogram analysis in the common standards for quantitative electrocardiography study benefit measurement of delayed contrast-enhanced magnetic resonance images? *J. Electrocardiol.* **40** 246–50
- FIGO 2015 International federation of gynecology and obstetrics www.figo.org

- Freeman R, Garite T, Nageotte M and Miller L 2012 *Fetal Heart Rate Monitoring* 4th edn (Baltimore, MD: Williams and Wilkins)
- Gacek A and Pedrycz W 2012 *ECG Signal Processing, Classification and Interpretation* 1st edn (Berlin: Springer)
- Goldberger A, Amaral L, Glass L, Hausdorff J, Ivanov P, Mark R, Mietus J, Moody G, Peng C and Stanley H 2000 Physiobank, physiotoolkit, and physionet components of a new research resource for complex physiologic signal *Circulation* **101** 215–20
- Halawani S M and Kari S 2014 ECG simulation using fourier series: from personal computers to mobile devices **2** 1803–11
- Hasan M, Reaz B, Ibrahim M, Hussain M and Uddin J 2009 Detection and processing techniques of fecg signal for fetal monitoring *Biol. Proced. Online* **11** 263–95
- Jagannath D and Selvakumar A 2014 Issues and research on foetal electrocardiogram signal elicitation *Biomed. Signal Proc. Control* **10** 224–44
- Kahler C, Schleussner E, Grimm B, Schneider A, Schneider U, Nowak H and Seewald H 2002 Fetal magnetocardiography: development of the fetal cardiac time intervals *Prenatal Diagn.* **22** 408–14
- Khamene A and Negahdaripour S 2000 A new method for the extraction of fetal ecg from the composite abdominal signal *IEEE Trans. Biomed. Eng.* **47** 507–16
- Lyndon A, Ali L U, Barnes J D, Cypher R L and Gauthier D 2009 *Fetal Heart Monitoring Principles and Practices* 4th edn (USA: Kendall Hunt)
- Martinek R, Kelnar M, Koudelka P, Vanus J, Bilik P, Janku P, Nazeran H and Zidek J 2015a Enhanced processing and analysis of multi-channel non-invasive abdominal foetal ecg signals during labor and delivery *Electron. Lett.* **51** 1744–6
- Martinek R, Kelnar M, Vanus J, Koudelka P, Bilik P, Koziorek J and Zidek J 2015b Adaptive noise suppression in voice communication using a neuro-fuzzy inference system *IEEE 38th Int. Conf. on Telecommunications and Signal Processing* pp 382–6
- Martinek R, Kelnar M, Vojcinak P, Koudelka P, Vanus J, Bilik P, Janku P, Nazeran H and Zidek J 2015c Virtual simulator for the generation of patho-physiological foetal ecgs during the prenatal period *Electron. Lett.* **51** 1738–40
- Martinek R, Manas J, Bilik P and Zidek J 2013 Power quality improvement by shunt active performance filters emulated by artificial intelligence techniques *2nd Int. Conf. on Advances in Computer Science and Engineering (Los Angeles, USA)* pp 157–61
- Martinek R, Zidek J, Bilik P, Manas J, Koziorek J, Teng Z and Wen H 2013 The use of lms and rls adaptive algorithms for an adaptive control method of active power filter *Energy Power Eng.* **5** 1126–33
- Martinek R and Zidek J 2012a The real implementation of nlms channel equalizer into the system of software defined radio *Adv. Electr. Electron. Eng.* **10** 330–6
- Martinek R and Zidek J 2012b Refining the diagnostic quality of the abdominal fetal electrocardiogram using the techniques of artificial intelligence *Prz. Elektrotech.* **88** 155–60
- Martinek R and Zidek J 2012c A system for improving the diagnostic quality of fetal electrocardiogram *Prz. Elektrotech.* **88** 164–73
- Martinek R and Zidek J 2014 The real implementation of anfis channel equalizer on the system of software-defined radio *IETE J. Res.* **60** 183–93
- Martinek R 2014 The use of complex adaptive methods of signal processing for refining the diagnostic quality of the abdominal fetal electrocardiogram *PhD Thesis* Dissertation VSB: Technical University of Ostrava, Department of Cybernetics and Biomedical Engineering Czech Republic
- Matonia A, Jezewski J, Kupka T, Wrobel J and Horoba K 2005 Modelling of non-invasively recorded maternal and fetal electrocardiographic signals *Biocybern. Biomed. Eng.* **25** 27–39
- Ma Y, Xiao Y, Wei G and Sun J 2014 Fetal ecg extraction using adaptive functional link artificial neural network *IEEE Annual Summit and Conf. Asia-Pacific Signal and Information Processing Association* pp 1–4
- Morales D, Garcia A, Castillo E, Carvajal M, Parrilla L and Palma A 2013 An application of reconfigurable technologies for non-invasive fetal heart rate extraction *Med. Eng. Phys.* **35** 1005–14
- Nasiri M and Faez K 2012 Extracting fetal electrocardiogram signal using anfis trained by genetic algorithm *Int. Conf. on Biomedical Engineering* pp 197–202
- National Instruments 2014 Ni labview biomedical toolkit: tools for biomedical data acquisition and signal processing <http://sine.ni.com/nips/cds/view/plang/cs/nid/211023>
- National Instruments 2015 Ni data acquisition (DAQ) www.ni.com/data-acquisition
- Neilson J 2012 Fetal electrocardiogram (ECG) for fetal monitoring during labour *Cochrane Database of Systematic Review* **CD000116**

- Niknazar M, Rivet B and Jutten C 2013 Fetal ecg extraction by extended state kalman filtering based on single-channel recordings *IEEE Trans. Biomed. Eng.* **60** 1345–52
- Noventa Medical AB 2012 Stan s31 www.neoventa.com/products/stan
- Okamoto N and Ohsawa N 1988 CSE (common standards for quantitative electrocardiography) data testing in japan *J. Electrocardiol.* **21** S169–72 (Computerized Interpretation of the Electrocardiogram XIII www.sciencedirect.com/science/article/pii/0022073688900878)
- Rihana S, Terrien J, Germain G and Marque C 2009 Mathematical modeling of electrical activity of uterine muscle cells *Med. Biol. Eng. Comput.* **47** 665–75
- Sameni R, Clifford G D, Jutten C and Shamsollahi M B 2007 Multichannel ecg and noise modeling: application to maternal and fetal ecg signals *EURASIP J. Appl. Signal Proc.* **2007** 94
- Sameni R and Clifford G 2010 A review of fetal ECG signal processing, issues and promising directions *Open Pacing, Electrophysiol. Ther. J.* **3** 4–20
- Schats R, Jansen C and Wladimiroff J 1990 Embryonic heart activity: appearance and development in early human pregnancy *Int. J. Obstet. Gynaecol.* **97** 989–94
- Shuicai W, Shen Y, Zhou Z, Lin L, Zeng Y and Gao X 2013 Research of fetal ECG extraction using wavelet analysis and adaptive filtering *Comput. Biol. Med.* **43** 1622–27
- Singh R, Singh A and Kaur J 2016 Adaptive filter design for extraction of fetus ecg signal *Proc. of the Second Int. Conf. on Computer and Communication Technologies* (Berlin: Springer) pp 109–17
- Stancases 2015 Stancases: cases tagged fECG www.stancases.com/tags/fecg
- Steer P and Hvidman L 2014 Scientific and clinical evidence for the use of fetal ECG ST segment analysis (STAN) *Acta Obstet. Gynecol. Scand.* **93** 533–8
- Stinstra J et al 2002 Multicentre study of fetal cardiac time intervals using magnetocardiography *Int. J. Obstet. Gynecol.* **109** 1235–43
- Taralunga D D, Ungureanu G M, Gussi I, Strungaru R and Wolf W 2014 Fetal ecg extraction from abdominal signals: a review on suppression of fundamental power line interference component and its harmonics *Comput. Math. Methods Med.* **2014** 1–15
- Taylor M, Smith M, Thomas M, Green A, Cheng F, Oseku-Afful S, Wee L, Fisk N and Gardiner H 2006 Noninvasive fetal electrocardiography in singleton and multiple pregnancies *Int. J. Obstet. Gynecol.* **110** 668–78
- van Leeuwen P, Lange S, Hackmann J, Klein A, Hatzmann W and Gronemeyer D 2001 Assessment of intra-uterine growth retardation by fetal magnetocardiography *Biomag Proc. 12th Int. Conf. on Biomagnetism (Helsinki)* pp 603–6
- Vullings R, Mischi M, Oei S and Bergmans J 2013 Novel bayesian vectorcardiographic loop alignment for improved monitoring of ecg and fetal movement *IEEE Trans. Biomed. Eng.* **60** 1580–8
- Vullings R 2010 Non-invasive fetal electrocardiogram: analysis and interpretation *Doctoral Dissertation Technische Universteit Eindhoven Eindhoven*
- Wei Y C, Wei Y Y, Wey S T and Jang L S 2013 Design of a programmable ecg generator using a dynamical model *Applied Mechanics and Materials vol 311* (Switzerland: Trans Tech Publications) pp 485–90
- Willems J, van Bommel J, Degani R, Macfarlane P and Zywieta C 1990 Common standards for quantitative electrocardiography: goals and main results. CSE working party *Methods Inf. Med.* **29** 263–71
- Zeng Y, Liu S and Zhang J 2008 Extraction of fetal ecg signal via adaptive noise cancellation approach *IEEE The 2nd Int. Conf. on Bioinformatics and Biomedical Engineering* pp 2270–3